

3500/64M Dynamic Pressure Monitor

Datasheet

Bently Nevada Machinery Condition Monitoring

Description

The 3500/64M Dynamic Pressure Monitor is a single slot, four-channel monitor that accepts input from high temperature pressure transducers and uses this input to drive alarms. The monitor's one measured variable per channel is bandpass dynamic pressure.

You can use the 3500 Rack Configuration Software to configure the bandpass corner frequencies along with an additional notch filter. The monitor provides a recorder output for control system applications.

The primary purpose of the 3500/64M Dynamic Pressure Monitor is to provide the following:

- Machinery protection by continuously comparing monitored parameters against configured alarm setpoints to drive alarms
- Essential machine information for operations and maintenance personnel

Each channel, depending on configuration, conditions its input signal to generate various parameters called **measured variables**. You can configure **alert** and **danger** setpoints for each active measured variable.



Specifications

Inputs

Signal	Accepts from 1 to 4 pressure transducer signals
Input Impedance	
3 wire transducer	10 k Ω
2 wire	1.5 M Ω to 3.5 M Ω typical

Sensitivity

Dynamic pressure	100 mV/psi (1.45 mV/mBar)
------------------	---------------------------

Outputs

Front Panel LEDs

OK LED	Indicates when the 3500/64M Dynamic Pressure Monitor is operating properly.
TX/RX LED	Indicates when the 3500/64M is communicating with other modules in the 3500 rack.
Bypass LED	Indicates when the 3500/64M is in Bypass Mode.

Buffered Transducer

Outputs	The front of each monitor has one coaxial connector for each channel. Each connector is short-circuit protected. The Cascade Mode does not cascade the buffered transducer outputs.
Output Impedance	550 Ω

Transducer Supplies

3 wire	-24 Vdc
2 wire	3.3 mA current source @ 22 Vdc (nominal)
Recorder outputs	+4 to +20 mA Values are proportional to monitor full-scale. The monitor provides individual recorder values for each channel. Monitor operation is unaffected by short circuits on recorder outputs.
Voltage Compliance (current output)	0 to +12 Vdc range across load Load resistance is 0 to 600 Ω .
Resolution	0.3662 μ A per bit \pm 0.25% error at room temperature -0.66 to +0.70% error over temperature range

Update rate approximately 100 ms or less
--

Signal Conditioning

Dynamic Pressure - Direct Filter

Low mode	5 Hz to 4 KHz If no LP filter is chosen, the range extends to approximately 5.285 KHz
High mode	10 Hz to 14.75 KHz Fixed low pass

Low and high filtering modes are options for a channel pair. Channels 1 and 2 form a pair, and channels 3 and 4 are the other pair. You may select different band pass options on each channel of a channel pair. However, the channels within the pair must operate in the same filtering mode.

You can set up the signal processing so that the monitor feeds only the channel 1 input to all four channels. This feature is called Cascade Mode and is denoted as **1 >ALL** in the 3500 Rack Configuration Software.

In Cascade Mode, you can select filter mode options for a channel pair only. One transducer provides input to four channels for different filtering requirements. As a result, you can configure four separate bandpass filter options and four separate full-scale ranges with one transducer input.

The two modes of filtering provide different qualities of filtering.

Low Mode

Filter Quality

High pass	10-pole (200dB per decade, 60 dB per octave)
Low pass (LP)	10-pole (200dB per decade, 60 dB per octave)
Fixed low pass LP = none	-78 dB minimum attenuation in the stop band.

High Mode

Filter Quality	
High pass Low pass	6-pole (120 dB per decade, 36 dB per octave) -65 dB minimum attenuation in the stop band
Line rejection (notch) filter	The line rejection filter has two settings, 50 or 60 Hz. Filter response and center frequency selections are valid for both settings.
Filter quality response	-0.175 dB (98%) of Full Scale at Center Frequency of +2 Hz and above -0.175 dB (98%) of Full Scale at Center Frequency of -2 Hz and below -35 dB (1.8%) of Full Scale from -0.5 Hz of Center Frequency to +0.5 Hz of Center Frequency

Measured Variables

Dynamic pressure direct	The primary value for each channel
-------------------------	------------------------------------

Physical

Monitor Module (Main Board)	
Dimensions (Height x Width x Depth)	241.3 mm x 24.4 mm x 241.8 mm (9.50 in x 0.96 in x 9.52 in)
Weight	0.82 kg (1.8 lb)
I/O Modules (non-barrier)	
Dimensions (Height x Width x Depth)	241.3 mm x 24.4 mm x 99.1 mm (9.50 in x 0.96 in x 3.90 in)
Weight	0.20 kg (0.44 lb)
I/O Modules (with barrier)	
Dimensions (Height x Width x Depth)	241.3 mm x 24.4 mm x 163.1 mm (9.50 in x 0.96 in x 6.42 in)
Weight	0.46 kg (1.01 lb)

Alarms

Alarm Setpoints	Use the 3500 Rack Configuration Software to set alert and danger levels for the direct values measured by the monitor. Alarms are adjustable from 0 to 100% of full-scale for each measured value. However, when the full-scale range exceeds the range of the transducer, the range of the transducer will limit the setpoint.
Accuracy of alarm setpoints	Within 0.13% of the desired value

Alarm Time Delays

You can program alarm delays using the 3500 Rack Configuration Software from one to 60 seconds in one second intervals.

Alert	From one to 60 seconds in one second intervals
Danger	0.1 seconds or from one to 60 seconds in 0.1 second intervals

Compliance and Certifications

FCC

This device complies with part 15 of the FCC Rules. Operation is subject to the following two conditions:

- This device may not cause harmful interference.
- This device must accept any interference received, including interference that may cause undesired operation.

EMC

European Community Directive:

EMC Directive 2014/30/EU

Standards:

EN 61000-6-2 Immunity for
Industrial Environments

EN 61000-6-4 Emissions for
Industrial Environments

Electrical Safety

European Community Directive:

LV Directive 2014/35/EU

Standards:

EN 61010-1

RoHS

European Community Directive:

RoHS Directive 2011/65/EU

Maritime

ABS - Marine and Offshore Applications

DNV GL Rules for Classification – Ships,
Offshore Units, and High Speed and Light
Craft

Hazardous Area Approvals

 For the detailed listing of country and product specific approvals, refer to the *Approvals Quick Reference Guide* (108M1756) available from www.Bently.com.

CSA/NRTL/C

<p>When used with I/O module ordering options without internal barriers</p>	<p>Class I, Zone 2: AEx/Ex nA nC ic IIC T4 Gc; Class I, Zone 2: AEx/Ex ec nC ic IIC T4 Gc; Class I, Division 2, Groups A, B, C, and D; T4 @ Ta= -20°C to +65°C (-4°F to +149°F) When installed per drawing 149243 or 149244.</p>
<p>When used with I/O module ordering options with internal barriers</p>	<p>Class I, Zone 2: AEx/Ex nA nC ic [ia Ga] IIC T4 Gc; Class I, Zone 2: AEx/Ex ec nC ic [ia Ga] IIC T4 Gc; Class I, Division 2, Groups A, B, C, and D (W/ IS Output for Division 1) T4 @ Ta= -20°C to +65°C (-4°F to +149°F) When installed per drawing 138547.</p>

ATEX/IECEX

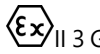
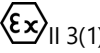
<p>When used with I/O module ordering options without internal barriers</p>	<p> Ex nA nC ic IIC T4 Gc; Ex ec nC ic IIC T4 Gc; T4 @ Ta= -20°C to +65°C (-4°F to +149°F) When installed per drawing 149243 or 149244.</p>
<p>When used with I/O module ordering options with internal barriers</p>	<p> Ex nA nC ic [ia Ga] IIC T4 Gc; Ex ec nC ic [ia Ga] IIC T4 Gc; T4 @ Ta= -20°C to +65°C (-4°F to +149°F) When installed per drawing 138547.</p>

Ordering Information



For the detailed listing of country and product specific approvals, refer to the *Approvals Quick Reference Guide* (108M1756) available from www.Bentley.com.

Dynamic Pressure Module 3500/64 - AA - BB

AA: I/O Module Type

01	I/O Module with Internal Termination
02	I/O Module with External Termination

BB: Agency Approval

00	None
01	CSA / NRTL / C (Class I, Division 2)
02	ATEX / IECEx / CSA (Class I, Zone 2)

External Termination (ET) Blocks

128015-09	Dynamic Pressure ET Block Terminal Strip connectors
125808-09	Dynamic Pressure ET Block Euro Style connectors
128710-01	Recorder Out ET Block Terminal Strip connectors
128702-01	Recorder Out ET Block Euro Style connectors

Cables

3500 Dynamic Pressure Signal to External Termination Block Cable 129525 - AAAA-BB

AA: I/O Cable Length

0005	5 feet (1.5 metres)
0007	7 feet (2.1 metres)
0010	10 feet (3.0 metres)
0025	25 feet (7.6 metres)
0050	50 feet (15.2 metres)
0100	100 feet (30.5 metres)

BB: Assembly Instructions

01	Not assembled
----	---------------

02	Assembled
----	-----------

3500 Recorder Output to External Termination Block Cable

129529-AAAA-BB

AA: I/O Cable Length

0005	5 feet (1.5 metres)
0007	7 feet (2.1 metres)
0010	10 feet (3.0 metres)
0025	25 feet (7.6 metres)
0050	50 feet (15.2 metres)
0100	100 feet (30.5 metres)

BB: Assembly Instructions

01	Not assembled
02	Assembled

Spares

176449-05	3500/64M Dynamic Pressure Monitor
140471-02	I/O Module Internal Termination
140482-02	I/O Module External Termination
143729-01	Cylinder Pressure I/O Internal Termination
04425545	Grounding wrist strap
04400037	IC Removal Tool
00580434	Connector Header Internal Termination 8 position, Green
00580436	Connector Header Internal Termination 6 position Green
00502133	Connector Header Internal Termination 12 position Blue

Graphs and Figures

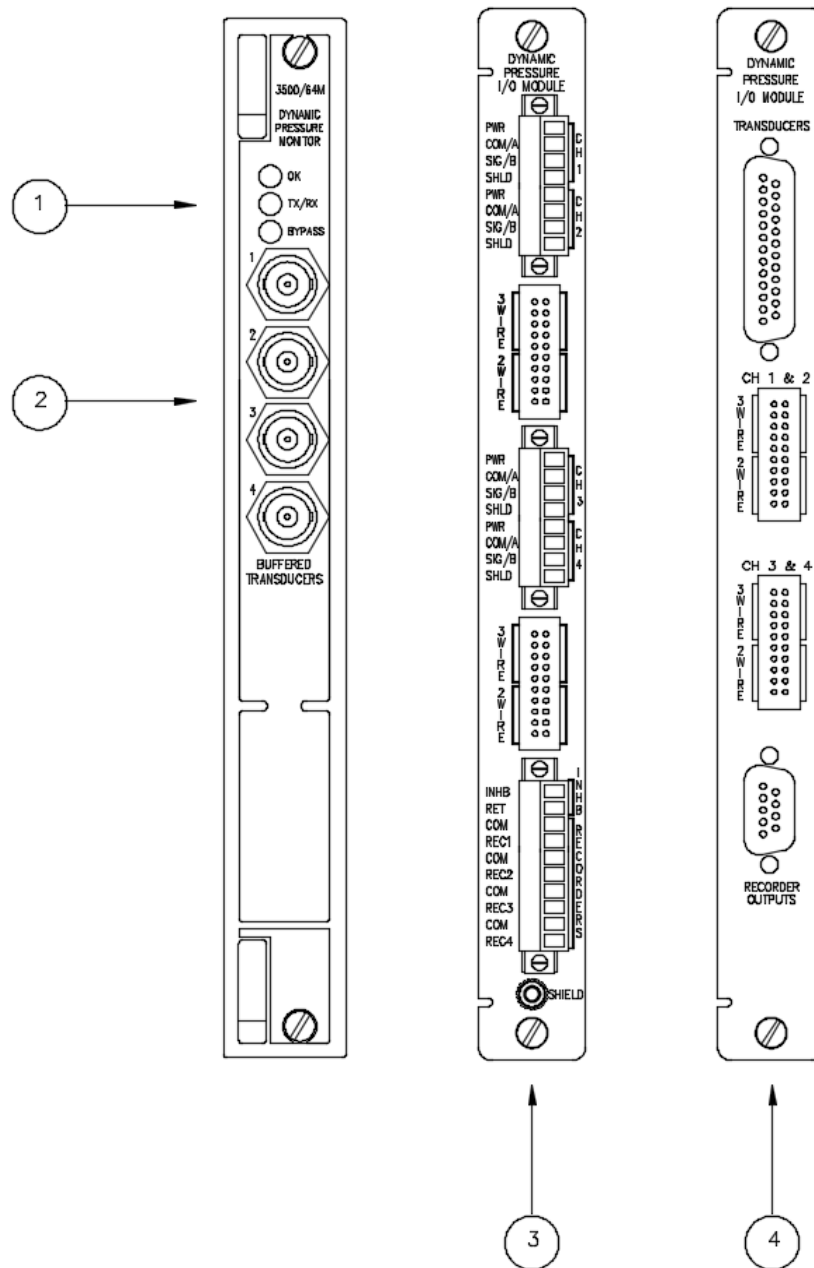

1. Status LEDs
2. Buffered Transducer Outputs
3. I/O Module with Internal Terminations
4. I/O Module with External Terminations

Figure 1: Front and Rear Views of 3500/64M Dynamic Pressure Monitor

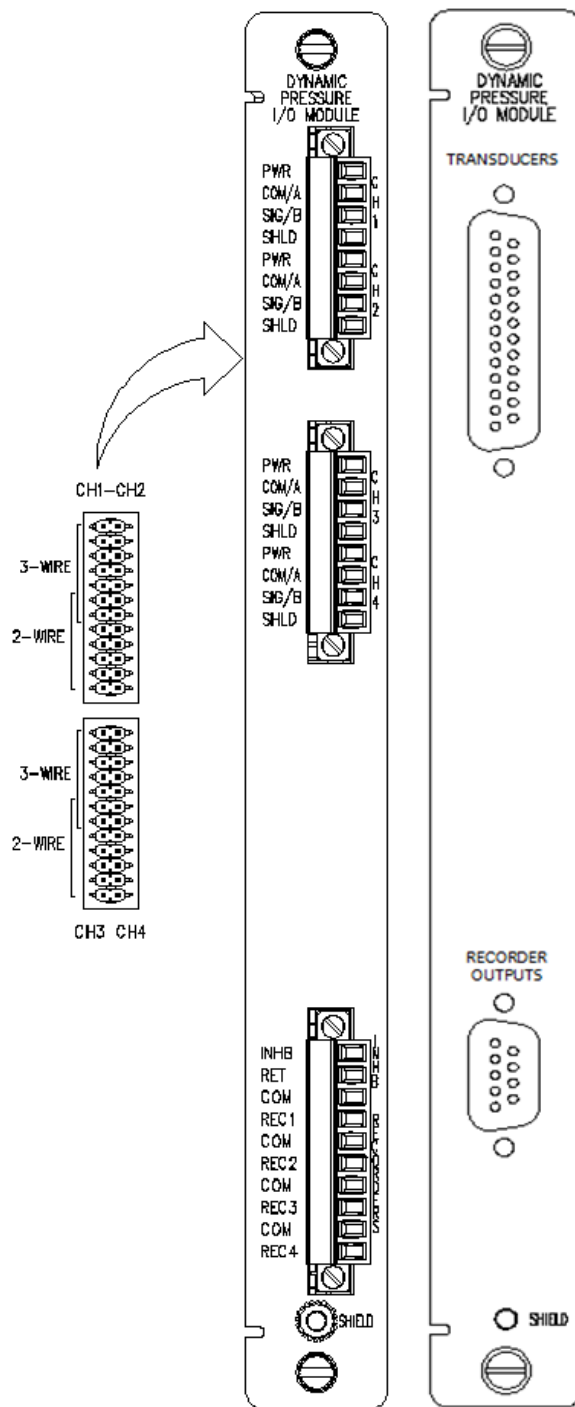

Figure 2: Side View of I/O Modules for 3500/64M

The I/O modules with internal or external terminations have the same jumpers.

Copyright 2019 Baker Hughes, a GE company, LLC ("BHGE") All rights reserved.

Bently Nevada and Orbit Logo are registered trademarks of BHGE in the United States and other countries. All product and company names are trademarks of their respective holders. Use of the trademarks does not imply any affiliation with or endorsement by the respective holders. This product may be covered by one or more patents, see Bently.com/legal for current status.

The information contained in this document is subject to change without prior notice.

1631 Bently Parkway South, Minden, Nevada USA 89423

Phone: 1.775.782.3611 Bently.com

