

General purpose, integral cable accelerometer

787F

SPECIFICATIONS

Sensitivity, $\pm 5\%$, 25°C		100 mV/g
Acceleration range		80 g peak
Amplitude nonlinearity		1%
Frequency response:	$\pm 10\%$	1 - 5,000 Hz
	± 3 dB	0.5 - 10,000 Hz
Resonance frequency		22 kHz
Transverse sensitivity, max		5% of axial
Temperature response:	-50°C	-5%
	+120°C	+5%
Power requirement:		
Voltage source		18 - 30 VDC
Current regulating diode		2 - 10 mA
Electrical noise, equiv. g, nominal:		
Broadband	2.5 Hz to 25 kHz	700 μ g
Spectral	10 Hz	10 μ g/ $\sqrt{\text{Hz}}$
	100 Hz	5 μ g/ $\sqrt{\text{Hz}}$
	1,000 Hz	5 μ g/ $\sqrt{\text{Hz}}$
Output impedance, max		100 Ω
Bias output voltage		12 VDC
Grounding		case grounded, internally shielded
Temperature range		-50° to +120°C
Vibration limit		500 g
Shock limit, min		5,000 g
Electromagnetic sensitivity, equiv. g, max		70 μ g/gauss
Sealing		hermetic
Base strain sensitivity, max		0.002 g/ μ strain
Hydrostatic pressure		100 psi
Sensing element design		PZT ceramic / shear
Weight		145 grams
Case material		316L stainless steel
Mounting		1/4-28 captive hex head screw w/ 0.046" diameter safety wire hole
Integral cabling		J9T2A, 16 ft., blunt cut

Accessories supplied: #80165-01 captive hex head screw; calibration data (level 2)



Key features

- Usable in submerged applications up to 30 ft.
- Manufactured in ISO 9001 facility

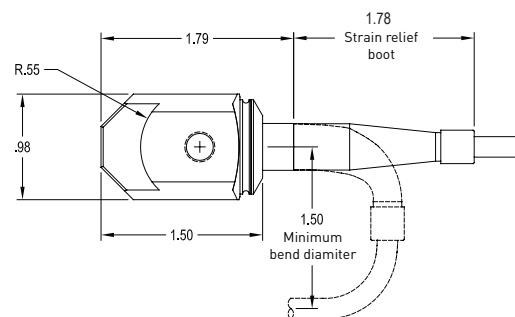
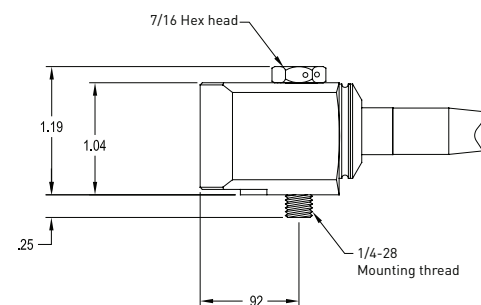

Connections	
Function	Cable conductor color
power/signal	white
common	black
case	shield



Note: Due to continuous process improvement, specifications are subject to change without notice. This document is cleared for public release.