

Autonics

Bar Graph Digital Indicator

KN-1000B SERIES

MANUAL



Thank you very much for selecting Autonics products.
For your safety, please read the following before using.

Caution for your safety

- ※Please keep these instructions and review them before using this unit.
- ※Please observe the cautions that follow;
 - Warning** Serious injury may result if instructions are not followed.
 - Caution** Product may be damaged, or injury may result if instructions are not followed.
- ※The following is an explanation of the symbols used in the operation manual.
 - Caution:** Injury or danger may occur under special conditions.

Warning

- In case of using this unit with machinery(Ex: nuclear power control, medical equipment, ship, vehicle, train, airplane, combustion apparatus, safety device, crime/disaster prevention equipment, etc) which may cause damages to human life or property, it is required to install fail-safe device. It may cause a fire, human injury or damage to property.
- Install this unit on a panel. It may cause electric shock.
- Do not connect, repair, or inspect this unit when power is ON. It may cause electric shock.
- Do not disassemble the case. Please contact us if it is required. It may cause electric shock or a fire.
- Wire properly after checking terminal numbers. It may cause a fire.

Caution

- This unit shall not be used outdoors. It might shorten the life cycle of the product or cause electric shock.
- Please observe the rated specifications. It might shorten the life cycle of the product or cause a fire.
- In cleaning this unit, do not use water or organic solvent. And use dry cloth. It may cause electric shock or a fire.
- Do not use this unit where there are flammable or explosive gas, humidity, direct ray of the sun, radiant heat, vibration and impact etc. It may cause a fire or explosion.
- Do not inflow dust or wire dregs into the unit. It may cause a fire or malfunction.
- Wire it properly after checking terminal numbers when connecting power cable and measuring input. It may cause a fire or explosion.

Ordering information

KN-1000B	Size	B	DIN W36×H144 mm
	Power supply	0	100-240 VAC 50 to 60 Hz
		1	24 VDC
	Option output	0	No option
		1	Transmission output (4-20 mA)
		4	RS485 communication output
	Alarm output	0	No alarm output
		2	2EA alarm output
		4	4EA alarm output
	Item	KN-1	Bar Graph Indicator

Part descriptions

- Display part(red)
 - Run mode: Displays current measurement value.
 - Parameter set mode: Displays parameter and SV.
- Unit sticker part (unit sticker is an accessory)
- Alarm output indicator: Turns ON when the alarm is ON.
- [M] key: Used to enter parameter set mode, move to parameters, save SV and return to RUN mode.
- [←], [→], [↔] key: Used to enter and change parameter SV.
- D.IN3: Press the [←] and [→] keys for 3 sec. at the same time, it operates the set function (alarm clear, display hold, zero-point adjustment) at di-t at program mode.
- Bar Graph(with 101 bar LEDs, green)
 - Displays measured value as bar graph.
- Space for recognizing device by user

※ The above specifications are subject to change without notice.

Connections

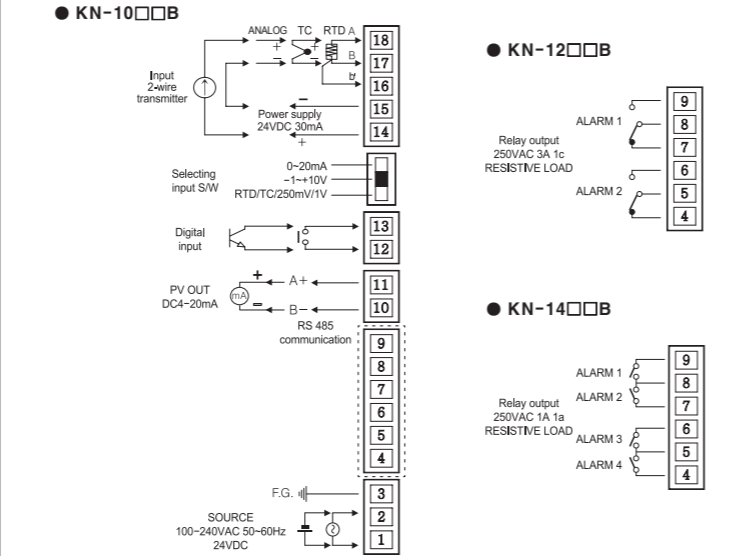

Dimensions

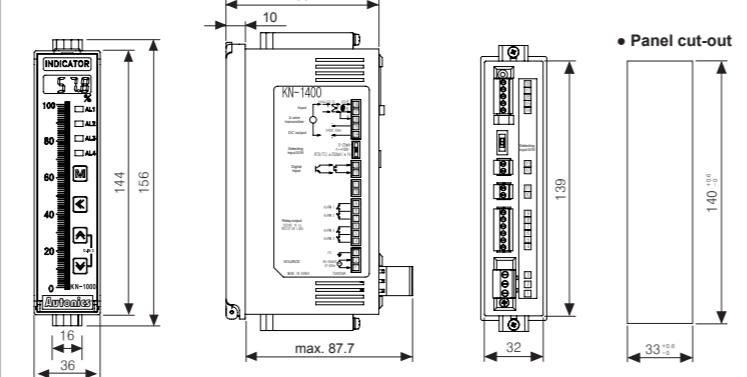

Input type and range

Input type selection switch

- 0-20 mA: Select it for 0(4)-20 mA input
- 1-10 V: Select it for -1 V-10 V input
- RTD/TC/mV±1V: Select it for RTD, TC temperature sensor or ±1V, mV input

This unit is multi input product. Select the proper input with the input type selection switch and select this input type in I-n-P in program mode. The setting of input type selection switch and the input type I-n-P parameter should be same and it can display the proper measurement value. Factory default is 0-20 mA.

Input type	Parameter	Input range(°C)	Input range(°F)	
K(CA)	tCk1	-200 to 1350	-328 to 2462	
K(CA)	tCk2	-199.9 to 999.9	-328 to 1832	
J(IC)	tC-J	-199.9 to 800.0	-328 to 1472	
E(CR)	tC-E	-199.9 to 800.0	-328 to 1472	
T(CC)	tC-t	-199.9 to 400.0	-199.9 to 752.0	
B(PR)*	tC-b	100 to 1800	212 to 3272	
R(PR)	tC-r	0 to 1750	32 to 3182	
S(PR)*	tC-5	0 to 1750	32 to 3182	
N(NN)*	tC-n	-200 to 1300	-328 to 2372	
C(W5)*	tC-c	0 to 2300	32 to 4172	
L(IC)*	tC-l	-199.9 to 900.0	-328 to 1652	
U(CC)*	tC-u	-199.9 to 400.0	-199.9 to 752.0	
Platine II*	tC-P	0 to 1390	32 to 2534	
RTD	Cu500*	tU50	-199.9 to 200.0	-199.9 to 392.0
	Cu1000*	tU10	-199.9 to 200.0	-199.9 to 392.0
	JPt100Ω	JPt.1	-199.9 to 600.0	-328 to 1112
	DPT50Ω	dPt.5	-199.9 to 600.0	-328 to 1112
	DPT100Ω	dPt.1	-199.9 to 850.0	-328 to 1530
Analog	0.00 - 20.00 mA	RnR1	-1999 to 9999	
	4.00 - 20.00 mA	RnR2	-1999 to 9999	
	-50.0 - 50.0 mV	Rnu1	-1999 to 9999	
	-199.9 - 200.0 mV	Rnu2	-1999 to 9999	
-1.000 - 1.000 V	R-u1	-1999 to 9999		
-1.00 - 10.00 V	R-u2	-1999 to 9999		

(Display range is variable according to decimal point position.)

※Above input types which have the * mark are not displayed. To display the above input types, supply the power with pressing the [M] key.

Specification

Series	KN-1000B
Power supply	AC voltage 100-240 VAC 50 to 60 Hz DC voltage 24 VDC
Allowable voltage range	90 to 110% of rated voltage
Power consumption	AC voltage Max. 6 VA DC voltage Max. 4 W
Display method	4digit: 7Segment LED Display (red), Bar LED: 101EA (green)
Input type	RTD JPt100Ω, DPT100Ω, DPT50Ω, Cu500, Cu1000 (5 types) K, J, E, T, R, B, S, N, C (W5), L, U, PLII (12 types) Analog ● Voltage: ±1.000 V, ±50.00 mV, -199.9-200.0 mV, -1.00 V-10.00 V (4 types) ● Current: 4.00-20.00 mA, 0.00-20.00 mA (2 types) ● Contact input: Max. 2 kΩ in ON, Max. 90 kΩ in OFF ● Non-contact input: Residual voltage max. 1.0 V in ON, Leakage current max. 0.03 mA in OFF ● Outflow current: Approx. 0.2mA
Digital input	
Sub output	Alarm output 2-point: Relay contact capacity 250 VAC 3 A 1c, 4-point: Relay contact capacity 250 VAC 1 A 1a Trans. output ISOLATED DC 4-20 mA(PV transmission) load resistance max. 600 Ω (accuracy: ±0.2%F.S., resolution: 8000) Com. output RS485 (Modbus RTU)
Display accuracy	±0.2% F.S. ±1digit (25 °C±5 °C) ±0.3% F.S. ±1digit (-10 °C to 20 °C, 30 °C to 50 °C) In case of thermocouple and below -100 °C input, [±0.4%F.S.]±1digit ※TC-T, TC-U is min. ±2.0 °C
Setting method	Set by front keys, or RS485 communication
Alarm output hysteresis	Set ON/OFF interval (1 to 999 digit)
Sampling cycle	Analog input: 100 ms, Temperature sensor input: 250 ms
Dielectric voltage	2000 VAC 50/60 Hz for 1 min. (between input terminal and power terminal)
Vibration	0.75 mm amplitude at frequency of 5 to 55 Hz (for 1 min.) in each of X, Y, Z directions for 2 hours
Relay life cycle	2-point Mechanical: Min. 10,000,000, Electrical: Min. 100,000 (250 VAC 3 A resistance load) 4-point Mechanical: Min. 20,000,000, Electrical: Min. 500,000 (250 VAC 1 A resistance load)
Insulation resistance	Min. 100 MΩ (at 500VDC megger)
Noise resistance	Square shaped noise by noise simulator (pulse width 1 μs) ±2 kV
Memory retention	Approx. 10 years (non-volatile semiconductor memory type)
Environ-ment	Ambient temperature -10 to 50 °C, storage: -20 to 60 °C Ambient humidity 35 to 85%RH, storage: 35 to 85%RH
Approval	CE
Unit weight	Approx. 200 g

※Environment resistance is rated at no freezing or condensation.

Factory default

Parameter	Default	Parameter	Default	Parameter	Default
AL1	0999	AL3	000.1	HPEL	----
AL2	0999	AL4	000.1	LPEL	----

Program mode

Parameter	Default	Parameter	Default	Parameter	Default	Parameter	Default
I-n-P	RnR1	I-n-b	0000	AL-1	AL1A	di-t	Hold
Unit	°C	L-b5	0000	AL-2	AL1A	di-e	Hold
L-rG	0000	H-b5	1000	AL-3	AL2A	bURN	oFF
H-rG	2000	bAR	FbAR	AL-4	AL2A	Addr	01
dP	00	LoUt	0000	A-HY	001	bAUD	9600
L-5C	0000	HoUt	1000	I-n5F	Lin	LoCk	oFF
H-5C	1000	E~10	5P	nAUF	04		

Monitoring mode

※1. [M]: Press any key among the [←], [→], [↔].

※2. [←], [→], [↔]: Moves digits / [↔]: Changes SV.

※3. Press the [M] key after checking/changing SV in each parameter. The value flashes twice and is saved. It moves to next parameter.

※After entering setting group, press the [M] key for 3 sec. or there is no additional key operation in 30 sec., it returns to RUN mode.

※: This parameter may or may not appear, depending on the other parameter set or model type.

※Displayed only for alarm output models.

Set each alarm value: [AL-1 to AL-4] in program mode.

• Set range: Temp. sensor input → within temperature range
Analog input → L-5C to H-5C

※When alarm operation [AL-1 to AL-4] in program mode is no alarm [AL-1] or sensor break alarm [5bA], these parameters are not displayed.

※For 2EA alarm output model(KN-1200B), AL3, AL4 are not displayed.

Displays high/low peak value.

※High/Low peak value is available only to check and initialize it. (Refer to 'High/Low peak monitoring' for initialization.)

※Initial high/low peak is saved after 2 sec. from supplying the power.

Program mode

※1. [M]: Press any key among the [←], [→], [↔].

※2. [←], [→], [↔]: Moves digits / [↔]: Changes SV.

※3. Press the [M] key after checking/changing SV in each parameter. The value flashes twice and is saved. It moves to next parameter.

※After entering setting group, press the [M] key for 3 sec. or there is no additional key operation in 30 sec., it returns to RUN mode.

※: This parameter may or may not appear, depending on the other parameter set or model type.

※Displayed only when selecting temperature sensor input type.

※Displayed only when selecting analog input type.

Set input type. (Refer to [M] Input type and range.)

Temperature unit: Unit, °C, °F

Low limit input value: L-rG, 0400

High limit input value: H-rG, 2000

Decimal point: dP, 00

Low limit scale value: L-5C, 0000

High limit scale value: H-5C, 1000

Input correction: I-n-b, 0000

Bar graph low limit scale value: L-b5, 0000

Bar graph high limit scale value: H-b5, 0000

Bar graph display method: bAR, FbAR, CbAR

4 mA output scale value: LoUt, 0000

20 mA output scale value: HoUt, 1000

Input and trans. output extension: E~10, 5P

AL1 mode: AL-1, AL1A

AL2 mode: AL-2, AL1A

AL3 mode: AL-3, AL2A

AL4 mode: AL-4, AL2A

AL output hysteresis: A-HY, 001

Input special function: I-n5F, Lin, root, 59AR, tUF

Digital filter: nAUF, 04

Digital input terminal: di-t, Hold

Digital input key: di-e, Hold

Sensor break alarm output: bURN, on, oFF

Com. address: Addr, 01

Com. speed: bAUD, 9600, 19200, 1200, 2400, 4800

Lock: LoCk, oFF, LoC1, LoC2

Functions

Alarm [AL-1, AL-2, AL-3, AL-4]

This product has 2 or 4 alarms to operate individually when the value is too high or low. Alarm function is set by the combination of alarm operation and alarm option.

To clear alarm, use digital input function (setting $d1-t$, $d1-t$ as $ALrE$) or turn the power OFF and ON.

※For the model (KN-10□□B) without alarm output, these parameters are not displayed.

Alarm operation

Mode	Name	Operation	Descriptions
$AL0$	—	—	No alarm operation
$AL1$	High limit alarm	OFF → ON High limit alarm value: 800°C PV	$PV \geq$ alarm temperature, alarm is ON
$AL2$	Low limit alarm	ON → OFF Low limit alarm value: 200°C PV	$PV \leq$ alarm temperature, alarm is ON
$5bAL$	Sensor break alarm	—	It will be ON when it detects sensor disconnection. Sensor break alarm does not have alarm option.

※ H : Alarm output hysteresis

Alarm option

Option	Name	Descriptions
$AL1A$	Standard alarm	If it is an alarm condition, alarm output is ON. Unless an alarm condition, alarm output is OFF.
$AL1b$	Alarm latch	If it is an alarm condition, alarm output is ON. Before clearing the alarm, an ON condition is latched. (Holding the alarm output)
$AL1c$	Standby sequence	First alarm condition is ignored. From the second alarm condition, standard alarm operates. When power is ON and it is an alarm condition, it is ignored. From the second alarm condition, standard alarm operates.
$AL1d$	Alarm latch and standby sequence	If it is an alarm condition, it operates both alarm latch and standby sequence. When power is ON and it is an alarm condition, it is ignored. From the second alarm condition, alarm latch operates.

Alarm output hysteresis [Program mode: A-HY]

Set the interval of ON/OFF alarm output.

The set hysteresis is applied to AL1 to AL4 and it is as below.

※Ex) A-HY: 4, high limit alarm value: 800, low limit alarm value: 200

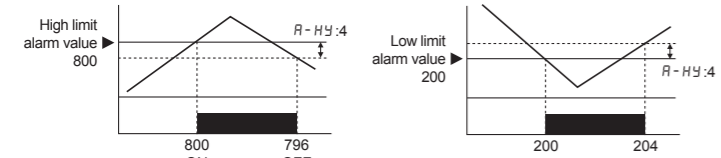

High/Low peak monitoring [Monitoring mode: HPEL, LPEL]

This function is to save high/low peak to check the invisible abnormal condition of system at [HPEL] or [LPEL] in monitoring mode.

When the high/low peak is out of the temperature range, it displays HHHH or LLLL. To initialize high/low peak, press the \square , \square keys at the same time for 3 sec. at [HPEL] or [LPEL]. In this case, peak value is the present input value.

Error

Display	Descriptions	Troubleshooting
LLLL	Flashes when measured sensor input is lower than the temperature range.	When input is moved within the temperature range, it is cleared.
HHHH	Flashes when measured sensor input is higher than the temperature range.	When input is moved within the temperature range, it is cleared.
bUr	Flashes when the sensor is break or not connected.	Check temperature sensor connection.
Err	Flashes when there is error to SV	Check set conditions and re-set it.

Parameter initialization

To initialize all parameter as factory default, supply the power to the product with pressing the \square and \square keys at the same time and it enters initialization parameter.

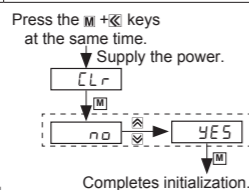

Decimal point [Program mode: dP]

It is able to change decimal point position for high/low limit scale value. It changes decimal point position of display value.

Transmission output scale [Program mode: LOUT, HOUT]

For 4-20 mA current output, this function is to set the display value for 4 mA [$LOUT$] and the display value for 20 mA [$HOUT$].

The interval between $LOUT$ and $HOUT$ is 10% F.S. If it is below 10%, it is fixed as 10% of SV.

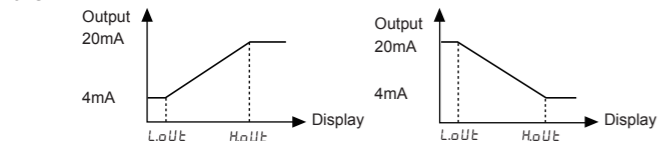

User input range [Program mode: L-rG, H-rG]

When selecting analog input, you can set the input range for your purpose. Set low limit input value [$L-rG$] and high limit input value [$H-rG$] to limit the input range.

※Set conditions : Low limit input value [$L-rG$] +20%F.S. < High limit input value [$H-rG$]

Display scale [Program mode: L-5C, H-5C]

For analog input, this function is to set (-1999 to 9999) for particular high/low limit value in order to display high/low limit value of measurement input. If measurement inputs are 'a' and 'b' and particular values are 'A' and 'B', it will display a=A, b=B as below graphs.

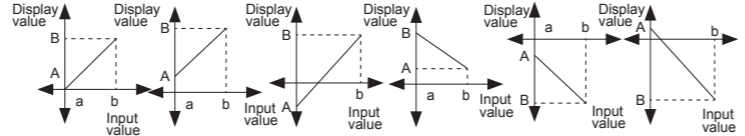

Display scale function is able to change display value for max./min. measured input by setting high limit scale [$H-5C$] and low limit scale [$L-5C$] in program mode.

※Ex) Set high/low scale value (input range is 0 to 10V)

- $L-5C = 0.00$
- $H-5C = 5.00, 10.00, 15.00, -10.00$
- $L-5C = 10.00$
- $H-5C = -10.00$
- $L-5C = -5.00$
- $H-5C = 5.00$

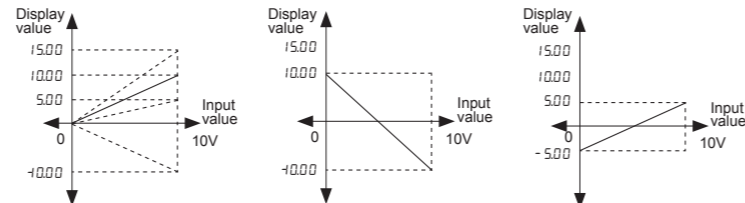

※When changing input type, high/low scale is changed as factory default.

Input correction [Program mode: I-nb]

This function is to correct the error occurring from a thermocouple, a RTD or analog input out of allowable error range of this unit.

This is also available to correct error when a sensor cannot contact the subject position by calculating the error temperature.

Variable temperature sensors have accuracy level. Because high accuracy type is expensive, standard thermocouples are generally used.

In this case, temperature sensor may occur error. By executing this function, you can get more accurate temperature.

When executing input correction function, you should measure the error from a sensor accurately. If the measured error is not correct, error may be greater.

(If $I-nb = tUF$, $I-nb$ as atmospheric pressure input value not as input correction function. Refer to Two unit function.)

Ex) When measured temperature is 4 °C and actual temperature is 0 °C. Set $I-nb$ as -4, and display value is 0 °C.

Bar graph scale [Program mode: L-b5, H-b5]

This is to set display range for bar graph. Display range is as below.

Parameter	Input	Display range
$L-b5$	Temp. sensor input	Input range $\leq L-b5 \leq (H-b5-1)$
	Analog input	$L-5C \leq L-b5 \leq (H-5C-1)$
$H-b5$	Temp. sensor input	$(L-b5+1) \leq H-b5 \leq$ Input range (high limit)
	Analog input	$(L-5C+1) \leq H-b5 \leq H-5C$

※Relation among input range, user input range, display scale, bar graph scale, and transmission scale.

The below figure is the example for 4 to 20 mA.

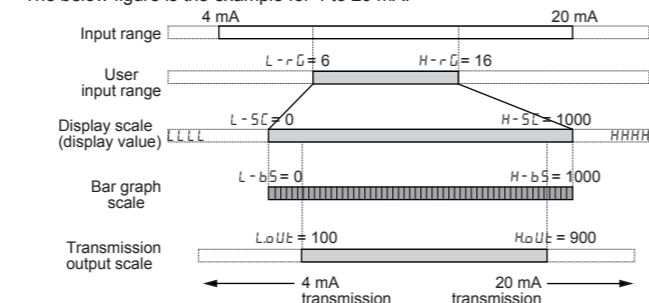

Bar graph display method [Program mode: bAr]

There are two methods for bar graph display; full bar and center bar.

Full bar [$F.bAr$] displays input from the bottom, and center bar method [$C.bAr$] displays input from '0' as below figures.

※Ex) When $L-b5 = -100$, $H-b5 = 100$, $PV = -50$,

Full Bar : F.bAr

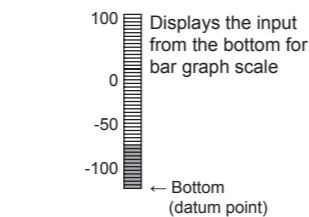

Center Bar : C.bAr

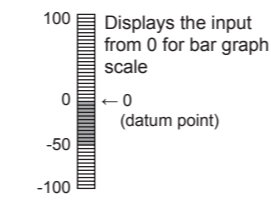

Input and transmission output extension [Program mode: E4J]

This is to extend analog input and 4 to 20mA transmission output to 5% or 10% range.

Mode	Operation
OP	Outputs 4 to 20 mA within analog input range.
$5P$	Outputs 3.2 to 20.8 mA for 5% out of the analog input range.
$10P$	Outputs 2.4 to 21.6 mA for 10% out of the analog input range.

※This parameter is displayed only for transmission output (4-20 mA) model. But it is not displayed when selecting temperature sensor input.

※The below of 0 mA, 0 V cannot be extended.

※±1 V, 10 V inputs are only available for 5% extension.

Alarm display in bar graph

When setting or occurring the alarm, it displays the status by the bar graph. You can check the alarm status. When setting alarm value, the bar LED for this alarm value turns ON. When alarm occurs, the bar LED for this alarm value flashes.

① When setting alarm value,

The bar LED for alarm SV flashes. When alarm set is complete, the bar LED for this alarm value turns ON.

② RUN mode

• All set alarm values are displays in RUN mode.

• When it is alarm value, the bar LED for this alarm value flashes.

If alarm set value is out of bar graph scale when setting the value or in RUN mode, this value does not display in bar graph.

When setting alarm value in monitoring mode, When all alarms are OFF,

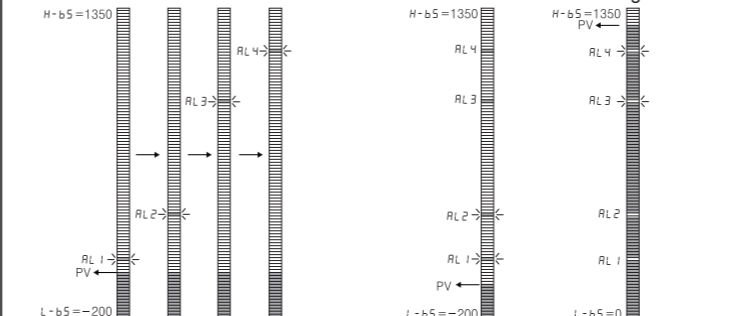

※The bar LED for the alarm value flashes.

Input special function [Program mode: I-n5F]

When selecting analog input, this function is to display the calculated actual value by square, root ($\sqrt{\quad}$), or two unit function (TUF) as display value.

Parameter	Functions	Graph	Applications
LIn	Outputs as input value	$Y = AX + B$	Standard characteristics. Input for linearity.
$r\sqrt{\quad}$	Outputs the rooted ($\sqrt{\quad}$) input value	$Y = A(\sqrt{X}) + B$ ($X \geq 0$) $Y = 0(X < 0)$	Used for measuring flows by pressure signal.
$59Ar$	Outputs the squared input value	$Y = A(X)^2 + B$ ($X > 0$) $Y = -A(X)^2 + B$ ($X < 0$)	Used for outputting differential pressure by flow signal.
tUF	Refer to 'Two unit function'		

※Display value and mA output value for $59Ar$:

$$\text{Display value} = \left(\frac{\text{Input value} - L-rG}{H-rG - L-rG} \right) \times (H-5C - L-5C) + L-5C$$

※Display value and mA output value for $r\sqrt{\quad}$:

$$\text{Display value} = \left(\sqrt{\frac{\text{Input value} - L-rG}{H-rG - L-rG}} \right) \times (H-5C - L-5C) + L-5C$$

Two Unit Function [Program mode: tUF]

When connecting a pressure sensor, compound pressure which is below atmospheric pressure (0) is for vacuum as mmHg and which is atmospheric pressure or over it is for positive pressure as kg/cm^2 .

Atmospheric pressure is 0 kg/cm^2 . When this unit does not display 0 kg/cm^2 , you can correct zero-point adjustment function.

When using two unit function, $L-5C$ is fixed as -760.

$L-5C$ is displayed but you cannot set this. You can set $H-5C$ within 0 to 9999 range.

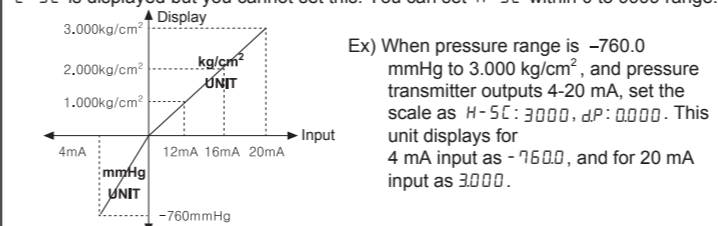

Ex) When pressure range is -760.0 mmHg to 3.000 kg/cm^2 , and pressure transmitter outputs 4-20 mA, set the scale as $H-5C : 3000$, $dP : 0.000$. This unit displays for 4 mA input as -760.0, and for 20 mA input as 3.000.

Digital filter [Program mode: nArF]

Moving average digital filter is able to stably display and output the noise from input line and irregular signals as software.

• Filter set range : 01 to 16

(When setting as 01, digital filter function does not run.)

※ Display cycle is same when executing moving average digital filter.

Burn Out [Program mode: bUr]

When disconnecting input sensor, you can set the status of transmission output.

• When setting bUr as on, 4-20 mA transmission output is fixed as 20 mA.

• When setting bUr as off, 4-20 mA transmission output is fixed as 4 mA.

※It is available only for temperature sensor input and 4-20 mA transmission output.

Digital input [Program mode: dI-t, dI-t]

By digital input terminal [$d1-t$] (no. 12, 13 terminals) or digital input key [$d1-t$] (D.IN3 : \square for 3 sec.), one of three functions executes as the below table.

Function	Operation
$ALrE$ Alarm clear	When alarm is ON in RUN mode, it clears alarm forcibly. (It applies only for alarm latch, alarm latch and standby sequence options.) Alarm clear operates only when the value is out of the alarm value range. After clearing alarm, alarm operates its option normally. ※ For the model without alarm output (KN-10□□B), this parameter is not displayed.
$HoLd$ Display HOLD	Temporarily indicated value is stopped in order to check indicated value in unstable input.
$ZEro$ Zero-point adjustment	Set preset display value as 0. This function is related with input correction [$I-nb$]. When executing zero adjustment function in display value as 4, input correction value [$I-nb$] is set as -4 automatically.

Lock [Program mode: LoL]

It limits to check parameter set value and to change it.

Program mode	oFF	LoL	LoL2
Monitoring mode	●	○	○

• : Enable to check/set, ○ : Enable to check, disable to set, ○ : Disable to check

※ In $LoL2$, only LoL parameter displays in program mode.

Communications

Communication manual

Refer to communication manual for RS485 communication.

Visit our web site (www.autonics.com) to download communication manual and software [Integrated device management program: DAQMaster].

Software [Integrated device management program: DAQMaster]

Integrated device management program, DAQMaster, is able to set and monitor parameters. It is available only for RS485 communication model.

Item	Minimum requirements
System	IBM PC compatible computer with Intel Pentium III or above
Operating system	Microsoft Windows 98/NT/XP/Vista/7
Memory	256MB or more
Hard disk	More than 1GB of free hard disk space
VGA	1024x768 or higher resolution display
Others	RS-232 serial port(9-pin), USB port

Communication specifications

Item	Specifications	Item	Specifications
Com. method	RS485 2-wire half duplex	Protocol	MODBUS 1.1 RTU
Com. speed (BPS)	9600, 4800, 2400, 1200	Parity	None
Converter	Converter built in RS232	Stop Bit	1Bit
Max. connections	32 units	Data length	8Bit
Com. distance	Max. 1200m (within 700m recommended)		

Caution for using

- For connecting the power, use a crimp terminal (M3.5, min. 7.2 mm).
 - The connection of this unit should be separated from the power line and high voltage line in order to prevent inductive noise.
 - Install a power switch or a circuit breaker to supply or cut off the power.
 - Switch or circuit breaker should be installed nearby users for convenient control.
 - Do not use this unit near the high frequency instruments (high frequency welding machine & sewing machine, large capacity SCR controller).
 - When supplying input, if HHHH or LLLL is displayed, measured input may have problem. Turn off the power and check the line.
 - Installation environment
 - It shall be used indoor.
 - Pollution Degree 2
 - Altitude max. 2,000 m
 - Installation category II
- ※It may cause malfunction if above instructions are not followed.

Major products

- Photoelectric sensors
- Fiber optic sensors
- Door sensors
- Door side sensors
- Area sensors
- Proximity sensors
- Pressure sensors
- Rotary encoders
- Connectors/Sockets
- Switching mode power supplies
- Control switches/Lamps/Buzzers
- I/O Terminal Blocks & Cables
- Stepper motors/drivers/motion controllers
- Graphic/Logic panels
- Field network devices
- Laser marking system (Fiber, CO₂, Nd:YAG)
- Laser welding/soldering system
- Temperature controllers
- Temperature/Humidity transducers
- SSR/Power controllers
- Counters
- Timers
- Panel meters
- Tachometer/Pulse(Rate)meters
- Display units
- Sensor controllers
- Recorders
- Indicators
- Converters
- Controllers
- Thyristor units
- Pressure transmitters
- Temperature transmitters

Autonics Corporation
<http://www.autonics.com>

Satisfiable Partner For Factory Automation

HEAD QUARTERS:
116, Unbigongdan-gil, Yangsan-si, Gyeongsangnam-do, Korea
OVERSEAS SALES:
#402-404, Buecheon Techno Park, 655, Pyeongcheon-ro, Wonmi-gu, Buecheon, Gyeonggi-do, Korea
TEL: 82-32-610-2730 / FAX: 82-32-329-0728
E-mail: sales@autonics.com

The proposal of a product improvement and development: product@autonics.com