



Füllstand



Druck



Durchfluss



Temperatur



Flüssigkeits-
analyse



Registrierung



Systeme
Komponenten



Services



Solutions

Technical Information

Liquicap T FMI21

Capacitive level measurement

Two-rod probe for continuous measurement in liquids

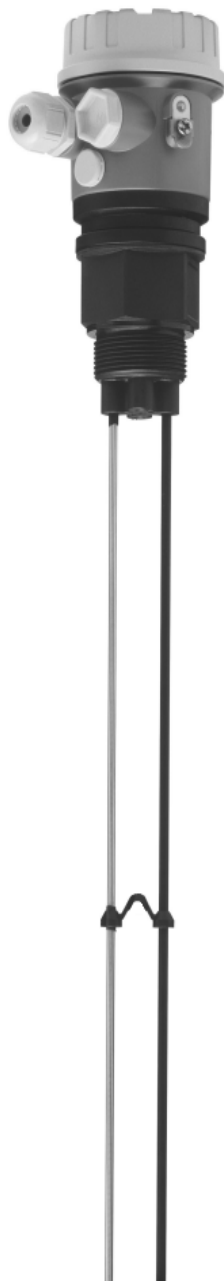

Application

The Liquicap T sensor is used in conductive liquids (as of 30 $\mu\text{S}/\text{cm}$) for continuous level measurement and is preconfigured from factory 0 %...100 % to probe length ordered.

As of a conductivity of 30 $\mu\text{S}/\text{cm}$, the measurement is independent of the dc-value (dielectric constant) of the liquid. It can also be deployed in Ex area, Zone 2.

The Liquicap T is particularly suited to the following applications:

- Small measuring ranges (as of 150 mm)
- Cistern measurements
- Aggressive liquids (many acids and alkalis)
- Independent of the tank material (plastic, stainless steel or concrete) or the tank shape

Used in conjunction with the Fieldgate FXA320 (remote measured value interrogation using Internet technology), Liquicap T is an ideal solution for inventorying material and optimising logistics (inventory control).

Your benefits

- Safe function regardless of tank geometry thanks to probe design
- No calibration necessary (preconfigured from factory 0 %...100 % to probe length ordered)
- High quality, non-corrosive materials (carbon fibre, stainless steel) for use in aggressive liquids and liquids which present a hazard to water (WHG-approved (German Water Resources Law))
- No moving parts in tank - long operating life - dependable function without wear
- Cost-effective solution for continuous measurement of levels in conductive liquids
- Optimised storage by simply shortening the probe rods on site (probe shortening set)

Table of contents

Function and system design	3	Fitted electrodes	11
Measuring principle	3	Human interface	12
Measuring system	3	Operating elements	12
Operating medium	4	Display elements	12
Applications	4	Certificates and approvals	13
Input	5	CE mark	13
Measured variable	5	Overfill protection	13
Measuring range	5	Other standards and guidelines	13
Input signal	5	Ex approval	13
Output	5	Type of protection	13
Electronic insert FEI20 (4...20 mA)	5	Ordering information	14
Power supply	5	Liquicap T FMI21	14
Electrical connection (wiring diagram)	5	Accessories	14
Transmitter power supply units from Endress+Hauser	6	Liquicap T	14
Supply voltage (FEI20)	6	Spare parts	14
Power consumption	6	Documentation	15
Current consumption	6	Technical Information	15
Cable entries	6	Operating Instructions	15
Cable specifications	6	Certificates	15
Performance characteristics with installed electronic insert	6		
Reference operating conditions	6		
Maximum measured error	6		
Repeatability	6		
Start-up settling time	6		
Influence of ambient temperature	6		
Integration time	7		
Factory calibration	7		
Installation	8		
Installation instructions	8		
Environment	8		
Ambient temperature range	8		
Ambient temperature limits	8		
Storage temperature	8		
Climate class	8		
Degree of protection	8		
Shock resistance	8		
Vibration resistance (with min. rod length 150 mm)	8		
Electromagnetic compatibility	8		
Process	9		
Environment	9		
Conductivity of medium	9		
Process pressure	9		
Mechanical construction	10		
Design, dimensions	10		
Probe shortening set	10		
Weight	11		
Material	11		

Function and system design

Measuring principle

The probe, medium and ground rod (counter electrode) form an electric capacitor.

If the probe is in the air ①, a certain low initial capacitance is measured.

When the tank is filled, the capacitance of the capacitor increases the more the probe is covered ② ③.

As a conductivity of $30 \mu\text{s}/\text{cm}$, the measurement does not depend on the dc-value of the liquid.

The electronic insert of the probe converts the capacitance measured to a current, in proportion to the level, in the range of 4...20 mA, thus making it possible to interpret the level.

All input and output channels are safely galvanically isolated from one another.

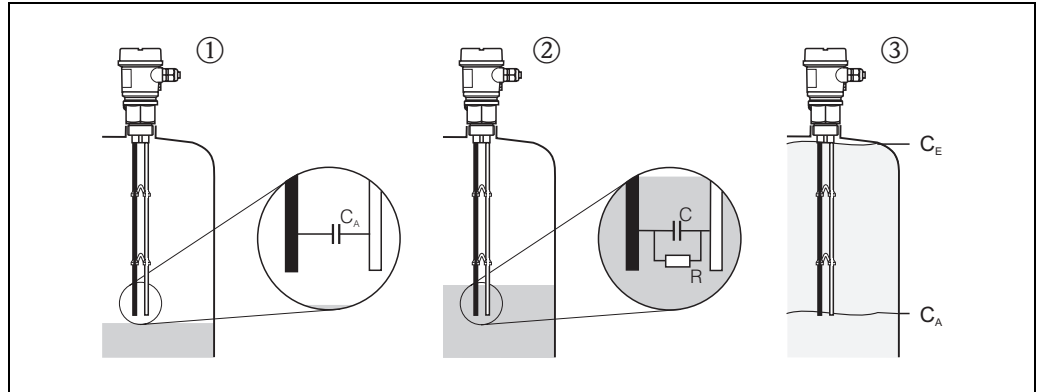

L00-FMI21 xxx-15-05-xx-xx-001

C_A : Initial capacitance (probe exposed)

C_E : Final capacitance (probe covered)

Measuring system

Probe with integrated electronic insert

The measuring system consists of:

- The components of a capacitive probe Liquicap T FMI21:
 - ① Housing with two probe rods (one probe rod fully insulated and the second uninsulated (ground potential))
 - ② Electronic insert FEI20
 - ③ Display (optional)
 - ④ Housing cover (optional: cover with sight glass in conjunction with display)
- A transmitter power supply unit

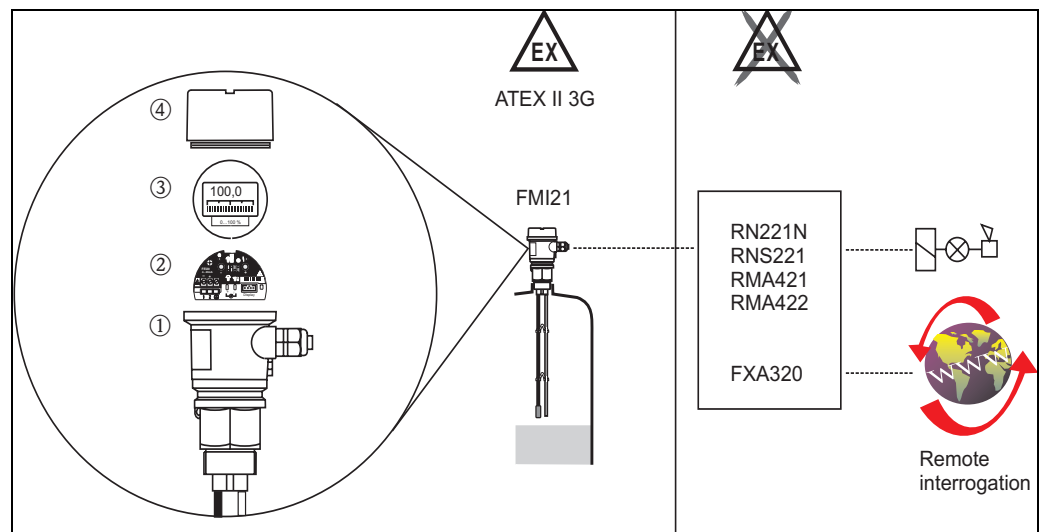

L00-FMI21 xxx-14-05-xx-en-000

Operating medium

Due to the probe design, the Liquicap T FMI21 can be used as a conductivity of 30 $\mu\text{S}/\text{cm}$. The measurement is independent of the dc-value and the conductivity of the liquid.

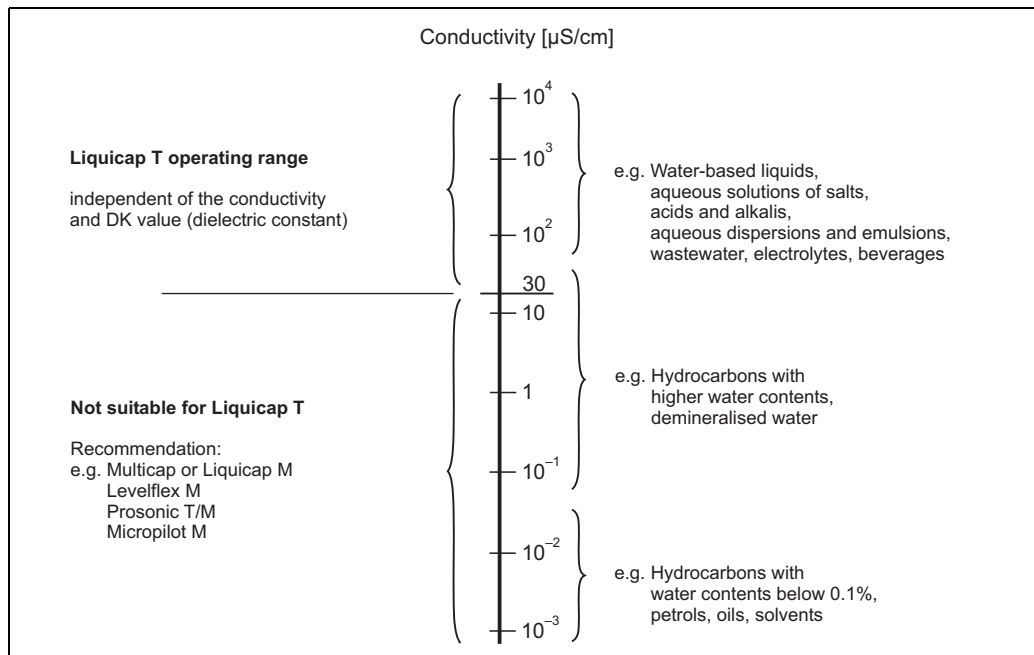

L00-FMI21xxx-05-06-xx-en-000

Applications

Vendor Managed Inventory

The remote interrogation of tank or silo levels via Fieldgate enables suppliers of raw materials to gather information about the current inventories of their regular customers at any time and, for example, take this into account in their own production planning. The Fieldgate monitor the configured level limits and automatically trigger the next delivery as required. Here, the spectrum of possibilities ranges from a simple purchasing requisition by e-mail through to fully automatic order processing by incorporating XML data into the planning systems on both sides.

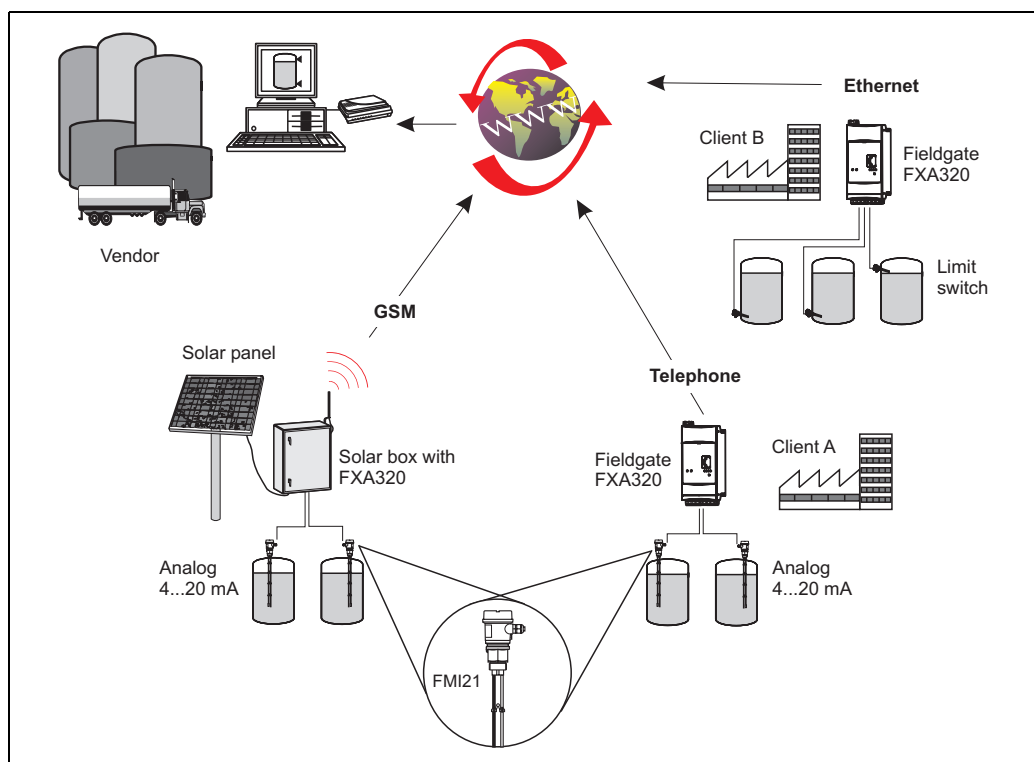

L00-FMI21xxx-02-00-06-en-001

Input

Measured variable	Continuous measurement of the change in capacitance between two probe rods depending on the level of a conductive liquid. Maximum viscosity = 2000 cst
Measuring range	The measuring range is between 150...2500 mm, depending on the probe length ordered. <ul style="list-style-type: none"> ■ Probe length: 150...2500 mm ■ Adjustable initial capacitance: $C_A = 0...2000$ pF ■ Permitted span: $\Delta C = 25...2000$ pF ■ End capacitance: $C_E = \text{max. } 2100$ pF ■ Measuring frequency: 250 kHz
Input signal	Probes covered => high capacitance Probes exposed => low capacitance

Output

Electronic insert FEI20 (4...20 mA)	Output signal	3.8...20.5 mA
	Switch-on current	Max. 20 mA (< 500 ms)
	Signal on alarm	> 21 mA

Power supply

Electrical connection (wiring diagram) FMI21 with electronic insert FEI20 for connection to transmitter power supply units from Endress+Hauser.

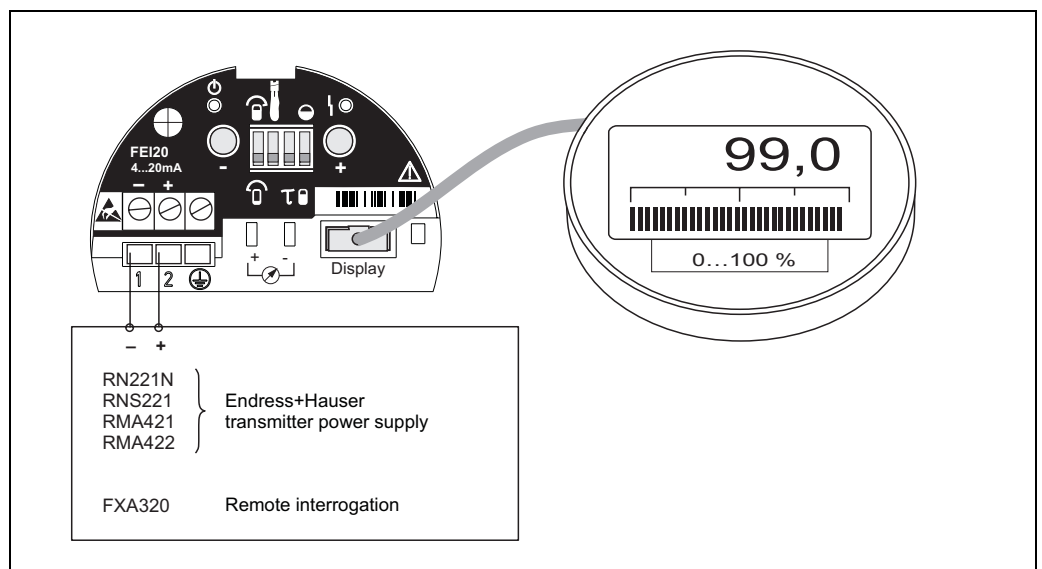

Connection of the electronic insert FEI20

100-FMI21xxx-04-05-xx-en-000

Transmitter power supply units from Endress+Hauser**RNS221**

Supply unit for supplying power to two 2-wire sensors or transmitters in the "non-Ex area".

RN221N

Active barrier with power supply for intrinsically safe separation of 4...20 mA standard signal circuits.

RMA421

Multi-functional 1-channel top-hat rail device with universal input, transmitter power supply, limit value monitoring and analog output.

RMA422

Multi-functional 1-2-channel top-hat rail device with intrinsically safe current inputs and transmitter power supply, limit value monitoring, mathematics functions and 1-2 analog outputs.

FXA320

Gateway to remote interrogation of sensors and actuators via Internet technology.

Supply voltage (FEI20)

- Connection voltage: $U = 10...30$ V DC
- Reverse polarity protection (integrated)

Power consumption

- $P < 0.7$ W

Current consumption

- $I < 22$ mA

Cable entries**M 20x1.5**

- Degree of protection: IP66
- Number in F16 housing: 2 cable entries (1 cable gland included in scope of delivery)

NPT ½

- Number in F16 housing: 2 cable entries with dummy plugs

Cable specifications

Use usual commercial two-core or multi-core cable (25 Ω per core).
Cable cross-section (incl. ferrule): max. 2.5 mm²



Note!

Use a screened cable in the event of strong, electromagnetic EMC condition.

Performance characteristics with installed electronic insert

Reference operating conditions

- Ambient temperature: 23 °C
- Medium temperature: 23 °C
- Medium viscosity: medium must expose probe again (drain off < 2000 cst)
- Atmospheric pressure
- Probe installation: vertical from above

Maximum measured error

≤ 1 % of full scale value (active rod probe)

Repeatability

0.25 % of full scale value (range 0...2000 pF)

Start-up settling time

< 2 s (stable measured value after switch-on process)

Influence of ambient temperature

< 0.01 %/K (-40°C...+70 °C) probe length 1 m

Integration time

$\tau = 1 \text{ s}$ or 0 s (adjustable)

The integration time affects the speed at which the display and the current output react to changes in the fluid level.

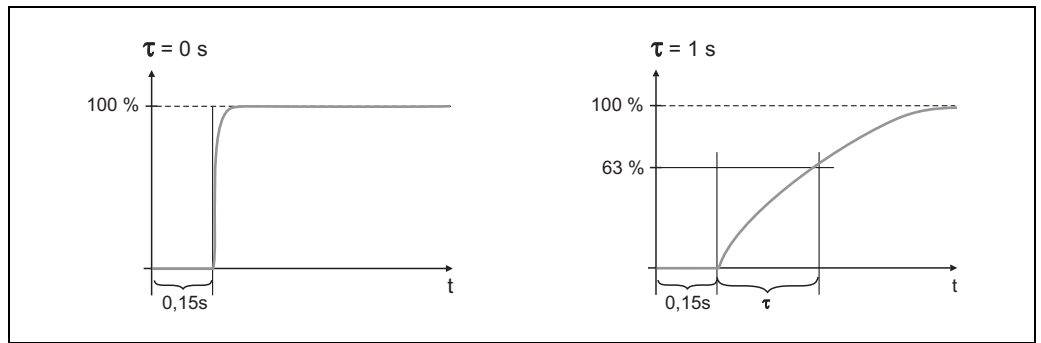

L100-FMI21xxxx-15-05-xx-xx-000

Factory calibration

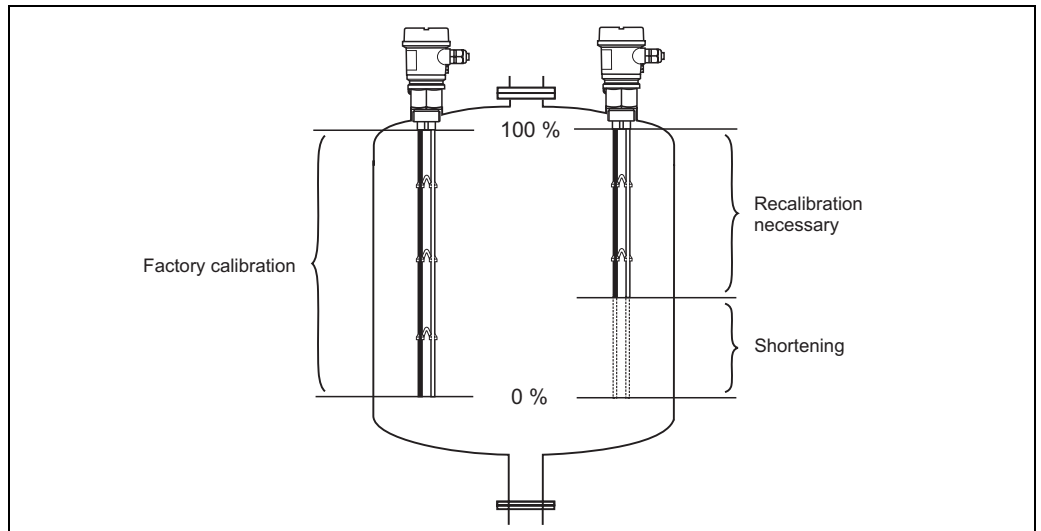

L100-FMI21xxxx-15-05-xx-xx-000

Factory calibration: medium conductivity $\geq 30 \mu\text{S}/\text{cm}$
 Calibration accuracy 100 % max. -5 mm; 0 % max. -5 mm

In an installed state, recalibration is only necessary if

- The probe rods have been shortened
- The 0 % and 100 % value should be adjusted to suit customer specifications
- The electronic insert was changed

Installation

Installation instructions

Mounting location

e.g. storage area and buffer tank.

Orientation (vertical)

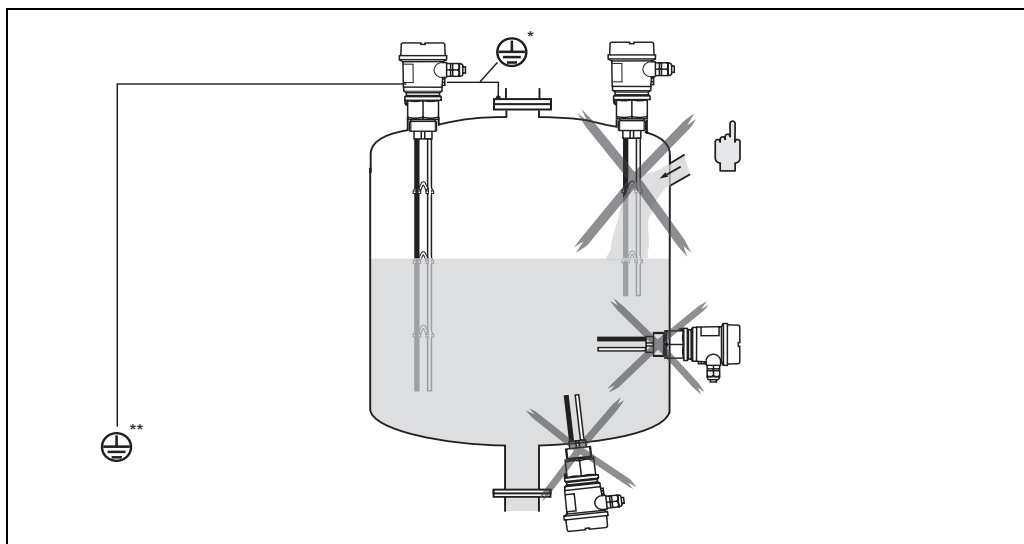

* Metal tank

** Plastic tank



Note!

The probe rods should never be in contact with the tank.



Note!

In the case of elevated electromagnetic radiation: protective ground should be attached to the device by a possibly short line.

Environment

Ambient temperature range	Ambient temperature for the electronic: -40...70 °C The functionality of the display may be limited for temperatures $T_a < -20$ °C and $T_a > +60$ °C
Ambient temperature limits	-40...80 °C (in limit range: restricted accuracy)
Storage temperature	-40...80 °C
Climate class	Suitable for the tropics as per DIN IEC 68 Part 2-38
Degree of protection	IP66
Shock resistance	DIN EN 60068-2-27 / IEC 68-2-27: 30 g
Vibration resistance (with min. rod length 150 mm)	DIN EN 60068-2-64 / IEC 68-2-64: 20...2000 Hz, 1 (m/s ²) ² /Hz
Electromagnetic compatibility	Interference emission to EN 61326, Electrical equipment Class B; Interference immunity to EN 61326, Annex A (Industrial)

Process

Environment

Permitted ambient temperature T_a at the housing depending on the process temperature T_p in the tank:

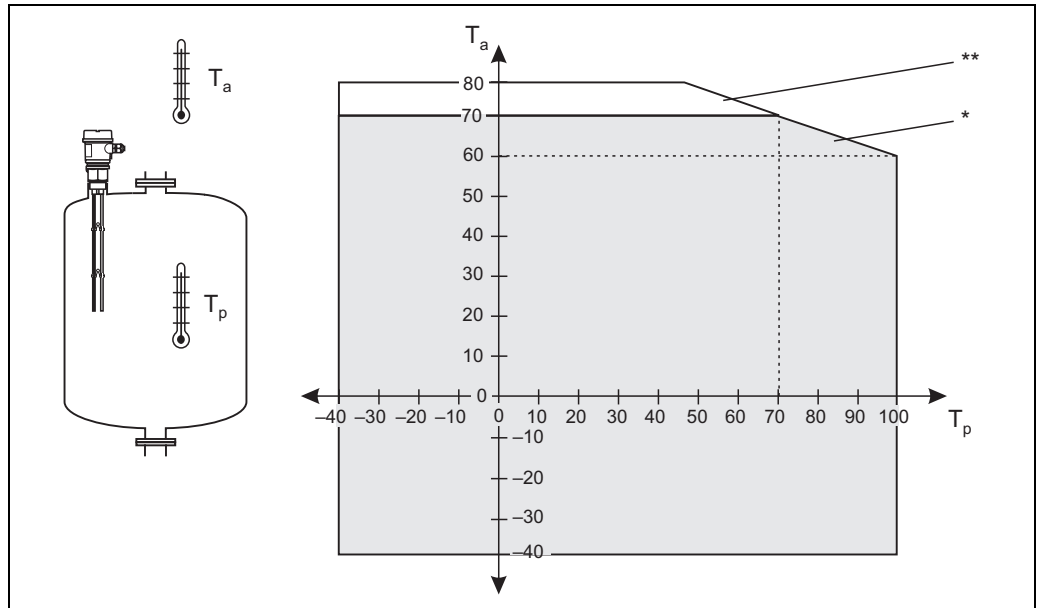

L100-FMI21.xxx-05-05-xx-xx-000

- * Permitted work range
- ** Work range with restricted accuracy

Conductivity of medium

$\geq 30 \mu\text{S}/\text{cm}$

Process pressure

-1...10 bar

Permitted process temperature T_p ($^{\circ}\text{C}$) related to the process pressure P_p (bar).

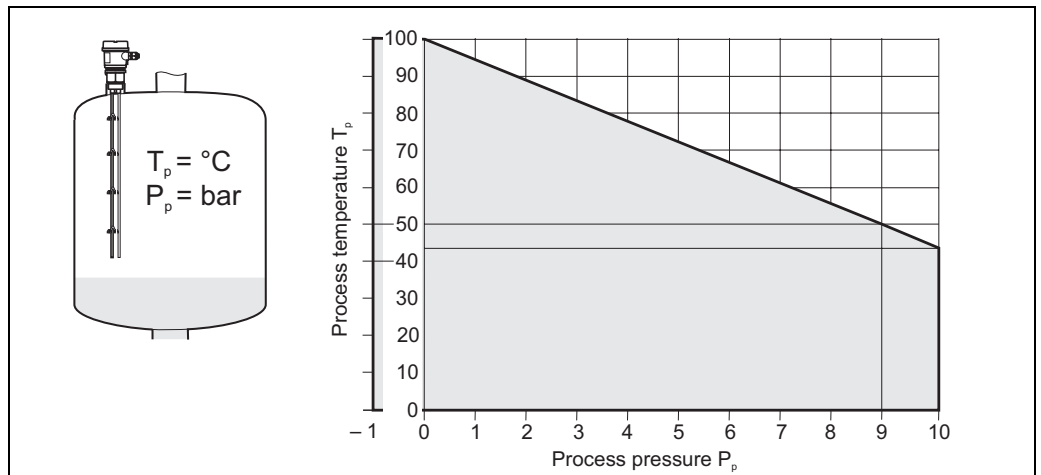

L100-FMI21.xxx-15-05-xx-xx-003

Mechanical construction



Note!
All dimensions in mm (100 mm = 3.94 in)

Design, dimensions

Rod probe

Process connection with parallel thread G 1½ or with tapered thread NPT 1½.

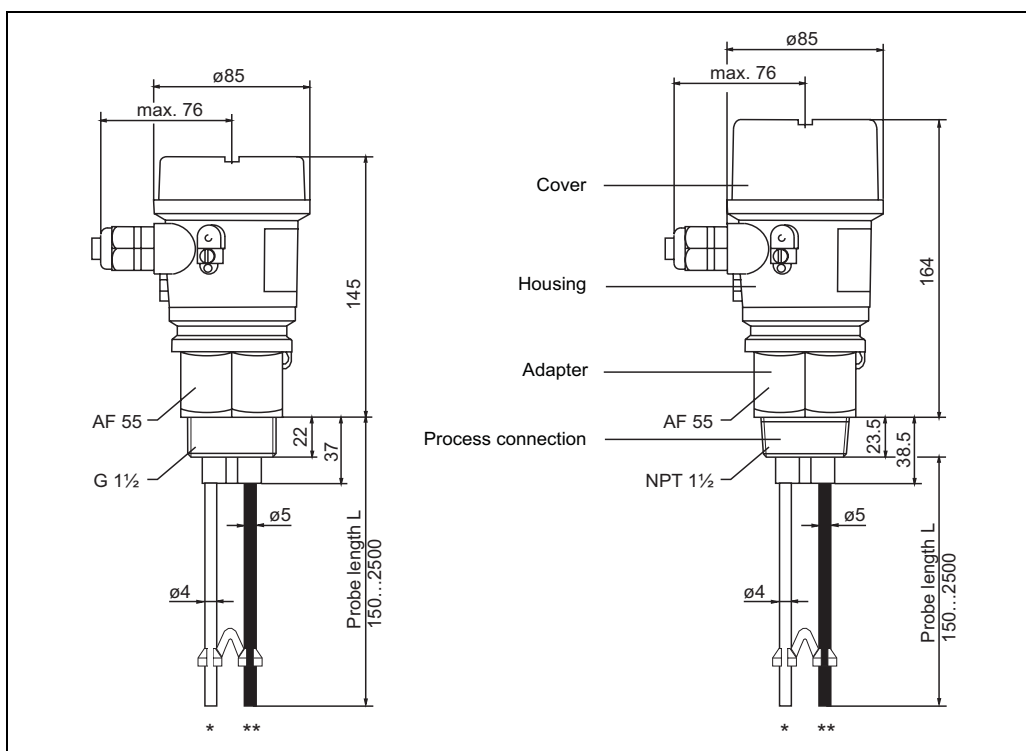

L00-FMI21xxx-06-05-xx-es-000

* Ground rod (uninsulated)
** Probe rod insulated

Probe shortening set

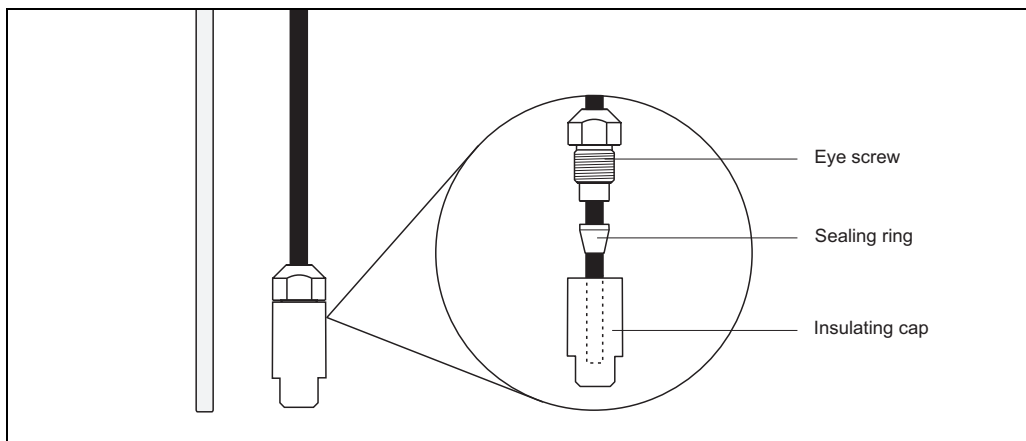

L00-FMI21xxxx-17-06-xx-es-000



Note!
If shortening the probe rods, the insulation above the cut must not be damaged!
Recalibration is always necessary after shortening the probe. The active rod probe begins above the probe shortening set. Therefore the zero balance should be carried out at this place. Only the insulated rod must be insulated with the shortening set. The ground rod remains uninsulated.

Weight**Rod 1 m length**FMI21 = 600 g

Material**Probe rods**

- Rod: 1.4404/316L - (use in water-based media, alkalis ...)
Optional: carbon fibre CFC - (use in acids e.g. hydrochloric acid)
- Sealing ring: EPDM
- Insulation: PP
- Spacer: PP
- Probe shortening set: PP

Housing F16

- Housing: PBT-FR
- Cover: PBT
- Cover with sight glass: PA
- Cable gland: PA
- Adapter: PBT
- Dummy plug: PBT

Process connections

- G 1½ A (PPS, DIN ISO 228/1)
- NPT 1½ (PPS, ANSI B 1.20.1)

Seals

- Seal between housing and process connection: EPDM
 - Seal for plastic housing cover F16: EPDM
 - Sealing ring for process connection G 1½ A: elastomer fibre asbestos-free (resistant to oils, solvents, steam, weak acids and alkalis)
-

Fitted electrodes**Rod probe with two rods**

- Rod diameter without insulation: 4 mm
- Maximum rod length: 2500 mm
- Minimum rod length: 150 mm
- Insulation thickness: 0.5 mm
- Extraction forces (parallel probe rod): 1000 N
- Lateral loading capacity: 2 Nm

Human interface

Operating elements



Electronic insert FEI20

Note!

The display indicates no comma, if the probe length is < 200 mm.

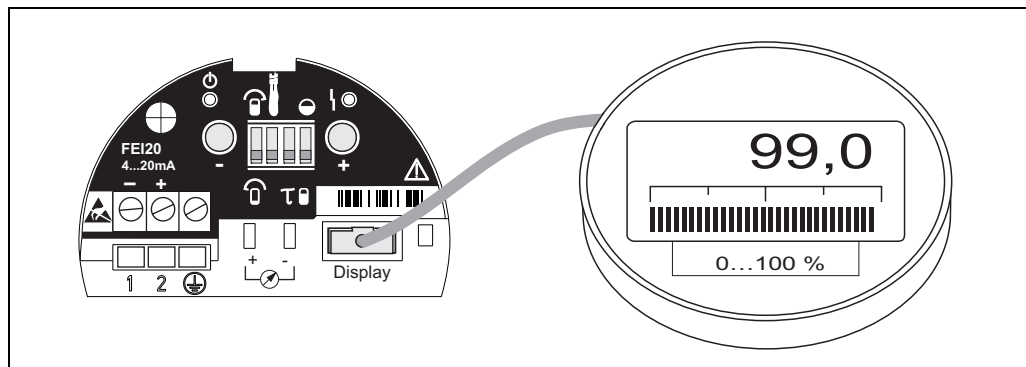

L00-FMI21xxx-07-05-zx-zx-000

- Key (-)
- Key (+)
- 4...20 mA current pick-off, e.g. for full/empty calibration with multimeter.
(No need to disconnect circuit!)
- Display connection
- DIL switch (from left to right):
 - Probe calibration type (full/empty)
 - Mode of operation (Normal mode/Build-up mode (smut and build up e.g. hydrochloric acid.))
 - Output damping (0 s / 1 s)
 - Linearisation (only for horizontal cylindrical tanks)

Linearisation (for cylindrically lying tanks):

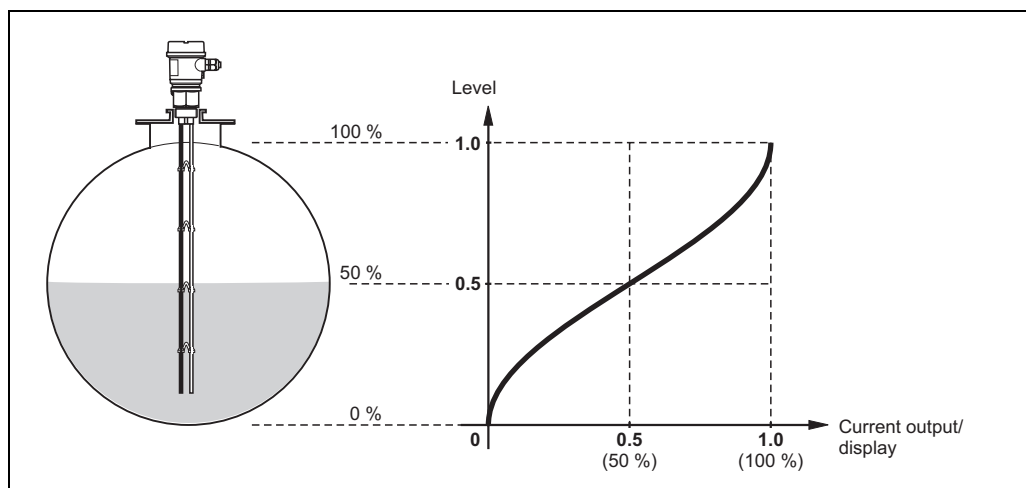

L00-FMI21xxx-15-05-zx-zx-001



Note!

In cylindrically lying tanks the current output and display are in proportion to the volume.

Display elements

FEI20

- A red light emitting diode: as alarm or warning (flashing)
- A green light emitting diode: to indicate operational status (flashes every 5 sec. approx.) or to confirm key entries
- Display (optional) for measured value in %, bargraph for minimum and maximum probe capacitance.

Certificates and approvals

CE mark	<p>The Liquicap T is in conformity with the statutory requirements of the EC Directives. Endress+Hauser confirms that the device has been tested successfully by applying the CE mark.</p> <p>CSA/US; General Purpose (GP) Kanada, USA</p>
Overfill protection	<p>Approvals</p> <ul style="list-style-type: none">■ German Water Resources Law (WHG) - see commissioning notes in ZE263F (Z. 65.xx - xxx)
Other standards and guidelines	<ul style="list-style-type: none">■ Low Voltage Directive (73/23/EEC)■ DIN EN 61010 Part 1, 2001 Protection Measures for Electrical Equipment for Measurement, Control, Regulation and Laboratory Procedures. Part 1: General Requirements■ CAN/CSA-C22.2 No. 1010.1-92 Safety Requirements for Electrical Equipment for Measurement, Control, and Laboratory Use; Part 1: General Requirements (Includes Amendment 1)■ UL Std No. 61010C-1 Process Control Equipment; Part 1: General Requirements■ EN 61326 Electrical Equipment for Measurement, Control and Laboratory Use EMC Requirements■ EN 50021 Electrical Apparatus for Potentially Explosive Atmospheres Specification for Electrical Apparatus with Type of Protection "n"
Ex approval	<p>ATEX II 3 G EEx nA IIC T6</p> <p>All explosion protection data are given in a separate documentation (see: Documentation) which is available upon request.</p>
Type of protection	EEx nA IIC T6 (non-sparking equipment)

Ordering information

Liquicap T FMI21

10	Approval:	
	A	Non-hazardous area
	B	Non-hazardous area, WHG
	C	ATEX II 3 G EEx nA IIC T6, WHG
	D	CSA General Purpose, CSA C US
	Y	Special version
20	Process Connection:	
	1	Thread ISO228 G 1½, PPS
	2	Thread ANSI NPT 1½, PPS
	9	Special version
30	Probe Length; Material; 150...2500 mm (6...100 inch):	
	A	... mm L, PP 316L
	B	... mm L, PP carbon fiber (< 1000 mm)
	C	... mm L, PP carbon fiber (> 1000 mm)
	D	... inch L, PP 316L
	E	... inch L, PP carbon fiber (< 40 inch)
	F	... inch L, PP carbon fiber (> 40 inch)
	Y	Special version
40	Housing; Cable Entry:	
	1	F16 polyester IP66 NEMA4X; gland M20
	2	F16 polyester IP66 NEMA4X; thread NPT ½
	3	F16 polyester IP66 NEMA4X; thread G ½
	9	Special version
50	Electronics; Output:	
	A	None
	B	FEI20; 4...20 mA
	C	FEI20; 4...20 mA + display
	Y	Special version
60	Additional Option:	
	1	Basic version
	2	Shortening kit PP
	9	Special version
995	Marking:	
	1	Tagging (TAG)
FMI21	Complete product designation	

Accessories

Liquicap T

- Mounting nut G 1½
Hexagon head, AF 60
PN 52014146
- Shortening kit FMI21
PN 52024300

Spare parts

- Electronics FEI20
PN 52025603
- Cover F16 high, transparent, with gasket
PN 52025605
- Cover F16 grey, PBTP, with gasket
PN 52025606
- Digital display, with holder
PN 52025604
- Spacer probe rods, 5 pieces (5 pieces are included in the scope of delivery)
PN 52025607

Documentation



Note!

The specified documentations are available under www.endress.com.

Technical Information

- Gateways / interfaces
Fieldgate FXA320
TI369F/00
 - Process transmitter
Preline RMA422
TI072R/09
 - Process transmitter
Preline RMA421
TI064R/09
 - Transmitter power supply unit
Preline RNS221
TI081R/09
 - Active barrier
Preline RN221N
TI073R/09
-

Operating Instructions

- Liquicap T FMI20
KA233F/00
-

Certificates

WHG (German Water Resources Law)

- Liquicap T
ZE263F/00

ATEX

- Liquicap T
II 3 G EEx nA IIC T6
XA320F/00

Instruments International

Endress+Hauser
Instruments International AG
Kaegenstrasse 2
4153 Reinach
Switzerland

Tel. +41 61 715 81 00
Fax +41 61 715 25 00
www.endress.com
info@ii.endress.com

Endress+Hauser 

TI393F/00/EN/05.10
71115363
CCS/FM+SGML6.0

