

Technical Information

Indumax CLS52

Inductive conductivity sensor with fast temperature measurement and hygienic design



Application

The CLS52 conductivity sensors are intended specifically for use in the food industry. They are injection-molded and made from high-resistance PEEK, thereby meeting the strict hygienic requirements of the food industry.

- Concentration control in the remaking of acids and alkalis
- Phase separation of product/water and product/product mixtures in pipe systems
- Monitoring and control of bottle cleaning systems
- Product monitoring in breweries, dairies and the beverage industry
- Control and monitoring of CIP systems
- Use with Liquiline CM42 and Liquisys CLM223/253 transmitters; part of the Smartec CLD132 measuring system

Your benefits

- Insensitive to electrode contamination and polarization thanks to inductive measuring principle
- Food-safe and hygienic thanks to design without joints or crevices
- Hydrodynamic sensor design for low flow resistance
- Maintenance-free due to non-contact measurement
- Very short temperature response time ($t_{90} < 5s$)
- Easy installation directly in-line using standardized process connections common in the food industry

Function and system design

Measuring principle

Inductive conductivity measurement

An oscillator (1) generates an alternating magnetic field in the primary coil (5), which induces a current flow (4) in the medium. The strength of the current depends on the conductivity and thus on the ion concentration in the medium. The current flow in the medium, in turn, generates a magnetic field in the secondary coil (3). The resulting induced current is measured by the receiver (2) and used to determine the conductivity.

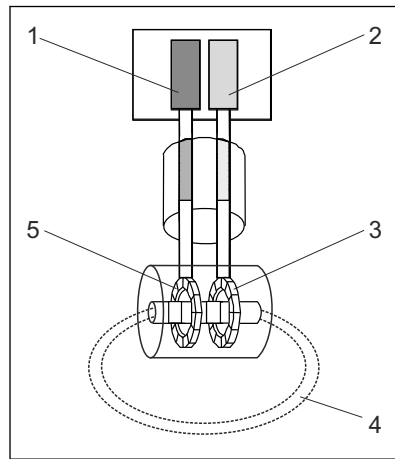

- 1 Oscillator
- 2 Receiver
- 3 Secondary coil
- 4 Current flow in the medium
- 5 Primary coil

Advantages of inductive conductivity measurement:

- No electrodes and therefore no polarization effects
- Accurate measurement in media with a high degree of pollution and a tendency to form buildup
- Complete galvanic isolation of the measurement and the medium

Important features of Indumax CLS52

- **Hygiene**
The injection-molded PEEK sensor offers outstanding chemical, mechanical and thermal resistance and is hygienically safe thanks to its seamless, crevice-free design.
- **Temperature measurement and temperature compensation**
For applications requiring fast temperature compensation (e.g. CIP return line, phase separation at different temperatures), the Pt 100 temperature sensor is installed in a stainless steel thermal conductivity socket which is sealed via a Chemraz O-ring. This guarantees very short temperature response times ($t_{90} < 5s$).
- **Process temperature**
The use of special components and materials means that the sensor is suitable for exposure to continuous temperatures of up to 125 °C. It can be operated at temperatures up to 140 °C for a short time (max. 30 min.) for sterilization purposes.
- **Process connections**
The sensor is available with all the process connections commonly used in hygienic applications.

Measuring system

A complete measuring system consists of the following components at least:

- The CLS52 inductive conductivity sensor
- A transmitter, e.g. Liquiline CM42

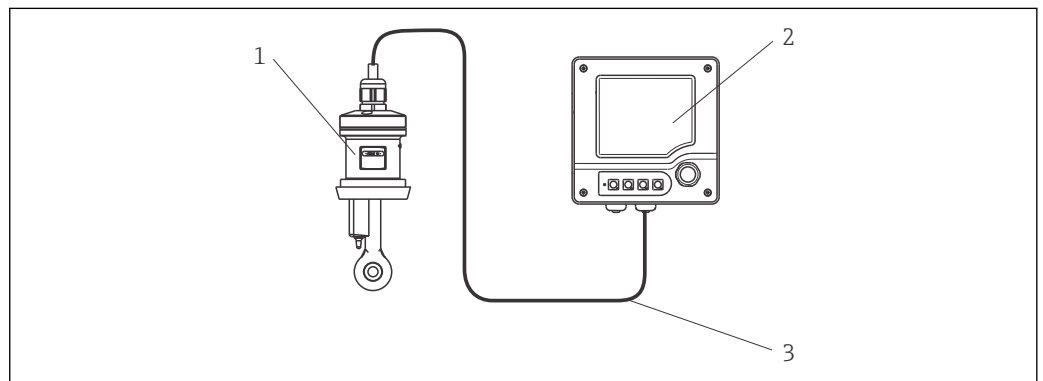

A0028357

1 Example of a measuring system

- 1 Indumax CLS52
- 2 Liquiline CM42 transmitter
- 3 Fixed cable (on the sensor)

Input

Measured values

- Conductivity
- Temperature

Measuring ranges

Conductivity	Recommended range: 100 $\mu\text{S}/\text{cm}$ to 2000 mS/cm (uncompensated)
Temperature	-5 to +140 $^{\circ}\text{C}$ (+23 to 284 $^{\circ}\text{F}$)

Cell constant

$k = 5.9 \text{ cm}^{-1}$

Temperature measurement

Pt 100 (Class A according to IEC 60751)

Power supply

Electrical connection

The sensor is supplied with a fixed cable. The wiring diagram is provided in the Operating Instructions of the transmitter used.

Connection via a VBM junction box is necessary for a cable connection. The extension to the transmitter is via the CLK6 cable.

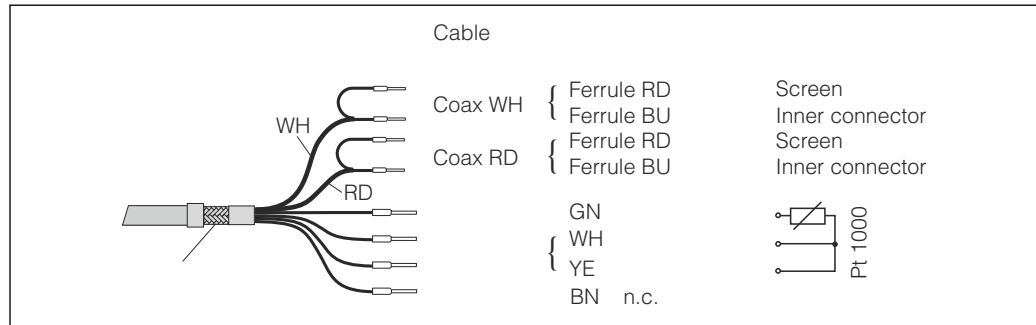

2 Fixed cable/special measuring cable CLK6

Cable length:

Max. total length of 55 m (180 ft)

Performance characteristics

Temperature response time $t_{90} < 5$ s

Maximum measured error	-5 to +100 °C (+23 to 212 °F):	$\pm(10 \mu\text{S}/\text{cm} + 0.5 \% \text{ of reading})$
	> 100 °C (212 °F):	$\pm(30 \mu\text{S}/\text{cm} + 0.5 \% \text{ of reading})$

Installation

Orientation

The sensor must be completely immersed in the medium. Avoid air bubbles in the area of the sensor.

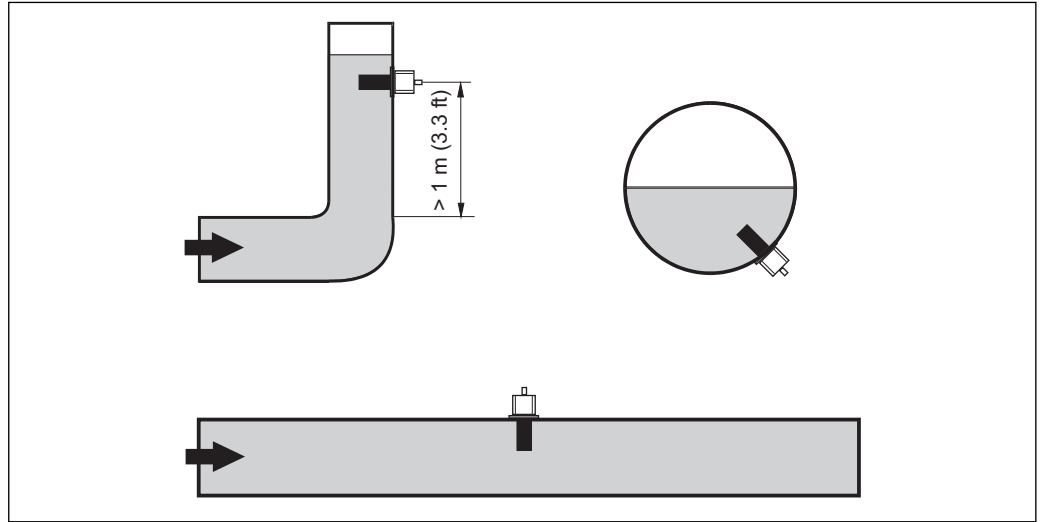

A0017691

3 Installation positions of the conductivity sensor

i If the flow direction changes (after pipe bends), turbulence in the medium can result. Install the sensor at a distance of at least 1 m (3.3 ft) downstream from a pipe bend.

The medium must flow through the conical measuring channel in the direction indicated.

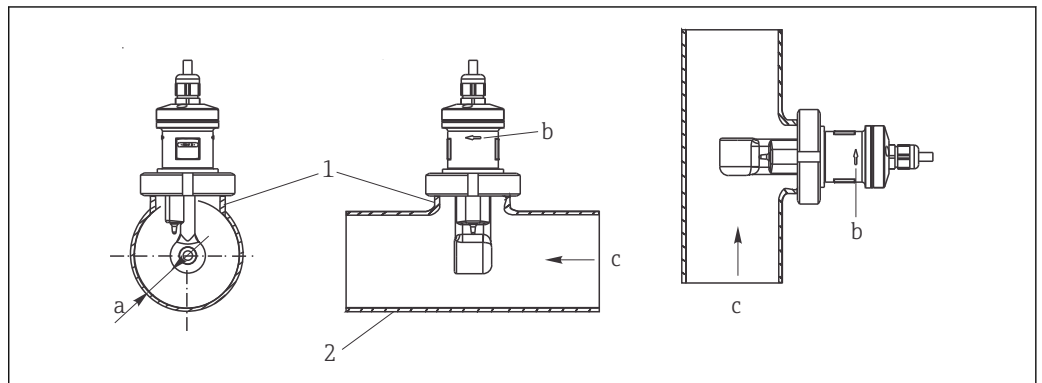

A0028424

4 Installation of CLS52 in pipes with horizontal flow (center) and vertical flow (right)

- a Sensor distance from wall
- b Indicator arrow for flow direction
- c Direction of flow
- 1 Welding socket
- 2 Pipe

Installation factor

The ionic current in the liquid is affected by the walls in confined installation conditions. This effect is compensated by what is referred to as the installation factor. The installation factor can be entered in the transmitter for the measurement or the cell constant is corrected by multiplying by the installation factor.

The value of the installation factor depends on the diameter and the conductivity of the pipe nozzle as well as the distance a between the sensor and the wall.

The installation factor ($f = 1.0$) can be disregarded if the distance to the wall is sufficient ($a > 15$ mm, from DN 65).

If the distance to the wall is smaller, the installation factor increases for electrically insulating pipes ($f > 1$), and decreases for electrically conductive pipes ($f < 1$).

It can be measured using calibration solutions, or a close approximation can be determined from the adjacent diagram.

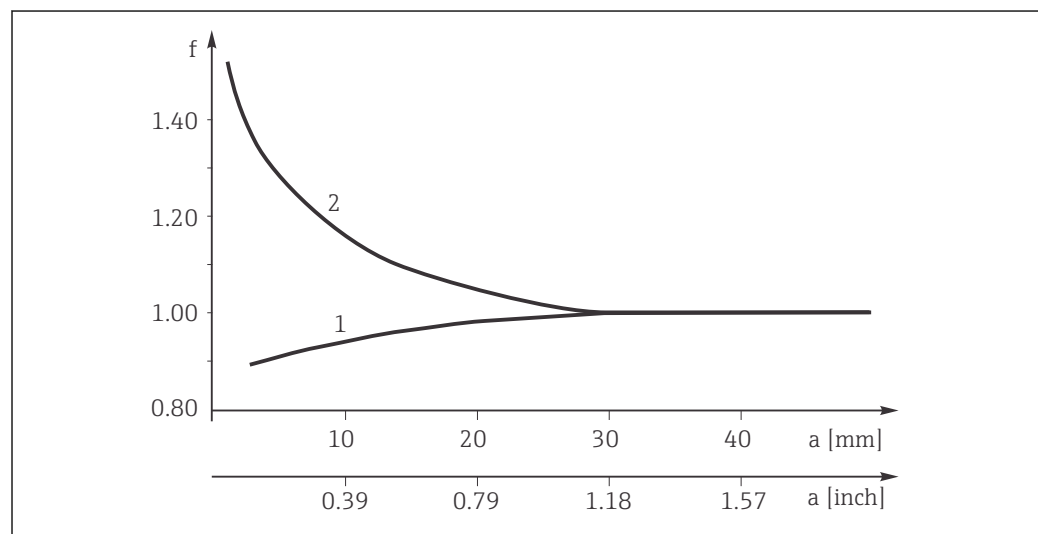

5 Relationship between installation factor f and wall distance a

- 1 Conductive pipe
2 Insulating pipe

Air set

To compensate residual coupling in the cable and between the two sensor coils, zero adjustment in air ("air set") must be performed before installing the sensor. Follow the instructions provided in the Operating Instructions of the transmitter used.

Environment

Ambient temperature range -10 to +70 °C (+10 to +160 °F)

Storage temperature -25 to +80 °C (-13 to +176 °F)

Humidity 5 to 95 %

Degree of protection IP 67 / NEMA 6

Process

Process temperature	-5 to +125 °C (+21 to +257 °F)
Sterilization	140 °C (284 °F) / 4 bar (58 psi) (max. 30. min.)
Process pressure (absolute)	17 bar (264.5 psi) up to 90 °C (194 °F)

Temperature/pressure ratings

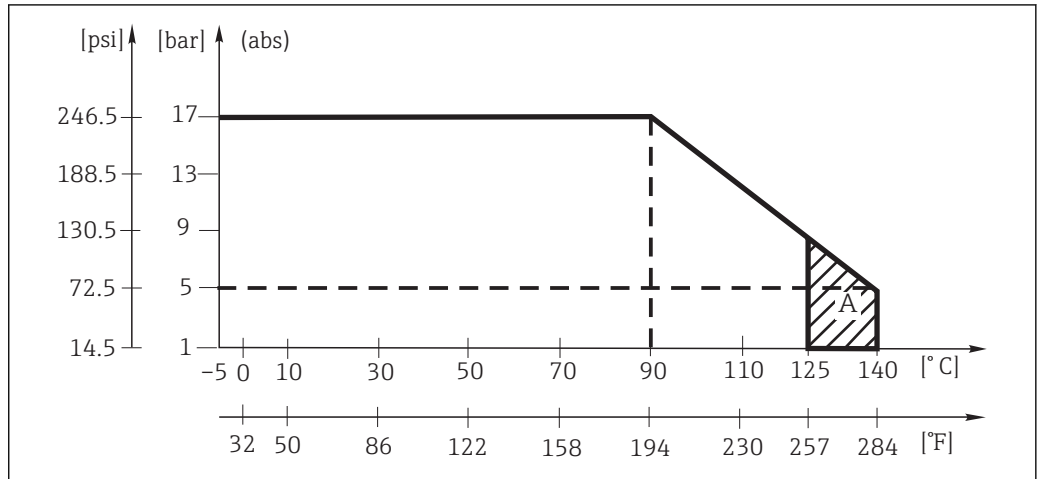

A0028355

6 A = Temporarily for sterilization (max. 30 min.)

Mechanical construction

Design

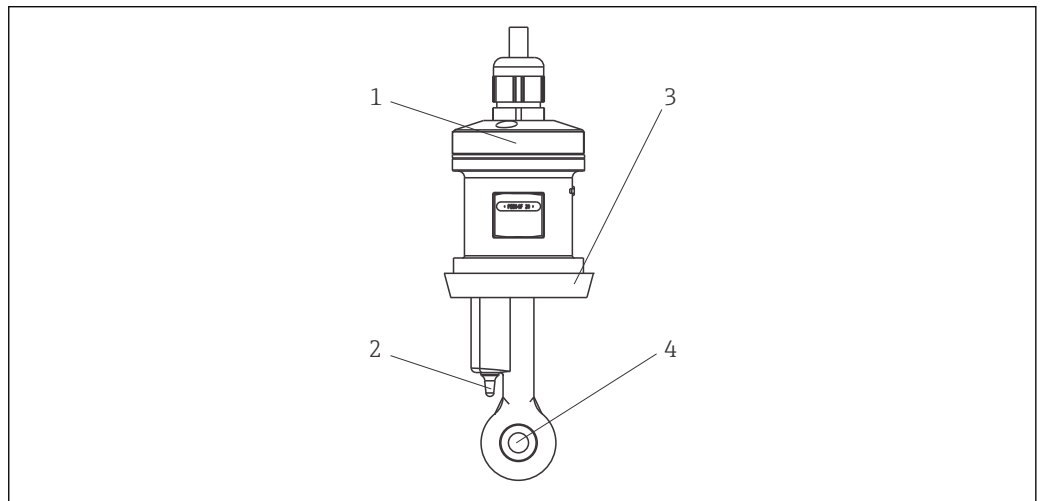

A0028354

7 Indumax CLS52

- 1 Housing
- 2 Temperature sensor
- 3 Process connection
- 4 Flow opening

Dimensions

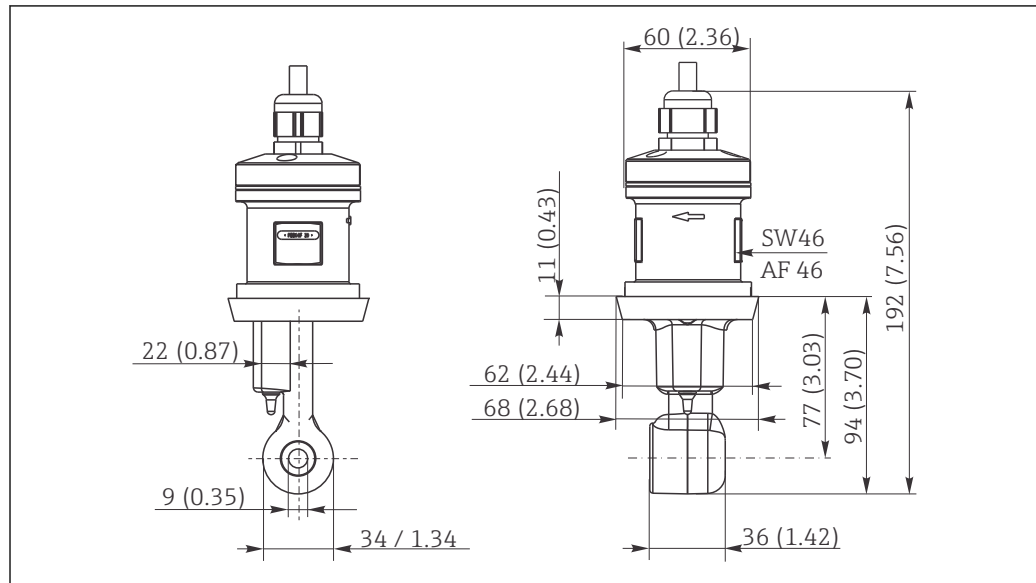

8 Dimensions of CLS52 in mm(inch)

A0028353

Weight

0.4 to 0.8 kg (0.88 to 1.76 lb.) depending on version

Materials

Sensor:	PEEK-GF20
Varivent flange:	
Flange:	Stainless steel 1.4435 (AISI 316L)
Seal:	EPDM
Metal temperature sensor socket:	
Socket:	Stainless steel 1.4435 (AISI 316L)
Seal:	Chemraz

Process connections

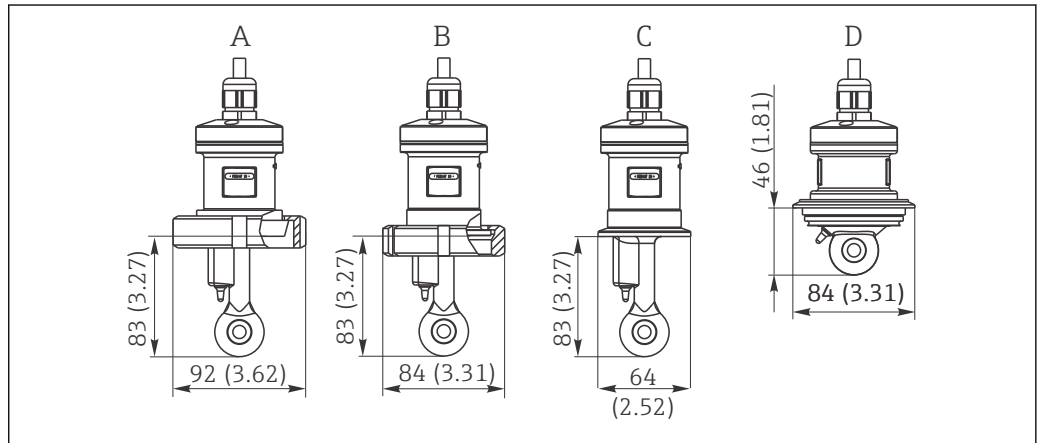

A0028358

9 Process connections for CLS52, dimensions in mm(inch)

- A Sanitary connection DN 50 (DIN 11851)
- B SMS 2"
- C Clamp 2" (ISO 2852)
- D Varivent N DN 40 to DN 125

i Clamp connection

Both sheet-metal brackets and solid brackets can be used to secure the sensor. Sheet-metal brackets have a lower dimensional stability, uneven bearing surfaces causing point loads, and sometimes sharp edges that can damage the clamp.

We urgently recommend you only use solid brackets due to their higher dimensional stability. Solid brackets can be used over the entire specified pressure/temperature range.

Chemical resistance

Medium	Concentration	PEEK	1.4435	CHEMRAZ	EPDM
Sodium hydroxide solution NaOH	0 to 10 %	20 to 100 °C (68 to 212 °F)	20 to 90 °C (68 to 194 °F)	20 to 100 °C (68 to 212 °F)	20 to 100 °C (68 to 212 °F)
	0 to 50 %	20 to 100 °C (68 to 212 °F)	20 to 90 °C (68 to 194 °F)	20 to 100 °C (68 to 212 °F)	20 to 60 °C (68 to 140 °F)
Nitric acid HNO ₃	0 to 10 %	20 to 100 °C (68 to 212 °F)	20 to 100 °C (68 to 212 °F)	20 to 100 °C ¹⁾ (68 to 212 °F) ¹⁾	20 °C (68 °F)
	0 to 25 %	20 to 40 °C (68 to 104 °F)	20 to 100 °C (68 to 212 °F)	20 to 100 °C ¹⁾ (68 to 212 °F) ¹⁾	Cannot be used
Phosphoric acid H ₃ PO ₄	0 to 10 %	20 to 100 °C (68 to 212 °F)	20 to 100 °C (68 to 212 °F)	20 to 100 °C (68 to 212 °F)	20 to 80 °C (68 to 176 °F)
	0 to 30 %	20 to 100 °C (68 to 212 °F)	20 to 85 °C (68 to 185 °F)	20 to 100 °C (68 to 212 °F)	20 to 80 °C (68 to 176 °F)
Sulfuric acid H ₂ SO ₄	0 to 2.5 %	20 to 100 °C ¹⁾ (68 to 212 °F) ¹⁾	20 to 70 °C (68 to 158 °F)	20 to 100 °C (68 to 212 °F)	20 to 30 °C (68 to 86 °F)
	0 to 30 %	20 to 100 °C ¹⁾ (68 to 212 °F) ¹⁾	Cannot be used	20 to 100 °C (68 to 212 °F)	20 to 30 °C (68 to 86 °F)

1) Slight corrosion possible
Errors and omissions excepted

Certificates and approvals

CE mark

Declaration of Conformity

The product meets the requirements of the harmonized European standards. As such, it complies with the legal specifications of the EC directives. The manufacturer confirms successful testing of the product by affixing to it the CE mark.

Ordering information

Product page	www.endress.com/cls52
Product Configurator	<p>The navigation area is located on the right of the product page.</p> <ol style="list-style-type: none"> 1. Under "Device support" click "Configure your selected product". <ul style="list-style-type: none"> ↳ The Configurator opens in a separate window. 2. Select all the options to configure the device in line with your requirements. <ul style="list-style-type: none"> ↳ In this way, you receive a valid and complete order code for the device. 3. Export the order code as a PDF or Excel file. To do so, click the appropriate button at the top of the screen.
Scope of delivery	<p>The scope of delivery includes:</p> <ul style="list-style-type: none"> ▪ Sensor in the version ordered ▪ Operating Instructions

Accessories

 The following are the most important accessories available at the time this documentation was issued. For accessories not listed here, please contact your service or sales office.

Cable extension	<p>Measuring cable</p> <p>Measuring cable CLK6</p> <ul style="list-style-type: none"> ▪ Extension cable for inductive conductivity sensors, for extension via VBM junction box ▪ Sold by the meter, order number: 71183688 <p>Junction box</p> <p>VBM</p> <ul style="list-style-type: none"> ▪ Junction box for cable extension ▪ 10 terminal strips ▪ Cable entries: 2 x Pg 13.5 or 2 x NPT ½" ▪ Material: aluminum ▪ Degree of protection: IP 65 ▪ Order numbers <ul style="list-style-type: none"> – Cable entries Pg 13.5 : 50003987 – Cable entries NPT ½": 51500177 <p>Desiccant pouch</p> <ul style="list-style-type: none"> ▪ Desiccant pouch with color indicator for VBM junction box ▪ Order No. 50000671
Calibration solutions	<p>Conductivity calibration solutions CLY11</p> <p>Precision solutions referenced to SRM (Standard Reference Material) by NIST for qualified calibration of conductivity measuring systems in accordance with ISO 9000</p> <ul style="list-style-type: none"> ▪ CLY11-B, 149.6 µS/cm (reference temperature 25 °C (77 °F)), 500 ml (16.9 fl.oz) Order No. 50081903 ▪ CLY11-C, 1.406 mS/cm (reference temperature 25 °C (77 °F)), 500 ml (16.9 fl.oz) Order No. 50081904 ▪ CLY11-D, 12.64 mS/cm (reference temperature 25 °C (77 °F)), 500 ml (16.9 fl.oz) Order No. 50081905 ▪ CLY11-E, 107.00 mS/cm (reference temperature 25 °C (77 °F)), 500 ml (16.9 fl.oz) Order No. 50081906 <p> Technical Information TI00162C</p>



www.addresses.endress.com
