

Operating Instructions

Indumax CLS52

Conductivity sensor

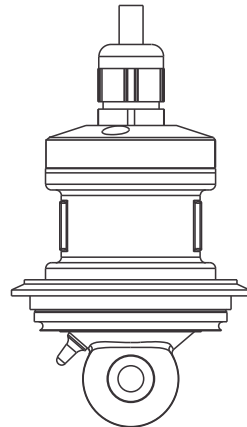
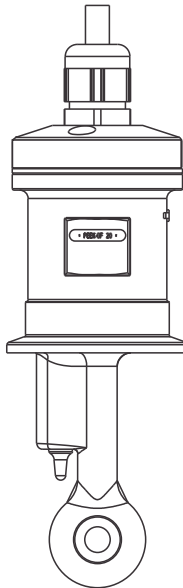





Table of contents







1	Document information	4
1.1	Warnings	4
1.2	Symbols used	4
1.3	Symbols on the device	5
2	Basic safety instructions	6
2.1	Requirements for the personnel	6
2.2	Designated use	6
2.3	Occupational safety	6
2.4	Operational safety	7
2.5	Product safety	7
3	Incoming acceptance and product identification	7
3.1	Incoming acceptance	7
3.2	Scope of delivery	7
3.3	Product identification	8
3.4	Certificates and approvals	9
4	Installation	9
4.1	Measuring system	9
4.2	Design	10
4.3	Installation conditions	10
4.4	Dimensions	13
4.5	Post-installation check	14
5	Electrical connection	15
5.1	Connecting to the transmitter	15
5.2	Ensuring the degree of protection	15
5.3	Post-connection check	16
6	Maintenance	16
7	Repairs	17
7.1	Return	17
7.2	Disposal	17
8	Accessories	17
8.1	Cable extension	17
8.2	Calibration solutions	18
9	Technical data	18
	Index	22

1 Document information

1.1 Warnings

Structure of information	Meaning
 <p>Causes (/consequences) If necessary, Consequences of non-compliance (if applicable) ▶ Corrective action</p>	<p>This symbol alerts you to a dangerous situation. Failure to avoid the dangerous situation will result in a fatal or serious injury.</p>
 <p>Causes (/consequences) If necessary, Consequences of non-compliance (if applicable) ▶ Corrective action</p>	<p>This symbol alerts you to a dangerous situation. Failure to avoid the dangerous situation can result in a fatal or serious injury.</p>
 <p>Causes (/consequences) If necessary, Consequences of non-compliance (if applicable) ▶ Corrective action</p>	<p>This symbol alerts you to a dangerous situation. Failure to avoid this situation can result in minor or more serious injuries.</p>
 <p>Cause/situation If necessary, Consequences of non-compliance (if applicable) ▶ Action/note</p>	<p>This symbol alerts you to situations which may result in damage to property.</p>

1.2 Symbols used

Symbol	Meaning
	Additional information, tips
	Permitted or recommended
	Not permitted or not recommended
	Reference to device documentation
	Reference to page
	Reference to graphic
	Result of a step

1.3 Symbols on the device

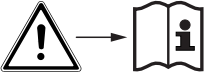
Symbol	Meaning
	Reference to device documentation

2 Basic safety instructions

2.1 Requirements for the personnel

- Installation, commissioning, operation and maintenance of the measuring system may be carried out only by specially trained technical personnel.
- The technical personnel must be authorized by the plant operator to carry out the specified activities.
- The electrical connection may be performed only by an electrical technician.
- The technical personnel must have read and understood these Operating Instructions and must follow the instructions contained therein.
- Faults at the measuring point may only be rectified by authorized and specially trained personnel.



Repairs not described in the Operating Instructions provided must be carried out only directly at the manufacturer's site or by the service organization.

2.2 Designated use

Indumax CLS52 is designed for the inductive measurement of the conductivity of liquids. The sensor is particularly suitable for use in hygienic applications in the food industry.

Use with the Liquiline CM42 and Lquisys CLM223/253 transmitters; integral part of the Smartec CLD132 measuring system.

Use of the device for any purpose other than that described, poses a threat to the safety of people and of the entire measuring system and is therefore not permitted.

The manufacturer is not liable for damage caused by improper or non-designated use.

2.3 Occupational safety

As the user, you are responsible for complying with the following safety conditions:

- Installation guidelines
- Local standards and regulations

Electromagnetic compatibility

- The product has been tested for electromagnetic compatibility in accordance with the applicable European standards for industrial applications.
- The electromagnetic compatibility indicated applies only to a product that has been connected in accordance with these Operating Instructions.

2.4 Operational safety

1. Before commissioning the entire measuring point, verify that all connections are correct. Ensure that electrical cables and hose connections are undamaged.
2. Do not operate damaged products, and safeguard them to ensure that they are not operated inadvertently. Label the damaged product as defective.
3. If faults cannot be rectified:
Take the products out of operation and safeguard them to ensure that they are not operated inadvertently.

2.5 Product safety

The product is designed to meet state-of-the-art safety requirements, has been tested, and left the factory in a condition in which it is safe to operate. The relevant regulations and European standards have been observed.

3 Incoming acceptance and product identification

3.1 Incoming acceptance

1. Verify that the packaging is undamaged.
 - ↳ Notify your supplier of any damage to the packaging.
Keep the damaged packaging until the matter has been settled.
2. Verify that the contents are undamaged.
 - ↳ Notify your supplier of any damage to the delivery contents.
Keep the damaged products until the matter has been settled.
3. Check the delivery for completeness.
 - ↳ Check it against the delivery papers and your order.
4. Pack the product for storage and transportation in such a way that it is protected against impact and moisture.
 - ↳ The original packaging offers the best protection.
The permitted ambient conditions must be observed (see "Technical data").

If you have any questions, please contact your supplier or your local sales center.

3.2 Scope of delivery

The scope of delivery includes:

- Sensor in the version ordered
- Operating Instructions

3.3 Product identification

3.3.1 Nameplate

The nameplate can be found on the sensor.

The following information is provided on the nameplate:

- Manufacturer identification
- Order code
- Extended order code
- Serial number
- Cell constant (nominal value)
- Protection class
- Pressure specification at 20 °C
- Continuous service temperature



Compare the data on the nameplate with your order.

3.3.2 Product identification

Product page

www.endress.com/cls52

Interpreting the order code

The order code and serial number of your product can be found in the following locations:

- On the nameplate
- In the delivery papers

Obtaining information on the product

1. Go to the product page for your product on the Internet.
2. At the bottom of the page, click the link **Online Tools** and then select **Access device specific information**.
 - ↳ An additional window opens.
3. Enter the order code from the nameplate into the search field and then select **Show details**.
 - ↳ You will receive information on each feature (selected option) of the order code.

Manufacturer's address

Endress+Hauser Conducta GmbH+Co. KG
Dieselstraße 24
D-70839 Gerlingen

3.4 Certificates and approvals

3.4.1 CE mark

The product meets the requirements of the harmonized European standards. As such, it complies with the legal specifications of the EU directives. The manufacturer confirms successful testing of the product by affixing to it the **CE** mark.

4 Installation

4.1 Measuring system

A complete measuring system consists of the following components at least:

- The CLS52 inductive conductivity sensor
- A transmitter, e.g. Liquiline CM42

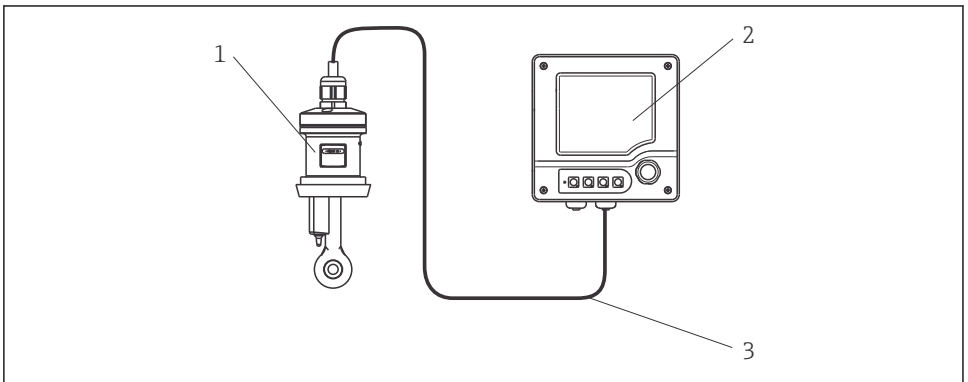

A0028357

 1 *Example of a measuring system*

- 1 *Indumax CLS52*
- 2 *Liquiline CM42 transmitter*
- 3 *Fixed cable (on the sensor)*

4.2 Design

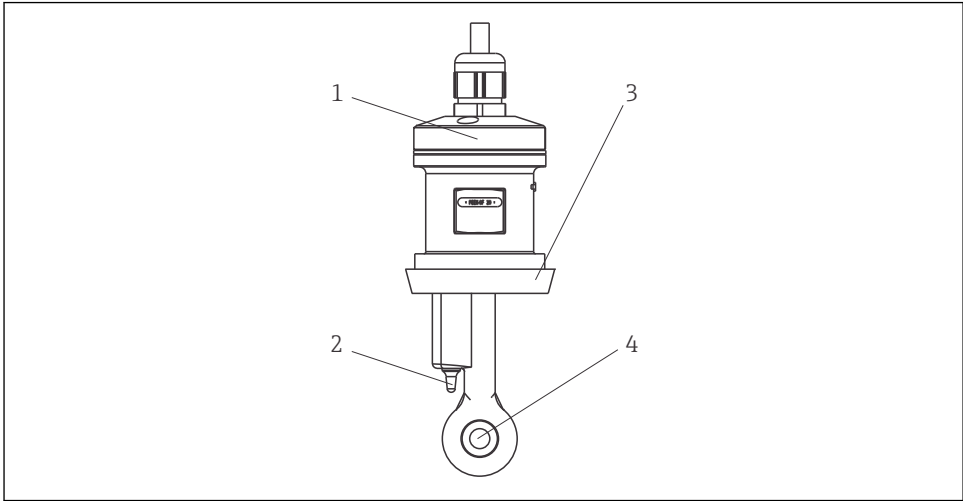

A0028354

2 Indumax CLS52

- 1 Housing
- 2 Temperature sensor
- 3 Process connection
- 4 Flow opening

4.3 Installation conditions

4.3.1 Orientation

The medium must flow through the conical measuring channel in the direction indicated.

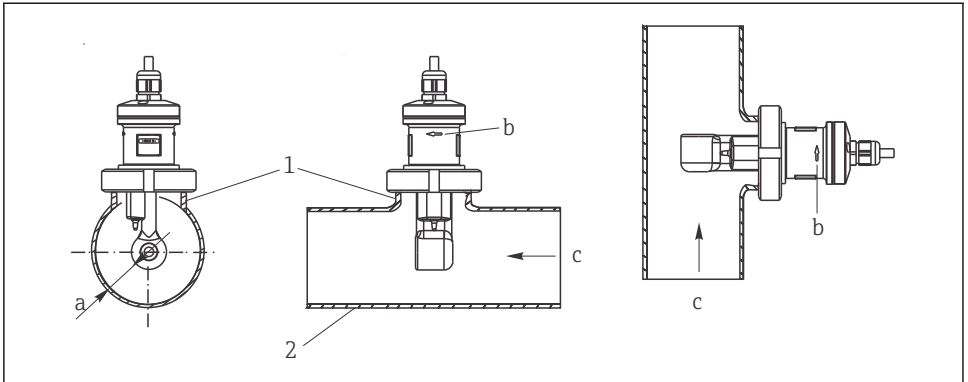

A0028424

▣ 3 Installation of CLS52 in pipes with horizontal flow (center) and vertical flow (right)

- a Sensor distance from wall
- b Indicator arrow for flow direction
- c Direction of flow
- 1 Welding socket
- 2 Pipe

4.3.2 Installation factor

The ionic current in the liquid is affected by the walls in confined installation conditions. This effect is compensated by what is referred to as the installation factor. The installation factor can be entered in the transmitter for the measurement or the cell constant is corrected by multiplying by the installation factor.

The value of the installation factor depends on the diameter and the conductivity of the pipe nozzle as well as the distance a between the sensor and the wall.

The installation factor ($f = 1.0$) can be disregarded if the distance to the wall is sufficient ($a > 15$ mm, from DN 65).

If the distance to the wall is smaller, the installation factor increases for electrically insulating pipes ($f > 1$), and decreases for electrically conductive pipes ($f < 1$).

It can be measured using calibration solutions, or a close approximation can be determined from the adjacent diagram.

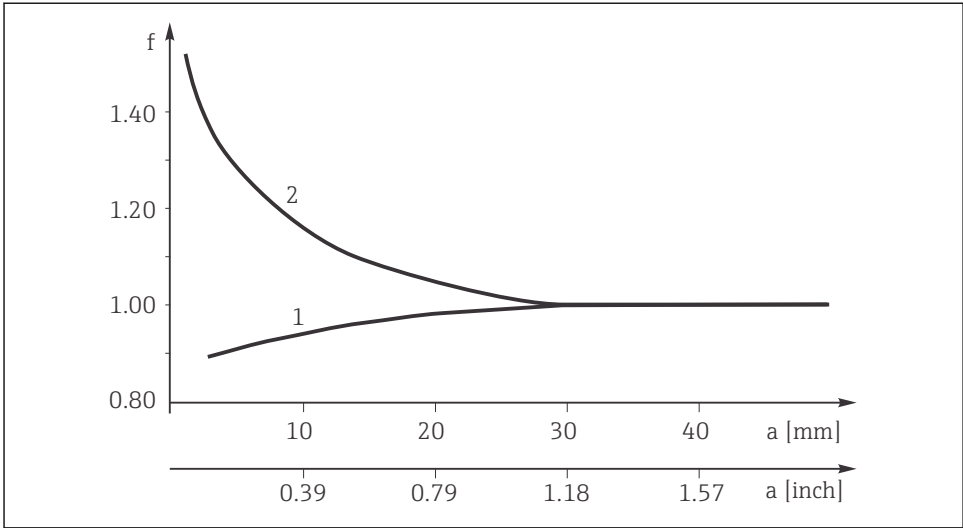

A0028359

4 Relationship between installation factor f and wall distance a

- 1 Conductive pipe
- 2 Insulating pipe

4.3.3 Air set

To compensate residual coupling in the cable and between the two sensor coils, zero adjustment in air ("air set") must be performed before installing the sensor. Follow the instructions provided in the Operating Instructions of the transmitter used.

4.4 Dimensions

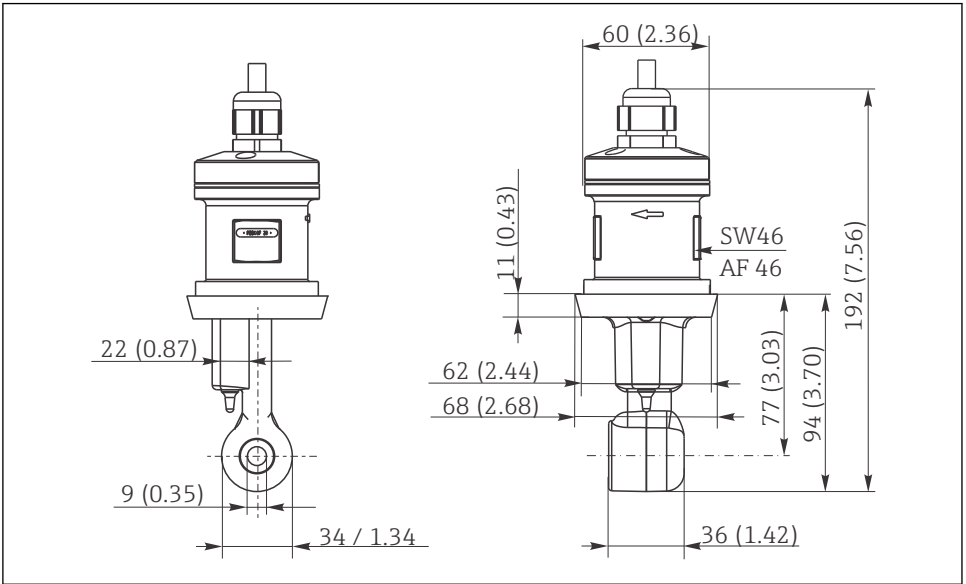

A0028353

5 Dimensions of CLS52 in mm(inch)

4.4.1 Process connections

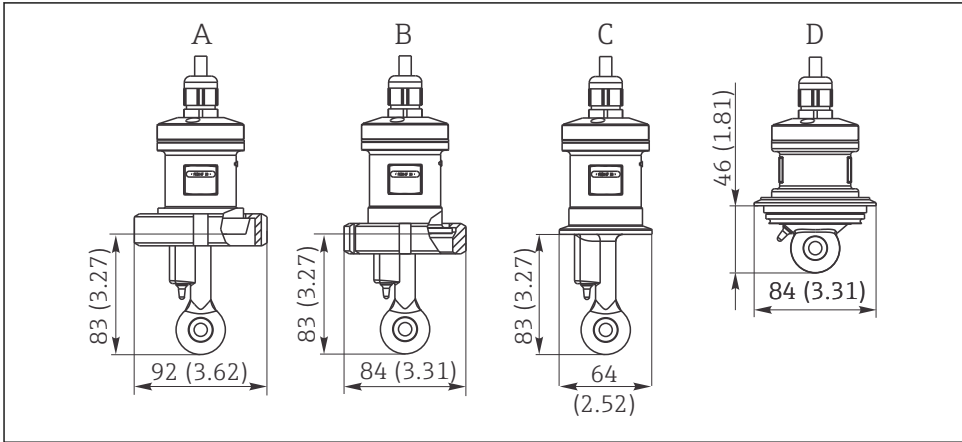

A0028358

6 Process connections for CLS52, dimensions in mm(inch)

- A Sanitary connection DN 50 (DIN 11851)
- B SMS 2"
- C Clamp 2" (ISO 2852)
- D Varivent N DN 40 to DN 125

Clamp connection

Both sheet-metal brackets and solid brackets can be used to secure the sensor. Sheet-metal brackets have a lower dimensional stability, uneven bearing surfaces causing point loads, and sometimes sharp edges that can damage the clamp.

We urgently recommend you only use solid brackets due to their higher dimensional stability. Solid brackets can be used over the entire specified pressure/temperature range.

4.5 Post-installation check

Put the sensor into operation only if you can answer "yes" to the following questions:

- Are the sensor and cable undamaged?
- Is the orientation correct?
- Has the sensor been installed in the process connection, and does not suspend freely from the cable?

5 Electrical connection

⚠ WARNING

Device is live

Incorrect connection may result in injury or death

- ▶ The electrical connection may be performed only by an electrical technician.
- ▶ The electrical technician must have read and understood these Operating Instructions and must follow the instructions contained therein.
- ▶ **Prior** to commencing connection work, ensure that no voltage is present on any cable.

5.1 Connecting to the transmitter

The sensor is supplied with a fixed cable. The wiring diagram is provided in the Operating Instructions of the transmitter used.

Connection via a VBM junction box is necessary for a cable connection. The extension to the transmitter is via the CLK6 cable.

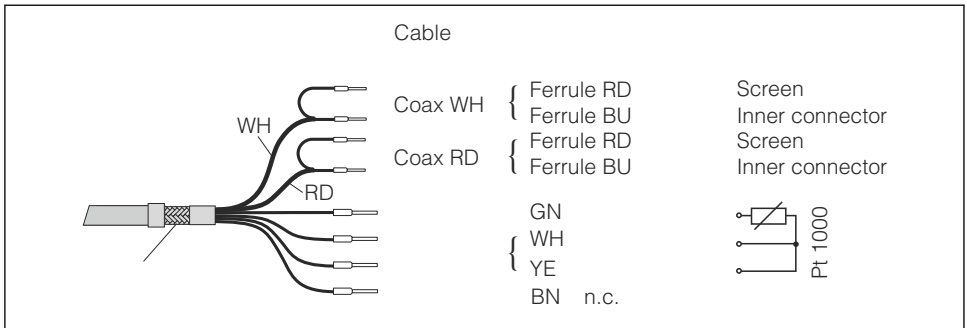

A0005433-EN

7 Fixed cable / measuring cable CLK6

Cable length: maximum 55 m (180 ft) total length

5.2 Ensuring the degree of protection

Only the mechanical and electrical connections which are described in these instructions and which are necessary for the required, designated use, may be carried out on the device delivered.

- ▶ Exercise care when carrying out the work.

Otherwise, the individual types of protection (Ingress Protection (IP), electrical safety, EMC interference immunity) agreed for this product can no longer be guaranteed due, for example, to covers being left off or cable (ends) which are loose or insufficiently secured.

5.3 Post-connection check

Device condition and specifications	Notes
Are the outside of the sensor, assembly, cable undamaged?	Visual inspection
Electrical connection	Notes
Are the installed cables strain-relieved and not twisted?	
Is a sufficient length of the cable cores stripped, and is it positioned in the terminal correctly?	Check the fit (by pulling gently)
Are all the screws terminals properly tightened?	Tighten
Are all cable entries mounted, tightened and leak-tight?	For lateral cable entries, make sure the cables loop downwards to allow water to drip off
Are all cable entries installed downwards or mounted laterally?	

6 Maintenance

CAUTION

Corrosive chemicals

Danger of chemical burns to the eyes and skin. Danger of damage to clothing and equipment

- ▶ It is absolutely essential to protect the eyes and hands properly when working with acids, bases and organic solvents!
- ▶ Wear protective goggles and safety gloves.
- ▶ Clean away splashes on clothes and other objects to prevent any damage.
- ▶ Pay particular attention to the information provided in the safety data sheets for the chemicals used.

As there is no galvanic contact with the medium, inductive sensors are considerably less sensitive to dirt and fouling than conventional conductive sensors.

However, dirt can clog the measuring channel which, in turn, can alter the cell constant. In such cases, an inductive sensor also needs to be cleaned.

Clean away fouling on the sensor as follows depending on the type of fouling:

- Oily and greasy films:
Clean with grease remover, e.g. alcohol, acetone, possibly hot water and dishwashing detergent.
- Lime and metal hydroxide buildup:
Dissolve buildup with diluted hydrochloric acid (3 %) and then rinse thoroughly with plenty of clear water.
- Sulfidic buildup (from flue gas desulfurization or sewage treatment plants):
Use a mixture of hydrochloric acid (3 %) and thiocarbamide (commercially available) and then rinse thoroughly with plenty of clear water.
- Buildup containing proteins (e.g. food industry):
Use a mixture of hydrochloric acid (0.5 %) and pepsin (commercially available) and then rinse thoroughly with plenty of clear water.

7 Repairs

7.1 Return

The product must be returned if repairs or a factory calibration are required, or if the wrong product was ordered or delivered. As an ISO-certified company and also due to legal regulations, Endress+Hauser is obliged to follow certain procedures when handling any returned products that have been in contact with medium.

To ensure swift, safe and professional device returns, please read the return procedures and conditions at www.endress.com/support/return-material.

7.2 Disposal

The device contains electronic components and must therefore be disposed of in accordance with regulations on the disposal of electronic waste.

Observe the local regulations.

8 Accessories

8.1 Cable extension

8.1.1 Measuring cable

Measuring cable CLK6

- Extension cable for inductive conductivity sensors, for extension via VBM junction box
- Sold by the meter, order number: 71183688

8.1.2 Junction box

VBM

- Junction box for cable extension
- 10 terminal strips
- Cable entries: 2 x Pg 13.5 or 2 x NPT ½"
- Material: aluminum
- Degree of protection: IP 65
- Order numbers
 - Cable entries Pg 13.5 : 50003987
 - Cable entries NPT ½": 51500177

Desiccant pouch

- Desiccant pouch with color indicator for VBM junction box
- Order No. 50000671

8.2 Calibration solutions

Conductivity calibration solutions CLY11

Precision solutions referenced to SRM (Standard Reference Material) by NIST for qualified calibration of conductivity measuring systems in accordance with ISO 9000

- CLY11-B, 149.6 $\mu\text{S}/\text{cm}$ (reference temperature 25 °C (77 °F)), 500 ml (16.9 fl.oz)
Order No. 50081903
- CLY11-C, 1.406 mS/cm (reference temperature 25 °C (77 °F)), 500 ml (16.9 fl.oz)
Order No. 50081904
- CLY11-D, 12.64 mS/cm (reference temperature 25 °C (77 °F)), 500 ml (16.9 fl.oz)
Order No. 50081905
- CLY11-E, 107.00 mS/cm (reference temperature 25 °C (77 °F)), 500 ml (16.9 fl.oz)
Order No. 50081906



Technical Information TI00162C

9 Technical data

9.1 Input

9.1.1 Measured values

- Conductivity
- Temperature

9.1.2 Measuring range

Conductivity	Recommended range: 100 $\mu\text{S}/\text{cm}$ to 2000 mS/cm (uncompensated)
Temperature	-5 to +140 °C (+23 to 284 °F)

9.1.3 Cell constant

$k = 5.9 \text{ cm}^{-1}$

9.1.4 Temperature measurement

Pt1000 (according to DIN EN 60751)

9.2 Performance characteristics

9.2.1 Temperature response time

$t_{90} < 5 \text{ s}$

9.2.2 Maximum measured error

-5 to +100 °C (+23 to 212 °F):	$\pm(10 \mu\text{S}/\text{cm} + 0.5 \% \text{ of reading})$
> 100 °C (212 °F):	$\pm(30 \mu\text{S}/\text{cm} + 0.5 \% \text{ of reading})$

9.3 Environment

9.3.1 Ambient temperature range

-10 to +70 °C (+10 to +160 °F)

9.3.2 Storage temperature

-25 to +80 °C (-13 to +176 °F)

9.3.3 Relative humidity

5 to 95 %

9.3.4 Degree of protection

IP 67 / NEMA 6

9.4 Process

9.4.1 Process temperature

-5 to +125 °C (+21 to +257 °F)

9.4.2 Sterilization

140 °C (284 °F) / 5 bar (72 psi) absolute, (max. 30. min.)

9.4.3 Process pressure (absolute)

17 bar (264.5 psi) up to 90 °C (194 °F)

9.4.4 Temperature/pressure ratings

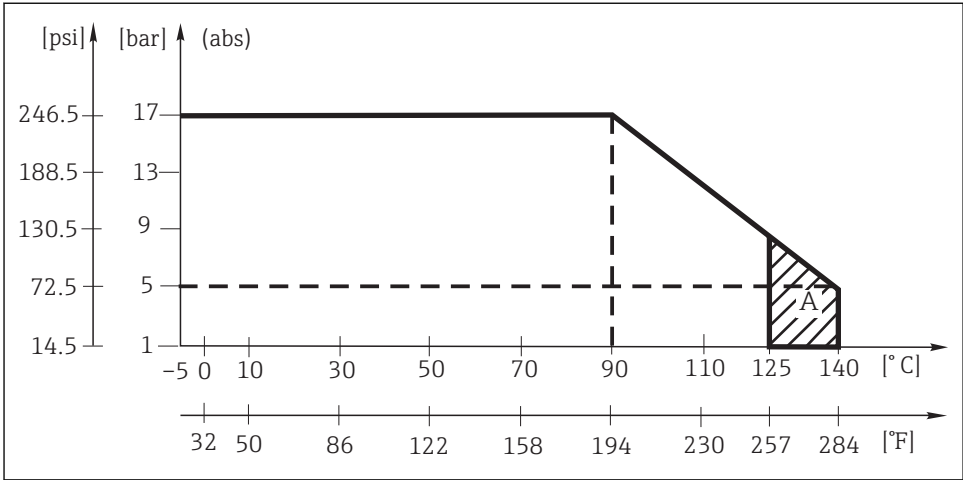

A0028355

8 A = Temporarily for sterilization (max. 30 min.)

9.5 Mechanical construction

9.5.1 Dimensions

→ Section "Installation"

9.5.2 Weight

0.4 to 0.8 kg (0.88 to 1.76 lb.) depending on version

9.5.3 Materials

Sensor:	PEEK-GF20
Varivent flange:	
Flange:	Stainless steel 1.4435 (AISI 316L)
Seal:	EPDM
Metal temperature sensor socket:	
Socket:	Stainless steel 1.4435 (AISI 316L)
Seal:	Chemraz

9.5.4 Chemical resistance

Medium	Concentration	PEEK	1.4435	CHEMRAZ	EPDM
Sodium hydroxide solution NaOH	0 to 10 %	20 to 100 °C (68 to 212 °F)	20 to 90 °C (68 to 194 °F)	20 to 100 °C (68 to 212 °F)	20 to 100 °C (68 to 212 °F)
	0 to 50 %	20 to 100 °C (68 to 212 °F)	20 to 90 °C (68 to 194 °F)	20 to 100 °C (68 to 212 °F)	20 to 60 °C (68 to 140 °F)
Nitric acid HNO ₃	0 to 10 %	20 to 100 °C (68 to 212 °F)	20 to 100 °C (68 to 212 °F)	20 to 100 °C ¹⁾ (68 to 212 °F) ¹⁾	20 °C (68 °F)
	0 to 25 %	20 to 40 °C (68 to 104 °F)	20 to 100 °C (68 to 212 °F)	20 to 100 °C ¹⁾ (68 to 212 °F) ¹⁾	Cannot be used
Phosphoric acid H ₃ PO ₄	0 to 10 %	20 to 100 °C (68 to 212 °F)	20 to 100 °C (68 to 212 °F)	20 to 100 °C (68 to 212 °F)	20 to 80 °C (68 to 176 °F)
	0 to 30 %	20 to 100 °C (68 to 212 °F)	20 to 85 °C (68 to 185 °F)	20 to 100 °C (68 to 212 °F)	20 to 80 °C (68 to 176 °F)
Sulfuric acid H ₂ SO ₄	0 to 2.5 %	20 to 100 °C ¹⁾ (68 to 212 °F) ¹⁾	20 to 70 °C (68 to 158 °F)	20 to 100 °C (68 to 212 °F)	20 to 30 °C (68 to 86 °F)
	0 to 30 %	20 to 100 °C ¹⁾ (68 to 212 °F) ¹⁾	Cannot be used	20 to 100 °C (68 to 212 °F)	20 to 30 °C (68 to 86 °F)

1) Slight corrosion possible

Index

Symbols

€ mark 9

A

Accessories 17
Air set 12
Ambient temperature range 19
Approvals 9

C

Calibration solutions 18
Cell constant 18
Certificates 9
Chemical resistance 21

D

Degree of protection 19
Design 10
Designated use 6
Dimensions 13
Disposal 17

E

Electrical connection 15
Ensuring the degree of protection 15
Environment 19

I

Incoming acceptance 7
Input 18
Installation 9
Installation conditions 10
Installation factor 11
Interpreting the order code 8

J

Junction box 15, 17

M

Maintenance 16
Manufacturer's address 8
Materials 20
Maximum measured error 19
Measured values 18
Measuring cable 17
Measuring range 18

Measuring system 9
Mechanical construction 20

N

Nameplate 8

O

Occupational safety 6
Operational safety 7
Orientation 10

P

Performance characteristics 18
Post-connection check 16
Post-installation check 14
Process 19
Process connections 14
Process pressure 19
Process temperature 19
Product identification 7, 8
Product page 8
Product safety 7

R

Relative humidity 19
Repairs 17
Requirements for the personnel 6
Return 17

S

Safety instructions 6
Scope of delivery 7
Sterilization 19
Storage temperature 19
Symbols 4

T

Technical data 18
Temperature response time 18
Temperature sensor 18
Temperature/pressure ratings 20

U

Use 6

W

Warnings	4
Weight	20
Wiring	15



71377405

www.addresses.endress.com
