

Metering Pumps



EJ Series

The EJ Series provide precise chemical injection at an economical price.

Universal voltage capability enables operation from 100 - 240 VAC in virtually all countries.

The EJ Series are compact, simple to operate and have outputs to 1.3 GPH (4.8 LPH) and a maximum pressure of 175 PSI (1.2 MPa).



Summary of Key Benefits

- **High Speed Performance**
The EJ Series operate at 360 strokes-per-minute, providing high resolution chemical feed and high turndown capability. Most competitive products operate at slower speeds, resulting in slug feeding, accelerated diaphragm wear and poor feed control.
- **Universal Voltage**
The Universal Voltage Function enables the EJ Series to operate at any AC voltage. The EJ Series also conform to global standards.
- **External Control**
The EJ Series have both digital input and Stop/Start inputs built into the pump, enabling either proportional or On/Off control.
- **IP65 Equivalent Protection**
A robust housing protects the pump from normal wear. Mounting the Digital Display and Key Pad control within the drive housing creates a highly water resistant design. A clear cover further protects the pump from liquids.

Iwaki Metering Pump

MODEL EJ-B11VCUR
PRESSURE 150 PSI
CAPACITY 0.6 GPH
STROKE RATE 1-360SPM
VOLTAGE 115 V
CURRENT 0.9 A
FREQUENCY 50/60 Hz
MAX. LIQUID TEMP. 104°F
MFG. No. U061803055

Thermally Protected
Acceptable for indoor use only
Enclosure type 2
Utilisation Intermittent
equipment
Bolton die type 2
Nonsubmersible Pump
Conforms to ANSI/UL Std 778
Certified to
CAN/CSA Std. C22.2 No.108
YEAR 2018



WALCHEM

IWAKI America Inc.

Specifications

Pump

Model		B09*	B11	B16	B21
Max. capacity	GPH (mL/min)	0.3 (19)	0.5 (30)	0.8 (50)	1.3 (80)
Max. discharge pressure	PSI (MPa)	175 (1.2)	150 (1.0)	90 (0.6)	45 (0.3)
Stroke rate	spm	1 to 360			
Power consumption	W	12			
Current (Input)	A	0.8			
Shipping Weight	lbs (kg)	8.0 (3.6)			

- The above information is based on pumping clean water at rated voltage and ambient temperature.
- Flow rates were collected at the maximum discharge pressure and 360spm. Degassing option derates capacity by approximately 20%.
- *B09 size is available in PVC liquid ends only
- Flow rate increases as discharge pressure decreases.
- Allowable ambient temperature: 0 to 104°F (0 to 40°C)
- Allowable liquid temperature: 0 to 104°F (0 to 40°C)
- Allowable power voltage deviation: ±10% of the rated voltage
- Noise level: 65dB at 10 ft. (A scale)
- E90495 (field-wireable connector) or IX0018 (connector with 5 ft. cable) required for Inputs.

Controller

Operation mode	Mode	Manual
		EXT
	Mode selection	Key operation
Stroke rate	Setting range	1 to 360spm
	SPM programming	UP key
STOP function	Input signal	No-voltage contact or open collector ^{Note 1}
EXT mode	Maximum spm	360spm
	Pump behavior	1 shots per signal ^{Note 2}
	Input signal	No-voltage contact or open collector ^{Note 1}
Monitors	LCD	7x3 LCD with three status codes
	LED	Green LEDx1 (blinks at each shot)
Buffer		Non-volatile memory
Power voltage ^{Note 3}		100 to 240VAC 50/60Hz

- The max voltage from the EJ to an external contact is 15V at 3mA. When using a mechanical relay, the minimum load should be 3mA or below.
- When the external pulse signal is over the max spm, the extra pulses are ignored.
- The allowable voltage range is 90 to 264VAC. Outside of this range, failure may result.

Safety Certifications

The EJ series metering pumps* are WQA tested and certified to NSF/ANSI Standard 50 and Standard 61.

* See www.wqa.org for specific chemicals and certification parameters.

The EJ series metering pumps are tested by Intertek to UL and CSA standards.



180606.J June 2019

EJ - B 11 VC □ U R □

- Drive unit symbol**
Average power consumption
B: 12W
- Diaphragm diameter**
*09: 8mm, 11: 10mm
16: 15mm, 21: 20mm
- Wet-end material symbol**
For details, see the Liquid End Materials table.
- Special version**
A: Auto degassing valve
M: Multifunction valve
- Controller function code**
R: External control
- Power code**
U: US 115 VAC plug
2: US 230 VAC plug
- Connection (No Character)**
3/8" OD x 1/4" ID (09-21 sizes)
For other options, consult factory

Dimensions

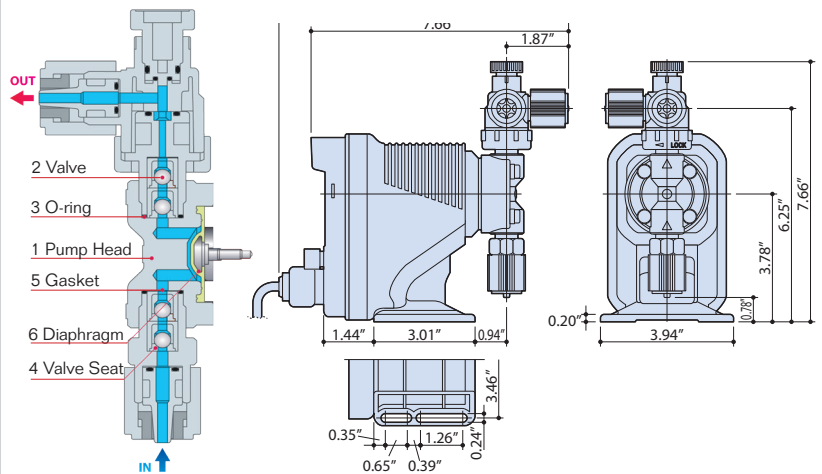

Liquid End Materials

Material	1	2	3	4	5	6
	Pump head	Valve	O-Ring	Valve seat	Gasket	Diaphragm
VC	PVC	CE	FKM	FKM	PTFE	PTFE + EPDM backer
VE	PVC	CE	EPDM	EPDM	PTFE	
VF	PVC	PTFE	EPDM	EPDM	PTFE	
TC	PVDF	CE	FKM	FKM	PTFE	
PC	GFRPP	CE	FKM	FKM	PTFE	
PE	GFRPP	CE	EPDM	EPDM	PTFE	
FC	PVDF	CE	PTFE	PCTFE	PTFE	
TA	PVDF	CE	AFLAS®	PCTFE	PTFE	
PA	GFRPP	CE	AFLAS®	PCTFE	PTFE	
SHN	316SS	316SS	---	316SS	PTFE	

CE	Alumina ceramic	EPDM	Ethylene propylene diene monomer
FKM	Fluoroelastomer	GFRPP	Glass fiber reinforced polypropylene
PTFE	Polytetrafluoroethylene	PVC	Polyvinylchloride (translucent)
PCTFE	Polychlorotrifluoroethylene	PVDF	Polyvinylidene fluoride
AFLAS®	Tetrafluoroethylene-Propylene		



WALCHEM
IWAKI America Inc.

Walchem, Iwaki America Inc.
Five Boynton Road Hopping Brook Park
Holliston, MA 01746 USA
Phone: 508-429-1110 www.walchem.com