

Quick Start Guide

GFK-3268A

Oct 2023

# PACSystems™ IPC 2010

## QUICK START GUIDE



# Contents

Initial Checks .....	1
Front Panel Description .....	2
Power-Input.....	3
Serial Console.....	6
Secure Shell (SSH).....	7
IP-Addresses .....	7
Pre-Installed Software Images .....	8
Ubuntu Server Quick Start.....	9
Default User and Passwords .....	9
Networking Configuration .....	10
Additional network configuration.....	11
PACEdge Quick Start .....	12
Getting Started.....	13
Initial Login.....	13
Additional Information .....	17
WiFi/Cellular Extension.....	17
WiFi/Cellular Module with PACEdge .....	17
Overtemperature Alarm .....	17
LED Control .....	18
Accessing the Boot Loader .....	18
Additional Information .....	19
General Contact Information.....	19

## Initial Checks

Upon receiving your equipment, carefully inspect all shipping containers for damage. If any part of the system is damaged, notify the carrier immediately. The damaged shipping container should be saved as evidence for inspection by the carrier.

As the consignee, it is your responsibility to register a claim with the carrier for damage incurred during shipment. Emerson will fully cooperate with you, however, should such action be necessary.

After unpacking the equipment, record all serial numbers. Serial numbers are required if you should need to contact Customer Care during the warranty period. All shipping containers and all packing material should be saved should it be necessary to transport or ship any part of the system.

Verify that all components of the system have been received and that they agree with your order. If the system received does not agree with your order, contact Customer Care.

# Front Panel Description

Figure 1: Overview



Number	Description
1	Power & Temperature LED
2	µSD Card slot
3	USB-C port
4	Serial port
5	USB ports
6	Ethernet ports
7	Power Connector

# Power-Input

To power the system, a voltage of 24 V DC must be supplied to the power connector. The IPC 2010 power supply must meet the requirements for SELV (safety extra-low voltage)/LPS (limited power source) or ES1/PS2 appropriately rated for the ambient and altitude of the application. There are no buttons for power or resetting, as the system will start automatically once power is applied. The Power LED (1) will light up green to indicate that the system is now powered on.

The specific plug required is a Phoenix Contact with the part number 1748367, and users must use the same connector type

---

**Figure 2: Power Input**

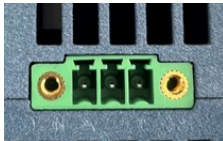

Signal Name	Pin (left to right)
FGND	1
Power – 24VDC (10-30VDC)	2
Power + 24VDC (10-30VDC)	3

## CAUTION

Equipment is intended for installation in Restricted Access Area.

Les matériels sont destinés à être installés dans des  
EMPLACEMENTS À ACCÈS RESTREINT.

---

## Battery

The IPC 2010 contains a CR2032 lithium coin battery. It is a industrial CR2032 (-40°C to 125°C) battery and is accessible on the right side of the IPC 2010. Depending on the operating hours and temperature, the estimated battery life is 2 to 10 years. Battery current is not used when the IPC 2010 is supplied with 24V.

## Battery Maintenance

To replace the battery, pull the battery holder (on the right side of the system) out of the system, replace the battery and insert the battery holder back into the system.

**Figure 3: Battery Removal**

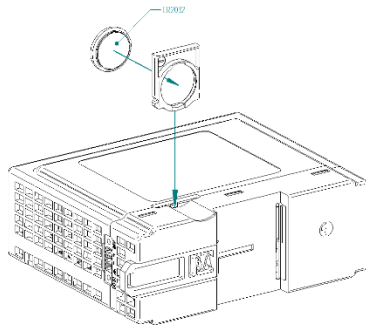

### **⚠ CAUTION**

- Only replace with CR2032 battery. Batteries may explode if mistreated. Do not charge, disassemble, or incinerate.
- Remplacer uniquement par une pile CR2032. Les piles peuvent exploser si elles sont maltraitées. Ne pas charger, démonter ou incinérer.

## Serial Console

To gain access to the system, utilize the serial console port (4) by connecting it to the host PC's RS232 interface using a null modem cable. Once connected, the host can establish a connection by running a terminal emulator such as HyperTerminal or minicom. The default serial port parameters are **115200, 8N1**

The connector is RJ-45 style with pinout as defined in EIA/TIA-561, so that off-the-shelf adapters to DB9 or USB can be used.

The pinout for RJ-45 (8P8C) connector is defined as follows:

Signal	RJ-45 Pin
GND	4
RxD	5
TxD	6

Once a serial connection is established, it can be used to determine an IP address that was assigned by DHCP server, using command: **ip addr**

## Secure Shell (SSH)

To establish a connection with the system, Ethernet can be used instead of the serial console. The system has an SSH server running on port 22, and the default IP address settings are described below.

To connect to the system, use Putty on a Windows host or the default SSH tools on Linux.

The login credentials will vary depending on the pre-installed software \*Ubuntu Linux or PACEdge), so it is advised to refer to the sections below for specific details.

## IP-Addresses

On preinstalled systems the second ethernet interface (Port 2) is configured to use the static IP-Address: **192.168.3.100** and DHCP as well. Therefore (if the second ethernet interface is connected to a DHCP server) two IP-Addresses are usable on this interface (IP-Address provided by DHCP server and static IP-Address 192.168.3.100).

### CAUTION

MULTIPLE DEVICES WITH THE SAME IP ADDRESS ON THE SAME NETWORK CAN LEAD TO ADDRESS CONFLICTS WITH UNPREDICTABLE BEHAVIOR.

If you are using several microIPC devices in the same network, it is **strongly recommended** to change the static IP Address.

# Pre-Installed Software Images

IPC 2010 comes with two pre-installed software options:

- Ubuntu Server 20.04.05 LTS
- PACEdge v2.3.0 (based on Ubuntu 20.04 Server)

Depending on pre-installed software login credentials and some of the configuration tasks are different. Sections bellow will guide through the getting started process for each of these software options.

# Ubuntu Server Quick Start

Ubuntu Server 20.04.05 LTS software package provides a basic Linux operating system environment on IPC 2010. Software installation contains only basic software packages, but user can easily install additional packages by using **apt** command.

## Default User and Passwords

Default Username	<b>ubuntu</b>
Default Password	<b>ubuntu</b>

**Note:** This user also has sudo permissions to be able to execute privileged operations and to install additional software packages using **apt** command.

## Networking Configuration

In Ubuntu Server, the interface **Port 1** is named **lan1**, the interface **Port 2** is named **lan0**.

### CAUTION

MULTIPLE DEVICES WITH THE SAME IP ADDRESS ON THE SAME NETWORK CAN LEAD TO ADDRESS CONFLICTS WITH UNPREDICTABLE BEHAVIOR.

If you are using several microIPC devices in the same network, it is **strongly recommended** to change the static IP Address.

---

The static IP-Address can be configured in the following files:

Interface 1	<i>/etc/netplan/20-eth1.yaml</i>
Interface 2	<i>/etc/netplan/10-eth0.yaml</i>

## Additional network configuration

If the system obtains an IP address via DHCP, the server may supply additional information like DNS server addresses or the default gateway to configure the client system.

If this is not the case, or when using manual IP configuration, some additional settings must be made to obtain full network functionality.

Setting the default gateway:

```
ip route set default via <address>
```

Setting a DNS server:

```
resolvectl dns lan0 <server address>
```

Permanent network configuration is done via netplan and its configuration files in `/etc/netplan/`. Activate the new configuration after making changes with:

```
netplan apply
```

# PACEdge Quick Start

PACEdge version 2.3.0 software package is a data acquisition, analytics and visualization platform based on Ubuntu 20.04 Linux. Following sections will describe steps to get started. For additional information please consult PACEdge v2.3.0 User Manual.

On IPC 2010 PACEdge operates in a headless mode with the user accessing it remotely via Ethernet using a web interface.

---

**Figure 4: Use Case Model**

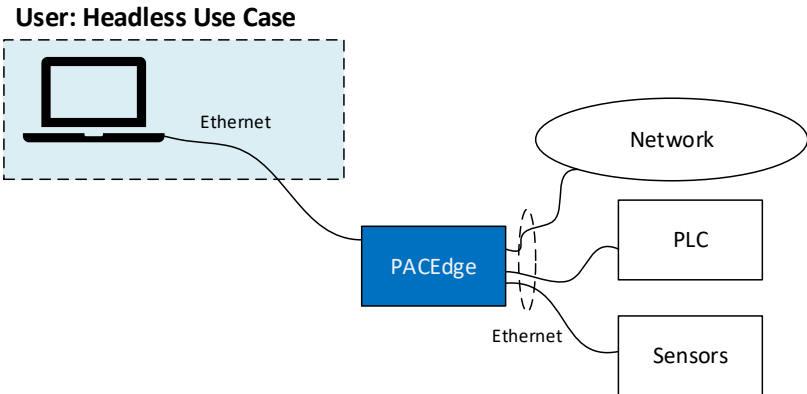

## Getting Started

1. Connect the Ethernet cable to the Ethernet port labeled Port2.
2. Setup the User PC Ethernet port IP address to be statically assigned as follows:

**Pv4 Static IP: 192.168.3.10**  
(or similar in the same subnet)

**a. Netmask: 255.255.255.0**

1. Power up the IPC (please consult initial startup section for details) and wait until it boots.
2. Open the browser of your choice and type in **192.168.3.100** in the address bar.

**Note:** All Ethernet ports are also configured to get IP addresses assigned by the DHCP server. This dynamically assigned IP address can also be used to access PACEdge.

## Initial Login

Upon connecting to PACEdge for the first time, a warning message may display due to the self-signed certificate on the device. The message will state that the identity of the device could not be confirmed. To proceed please click on **Advanced** and **Accept**.

Please read and accept the Emerson End User License Agreement (EULA).

Once EULA has been accepted you will be redirected to the Password Management screen. PACEdge software consists of multiple software tools and applications, each having its user management and password settings. To simplify the process, PACEdge comes with pre-configured users: *admin*, *developer*, *service*, and *operators*, each having its own password. Use the Password Management screen to change passwords in two steps: 1) for all PACEdge Applications, 2) for Cockpit/Linux (Figure 5). When changing the passwords, follow instructions on the screen and consult help information accessible via question mark button in the upper right corner.

**Note:** For cybersecurity reasons and for proper user account setup, the user **must** change the default passwords at the first login.

---

### **Important**

Please consult the PACEdge Secure Deployment Guide (GFK-3197) for recommended password changes and other cybersecurity-relevant settings

---

**Figure 5: Password Management Screen (top portion: PACEdge Applications, bottom portion: Cockpit/Linux)**

EMERSON | Emerson PACEdge

Services

### Password Management

#### Manage PACEdge Application Passwords

Admin password  Admin Credentials

Login Name	Action	Password Field
admin	<a href="#">Please change Password</a>	<input type="password"/>
developer	<a href="#">Please change Password</a>	<input type="password"/>
service	<a href="#">Please change Password</a>	<input type="password"/>
operators	<a href="#">Please change Password</a>	<input type="password"/>
admin@edgestack.com (used in Movicon Project Deploy)	<a href="#">Please change Password</a>	<input type="password"/>

#### User Rights Overview

#### Manage Cockpit/Linux Passwords

Cockpit/Linux Password Management:  Cockpit

PACEdge | Version: V2.2.0 | Headline | 000 Info

Once the passwords have been changed, click on the Emerson logo in the upper-left corner. The logo is a shortcut to the PACEdge Landing Page, which has further shortcuts to Node-RED, Grafana, Cockpit, Portainer, and other applications. The user can return to the Password Management screen from the PACEdge landing page by clicking **Password Management** in the Settings drop-down list on the right side.

**Figure 6: PACEdge Landing Page**

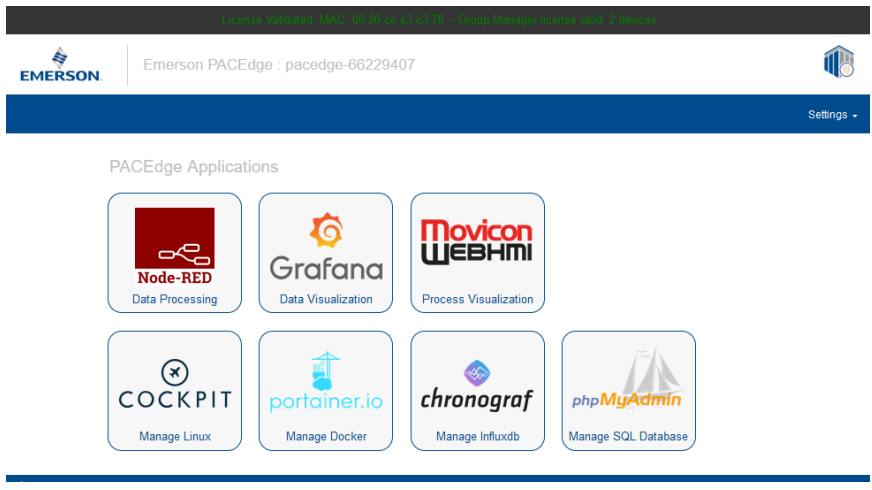

To explore PACEdge, click on Node-RED and log in with:

- **user:** admin
- **password:** edgestack (or the password that was set on the Password Services page)

Start exploring example flows or create your own flows. Consult the PACEdge User Manual (GFK-3178) for example details.

**Important:** Please consult the PACEdge Secure Deployment Guide (GFK-3197) for recommended password changes and other cybersecurity relevant settings.

## Additional Information

### Overtemperature Alarm

To protect the system from damage and to avoid unpredictable behavior, the device will shut down when a temperature limit is reached (actual limit is depending on the system variant).

When this limit is reached, the system will shut down and the Temperature LED (2) will light up in red.

The system will re-start automatically after the temperature has fallen below the threshold hysteresis.

## LED Control

If a user needs to control LED behavior directly, this can be achieved in Linux using the pseudo-files located in

*/sys/class/leds/*

## Accessing the Boot Loader

The boot loader of IPC 2010 is configured to start the installed Linux O/S automatically without user interaction.

If it is necessary to access the boot loader settings or change the boot process, a serial connection cable as described above is required to access the U-boot console.

More information about the boot loader and its functionality can be found in the document 'CPU1v2 U-boot Manual', which is available from Emerson.

# Additional Information

## General Contact Information

### Website

<http://www.emerson.com/industrial-automation-controls/>

### Technical Support

<http://www.emerson.com/industrial-automation-controls/support>

All Rights Reserved.

We reserve the right to modify or improve the designs or specifications of the products mentioned in this manual at any time without notice. Emerson does not assume responsibility for the selection, use or maintenance of any product. Responsibility for proper selection, use and maintenance of any Emerson product remains solely with the purchaser.

©2023 Emerson Electric Co.

