

# Technical Information

## Prosonic S

### FDU90/91/91F/92/93/95

Ultrasonic measurement  
Time-of-Flight



## Ultrasonic sensors for level and flow measurement for connection to FMU9x

### Field of application

- Continuous, non-contact level measurement of fluids and bulk material in silos, on belts, stockpiles and in crushers
- Flow measurement in open channels and at weirs
- Maximum measuring range
  - FDU90: 3 m (9.8 ft) in fluids  
1.2 m (3.9 ft) in bulk materials
  - FDU91/FDU91F: 10 m (33 ft) in fluids  
5 m (16 ft) in bulk materials
  - FDU92: 20 m (66 ft) in fluids  
10 m (33 ft) in bulk materials
  - FDU93: 25 m (82 ft) in fluids  
15 m (49 ft) in bulk materials
  - FDU95: 45 m (148 ft) in bulk materials
- International explosion protection certificates





### Benefits



- Integrated temperature sensor for Time-of-Flight correction. Accurate measurements are possible, even if temperature changes are present
- Hermetically welded PVDF sensors FDU91/92 for highest chemical resistance
- Suited for rough ambient conditions thanks to separate installation from the transmitter (up to 300 m (984 ft))
- Reduced build-up formation because of the self-cleaning effect
- Weather resistant and flood-proof (IP68)
- Dust-Ex and Gas-Ex certificates available

# Table of Contents

<b>Safety symbols</b> .....	<b>3</b>	<b>Certificates and Approvals</b> .....	<b>21</b>
<b>Function and system design</b> .....	<b>3</b>	CE mark .....	21
Measuring principle .....	3	Ex approval .....	21
Time-of-flight correction .....	4	External standards and directives .....	21
Blocking distance .....	4	<b>Ordering information</b> .....	<b>21</b>
Transmitter .....	4	Ordering information .....	21
<b>Input</b> .....	<b>5</b>	5-point linearity protocol .....	22
Measuring range .....	5	Scope of delivery .....	22
Operating frequency .....	6	<b>Accessories</b> .....	<b>23</b>
<b>Output</b> .....	<b>6</b>	Extension cable for sensors .....	23
Signal transmission .....	6	Protective cover for FDU90 and FDU91 .....	23
<b>Power supply</b> .....	<b>6</b>	Screw in flange FAX50 .....	24
Power supply .....	6	Flooding protection tube for FDU90 .....	25
Sensor heater (for FDU91) .....	6	Cantilever with mounting frame or wall bracket .....	26
<b>Electrical connection</b> .....	<b>7</b>	Mounting bracket for ceiling mounting .....	28
Connection diagram .....	7	Alignment unit FAU40 .....	29
Connection hints .....	8	Power supply RNB130 for the FDU90/FDU91 sensor heater .....	30
Extension cables for the sensors .....	8	IP66 protective housing for the power supply RNB130 .....	30
Shortening the sensor cable .....	9	<b>Documentation</b> .....	<b>30</b>
<b>Installation</b> .....	<b>10</b>	Technical Information .....	30
Installation options (Examples) .....	10	Operating instructions (for transmitter FMU90) .....	30
Installation conditions for level measurements .....	11	Description of Instrument Functions (for transmitter FMU90) .....	31
Installation conditions for flow measurements .....	12	Safety Instructions .....	31
Flush mounting with slip-on flange FAU80 .....	13		
Nozzle installation .....	14		
Ultrasound guide pipe .....	15		
<b>Environment</b> .....	<b>16</b>		
Ingress protection .....	16		
Vibration resistance .....	16		
Storage temperature .....	16		
Thermal shock resistance .....	16		
Electromagnetic compatibility .....	16		
Explosion hazardous area .....	16		
<b>Process</b> .....	<b>16</b>		
Process temperature, Process pressure .....	16		
<b>Mechanical construction</b> .....	<b>17</b>		
Counter nut G 1" .....	17		
Dimensions FDU90 .....	17		
Dimensions FDU91 .....	17		
Dimensions FDU91F .....	18		
Dimensions FDU92 .....	18		
Dimensions FDU93 .....	18		
Dimensions FDU95 .....	19		
Weight .....	19		
Materials .....	19		
Connecting cable .....	20		

## Safety symbols

Symbol	Meaning
 A0011189-DE	<b>DANGER!</b> This symbol alerts you to a dangerous situation. Failure to avoid this situation will result in serious or fatal injury.
 A0011190-DE	<b>WARNING!</b> This symbol alerts you to a dangerous situation. Failure to avoid this situation can result in serious or fatal injury.
 A0011191-DE	<b>CAUTION!</b> This symbol alerts you to a dangerous situation. Failure to avoid this situation can result in minor or medium injury.
 A0011192-DE	<b>NOTICE!</b> This symbol contains information on procedures and other facts which do not result in personal injury.

Explosion protection	Meaning
	<b>Device certified for use in explosion hazardous area</b> If the device has this symbol embossed on its name plate it can be installed in an explosion hazardous area
	<b>Explosion hazardous area</b> Symbol used in drawings to indicate explosion hazardous areas. Devices located in and wiring entering areas with the designation "explosion hazardous areas" must conform with the stated type of protection.
	<b>Safe area (non-explosion hazardous area)</b> Symbol used in drawings to indicate, if necessary, non-explosion hazardous areas. Devices located in safe areas still require a certificate if their outputs run into explosion hazardous areas

## Function and system design

### Measuring principle

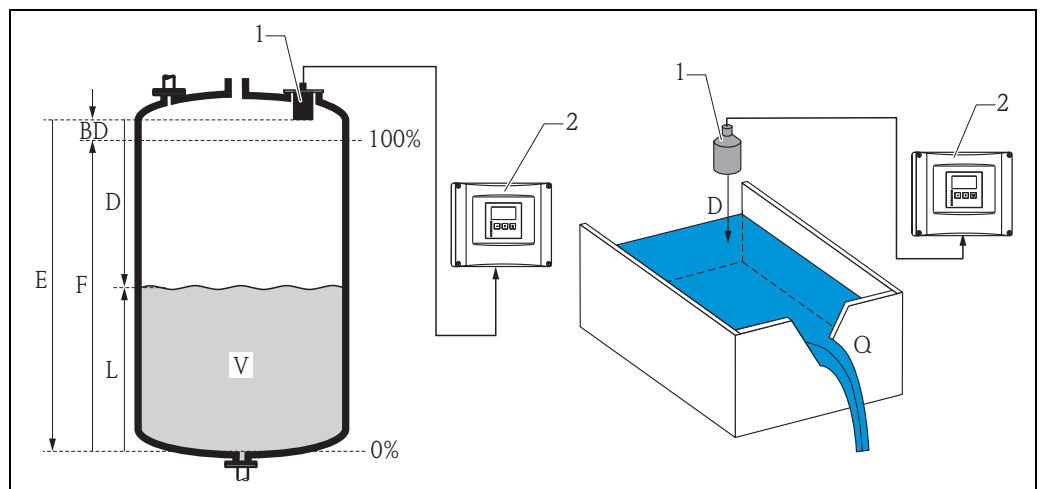

1 FDU9x

2 Prosonic S FMU90

**BD:** blocking distance, **D:** distance from sensor membrane to fluid surface, **E:** empty distance **F:** span (full distance), **L:** level, **V:** volume (or mass), **Q:** flow

L00-FMU90xxx-15-00-08-xx-900

Sensor	BD	Maximum range fluids	Maximum range bulk materials
FDU90	0.07 (0.2)	3 (9.8)	1.2 (3.9)
FDU91 (F)	0.3 (1.0)	10 (33)	5 (16)
FDU92	0.4 (1.3)	20 (66)	10 (33)
FDU93	0.6 (2.0)	25 (82)	15 (49)
FDU95 (low temperature version)	0.7 (2.3)	–	45 (148)
FDU95 (high temperature version)	0.9	–	45 (148)

m (ft)

**Time-of-flight method**

The sensor transmits ultrasonic pulses in the direction of the product surface. There, they are reflected back and received by the sensor. The transmitter Prosonic S measures the time *t* between pulse transmission and reception. From *t* (and the velocity of sound *c*) it calculates the distance *D* from the reference point (see the figure → 4) to the product surface:

$$D = c \cdot t / 2$$

From *D* results the desired measuring value:

- Level *L*
- Volume *V*
- Flow *Q* across measuring weirs or open channels

**Time-of-flight correction**

In order to compensate for temperature dependent time-of-flight changes, a temperature sensor (NTC) is integrated in the ultrasonic sensors.

**Blocking distance**

The level *L* may not extend into the blocking distance *BD*. Level echoes within the blocking distance can not be evaluated due to the transient characteristics of the sensor and thus a reliable measurement is not possible. The blocking distance *BD* is dependent on the type of sensor:

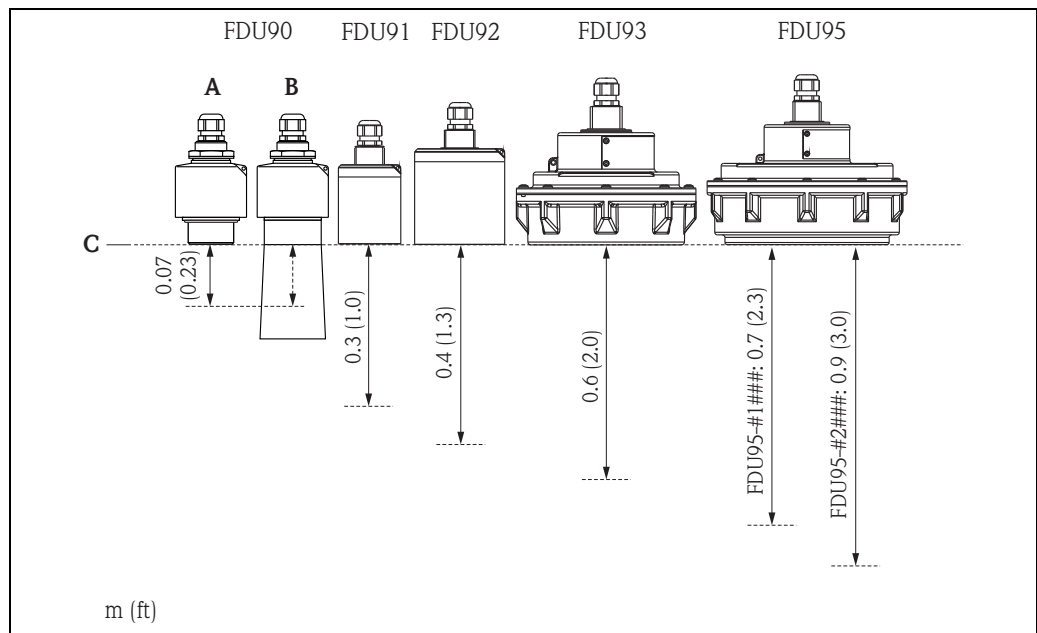

A: Without flooding protection tube, B: With flooding protection tube, C: Reference point of the sensor

**Transmitter**

The sensors can be connected to the transmitter FMU90 and FMU95. The transmitter recognizes the type of sensor automatically.

# Input

## Measuring range

The effective range of the sensors is dependent on the operating conditions. To estimate the range, proceed as follows (see also the example):

1. Determine which of the influences shown in the following table are appropriate for your process.
2. Add the corresponding attenuation values.
3. From the total attenuation, use the diagram to calculate the range.

Fluid surface	Attenuation
calm	0 dB
waves	5 to 10 dB
strong turbulence (e.g. stirrers)	10 to 20 dB
foaming	Please contact your Endress+Hauser sales representative.
Bulk material surface	Attenuation
hard, rough (e.g. rubble)	40 dB
soft (e.g. peat, dust-covered clinker)	40 to 60 dB
Dust	Attenuation
no dust formation	0 dB
little dust formation	5 dB
heavy dust formation	5 to 20 dB
Filling curtain in detection range	Attenuation
none	0 dB
small quantities	5 dB
large quantities	5 to 20 dB
Temperature difference between sensor and product surface	Attenuation
to 20 °C (68 °F)	0 dB
to 40 °C (104 °F)	5 to 10 dB
to 80 °C (176 °F)	10 to 20 dB

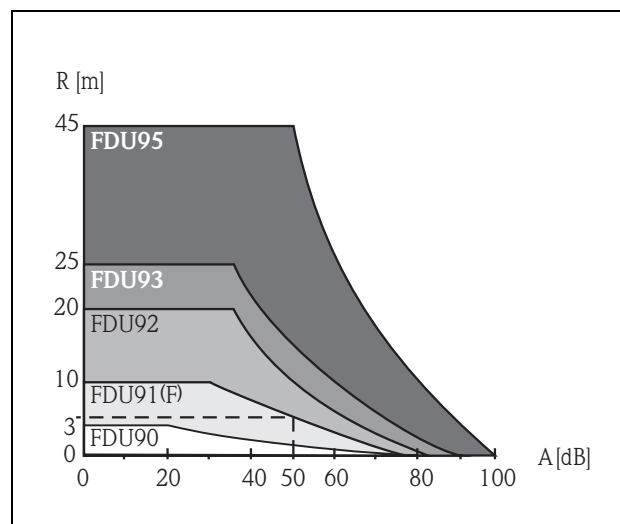

### Example for FDU91(F)

- Silo with rubble: ~ 40 dB
- Small quantities of filling curtain: ~ 5 dB
- Little dust: ~ 5 dB

Attenuation total: ~ 50 dB

⇒ Range approx. 5 m (16 ft)

A: Attenuation (dB)  
R: Range (m)

These measuring conditions have been taken into account during the calculation of the maximum measuring range in solid applications.

**Operating frequency**

Sensor	Operating frequency
FDU90	90 kHz
FDU91	43 kHz
FDU91F	42 kHz
FDU92	30 kHz
FDU93	27 kHz
FDU95 - *1*** (low temperature version)	17 kHz
FDU95 - *2*** (high temperature version)	18 kHz

## Output

**Signal transmission** analogue voltages

## Power supply

**Power supply** supplied by the transmitter FMU90

**Sensor heater (for FDU91)** The FDU90 and FDU91 sensors are optionally available in a version with sensor heater.



The sensor heater needs an external power supply.

The power for the heater can be supplied by the power supply RNB130 from Endress+Hauser (→ 30).

The power supply for the sensor heater is connected to the brown (BN) and blue (BU) strand of the sensor cable.

**Technical data**

- 24 VDC ±10 %; residual ripple < 100 mV
- 250 mA per sensor



- If the sensor heater is applied, the integrated temperature sensor can not be used. Instead, an external temperature sensor (Pt100 or FMT131 from Endress+Hauser) must be used.
- The transmitter FMU90 is available in a version with an input for the external temperature sensor. For details refer to Technical Information TI00397F.

## Electrical connection

### Connection diagram

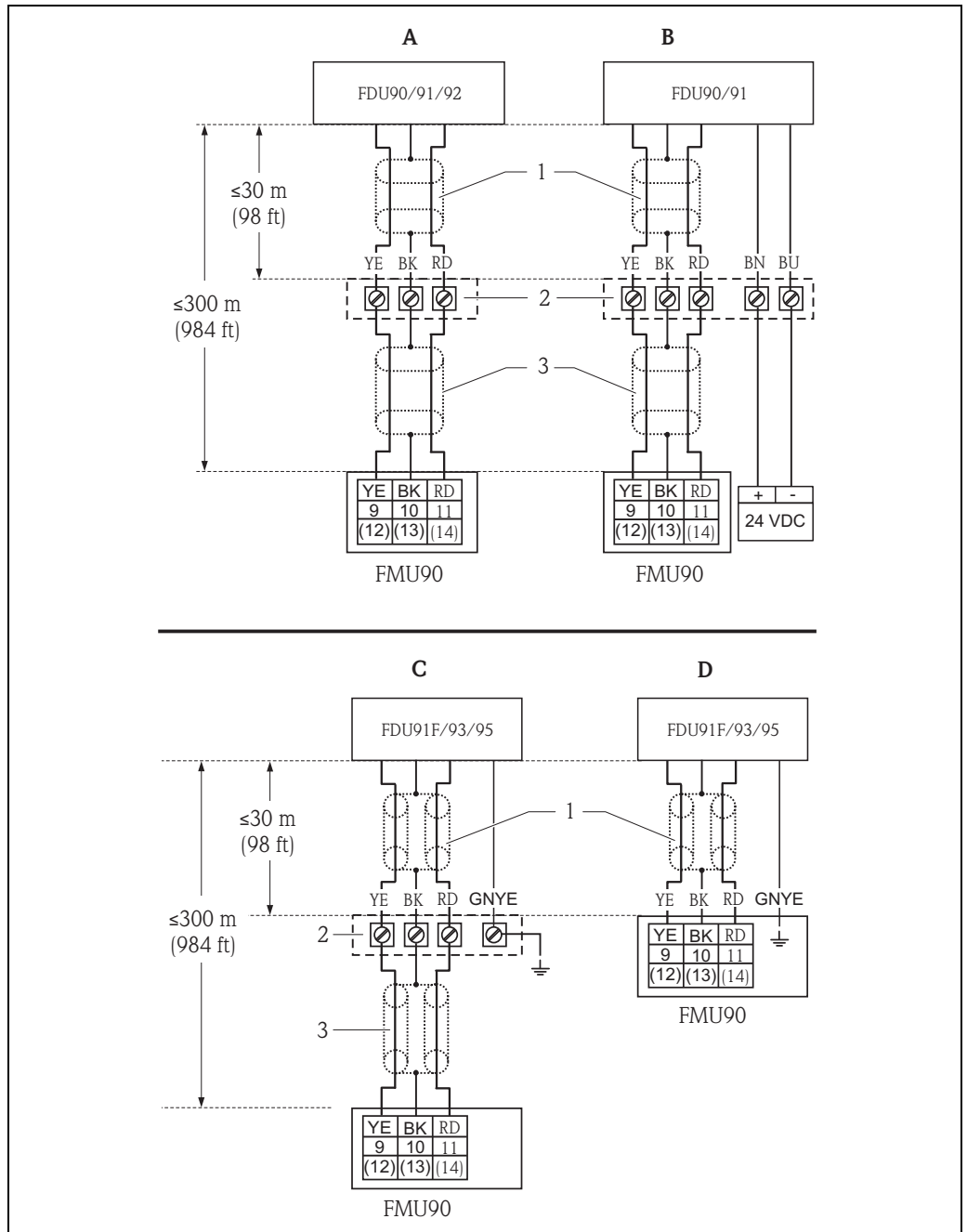

L00-FDU9xxxx-04-00-00-xx-002

- A** Without sensor heater
- B** With sensor heater
- C** Grounding at the terminal box
- D** Grounding at the transmitter FMU90

- 1 Shield of the sensor cable
- 2 Terminal box
- 3 Shield of the extension cable

Colours of the strands: YE = yellow; BK = black; RD = red; BU = blue; BN = brown; GNYE = green-yellow

**Connection hints**

In order to avoid interference, do not route the sensor cables parallel to high-voltage or electric power lines and not close to frequency converters.

**⚠ WARNING****Limitation of electrical safety.**

- ▶ The protective conductor (GNYE) of the sensors FDU91F/93/95 must be connected to the local potential equalization **after a maximum distance of 30 m (98 ft)**.

The protective conductor (GNYE) of the sensors can be connected at this locations:

- Terminal box
- Transmitter FMU90
- Cabinet



The cable shield serves as a return cable and must be connected to the transmitter without any electrical break. With the preassembled cables, the shield ends in a black strand (BK). With the extension cable, the shield must be twisted together and connected to the "BK" terminal. The cable shield must not be connected to the local potential equalization.

For easier mounting it is advisable to use the sensors FDU90/91/92 with a maximum cable length of 30 m (98 ft) as well. For longer distances an extension cable with a terminal box should be used.

**Extension cables for the sensors**

For distances up to 30 m (98 ft) the sensor can be directly connected by the sensor cable. For longer distances, it is recommended to use an extension cable. The extension cable is connected via a terminal box. The total length (sensor cable + extension cable) may be up to 300 m (984 ft).

**⚠ WARNING****Explosion hazard!**

In explosion hazardous areas, sparks can cause explosions. This may lead to serious or fatal injury. Additionally, the device and installation may be seriously damaged.

- ▶ If the terminal box is installed in explosion hazardous areas, all applicable national guidelines must be observed.
- ▶ Pay attention to the measures and notes in Chapter **Certificates and Approvals** → 21.

Suitable extension cables can be obtained from Endress+Hauser (→ 23 "Accessories")  
Alternatively, cables with the following properties can be used:

- Number of cores according to the connection diagram (→ 7 "Connection diagram")
- Braided wire shield for the yellow (YE) and red (RD) core (no foil shield)
- Length: up to 300 m (984 ft), sensor cable + extension cable
- Cross section: 0.75 mm<sup>2</sup> to 2.5 mm<sup>2</sup> (18 to 14 AWG)
- Up to 8 Ω per core
- Max. 60 nF (between core and shield)
- For FDU91F/93/95: The protective conductor (GNYE) must not be within the shield.

**Shortening the sensor cable**

If required, the sensor cable can be shortened. Please note:

- Do not damage the cores when removing the insulation.
- The cable is shielded by a metallic braiding. This shielding serves as a return cable and corresponds to the black (BK) strand of the unshortened cable. After shortening the cable, loosen the metallic braiding, twist it together securely and connect it to the "BK" terminal.

**i** The protective conductor (GNYE), which is present in some of the sensor cables, may **not** be electrically connected to the cable shield.

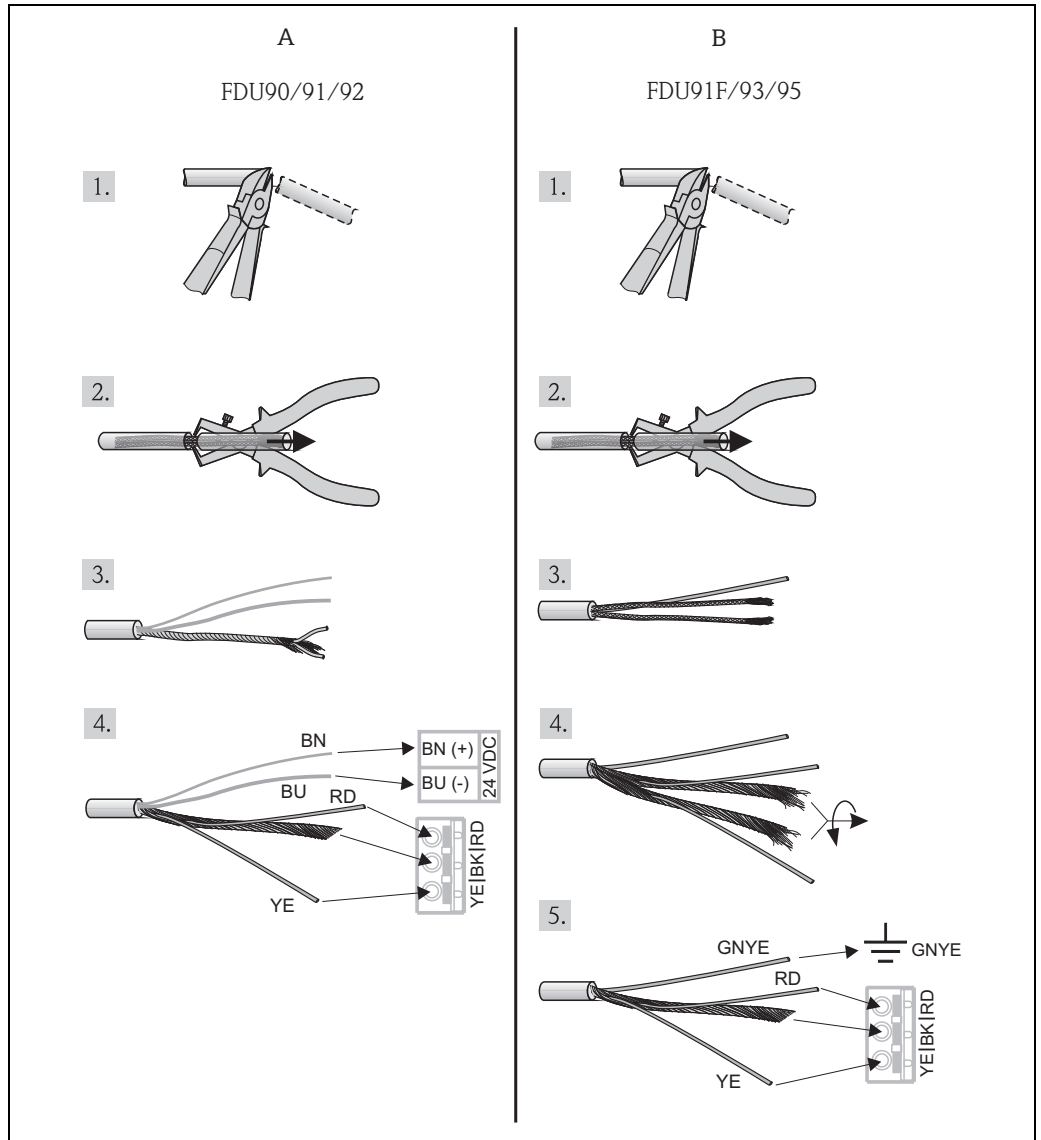

L00-FMU90xxx-04-00-00-xx-015

Colours of the strands: YE = yellow; BK = black; RD = red; BU = blue; BN = brown; GNYE = green-yellow

**i** The blue (BU) and brown (BN) strands is only present for sensors with heater.

## Installation

### **⚠ WARNING**

#### Hazard of accidents!

If sensors are not fastened properly, they can fall down and cause serious injury and property damage.

- ▶ Only install sensors in areas that are stable and sufficiently able to take the load.
- ▶ Fasten sensors only with fastening material that is proper and suited for the environment.

### **NOTICE**

#### Risk of sensor damage.

- ▶ Do not use the sensor cable for suspension.
- ▶ Protect sensor membrane from damage during installation.

### Installation options (Examples)

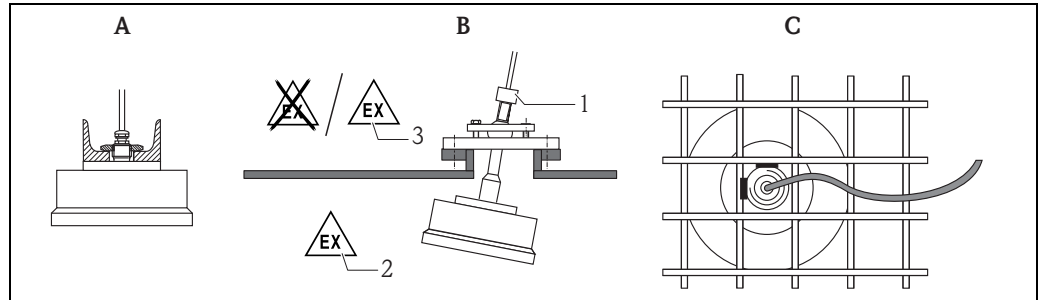

- 1 FAU40  
2 Zone 20  
3 Zone 21

**A:** at girder or angle bracket, **B:** with alignment unit FAU40, in ATEX Zone 20 the alignment unit can be used for zone separation, **C:** with a 1" sleeve welded to a grating

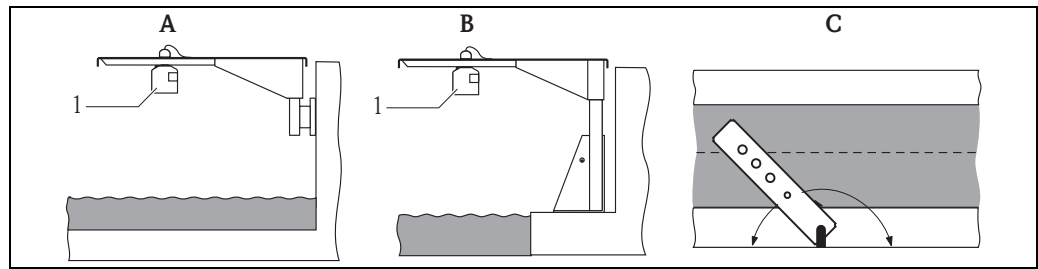

- 1 FDU9x

**A:** Installation with cantilever and wall bracket, **B:** Installation with cantilever and mounting frame, **C:** The cantilever can be turned in order to position the sensor over the centre of the flume.

Cantilever, wall bracket and mounting frame are available as accessories (→ 23).

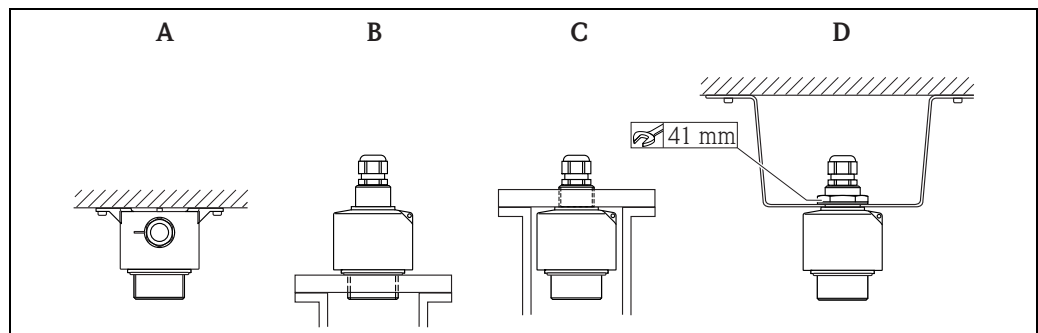

- A:** FDU90: Ceiling mounting  
**B:** FDU90: Mounted at front thread (G 1½" or NPT 1½")  
**C:** FDU9x: Mounted at rear thread (G 1" or NPT 1")  
**D:** FDU90, FDU91, FDU92: Mounting with G 1" counter nut <sup>1)</sup>

1) The counter nut with gasket is supplied for the sensors FDU90, FDU91 and FDU92 with a metric thread G 1" at the process connection.

**Installation conditions for level measurements**

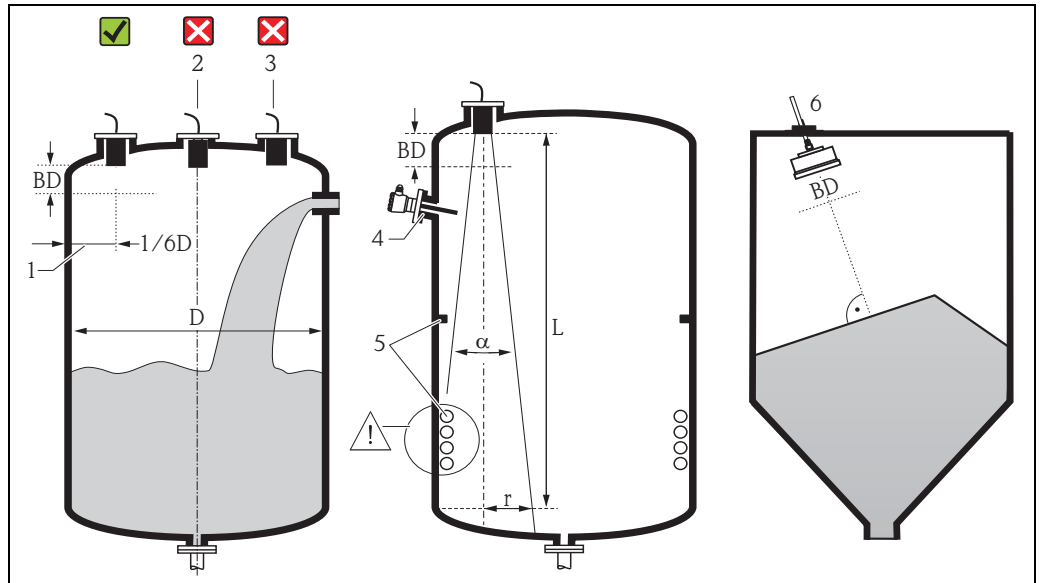

L00-FDU9xxxx-17-00-00-xx-003

- If possible, install the sensor so that its lower edge projects into the vessel.
- Make sure, that the maximum level does not reach into the blocking distance (BD, see table).
- Do not install the sensor in the middle of the tank (2). We recommend leaving a distance (1) between the sensor and the tank wall measuring 1/6 of the tank diameter.
- Avoid measurements through the filling curtain (3).
- Make sure that equipment (4) such as limit switches, temperature sensors, baffles etc. are not located within the emitting angle  $\alpha$ . Emitting angles of the individual sensors are given in the table below. In particular, symmetrical equipment (5) such as heating coils etc. can influence the measurement.
- Align the sensor vertically to the product surface (6). An alignment unit (FAU40) is available as an accessory (→ 23).
- If the two-channel version of the transmitter FMU90 or the multi-channel version of the transmitter FMU90 is used, both sensors can be mounted in one vessel.
- To estimate the detection range, use the 3 dB emitting angle  $\alpha$ :

Sensor	$\alpha$ (typically)	L (max)	r (max)
FDU90	12°	3 (9.8)	0.31 (1.0)
FDU91	9°	10 (33)	0.79 (2.6)
FDU91F	12°	10 (33)	1.05 (3.4)
FDU92	11°	20 (66)	1.92 (6.3)
FDU93	4°	25 (82)	0.87 (2.9)
FDU95	5°	45 (148)	1.96 (6.4)

m (ft)

**▲ WARNING**

**Explosion hazard!**

In explosion hazardous areas, sparks can cause explosions. This may lead to serious or fatal injury. Additionally, the device and installation may be seriously damaged.

- ▶ Pay attention to the measures and notes in Chapter **Certificates and Approvals** (see → 21).

### Installation conditions for flow measurements

- Install the sensor at the inflow side (B), above the maximum water level  $H_{\max}$  (=F) plus the blocking distance BD.
- Position the sensor in the middle of the channel or weir.
- Align the sensor vertically to the water surface.
- Comply to the installation distance of the channel or weir.<sup>2)</sup>
- Use a protective cover, in order to protect the sensor from direct sun or rain. A protective cover is available for the sensors FDU90 and FDU91 (→ 23).

#### Example: Khafagi-Venturi flume

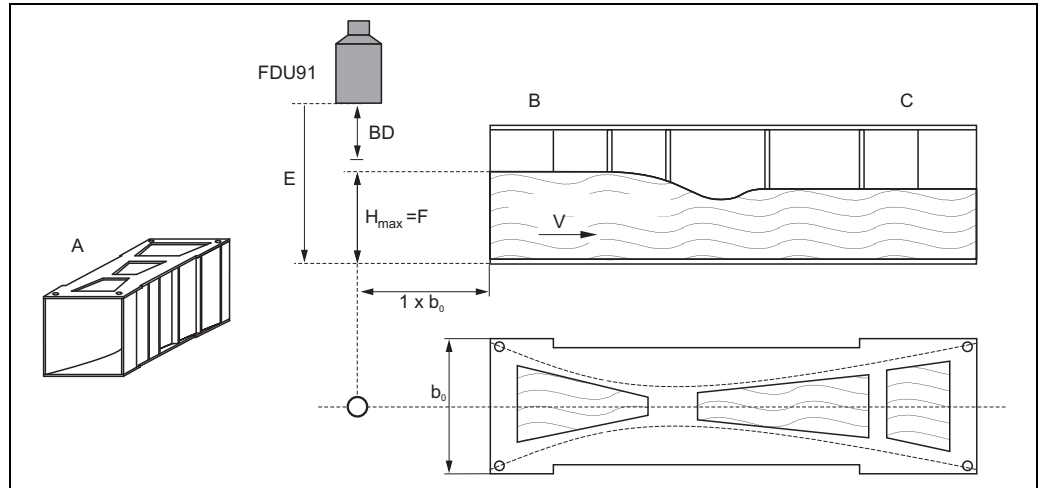

A: Khafagi-Venturi flume, B: inflow, C: outflow, BD: blocking distance, E: empty calibration, F: full calibration, V: direction of flow

#### Example: V-notch weir

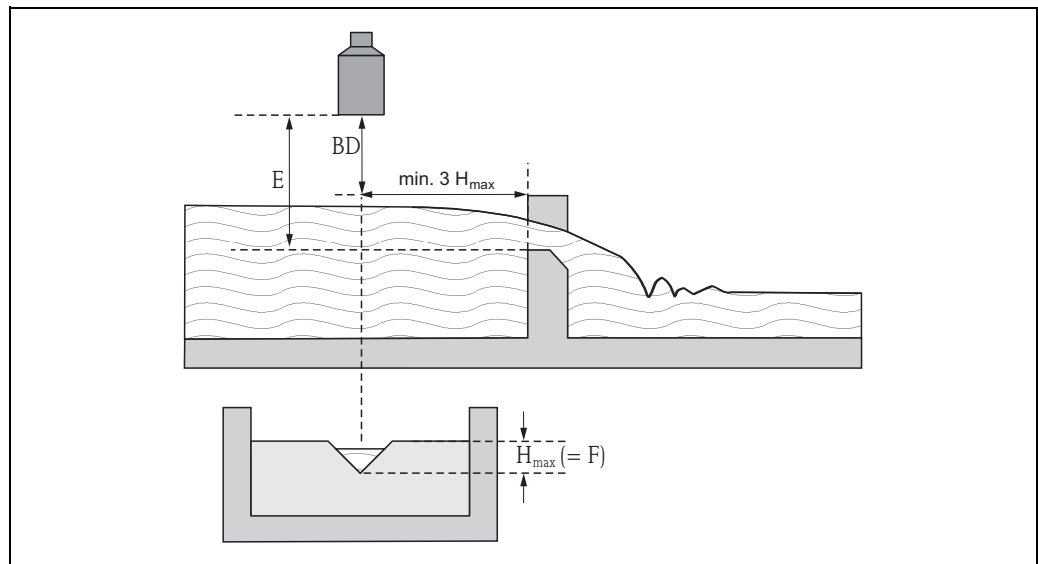

BD: blocking distance, E: empty calibration, F: full calibration

2) The installation distances of important flumes and weirs are specified in the Operating Instructions BA00289F (FMU90 with HART) and BA00293F (FMU90 with PROFIBUS).

**Flush mounting with slip-on flange FAU80**

The FDU91F sensor can be flush mounted using a FAU80 slip-on flange. Flanges in polypropylene (PP-FR) should only be used with pressures up to 1.5 bar<sub>abs</sub> (22 psi abs), flanges in 316L also above.

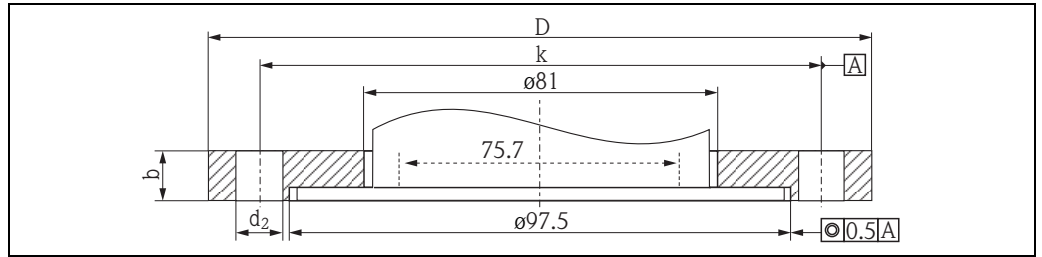

L00-FDU9xxxx-17-00-00-xx-009

Order code	Material	b [mm (in)]	øD [mm (in)]	ød2 [mm (in)]	k [mm (in)]	No. d2	Standard
FAU80 - CAP	PP-FR	20 (0.79)	200 (7.87)	18 (0.71)	160 (6.3)	8	DN80 PN16 A (DIN EN 1092-1 (DIN2527 B))
FAU80 - CAJ	316L (1.4435)						
FAU80 - AAP	PP-FR	23.9 (0.94)	190.5 (7.5)	19.1 (0.75)	152.4 (6.0)	4	ANSI 3" 150 lbs FF (ANSI B 16.5)
FAU80 - AAJ	316L (1.4435)						
FAU80 - KAP	PP-FR	18 (0.71)	185 (7.28)	19 (0.75)	150 (5.9)	8	JIS 10K 80A FF (JIS B 2220)
FAU80 - KAJ	316L (1.4435)						

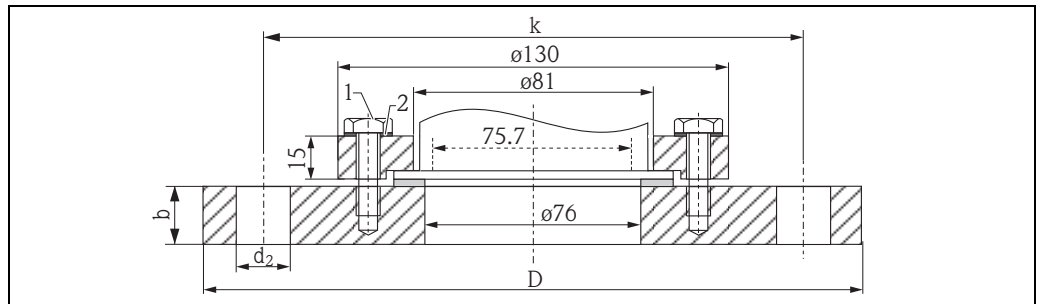

L00-FDU9xxxx-17-00-00-xx-010

The adapter flange and the screws are included in the delivery.

Position	Part	Material
1	Screws	V2A
2	Washer	PP-FR or 316/316L (1.4435)

Order code	Material	b [mm]	øD [mm]	ød2 [mm]	k [mm]	No. d2	Standard
FAU80 - CHP	PP-FR	20 (0.79)	220 (8.66)	18 (0.71)	180 (7.09)	8	DN100 PN16 A (DIN EN 1092-1 (DIN2527 B))
FAU80 - CHJ	316L (1.4435)						
FAU80 - AHP	PP-FR	23.9 (0.94)	228.6 (9.0)	19.1 (0.75)	190.5 (7.5)	4	ANSI 4" 150 lbs FF (ANSI B 16.5)
FAU80 - AHJ	316L (1.4435)						
FAU80 - KHP	PP-FR	18 (0.71)	210 (8.27)	19 (0.75)	175 (6.89)	8	JIS 10K 100A FF (JIS B 2220)
FAU80 - KHJ	316L (1.4435)						

-  The **process seal** is not included in the delivery.
- Endress+Hauser supplies **DIN/EN flanges made of stainless steel** AISI 316L with the material number 1.4404 or 1.4435. With regard to their temperature stability properties, the materials 1.4404 and 1.4435 are grouped under 13EO in EN 1092-1 Tab. 18. The chemical composition of the two materials can be identical.
- For **3A-applications**: The internal diameter of the nozzle should be selected according to the valid allowable limits for 3A applications. Usually, the internal diameter of the nozzle should be larger than or equal to the internal diameter of the sensor.

## Nozzle installation

Install the sensor at a height so that the blocking distance BD is not undershot, even at maximum fill level. Use a pipe nozzle if you cannot maintain the blocking distance in any other way. The interior of the nozzle must be smooth and may not contain any edges or welded joints. In particular, there should be no burr on the inside of the tank side nozzle end. Note the specified limits for nozzle diameter and length. To minimise disturbing factors, we recommend an angled socket edge (ideally 45°).

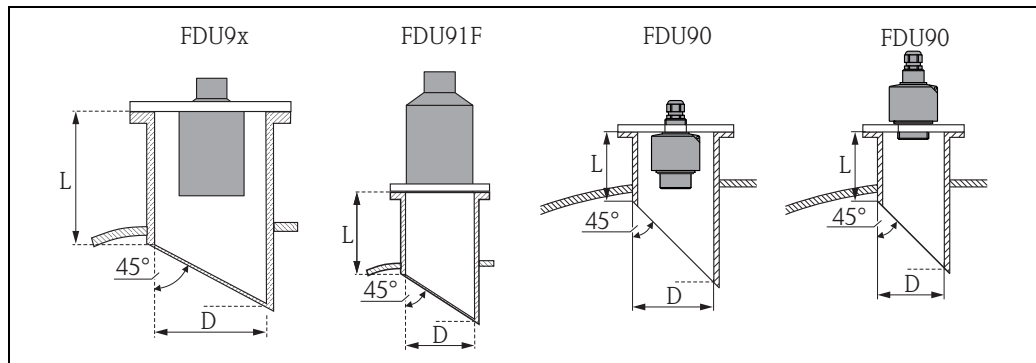

L00-FDU9xxxx-17-00-00-xx-006

Nozzle diameter	Maximum nozzle length [mm (in)]						
	FDU90 <sup>1)</sup>	FDU90 <sup>2)</sup>	FDU91	FDU91F	FDU92	FDU93	FDU95
DN50/2"	–	50 (1.97)	–	–	–	–	–
DN80/3"	340 (13.4)	250 (9.84)	340 (13.4)	250 (9.84) <sup>3)</sup>	–	–	–
DN100/4"	390 (15.4)	300 (11.8)	390 (15.4)	300 (11.8) <sup>3)</sup>	–	–	–
DN150/6"	400 (15.7)	300 (11.8)	400 (15.7)	300(11.8) <sup>3)</sup>	400 (15.7)	–	–
DN200/8"	400 (15.7)	300 (11.8)	400 (15.7)	300(11.8) <sup>3)</sup>	400 (15.7)	520 (20.5)	–
DN250/10"	400 (15.7)	300 (11.8)	400 (15.7)	300(11.8) <sup>3)</sup>	400 (15.7)	520 (20.5)	630 (24.8)
DN300/12"	400 (15.7)	300 (11.8)	400 (15.7)	300(11.8) <sup>3)</sup>	400 (15.7)	520 (20.5)	630 (24.8)
<b>Sensor characteristics</b>							
Emission angle $\alpha$	12°	12°	9°	12°	11°	4°	5°
Blocking distance [m (ft)]	0.07 (0.2)	0.07 (0.2)	0.3 (1)	0.3 (1)	0.4 (1.3)	0.6 (2)	0.7 (2.3)
Max. measuring range [m (ft)] in liquids	3 (9.8)	3 (9.8)	10 (33)	10 (33)	20 (66)	25 (82)	–
Max. measuring range [m] in solids	1.2 (3.9)	1.2 (3.9)	5 (16)	5 (16)	10 (33)	15 (49)	45 (148)

- 1) mounted at the rear side thread
- 2) mounted at the front side thread (flush mounting)
- 3) Valid for flush mounting; for mounting with G/NPT 1" and DN100 or higher see FDU91.

### Ultrasound guide pipe

In narrow shafts with strong interference echoes, we recommend using an ultrasound guide pipe (e.g. PE or PVC wastewater pipe) with a minimum diameter of DN80 for FDU90, DN100 for FDU91, DN200 for FDU92.

Make sure that the pipe is not soiled by accumulated dirt. If necessary, clean the pipe at regular intervals

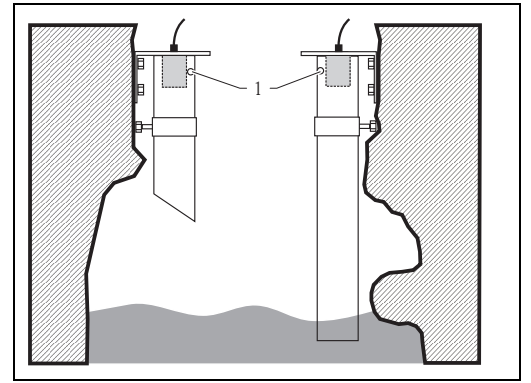

L00-FDU9xxxx-17-00-00-xx-008

1 Venting hole

## Environment

<b>Ingress protection</b>	Tested according to IP68/NEMA6P (24 h at 6 ft under water surface)
<b>Vibration resistance</b>	DIN EN 600068-2-64; 20 to 2000 Hz; 1 (m/s <sup>2</sup> ) <sup>2</sup> /Hz; 3x100 min.
<b>Storage temperature</b>	Identical to process temperature, see below
<b>Thermal shock resistance</b>	According to DIN EN 60068-2-14; examination to min/max process temperature; 0.5 K/min; 1000 h
<b>Electromagnetic compatibility</b>	Electromagnetic compatibility according to all relevant requirements of the EN 61326- series and NAMUR recommendation EMC (NE21). For details see declaration of conformity. With respect to interference emission the devices meet the requirements of class A and are only provided for use in an "industrial environment"!
<b>Explosion hazardous area</b>	Pay attention to the measures and notes in Chapter Certificates and Approvals → 21.

## Process

Process temperature,  
Process pressure

Sensor	Process temperature	Process pressure (abs.)
FDU90	-40 to +80 °C (-40 to +176 °F) <sup>1</sup>	0.7 to 4 bar (10.15 to 58 psi)
FDU91	-40 to +80 °C (-40 to +176 °F) <sup>1</sup>	0.7 to 4 bar (10.15 to 58 psi)
FDU91F	-40 to +105 °C (-40 to +221 °F) (30 min/135 °C (275 °F)) <sup>2</sup> for Ex instruments: -40 to +80 °C (-40 to +176 °F)	0.7 to 4 bar (10.15 to 58 psi)
FDU92	-40 to +95 °C (-40 to +203 °F) for Ex instruments: -40 to +80 °C (-40 to +176 °F)	0.7 to 4 bar (10.15 to 58 psi)
FDU93	-40 to +95 °C (-40 to +203 °F) for Ex instruments: -40 to +80 °C (-40 to +176 °F)	0.7 to 3 bar (10.15 to 43.5 psi)
FDU95 - *1*** (low temperature version)	-40 to +80 °C (-40 to +176 °F)	0.7 to 1.5 bar (10.15 to 22 psi)
FDU95 - *2*** (high temperature version)	-40 to +150 °C (-40 to +302 °F) for Dust-Ex versions: -40 to +130 °C	0.7 to 1.5 bar (10.15 to 22 psi)

- 1) In order to avoid ice build-up, the sensors FDU90 and FDU91 are available in a version with integrated sensor heater (→ 6). If this heater is used, an external temperature sensor has to be applied for time-of-flight correction. The transmitter FMU90 is available in a version with an input for the external temperature sensor. For details refer to Technical Information TI00397F.
- 2) Only valid for Tri-clamp and flush mounting

## Mechanical construction

### Counter nut G 1"

- Is supplied for the sensor FDU90, FDU91 and FDU92 with a metric G 1" thread.
- Material: PA6.6
- Gasket (EPDM) is supplied

Note!

The counter nut is not for NPT thread.

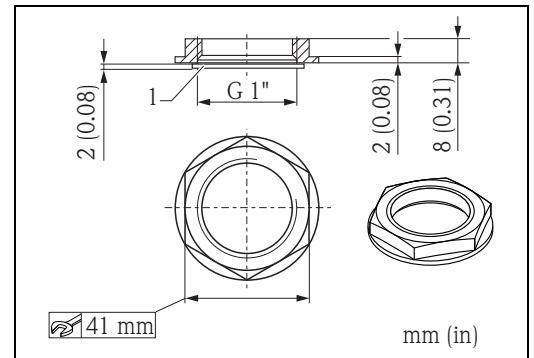

1 Gasket

### Dimensions FDU90

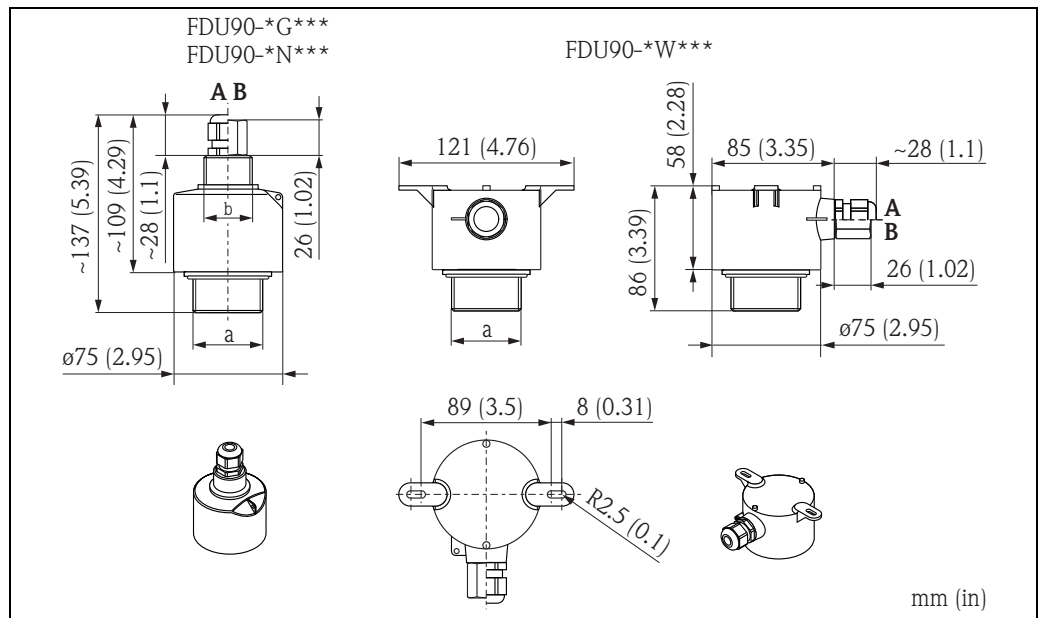

A: Cable gland for approval versions FDU90-C/D/E/G/H/J/R/U/V/1

B: Conduit connection NPT 1/2" for approval versions FDU90-Q/S

The conduit connection is partly potted (half-filled)

a: G 1-1/2" or NPT 1-1/2" (see product structure: 020 "Process connection" → §21)

b: G 1" or NPT 1" (see product structure: 020 "Process connection" → §21)

### Dimensions FDU91

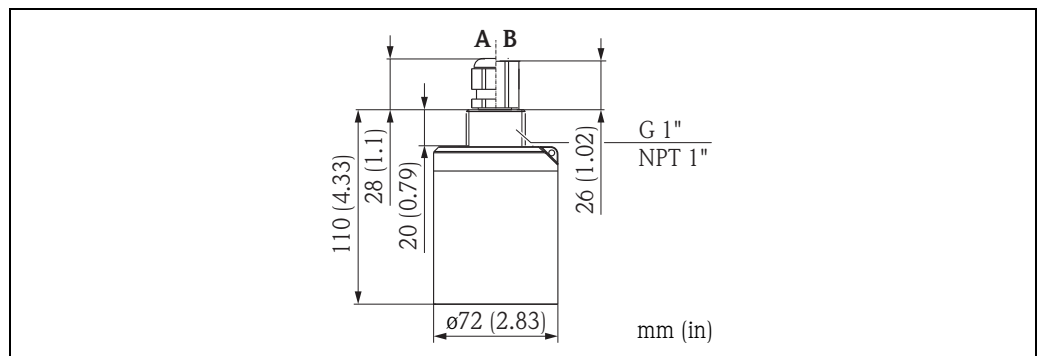

A: Cable gland for approval versions FDU91-C/D/E/G/H/J/R/U/V/1

B: Conduit connection NPT 1/2" for approval versions FDU91-Q/S

The conduit connection is partly potted (half-filled).

**Dimensions FDU91F**

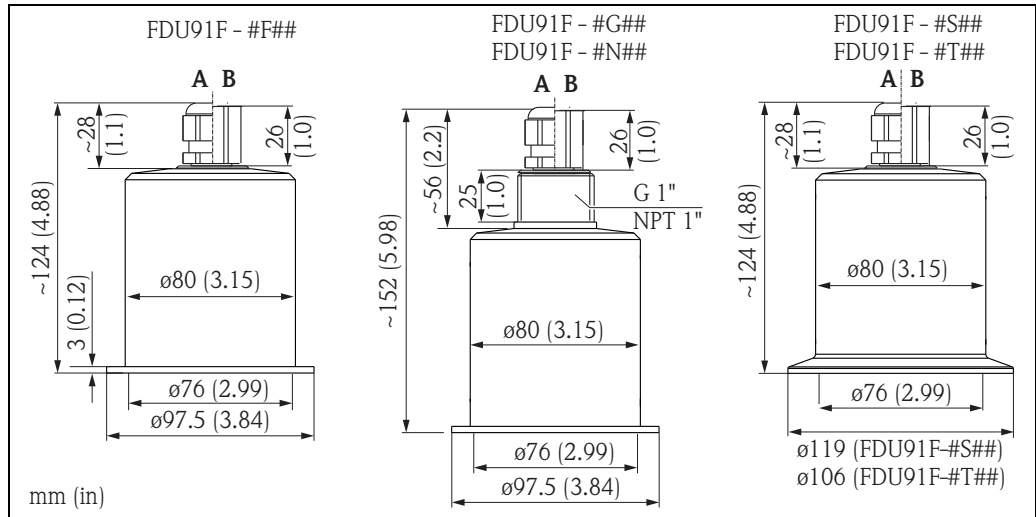

L00-FDU91Fxxx-06-00-00-xx-001

A: Cable gland for approval versions FDU91F-C/D/E/G/H/J/R/U/V  
 B: Conduit connection NPT 1/2" for approval versions FDU91F-Q/S  
 The conduit connection is partly potted (half-filled).

**Dimensions FDU92**

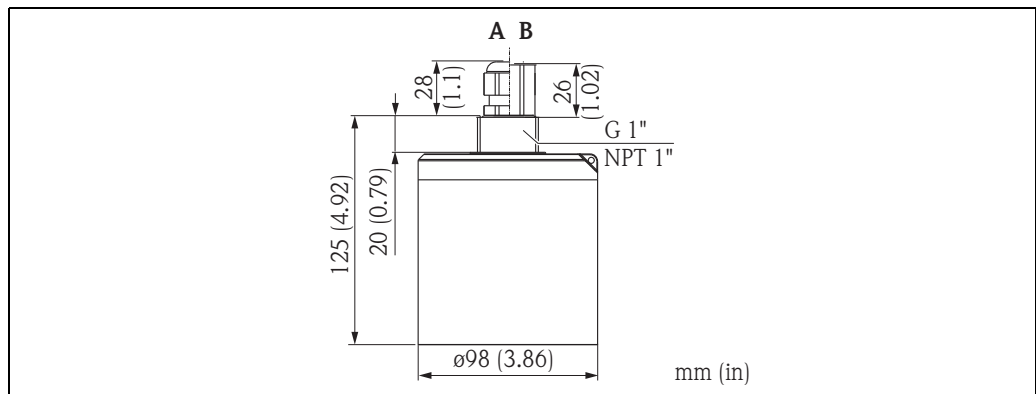

L00-FDU92xxx-06-00-00-xx-001

A: Cable gland for approval versions FDU92-C/D/E/G/H/J/R/U/V/1  
 B: Conduit connection NPT 1/2" for approval versions FDU92-Q/S  
 The conduit connection is partly potted (half-filled).

**Dimensions FDU93**

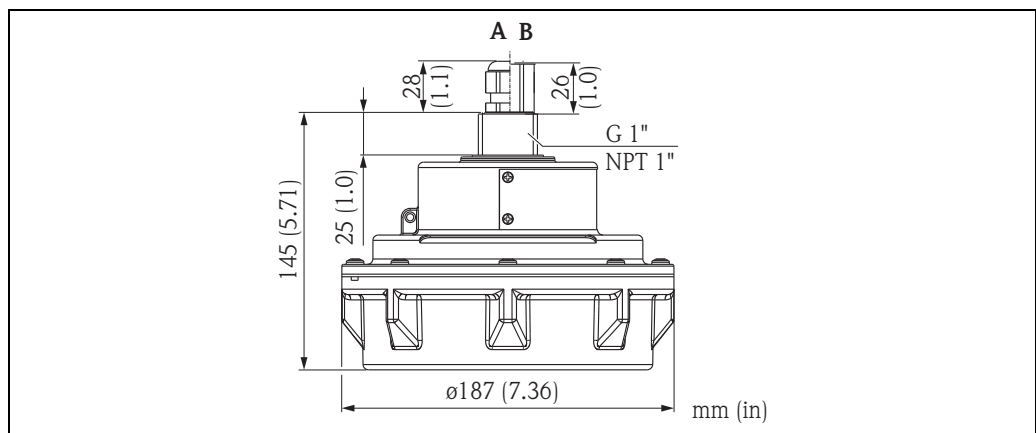

L00-FDU93xxx-06-00-00-xx-001

A: Cable gland for approval version FDU93-C/D/E/G/H/J/R/U/W/1  
 B: Conduit connection NPT 1/2" for approval versions FDU93-P/T  
 The conduit connection is partly potted (half-filled).

**Dimensions FDU95**

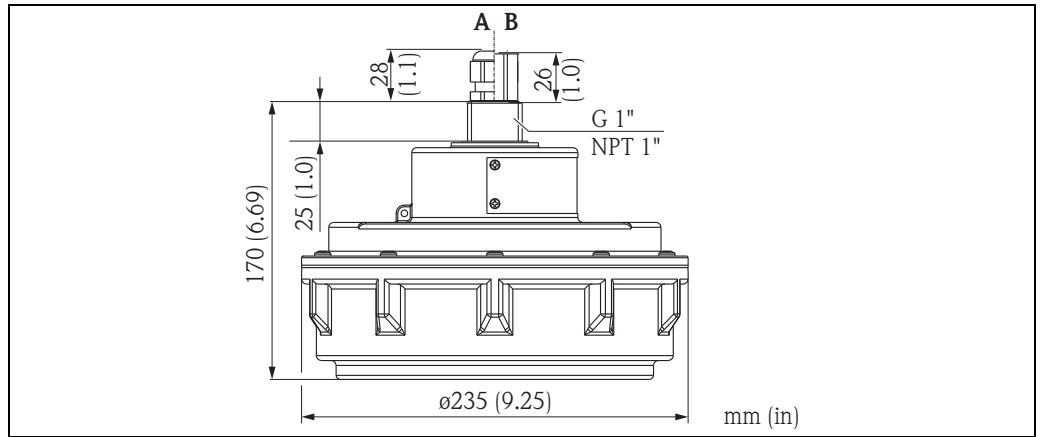

A: Cable gland for approval versions FDU95-C/D/E/H/J/R/U/W/1  
 B: Conduit connection NPT 1/2" for approval versions FDU95-P/T  
 The conduit connection is partly potted (half-filled).

L00-FDU95xxx-06-00-00-xx-001

**Weight**

Sensor	Weight (including 5 m (16 ft) cable)
FDU90	<ul style="list-style-type: none"> <li>■ approx. 0.9 kg (1.98 lbs) without flooding protection tube</li> <li>■ approx. 1.0 kg (2.21 lbs) with flooding protection tube</li> </ul>
FDU91	approx. 1.1 kg (2.43 lbs)
FDU91F	approx. 1.6 kg (3.53 lbs)
FDU92	approx. 2 kg (4.41 lbs)
FDU93	approx. 2.9 kg (6.39 lbs)
FDU95	approx. 4.5 kg (9.92 lbs)

**Materials**

**NOTICE**

**Risk of sensor damage caused by chemical substances.**

- ▶ Prior to application, check the chemical compatibility of the sensors with compatibility charts.

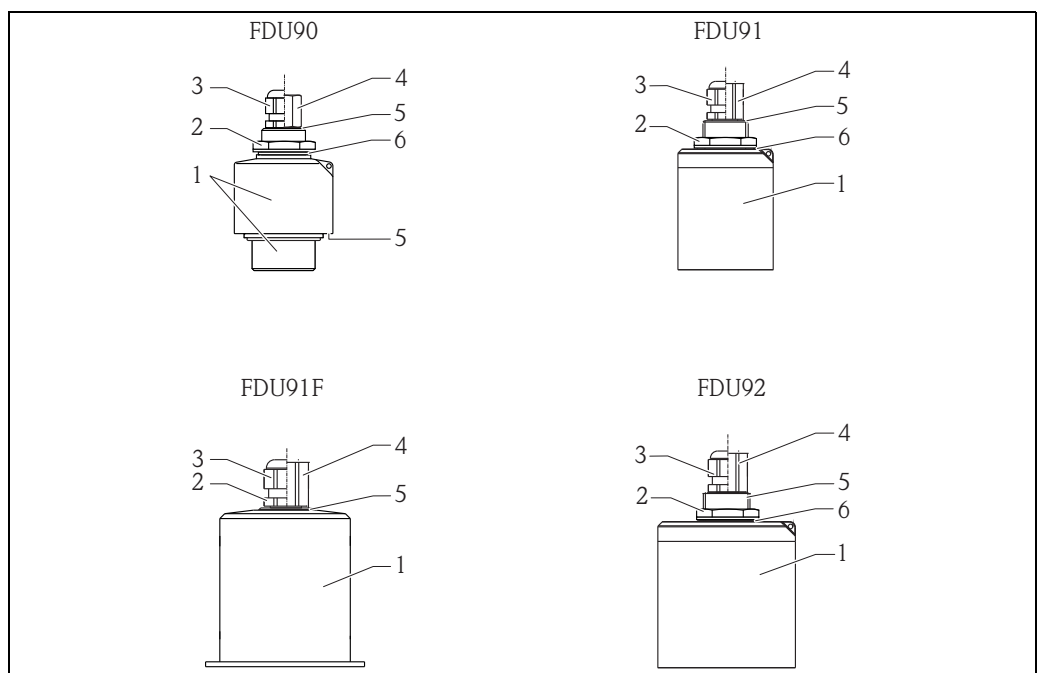

L00-FDU9xxx-16-00-00-xx-001

Pos.	Part	FDU90	FDU91	FDU91F	FDU92
1	Sensor housing	PVDF		316L (1.4404/1.4435)	PVDF
2	Counter nut	PA6.6		–	PA6.6
3	Cable gland	PA			
4	Adpater	CuZn nickel-plated			
5	O-ring	EPDM			
6	Sealing				

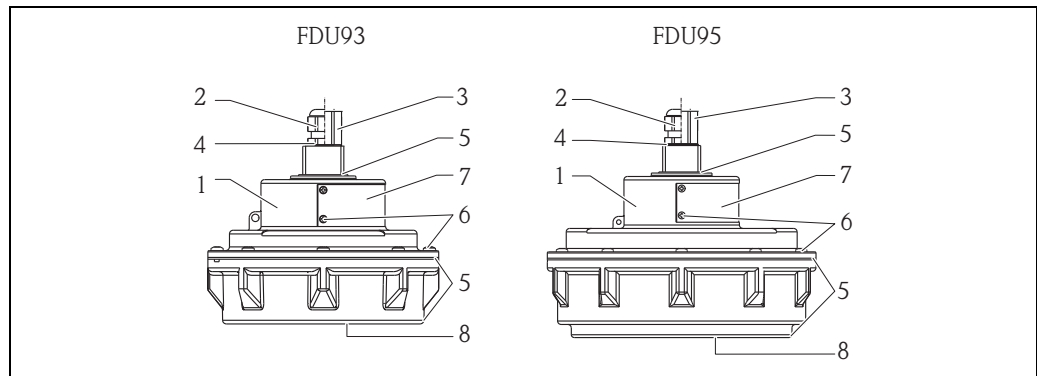

L00-FDU9xxxx-16-00-00-xx-002

Pos.	Part	FDU93	FDU95
1	Sensor	UP (Unsaturated polyester resin)	
2	Cable gland	CuZn nickel-plated	
3	Adpater	CuZn nickel-plated	
4	O-ring	VMQ	
5	Sealing	VMQ	
6	Screws	V2A	
7	Nameplate	304 (1.4301)	
8	Membrane	ALU with PFA coated	FDU95 - *1*** (low temperature version): 316L (1.4404) and PE coated  FDU95 - *2*** (high temperature version): 316L (1.4404)

**Connecting cable**

5 to 300 m (16 to 984 ft)

For cable length > 30 m (> 98 ft), an extension cable is recommended.

In this case, the total length (sensor cable + extension cable) must not exceed 300 m (984 ft).

Cable	Material
for FDU90/91/91F/92/93	PVC
for FDU95	VMQ

## Certificates and Approvals

<b>CE mark</b>	The measuring system meets the legal requirements of the EC-guidelines. Endress+Hauser confirms the instrument passing the required tests by attaching the CE-mark.
<b>Ex approval</b>	<p>The available certificates are listed in the ordering information. Note the associated safety instructions (XA) and control or installation drawings (ZD).</p> <p>Warning!</p> <ul style="list-style-type: none"> <li>■ Measuring systems for use in hazardous environments are accompanied by separate "Ex documentation", which is an integral part of this Operating Manual. Strict compliance with the installation instructions and ratings as stated in this supplementary documentation is mandatory. <ul style="list-style-type: none"> <li>– Ensure that all personnel are suitably qualified.</li> <li>– Observe the specifications in the certificate as well as national and local standards and regulations.</li> </ul> </li> <li>■ The transmitter may only be installed in suitable areas.</li> <li>■ Sensors with a certificate for hazardous areas may be connected to a transmitter without a certificate.</li> <li>■ For FM approvals: Unauthorized substitution of components may impair the suitability for Division 1 or Division 2.</li> <li>■ Do not disconnect equipment unless the area is known to be non-hazardous.</li> </ul> <p>Note!</p> <p>The sensor must be installed and used in a way that eliminates any danger. Possible installation positions: in tanks, vessels, silos, over stockpiles, open channels, weirs or other bins.</p>
<b>External standards and directives</b>	<p><b>EN 60529</b> Protection class of housing (IP code)</p> <p><b>EN 61326 series</b> EMC product family standard for electrical equipment for measurement, control and laboratory use</p> <p><b>NAMUR</b> User association for automation technology in process industries</p>

## Ordering information

<b>Ordering information</b>	<p>Detailed ordering information is available from the following sources:</p> <ul style="list-style-type: none"> <li>■ In the Product Configurator on the Endress+Hauser web site: <a href="http://www.endress.com">www.endress.com</a> → Choose your country → Products → Select measuring technology, software or components → Select product (picklists: measurement method, product family etc.) → Device support (right-hand column): Configure the selected product → The Product Configurator for the selected product is opened.</li> <li>■ From your Endress+Hauser Sales Center: <a href="http://www.addresses.endress.com">www.addresses.endress.com</a></li> </ul> <p> <b>Product Configurator - the tool for individual product configuration</b></p> <ul style="list-style-type: none"> <li>■ Up-to-the-minute configuration data</li> <li>■ Depending on the device: Direct input of measuring point-specific information such as measuring range or operating language</li> <li>■ Automatic verification of exclusion criteria</li> <li>■ Automatic creation of the order code and its breakdown in PDF or Excel output format</li> <li>■ Ability to order directly in the Endress+Hauser Online Shop</li> </ul>
-----------------------------	---

**5-point linearity protocol**

The following must be taken into account if option "5 point linearity protocol" has been selected:

- The five points of the linearity protocol are evenly distributed across the measuring range (0% to 100%). In order to define the measuring range, Empty calibration (E) and Full calibration (F) have to be specified.<sup>3)</sup>
- The following restrictions have to be taken into account when defining E and F:

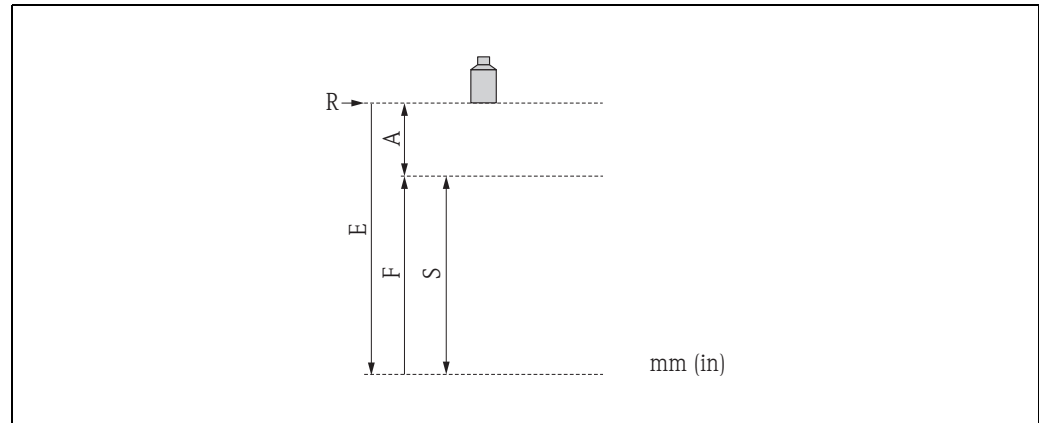

A0019526

Pos.	Measuring range	FDU90	FDU91/ FDU91F	FDU92	FDU93	FDU95
E	Maximum value for the empty calibration	3000 (118)	10000 (394)	20000 (787)	20000 (787)	20000 (787)
F	Maximum value for the full calibration	2900 (114)	9700 (382)	19600 (772)	19400 (764)	18000 (709)
S	Minimum span (E-F)	100 (3.94)	100 (3.94)	200 (7.87)	250 (9.84)	450 (17.7)
A	Minimum distance between reference point R from sensor and 100 % level	160 (6.30)	300 (11.8)	400 (15.7)	600 (23.6)	2000 (78.7)

mm (in)



- The linearity is checked under reference conditions.
- The 5-point linearity protocol is always carried out for the complete measuring system (consisting of the sensor FDU9x and transmitter FMU9x) and it is valid for this combination. It must be defined, at which sensor channel the sensor is to be tested. There are up to 2 channels for FMU90 and up to 5 or 10 channels for FMU95.
- The selected values of **Empty calibration** and **Full calibration** are only used to record the linearity protocol and are reset to default values thereafter.

For details see the Technical Information TI00397F or TI00398F.

**Scope of delivery**

- Instrument according to the version ordered
- This Technical Information (TI00396F/00/EN, serves as installation and operating instruction)
- For certified instrument versions: Safety Instructions (XA) and/or Control Drawings (ZD)
- For FDU90/91 with sensor heater: terminal module, to be mounted in the field housing of the transmitter FMU90
- For FDU90/91/92 with G 1" process connection: counter nut (PA6.6) + seal (EPDM)
- For FDU93/95 with Ex-certificate: process seal (VMQ)

3) If the values for the full calibration and empty calibration are missing or outside the specified area, the devices are tested with the maximum value according to the table.

## Accessories

### Extension cable for sensors

for Sensor	Material	Cable type	Order code
<ul style="list-style-type: none"> <li>▪ FDU90</li> <li>▪ FDU91</li> <li>▪ FDU92</li> </ul>	PVC	LiYCY 2x(0.75)	71027742
<ul style="list-style-type: none"> <li>▪ FDU91F</li> <li>▪ FDU93</li> <li>▪ FDU95</li> </ul>	PVC (-40 to +105 °C) (-40 to +221 °F)	LiYY 2x(0.75)D+1x0.75	71027743
<ul style="list-style-type: none"> <li>▪ FDU95</li> </ul>	Silicone (-40 to +150 °C) (-40 to +302 °F)	Li2G2G 2x(0.75)D+1x0.75	71027745
<ul style="list-style-type: none"> <li>▪ FDU90/FDU91 with heater</li> </ul>	PVC	LiYY 2x(0.75)D+2x0.75	71027746

Total length (sensor cable + extension cable)\*: up to 300 m (984 ft)

\* The sensor cable and the extension cable are of the same type.

### Protective cover for FDU90 and FDU91

- Material: PVDF
- Order code: 52025686

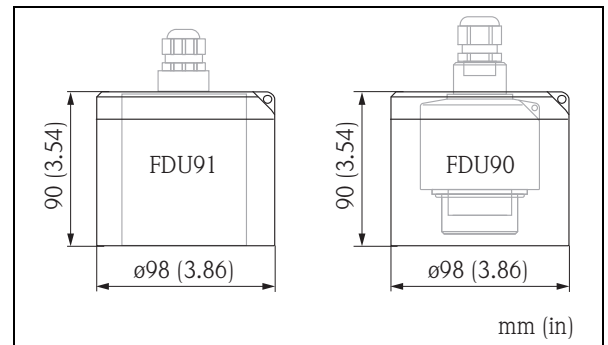

L00-FDU9:xxx-06-00-00-xx-003

Screw in flange FAX50

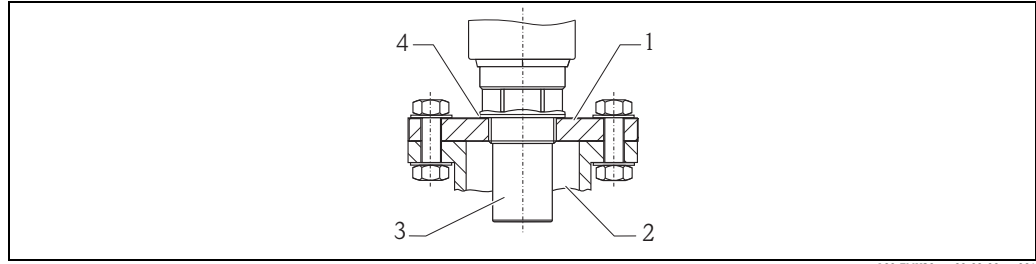

L00-FMU30xxx-00-00-00-xx-001

- 1 Screw in flange
- 2 Nozzle
- 3 Sensor
- 4 Sealing ring EPDM (supplied)

Product structure FAX50

01		Material:
5		
	BR1	DN50 PN10/16 A, steel flange EN1092-1
	BS1	DN80 PN10/16 A, steel flange EN1092-1
	BT1	DN100 PN10/16 A, steel flange EN1092-1
	JF1	2" 150lbs FF, steel flange ANSI B16.5
	JG1	3" 150lbs FF, steel flange ANSI B16.5
	JH1	4" 150lbs FF, steel flange ANSI B16.5
	JK2	8" 150lbs FF, PP max 3bar abs/44psia flange ANSI B16.5
	XIF	UNI flange 2"/DN50/50, PVDF max 4bar abs/58psia, suitable for 2" 150lbs/DN50 PN16/10K 50
	XIG	UNI flange 2"/DN50/50, PP max 4bar abs/58psia, suitable for 2" 150lbs/DN50 PN16/10K 50
	XIJ	UNI flange 2"/DN50/50, 316L max 4bar abs/58psia suitable for 2" 150lbs/DN50 PN16/10K 50
	XJF	UNI flange 3"/DN80/80, max 4bar abs/58psia, suitable for 3" 150lbs/DN80 PN16/10K 80
	XJG	UNI flange 3"/DN80/80, PP max 4bar abs/58psia, suitable for 3" 150lbs/DN80 PN16/10K 80
	XJJ	UNI flange 3"/DN80/80, 316L max 4bar abs/58psia, suitable for 3" 150lbs/DN80 PN16/10K 80
	XKF	UNI flange 4"/DN100/100, PVDF max 4bar abs/58psia, suitable for 4" 150lbs/DN100 PN16/10K 100
	XKG	UNI flange 4"/DN100/100, PP max 4bar abs/58psia, suitable for 4" 150lbs/DN100 PN16/10K 100
	XKJ	UNI flange 4"/DN100/100, 316L max 4bar abs/58psia, suitable for 4" 150lbs/DN100 PN16/10K 100
	XLF	UNI flange 6"/DN150/150, PVDF max 4bar abs/58psia, suitable for 6" 150lbs/DN150 PN16/10K 150
	XLG	UNI flange 6"/DN150/150, PP max 4bar abs/58psia, suitable for 6" 150lbs/DN150 PN16/10K 150
	XLJ	UNI flange 6"/DN150/150, 316L max 4bar abs/58psia, suitable for 6" 150lbs/DN150 PN16/10K 150
	XMG	UNI flange DN200/200, PP max 4bar abs/58psia, suitable for DN200 PN16/10K 200
	XNG	UNI flange DN250/250, PP max 4bar abs/58psia, suitable for DN250 PN16/10K 250
	YYY	Special version
020		Sensor Connection:
	A	Thread ISO228 G3/4
	B	Thread ISO228 G1
	C	Thread ISO228 G1-1/2
	D	Thread ISO228 G2
	E	Thread ANSI NPT3/4
	F	Thread ANSI NPT1
	G	Thread ANSI NPT1-1/2
	H	Thread ANSI NPT2
	Y	Special version

	015	020
FAX50 -		

**Flooding protection tube for FDU90**

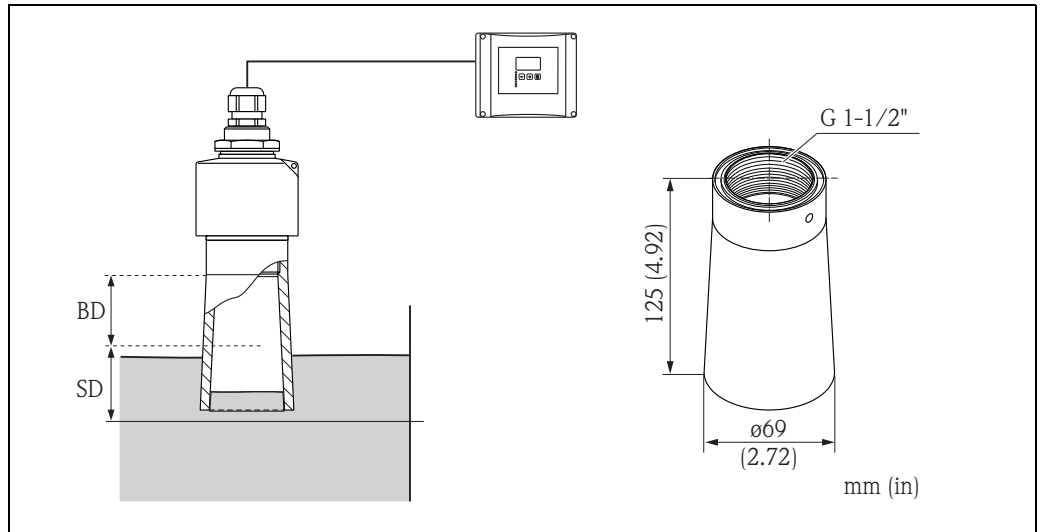

**BD:** Blocking distance, **SD:** Safety distance

**Usage**

The flooding protection tube prevents the level to rise into the blocking distance of the FDU90 sensor even if the sensor is flooded.

The user can set a safety distance SD in the transmitter FMU90/FMU95 and define that a warning signal is generated as soon as the level rises into the safety distance.

**Mounting hints**

In order to ensure tightness, the supplied gasket has to be applied and the flooding protection tube must be screwed hand tight up to limit stop. When re-equipping the flooding protection tube, repeat the basic setup including the mapping

Note!

- The flooding protection tube has a G 1-1/2" thread.
- If it is ordered together with the FDU90 sensor in the product structure, the sensor always has a G 1-1/2" thread at its front side, irrespective of the selection in feature 020, "Process connection".
- If the flooding protection tube is ordered as an accessory, it can only be used for sensors with a G 1-1/2" thread at the front side.

Material	Weight	Order code
PP	0.12 kg (0.26 lbs)	71091216
Gasket EPDM		

**Cantilever with mounting frame or wall bracket**

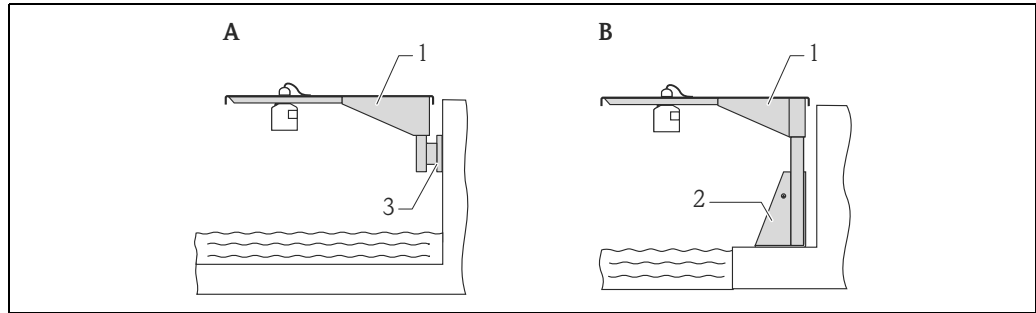

A0019589

- A** Installation with cantilever and wall bracket
- B** Installation with cantilever and mounting frame
- 1** Cantilever
- 2** Mounting frame
- 3** Wall bracket

**Cantilever**

The cantilever is used to mount the sensors FDU90, FDU91 and FDU92 above open channels for example.

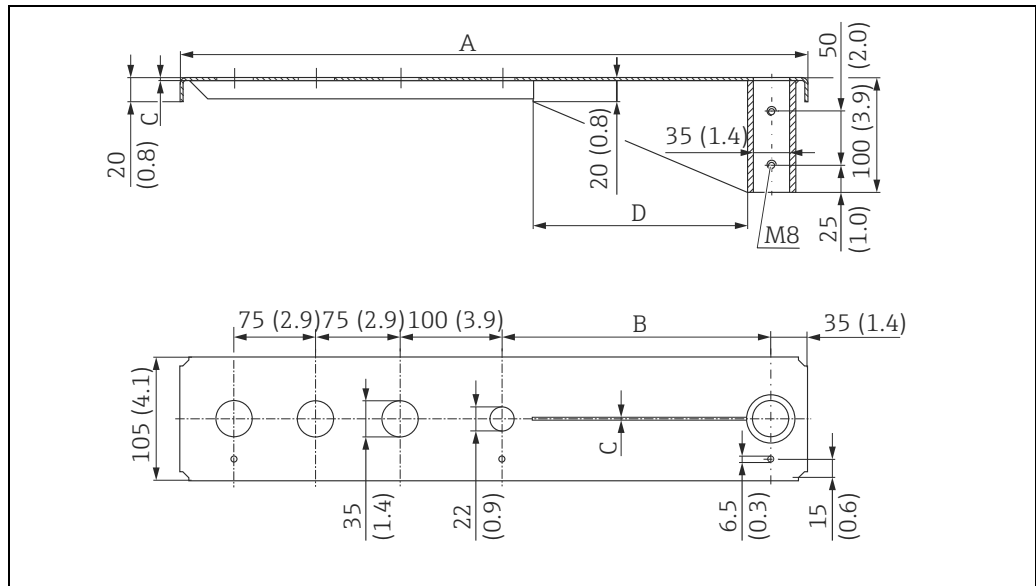

A0019592

A	B	C	D	Material	Weight	Order code
585 (23)	250 (9.84)	2 (0.08)	200 (7.87)	galvanised steel	2.1 kg (4.63 lbs)	919790-0000
				316Ti (1.4571)	2.0 kg (4.41 lbs)	919790-0001
1085 (42.7)	750 (29.5)	3 (0.12)	300 (11.8)	galvanised steel	4.5 kg (9.92 lbs)	919790-0002
				316Ti (1.4571)	4.3 kg (9.48 lbs)	919790-0003

mm (in)

- The 35 mm (1.38 in) orifices are for the sensors FDU9x.
- The 22 mm (0.87 in) orifice may be used for an external temperature sensor (e.g. FMT131).

Fixing screws are supplied.

**Mounting Frame**

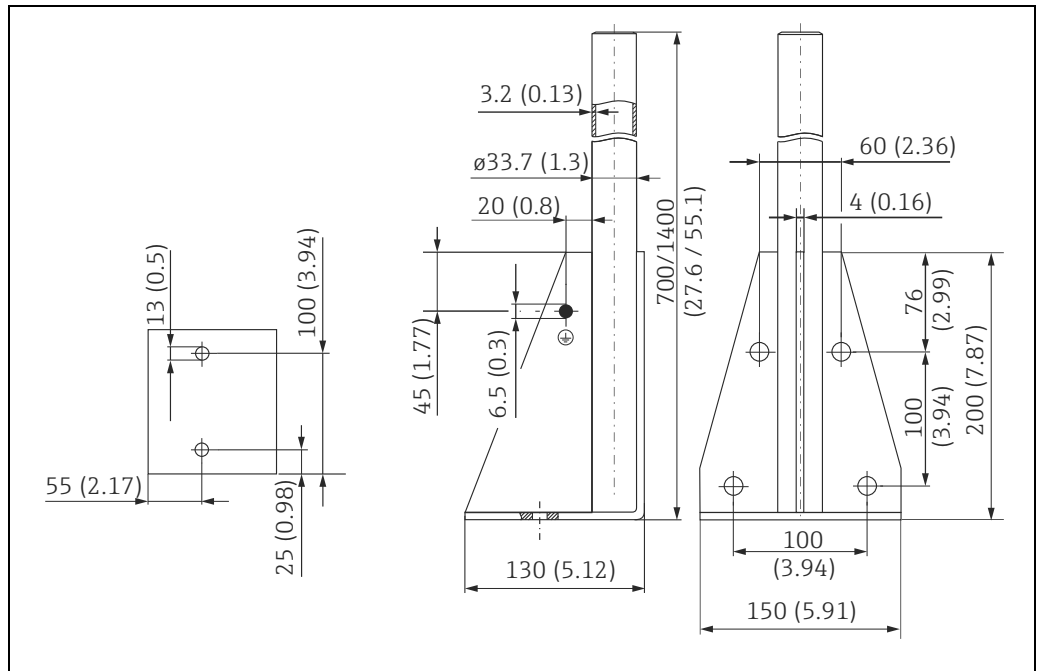

A0019279

Height	Material	Weight	Order Code
700 (27.6)	Steel, galvanized	3.2 kg (7.06 lbs)	919791-0000
700 (27.6)	316Ti (1.4571)		919791-0001
1400 (55.1)	Steel, galvanized	4.9 kg (10,08 lbs)	919791-0002
1400 (55.1)	316Ti (1.4571)		919791-0003

mm (in)

**Wall Bracket**

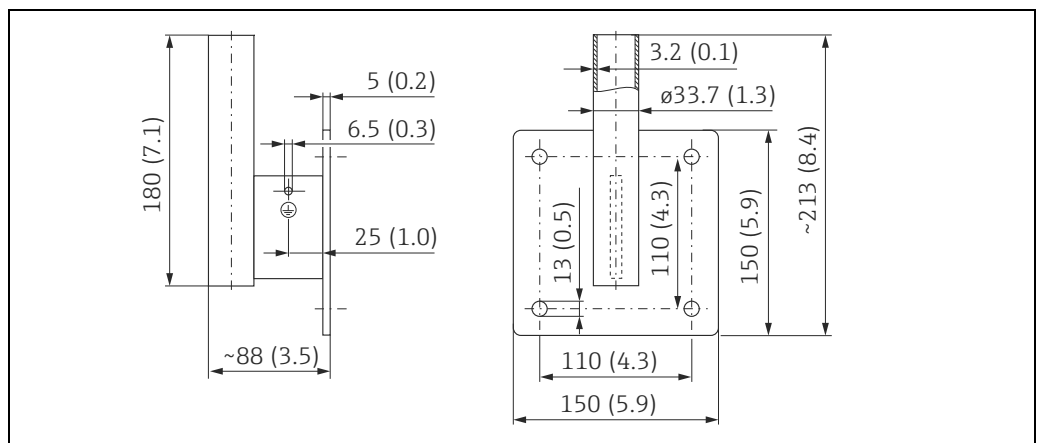

A0019350

Material	Weight	Order Code
Steel, galvanized	1.4 kg (3.09 lbs)	919792-0000
316Ti (1.4571)		919792-0001

Mounting bracket for ceiling mounting

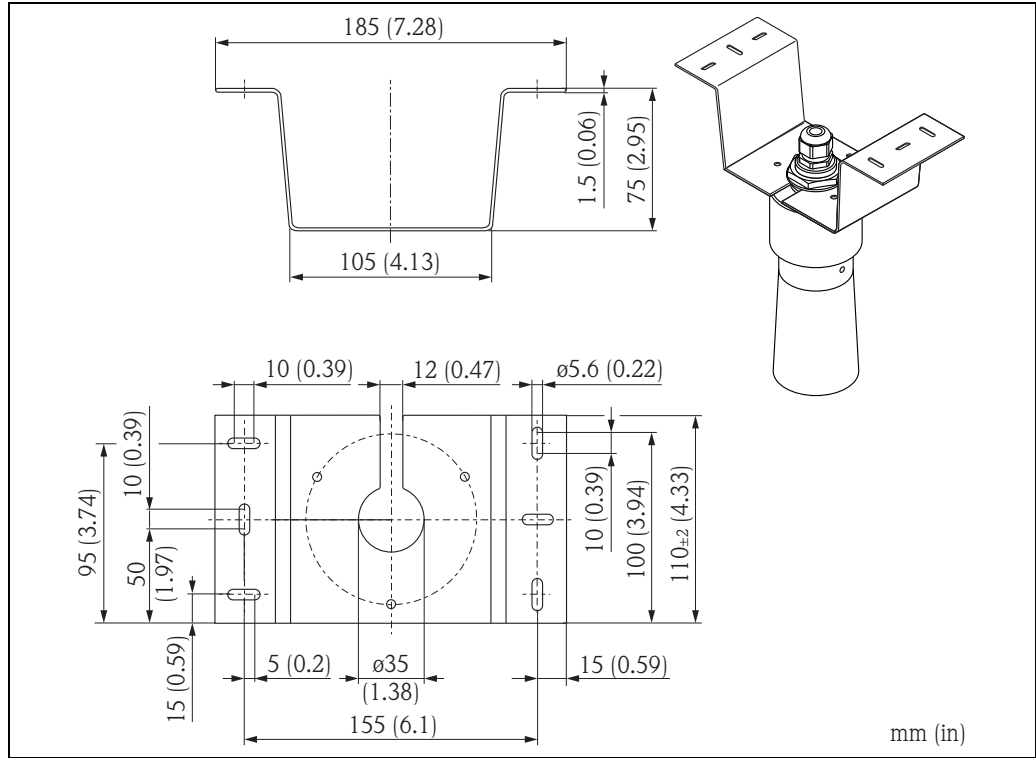

Suited for sensors:	Material	Order No.
FDU90, FDU91, FDU91F, FDU92	316L (1.4404)	71093130

**Alignment unit FAU40**

For measurements in solids, usage of the alignment unit FAU40 is recommended. It is designed for simple mounting and alignment of a FDU sensor on the product surface and can be used for zone separation in explosion hazardous areas.

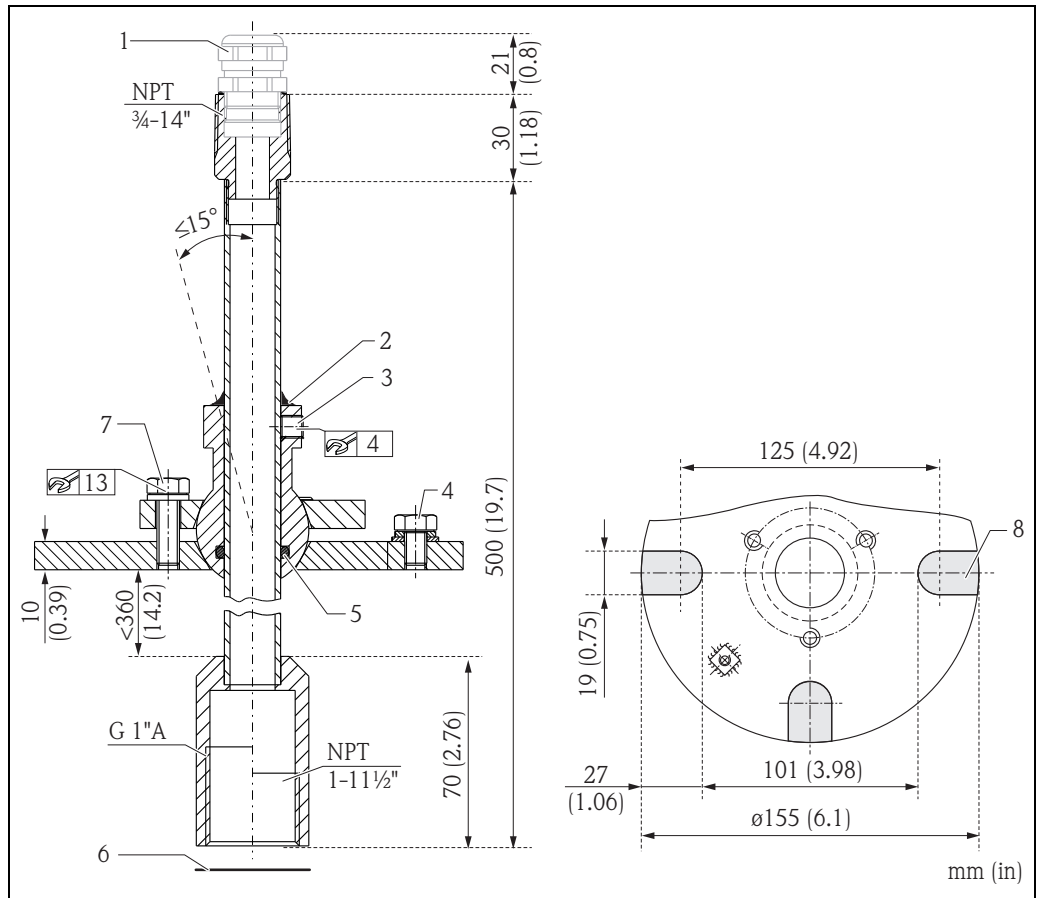

- 1 Cable gland M20x1.5 (present if selected in the product structure)
- 2 Sealant here
- 3 Two Allen screws for height adjustment [8 Nm ±2 (5.900 lbf ft)]
- 4 Ground pin
- 5 O-ring
- 6 Seal supplied with the sensor, must be used for applications in ATEX zone 20
- 7 Screw for lateral movement [18 Nm ±2 (13.276 lbf ft)]
- 8 Mounting grooves (present in the UNI flange)

The alignment unit can be rotated up to 15°. For further information see Technical Information T00179F.

**Product structure**

010	<b>Process connection (Flange)</b>	
	1	Welding flange, 304/1.4301
	2	UNI flange 2"/DN50/50, 304, max. 1.5 bar abs./22psia suitable for 2" 150lbs / DN50 PN16 / 10K 50
020	<b>Sensor connection</b>	
	S	Thread G1, cable gland M20, 304/1.4301
	G	Thread G1, cable gland M20, galvanized steel
	N	Thread NPT1, cable entry 3/4, galvanized steel
FAU40 -		product designation

**Power supply RNB130 for the FDU90/FDU91 sensor heater****Technical data**

- Primary switched-mode power supply
- Input: 100 - 240 V AC
- Output: 24 V DC connection, max. 30 V in the event of a fault
- Connection to monophased a.c. networks or to two phase conductors of three-phase supply networks  
(TN, TT or IT networks as per VDE 0100 T 300/IEC 364-3) with 100 - 240 V AC nominal voltage

For further information see Technical Information TI00120R.

**Product structure**

<b>010</b>	<b>Approvals</b>	
	A	Non-hazardous area
<b>020</b>	<b>Connection</b>	
	1	Screw strip
	3	Screw connection, power terminal block
<b>030</b>	<b>Version</b>	
	A	Standard
RNB130 -		complete product designation

**IP66 protective housing for the power supply RNB130**

Order code: 51002468

For additional information refer to Technical Information TI00080R.

## Documentation

**Technical Information****TI00397F**

Technical Information for the transmitter Prosonic S FMU90

**TI00179F**

Technical Information for the alignment unit FAU40

**Operating instructions (for transmitter FMU90)**

Depending on the instrument version, the following operating instructions are supplied with the Prosonic S FMU90:

Operating instructions	Output	Application	Instrument version
BA00288F		<ul style="list-style-type: none"> <li>■ level measurement</li> <li>■ alternating pump control</li> <li>■ screen and rake control</li> </ul>	FMU90 - *****1**** FMU90 - *****2****
BA00289F	HART	<ul style="list-style-type: none"> <li>■ flow measurement</li> <li>■ backwater and dirt detection</li> <li>■ totalizers and counters</li> </ul>	FMU90 - *2*****1**** FMU90 - *4*****1**** FMU90 - *2*****2**** FMU90 - *4*****2****
BA00292F		<ul style="list-style-type: none"> <li>■ level measurement</li> <li>■ alternating pump control</li> <li>■ screen and rake control</li> </ul>	FMU90 - *****3****
BA00293F	PROFIBUS DP	<ul style="list-style-type: none"> <li>■ flow measurement</li> <li>■ backwater and dirt detection</li> <li>■ totalizers and counters</li> </ul>	FMU90 - *2*****3**** FMU90 - *4*****3****

These operating instructions describe installation and commissioning of the respective version of the Prosonic S. It contains those functions from the operating menu, which are required for a standard measuring task. Additional functions are described in this document: Description of Instrument Functions for Prosonic S FMU90, document number BA00290F.

**Description of Instrument Functions (for transmitter FMU90)****BA00290F**

The document BA00290F contains a detailed description of **all** functions of the Prosonic S and is valid for all instrument versions.

You will find this document in the Download Area of the Endress+Hauser Internet site:

[www.endress.com](http://www.endress.com) → Download

**Safety Instructions**

The following Safety Instructions are supplied with certified versions of the sensors. If the sensors are used in hazardous areas, comply with all the specifications in these Safety Instructions.

Sensor version	Certificate	Safety Instructions
<b>ATEX</b>		
<ul style="list-style-type: none"> <li>▪ FDU90 - J...</li> <li>▪ FDU91 - J...</li> <li>▪ FDU91F - J...</li> <li>▪ FDU92 - J...</li> </ul>	<ul style="list-style-type: none"> <li>▪ II 2 G Ex ma IIC T5 Gb (FDU90)</li> <li>▪ II 2 G Ex ma IIC T6 Gb (FDU91/91F/92)</li> </ul>	XA00321F
<ul style="list-style-type: none"> <li>▪ FDU90 - E...</li> <li>▪ FDU91 - E...</li> <li>▪ FDU91F - E...</li> <li>▪ FDU92 - E...</li> <li>▪ FDU93 - J...</li> <li>▪ FDU95 - J...</li> </ul>	<ul style="list-style-type: none"> <li>▪ II 2 G Ex ma IIC T5 Gb (FDU90)</li> <li>▪ II 2 G Ex ma IIC T6 Gb (FDU91/91F/92/93/95)</li> <li>▪ II 1/2 D Ex ta/tb IIIC Txx°C Da/Db IP68</li> <li>▪ II 2 D Ex tb IIIC Txx°C Db IP68</li> </ul>	XA00322F
<ul style="list-style-type: none"> <li>▪ FDU93 - E...</li> <li>▪ FDU95 - E...</li> </ul>	<ul style="list-style-type: none"> <li>▪ II 1/2 D Ex ta/tb IIIC Txx°C Da/Db IP68</li> <li>▪ II 2 D Ex tb IIIC Txx°C Db IP68</li> </ul>	XA00323F
<b>IEC Ex</b>		
<ul style="list-style-type: none"> <li>▪ FDU90 - C...</li> <li>▪ FDU91 - C...</li> <li>▪ FDU91F - C...</li> <li>▪ FDU92 - C...</li> <li>▪ FDU93 - D...</li> <li>▪ FDU95 - D...</li> </ul>	<ul style="list-style-type: none"> <li>▪ IEC Ex ma IIC T5 Gb (FDU90)</li> <li>▪ IEC Ex ma IIC T6 Gb (FDU91/91F/92/93/95)</li> <li>▪ IEC Ex ta/tb IIIC Txx°C Da/Db IP68</li> <li>▪ IEC Ex tbIIIC Txx°C DbIP68</li> </ul>	XA00481F
<ul style="list-style-type: none"> <li>▪ FDU90 - D...</li> <li>▪ FDU91 - D...</li> <li>▪ FDU91F - D...</li> <li>▪ FDU92 - D...</li> </ul>	<ul style="list-style-type: none"> <li>▪ IEC Ex ma IIC T5 Gb (FDU90)</li> <li>▪ IEC Ex ma IIC T6 Gb (FDU91, FDU91F, FDU92)</li> </ul>	XA00482F
<ul style="list-style-type: none"> <li>▪ FDU93 - C...</li> <li>▪ FDU95 - C...</li> </ul>	<ul style="list-style-type: none"> <li>▪ IEC Ex ta/tb IIIC Txx°C Da/Db IP68</li> <li>▪ IEC Ex tbIIIC Txx°C Db IP68</li> </ul>	XA00483F



71308097

[www.addresses.endress.com](http://www.addresses.endress.com)

---