

# Technical Information

## Levelflex FMP53

Guided wave radar

### Level measurement in hygienic applications

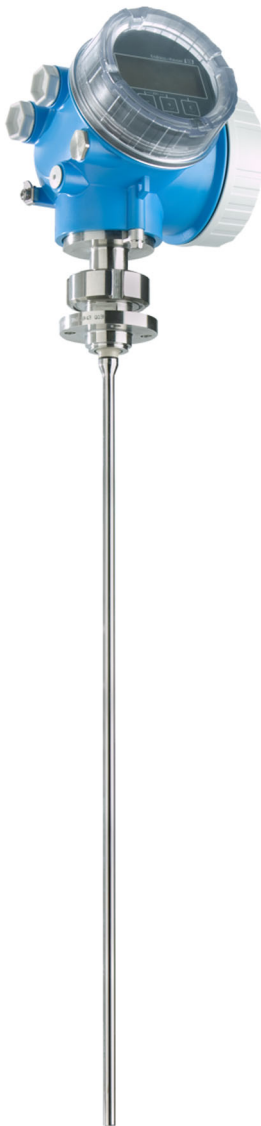

#### Application

- Rod probe
- Process connections for hygiene requirements (Tri-Clamp, 11851, 11864, NEUMO, Varivent N, SMS)
- Process temperature: -20 to +150 °C (-4 to +302 °F)
- Process pressure: -1 to +16 bar (-14.5 to +232 psi)
- Maximum measuring range: Rod 6 m (20 ft)
- Accuracy: ±2 mm (±0.08 in)
- International explosion protection certificates; WHG; EN10204-3.1; EHEDG; 3-A; CoC ASME-BPE
- Linearity protocol (3-point, 5-point)

#### Your benefits

- Reliable measurement even for changing product and process conditions
- HistoROM data management for easy commissioning, maintenance and diagnostics
- Highest reliability due to Multi-Echo Tracking
- Hardware and software developed according to IEC 61508 (up to SIL3)
- Seamless integration into control or asset management systems
- Intuitive user interface in national languages
- *Bluetooth*® wireless technology for commissioning, operation and maintenance via free iOS / Android app SmartBlue
- Easy proof test for SIL and WHG
- Heartbeat Technology™

## Table of contents

<b>Important document information</b> . . . . .	<b>4</b>	Process pressure range . . . . .	48
Symbols used . . . . .	4	Dielectric constant (DC) . . . . .	48
<b>Function and system design</b> . . . . .	<b>5</b>	<b>Mechanical construction</b> . . . . .	<b>49</b>
Measuring principle . . . . .	5	Dimensions . . . . .	49
Measuring system . . . . .	7	Probe length tolerances . . . . .	56
<b>Input</b> . . . . .	<b>9</b>	Weight . . . . .	57
Measured variable . . . . .	9	Materials: GT19 housing (plastic) . . . . .	58
Measuring range . . . . .	9	Materials: GT20 housing (die-cast aluminum, powder-coated) . . . . .	59
Blocking distance . . . . .	10	Materials: Process connection . . . . .	61
Measuring frequency spectrum . . . . .	10	Materials: Probe . . . . .	62
<b>Output</b> . . . . .	<b>11</b>	Materials: Mounting bracket . . . . .	63
Output signal . . . . .	11	Materials: Adapter and cable for remote sensor . . . . .	63
Signal on alarm . . . . .	12	Materials: Weather protection cover . . . . .	64
Linearization . . . . .	12	<b>Operability</b> . . . . .	<b>65</b>
Galvanic isolation . . . . .	12	Operating concept . . . . .	65
Protocol-specific data . . . . .	13	Local operation . . . . .	66
<b>Power supply</b> . . . . .	<b>18</b>	Operation with remote display and operating module FHX50 . . . . .	66
Terminal assignment . . . . .	18	Operation via Bluetooth® wireless technology . . . . .	67
Device plugs . . . . .	26	Remote operation . . . . .	68
Power supply . . . . .	27	Integration in tank gauging system . . . . .	71
Power consumption . . . . .	30	SupplyCare inventory management software . . . . .	72
Current consumption . . . . .	30	<b>Certificates and approvals</b> . . . . .	<b>75</b>
Power supply failure . . . . .	31	CE mark . . . . .	75
Potential equalization . . . . .	31	RoHS . . . . .	75
Terminals . . . . .	31	RCM-Tick marking . . . . .	75
Cable entries . . . . .	31	Ex approval . . . . .	75
Cable specification . . . . .	31	Dual seal according to ANSI/ISA 12.27.01 . . . . .	75
Overvoltage protection . . . . .	32	Functional safety . . . . .	75
<b>Performance characteristics</b> . . . . .	<b>33</b>	Overfill prevention . . . . .	75
Reference operating conditions . . . . .	33	Hygienic compatibility . . . . .	75
Reference accuracy . . . . .	33	ASME BPE (CoC) . . . . .	75
Resolution . . . . .	34	Pressure equipment with allowable pressure ≤ 200 bar (2 900 psi) . . . . .	76
Response time . . . . .	34	Radio approval . . . . .	76
Influence of ambient temperature . . . . .	34	Experience . . . . .	76
<b>Installation</b> . . . . .	<b>35</b>	Test, certificate . . . . .	77
Installation conditions . . . . .	35	Hard-copy product documentation . . . . .	77
<b>Operating conditions: Environment</b> . . . . .	<b>45</b>	Other standards and guidelines . . . . .	78
Ambient temperature . . . . .	45	<b>Ordering information</b> . . . . .	<b>79</b>
Ambient temperature limits . . . . .	45	Ordering information . . . . .	79
Storage temperature . . . . .	47	3-point linearity protocol . . . . .	80
Climate class . . . . .	47	5-point linearity protocol . . . . .	81
Altitude according to IEC61010-1 Ed.3 . . . . .	47	Customer-specific configuration . . . . .	82
Degree of protection . . . . .	47	Tagging (TAG) . . . . .	82
Vibration resistance . . . . .	47	<b>Application packages</b> . . . . .	<b>83</b>
Cleaning the probe . . . . .	47	Heartbeat Diagnostics . . . . .	83
Electromagnetic compatibility (EMC) . . . . .	47	Heartbeat Verification . . . . .	84
<b>Process</b> . . . . .	<b>48</b>	Heartbeat Monitoring . . . . .	85
Process temperature range . . . . .	48		

<b>Accessories</b> . . . . .	<b>86</b>
Device-specific accessories . . . . .	86
Communication-specific accessories . . . . .	92
Service-specific accessories . . . . .	93
System components . . . . .	93
<b>Supplementary documentation</b> . . . . .	<b>93</b>
Brief Operating Instructions (KA) . . . . .	93
Operating Instructions (BA) . . . . .	93
Safety Instructions (XA) . . . . .	93

## Important document information

### Symbols used

#### Safety symbols



This symbol alerts you to a dangerous situation. Failure to avoid this situation will result in serious or fatal injury.



This symbol alerts you to a dangerous situation. Failure to avoid this situation can result in serious or fatal injury.



This symbol alerts you to a dangerous situation. Failure to avoid this situation can result in minor or medium injury.



This symbol contains information on procedures and other facts which do not result in personal injury.

#### Electrical symbols



Direct current



Alternating current



Direct current and alternating current



#### Ground connection

A grounded terminal which, as far as the operator is concerned, is grounded via a grounding system.



#### Protective earth (PE)

Ground terminals that must be connected to ground prior to establishing any other connections. The ground terminals are located on the inside and outside of the device.

- Interior ground terminal; protective earth is connected to the mains supply.
- Exterior ground terminal; device is connected to the plant grounding system.

#### Symbols for certain types of information and graphics

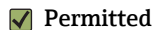

Procedures, processes or actions that are permitted

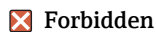

Procedures, processes or actions that are forbidden



Indicates additional information



Reference to documentation



Reference to graphic



Notice or individual step to be observed

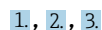

Series of steps



Result of a step

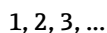

Item numbers

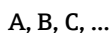

Views



#### Temperature resistance of the connection cables

Specifies the minimum value of the temperature resistance of the connection cables

## Function and system design

### Measuring principle

#### General principles

The Levelflex is a "downward-looking" measuring system that functions according to the time-of-flight method (ToF). The distance from the reference point to the product surface is measured. High-frequency pulses are injected to a probe and led along the probe. The pulses are reflected by the product surface, received by the electronic evaluation unit and converted into level information. This method is also known as TDR (time domain reflectometry).

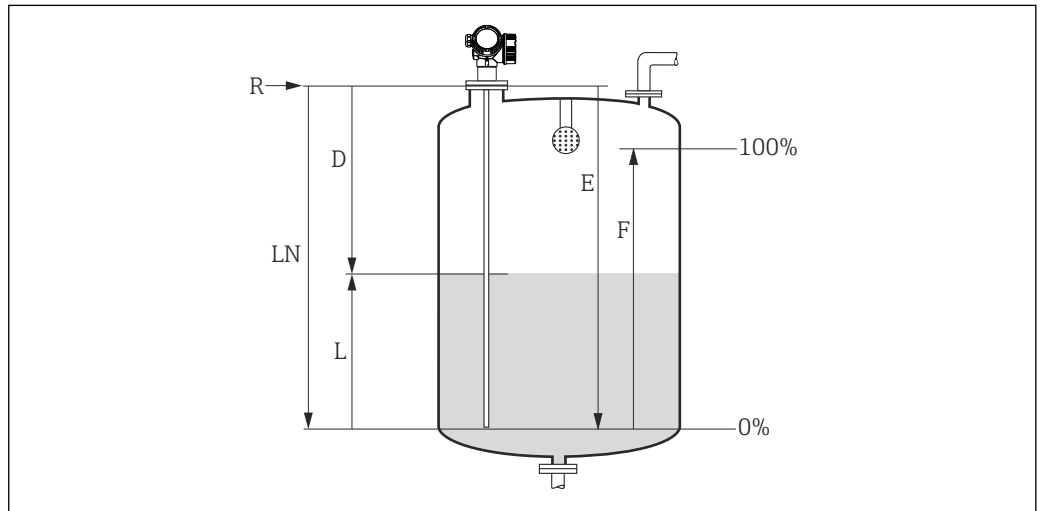

1 Parameters for level measurement with guided wave radar

- LN Probe length
- D Distance
- L Level
- R Reference point of measurement
- E Empty calibration (= zero)
- F Full calibration (= span)

**i** The reference point **R** of the measurement is located at the process connection.

**Dielectric constant**

The dielectric constant (DC) of the medium directly affects the degree of reflection of the high-frequency pulses. In the case of large DC values, such as with water or ammonia, there is strong pulse reflection while, in the case of low DC values, such as with hydrocarbons, pulse reflection is weak.

**Input**

The reflected pulses are transmitted from the probe to the electronics. Here, a microprocessor evaluates the signals and identifies the level echo which was caused by the reflection of the high-frequency pulses at the product surface. This clear signal detection system benefits from over 30 years of experience with pulse time-of-flight procedures that have gone into the development of the PulseMaster® software.

The distance  $D$  to the product surface is proportional to the time of flight  $t$  of the impulse:

$$D = c \cdot t/2,$$

with  $c$  being the speed of light.

Based on the known empty distance  $E$ , the level  $L$  is calculated:

$$L = E - D$$

The Levelflex has functions for interference echo suppression that can be activated by the user. They guarantee that interference echoes from internal fixtures and struts, for example, are not interpreted as level echoes.

**Output**

The Levelflex is preadjusted at the factory to the probe length ordered so that in most cases only the application parameters that automatically adapt the device to the measuring conditions need to be entered. For models with a current output, the factory adjustment for zero point  $E$  and span  $F$  is 4 mA and 20 mA, for digital outputs and the display module 0 % and 100 %. A linearization function with max. 32 points, based on a table entered either manually or semi-automatically, can be activated locally or remotely. This function allows the level to be converted into units of volume or mass, for example.

**Life cycle of the product**

**Design**

- Universal measuring principle
- Measurement is unaffected by product properties
- Hardware and software developed according to SIL IEC 61508
- Genuine, direct interface measurement

**Procurement**

- As the global market leader in level measurement, Endress+Hauser guarantees the security of your investment
- Worldwide support and service

**Installation**

- No special tools are required
- Protection against reverse polarity
- Modern, detachable terminals
- Main electronics protected by a separate connection compartment

**Commissioning**

- Fast, menu-guided commissioning in just 6 steps
- Plain text display in local language reduces the risk of error or confusion
- Direct local access to all parameters
- Printed Brief Operating Instructions in the device onsite

**Operation**

- Multi-echo tracking: Reliable measurement thanks to self-learning echo search algorithms taking into account the short-term and long-term history and plausibility of the detected signals to suppress interference echoes.
- In accordance with NAMUR NE107

**Maintenance**

- HistoROM: Data backup for device settings and measured values
- Exact device and process diagnostics to assist fast decisions with clear information regarding remedial action
- Intuitive, menu-guided operating concept in local language saves costs for training, maintenance and operation
- Cover of the electronics compartment can also be opened in the hazardous area

**Retirement**

- Order code translation for subsequent models
- RoHS-compliant (Restriction of certain Hazardous Substances), unleaded soldering of electronic components
- Environmentally friendly recycling approach

---

**Measuring system**

**Probe selection**

*FMP53*

For level measurement in liquids

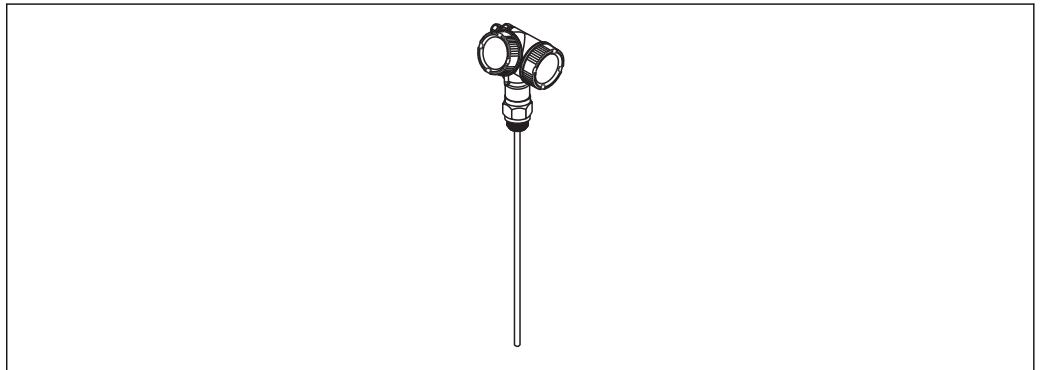

2 Rod probe

A0011387

**Rod probe**

- Maximum probe length
  - 4 m (13 ft); inseparable rod probes
  - 6 m (20 ft); separable rod probes
- Material:
  - 316L, Ra<0.76 µm (30 µin)
  - 316L, electropolished Ra<0.38 µm (15 µin)
-  ▪ Connectable reference probe
  - Calibration kit FMP53 (order no.: 71041382)
  - Autoclavable
    - Protective cover FMP53 (order no.: 71041379)

## Input

**Measured variable** The measured variable is the distance between the reference point and the product surface.  
The level is calculated based on "E", the empty distance entered.  
Optionally, the level can be converted to other variables (volume, mass) by linearization (32 points).

**Measuring range** The following table describes the media groups and the possible measuring range as a function of the media group.

Levelflex FMP53			
Media group	$\epsilon_r$	Typical liquids	Measuring range
			Rod probes
1	1.4 to 1.6	Liquefied gases, e.g. N <sub>2</sub> , CO <sub>2</sub>	On request
2	1.6 to 1.9	<ul style="list-style-type: none"> <li>▪ Liquefied gas, e.g. propane</li> <li>▪ Solvents</li> <li>▪ Freon</li> <li>▪ Palm oil</li> </ul>	One-piece: 4 m (13 ft) Separable: 6 m (20 ft)
3	1.9 to 2.5	Mineral oils, fuels	One-piece: 4 m (13 ft) Separable: 6 m (20 ft)
4	2.5 to 4	<ul style="list-style-type: none"> <li>▪ Benzene, styrene, toluene</li> <li>▪ Furan</li> <li>▪ Naphthalene</li> </ul>	One-piece: 4 m (13 ft) Separable: 6 m (20 ft)
5	4 to 7	<ul style="list-style-type: none"> <li>▪ Chlorobenzene, chloroform</li> <li>▪ Nitrocellulose lacquers</li> <li>▪ Isocyanate, aniline</li> </ul>	One-piece: 4 m (13 ft) Separable: 6 m (20 ft)
6	> 7	<ul style="list-style-type: none"> <li>▪ Aqueous solutions</li> <li>▪ Alcohols</li> <li>▪ Acids, alkalis</li> </ul>	One-piece: 4 m (13 ft) Separable: 6 m (20 ft)



The formation of buildup, particularly of moist products, can reduce the maximum possible measuring range.

**Blocking distance**

The upper blocking distance (= UB) is the minimum distance from the reference point of the measurement (mounting flange) to the maximum level.

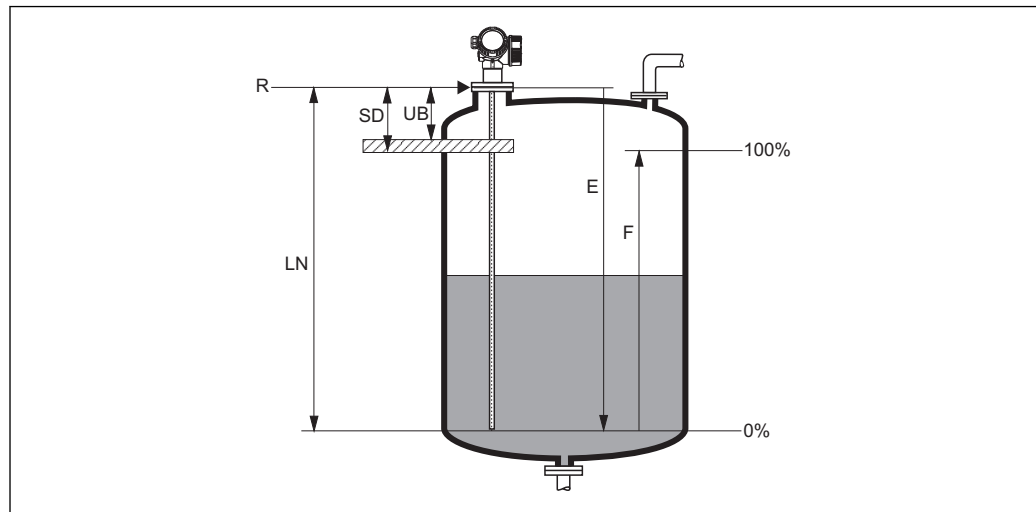

A0011279

**3** Definition of blocking distance and safety distance

*R* Reference point of measurement

*LN* Probe length

*UB* Upper blocking distance

*E* Empty calibration (= zero)

*F* Full calibration (= span)

*SD* Safety distance

Blocking distance (factory setting):

For rod probes up to 6 m (20 ft): 200 mm (8 in)

**i** The specified blocking distances are factory-preset on delivery. These settings can be changed depending on the application.

If a spray head is used, the blocking distance may not be set to less than 50 mm (2 in), however.

For rod probes, the blocking distance can generally be reduced to 100 mm (4 in) for media with  $DC > 7$ .

No blocking distance applies for applications in a bypass/stilling well.

A reliable measurement cannot be guaranteed within the blocking distance.

**i** A safety distance *SD* can be defined in addition to the blocking distance. The device generates a warning if the level rises to enter this safety distance.

**Measuring frequency spectrum**

100 MHz to 1.5 GHz

## Output

### Output signal

#### HART

- Signal coding:  
FSK  $\pm 0.5$  mA over current signal
- Data transmission rate:  
1 200 Bit/s
- Galvanic isolation:  
Yes

#### Bluetooth® wireless technology

- Device version:  
Order code 610 "Accessory mounted", option NF "Bluetooth"
- Operation / configuration:  
Via the *SmartBlue* app
- Range under reference conditions:  
> 10 m (33 ft)
- Encryption:  
Encrypted communication and password encryption prevent incorrect operation by unauthorized persons

#### PROFIBUS PA

- Signal coding:  
Manchester Bus Powered (MBP)
- Data transmission rate:  
31.25 kBit/s, Voltage mode
- Galvanic isolation:  
Yes

#### FOUNDATION Fieldbus

- Signal coding:  
Manchester Bus Powered (MBP)
- Data transmission rate:  
31.25 kBit/s, Voltage mode
- Galvanic isolation:  
Yes

#### Switch output



For HART devices, the switch output is available as an option.

- Function:  
Open collector switch output
- Switching behavior:  
Binary (conductive or non-conductive), switches when the programmable switch-on point/switch-off point is reached
- Failure mode:  
Non-conductive
- Electrical connection data:  
 $U = 16$  to  $35$  V<sub>DC</sub>,  $I = 0$  to  $40$  mA
- Internal resistor:  
 $R_i < 880 \Omega$   
The voltage drop at this internal resistor must be taken into account when planning the configuration. For example, the resulting voltage at a connected relay must be sufficient to switch the relay.
- Insulation voltages:  
Floating, insulation voltage  $1\,350$  V<sub>DC</sub> in relation to power supply and  $500$  V<sub>AC</sub> ground
- Switch point:  
User-programmable, separate for switch-on point and switch-off point
- Switching delay:  
User-programmable in the  $0$  to  $100$  s range, separate for switch-on point and switch-off point

- Scan rate:  
Corresponds to the measuring cycle
- Signal source / device variables:
  - Level linearized
  - Distance
  - Terminal voltage
  - Electronic temperature
  - Relative echo amplitude
  - Diagnostic values, advanced diagnostic blocks
  - Only for active interface measurement
- Number of switch cycles:  
Unlimited

**Signal on alarm**

Depending on the interface, failure information is displayed as follows:

- Current output
  - Choice of failure mode (in accordance with NAMUR Recommendation NE 43):  
Minimum alarm: 3.6 mA  
Maximum alarm (= factory setting): 22 mA
  - Failure mode with user-configurable value: 3.59 to 22.5 mA
- Local display
  - Status signal (as per NAMUR Recommendation NE 107)
  - Plain text display
- Operating tool via digital communication (HART, PROFIBUS PA, FOUNDATION Fieldbus) or service interface (CDI)
  - Status signal (as per NAMUR Recommendation NE 107)
  - Plain text display

**Linearization**

The device's linearization function allows the user to convert the measured value to any length or volume units. Linearization tables for calculating the volume in cylindrical vessels are preprogrammed into the device. Other tables of up to 32 value pairs can be entered manually or semi-automatically.

**Galvanic isolation**

All circuits for the outputs are galvanically isolated from each other.

**Protocol-specific data**

**HART**

Manufacturer ID	17 (0x11)
Device type ID	0x1122
HART specification	7.0
Device description files (DTM, DD)	Information and files under: <ul style="list-style-type: none"> <li>▪ <a href="http://www.endress.com">www.endress.com</a></li> <li>▪ <a href="http://www.fieldcommgroup.org">www.fieldcommgroup.org</a></li> </ul>
HART load	min. 250 Ω
HART device variables	<p>The measured values can be freely assigned to the device variables.</p> <p><b>Measured values for PV (primary variable)</b></p> <ul style="list-style-type: none"> <li>▪ Level linearized</li> <li>▪ Distance</li> <li>▪ Electronic temperature</li> <li>▪ Relative echo amplitude</li> </ul> <p><b>Measured values for SV, TV, QV (second, third and fourth variable)</b></p> <ul style="list-style-type: none"> <li>▪ Level linearized</li> <li>▪ Distance</li> <li>▪ Terminal voltage</li> <li>▪ Electronic temperature</li> <li>▪ Absolute echo amplitude</li> <li>▪ Relative echo amplitude</li> <li>▪ Calculated <math>\epsilon_r</math> value</li> </ul>
Supported functions	<ul style="list-style-type: none"> <li>▪ Burst mode</li> <li>▪ Additional transmitter status</li> </ul>

**Wireless HART data**

Minimum starting voltage	17.5 V
Start-up current	4 mA
Starting time	80 s
Minimum operating voltage	17.5 V
Multidrop current	4.0 mA
Time for connection setup	30 s

**PROFIBUS PA**

Manufacturer ID	17 (0x11)
Ident number	0x1558
Profile version	3.02
GSD file	Information and files under:
GSD file version	<ul style="list-style-type: none"> <li>▪ <a href="http://www.endress.com">www.endress.com</a></li> <li>▪ <a href="http://www.profibus.org">www.profibus.org</a></li> </ul>
Output values	<p><b>Analog Input:</b></p> <ul style="list-style-type: none"> <li>▪ Level linearized</li> <li>▪ Distance</li> <li>▪ Terminal voltage</li> <li>▪ Electronic temperature</li> <li>▪ Absolute echo amplitude</li> <li>▪ Relative echo amplitude</li> <li>▪ Calculated <math>\epsilon_r</math> value</li> </ul> <p><b>Digital Input:</b></p> <ul style="list-style-type: none"> <li>▪ Extended diagnostic blocks</li> <li>▪ Status output PFS Block</li> </ul>
Input values	<p><b>Analog Output:</b></p> <ul style="list-style-type: none"> <li>▪ Analog value from PLC (for sensor block, external pressure and temperature)</li> <li>▪ Analog value from PLC to be indicated on the display</li> </ul> <p><b>Digital Output:</b></p> <ul style="list-style-type: none"> <li>▪ Extended diagnostic block</li> <li>▪ Level Limiter</li> <li>▪ Sensor Block Measurement On</li> <li>▪ Sensor Block Save History On</li> <li>▪ Status output</li> </ul>
Supported functions	<ul style="list-style-type: none"> <li>▪ Identification &amp; Maintenance Simple device identification via control system and nameplate</li> <li>▪ Automatic Ident Number Adoption GSD compatibility mode with predecessor Levelflex M FMP4x</li> <li>▪ Physical Layer Diagnostics Installation check of the PROFIBUS segment and the Levelflex M FMP4x using terminal voltage and message monitoring</li> <li>▪ PROFIBUS upload/download Reading and writing parameters is up to ten times faster with PROFIBUS upload/download</li> <li>▪ Condensed status Simplest and self-explanatory diagnostic information by categorizing diagnostic messages that occur</li> </ul>

**FOUNDATION Fieldbus**

Manufacturer ID	0x452B48
Device type	0x1028
Device revision	0x01
DD revision	Information and files under:
CFF revision	<ul style="list-style-type: none"> <li>▪ <a href="http://www.endress.com">www.endress.com</a></li> <li>▪ <a href="http://www.fieldcommgroup.org">www.fieldcommgroup.org</a></li> </ul>
Device Tester Version (ITK version)	6.0.1
ITK Test Campaign Number	IT085300
Link Master capability (LAS)	Yes
Choice of "Link Master" and "Basic Device"	Yes; Factory setting: Basic Device
Node address	Factory setting: 247 (0xF7)

Supported functions	The following methods are supported: <ul style="list-style-type: none"> <li>■ Restart</li> <li>■ ENP Restart</li> <li>■ Setup</li> <li>■ Linearization</li> <li>■ Self Check</li> </ul>
<b>Virtual Communication Relationships (VCRs)</b>	
Number of VCRs	44
Number of link objects in VFD	50
Permanent entries	1
Client VCRs	0
Server VCRs	10
Source VCRs	43
Sink VCRs	0
Subscriber VCRs	43
Publisher VCRs	43
<b>Device Link Capabilities</b>	
Slot time	4
Min. delay between PDU	8
Max. response delay	20

*Transducer Blocks*

<b>Block</b>	<b>Contents</b>	<b>Output values</b>
Setup Transducer Block	Contains all the parameters for standard commissioning	<ul style="list-style-type: none"> <li>■ Level or volume (channel 1) (depending on the block configuration)</li> <li>■ Distance (channel 2)</li> </ul>
Advanced Setup Transducer Block	Contains all the parameters for more accurate measurement configuration	No output values
Display Transducer Block	Contains parameters to configure the onsite display	No output values
Diagnostic Transducer Block	Contains diagnostic information	No output values
Advanced Diagnostic Transducer Block	Contains parameters for advanced diagnostics	No output values
Expert Configuration Transducer Block	Contains parameters that require the user to have in-depth knowledge of the operation of the device in order to configure the parameters appropriately	No output values
Expert Information Transducer Block	Contains parameters that provide information about the state of the device	No output values
Service Sensor Transducer Block	Contains parameters that can only be accessed by Endress+Hauser Service	No output values
Service Information Transducer Block	Contains parameters that provide Endress+Hauser Service with information about the state of the device	No output values
Data Transfer Transducer Block	Contains parameters for backing up the device configuration in the display module and for writing the saved configuration to the device. Access to these parameters is reserved for Endress+Hauser Service.	No output values

## Function blocks

Block	Contents	Number of permanent blocks	Number of instantiatable blocks	Execution time	Functionality
Resource Block	The Resource Block contains all the data that uniquely identify the device. It is an electronic version of a nameplate of the device.	1	0	-	Enhanced
Analog Input Block	The AI Block receives the measuring data from the Sensor Block (selectable via a channel number), and makes the data available to other blocks at its output.	2	3	25 ms	Enhanced
Discrete Input Block	The Discrete Input Block receives a discrete value (e.g. indicator that measuring range has been exceeded) and makes the value available for other blocks at the output.	1	2	20 ms	Standard
Multiple Analog Output Block	The Multiple Analog Output Block is used to transmit analog values from the bus to the device.	1	0	20 ms	Standard
Multiple Discrete Output Block	The Multiple Discrete Output Block is used to transmit discrete values from the bus to the device.	1	0	20 ms	Standard
PID Block	The PID Block is used as a proportional-integral-derivative controller and can be used universally for closed-loop-control in the field. It enables cascade mode and feedforward control.	1	1	25 ms	Standard
Arithmetic Block	The Arithmetic Block is designed to permit simple use of popular measurement math functions. The user does not have to know how to write equations. The math algorithm is selected by name, chosen by the user for the function to be performed.	1	1	25 ms	Standard
Signal Characterizer Block	The Signal Characterizer Block has two sections, each with an output value that is a non-linear function of the input value. The non-linear function is generated by a single look-up table with 21 arbitrary x-y pairs.	1	1	25 ms	Standard
Input Selector Block	The Input Selector Block facilitates the selection of up to four inputs and generates an output value based on the configured action. This block normally receives its inputs from AI Blocks. The block enables the selection of maximum, minimum, average and 'first good' values.	1	1	25 ms	Standard

Block	Contents	Number of permanent blocks	Number of instantiatable blocks	Execution time	Functionality
Integrator Block	The Integrator Block integrates a variable as a function of the time or accumulates the counts from a Pulse Input Block. The Block can be used as a totalizer that totalizes until a reset, or as a batch totalizer whereby the integrated value is compared against a target value generated before or during the control routine and generates a binary signal when the target value is reached.	1	1	25 ms	Standard
Analog Alarm Block		1	1	25 ms	Standard

 Up to 20 blocks can be instantiated in the device altogether, including the blocks already instantiated.

# Power supply

## Terminal assignment

### Terminal assignment 2-wire: 4-20 mA HART

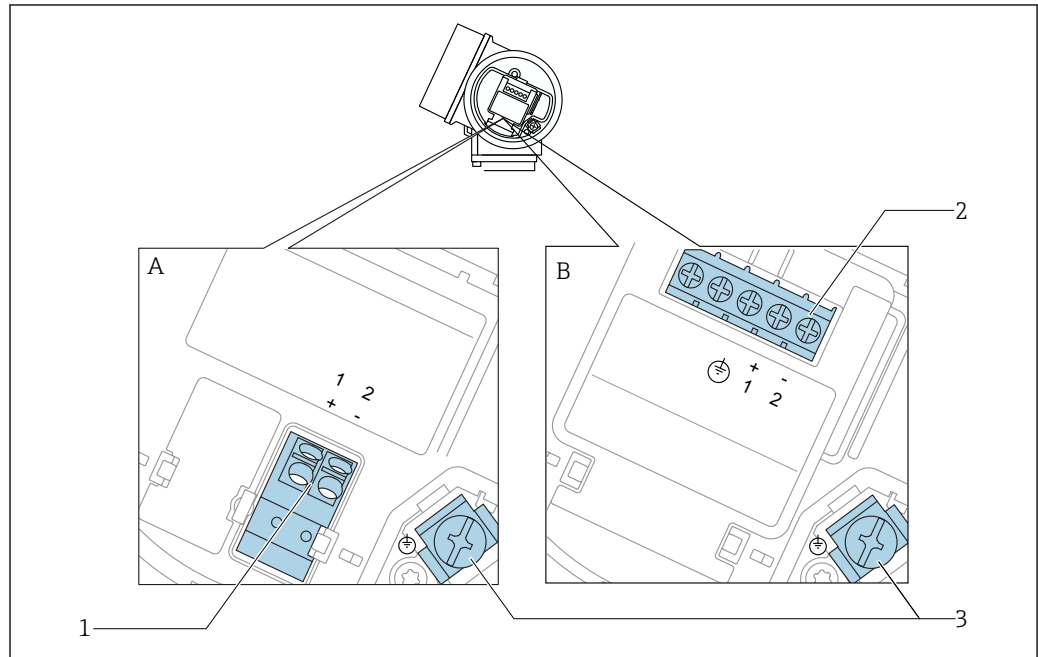

A0036498

4 Terminal assignment 2-wire: 4-20 mA HART

A Without integrated overvoltage protection

B With integrated overvoltage protection

1 Connection 4-20 mA HART passive: terminals 1 and 2, without integrated overvoltage protection

2 Connection 4-20 mA HART passive: terminals 1 and 2, with integrated overvoltage protection

3 Terminal for cable screen

### Block diagram 2-wire: 4-20 mA HART

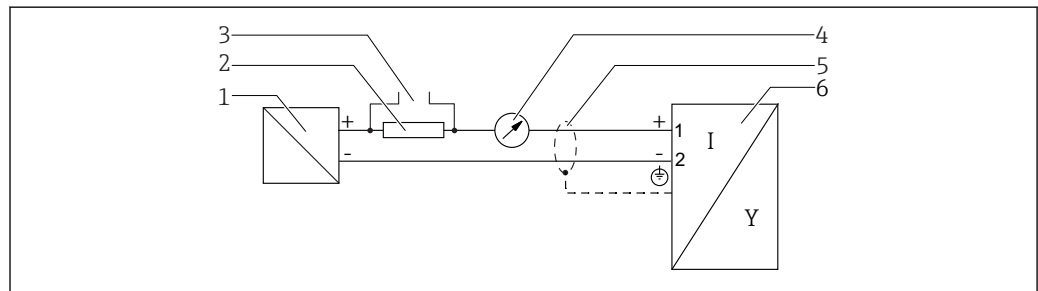

A0036499

5 Block diagram 2-wire: 4-20 mA HART

1 Active barrier with power supply (e.g. RN221N); observe terminal voltage

2 HART communication resistor ( $\geq 250 \Omega$ ); observe maximum load

3 Connection for Commubox FXA195 or FieldXpert SFX350/SFX370 (via VIATOR Bluetooth modem)

4 Analog display device; observe maximum load

5 Cable screen; observe cable specification

6 Measuring device

**Terminal assignment 2-wire: 4-20 mA HART, switch output**

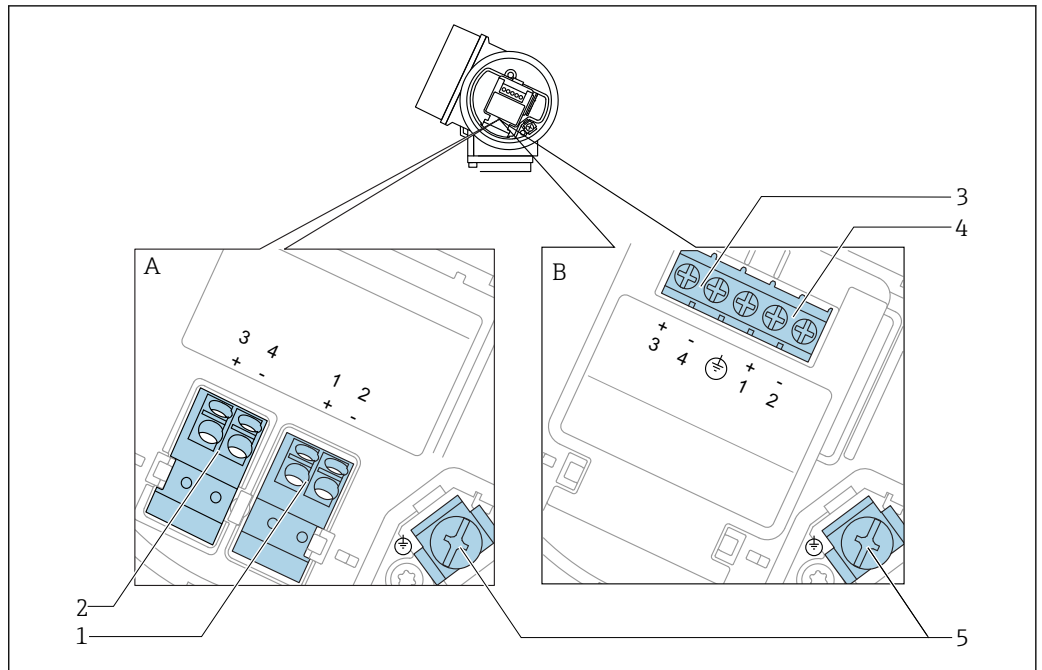

A0036500

**6** Terminal assignment 2-wire: 4-20 mA HART, switch output

A Without integrated overvoltage protection

B With integrated overvoltage protection

1 Connection 4-20 mA HART passive: terminals 1 and 2, without integrated overvoltage protection

2 Connection switch output (Open Collector): terminals 3 and 4, without integrated overvoltage protection

3 Connection switch output (Open Collector): terminals 3 and 4, with integrated overvoltage protection

4 Connection 4-20 mA HART passive: terminals 1 and 2, with integrated overvoltage protection

5 Terminal for cable screen

**Block diagram 2-wire: 4-20 mA HART, switch output**

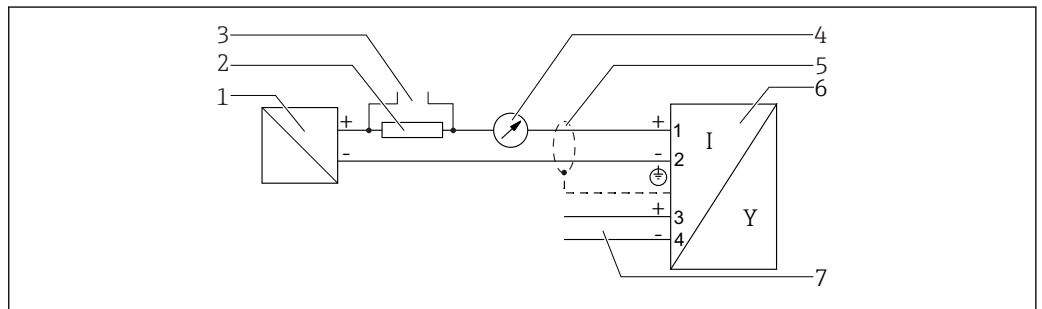

A0036501

**7** Block diagram 2-wire: 4-20 mA HART, switch output

1 Active barrier with power supply (e.g. RN221N); observe terminal voltage

2 HART communication resistor ( $\geq 250 \Omega$ ); observe maximum load

3 Connection for Commubox FXA195 or FieldXpert SFX350/SFX370 (via VIATOR Bluetooth modem)

4 Analog display device; observe maximum load

5 Cable screen; observe cable specification

6 Measuring device

7 Switch output (Open Collector)

**Terminal assignment 2-wire: 4-20 mA HART, 4-20 mA**

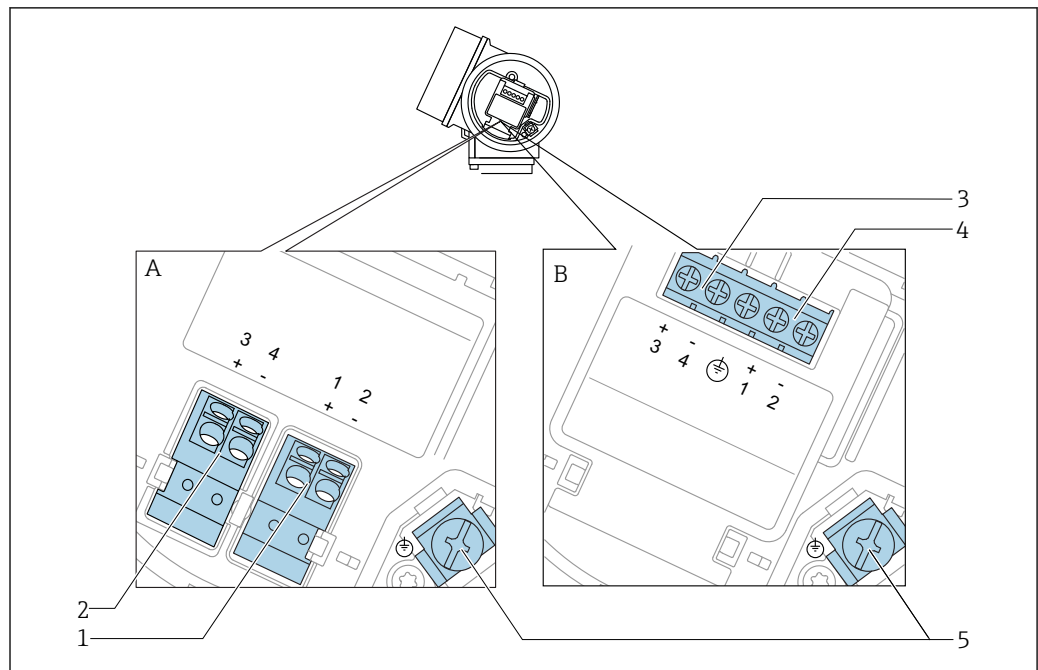

A0036500

**8** Terminal assignment 2-wire: 4-20 mA HART, 4-20 mA

A Without integrated overvoltage protection

B With integrated overvoltage protection

1 Connection current output 1, 4-20 mA HART passive: terminals 1 and 2, without integrated overvoltage protection

2 Connection current output 2, 4-20 mA: terminals 3 and 4, without integrated overvoltage protection

3 Connection current output 2, 4-20 mA: terminals 3 and 4, with integrated overvoltage protection

4 Connection current output 1, 4-20 mA HART passive: terminals 1 and 2, with integrated overvoltage protection

5 Terminal for cable screen

**Block diagram 2-wire: 4-20 mA HART, 4-20 mA**

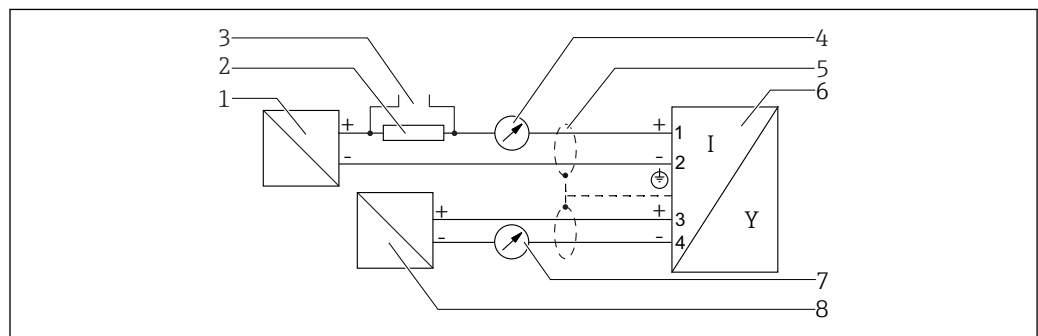

A0036502

**9** Block diagram 2-wire: 4-20 mA HART, 4-20 mA

1 Active barrier with power supply (e.g. RN221N); observe terminal voltage

2 HART communication resistor ( $\geq 250 \Omega$ ); observe maximum load

3 Connection for Commubox FXA195 or FieldXpert SFX350/SFX370 (via VIATOR Bluetooth modem)

4 Analog display device; observe maximum load

5 Cable screen; observe cable specification

6 Measuring device

7 Analog display device; observe maximum load

8 Active barrier with power supply (e.g. RN221N), current output 2; observe terminal voltage

**Terminal assignment 4-wire: 4-20 mA HART (10.4 to 48 V<sub>DC</sub>)**

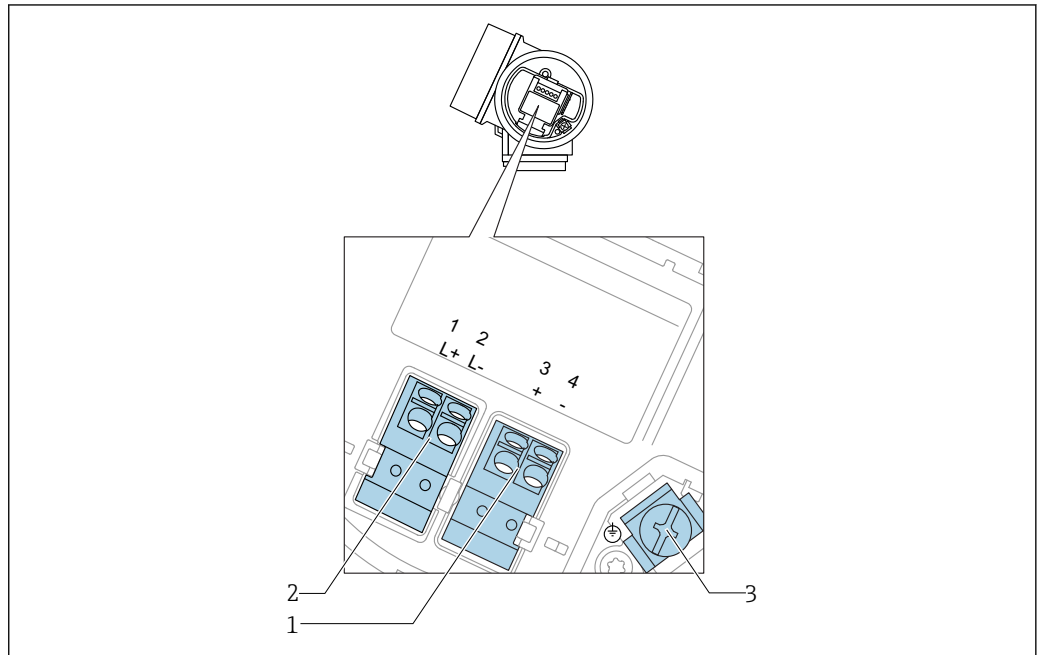

A0036516

10 Terminal assignment 4-wire: 4-20 mA HART (10.4 to 48 V<sub>DC</sub>)

- 1 Connection 4-20 mA HART (active): terminals 3 and 4
- 2 Connection supply voltage: terminals 1 and 2
- 3 Terminal for cable screen

**Block diagram 4-wire: 4-20 mA HART (10.4 to 48 V<sub>DC</sub>)**

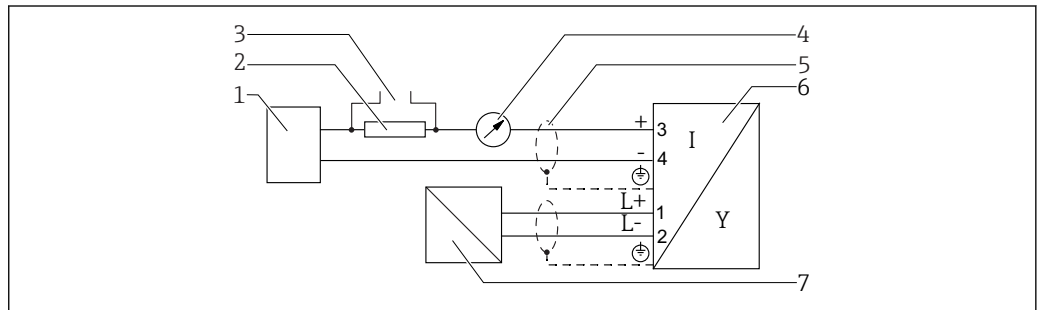

A0036526

11 Block diagram 4-wire: 4-20 mA HART (10.4 to 48 V<sub>DC</sub>)

- 1 Evaluation unit, e.g. PLC
- 2 HART communication resistor ( $\geq 250 \Omega$ ); observe maximum load
- 3 Connection for Commubox FXA195 or FieldXpert SFX350/SFX370 (via VIATOR Bluetooth modem)
- 4 Analog display device; observe maximum load
- 5 Cable screen; observe cable specification
- 6 Measuring device
- 7 Supply voltage; observe terminal voltage, observe cable specification

### Terminal assignment 4-wire: 4-20 mA HART (90 to 253 V<sub>AC</sub>)

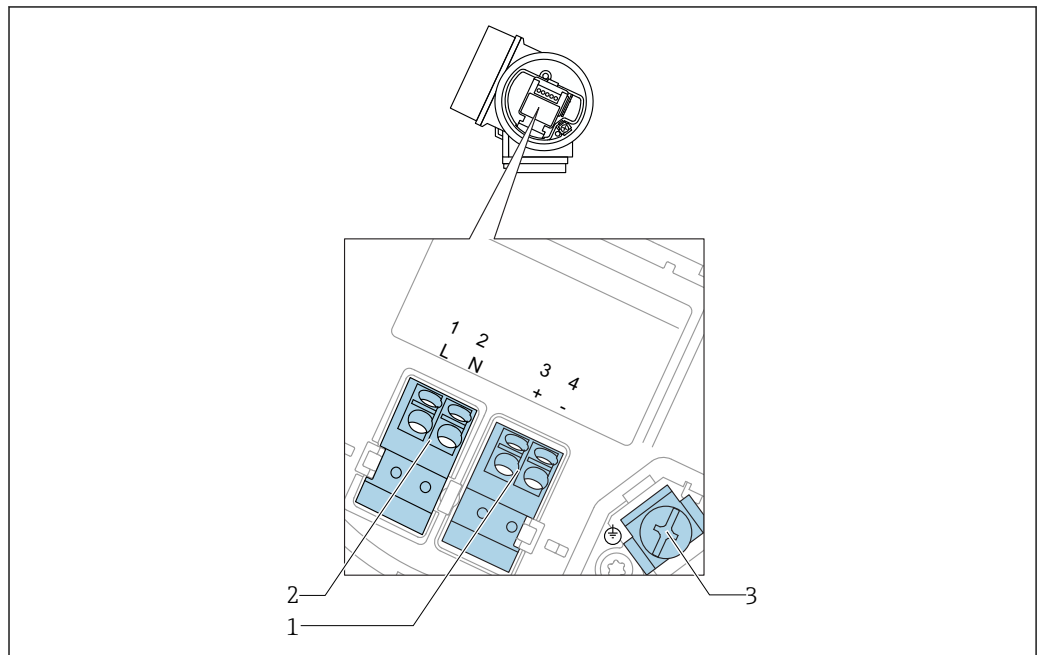

A0036519

12 Terminal assignment 4-wire: 4-20 mA HART (90 to 253 V<sub>AC</sub>)

- 1 Connection 4-20 mA HART (active): terminals 3 and 4
- 2 Connection supply voltage: terminals 1 and 2
- 3 Terminal for cable screen

#### **CAUTION**

##### To ensure electrical safety:

- ▶ Do not disconnect the protective connection.
- ▶ Disconnect the supply voltage before disconnecting the protective earth.

- i** Connect protective earth to the internal ground terminal (3) before connecting the supply voltage. If necessary, connect the potential matching line to the external ground terminal.
- i** In order to ensure electromagnetic compatibility (EMC): Do **not** only ground the device via the protective earth conductor of the supply cable. Instead, the functional grounding must also be connected to the process connection (flange or threaded connection) or to the external ground terminal.
- i** An easily accessible power switch must be installed in the proximity of the device. The power switch must be marked as a disconnect for the device (IEC/EN61010).

**Block diagram 4-wire: 4-20 mA HART (90 to 253 V<sub>AC</sub>)**

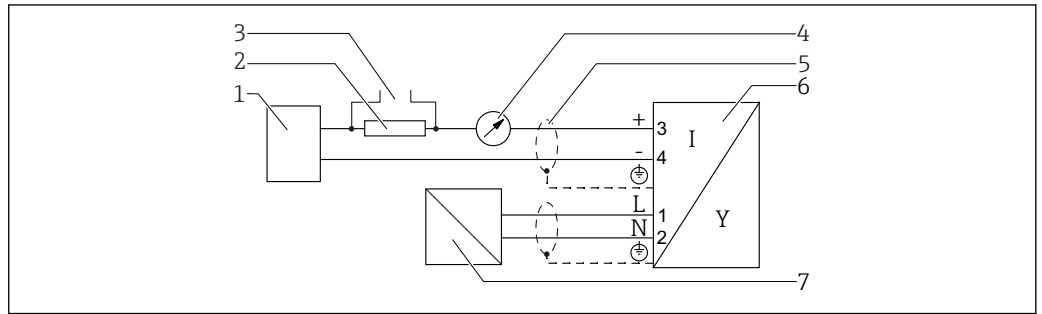

A0036527

13 Block diagram 4-wire: 4-20 mA HART (90 to 253 V<sub>AC</sub>)

- 1 Evaluation unit, e.g. PLC
- 2 HART communication resistor ( $\geq 250 \Omega$ ); observe maximum load
- 3 Connection for Commubox FXA195 or FieldXpert SFX350/SFX370 (via VIATOR Bluetooth modem)
- 4 Analog display device; observe maximum load
- 5 Cable scree; observe cable specification
- 6 Measuring device
- 7 Supply voltage; observe terminal voltage, observe cable specification

**Terminal assignment PROFIBUS PA / FOUNDATION Fieldbus**

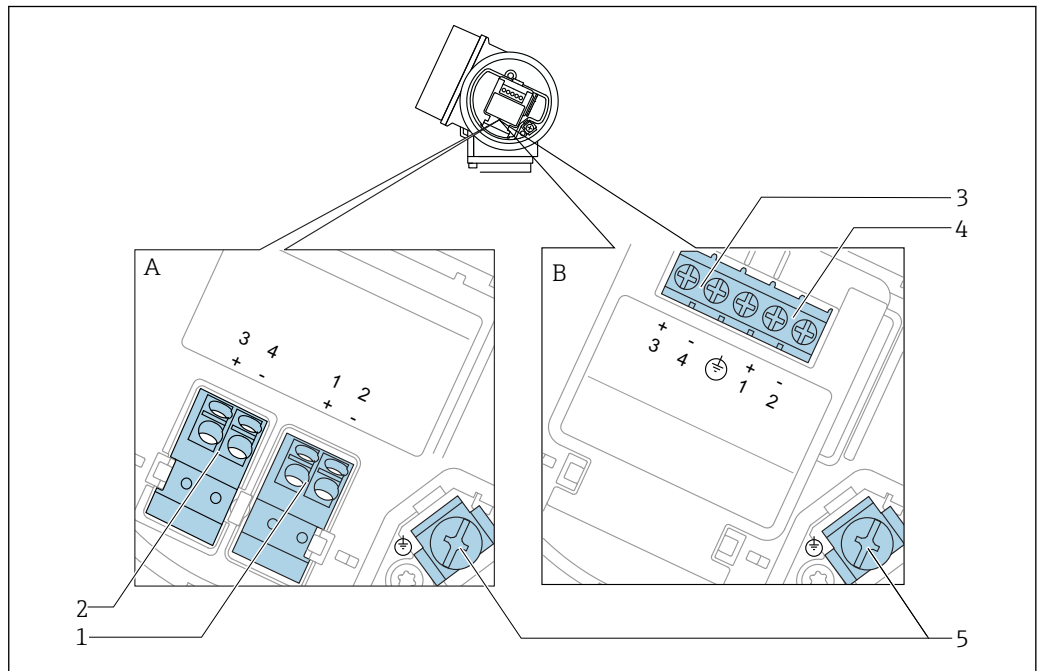

A0036500

14 Terminal assignment PROFIBUS PA / FOUNDATION Fieldbus

- A Without integrated overvoltage protection
- B With integrated overvoltage protection
- 1 Connection PROFIBUS PA / FOUNDATION Fieldbus: terminals 1 and 2, without integrated overvoltage protection
- 2 Connection switch output (Open Collector): terminals 3 and 4, without integrated overvoltage protection
- 3 Connection switch output (Open Collector): terminals 3 and 4, with integrated overvoltage protection
- 4 Connection PROFIBUS PA / FOUNDATION Fieldbus: terminals 1 and 2, with integrated overvoltage protection
- 5 Terminal for cable screen

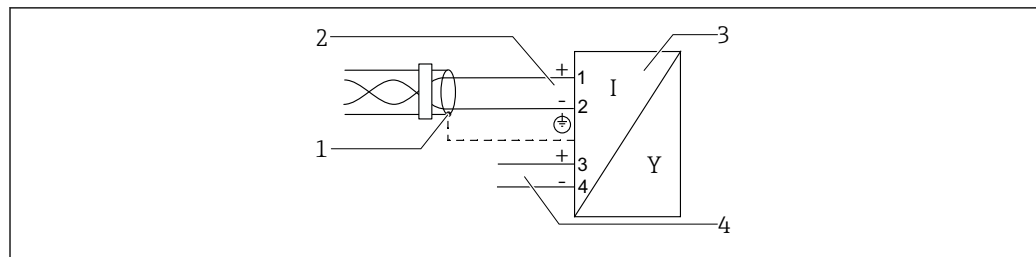
**Block diagram PROFIBUS PA / FOUNDATION Fieldbus**

A0036530

15 Block diagram PROFIBUS PA / FOUNDATION Fieldbus

- 1 Cable screen; observe cable specifications
- 2 Connection PROFIBUS PA / FOUNDATION Fieldbus
- 3 Measuring device
- 4 Switch output (open collector)

**Connection examples for the switch output**

**i** For HART devices, the switch output is available as an option.

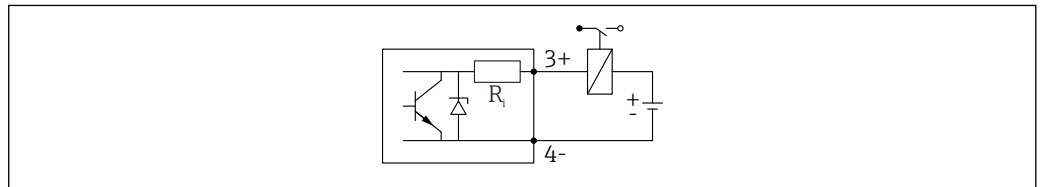

A0015909

**16** Connection of a relay

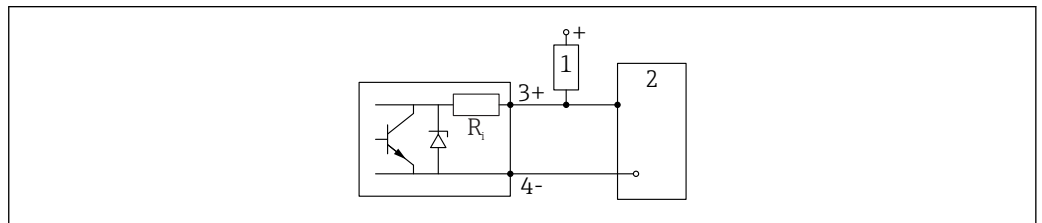

A0015910

**17** Connection to a digital input

- 1 Pull-up resistor
- 2 Digital input

**i** For optimum interference immunity we recommend to connect an external resistor (internal resistance of the relay or pull-up resistor) of  $< 1\ 000\ \Omega$ .

**Device plugs**

 In device versions with a device plug (M12 or 7/8"), it is not necessary to open the housing in order to connect the signal cable.

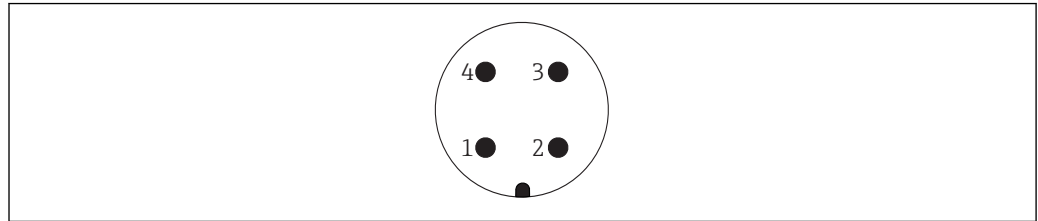

A0011175

 18 Pin assignment of M12 plug

- 1 Signal +
- 2 Not assigned
- 3 Signal -
- 4 Ground

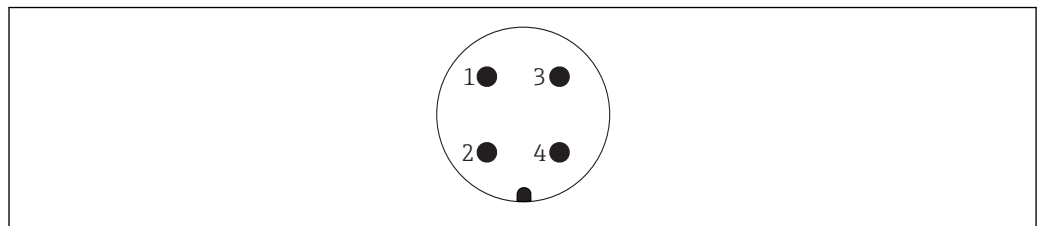

A0011176

 19 Pin assignment of 7/8" plug

- 1 Signal -
- 2 Signal +
- 3 Not assigned
- 4 Shielding

**Power supply**

An external power supply is required.

 Various supply units can be ordered from Endress+Hauser.

**2-wire, 4-20mA HART, passive**

2-wire; 4-20mA HART<sup>1)</sup>

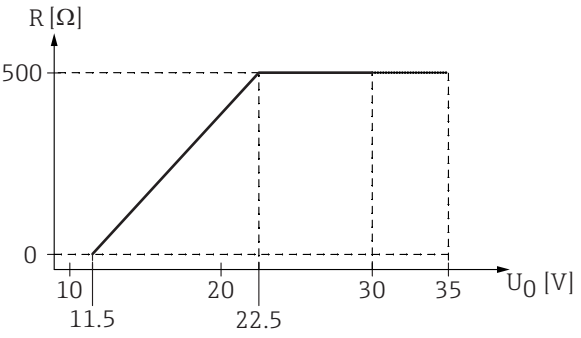
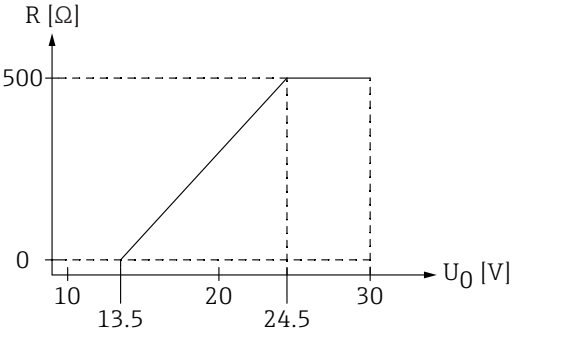
"Approval" <sup>2)</sup>	Terminal voltage U at the device	Maximum load R, depending on the supply voltage U <sub>0</sub> at the supply unit
<ul style="list-style-type: none"> <li>▪ Non-Ex</li> <li>▪ Ex nA</li> <li>▪ Ex ic</li> <li>▪ CSA GP</li> </ul>	11.5 to 35 V <sup>3) 4)</sup>	 <p style="text-align: right; font-size: small;">A0035511</p>
Ex ia / IS	11.5 to 30 V <sup>4)</sup>	
<ul style="list-style-type: none"> <li>▪ Ex d / XP</li> <li>▪ Ex ic[ia]</li> <li>▪ Ex tD / DIP</li> </ul>	13.5 to 30 V <sup>4) 5)</sup>	 <p style="text-align: right; font-size: small;">A0034969</p>

- 1) Feature 020 of the product structure: option A
- 2) Feature 010 of the product structure
- 3) For ambient temperatures  $T_a \leq -30\text{ °C}$  (-22 °F) a minimum voltage of 14 V is required for the startup of the device at the minimum error current (3,6 mA). For ambient temperatures  $T_a \geq 60\text{ °C}$  (140 °F) a minimum voltage of 12V is required for the sartup of the device at the minimum error current (3,6 mA). The startup current can be parametrized. If the device is operated with a fixed current  $I \geq 4,5\text{ mA}$  (HART multidrop mode), a voltage of  $U \geq 11,5\text{ V}$  is sufficient throughout the entire range of ambient temperatures.
- 4) If the Bluetooth modem is used, the minimum supply voltage increases by 2 V.
- 5) For ambient temperatures  $T_a \leq -20\text{ °C}$  (-4 °F) a minimum voltage of 16 V is required for the startup of the device at the minimum error current (3.6 mA).

2-wire; 4-20 mA HART, switch output<sup>1)</sup>

"Approval" <sup>2)</sup>	Terminal voltage U at the device	Maximum load R, depending on the supply voltage U <sub>0</sub> at the supply unit
<ul style="list-style-type: none"> <li>■ Non-Ex</li> <li>■ Ex nA</li> <li>■ Ex nA[ia]</li> <li>■ Ex ic</li> <li>■ Ex ic[ia]</li> <li>■ Ex d[ia] / XP</li> <li>■ Ex ta / DIP</li> <li>■ CSA GP</li> </ul>	13.5 to 35 V <sup>3) 4)</sup>	
<ul style="list-style-type: none"> <li>■ Ex ia / IS</li> <li>■ Ex ia + Ex d[ia] / IS + XP</li> </ul>	13.5 to 30 V <sup>3) 4)</sup>	

- 1) Feature 020 of the product structure: option B
- 2) Feature 010 of the product structure
- 3) For ambient temperatures  $T_a \leq -30\text{ °C}$  (-22 °F) a minimum voltage of 16 V is required for the startup of the device at the minimum error current (3.6 mA).
- 4) If the Bluetooth modem is used, the minimum supply voltage increases by 2 V.

2-wire; 4-20mA HART, 4-20mA<sup>1)</sup>

"Approval" <sup>2)</sup>	Terminal voltage U at the device	Maximum load R, depending on the supply voltage U <sub>0</sub> at the supply unit
any	<p><b>Channel 1:</b></p> <p>13.5 to 30 V<sup>3) 4) 5)</sup></p>	
	<p><b>Channel 2:</b></p> <p>12 to 30 V</p>	

- 1) Feature 020 of the product structure: option C
- 2) Feature 010 of the product structure
- 3) For ambient temperatures  $T_a \leq -30\text{ °C}$  (-22 °F) a minimum voltage of 16 V is required for the startup of the device at the minimum error current (3.6 mA).
- 4) For ambient temperatures  $T_a \leq -40\text{ °C}$  (-40 °F), the maximum terminal voltage must be restricted to  $U \leq 28\text{ V}$ .
- 5) If the Bluetooth modem is used, the minimum supply voltage increases by 2 V.

<b>Polarity reversal protection</b>	Yes
<b>Admissible residual ripple at f = 0 to 100 Hz</b>	$U_{SS} < 1\text{ V}$
<b>Admissible residual ripple at f = 100 to 10000 Hz</b>	$U_{SS} < 10\text{ mV}$

**4-wire, 4-20mA HART, active**

"Power supply; Output" <sup>1)</sup>	Terminal voltage	Maximum load R <sub>max</sub>
<b>K:</b> 4-wire 90-253VAC; 4-20mA HART	90 to 253 V <sub>AC</sub> (50 to 60 Hz), overvoltage category II	500 Ω
<b>L:</b> 4-wire 10,4-48VDC; 4-20mA HART	10.4 to 48 V <sub>DC</sub>	

1) Feature 020 of the product structure

**PROFIBUS PA, FOUNDATION Fieldbus**

"Power supply; Output" <sup>1)</sup>	"Approval" <sup>2)</sup>	Terminal voltage
<b>E:</b> 2-wire; FOUNDATION Fieldbus, switch output <b>G:</b> 2-wire; PROFIBUS PA, switch output	<ul style="list-style-type: none"> <li>▪ Non-Ex</li> <li>▪ Ex nA</li> <li>▪ Ex nA[ia]</li> <li>▪ Ex ic</li> <li>▪ Ex ic[ia]</li> <li>▪ Ex d[ia] / XP</li> <li>▪ Ex ta / DIP</li> <li>▪ CSA GP</li> </ul>	9 to 32 V <sup>3)</sup>
	<ul style="list-style-type: none"> <li>▪ Ex ia / IS</li> <li>▪ Ex ia + Ex d[ia] / IS + XP</li> </ul>	9 to 30 V <sup>3)</sup>

1) Feature 020 of the product structure

2) Feature 010 of the product structure

3) Input voltages up to 35 V will not spoil the device.

<b>Polarity sensitive</b>	No
<b>FISCO/FNICO compliant according to IEC 60079-27</b>	Yes

**Power consumption**

"Power supply; Output" <sup>1)</sup>	Power consumption
<b>A:</b> 2-wire; 4-20mA HART	< 0.9 W
<b>B:</b> 2-wire; 4-20mA HART, switch output	< 0.9 W
<b>C:</b> 2-wire; 4-20mA HART, 4-20mA	< 2 x 0.7 W
<b>K:</b> 4-wire 90-253VAC; 4-20mA HART	6 VA
<b>L:</b> 4-wire 10,4-48VDC; 4-20mA HART	1.3 W

1) Feature 020 of the product structure

**Current consumption**

**HART**

<b>Nominal current</b>	3.6 to 22 mA, the start-up current for multidrop mode can be parametrized (is set to 3.6 mA on delivery)
<b>Breakdown signal (NAMUR NE43)</b>	adjustable: 3.59 to 22.5 mA

**PROFIBUS PA**

<b>Nominal current</b>	14 mA
<b>Failure current FDE (Fault Disconnection Electronic)</b>	0 mA

**FOUNDATION Fieldbus**

Device basic current	15 mA
Failure current FDE (Fault Disconnection Electronic)	0 mA

**FISCO**

U <sub>i</sub>	17.5 V
I <sub>i</sub>	550 mA
P <sub>i</sub>	5.5 W
C <sub>i</sub>	5 nF
L <sub>i</sub>	10 µH

**Power supply failure**

- Configuration is retained in the HistoROM (EEPROM).
- Error messages (incl. value of operated hours counter) are stored.

**Potential equalization**

No special measures for potential equalization are required.



If the device is designed for hazardous areas, observe the information in the documentation "Safety Instructions" (XA).

**Terminals**

- **Without integrated overvoltage protection**  
Plug-in spring terminals for wire cross-sections 0.5 to 2.5 mm<sup>2</sup> (20 to 14 AWG)
- **With integrated overvoltage protection**  
Screw terminals for wire cross-sections 0.2 to 2.5 mm<sup>2</sup> (24 to 14 AWG)

**Cable entries**

**Connection of the power supply and signal cables**

To be selected in feature 050 "Electrical connection":

- Coupling M20, material depends on approval:
  - For non-Ex, ATEX, IECEX, NEPSI Ex ia/ic:  
Plastic M20x1.5 for cable Ø5 to 10 mm (0.2 to 0.39 in)
  - For Dust-Ex, FM IS, CSA IS, CSA GP, Ex ec:
  - For Ex db:  
No cable gland available
- Thread
  - ½" NPT
  - G ½"
  - M20 × 1.5
- M12 plug / 7/8" plug  
Only available for non-Ex, Ex ic, Ex ia

**Connection of remote display FHX50**

Feature 030 "Display, operation"	Cable entry for connection of FHX50
L: "Prepared for display FHX50 + M12 connection"	M12 socket
M: "Prepared for display FHX50 + M16 cable gland, custom connection"	M12 cable gland
N: "Prepared for display FHX50 + NPT1/2 thread, custom connection"	Thread NPT1/2

**Cable specification**

- **Devices without integrated overvoltage protection**  
Pluggable spring-force terminals for wire cross-sections 0.5 to 2.5 mm<sup>2</sup> (20 to 14 AWG)
- **Devices with integrated overvoltage protection**  
Screw terminals for wire cross-sections 0.2 to 2.5 mm<sup>2</sup> (24 to 14 AWG)
- For ambient temperature T<sub>U</sub> ≥ 60 °C (140 °F): use cable for temperature T<sub>U</sub> + 20 K.

**HART**

- A normal device cable suffices if only the analog signal is used.
- A shielded cable is recommended if using the HART protocol. Observe grounding concept of the plant.
- For 4-wire devices: Standard device cable is sufficient for the power line.

**PROFIBUS**

Use a twisted, screened two-wire cable, preferably cable type A.

-  For further information on the cable specifications, see Operating Instructions BA00034S "PROFIBUS DP/PA: Guidelines for planning and commissioning", PNO Guideline 2.092 "PROFIBUS PA User and Installation Guideline" and IEC 61158-2 (MBP).

**FOUNDATION Fieldbus**

Endress+Hauser recommends using twisted, shielded two-wire cables.

-  For further information on the cable specifications, see Operating Instructions BA00013S "FOUNDATION Fieldbus Overview", FOUNDATION Fieldbus Guideline and IEC 61158-2 (MBP).

**Overvoltage protection**

If the measuring device is used for level measurement in flammable liquids which requires the use of overvoltage protection according to DIN EN 60079-14, standard for test procedures 60060-1 (10 kA, pulse 8/20 µs), an overvoltage protection module has to be installed.

**Integrated overvoltage protection module**

An integrated overvoltage protection module is available for 2-wire HART as well as PROFIBUS PA and FOUNDATION Fieldbus devices.

Product structure: Feature 610 "Accessory mounted", option NA "Overvoltage protection".

Technical data	
Resistance per channel	2 × 0.5 Ω max.
Threshold DC voltage	400 to 700 V
Threshold impulse voltage	< 800 V
Capacitance at 1 MHz	< 1.5 pF
Nominal arrest impulse voltage (8/20 µs)	10 kA

**External overvoltage protection module**

HAW562 or HAW569 from Endress+Hauser are suited as external overvoltage protection.

-  For detailed information please refer to the following documents:
- HAW562: TI01012K
  - HAW569: TI01013K

## Performance characteristics

### Reference operating conditions

- Temperature = +24 °C (+75 °F) ±5 °C (±9 °F)
- Pressure = 960 mbar abs. (14 psia) ±100 mbar (±1.45 psi)
- Humidity = 60 % ±15 %
- Reflection factor ≥ 0.8 (metal plate for rod probe with min. 1 m (40 in) diameter)
- Flange for rod probe ≥ 300 mm (12 in) diameter
- Distance to obstacles ≥ 1 m (40 in)

### Reference accuracy

Typical data under reference operating conditions: DIN EN IEC 61298-2 / DIN EN IEC 60770-1; percentage values in relation to the span.

Output:	digital	analog <sup>1)</sup>
Accuracy (sum of non-linearity, non-repeatability and hysteresis) <sup>2)</sup>	±2 mm (±0.08 in)	±0.02 %
Non-repeatability <sup>3)</sup>	≤1 mm (0.04 in)	

- 1) Add error of the analog value to the digital value.
- 2) If the reference conditions are not met, the offset/zero point resulting from the installation conditions can be up to ±16 mm (±0.63 in). This additional offset/zero point can be compensated for by entering a correction ("Level correction" parameter) during commissioning.
- 3) The non-repeatability is already considered in the accuracy.

Differing from this, the following measured error applies in the area of the lower probe end:

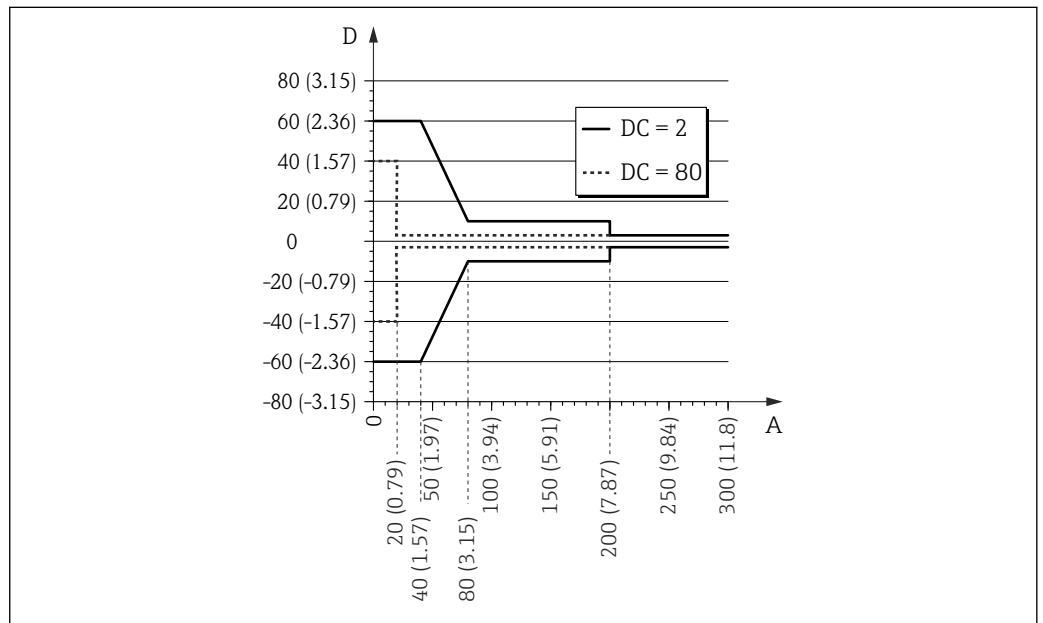

20 Measured error at the probe end for rod and coax probes

A Distance from the probe end [mm(in)]

D Measured error: Sum of non-linearity, non-repeatability and hysteresis

The following measured error applies in the area of the upper probe end:

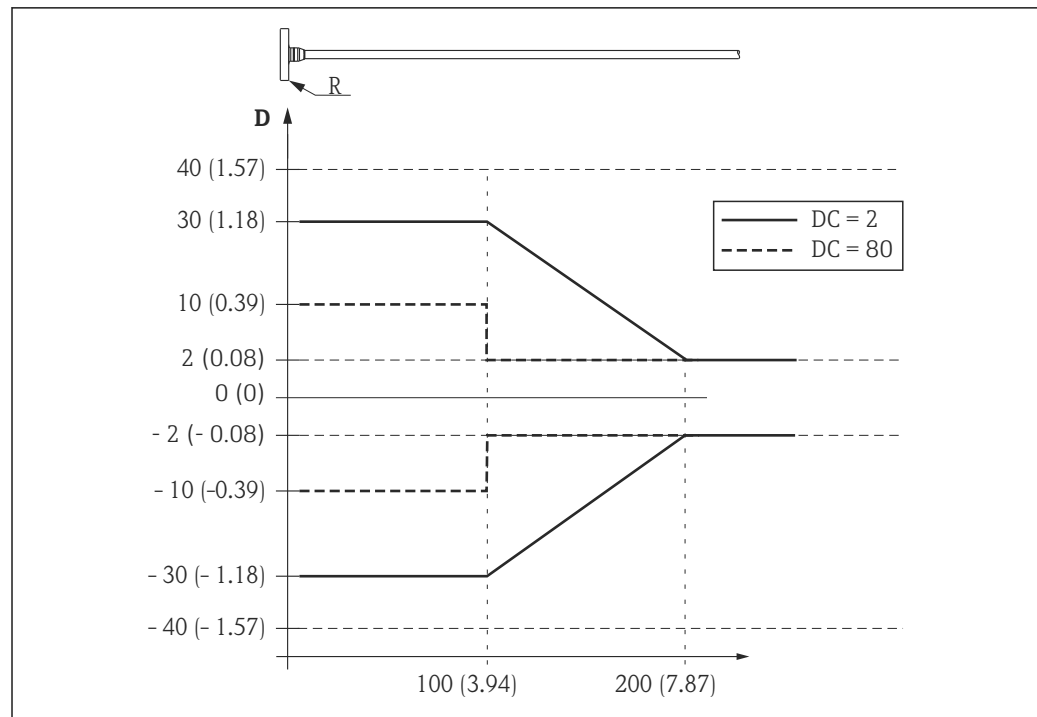

21 Measured error at the upper probe end; engineering unit: mm (in)

D Sum of non-linearity, non-repeatability and hysteresis  
 R Reference point of measurement  
 DC Dielectric constant

**Resolution**

- Digital: 1 mm
- Analog: 1 µA

**Response time**

The response time can be configured. The following step response times (in accordance with DIN EN IEC 61298-2 / DIN EN IEC 60770-1)<sup>1)</sup> are when damping is switched off:

Level measurement		
Probe length	Sampling rate	Response time
< 10 m (33 ft)	3.6 measurements per second	< 0.8 s
< 40 m (131 ft)	≥ 2.7 measurements per second	< 1 s

**Influence of ambient temperature**

The measurements are performed according to DIN EN IEC 61298-3 / DIN EN IEC 60770-1

- Digital (HART, PROFIBUS PA, FOUNDATION Fieldbus): average  $T_K = 0.6 \text{ mm}/10 \text{ K}$
- Analog (current output):
  - Zero point (4 mA): average  $T_K = 0.02 \text{ } \%/10 \text{ K}$
  - Span (20 mA): average  $T_K = 0.05 \text{ } \%/10 \text{ K}$

1) According to DIN EN IEC 61298-2 / DIN EN IEC 60770-1, the step response time is the time that elapses after an abrupt change in the input signal until the change in the output signal has adopted 90% of the steady-state value for the first time.

## Installation

### Installation conditions

### Suitable mounting position

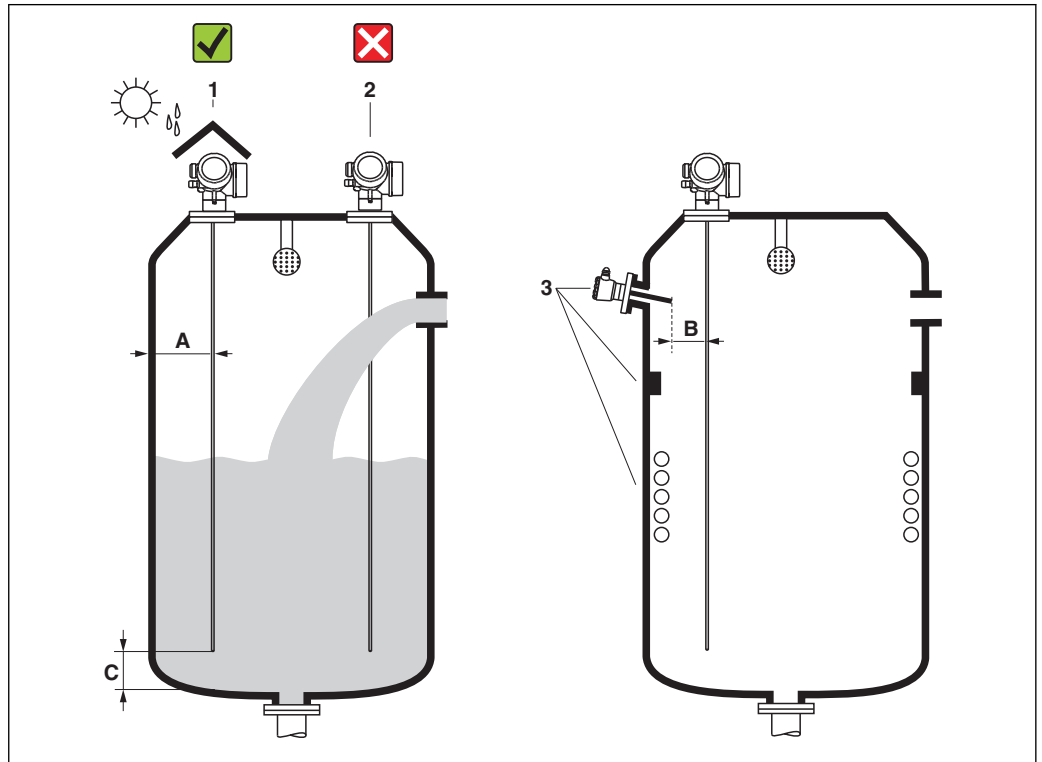

22 Installation conditions for Levelflex

A0014130

### Spacing requirements when mounting

- Distance (A) between the vessel wall and rod probes:
  - For smooth metallic walls: > 50 mm (2 in)
  - For plastic walls: > 300 mm (12 in) to metallic parts outside the vessel
- Distance (B) between rod probes and internal fittings (4): > 300 mm (12 in)
- When using more than one Levelflex:
  - Minimum distance between the sensor axes: 100 mm (3.94 in)
- Distance (C) from the end of the probe to the bottom of the vessel: > 10 mm (0.4 in)

*Additional conditions*

- When mounting outdoors, a weather protection cover (1) can be used to protect the device against extreme weather conditions.
- Do not mount the probe in the filling curtain (2).
-  When the housing is mounted in a recess (e.g. in a concrete ceiling), observe a minimum distance of 100 mm (4 in) between the cover of the connection compartment/electronics compartment and the wall. Otherwise the connection compartment/electronics compartment will not be accessible after installation.

### Mounting under confined conditions

#### Mounting with remote probe

The device version with a remote probe is suitable for applications with restricted mounting space (product structure: probe design). In this case, the electronics housing is mounted at a separate position from the probe.

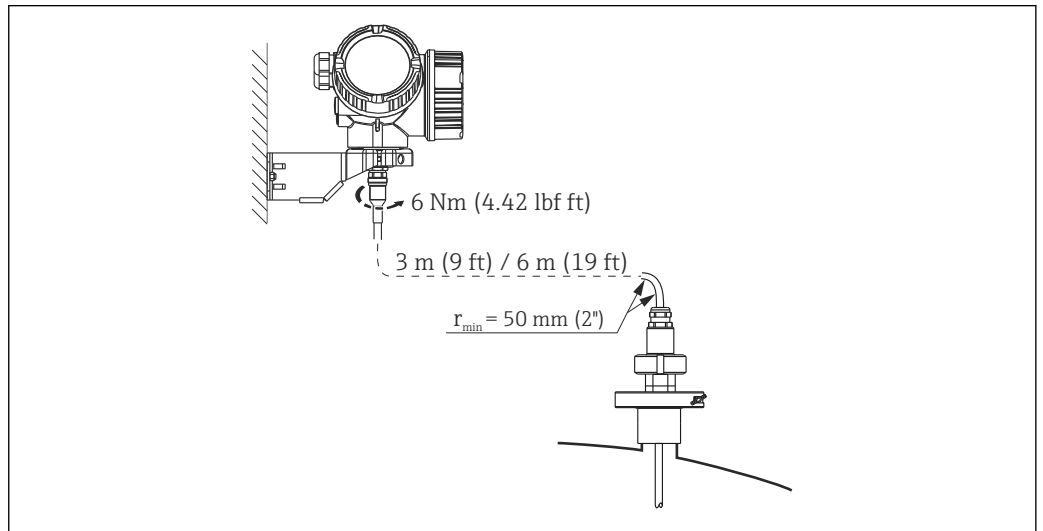

A0015103

- The connecting cable is connected to the probe upon delivery.
  - Length: 3 m (9 ft) or 6 m (18 ft)
  - Minimum bending radius: 50 mm (2 inch)
- The mounting bracket for the electronics housing is included in the delivery with this version.
 

Mounting options:

  - Wall mounting
  - Mounting on DN32 to DN50 (1-1/4 to 2 inch) post or pipe

**i** The probe with the connection cable and the electronics are mutually compatible and bear a common serial number. Only components with the same serial number may be connected to one another.

### Separable probes

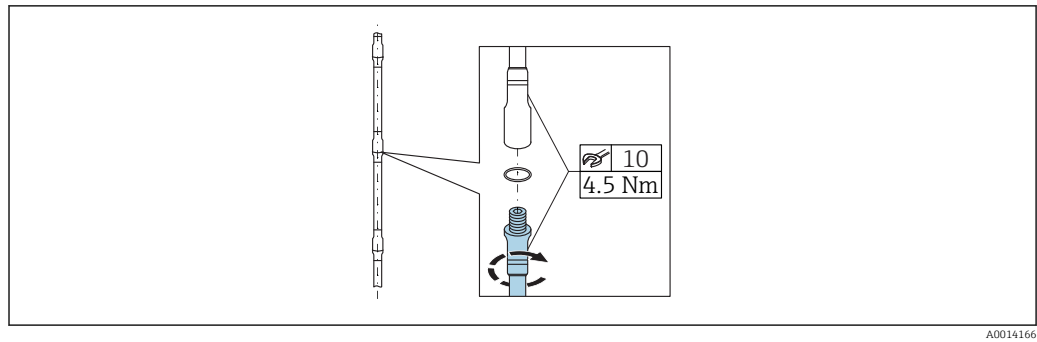

The use of separable rod probes ( $\varnothing$  8 mm) is advisable in confined mounting conditions (limited distance to the ceiling).

- Max. probe length 6 m (19.68 ft)
- Max. lateral loading capacity 10 Nm
- Probes can be separated several times, with the individual parts having the following lengths:
  - 500 mm (20 in)
  - 1 000 mm (40 in)
- The connection points are sealed gap-free by an O-ring.

**i** To avoid damage to the surface of the probe: use fitting pliers with a plastic surface to mount the probe rod.

**Notes on the mechanical load of the probe**

*Lateral loading capacity (flexural strength) of rod probes*

FMP53

**Rod 8mm (0.31") 316L**

10 Nm

**Rod 8mm (0.31") 316L separable**

10 Nm

*Lateral load (bending moment) from flow conditions*

The formula for calculating the bending moment M acting on the probe:

$$M = c_w \times \rho / 2 \times v^2 \times d \times L \times (L_N - 0.5 \times L)$$

With:

$c_w$ : coefficient of friction

$\rho$  [kg/m<sup>3</sup>]: density of the medium

$v$  [m/s]: flow velocity of the medium, perpendicular to the probe rod

$d$  [m]: diameter of the probe rod

$L$  [m]: level

$L_N$  [m]: probe length

**Sample calculation**

Coefficient of friction  $c_w$  0.9 (assuming turbulent flow - high Reynolds number)

Density  $\rho$  [kg/m<sup>3</sup>] 1000 (e.g. water)

Probe diameter  $d$  [m] 0.008

$L = L_N$  (unfavorable conditions)

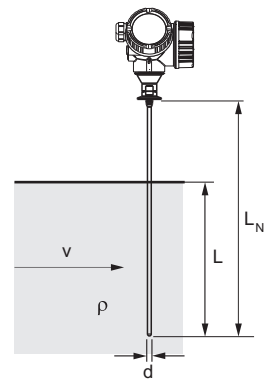

A0014175

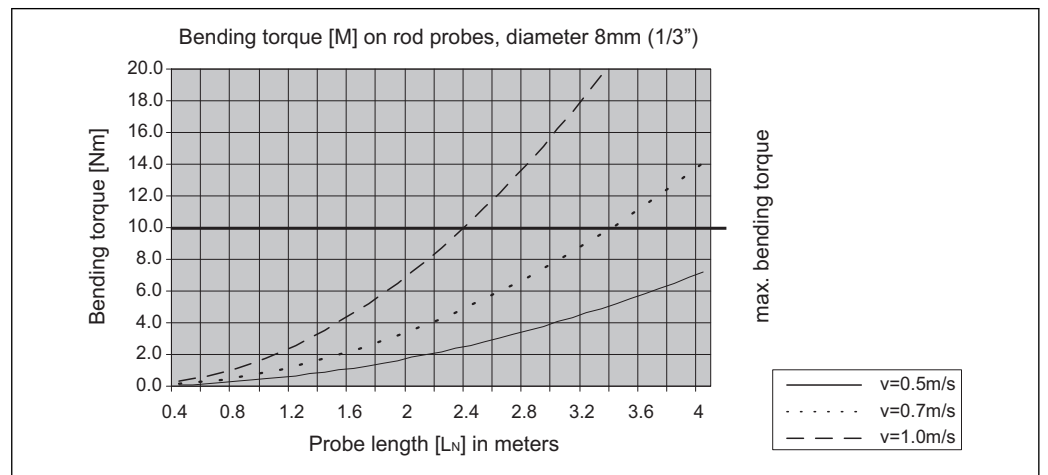

A0014182-EN

### Special installation situations

#### *Tanks with spray ball for probe cleaning*

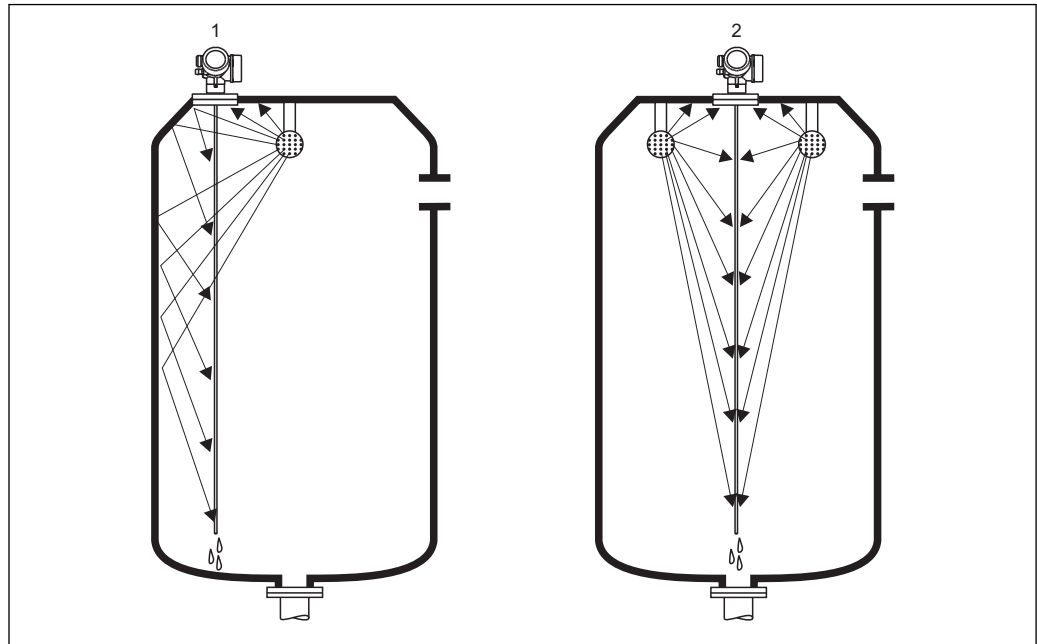

A0014131

#### *Mounting close to vessel wall*

Mounting the probe close to the vessel wall improves the cleaning effect when a spray ball is used. The cleaning jet is directed onto the probe via the vessel wall. As a result, the probe is also cleaned in places the spray ball jet would normally not reach. You only require one spray ball for this probe arrangement.

#### *Mounting in the center of the vessel*

If the probe is mounted in the center of the vessel, the use of a second spray ball may be necessary. These balls should then be mounted to the left and right of the probe.

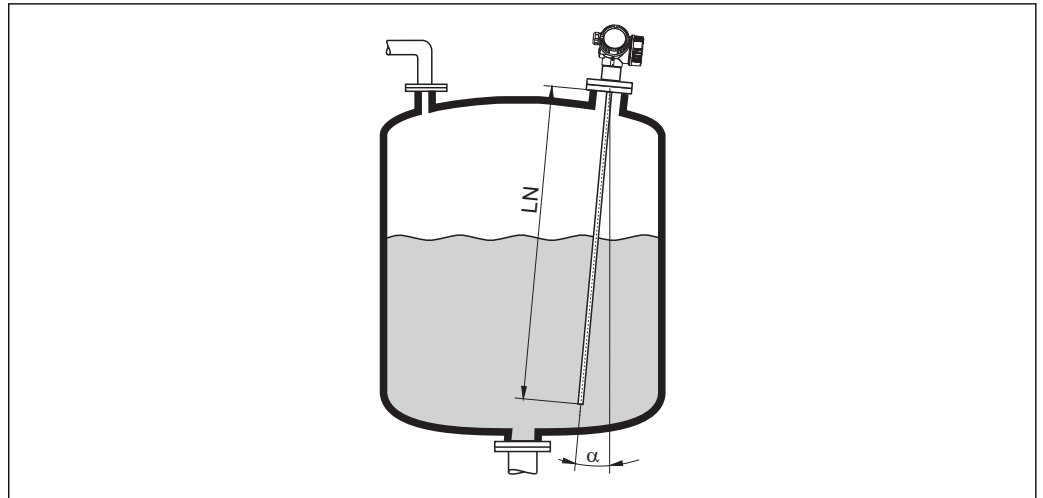
*Mounting at an angle*

A0014145

- For mechanical reasons, the probe should be installed as vertically as possible.
- If the probe is installed at an angle, the length of the probe must be reduced depending on the angle of installation.
  - $\alpha 5^\circ$ :  $LN_{\max.}$  4 m (13.1 ft)
  - $\alpha 10^\circ$ :  $LN_{\max.}$  2 m (6.6 ft)
  - $\alpha 30^\circ$ :  $LN_{\max.}$  1 m (3.3 ft)

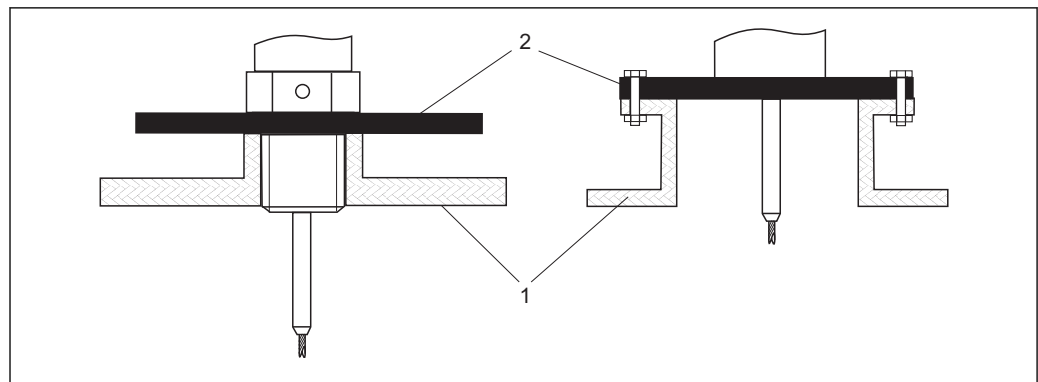
*Non-metal vessels*

- 1 *Non-metal vessel*  
2 *Metal sheet or metal flange*

To ensure good measurement results when mounting on non-metal vessels, at the process connection mount a metal sheet with a diameter of at least 200 mm (8 in) at a right angle to the probe.

*Plastic and glass vessels: Mounting the probe on the outside wall*

In the case of plastic and glass vessels, the probe can also be mounted on the outside wall under certain conditions.

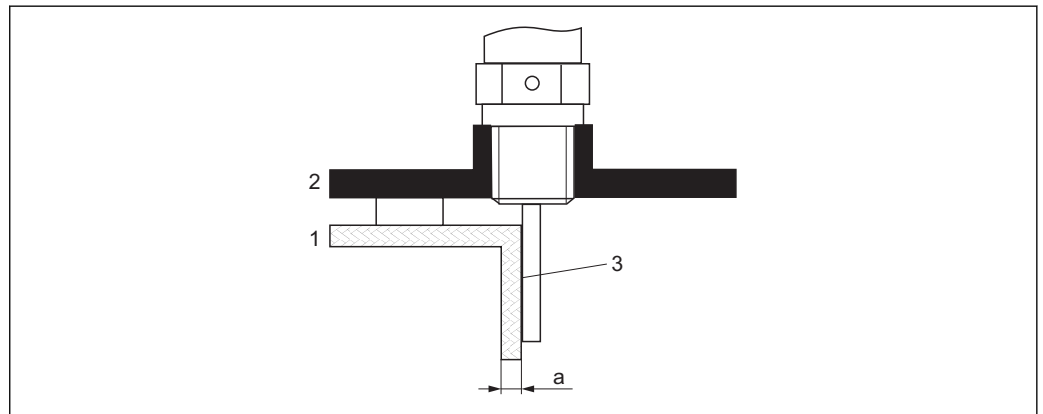

A0014150

- 1 Plastic or glass vessel
- 2 Metal plate with screw-in sleeve
- 3 No space between vessel wall and probe!

**Requirements**

- Dielectric constant of the medium:  $\epsilon_r > 7$ .
- Non-conductive vessel wall.
- Maximum wall thickness (a):
  - Plastic: < 15 mm (0.6 in)
  - Glass: < 10 mm (0.4 in)
- No metal reinforcements on the vessel.

**Note the following when mounting the device:**

- Mount the probe directly on the vessel wall without any space between the wall and probe.
- To prevent any influence on the measurement, fit a plastic half pipe with a diameter of at least 200 mm (8 in), or a similar protective unit, on the probe.
- For vessel diameters less than 300 mm (12 in):  
On the opposite side of the vessel, fit a grounding plate that is conductively connected to the process connection and covers around half of the vessel's circumference.
- For vessel diameters of 300 mm (12 in) and higher:  
At the process connection, fit a metal plate with a diameter of at least 200 mm (8 in) at a right angle to the probe (see above).

*Vessel with thermal insulation*

**i** If process temperatures are high, the device must be included in normal vessel insulation (1) in order to prevent the electronics heating up as a result of thermal radiation or convection. The insulation may not go beyond the points labeled "MAX" in the drawings.

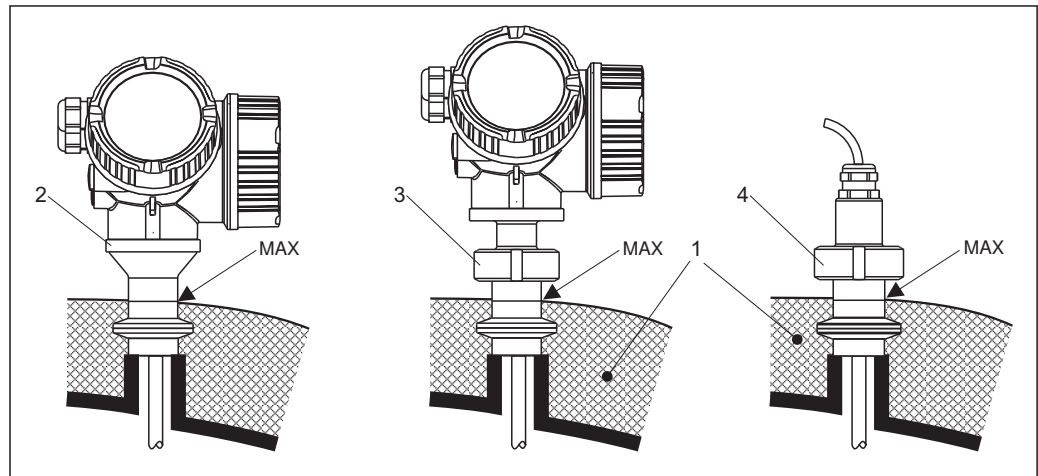

A0015809

**23** *Hygienic process connections*

- 1 Vessel insulation
- 2 Compact device
- 3 Compact device, detachable
- 4 Sensor, remote

## Operating conditions: Environment

<b>Ambient temperature</b>	<b>Measuring device</b>	-20 to +80 °C (-4 to +176 °F)
	<b>Local display</b>	-20 to +70 °C (-4 to +158 °F), the readability of the display may be impaired at temperatures outside the temperature range.
	<b>Connecting cable (for "Sensor, remote" probe design)</b>	Max. 150 °C (302 °F)
	<b>Remote display FHX50</b>	-40 to 80 °C (-40 to 176 °F)

For outdoor operation in strong sunlight:

- Mount the device in the shade.
- Avoid direct sunlight, particularly in warm climatic regions.
- Use a weather protection cover (see accessories).

**Ambient temperature limits** The following diagrams only consider functional aspects. Additional restrictions may apply for certified device versions. See the separate Safety Instructions for more information.

In the event of temperature ( $T_p$ ) at the process connection, the permitted ambient temperature ( $T_a$ ) is reduced as indicated in the following diagram (temperature derating):

Temperature derating for FMP53

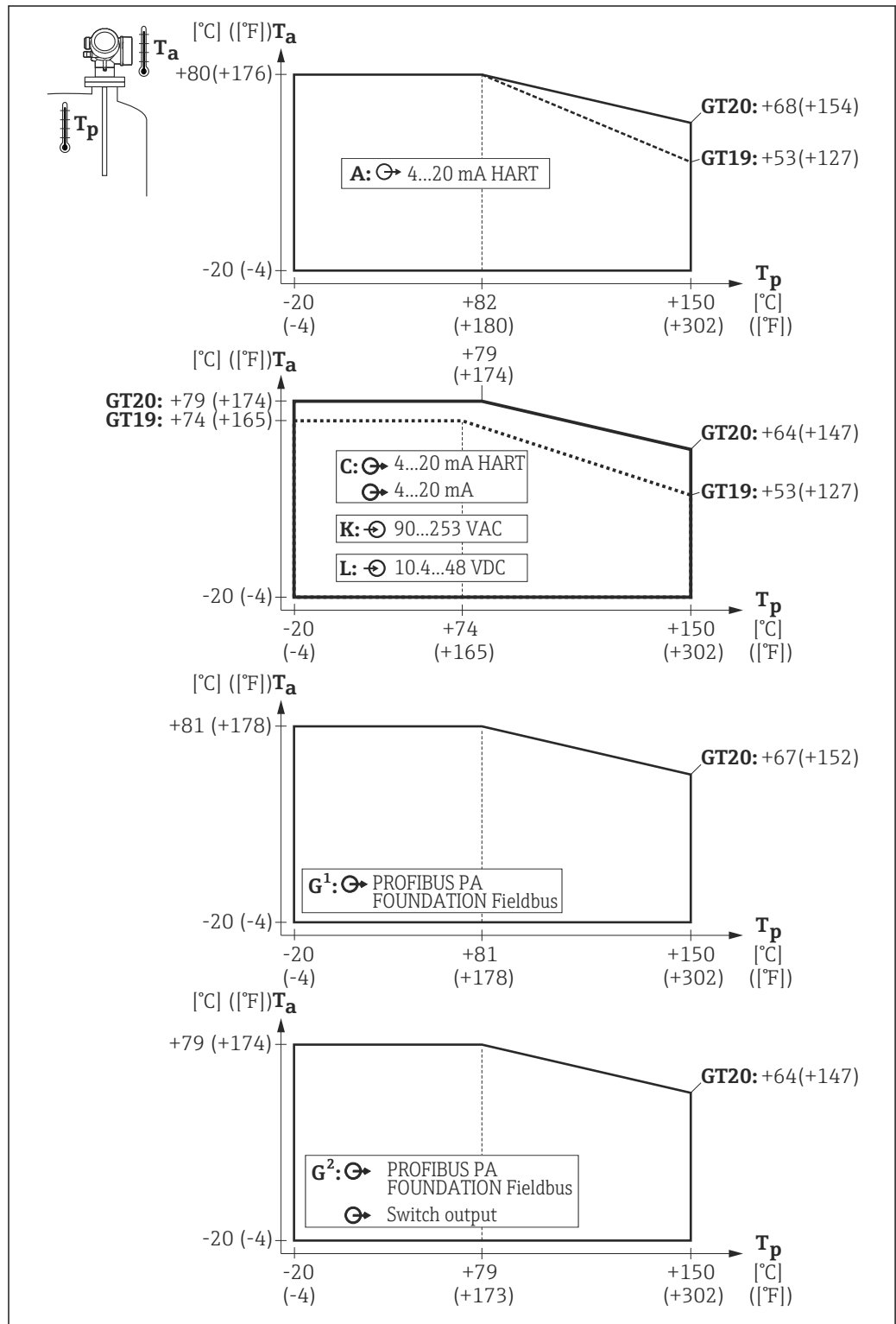



A0013635

GT19 = Plastic housing  
GT20 = Aluminum housing

A = 1 current output  
C = 2 current outputs  
G<sup>1</sup>, G<sup>2</sup> = PROFIBUS PA<sup>1)</sup>  
K, L = 4-wire

$T_a$  = Ambient temperature  
 $T_p$  = Temperature at the process connection

1) In the case of PROFIBUS PA and FOUNDATION Fieldbus, the temperature derating depends on whether the switch output (terminals 3 and 4) is used (G<sup>2</sup>) or not (G<sup>1</sup>).

<b>Storage temperature</b>	<ul style="list-style-type: none"> <li>■ Permitted storage temperature: -40 to +80 °C (-40 to +176 °F)</li> <li>■ Use original packaging.</li> </ul>
<b>Climate class</b>	DIN EN 60068-2-38 (test Z/AD)
<b>Altitude according to IEC61010-1 Ed.3</b>	<ul style="list-style-type: none"> <li>■ Generally up to 2 000 m (6 600 ft) above MSL.</li> <li>■ Above 2 000 m (6 600 ft) if the following conditions are met: <ul style="list-style-type: none"> <li>■ Ordering feature 020 "Power supply; Output" = A, B, C, E or G (2-wire versions)</li> <li>■ Supply voltage <math>U &lt; 35\text{ V}</math></li> <li>■ Supply voltage of overvoltage category 1</li> </ul> </li> </ul>
<b>Degree of protection</b>	<ul style="list-style-type: none"> <li>■ When housing is closed, tested according to: <ul style="list-style-type: none"> <li>■ IP68, NEMA6P (24 h at 1.83 m under water) (also applies for the "Remote sensor" version)</li> <li>■ For plastic housing with see-through lid (display): IP68 (24 h at 1.00 m under water) This restriction applies if the following options have been selected simultaneously in the product structure: 030 ("Display/operation") = C ("SD02") or E ("SD03"); 040 ("Housing") = A ("GT19").</li> </ul> </li> <li>■ IP66, NEMA4X</li> <li>■ With housing open: IP20, NEMA1</li> <li>■ Display module: IP22, NEMA2</li> </ul> <p> Degree of protection IP68 NEMA6P only applies for M12 PROFIBUS PA plugs if the PROFIBUS cable is plugged in and is also rated IP68 NEMA6P.</p>
<b>Vibration resistance</b>	DIN EN 60068-2-64 / IEC 60068-2-64: 20 to 2 000 Hz, 1 (m/s <sup>2</sup> )/Hz
<b>Cleaning the probe</b>	<p>Dirt or buildup may form on the probe depending on the application. A thin, even layer has little impact on the measurement. Thick layers can dampen the signal and then reduce the measuring range. Very uneven deposit formation, e.g. caking due to crystallization, can result in incorrect measurements. In such cases, we recommend the use of a non-contact measuring principle, or a regular inspection of the probe for contamination.</p>
<b>Electromagnetic compatibility (EMC)</b>	<p>Electromagnetic compatibility in accordance with all of the relevant requirements outlined in the EN 61326 series and NAMUR Recommendation EMC (NE 21). For details, refer to the Declaration of Conformity.</p> <p> Download at <a href="http://www.endress.com">www.endress.com</a>.</p> <p>Use a shielded cable for signal transmission.</p> <p>Maximum measured error during EMC testing: &lt; 0.5 % of the span.</p> <p>When the probes are installed in metal and concrete vessels and when a coax probe is used:</p> <ul style="list-style-type: none"> <li>■ Interference emission according to EN 61326 - x series, Class B equipment.</li> <li>■ Interference immunity according to EN 61326 - x series, requirements for industry and NAMUR Recommendation NE 21 (EMC)</li> </ul> <p>When probes are installed without a shielding/metal wall, e.g. installation in plastic or wooden silos, the effect of strong electromagnetic fields can influence the measured value.</p> <ul style="list-style-type: none"> <li>■ Interference emission according to EN 61326 - x series, Class A equipment.</li> <li>■ Interference immunity: the effect of strong electromagnetic fields can influence the measured value.</li> </ul>

## Process

### Process temperature range

The maximum temperature permitted at the process connection is determined by the O-ring version ordered:

Device	O-ring material	Process temperature	Approval
FMP53	EPDM (Freudenberg 70 EPDM 291)	-20 to +130 °C (-4 to +266 °F)	FDA 3A <sup>1)</sup> EHEDG USP Cl. VI <sup>2)</sup>
	FFKM (Kalrez 6221)	-20 to +150 °C (-4 to +302 °F)	FDA 3A <sup>3)</sup> EHEDG USP Cl. VI <sup>2)</sup>
	FKM (PPE V70SW)	-10 to +150 °C (+10 to +302 °F)	

- 1) Tested according to 3A Sanitary Standard 18-03, Class II
- 2) Tested according to USP <88> Class VI - 121°C
- 3) Tested according to 3A Sanitary Standard 18-03, Class I

### Process pressure range

Device	Process pressure
FMP53	-1 to 16 bar (-14.5 to 232 psi)



The range indicated can be reduced by the choice of process connection. The nominal pressure (PN) indicated on the nameplate refers to a reference temperature of 20 °C. Observe pressure-temperature dependency.

### Dielectric constant (DC)

Rod probe: DC ( $\epsilon_r$ )  $\geq$  1.6

## Mechanical construction

### Dimensions

#### Dimensions of the electronics housing

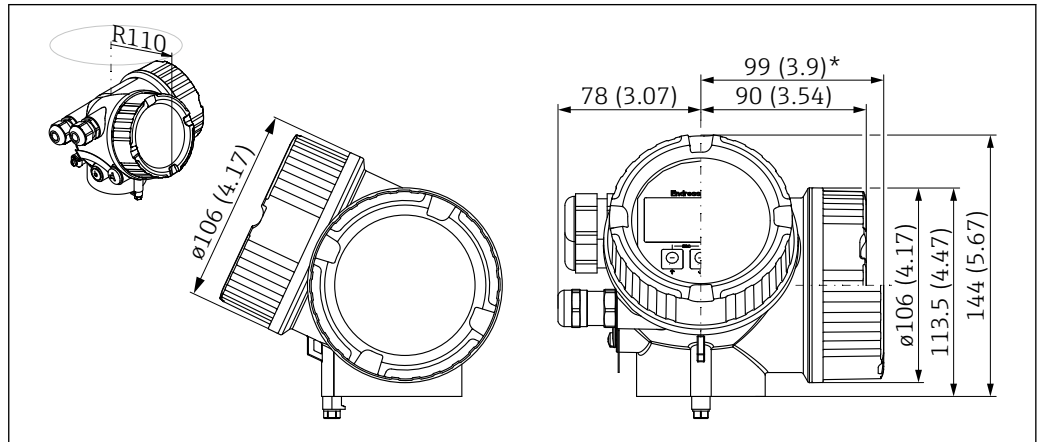

A0011346

▣ 24 GT19 housing (plastic PBT). Unit of measurement mm (in)

\*For devices with integrated overvoltage protection.

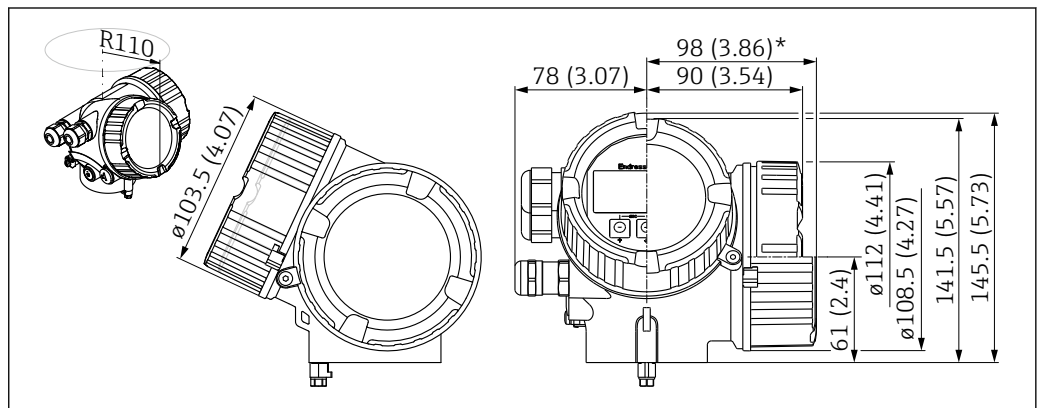

A0020751

▣ 25 Housing GT20 (aluminum coated). Unit of measurement mm (in)

\*For devices with integrated overvoltage protection.

Mounting bracket dimensions

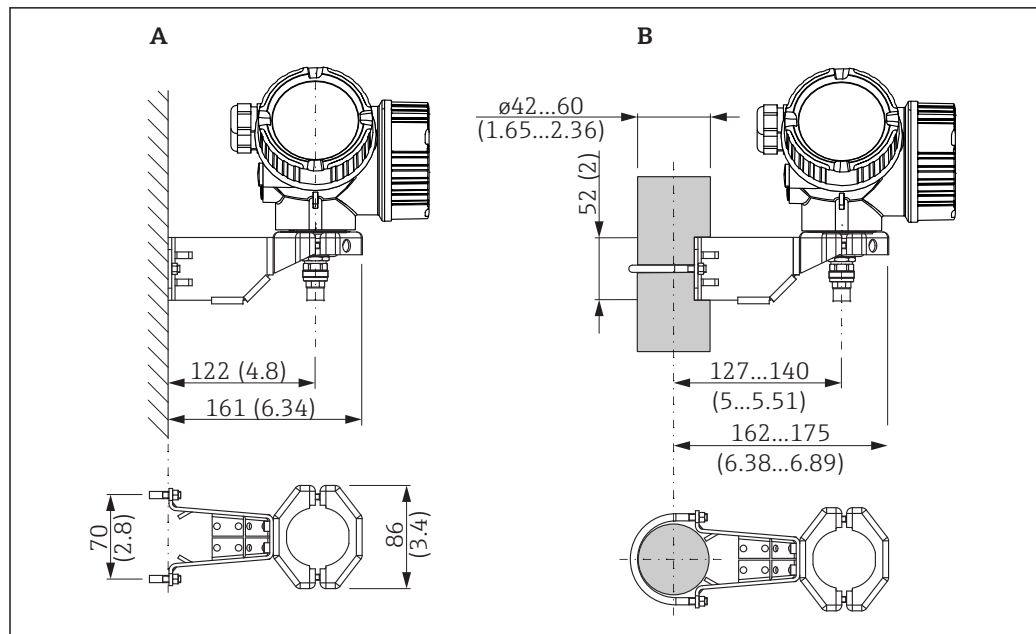

A0014793

26 Mounting bracket for electronics housing. Unit of measurement mm (in)

A Wall mounting

B Post mounting

**i** With "remote sensor" device versions (see feature 060 in the product structure), the mounting bracket is included in the scope of delivery. However, it can also be ordered separately as an accessory (order number: 71102216).

**FMP53: Dimensions of process connection**

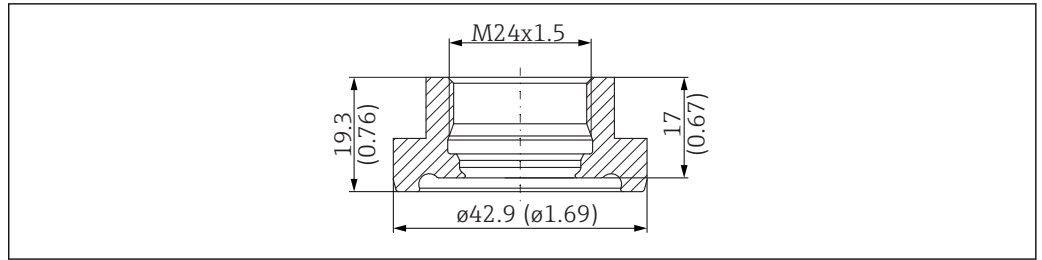

27 DIN11864-1 A DN25 pipe DIN11866-A, 316L. Unit of measurement mm (in)

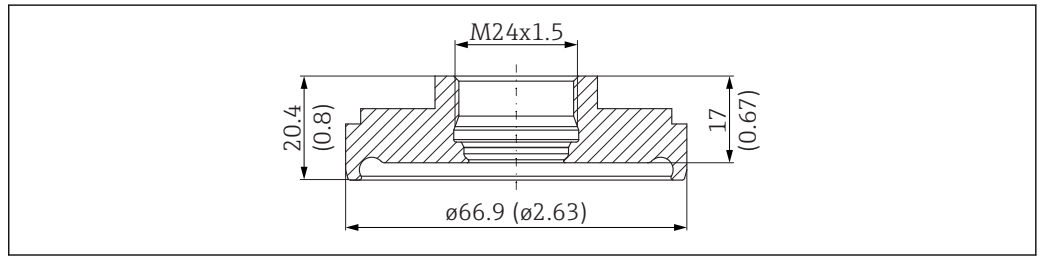

28 DIN11864-1 A DN50 pipe DIN11866-A, 316L. Unit of measurement mm (in)

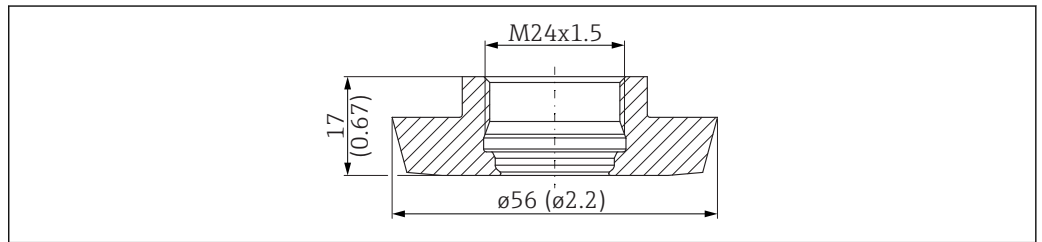

29 DIN11851 DN40 PN40 slotted-nut, 316L. Unit of measurement mm (in)

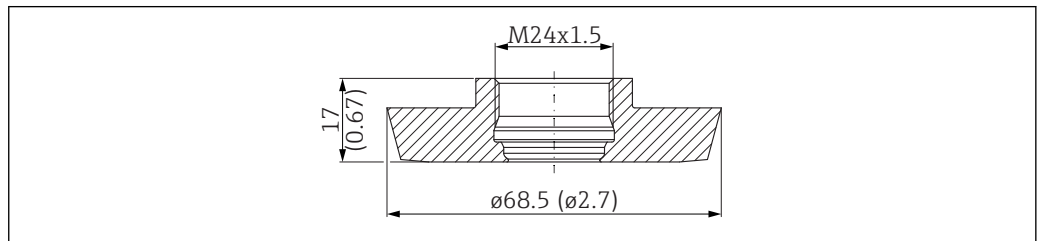

30 DIN11851 DN40 PN25 slotted-nut, 316L. Unit of measurement mm (in)

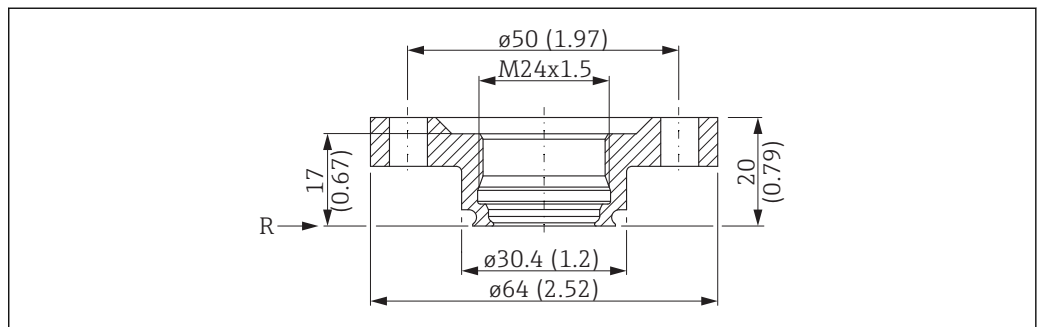

31 NEUMO BioControl D25 PN16, 316L. Unit of measurement mm (in)

R Reference point of measurement

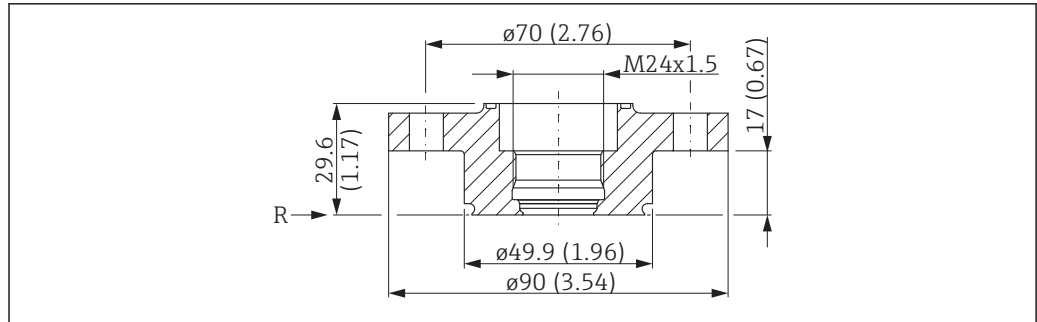

A0012768

32 NEUMO BioControl D50 PN16, 316L. Unit of measurement mm (in)

R Reference point of measurement

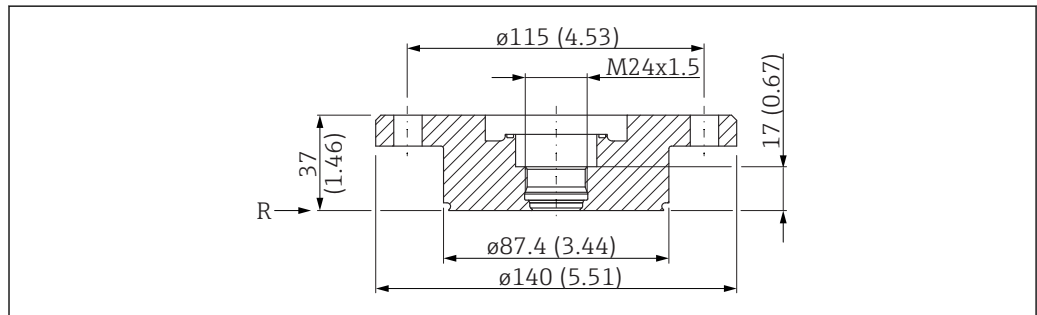

A0012769

33 NEUMO BioControl D80 PN16, 316L. Unit of measurement mm (in)

R Reference point of measurement

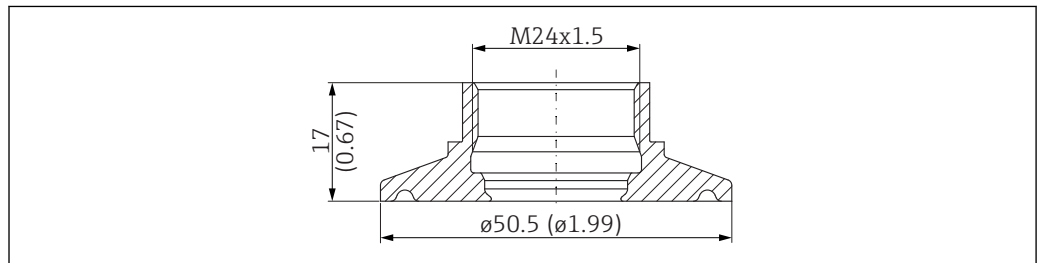

A0012772

34 Tri-Clamp ISO2852 DN25-38 (1 to 1-1/2"), 316L. Unit of measurement mm (in)

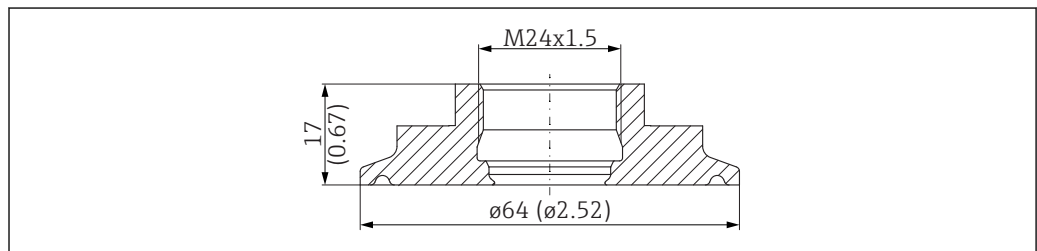

A0012770

35 Tri-Clamp ISO2852 DN40-51 (2"), 316L. Unit of measurement mm (in)

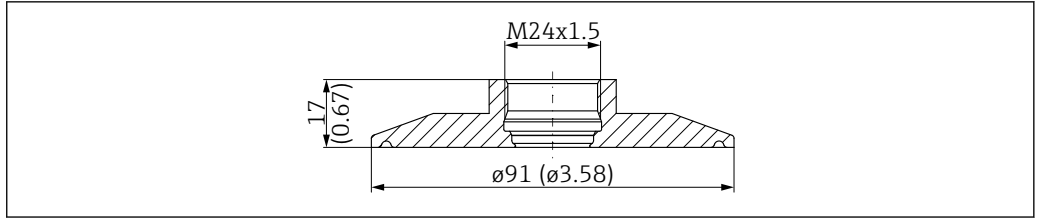

A0035143

36 Tri-Clamp ISO2852 DN70-76.1 (3"), 316L. Unit of measurement mm (in)

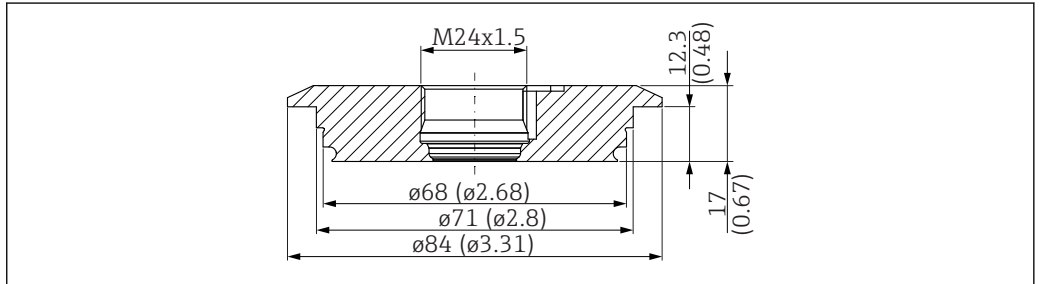

A0012773

37 Varivent N tube DN40-162 PN16, 316L. Unit of measurement mm (in)

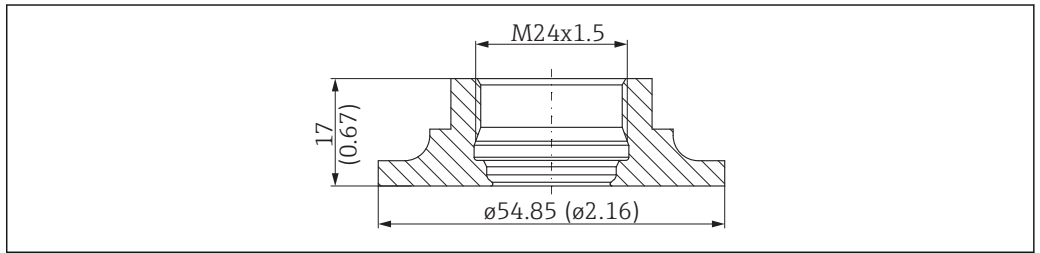

A0012775

38 SMS 1-1/2" PN25, 316L. Unit of measurement mm (in)

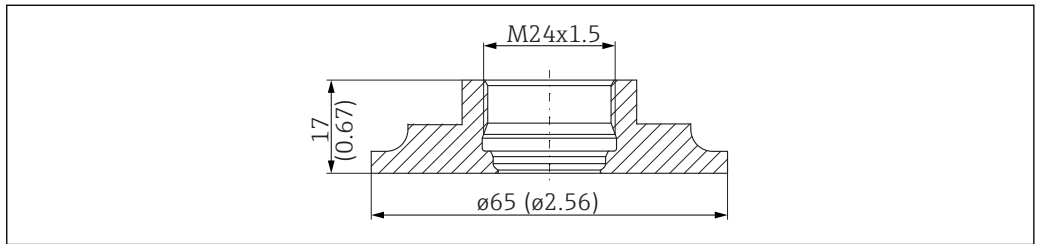

A0012774

39 SMS 2" PN25, 316L. Unit of measurement mm (in)

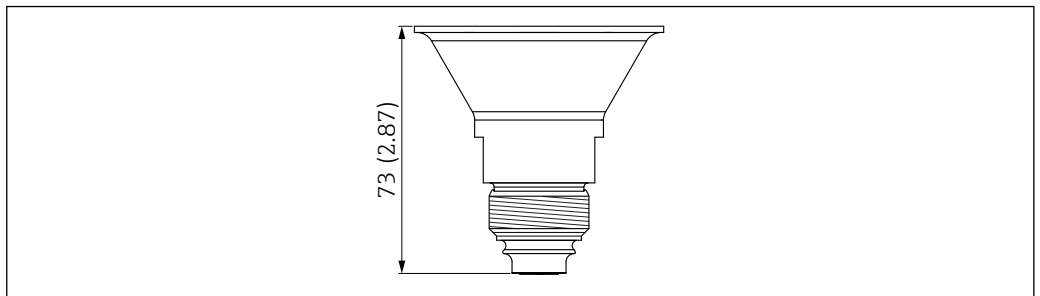

A0014608

40 Thread M24, 316L. Unit of measurement mm (in)

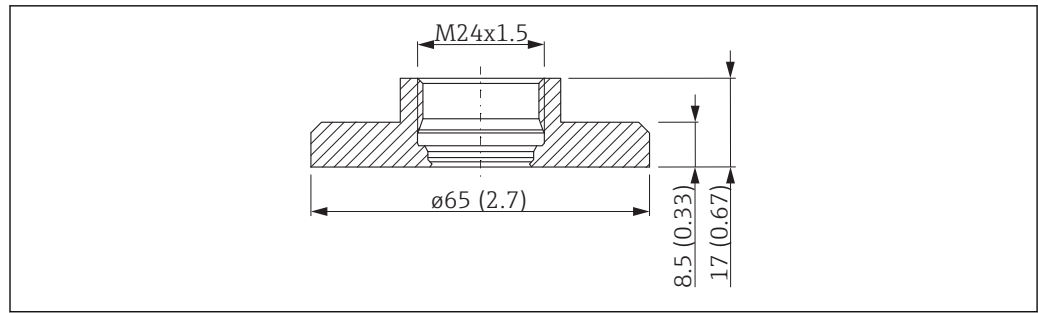

A0012776

41 Weld-in adapter for thread M24, 316L (71041381). Unit of measurement mm (in)

FMP53: Probe dimensions

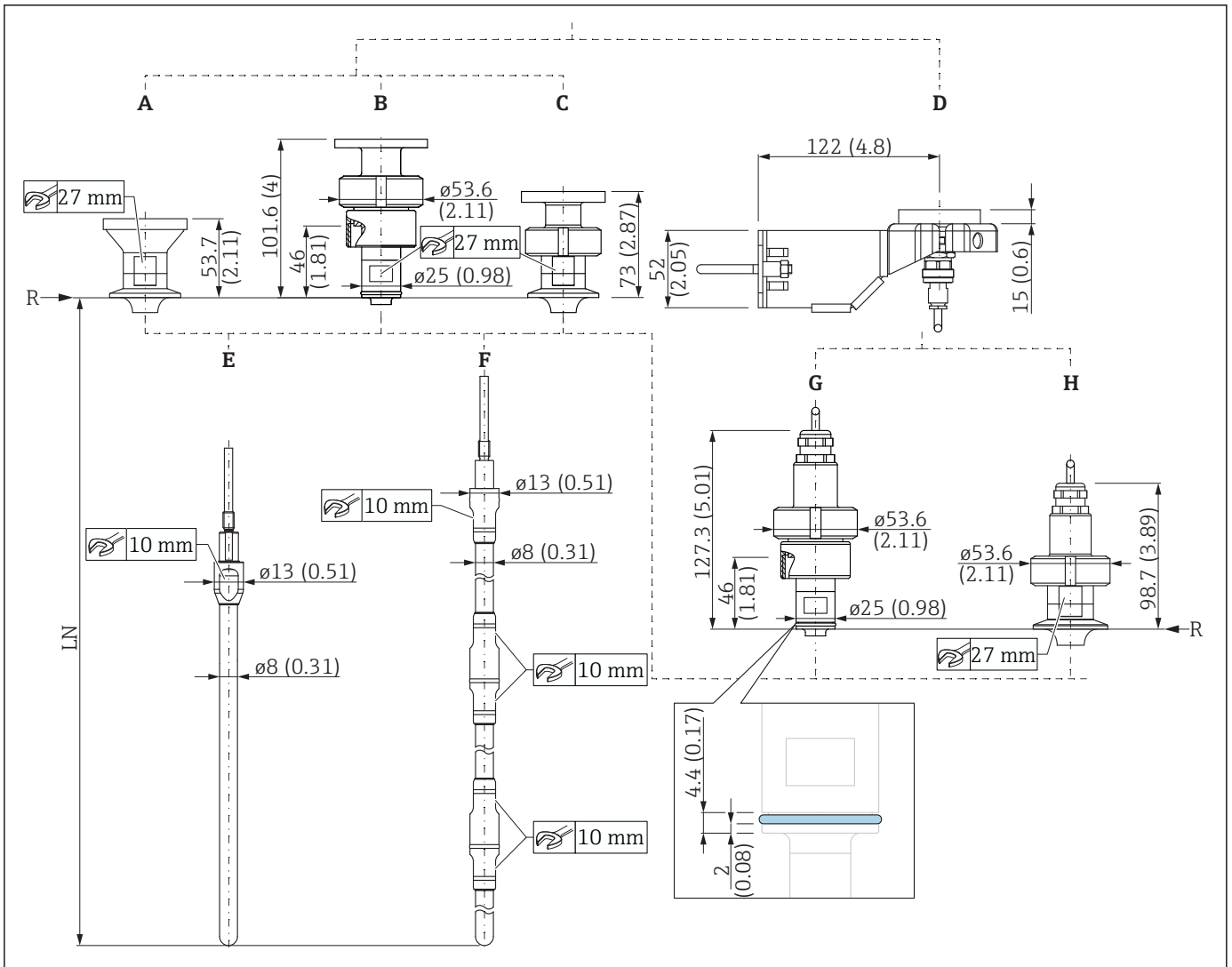

A0012762

42 FMP53: Probe. Unit of measurement mm (in)

- A Compact sensor (no option selected in feature 600)
- B Compact sensor, detachable, with Ingold fitting
- C Compact sensor, detachable (feature 600)
- D Mounting bracket for "remote sensor" sensor design (feature 600)
- E Rod probe 8mm or 1/3" (feature 060)
- F Rod probe 8mm or 1/3", 500mm or 1000mm, separable
- G Ingold fitting for "remote sensor" sensor design
- H Other process connections for "remote sensor" sensor design
- LN Probe length
- R Reference point of measurement

**i** With the NEUMO Biocontrol process connections (versions S1J, S4J and S6J), the reference point is slightly below the flange.

**Probe length tolerances****Rod probes**

Permitted tolerance depending on the probe length:

- < 1 m (3.3 ft) = +0 to -3 mm (+0 to -0.12 in)
- 1 to 4 m (3.3 to 13 ft) = +0 to -5 mm (+0 to -0.2 in)

**Weight**

*Housing*

Part	Weight
GT19 housing - plastic	Approx. 1.2 kg
GT20 housing - aluminum	Approx. 1.9 kg

*FMP53*

Part	Weight	Part	Weight
Sensor	Approx. 1.2 kg	Rod probe 8 mm	Approx. 0.4 kg/m probe length

**Materials: GT19 housing (plastic)**

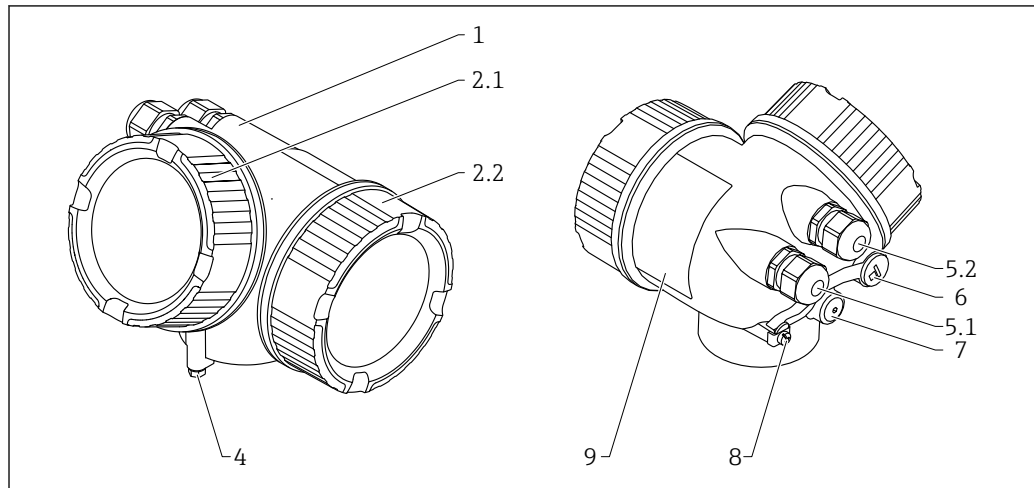

A0013788

No.	Component part	Material
1	Housing	PBT
2.1	Electronics compartment cover	<ul style="list-style-type: none"> <li>▪ Sight glass: PC</li> <li>▪ Rim: PBT-PC</li> <li>▪ Cover seal: EPDM</li> <li>▪ Thread coating: graphite-based lubricant varnish</li> </ul>
2.2	Connection compartment cover	<ul style="list-style-type: none"> <li>▪ Cover: PBT</li> <li>▪ Cover seal: EPDM</li> <li>▪ Thread coating: graphite-based lubricant varnish</li> </ul>
4	Safety device on housing neck	<ul style="list-style-type: none"> <li>▪ Screw: A4-70</li> <li>▪ Clamp: 316L (1.4404)</li> </ul>
5.1	Dummy plug, coupling, adapter or connector (depending on device version)	<ul style="list-style-type: none"> <li>▪ Dummy plug, depending on device version:                             <ul style="list-style-type: none"> <li>▪ PE</li> <li>▪ PBT-GF</li> </ul> </li> <li>▪ Coupling, depending on device version:                             <ul style="list-style-type: none"> <li>▪ Brass (CuZn), nickel-plated</li> <li>▪ PA</li> </ul> </li> <li>▪ Adapter: 316L (1.4404/1.4435)</li> <li>▪ Seal: EPDM</li> <li>▪ Connector M12: brass, nickel-plated <sup>1)</sup></li> <li>▪ Connector 7/8": 316 (1.4401) <sup>2)</sup></li> </ul>
5.2	Dummy plug, coupling or adapter (depending on device version)	<ul style="list-style-type: none"> <li>▪ Dummy plug, depending on device version:                             <ul style="list-style-type: none"> <li>▪ PE</li> <li>▪ PBT-GF</li> <li>▪ Steel, galvanized</li> </ul> </li> <li>▪ Coupling, depending on device version:                             <ul style="list-style-type: none"> <li>▪ Brass (CuZn), nickel-plated</li> <li>▪ PA</li> </ul> </li> <li>▪ Adapter: 316L (1.4404/1.4435)</li> <li>▪ Seal: EPDM</li> </ul>
6	Dummy plug or M12 socket (depending on device version)	<ul style="list-style-type: none"> <li>▪ Dummy plug: brass (CuZn), nickel-plated</li> <li>▪ M12 socket: GD-Zn, nickel-plated</li> </ul>
7	Pressure compensation vent	Brass (CuZn), nickel-plated
8	Ground terminal	<ul style="list-style-type: none"> <li>▪ Screw: A2</li> <li>▪ Spring washer: A4</li> <li>▪ Clamp: 304 (1.4301)</li> <li>▪ Bracket: 304 (1.4301)</li> </ul>
9	Adhesive nameplate	Plastic

1) In the version with M12 connector, the seal material is Viton.

2) In the version with 7/8" connector, the seal material is NBR.

**Materials: GT20 housing  
(die-cast aluminum, powder-coated)**

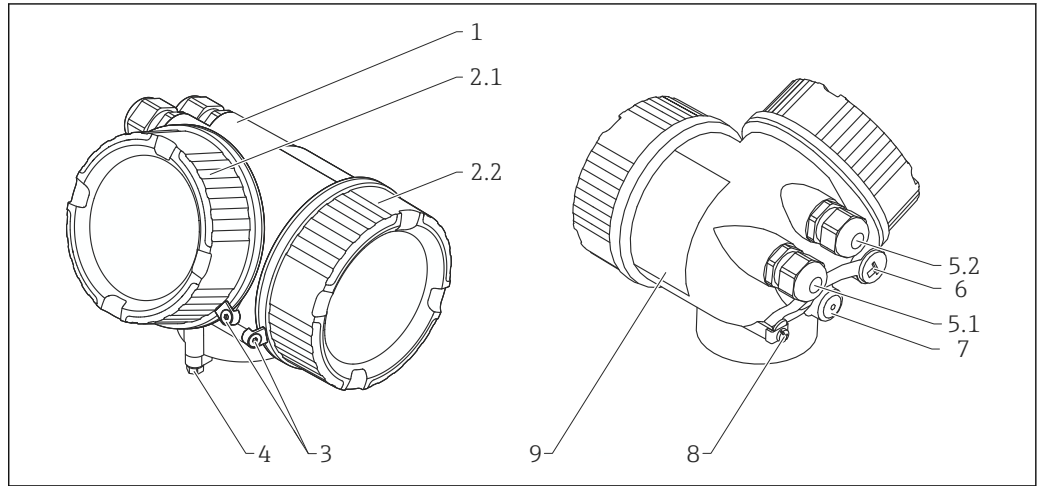

A0036037

No.	Component part	Material
1	Housing, RAL 5012 (blue)	<ul style="list-style-type: none"> <li>■ Housing: AlSi10Mg(&lt;0.1% Cu)</li> <li>■ Coating: polyester</li> </ul>
2.1	Electronics compartment cover, RAL 7035 (gray)	<ul style="list-style-type: none"> <li>■ Cover: AlSi10Mg(&lt;0.1% Cu)</li> <li>■ Window: glass</li> <li>■ Cover seal: NBR</li> <li>■ Window seal: NBR</li> <li>■ Thread coating: graphite-based lubricant varnish</li> </ul>
2.2	Connection compartment cover, RAL 7035 (gray)	<ul style="list-style-type: none"> <li>■ Cover: AlSi10Mg(&lt;0.1% Cu)</li> <li>■ Cover seal: NBR</li> <li>■ Thread coating: graphite-based lubricant varnish</li> </ul>
3	Cover clamp	<ul style="list-style-type: none"> <li>■ Screw: A4</li> <li>■ Clamp: 316L (1.4404)</li> </ul>
4	Safety device on housing neck	<ul style="list-style-type: none"> <li>■ Screw: A4-70</li> <li>■ Clamp: 316L (1.4404)</li> </ul>
5.1	Dummy plug, coupling, adapter or connector (depending on device version)	<ul style="list-style-type: none"> <li>■ Dummy plug, depending on device version:                             <ul style="list-style-type: none"> <li>■ PE</li> <li>■ PBT-GF</li> </ul> </li> <li>■ Coupling, depending on device version:                             <ul style="list-style-type: none"> <li>■ Brass (CuZn), nickel-plated</li> <li>■ PA</li> </ul> </li> <li>■ Adapter: 316L (1.4404/1.4435)</li> <li>■ Seal: EPDM</li> <li>■ M12 plug: brass, nickel-plated <sup>1)</sup></li> <li>■ 7/8" plug: 316 (1.4401) <sup>2)</sup></li> </ul>
5.2	Dummy plug, coupling or adapter (depending on device version)	<ul style="list-style-type: none"> <li>■ Dummy plug, depending on device version:                             <ul style="list-style-type: none"> <li>■ PE</li> <li>■ PBT-GF</li> <li>■ Steel, galvanized</li> </ul> </li> <li>■ Coupling, depending on device version:                             <ul style="list-style-type: none"> <li>■ Brass (CuZn), nickel-plated</li> <li>■ PA</li> </ul> </li> <li>■ Adapter: 316L (1.4404/1.4435)</li> <li>■ Seal: EPDM</li> </ul>
6	Dummy plug or M12 socket (depending on device version)	<ul style="list-style-type: none"> <li>■ Dummy plug: brass (CuZn), nickel-plated</li> <li>■ M12 socket: GD-Zn, nickel-plated</li> </ul>
7	Pressure compensation vent	Brass (CuZn), nickel-plated

---

No.	Component part	Material
8	Ground terminal	<ul style="list-style-type: none"><li>▪ Screw: A2</li><li>▪ Spring washer: A2</li><li>▪ Clamp: 304 (1.4301)</li><li>▪ Bracket: 304 (1.4301)</li></ul>
9	Adhesive nameplate	Plastic

- 1) In the version with the M12 plug, the seal material is Viton (different from standard).
- 2) In the version with the 7/8" plug, the seal material is NBR (different from standard).

**Materials: Process connection**

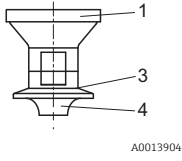
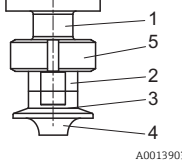
Levelflex FMP53				
Separable sensor	Non-separable sensor	No.	Material	Approval
		1	304 (1.4301)	—
		2	304 (1.4301)	—
		3	316L (1.4435)	—
		4	Ketron LSG PEEK Food Grade natural	FDA, 3A, USP Cl. VI
		5	304L (1.4307)	—

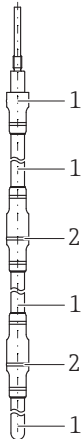
Levelflex FMP53		
Feature 060 "Probe"	No.	Material
<ul style="list-style-type: none"> <li>▪ DA: rod 8mm</li> <li>▪ DB: rod 0.31in</li> <li>▪ EA: rod 8mm, electropolished</li> <li>▪ EB: rod 0.31in, electropolished</li> </ul>		
<ul style="list-style-type: none"> <li>▪ FA: rod 8mm, 500mm separable</li> <li>▪ FB: rod 0.31in, 20in separable</li> <li>▪ GA: rod 8mm, 500mm separable, electropolished</li> <li>▪ GB: rod 0.31in, 20in separable, electropolished</li> <li>▪ HA: rod 8mm, 1000mm separable</li> <li>▪ HB: rod 0.31in, 40in separable</li> <li>▪ IA: rod 8mm, 1000mm separable, electropolished</li> <li>▪ IB: rod 0.31in, 40in separable, electropolished</li> </ul>		
 <p style="text-align: right; font-size: small;">A0013872</p>	<p>1</p> <p>316L (1.4435)</p> <ul style="list-style-type: none"> <li>▪ 0.76 µm (30 µin) mechanically polished</li> <li>▪ 0.38 µm (15 µin) electropolished</li> </ul>	
	2	O-ring (same as sensor)
 <p style="text-align: right; font-size: small;">A0013873</p>		

**Materials: Mounting bracket**

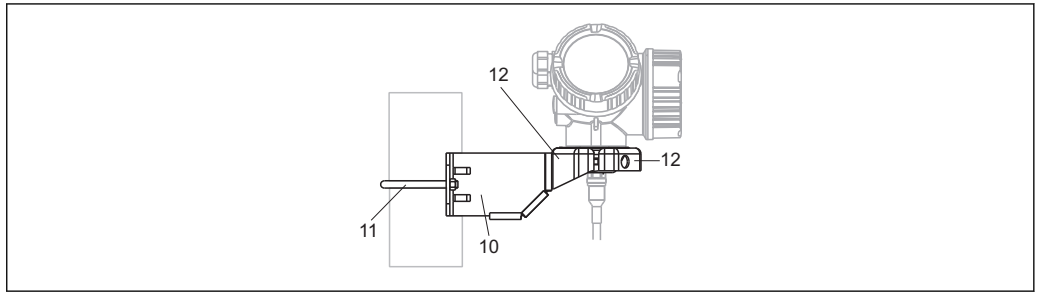

A0015143

Mounting bracket for "remote sensor" version		
No.	Component part	Material
10	Holder	316L (1.4404)
11	Round bracket	316Ti (1.4571)
	Screws/nuts	A4-70
	Distance sleeves	316Ti (1.4571) or 316L (1.4404)
12	Half-shells	316L (1.4404)

**Materials: Adapter and cable for remote sensor**

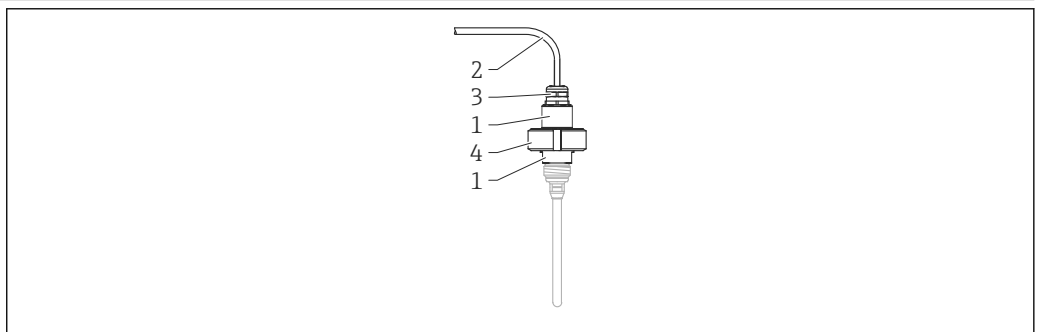

A0024684

Adapter and cable for "remote sensor" version		
No.	Component part	Material
1	Adapter (separable)	304 (1.4301)
2	Cable	FEP
3	Cable gland	CuZn nickel-plated
4	Slotted nut	304 (1.4301)

**Materials: Weather protection cover**

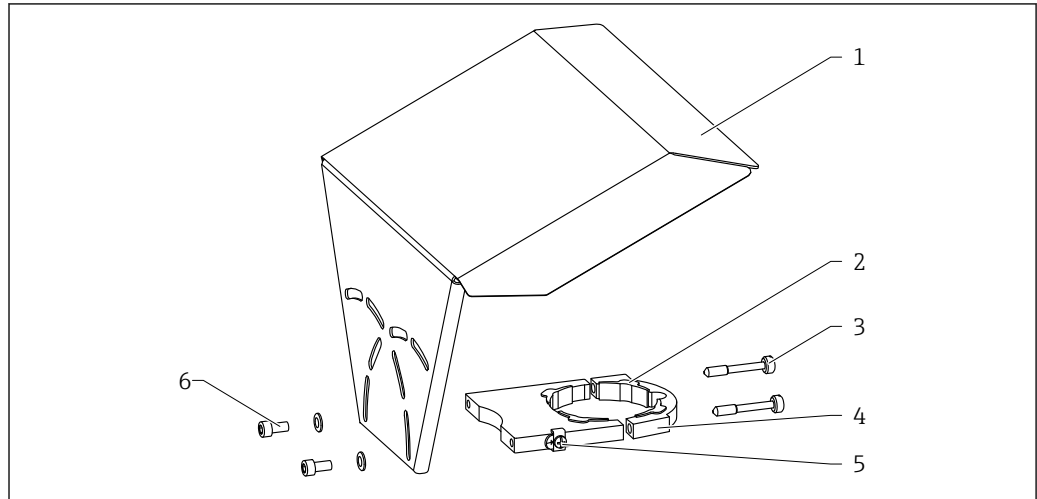

A0015473

No.	Component: Material
1	Protection cover: 316L (1.4404)
2	Rubber molded part (4x): EPDM
3	Tensioning screw: 316L (1.4404) + carbon thread
4	Holder: 316L (1.4404)
5	Ground terminal <ul style="list-style-type: none"> <li>▪ Screw: A4</li> <li>▪ Spring washer: A4</li> <li>▪ Clamp: 316L (1.4404)</li> <li>▪ Bracket: 316L (1.4404)</li> </ul>
6	<ul style="list-style-type: none"> <li>▪ Washer: A4</li> <li>▪ Cylinder screw: A4-70</li> </ul>

## Operability

### Operating concept

#### Operator-oriented menu structure for user-specific tasks

- Commissioning
- Operation
- Diagnostics
- Expert level

#### Operating languages

- English
- Deutsch
- Français
- Español
- Italiano
- Nederlands
- Portuguesa
- Polski
- русский язык (Russian)
- Svenska
- Türkçe
- 中文 (Chinese)
- 日本語 (Japanese)
- 한국어 (Korean)
- Bahasa Indonesia
- tiếng Việt (Vietnamese)
- čeština (Czech)



Feature 500 of the product structure determines which of these languages is preset on delivery.

#### Quick and save commissioning

- Interactive wizard with graphical interface for easy commissioning via FieldCare/DeviceCare
- Menu guidance with brief explanations of the individual parameter functions
- Standardized operation at the device and in the operating tools

#### Integrated data storage device (HistoROM)

- Enables transfer of configuration when changing electronic modules
- Records up to 100 event messages in the device
- Records up to 1000 measured values in the device
- Saves the signal curve on commissioning which can later be used as a reference.

#### Efficient diagnostics increase measurement reliability

- Remedy information is integrated in plain text
- Diverse simulation options and line recorder functions

#### Integrated Bluetooth module (option for HART devices)

- Easy and fast setup via SmartBlue (app)
- No additional tools or adapters required
- Signal curve via SmartBlue (app)
- Encrypted single point-to-point data transmission (Fraunhofer-Institut, third party, tested) and password-protected communication via Bluetooth® wireless technology

Local operation

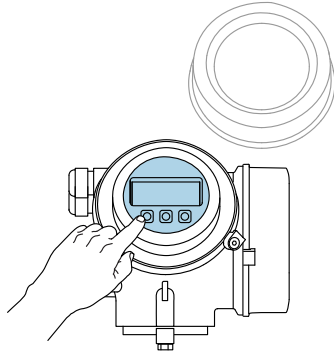
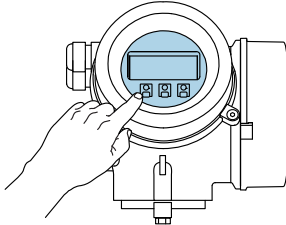
Operation with	Pushbuttons	Touch Control
Order code for "Display; Operation"	Option C "SD02"	Option E "SD03"
		
Display elements	4-line display	4-line display white background lighting; switches to red in event of device error
	Format for displaying measured variables and status variables can be individually configured	
	Permitted ambient temperature for the display: -20 to +70 °C (-4 to +158 °F) The readability of the display may be impaired at temperatures outside the temperature range.	
Operating elements	local operation with 3 push buttons (⊕, ⊖, ⏻)	external operation via touch control; 3 optical keys: ⊕, ⊖, ⏻
	Operating elements also accessible in various hazardous areas	
Additional functionality	Data backup function The device configuration can be saved in the display module.	
	Data comparison function The device configuration saved in the display module can be compared to the current device configuration.	
	Data transfer function The transmitter configuration can be transmitted to another device using the display module.	

Operation with remote display and operating module FHX50

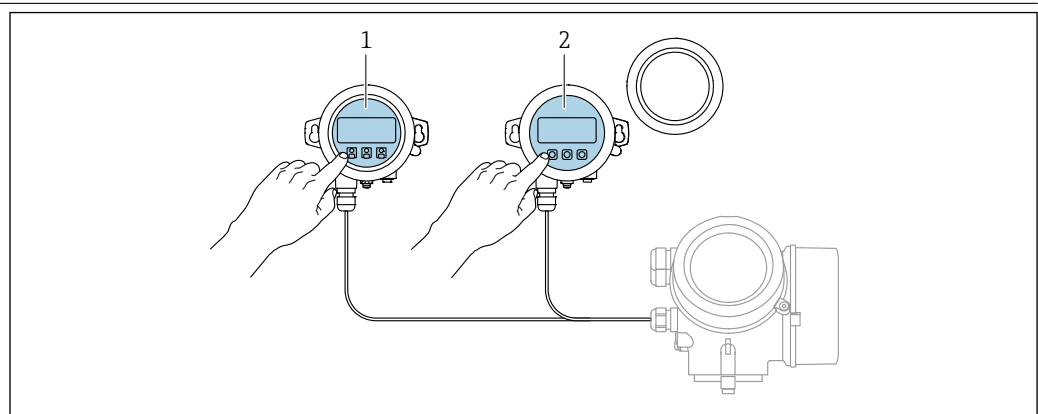

43 FHX50 operating options

- 1 Display and operating module SD03, optical keys; can be operated through the glass of the cover
- 2 Display and operating module SD02, push buttons; cover must be removed

**Operation via Bluetooth® wireless technology**

**Requirements**

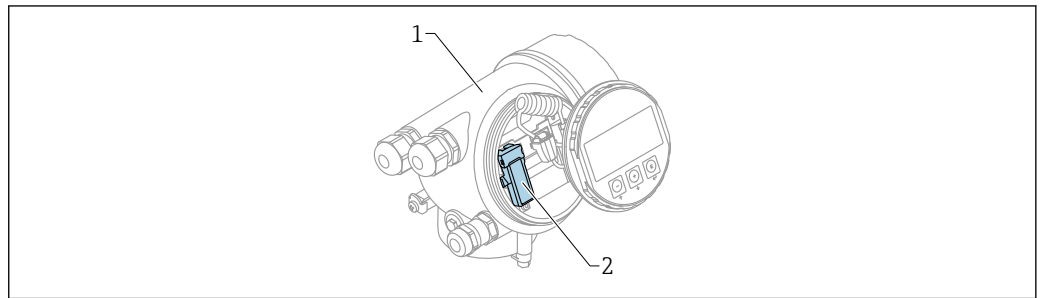

A0036790

44 Device with Bluetooth module

- 1 Electronics housing of the device
- 2 Bluetooth module

This operation option is only available for devices with Bluetooth module. There are the following options:

- The device has been ordered with a Bluetooth module: Feature 610 "Accessory Mounted", option NF "Bluetooth"
- The Bluetooth module has been ordered as an accessory (ordering number: 71377355) and has been mounted. See Special Documentation SD02252F.

**Operation via SmartBlue (app)**

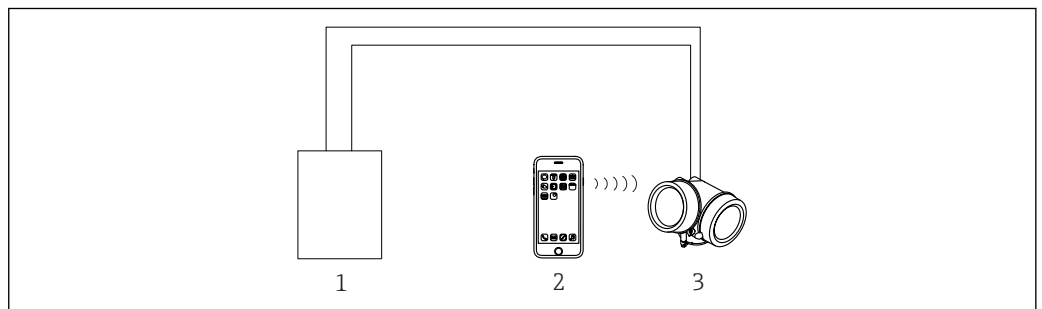

A0034939

45 Operation via SmartBlue (app)

- 1 Transmitter power supply unit
- 2 Smartphone / tablet with SmartBlue (app)
- 3 Transmitter with Bluetooth module

Remote operation

Via HART protocol

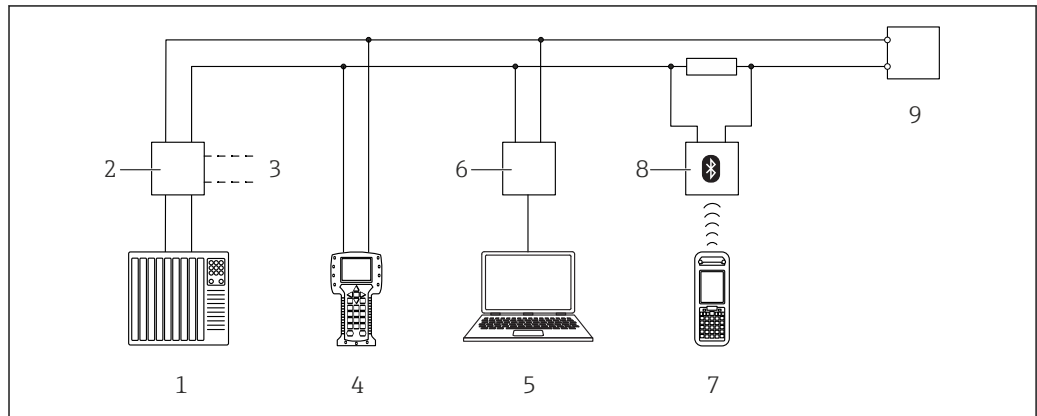

A0036169

46 Options for remote operation via HART protocol

- 1 PLC (Programmable Logic Controller)
- 2 Transmitter power supply unit, e.g. RN221N (with communication resistor)
- 3 Connection for Commubox FXA191, FXA195 and Field Communicator 375, 475
- 4 Field Communicator 475
- 5 Computer with operating tool (e.g. DeviceCare/FieldCare, AMS Device Manager, SIMATIC PDM)
- 6 Commubox FXA191 (RS232) or FXA195 (USB)
- 7 Field Xpert SFX350/SFX370
- 8 VIATOR Bluetooth modem with connecting cable
- 9 Transmitter

Via PROFIBUS PA protocol

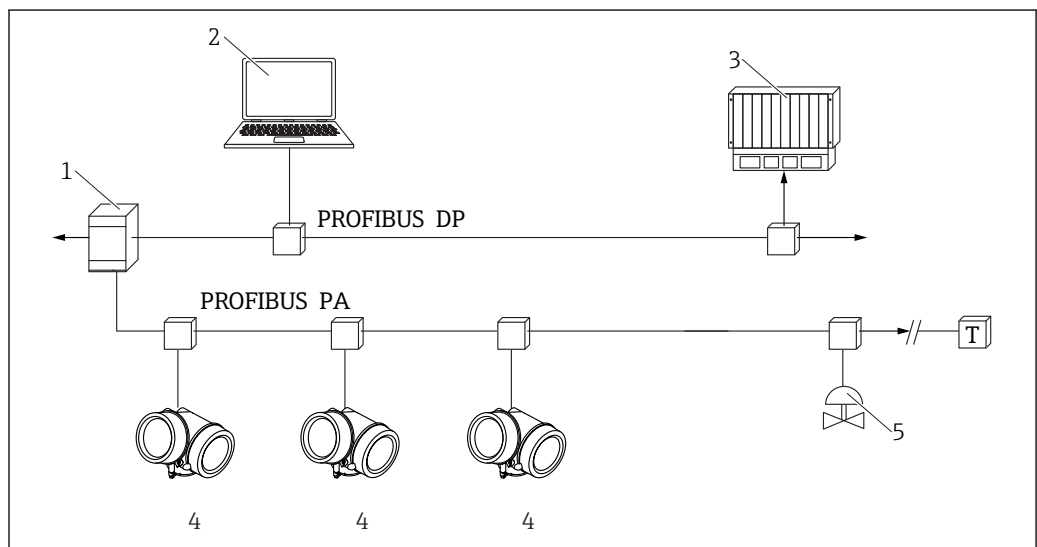

A0036301

47 Options for remote operation via PROFIBUS PA protocol

- 1 Segment coupler
- 2 Computer with Profiboard/Proficard and operating tool (e.g. DeviceCare/FieldCare)
- 3 PLC (Programmable Logic Controller)
- 4 Transmitter
- 5 Additional functions (valves etc.)

Via FOUNDATION Fieldbus

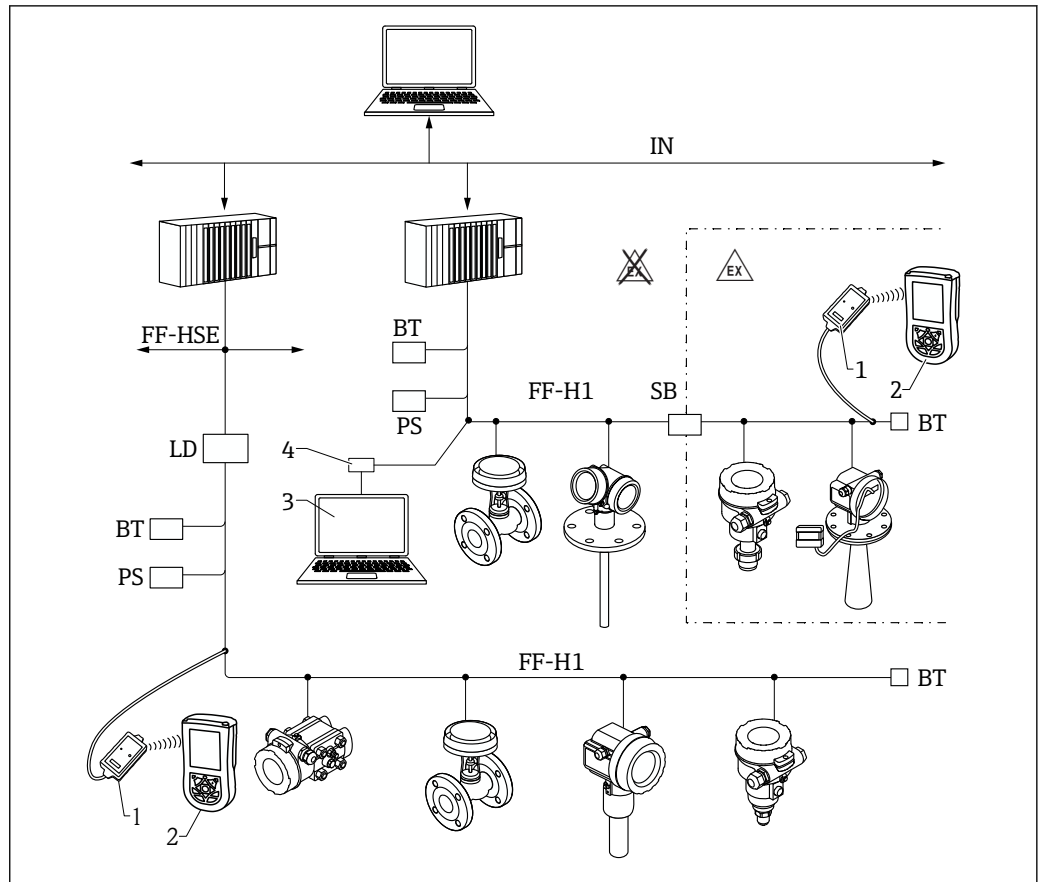

A0017188

48 FOUNDATION Fieldbus system architecture with associated components

- 1 FFblue Bluetooth modem
- 2 Field Xpert SFX350/SFX370
- 3 DeviceCare/FieldCare
- 4 NI-FF interface card

IN	Industrial network
FF-HSE	High Speed Ethernet
FF-H1	FOUNDATION Fieldbus-H1
LD	Linking Device FF-HSE/FF-H1
PS	Bus Power Supply
SB	Safety Barrier
BT	Bus Terminator

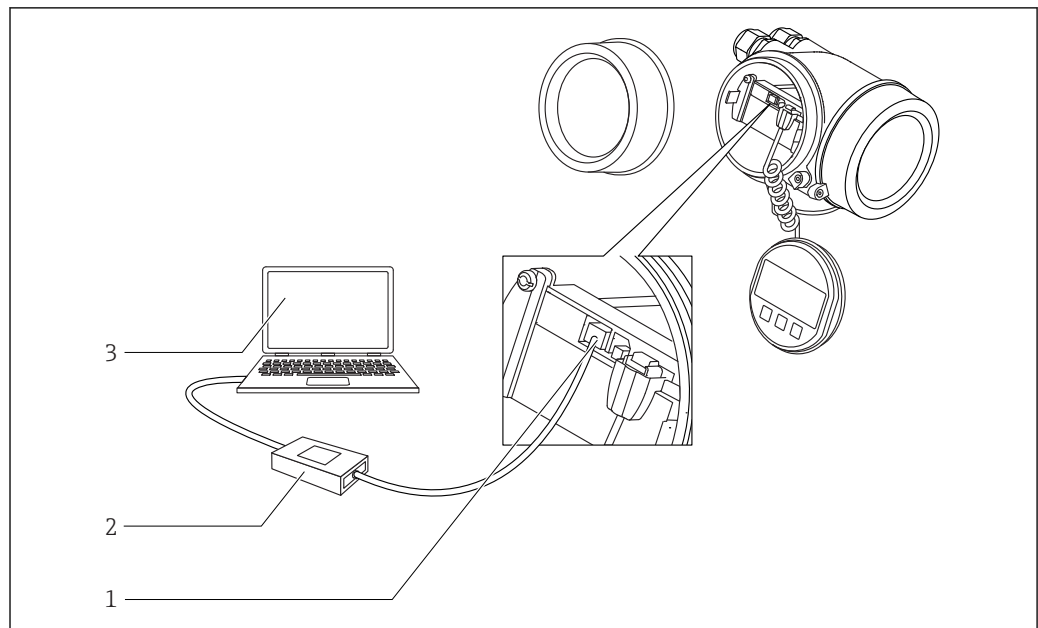
**DeviceCare/FieldCare via service interface (CDI)**

A0032466

49 DeviceCare/FieldCare via service interface (CDI)

- 1 Service interface (CDI) of the instrument (= Endress+Hauser Common Data Interface)
- 2 Commubox FXA291
- 3 Computer with DeviceCare/FieldCare operating tool

**Integration in tank gauging system**

The Endress+Hauser Tank Side Monitor NRF81 provides integrated communications for sites with multiple tanks, each with one or more sensors on the tank, such as radar, spot or average temperature, capacitive probe for water detection and/or pressure sensors. Multiple protocols out of the Tank Side Monitor guarantee connectivity to nearly any of the existing industry standard tank gauging protocols. Optional connectivity of analog 4...20 mA sensors, digital I/O and analog output simplify full tank sensor integration. Use of the proven concept of the intrinsically safe HART bus for all on-tank sensors yields extremely low wiring costs, while at the same time providing maximum safety, reliability and data availability.

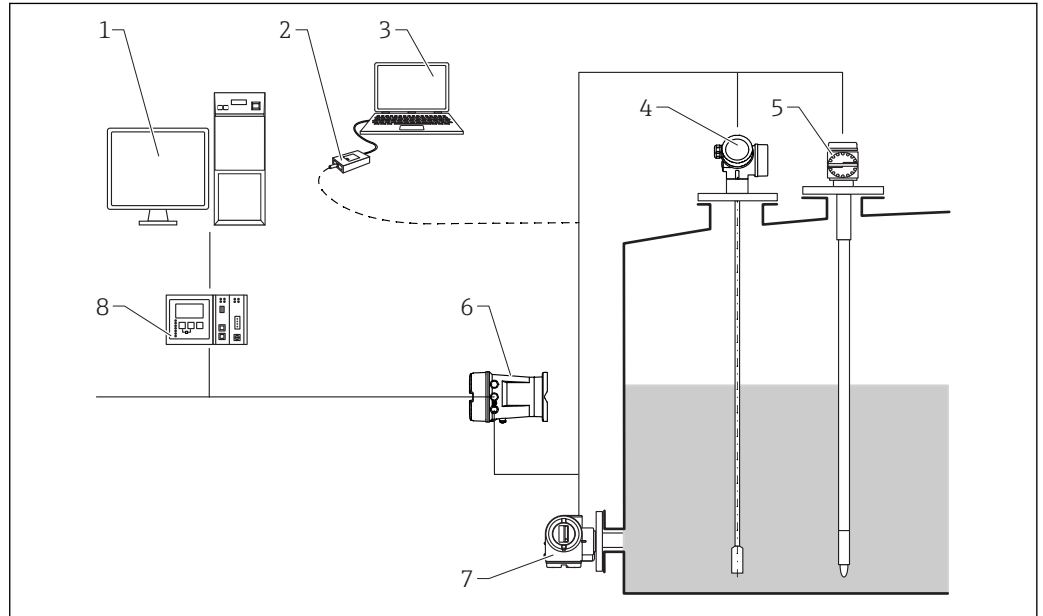

A0016590

50 The complete measuring system consists of:

- 1 Tankvision workstation
- 2 Commubox FXA195 (USB) - optional
- 3 Computer with operating tool (ControlCare) - optional
- 4 Level measuring device
- 5 Temperature measuring device
- 6 Tank Side Monitor NRF81
- 7 Pressure measuring device
- 8 Tankvision Tank Scanner NXA820

---

**SupplyCare inventory management software**

SupplyCare is a web-based operating program for coordinating the flow of material and information along the supply chain. SupplyCare provides a comprehensive overview of the levels of geographically distributed tanks and silos, for instance, providing complete transparency over the current inventory situation, regardless of time and location.

Based on the measuring and transmission technology installed onsite, the current inventory data are collected and sent to SupplyCare. Critical levels are clearly indicated and calculated forecasts provide additional security for material requirements planning.

The main functions of SupplyCare:

**Inventory visualization**

SupplyCare determines the inventory levels in tanks and silos at regular intervals. It displays current and historical inventory data and calculated forecasts of future demand. The overview page can be configured to suit the user's preferences.

**Master data management**

With SupplyCare you can create and manage the master data for locations, companies, tanks, products and users, as well as user authorization.

**Report Configurator**

The Report Configurator can be used to create personalized reports quickly and easily. The reports can be saved in a variety of formats, such as Excel, PDF, CSV and XML. The reports can be transmitted in many ways, such as by http, ftp or e-mail.

**Event management**

Events, such as when levels drop below the safety stock level or plan points, are indicated by the software. In addition, SupplyCare can also notify pre-defined users by e-mail.

**Alarms**

If technical problems occur, e.g. connection issues, alarms are triggered and alarm e-mails are sent to the System Administrator and the Local System Administrator.

**Delivery planning**

The integrated delivery planning function automatically generates an order proposal if a pre-set minimum inventory level is undershot. Scheduled deliveries and disposals are monitored continuously by SupplyCare. SupplyCare notifies the user if scheduled deliveries and disposals are not going to be met as planned.

**Analysis**

In the Analysis module, the most important indicators for the inflow and outflow of the individual tanks are calculated and displayed as data and charts. Key indicators of material management are automatically calculated and form the basis for optimizing the delivery and storage process.

**Geographical visualization**

All the tanks and the tank inventories are represented graphically on a map (based on Google Maps). The tanks and inventory situations can be filtered by tank group, product, supplier or location.

**Multi-language support**

The multi-language user interface supports 9 languages, thereby enabling global collaboration on a single platform. The language and settings are recognized automatically using the browser settings.

**SupplyCare Enterprise**

SupplyCare Enterprise runs by default as a service under Microsoft Windows on an application server in an Apache Tomcat environment. The operators and administrators operate the application via a Web browser from their workstations.

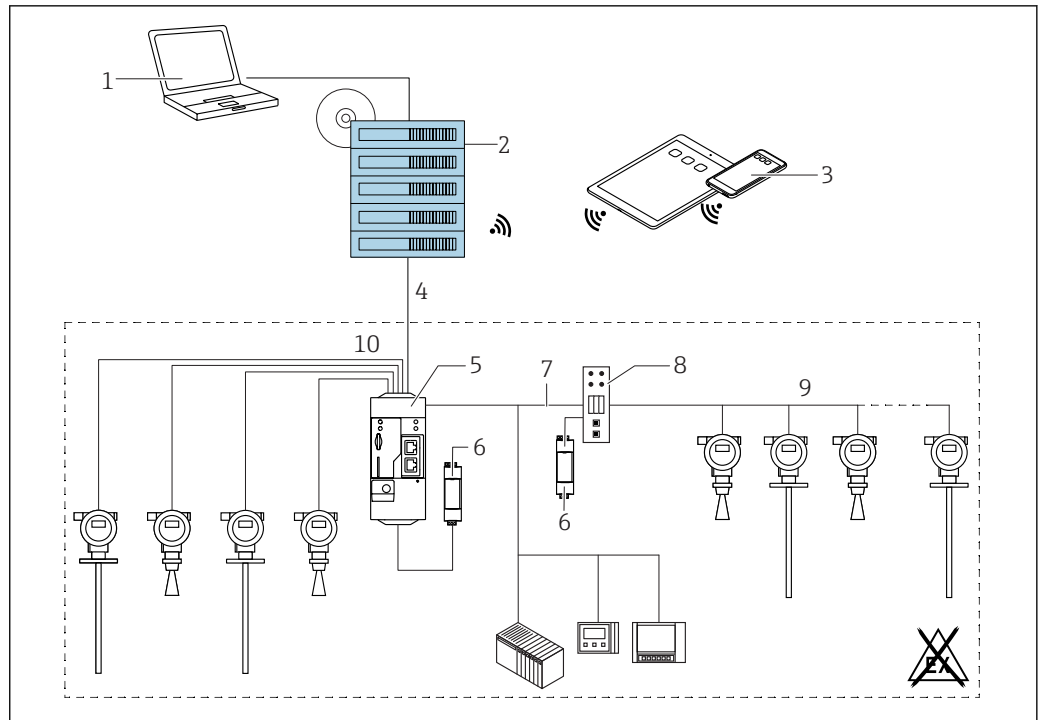

A0034288

51 Example of inventory management platform with SupplyCare Enterprise SCE30B

- 1 SupplyCare Enterprise (via Web browser)
- 2 SupplyCare Enterprise installation
- 3 SupplyCare Enterprise on mobile devices (via Web browser)
- 4 Ethernet/WLAN/UMTS
- 5 Fieldgate FXA42
- 6 Power supply 24 V DC
- 7 Modbus TCP via Ethernet as server/client
- 8 Converter from Modbus to HART Multidrop
- 9 HART Multidrop
- 10 4 x 4 to 20 mA analog input (2-wire/4-wire)

### Cloud-based application: SupplyCare Hosting

SupplyCare Hosting is offered as a hosting service (software as a service). Here, the software is installed within the Endress+Hauser IT infrastructure and made available to the user in the Endress+Hauser portal.

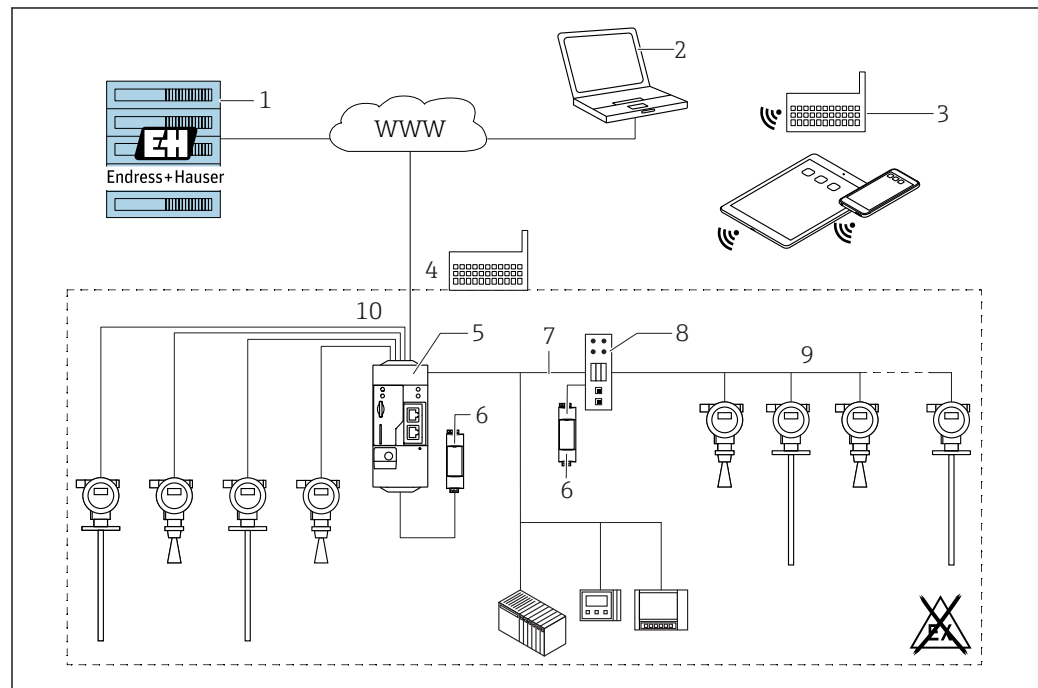

A0034289

52 Example of inventory management platform with SupplyCare Hosting SCH30

- 1 SupplyCare Hosting installation in Endress+Hauser data center
- 2 PC workstation with Internet connection
- 3 Warehouse locations with Internet connection via 2G/3G with FXA42 or FXA30
- 4 Warehouse locations with Internet connection with FXA42
- 5 Fieldgate FXA42
- 6 Power supply 24 V DC
- 7 Modbus TCP via Ethernet as server/client
- 8 Converter from Modbus to HART Multidrop
- 9 HART Multidrop
- 10 4 x 4 to 20 mA analog input (2-wire/4-wire)

With SupplyCare Hosting, users do not need to make the initial software purchase or install and run the IT infrastructure needed. Endress+Hauser constantly update SupplyCare Hosting and enhance the capability of the software in conjunction with the customer. The hosted version of SupplyCare is thus always up-to-date and can be customized to meet different customer requirements. Other services are also offered in addition to the IT infrastructure and the software that is installed in a secure, redundant Endress+Hauser data center. These services include defined availability of the global Endress+Hauser Service and Support Organization and defined response times in a service event.

## Certificates and approvals

 Currently available certificates and approvals can be called up via the product configurator.

**CE mark** The measuring system meets the legal requirements of the applicable EU Directives. These are listed in the corresponding EU Declaration of Conformity along with the standards applied.  
Endress+Hauser confirms successful testing of the device by affixing to it the CE mark.

**RoHS** The measuring system complies with the substance restrictions of the Restriction on Hazardous Substances Directive 2011/65/EU (RoHS 2).

**RCM-Tick marking** The supplied product or measuring system meets the ACMA (Australian Communications and Media Authority) requirements for network integrity, interoperability, performance characteristics as well as health and safety regulations. Here, especially the regulatory arrangements for electromagnetic compatibility are met. The products are labelled with the RCM- Tick marking on the name plate.



A0029561

**Ex approval** The devices are certified for use in hazardous areas and the relevant safety instructions are provided in the separate "Safety Instructions" (XA, ZD) document. Reference is made to this document on the nameplate.

 The separate "Safety Instructions" documentation (XA) containing all the relevant explosion protection data is available from your Endress+Hauser sales organization.

**Dual seal according to ANSI/ISA 12.27.01** The devices have been designed according to ANSI/ISA 12.27.01 as dual seal devices, allowing the user to waive the use and save the cost of installing external secondary process seals in the conduit as required by the process sealing sections of ANSI/NFPA 70 (NEC) and CSA 22.1 (CEC) These instruments comply with the North-American installation practice and provide a very safe and cost-saving installation for pressurized applications with hazardous fluids.

Further information can be found in the Safety Instructions (XA) of the relevant devices.

**Functional safety** Use for level monitoring (MIN, MAX, range) up to SIL 3 (homogeneous redundancy), independently evaluated by TÜV Rheinland in accordance with IEC 61508, refer to the "Functional Safety Manual" SD00326F for more information.

**Overfill prevention** **WHG**  
DIBt Z-65.16-501

**Hygienic compatibility** Information regarding device versions that meet the requirements of 3A Sanitary Standard No. 74 and/or are certified by the EHEDG:

 SD02503F

 Suitable fittings and seals must be used to ensure hygiene-compliant design according to 3A and EHEDG specifications.

Comply with the maximum permitted temperature of the process seal.

The gap-free connections can be cleaned of all residue using the typical cleaning methods within this industry (CIP and SIP).

**ASME BPE (CoC)** **Certificate of Compliance (CoC)**

- Product structure, feature 590 "Additional approval", version "LW"
- Wetted materials made of 316L with delta ferrite < 3 %
- Surface roughness  $R_a < 0.38 \mu\text{m}$  (15  $\mu\text{in}$ )
- Information regarding ASME BPE conformity

---

<b>Pressure equipment with allowable pressure ≤ 200 bar (2 900 psi)</b>	<p>Pressure instruments with a flange and threaded boss that do not have a pressurized housing do not fall within the scope of the Pressure Equipment Directive, irrespective of the maximum allowable pressure.</p> <p><b>Reasons:</b></p> <p>According to Article 2, point 5 of EU Directive 2014/68/EU, pressure accessories are defined as "devices with an operational function and having pressure-bearing housings".</p> <p>If a pressure instrument does not have a pressure-bearing housing (no identifiable pressure chamber of its own), there is no pressure accessory present within the meaning of the Directive.</p>
<b>Radio approval</b>	<p>Satisfies "Part 15" of the FCC rules for an unintentional radiator. All probes meet the requirements for a Class A digital device.</p> <p>In addition, coax probes and all probes in metal vessels meet the requirements for a Class B digital device.</p>
<b>Experience</b>	<p>FMP5x is the upgrade model of the FMP4x series.</p>

---

**Test, certificate**

Feature 580 "Test, certificate"	Designation	Approval
JA	3.1 Material documentation, wetted metal parts, EN10204-3.1 inspection certificate	FMP53
KB	Surface finish measurement ISO4287/Ra, wetted metal parts, inspection certificate	FMP53
KE	Pressure test, internal procedure, inspection certificate	FMP53
CF	3.1 Material certificate + Delta-Ferrite measurement, internal procedure, wetted metal parts, inspection certificate	FMP53



Test reports, declarations and inspection certificates are available in electronic format in the *W@M Device Viewer*:

Enter the serial number that appears on the device ([www.endress.com/deviceviewer](http://www.endress.com/deviceviewer))

This concerns the options for the following order codes:

- 550 "Calibration"
- 580 "Test, certificate"
- 590 "Additional approval", option LW: "CoC-ASME BPE"

**Hard-copy product documentation**

Hard-copy versions of the test reports, declarations and inspection certificates can also be order via order code 570 "Service", option I7 "Hard-copy product documentation". The documents are then supplied with the product.

**Other standards and guidelines**

- EN 60529  
Degrees of protection provided by enclosures (IP code)
- EN 61010-1  
Safety requirements for electrical equipment for measurement, control and laboratory use
- IEC/EN 61326  
"Emission in accordance with Class A requirements". Electromagnetic compatibility (EMC requirements).
- NAMUR NE 21  
Electromagnetic compatibility (EMC) of industrial process and laboratory control equipment
- NAMUR NE 43  
Standardization of the signal level for the breakdown information of digital transmitters with analog output signal.
- NAMUR NE 53  
Software of field devices and signal-processing devices with digital electronics
- NAMUR NE 107  
Status classification as per NE107
- NAMUR NE 131  
Requirements for field devices for standard applications
- IEC61508  
Functional safety of safety-related electric/electronic/programmable electronic systems

## Ordering information

---

### Ordering information

Detailed ordering information is available for your nearest sales organization [www.addresses.endress.com](http://www.addresses.endress.com) or in the Product Configurator under [www.endress.com](http://www.endress.com) :

1. Click Corporate
2. Select the country
3. Click Products
4. Select the product using the filters and search field
5. Open the product page

The Configuration button to the right of the product image opens the Product Configurator.



#### **Product Configurator - the tool for individual product configuration**

- Up-to-the-minute configuration data
- Depending on the device: Direct input of measuring point-specific information such as measuring range or operating language
- Automatic verification of exclusion criteria
- Automatic creation of the order code and its breakdown in PDF or Excel output format
- Ability to order directly in the Endress+Hauser Online Shop

**3-point linearity protocol**

**i** The following points must be considered if option F3 (3-point linearity protocol) was selected in feature 550 ("Calibration").

The 3 points of the linearity protocol are defined as follows, depending on the selected probe:

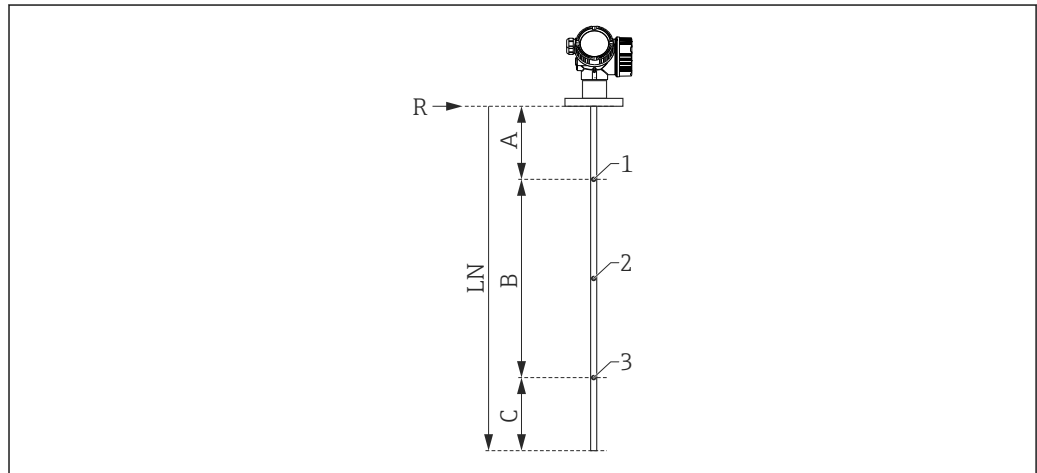

A0021090

- A Distance from the reference point R to the first measuring point
- B Measuring range
- C Distance from the probe end to the third measuring point
- LN Probe length
- R Reference point of measurement
- 1 First measuring point
- 2 Second measuring point (in the middle between the first and third measuring point)
- 3 Third measuring point

Position of 1st measuring point	A = 350 mm (13.8 in)
Position of 2nd measuring point	In the middle between the 1st and 3rd measuring point
Position of 3rd measuring point	C = 250 mm (9.84 in)
Minimum measuring range	B ≥ 400 mm (15.7 in)
Minimum probe length	LN ≥ 1000 mm (39.4 in)

**i** The position of the measuring points can vary by ±1 cm (±0.04 in).

**i** The linearity check is performed with the entire device and under reference operating conditions.

**5-point linearity protocol**

**i** The following points must be considered if option F4 (5-point linearity protocol) was selected in feature 550 ("Calibration").

The 5 points of the linearity protocol are evenly distributed over the measuring range (0% - 100%). **Empty calibration (E)** and **Full calibration (F)** must be specified in order to define the measuring range<sup>2)</sup>.

The following restrictions must be considered when selecting E and F:

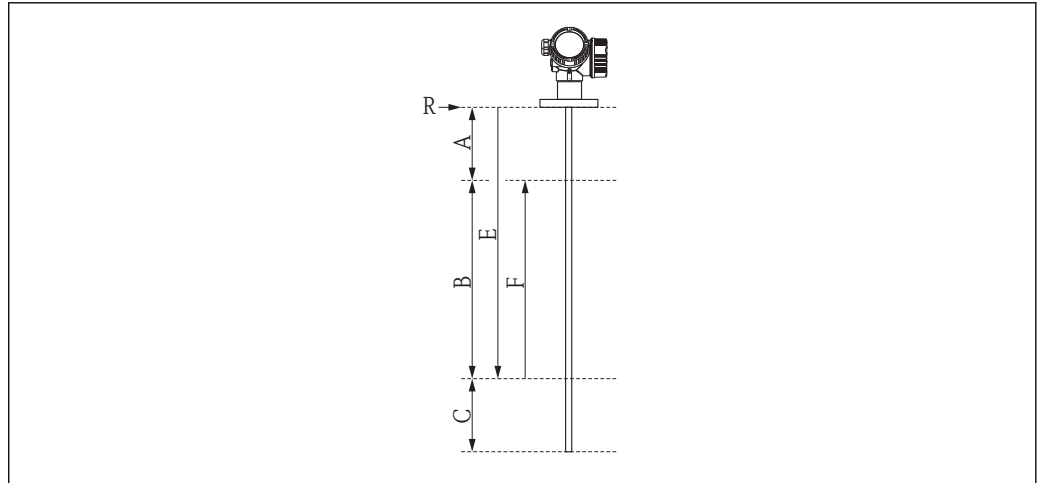

A0015167

- A Distance from the reference point R to the 100% mark
- B Measuring range
- C Distance from the probe end to the 0% mark
- E Empty calibration
- F Full calibration
- R Reference point of measurement

Sensor	Minimum distance between reference point R and 100% mark	Minimum measuring range
FMP53	A ≥ 250 mm (10 in)	B ≥ 400 mm (16 in)

Probe type	Minimum distance from the probe end to the 0% mark	Maximum value for "Empty calibration"
Rod (non-separable)	C ≥ 100 mm (4 in)	E ≤ 3.9 m (12.8 ft)
Rod (separable)	C ≥ 100 mm (4 in)	E ≤ 5.9 m (19.4 ft)

**i** The linearity check is performed with the entire device and under reference operating conditions.

**i** The selected values for **Empty calibration** and **Full calibration** are only used to create the linearity protocol. Afterwards, the values are reset to the default values specific for the probe. If values other than the default values are required, they must be ordered as a customized parameterization → 82.

2) If (E) and (F) are not specified, probe-dependent default values will be used instead.

**Customer-specific configuration**

If the option IJ: "Customized parameterization HART", IK "Customized parameterization PA" or IL "Customized parameterization FF" has been selected in feature 570 "Service", presettings that differ from the default settings can be selected for the following parameters:

Parameter	Communication protocol	Picklist / range of values
Setup → Unit of length	<ul style="list-style-type: none"> <li>■ HART</li> <li>■ PA</li> <li>■ FF</li> </ul>	<ul style="list-style-type: none"> <li>■ in</li> <li>■ ft</li> <li>■ mm</li> <li>■ m</li> </ul>
Setup → Empty calibration	<ul style="list-style-type: none"> <li>■ HART</li> <li>■ PA</li> <li>■ FF</li> </ul>	0 to 6 m (0 to 18 ft)
Setup → Full calibration	<ul style="list-style-type: none"> <li>■ HART</li> <li>■ PA</li> <li>■ FF</li> </ul>	0 to 6 m (0 to 18 ft)
Setup → Extended setup → Curr. output 1/2 → Damping	HART	0 to 999.9 s
Setup → Extended setup → Curr. output 1/2 → Failure mode	HART	<ul style="list-style-type: none"> <li>■ Min</li> <li>■ Max</li> <li>■ Last valid value</li> </ul>
Expert → Comm. → HART config. → Burst mode	HART	<ul style="list-style-type: none"> <li>■ Off</li> <li>■ On</li> </ul>

**Tagging (TAG)**

<b>Ordering feature</b>	895: Marking
<b>Option</b>	Z1: Tagging (TAG), see additional spec.
<b>Position of the measuring point marking</b>	To be selected in the additional specifications: <ul style="list-style-type: none"> <li>■ Tag plate Stainless Steel</li> <li>■ Self-adhesive paper label</li> <li>■ Supplied label/plate</li> <li>■ RFID TAG</li> <li>■ RFID TAG + Tag plate Stainless Steel</li> <li>■ RFID TAG + Self-adhesive paper label</li> <li>■ RFID TAG + Supplied label/plate</li> </ul>
<b>Definition of the measuring point designation</b>	To be defined in the additional specifications: 3 lines containing up to 18 characters each  The measuring point designation appears on the selected label and/or the RFID TAG.
<b>Designation in the Electronic Name Plate (ENP)</b>	The first 32 characters of the measuring point designation
<b>Designation on the display module</b>	The first 12 characters of the measuring point designation

## Application packages

---

### Heartbeat Diagnostics

#### Availability

Available in all device versions.

#### Function

- Continuous self-monitoring of the device.
- Diagnostic messages output to
  - the local display.
  - an asset management system (e.g. FieldCare/DeviceCare).
  - an automation system (e.g. PLC).

#### Advantages

- Device condition information is available immediately and processed in time.
- The status signals are classified in accordance with VDI/VDE 2650 and NAMUR recommendation NE 107 and contain information about the cause of the error and remedial action.

#### Detailed description

See the "Diagnostics and troubleshooting" section of the Operating Instructions for the device.

## Heartbeat Verification

### Availability

Available for the following versions of feature 540 "Application package":

- EH: Heartbeat Verification + Monitoring
- EJ: Heartbeat Verification

### Device functionality checked on demand

- Verification of the correct functioning of the measuring device within specifications.
- The verification result provides information about the condition of the device: **Passed** or **Failed**.
- The results are documented in a verification report.
- The automatically generated report supports the obligation to demonstrate compliance with internal and external regulations, laws and standards.
- Verification is possible without interrupting the process.

### Advantages

- No onsite presence is required to use the function.
- The DTM <sup>3)</sup> triggers verification in the device and interprets the results. No specific knowledge is required on the part of the user.
- The verification report can be used to prove quality measures to a third party.
- **Heartbeat Verification** can replace other maintenance tasks (e.g. periodic check) or extend the test intervals.

### SIL/WHG-locked devices <sup>4)</sup>

- The **Heartbeat Verification** module contains a wizard for the proof test which must be performed at appropriate intervals for the following applications:
  - SIL (IEC61508/IEC61511)
  - WHG (German Water Resources Act)
- To perform a proof test, the device must be locked (SIL/WHG locking).
- The wizard can be used via FieldCare, DeviceCare or a DTM-based process control system.



In the case of SIL-locked and WHG-locked devices, it is **not** possible to perform verification without taking additional measures (e.g. bridging the output current) because the output current must be simulated (Increased safety mode) or the level must be approached manually (Expert mode) during subsequent re-locking (SIL/WHG locking).

### Detailed description



SD01872F

3) DTM: Device Type Manager; controls device operation via DeviceCare, FieldCare or a DTM-based process control system.

4) Only relevant for devices with SIL or WHG approval: order code 590 ("Additional approval"), option LA ("SIL") or LC ("WHG").

## Heartbeat Monitoring

### Availability

Available for the following versions of feature 540 "Application package":  
EH: Heartbeat Verification + Monitoring

### Function

- In addition to the verification parameters, the corresponding parameter values are also logged.
- Existing measured variables, such as the echo amplitude, are used in the **Foam detection** and **Build-up detection** wizards.

 In the Levelflex FMP5x, the **Foam detection** and **Build-up detection** wizards cannot be used together.

### "Foam detection" wizard

- The Heartbeat Monitoring module contains the **Foam detection** wizard.
- This wizard is used to configure automatic foam detection, which detects foam on the product surface on the basis of the reduced signal amplitude. Foam detection can be linked to a switch output in order to control a sprinkler system, for example, which dissolves the foam.
- This wizard can be used via FieldCare, DeviceCare or a DTM-based process control system.

### "Build-up detection" wizard

- The Heartbeat Monitoring module contains the **Build-up detection** wizard.
- The wizard is used to configure automatic buildup detection, which detects the buildup of deposits on the probe on the basis of the reduced signal amplitude.
- This wizard can be used via FieldCare, DeviceCare or a DTM-based process control system.

### Advantages



- Early detection of changes (trends) to ensure plant availability and product quality.
- Use of information for the proactive planning of measures (e.g. cleaning/maintenance).
- Identification of undesirable process conditions as the basis to optimizing the facility and the processes.
- Automated control of measures to remove foam or buildup.

### Detailed description

 SDO1872F

## Accessories

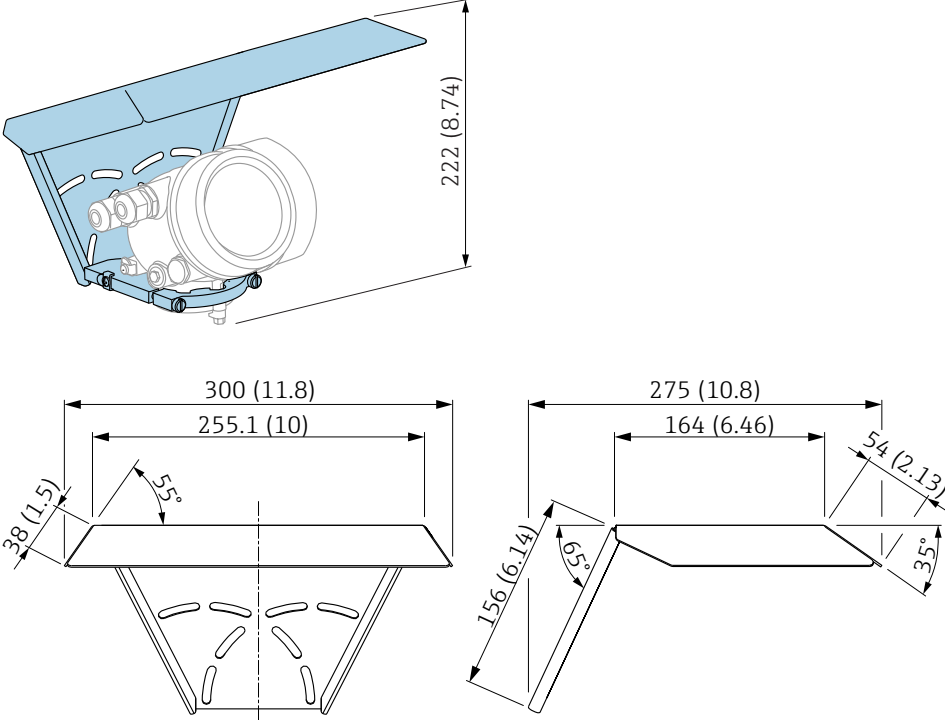
Device-specific accessories      Weather protection cover

Accessory	Description
Weather protection cover	 <p data-bbox="1380 734 1436 750">A0015466</p> <p data-bbox="1380 1146 1436 1162">A0015472</p> <p data-bbox="327 1171 837 1198">  53 Weather protection cover; Dimensions: mm (in)         </p> <p data-bbox="327 1227 1404 1310">  The weather protection cover can be ordered together with the device (product structure, feature 620 "Accessory Enclosed", option PB "Weather Protection Cover"). Alternatively, it can be separately ordered as an accessory; order code 71162242.         </p>

Mounting bracket for electronics housing

Accessories	Description
Mounting bracket for electronics housing	<div style="display: flex; justify-content: space-around;"> <div style="text-align: center;"> <p><b>A</b></p> </div> <div style="text-align: center;"> <p><b>B</b></p> </div> </div> <p> <span>■</span> 54 Mounting bracket for electronics housing; engineering unit: mm (in)                 </p> <p>                     A Wall mounting                      B Post mounting                 </p> <p> <span>■</span> With "remote sensor" device versions (see feature 060 in the product structure), the mounting bracket is included in the scope of delivery. However, it can also be ordered separately as an accessory (order number: 71102216).                 </p>

A0014793

Weld-in adapter

Accessories	Description
Weld-in adapter M24 D65	<div style="text-align: center;"> </div> <p>                     With M24x1.5 thread for flush-mounted installation of sensor.                      Material: 1.4435 (AISI 316L)                      Weight: 0.22 kg (0.48 lbs)                 </p> <p>                     Order number                 </p> <ul style="list-style-type: none"> <li>■ Standard version: 71041381</li> <li>■ With 3.1 material certificate: 71041383</li> </ul> <p>                     For details, see Operating Instructions BA361F.                 </p>

A0012776

**Protective cover**

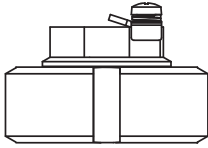
Accessories	Description
Protective cover	 <p style="text-align: right; margin-right: 20px;">A0013589</p> <p>For closing off the probe when the electronics module is removed                      Order number: 71041379                      For details, see Operating Instructions BA362F.</p>

**Calibration kit**

Accessories	Description
Calibration kit	<p>The calibration kit is used for regular testing of the accuracy and reproducibility of the Levelflex FMP53 level measurement device.                      Order number: 71041382                      For details, see Operating Instructions SD01003F.</p>

Remote display FHX50

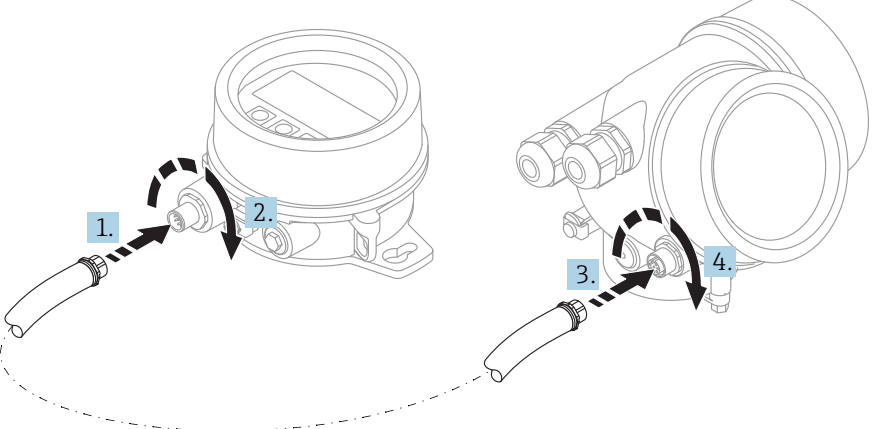





Accessories	Description
Remote display FHX50	 <p style="text-align: right;">A0019128</p> <ul style="list-style-type: none"> <li>▪ Material:             <ul style="list-style-type: none"> <li>▪ Plastic PBT</li> <li>▪ 316L/1.4404</li> <li>▪ Aluminum</li> </ul> </li> <li>▪ Degree of protection: IP68 / NEMA 6P and IP66 / NEMA 4x</li> <li>▪ Suitable for display modules:             <ul style="list-style-type: none"> <li>▪ SD02 (push buttons)</li> <li>▪ SD03 (touch control)</li> </ul> </li> <li>▪ Connecting cable:             <ul style="list-style-type: none"> <li>▪ Cable supplied with device up to 30 m (98 ft)</li> <li>▪ Standard cable supplied by customer up to 60 m (196 ft)</li> </ul> </li> <li>▪ Ambient temperature range: -40 to 80 °C (-40 to 176 °F)</li> <li>▪ Ambient temperature range (option): -50 to 80 °C (-58 to 176 °F) <sup>1)</sup></li> </ul> <p><b>i</b> ▪ If the remote display should be used, order the device version "Prepared for display FHX50" (feature 030, version L, M or N). For the FHX50, you must select option A: "Prepared for display FHX50" under feature 050 "Measuring device version".</p> <p>▪ If the device version "Prepared for display FHX50" was not originally ordered and a FHX50 display is to be retrofitted, you must select version B "Not prepared for display FHX50" under feature 050: "Measuring device version" when ordering the FHX50. In this case, a retrofit kit for the device is supplied with the FHX50. The kit can be used to prepare the device so that the FHX50 can be used.</p> <p><b>i</b> Use of the FHX50 may be restricted for transmitters with an approval. A device can only be retrofitted with the FHX50 if the option L, M or N ("Prepared for FHX50") is listed under <i>Basic specifications</i>, item 4 "Display, operation" in the Safety Instructions (XA) for the device. Also pay attention to the Safety Instructions (XA) of the FHX50.</p> <p><b>i</b> Retrofitting is not possible on transmitters with:</p> <ul style="list-style-type: none"> <li>▪ An approval for use in areas with flammable dust (dust ignition-proof approval)</li> <li>▪ Ex nA type of protection</li> </ul> <p><b>i</b> For details, see document SD01007F.</p>

1) This range is valid if option JN "Ambient temperature transmitter -50 °C (-58 °F)" has been selected in ordering feature 580 "Test, Certificate". If the temperature is permanently below -40 °C (-40 °F), failure rates may be increased.

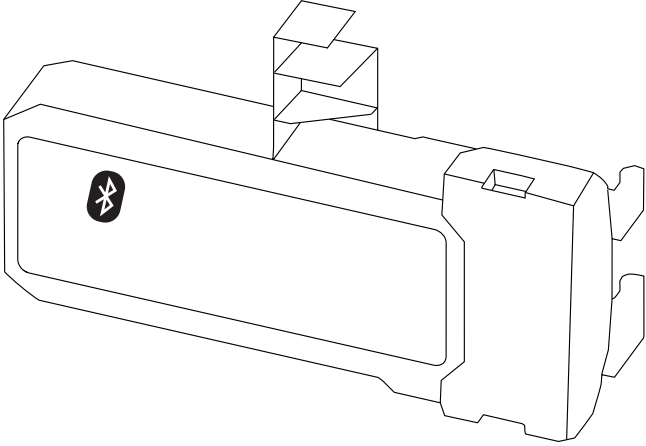
## Overvoltage protection

Accessories	Description
Overvoltage protection for 2-wire devices OVP10 (1-channel) OVP20 (2-channel)	<div data-bbox="327 320 715 651" data-label="Image"> </div> <div data-bbox="1382 663 1437 678" data-label="Text"> <p>A0021734</p> </div> <p data-bbox="327 703 469 725"><b>Technical data</b></p> <ul data-bbox="327 730 983 887" style="list-style-type: none"> <li>▪ Resistance per channel: <math>2 \times 0.5 \Omega_{\max}</math></li> <li>▪ Threshold DC voltage: 400 to 700 V</li> <li>▪ Threshold surge voltage: &lt; 800 V</li> <li>▪ Capacitance at 1 MHz: &lt; 1.5 pF</li> <li>▪ Nominal leakage current (8/20 <math>\mu</math>s): 10 kA</li> <li>▪ Suitable for conductor cross-sections: 0.2 to 2.5 mm<sup>2</sup> (24 to 14 AWG)</li> </ul> <p data-bbox="327 902 608 925"><b><span style="border: 1px solid black; padding: 0 2px;">i</span> Ordered with the device</b></p> <p data-bbox="379 927 1426 976">Ideally, the overvoltage protection module should be ordered directly with the device. See product structure, feature 610 "Accessory mounted", option NA "Overvoltage protection". Separate order necessary only if retrofitting.</p> <p data-bbox="327 992 671 1014"><b><span style="border: 1px solid black; padding: 0 2px;">i</span> Order numbers for retrofitting</b></p> <ul data-bbox="379 1016 911 1122" style="list-style-type: none"> <li>▪ For 1-channel devices (feature 020, option A): OVP10: 71128617</li> <li>▪ For 2-channel devices (feature 020, options B, C, E or G) OVP20: 71128619</li> </ul> <p data-bbox="379 1137 663 1160"><b>Housing cover for retrofitting</b></p> <p data-bbox="379 1162 1426 1238">In order to keep the necessary safety distances when using the surge arrester module, the housing cover also needs to be replaced when the device is retrofitted. Depending on the housing type, the suitable cover can be ordered using the following material number:</p> <ul data-bbox="379 1240 695 1319" style="list-style-type: none"> <li>▪ Housing GT18: cover 71185516</li> <li>▪ Housing GT19: cover 71185518</li> <li>▪ Housing GT20: cover 71185517</li> </ul> <p data-bbox="327 1335 703 1357"><b><span style="border: 1px solid black; padding: 0 2px;">i</span> Restrictions in case of retrofitting</b></p> <p data-bbox="379 1359 1417 1435">The use of the OVP module may be restricted depending on the transmitter approval. A device may only be retrofitted with the OVP module if the option NA (overvoltage protection) is listed under <i>Optional specifications</i> in the Safety Instructions (XA) associated with the device.</p> <p data-bbox="327 1451 624 1473"><b><span style="border: 1px solid black; padding: 0 2px;">i</span> For details, see SD01090F.</b></p>

Bluetooth module for HART devices

Accessory	Description
<p>Bluetooth module</p>	<div style="text-align: right; margin-bottom: 10px;">A0036493</div>  <ul style="list-style-type: none"> <li>▪ Quick and easy commissioning via SmartBlue (app)</li> <li>▪ No additional tools or adapters required</li> <li>▪ Signal curve via SmartBlue (app)</li> <li>▪ Encrypted single point-to-point data transmission (tested by Fraunhofer institute) and password protected communication via Bluetooth® wireless technology</li> <li>▪ Range under reference conditions: &gt; 10 m (33 ft)</li> </ul> <p> When using the Bluetooth module the minimum supply voltage increases by up to 3 V.</p> <p> <b>Ordering with device</b> The Bluetooth module is preferably ordered with the device. See product structure, feature 610 "Accessory Mounted", option NF "Bluetooth". A separate order is only necessary in case of retrofitting.</p> <p> <b>Order code for retrofitting</b> Bluetooth module (BT10): 71377355</p> <p> <b>Restrictions in case of retrofitting</b> Depending on the approval of the transmitter, application of the Bluetooth module may be restricted. A device may only be retrofitted with a Bluetooth module if the option <i>NF</i> (Bluetooth) is listed in the associated Safety Instructions (XA) under <i>Optional specifications</i>.</p> <p> For details refer to SD02252F.</p>

## Communication-specific accessories

### Commubox FXA195 HART

For intrinsically safe HART communication with FieldCare via the USB interface



For details, see "Technical Information" TI00404F

### Commubox FXA291

Connects Endress+Hauser field devices with a CDI interface (= Endress+Hauser Common Data Interface) and the USB port of a computer or laptop

Order number: 51516983



For details, see "Technical Information" TI00405C

### HART Loop Converter HMX50

Is used to evaluate and convert dynamic HART process variables to analog current signals or limit values

Order number: 71063562



For details, see "Technical Information" TI00429F and Operating Instructions BA00371F

### WirelessHART adapter SWA70

- Is used for the wireless connection of field devices
- The WirelessHART adapter can be easily integrated into field devices and existing infrastructures, offers data protection and transmission safety and can be operated in parallel with other wireless networks



For details, see Operating Instructions BA00061S

### Connect Sensor FXA30/FXA30B

Fully integrated, battery-powered gateway for simple applications with SupplyCare Hosting. Up to 4 field devices with 4 to 20 mA communication (FXA30/FXA30B), serial Modbus (FXA30B) or HART (FXA30B) can be connected. With its robust design and ability to run for years on the battery, it is ideal for remote monitoring in isolated locations. Version with LTE (USA, Canada and Mexico only) or 3G mobile transmission for worldwide communication.



For details, see "Technical Information" TI01356S and Operating Instructions BA01710S.

### Fieldgate FXA42

Fieldgates enable communication between connected 4 to 20 mA, Modbus RS485 and Modbus TCP devices and SupplyCare Hosting or SupplyCare Enterprise. The signals are transmitted either via Ethernet TCP/IP, WLAN or mobile communications (UMTS). Advanced automation capabilities are available, such as an integrated Web-PLC, OpenVPN and other functions.



For details, see "Technical Information" TI01297S and Operating Instructions BA01778S.

### SupplyCare Enterprise SCE30B

Inventory management software that displays the level, volume, mass, temperature, pressure, density or other parameters of tanks. The parameters are recorded and transmitted by means of gateways like Fieldgate FXA42, Connect Sensor FXA30B or other gateway types. This Web-based software is installed on a local server and can also be visualized and operated with mobile terminals such as a smartphone or tablet.



For details, see Technical Information TI01228S and Operating Instructions BA00055S

### SupplyCare Hosting SCH30

Inventory management software that displays the level, volume, mass, temperature, pressure, density or other parameters of tanks. The parameters are recorded and transmitted by means of gateways like Fieldgate FXA42, Connect Sensor FXA30B or other gateway types. SupplyCare Hosting is offered as a hosting service (Software as a Service, SaaS). In the Endress +Hauser portal, the user is provided with the data over the Internet.



For details, see Technical Information TI01229S and Operating Instructions BA00050S

### Field Xpert SFX350

Field Xpert SFX350 is a mobile computer for commissioning and maintenance. It enables efficient device configuration and diagnostics for HART and FOUNDATION Fieldbus devices in the **non-Ex area**.



For details, see Operating Instructions BA01202S

**Field Xpert SFX370**

Field Xpert SFX370 is a mobile computer for commissioning and maintenance. It enables efficient device configuration and diagnostics for HART and FOUNDATION Fieldbus devices in the **non-Ex area** and the **Ex area**.



For details, see Operating Instructions BA01202S

**Service-specific accessories**

**DeviceCare SFE100**

Configuration tool for HART, PROFIBUS and FOUNDATION Fieldbus field devices



Technical Information TI01134S

**FieldCare SFE500**

FDT-based plant asset management tool

It can configure all smart field units in your system and helps you manage them. By using the status information, it is also a simple but effective way of checking their status and condition.



Technical Information TI00028S

**System components**

**Memograph M graphic data manager**

The Memograph M graphic data manager provides information on all the relevant process variables. Measured values are recorded correctly, limit values are monitored and measuring points analyzed. The data are stored in the 256 MB internal memory and also on a SD card or USB stick.



Technical Information TI00133R and Operating Instructions BA00247R

**RN221N**

Active barrier with power supply for safe separation of 4 to 20 mA standard signal circuits. Offers bidirectional HART transmission.



Technical Information TI00073R and Operating Instructions BA00202R

**RN221**

Supply unit for powering two 2-wire measuring devices solely in the non-Ex area. Bidirectional communication is possible via the HART communication jacks.



Technical Information TI00081R and Brief Operating Instructions KA00110R

## Supplementary documentation

The following documentation types are available in the Downloads section of the Endress+Hauser website ([www.endress.com/downloads](http://www.endress.com/downloads)):



For an overview of the scope of the associated Technical Documentation, refer to the following:

- *W@M Device Viewer* ([www.endress.com/deviceviewer](http://www.endress.com/deviceviewer)): Enter the serial number from nameplate
- *Endress+Hauser Operations App*: Enter the serial number from the nameplate or scan the 2D matrix code (QR code) on the nameplate

**Brief Operating Instructions (KA)**

**Guide that takes you quickly to the 1st measured value**

The Brief Operating Instructions contain all the essential information from incoming acceptance to initial commissioning.

**Operating Instructions (BA)**

**Your reference guide**

These Operating Instructions contain all the information that is required in various phases of the life cycle of the device: from product identification, incoming acceptance and storage, to mounting, connection, operation and commissioning through to troubleshooting, maintenance and disposal.

**Safety Instructions (XA)**

Depending on the approval, the following Safety Instructions (XA) are supplied with the device. They are an integral part of the Operating Instructions.



The nameplate indicates the Safety Instructions (XA) that are relevant to the device.

---

---



71488022

[www.addresses.endress.com](http://www.addresses.endress.com)

---