

High Performance Inverter

FRENIC-Ace

CAUTION

Thank you for purchasing our multifunction FRENIC-Ace series of inverters.

- Be sure to set the destination on inverter type FRN****E2S/E2E-2G□/4G□/7G□ for the initial power supply. Without setting the destination, the inverter cannot be operated. For details, refer to 4.4 Destination setting.
- This product is designed to drive a three-phase motor under variable speed control. Read through this instruction manual and become familiar with the handling procedure for correct use.
- Improper handling might result in incorrect operation, a short life, or even a failure of this product as well as the motor.
- Deliver this manual to the end user of this product. Keep this manual in a safe place until this product is discarded.
- For how to use an optional device, refer to the instruction manual prepared for that optional device.
- This manual provides only major functions of the FRENIC-Ace series. For details, refer to the FRENIC-Ace User's Manual.

汉语版的这个文件可以从以下站点下载。

Chinese version of this document can be downloaded from the following site.

https://www.fujielectric.com.cn/document/product_operation.html

本書の日本語版は下記サイトからダウンロードできます。

Japanese version of this document can be downloaded from the following site.

<http://www.fujielectric.co.jp/products/drive-download/>

Copyright © 2015 Fuji Electric Co., Ltd.

All rights reserved.

No part of this publication may be reproduced or copied without prior written permission from Fuji Electric Co., Ltd.

All products and company names mentioned in this manual are trademarks or registered trademarks of their respective holders.

The information contained herein is subject to change without prior notice for improvement.

The purpose of this instruction manual is to provide accurate information in handling, setting up and operating of the FRENIC-Ace series of inverters. Please feel free to send your comments regarding any errors or omissions you may have found, or any suggestions you may have for generally improving the manual.

In no event will Fuji Electric Co., Ltd. be liable for any direct or indirect damages resulting from the application of the information in this manual.

Preface

Thank you for purchasing our multifunction FRENIC-Ace series of inverters. This product is designed to drive a three-phase induction motor or a three-phase permanent magnet synchronous motor under variable speed control.

This manual provides all the information on the FRENIC-Ace (Global model) series of inverters including its operating procedure and selection of peripheral equipment. Before use, carefully read this manual for proper use. Improper handling might result in incorrect operation, a short life, or even a failure of this product as well as the motor.

The table below lists the other materials related to the use of the FRENIC-Ace. Read them in conjunction with this manual if necessary.



Name	Material No.	Description
Catalog	24A1-E-0042	Product scope, features, specifications, external drawings, and options of the product
FRENIC-Ace User's Manual	24A7-E-0043	Product details control block diagrams, specifications, and external dimensions
RS-485 Communication User's Manual	24A7-E-0021*	Overview of functions implemented by using FRENIC-Ace RS-485 communications facility, its communications specifications, Modbus RTU/Fuji general-purpose inverter protocol, function codes and related data formats
User's Manual for China model.	24A7-C-0043	This manual is written in simplified Chinese.
User's Manual for Japanese model.	24A7-J-0088	This manual is written in Japanese.

*Available soon

The materials are subject to change without notice. Be sure to obtain the latest editions for use.

CONTENTS



Chapter 1	BEFORE USE	
1.1	Acceptance Inspection (Nameplates and Inverter Type).....	1-1
1.2	External View and Terminal Blocks.....	1-3
1.3	Precautions for Using Inverters	1-5
1.3.1	Usage environment	1-5
1.3.2	Storage environment	1-7
[1]	Temporary storage.....	1-7
[2]	Long-term storage	1-7
Chapter 2	INSTALLATION AND WIRING	
2.1	Installation	2-1
2.2	Wiring	2-3
2.2.1	Basic connection diagram.....	2-3
2.2.2	Removal and attachment of the front cover/ terminal cover and wiring guide	2-6
2.2.3	Precautions for wiring	2-8
2.2.4	Precautions for long wiring (between inverter and motor)	2-9
2.2.5	Main circuit terminals.....	2-11
[1]	Screw specifications.....	2-11
[2]	Terminal layout diagram (main circuit terminal).....	2-14
[3]	Recommended wire size (main circuit terminals)	2-16
[4]	Description of terminal functions (main circuit terminal).....	2-37
2.2.6	Control circuit terminals (common to all models).....	2-41
[1]	Screw specifications and recommended wire size (control circuit terminals).....	2-41
[2]	Terminal layout diagram (control circuit terminal)	2-41
[3]	Description of terminal functions (control circuit terminal)	2-42
2.2.7	Switching connector (types FRN0203E2■-4□ or above)	2-50
2.2.8	Operating slide switches.....	2-52
2.3	Attachment and Connection of Keypad	2-53
2.3.1	Parts required for connection.....	2-53
2.3.2	Attachment procedure.....	2-54
2.4	RJ-45 Cover.....	2-57
Chapter 3	OPERATION USING THE KEYPAD	
3.1	Names and Functions of Keypad Components	3-1
3.2	Overview of Operation Modes	3-3
Chapter 4	TEST RUN PROCEDURE	
4.1	Test Run Procedure Flowchart	4-1
4.2	Checking Prior to Powering On	4-2
4.3	Powering ON and Checking.....	4-3
4.4	Destination setting.....	4-4
4.5	Switching the Applicable Motor Rating (ND, HD, HND and HHD Modes).....	4-6
Chapter 5	FUNCTION CODES	
5.1	Function Codes Overview	5-1
5.2	Function Codes Table	5-1
5.2.1	Supplementary note	5-1
5.2.2	Function codes table	5-3
5.2.3	Factory default value per applicable electric motor capacitance	5-35
Chapter 6	TROUBLESHOOTING	
6.1	Protective Function	6-1

6.2	Before Proceeding with Troubleshooting	6-2
6.3	If an Alarm Code Appears on the LED Monitor.....	6-3
6.3.1	Alarm code list	6-3
Chapter 7 MAINTENANCE AND INSPECTION		
7.1	Inspection Interval	7-1
7.2	Daily Inspection.....	7-2
7.3	Periodic Inspection	7-3
7.3.1	Periodic inspection 1--Before the inverter is powered ON or after it stops running.....	7-3
7.3.2	Periodic inspection 2--When the inverter is ON or it is running.....	7-4
7.4	List of Periodic Replacement Parts.....	7-4
7.4.1	Judgment on service life.....	7-5
[1]	Measuring the capacitance of DC link bus capacitor in comparison with initial one at shipment 7-6	
[2]	Measuring the capacitance of the DC link bus capacitor under ordinary operating conditions.....	7-7
[3]	Early warning of lifetime alarm.....	7-7
7.5	Measurement of Electrical Amounts in Main Circuit.....	7-8
7.6	Insulation Test.....	7-9
7.7	Inquiries about Product and Guarantee	7-9
7.7.1	When making an inquiry.....	7-9
7.7.2	Product warranty	7-10
[1]	Free of charge warranty period and warranty range	7-10
[2]	Exclusion of liability for loss of opportunity, etc.	7-11
[3]	Repair period after production stop, spare parts supply period (holding period).....	7-11
[4]	Transfer rights.....	7-11
[5]	Service contents.....	7-11
[6]	Applicable scope of service.....	7-11
APPENDICES		
Appendix G	Conformity with Standards	1
G.1	Compliance with European Standards ().....	1
[1]	Compliance with EMC standards	1
[2]	Compliance with the low voltage directive in the EU.....	6
G.2	Harmonic Component Regulation in the EU.....	13
[1]	General comments.....	13
[2]	Compliance with the harmonic component regulation	13
G.3	Compliance with UL Standards and Canadian Standards (cUL certification) ()	14
G.4	Compliance with the Radio Waves Act (South Korea) ()	20

■ Safety precautions

Read this manual thoroughly before proceeding with installation, connections (wiring), operation, or maintenance and inspection. Ensure you have sound knowledge of the device and familiarize yourself with all safety information and precautions before proceeding to operate the inverter.

Safety precautions are classified into the following two categories in this manual.

 WARNING	Failure to heed the information indicated by this symbol may lead to dangerous conditions, possibly resulting in death or serious bodily injuries.
 CAUTION	Failure to heed the information indicated by this symbol may lead to dangerous conditions, possibly resulting in minor or light bodily injuries and/or substantial property damage.

Failure to heed the information contained under the CAUTION title can also result in serious consequences. These safety precautions are of utmost importance and must be observed at all times.

Application

 WARNING
<ul style="list-style-type: none"> The FRENIC-Ace is designed to drive a three-phase induction motor. Do not use it for single-phase motors or for other purposes. Fire or an accident could occur. The FRENIC-Ace may not be used for a life-support system or other purposes directly related to the human safety. Though the FRENIC-Ace is manufactured under strict quality control, install safety devices for applications where serious accidents or property damages are foreseen in relation to the failure of it. An accident could occur.

Installation

 WARNING
<ul style="list-style-type: none"> Install the inverter on a base made of metal or other non-flammable material. Otherwise, a fire could occur. Do not place flammable object nearby. Doing so could cause fire. Inverters FRN0085E2■-4G□ or above, whose protective structure is IP00, involve a possibility that a human body may touch the live conductors of the main circuit terminal block. Inverters to which an optional DC reactor is connected also involve the same. Install such inverters in an inaccessible place. Otherwise, electric shock or injuries could occur.

 CAUTION
<ul style="list-style-type: none"> Do not support the inverter by its front cover during transportation. Doing so could cause a drop of the inverter and injuries. Prevent lint, paper fibers, sawdust, dust, metallic chips, or other foreign materials from getting into the inverter or from accumulating on the heat sink. When changing the positions of the top and bottom mounting bases for external cooling, use only the specified screws. Otherwise, a fire or an accident might result. Do not install or operate an inverter that is damaged or lacking parts. Doing so could cause fire, an accident or injuries.

Wiring

WARNING

- If no zero-phase current (earth leakage current) detective device such as a ground-fault relay is installed in the upstream power supply line, in order to avoid the entire power supply system's shutdown undesirable to factory operation, install a residual-current-operated protective device (RCD)/earth leakage circuit breaker (ELCB) individually to inverters to break the individual inverter power supply lines only.

Otherwise, a fire could occur.

- When wiring the inverter to the power source, insert a recommended molded case circuit breaker (MCCB) or residual-current-operated protective device (RCD)/earth leakage circuit breaker (ELCB) (with overcurrent protection) in the path of each pair of power lines to inverters. Use the recommended devices within the recommended current capacity.
- Use wires in the specified size.
- Tighten terminals with specified torque.

Otherwise, a fire could occur.

- When there is more than one combination of an inverter and motor, do not use a multicore cable for the purpose of handling their wirings together.
- Do not connect a surge killer to the inverter's output (secondary) circuit.

Doing so could cause a fire.

- Be sure to connect an optional DC reactor (DCR) when the capacity of the power supply transformer exceeds 500 kVA and is 10 times or more the inverter rated capacity.

Otherwise, a fire could occur.

- Ground the inverter in compliance with the national or local electric code.
- Be sure to ground the inverter's grounding terminals .

Otherwise, an electric shock or a fire could occur.

- Qualified electricians should carry out wiring.
- Be sure to perform wiring after turning the power OFF.

Otherwise, an electric shock could occur.

- Be sure to perform wiring after installing the inverter unit.

Otherwise, an electric shock or injuries could occur.

- Ensure that the number of input phases and the rated voltage of the product match the number of phases and the voltage of the AC power supply to which the product is to be connected.

Otherwise, a fire or an accident could occur.

- Do not connect the power supply wires to output terminals (U, V, and W).
- When connecting a DC braking resistor (DBR), never connect it to terminals other than terminals P(+) and DB.

Doing so could cause fire or an accident.

- In general, sheaths of the control signal wires are not specifically designed to withstand a high voltage (i.e., reinforced insulation is not applied). Therefore, if a control signal wire comes into direct contact with a live conductor of the main circuit, the insulation of the sheath might break down, which would expose the signal wire to a high voltage of the main circuit. Make sure that the control signal wires will not come into contact with live conductors of the main circuit.

Doing so could cause an accident or an electric shock.

WARNING

- Before changing the switches or touching the control circuit terminal symbol plate, **turn OFF the power and wait at least five minutes for inverters FRN0115E2■-2□ / FRN0072E2■-4□ / FRN0011E2■-7□ or below, or at least ten minutes for inverters FRN0085E2■-4□ or above.** Make sure that the LED monitor and charging lamp are turned OFF. Further, make sure, using a multimeter or a similar instrument, that the DC link bus voltage between the terminals P(+) and N(-) has dropped to the safe level (+25 VDC or below).

Otherwise, an electric shock could occur.

CAUTION

- The inverter, motor and wiring generate electric noise. Be careful about malfunction of the nearby sensors and devices. To prevent them from malfunctioning, implement noise control measures.

Otherwise an accident could occur.

WARNING

- Be sure to mount the front cover before turning the power ON. Do not remove the cover when the inverter power is ON.

Otherwise, an electric shock could occur.

- Do not operate switches with wet hands.



Doing so could cause electric shock.

- If the auto-reset function has been selected, the inverter may automatically restart and drive the motor depending on the cause of tripping. Design the machinery or equipment so that human safety is ensured at the time of restarting.

Otherwise, an accident could occur.

- If the stall prevention function (current limiter), automatic deceleration (anti-regenerative control), or overload prevention control has been selected, the inverter may operate with acceleration/deceleration or frequency different from the commanded ones. Design the machine so that safety is ensured even in such cases.

- The  key on the keypad is effective only when the keypad operation is enabled with function code F02 (= 0, 2 or 3). When the keypad operation is disabled, prepare an emergency stop switch separately for safe operations.

Switching the run command source from keypad (local) to external equipment (remote) by turning ON the "Enable communications link" command **LE** disables the  key. To enable the  key for an emergency stop, select the STOP key priority with function code H96 (= 1 or 3).

- If any of the protective functions have been activated, first remove the cause. Then, after checking that the all run commands are set to OFF, release the alarm. If the alarm is released while any run commands are set to ON, the inverter may supply the power to the motor, running the motor.

Otherwise, an accident could occur.

- If you enable the "Restart mode after momentary power failure" (Function code F14 = 3 to 5), then the inverter automatically restarts running the motor when the power is recovered.

Design the machinery or equipment so that human safety is ensured after restarting.

- If the user configures the function codes wrongly without completely understanding the User's Manual, the motor may rotate with a torque or at a speed not permitted for the machine.

- Starting auto-tuning involves motor rotation. Sufficiently check that motor rotation brings no danger beforehand.

An accident or injuries could occur.

- Even if the inverter has interrupted power to the motor, if the voltage is applied to the main circuit input terminals L1/R, L2/S, L3/T, L1/L and L2/N, voltage may be output to inverter output terminals U, V, and W.

- Even if the motor is stopped due to DC braking or preliminary excitation, voltage is output to inverter output terminals U, V, and W.

An electric shock may occur.

- The inverter can easily accept high-speed operation. When changing the speed setting, carefully check the specifications of motors or equipment beforehand.

Otherwise, injuries could occur.

CAUTION

- Do not touch the heat sink and braking resistor because they become very hot.

Doing so could cause burns.

- The DC brake function of the inverter does not provide any holding mechanism.

Injuries could occur.

- Ensure safety before modifying the function code settings. Run commands (e.g., "Run forward" **FWD**), stop commands (e.g., "Coast to a stop" **BX**), and frequency change commands can be assigned to digital input terminals. Depending upon the assignment states of those terminals, modifying the function code setting may cause a sudden motor start or an abrupt change in speed.
- When the inverter is controlled with the digital input signals, switching run or frequency command sources with the related terminal commands (e.g., **SS1**, **SS2**, **SS4**, **SS8**, **Hz2/Hz1**, **Hz/PID**, **IVS**, and **LE**) may cause a sudden motor start or an abrupt change in speed.
- Ensure safety before modifying customizable logic related function code settings (U codes and related function codes) or turning ON the "Cancel customizable logic" terminal command **CLC**. Depending upon the settings, such modification or cancellation of the customizable logic may change the operation sequence to cause a sudden motor start or an unexpected motor operation.

An accident or injuries could occur.

Maintenance and inspection, and parts replacement

WARNING

- Before proceeding to the maintenance/inspection jobs, **turn OFF the power and wait at least five minutes for inverters FRN0115E2-2□ / FRN0072E2-4□ / FRN0011E2-7□ or below, or at least ten minutes for inverters FRN0085E2-4□ or above.** Make sure that the LED monitor and charging lamp are turned OFF. Further, make sure, using a multimeter or a similar instrument, that the DC link bus voltage between the terminals P(+) and N(-) has dropped to the safe level (+25 VDC or below).

Otherwise, an electric shock could occur.

- Always carry out the daily and periodic inspections described in the instruction/user's manual. Use of the inverter for long periods of time without carrying out regular inspections could result in malfunction or damage, and an accident or fire could occur.
- It is recommended that periodic inspections be carryout every one to two years, however, they should be carried out more frequently depending on the usage conditions.
- It is recommended that parts for periodic replacement be replaced in accordance with the standard replacement frequency indicated in the user's manual. Use of the product for long periods of time without replacement could result in malfunction or damage, and an accident or fire could occur.
- Contact outputs [30A/B/C] use relays, and may remain ON, OFF, or undetermined when their lifetime is reached. In the interests of safety, equip the inverter with an external protective function.

Otherwise, an accident or fire could occur.

- Maintenance, inspection, and parts replacement should be made only by qualified persons.
- Take off the watch, rings and other metallic objects before starting work.
- Use insulated tools.

Otherwise, an electric shock or injuries could occur.

- Never modify the inverter.

Doing so could cause an electric shock or injuries.

Disposal

CAUTION

- Treat the inverter as an industrial waste when disposing of it.

Otherwise injuries could occur.

FREE OF CHARGE WARRANTY PERIOD AND WARRANTY RANGE

Free of charge warranty period

- (1) The product warranty period is “1 year from the date of purchase” or 24 months from the manufacturing date imprinted on the name place, whichever date is earlier.
- (2) However, in cases where the use environment, conditions of use, use frequency and times used, etc., have an effect on product life, this warranty period may not apply.
- (3) Furthermore, the warranty period for parts restored by Fuji Electric’s Service Department is “6 months from the date that repairs are completed.”

Warranty range

- (1) In the event that breakdown occurs during the product’s warranty period which is the responsibility of Fuji Electric, Fuji Electric will replace or repair the part of the product that has broken down free of charge at the place where the product was purchased or where it was delivered. However, if the following cases are applicable, the terms of this warranty may not apply.
 - The breakdown was caused by inappropriate conditions, environment, handling or use methods, etc. which are not specified in the catalog, operation manual, specifications or other relevant documents.
 - The breakdown was caused by the product other than the purchased or delivered Fuji’s product.
 - The breakdown was caused by the product other than Fuji’s product, such as the customer’s equipment or software design, etc.
 - Concerning the Fuji’s programmable products, the breakdown was caused by a program other than a program supplied by this company, or the results from using such a program.
 - The breakdown was caused by disassembly, modifications or repairs affected by a party other than Fuji Electric.
 - The breakdown was caused by improper maintenance or replacement using consumables, etc. specified in the operation manual or catalog, etc.
 - The breakdown was caused by a science or technical problem that was not foreseen when making practical application of the product at the time it was purchased or delivered.
 - The product was not used in the manner the product was originally intended to be used.
 - The breakdown was caused by a reason which is not this company’s responsibility, such as lightning or other disaster.
- (2) Furthermore, the warranty specified herein shall be limited to the purchased or delivered product alone.
- (3) The upper limit for the warranty range shall be as specified in item (1) above and any damages (damage to or loss of machinery or equipment, or lost profits from the same, etc.) consequent to or resulting from breakdown of the purchased or delivered product shall be excluded from coverage by this warranty.

GENERAL PRECAUTIONS

Drawings in this manual may be illustrated without covers or safety shields for explanation of detail parts. Restore the covers and shields in the original state and observe the description in the manual before starting operation.

Icons

The following icons are used throughout this manual.



This icon indicates information which, if not heeded, can result in the inverter not operating to full efficiency, as well as information concerning incorrect operations and settings which can result in accidents.



This icon indicates information that can be useful when performing certain settings or operations.



This icon indicates a reference to more detailed information.

Chapter 1 BEFORE USE

1.1 Acceptance Inspection (Nameplates and Inverter Type)

Unpack the package and check the following:

- (1) An inverter and the following accessories are contained in the package.
 - Accessories - DC reactor (for ND-mode inverters of FRN0139E2-4G□ or above, HD/HND-mode inverters of FRN0168E2-4G□ or above, and HHD-mode inverters of FRN0203E2-4G□ or above) (Not included with the FRN****E2-4C(china model))
 - Keypad rear cover (with three screws for securing the keypad)
 - Instruction manual
 - CD-ROM (containing the FRENIC-Ace User's Manual)
- (2) The inverter has not been damaged during transportation—there should be no dents or parts missing.
- (3) The inverter is the type you ordered. You can check the type and specifications on the main nameplate. (The main and sub nameplates are attached to the inverter as shown on Figure 1.2-1.)

Fuji Electric		MSIP-REI-fek-ACE	UL LISTED	7556 NO. CONT. 60
TYPE	FRN0012E2S-4GA			
	ND	HD	HND	HHD
SOURCE	3PH 380-480V 50/60Hz / 1PH 380-480V 50/60Hz			
	13A	13A	13A	9.0A
OUTPUT	3PH 380-480V			
	0.1-120Hz	0.1-500Hz	0.1-500Hz	0.1-500Hz
Source of 3PH	12A	11.1A	11.1A	9.0A
Source of 1PH	-	-	-	5.6A
601 IP Code IP20	SCCR 100kA	MASS	kg	Designed by Fuji Electric, Japan
SER.No. T31A123A0579AA		WEIGHT	lbs	Assembled in Thailand TH

TYPE	FRN0012E2S-4GA
SER.No.	T31A123A0579AA

(a) Main Nameplate

(b) Sub Nameplate

Figure 1.1-1 Nameplates

TYPE: Type of inverter

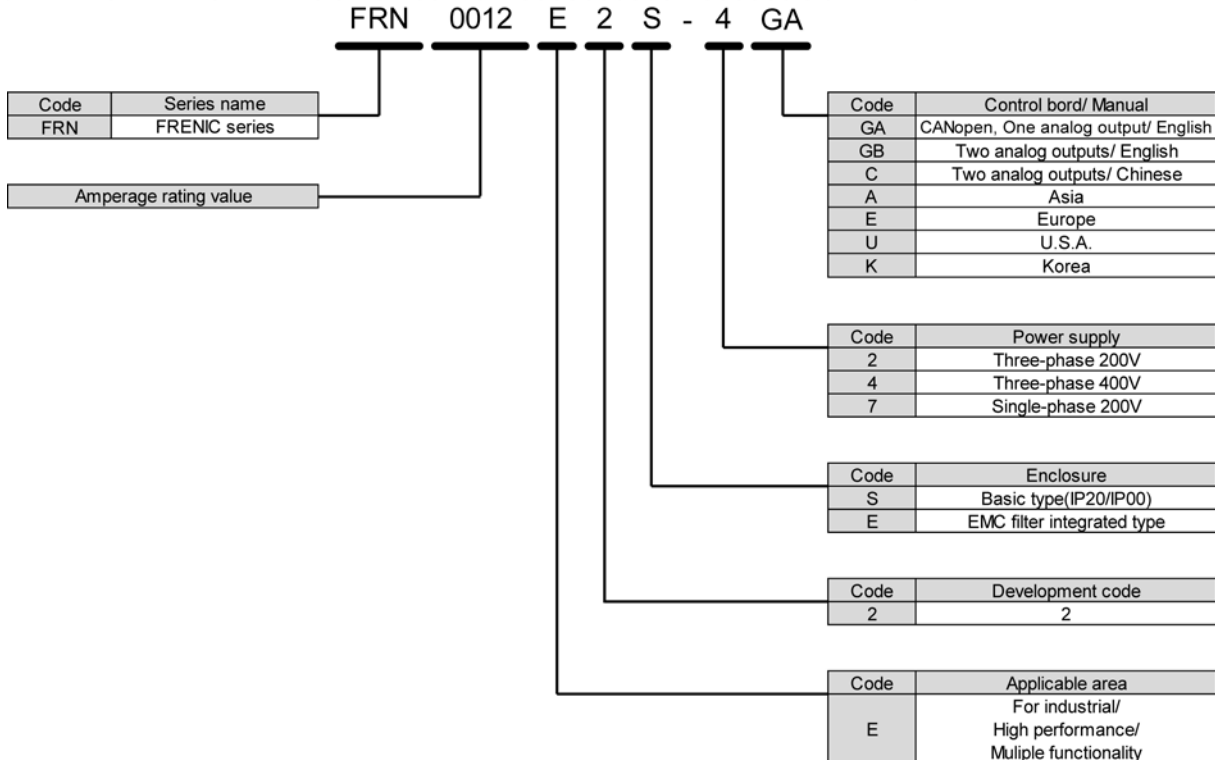

Figure 1.1-2 Type of inverter

1.1 Acceptance Inspection (Nameplates and Inverter Type)

The FRENIC-Ace is available in four different drive modes--ND (Normal Duty), HD (Heavy Duty), HND (High, Normal Duty), and HHD (High, Heavy Duty). One of these modes should be selected to match the load property of your system. Specifications in each mode are printed on the main nameplate.

- ND mode : Designed for general load applications.
Overload capability: 120% for 1 min.
- HD mode : Designed for heavy duty load applications.
Overload capability: 150% for 1 min.
- HND mode : Designed for general load applications.
Overload capability: 120% for 1 min.
- HHD mode : Designed for heavy duty load applications.
Overload capability: 150% for 1 min. and 200% for 0.5 s.
- SOURCE : Number of input phases (three-phase: 3PH), input voltage, input frequency, input current
- OUTPUT : Number of output phases, rated output voltage, output frequency range, rated output capacity, rated output current, and overload capability
- SCCR : Short-circuit capacity
- MASS : Mass of the inverter in kilogram
- SER. No. : Product number

6 8 A 1 2 3 A 0 5 7 9 E BB 6 0 1

Production week
This indicates the week number that is numbered from 1st week of January.
The 1st week of January is indicated as '01'.
Production year: Last digit of year
Product version



: Compliance with European Standards (See Appendix G Section G-1)



: Compliance with UL Standards and Canadian Standards (cUL certification)
(See Appendix G Section G-2)



: Compliance with the Radio Waves Act (South Korea) (See Appendix G Section G-3)



: Compliance with Russian Standards

If you suspect the product is not working properly or if you have any questions about your product, contact your Fuji Electric representative.

1.2 External View and Terminal Blocks

(1) Outside and inside views

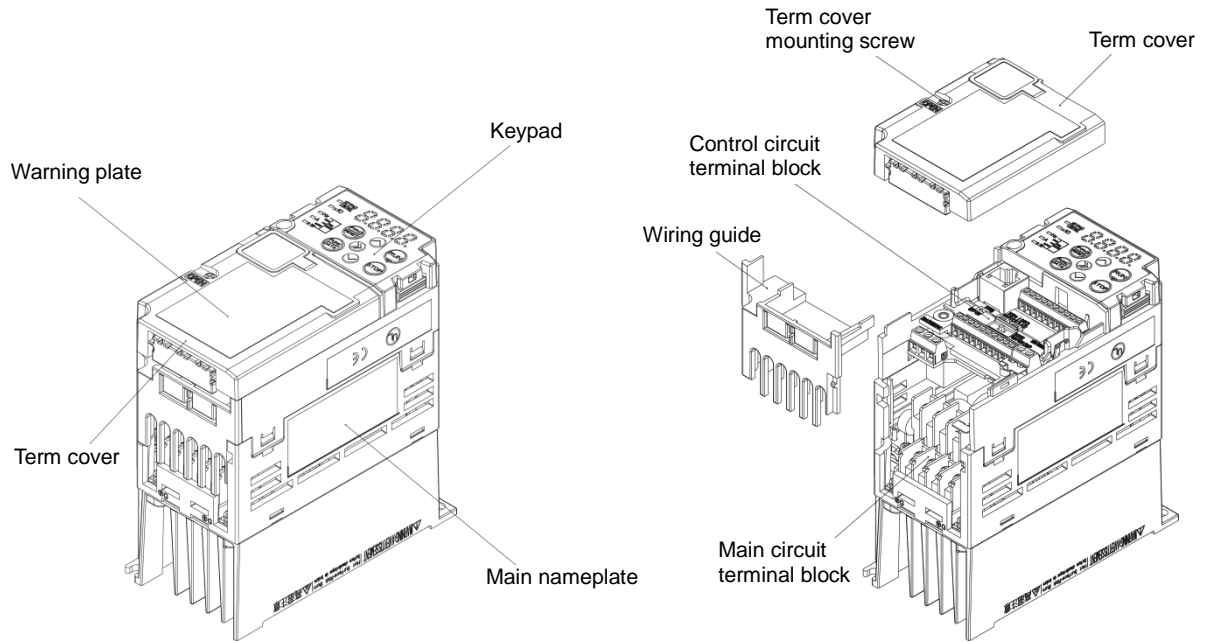

(a) FRN0006E2S-2□

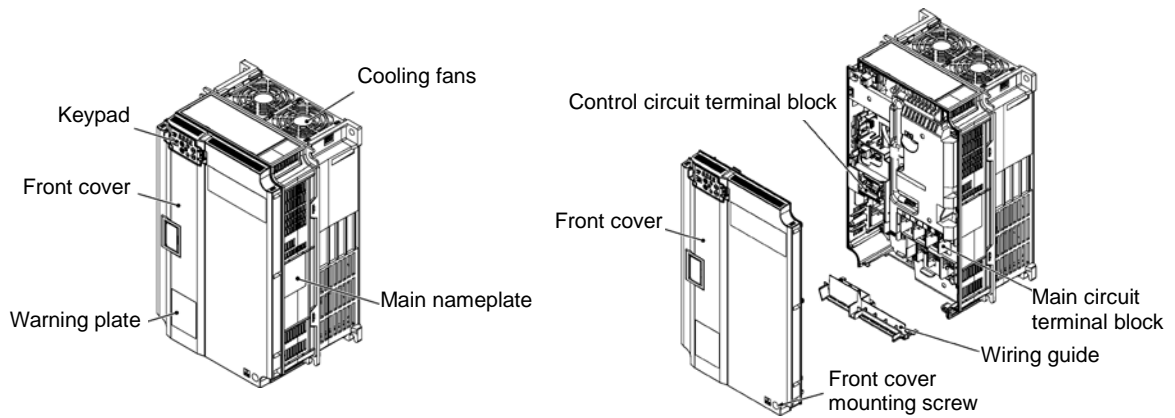

(b) FRN0072E2S-4□

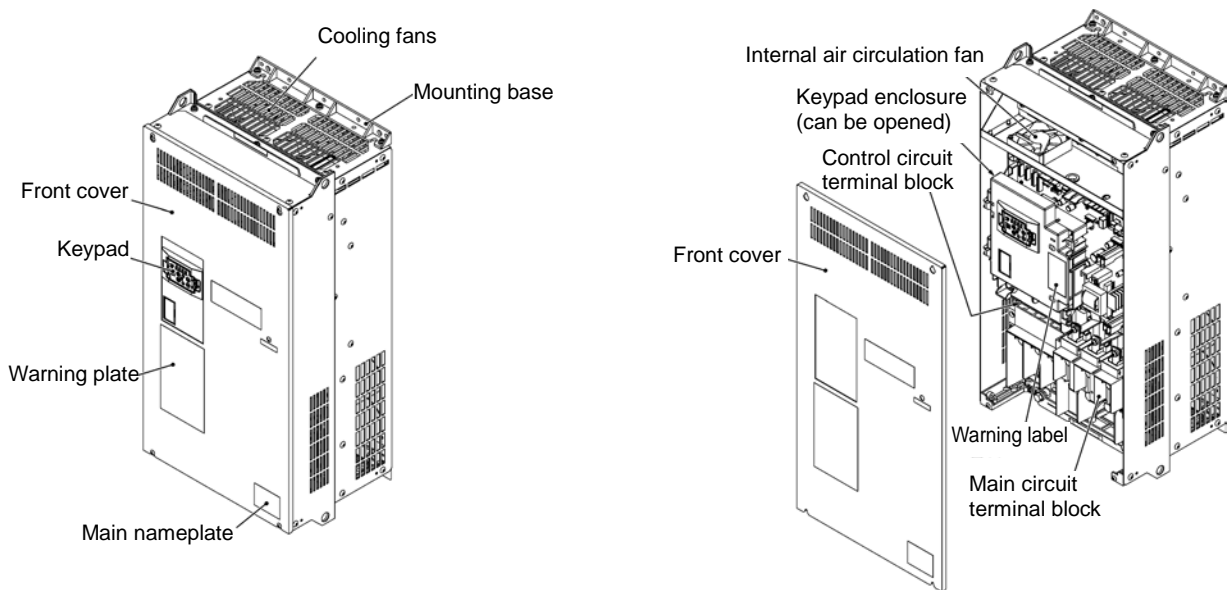

(c) FRN0590E2S-4□

Figure 1.2-1 Outside and Inside Views of Inverters

(2) Warning plates and label

 WARNING 
<p>■ RISK OF INJURY OR ELECTRIC SHOCK</p> <ul style="list-style-type: none"> Refer to the instruction manual before installation and operation. Do not remove any cover while applying power and at least 5min. after disconnecting power. Securely ground (earth) the equipment. High touch current.
 AVERTISSEMENT
<p>■ RISQUE DE BLESSURE OU DE CHOC ÉLECTRIQUE</p> <p>Ne retirez pas le couvercle lorsque vous mettez sous tension.</p> <ul style="list-style-type: none"> Ce couvercle peut être retiré au moins 5 minutes après la mise hors tension et quand le témoin «ACTIF» s'éteint. Plus d'un circuit électrique actif. Reportez-vous au manuel d'instruction.
 警告
<p>■ けが、感電のおそれあり</p> <ul style="list-style-type: none"> 取付け、運転の前に必ず取扱説明書を読んでその指示に従うこと。 通電中および電源しゃ断後5分以内は表面カバーを開けないこと。 確実に接地をおこなうこと。
<p>Only type B of RCD is allowed. See manual for details.</p>

(a) FRN0006E2■-4G□

 WARNING 
<p>■ RISK OF INJURY OR ELECTRIC SHOCK</p> <ul style="list-style-type: none"> Refer to the instruction manual before installation and operation. Do not remove this cover while applying power. This cover can be removed after at least 10 min of power off and after the "CHARGE" lamp turns off. More than one live circuit. See instruction manual. Do not insert fingers or anything else into the inverter. Securely ground (earth) the equipment. High touch current.
 警告
<p>■ 有可能引起受伤、触电</p> <ul style="list-style-type: none"> 安装运行之前请务必阅读操作说明书并遵照其指示 通电中不要打开表面盖板 断电10分钟以上、充电指示灯熄灭后方可打开表面盖板 打开表面盖时, 要确认已经切断各路的辅助电源 (请参考说明书) 即使在安装了表面盖板时, 也不要从缝隙间插入手指或其他异物 请正确接地
 警告
<p>■ けが、感電のおそれあり</p> <ul style="list-style-type: none"> 取付け準備の際に、必ず取扱説明書を読んでその指示に従うこと。 通電中は、表面カバーを開けないこと。 表面カバーを開ける場合は、電源しゃ断後10分以上経過後チャージランプが消灯したのを確認してから行うこと。 表面カバーを開ける場合は、各種助電源もしゃ断していることを確認してから行うこと (取扱説明書を参照のこと)。 表面カバー取付状態であっても、開口部より装置内部に指や物等挿入しないこと。 確実に接地をおこなうこと。
<p>Only type B of RCD is allowed. See manual for details.</p>

(b) FRN0203E2■-4G□

 AVERTISSEMENT
<p>■ RISQUE DE BLESSURE OU DE CHOC ÉLECTRIQUE</p> <ul style="list-style-type: none"> Ne retirez pas le couvercle lorsque vous mettez sous tension. Ne pas ouvrir cette couvercle pendant 10 minutes après avoir coupé l'alimentation ou lors de la mise sous tension. Plus d'un circuit électrique actif. Reportez-vous au manuel d'instruction.

Figure 1.2-2 Warning Plates and Label

1.3 Precautions for Using Inverters

Fuji Electric strongly recommends installing inverters in a panel for safety reasons, in particular, when installing the ones whose enclosure rating is IP00.

When installing the inverter in a place out of the specified environmental requirements, it is necessary to derate the inverter or consider the panel engineering design suitable for the special environment or the panel installation location. For details, refer to the Fuji Electric technical information "Engineering Design of Panels" or consult your Fuji Electric representative.

The special environments listed below require using the specially designed panel or considering the panel installation location.

Environments	Possible problems	Sample measures	Applications
Highly concentrated sulfidizing gas or other corrosive gases	Corrosive gases cause parts inside the inverter to corrode, resulting in an inverter malfunction.	Any of the following measures may be necessary. <ul style="list-style-type: none"> - Mount the inverter in a sealed panel with IP6X or air-purge mechanism. - Place the panel in a room free from influence of the gases. 	Paper manufacturing, sewage disposal, sludge treatment, tire manufacturing, gypsum manufacturing, metal processing, and a particular process in textile factories.
A lot of conductive dust or foreign material (e.g., metal powders or shavings, carbon fibers, or carbon dust)	Entry of conductive dust into the inverter causes a short circuit.	Any of the following measures may be necessary. <ul style="list-style-type: none"> - Mount the inverter in a sealed panel. - Place the panel in a room free from influence of the conductive dust. 	Wiredrawing machines, metal processing, extruding machines, printing presses, combustors, and industrial waste treatment.
A lot of fibrous or paper dust	Fibrous or paper dust accumulated on the heat sink lowers the cooling effect. Entry of dust into the inverter causes the electronic circuitry to malfunction.	Any of the following measures may be necessary. <ul style="list-style-type: none"> - Mount the inverter in a sealed panel that shuts out dust. - Ensure a maintenance space for periodical cleaning of the heat sink in panel engineering design. - Employ external cooling when mounting the inverter in a panel for easy maintenance and perform periodical maintenance. 	Textile manufacturing and paper manufacturing.
High humidity or dew condensation	In an environment where a humidifier is used or where the air conditioner is not equipped with a dehumidifier, high humidity or dew condensation results, which causes a short-circuiting or malfunction of electronic circuitry inside the inverter.	<ul style="list-style-type: none"> - Put a heating module such as a space heater in the panel. 	Outdoor installation. Film manufacturing line, pumps and food processing.
Vibration or shock exceeding the specified level	If a large vibration or shock exceeding the specified level is applied to the inverter, for example, due to a carrier running on seam joints of rails or blasting at a construction site, the inverter structure gets damaged.	<ul style="list-style-type: none"> - Insert shock-absorbing materials between the mounting base of the inverter and the panel for safe mounting. 	Installation of an inverter panel on a carrier or self-propelled machine. Ventilating fan at a construction site or a press machine.
Fumigation for export packaging	Halogen compounds such as methyl bromide used in fumigation corrodes some parts inside the inverter.	<ul style="list-style-type: none"> - When exporting an inverter built in a panel or equipment, pack them in a previously fumigated wooden crate. - When packing an inverter alone for export, use a laminated veneer lumber (LVL). 	Exporting.

1.3.2 Storage environment

The storage environment in which the inverter should be stored after purchase differs from the usage environment. Store the inverter in an environment that satisfies the requirements listed below.

[1] Temporary storage

Table 1.3-3 Storage and Transport Environments

Item	Specifications	
Storage temperature *1	During transport: -25 to +70°C (-13 to +158°F)	Places not subjected to abrupt temperature changes or condensation or freezing
	During storage: -25 to +65°C (-13 to +153°F)	
Relative humidity	5 to 95% RH *2	
Atmosphere	The inverter must not be exposed to dust, direct sunlight, corrosive or flammable gases, oil mist, vapor, water drops or vibration. The atmosphere must contain only a low level of salt. (0.01 mg/cm ² or less per year)	
Atmospheric pressure	86 to 106 kPa (during storage)	
	70 to 106 kPa (during transportation)	

*1 Assuming comparatively short time storage, e.g., during transportation or the like.

*2 Even if the humidity is within the specified requirements, avoid such places where the inverter will be subjected to sudden changes in temperature that will cause condensation or freezing.

Precautions for temporary storage

- (1) Do not leave the inverter directly on the floor.
- (2) If the environment does not satisfy the specified requirements listed in Table 1.3-3, wrap the inverter in an airtight vinyl sheet or the like for storage.
- (3) If the inverter is to be stored in a high-humidity environment, put a drying agent (such as silica gel) in the airtight package described in (2) above.

[2] Long-term storage

The long-term storage method of the inverter varies largely according to the environment of the storage site. General storage methods are described below.

- (1) The storage site must satisfy the requirements specified for temporary storage.
However, for storage exceeding three months, the surrounding temperature range should be within the range from -10 to +30°C (14 to 86°F). This is to prevent electrolytic capacitors in the inverter from deterioration.
- (2) The package must be airtight to protect the inverter from moisture. Add a drying agent inside the package to maintain the relative humidity inside the package within 70%.
- (3) If the inverter has been installed to the equipment or panel at construction sites where it may be subjected to humidity, dust or dirt, then temporarily remove the inverter and store it in the environment specified in Table 1.3-3.

Precautions for storage over 1 year

If the inverter has not been powered on for a long time, the property of the electrolytic capacitors may deteriorate. Power the inverters on once a year and keep the inverters powering on for 30 to 60 minutes. Do not connect the inverters to the load circuit (secondary side) or run the inverter.

Chapter 2 INSTALLATION AND WIRING

2.1 Installation

(1) Installation Environment

Please install FRENIC-Ace in locations which meet the conditions specified in Chapter 1 "1.3.1 Usage environment".

(2) Installation Surface

Please install the inverter on non-combustible matter such as metals. Also, do not mount it upside down or horizontally.

⚠ WARNING

Install on non-combustible matter such as metals.

Risk of fire exists

(3) Surrounding Space

Secure the space shown in Figure 2.1-1 and Table 2.1-1. When enclosing FRENIC-Ace in cabinets, be sure to provide adequate ventilation to the cabinet, as the surrounding temperature may rise. Do not contain it in small enclosures with low heat dissipation capacity.

■ Installation of Multiple Inverters

When installing 2 or more units in the same equipment or cabinet, generally mount them to the side of each other, not above each other. When the inverters are mounted above each other, attach partitioning boards to prevent that the heat dissipated from the lower inverter affects the upper inverter.

For types FRN0072E2■-4□, FRN0115E2■-2□, FRN0011E2■-7□ or below and for ambient temperature below 40°C only, the units can be installed side by side without any spacing between them. (30°C or lower for ND and HD)

Table 2.1-1 Surrounding Space mm (inch)

Applicable Capacity	A	B	C
200 V class: FRN0001 to 0115E2■-2□	10	100 (3.9)	0 ^{*1}
200 V class: FRN0001 to 0011E2■-7□ 400 V class: FRN0002 to 0072E2■-4□	(0.39)		
400 V class: FRN0085 to 0590E2■-4□	50 (1.97)		100 (3.9)

*1 A clearance of 50 mm is required to use RJ45 connector.

C: Space in front of the inverter unit

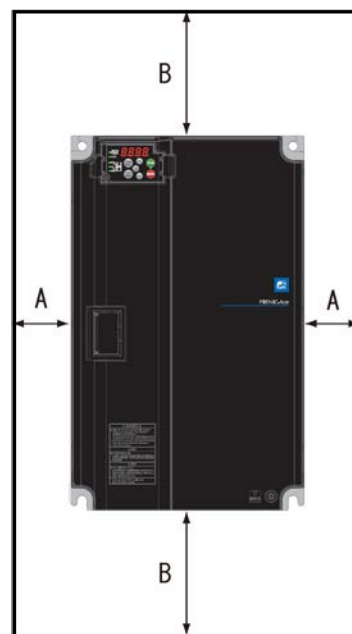

Figure 2.1-1 Installation Direction

■ Installation with External Cooling

The external cooling installation reduces the generated heat inside the panel by dissipating approximately 70% of the total heat generated (total heat loss) by mounting the cooling fins protruding outside the equipment or cabinet.

Installation with external cooling is possible for types FRN0030 to 0115E2■-2□ and FRN0022 to 0072E2■-4□ by adding attachments (optional) for external cooling, and for types FRN0085E2■-4□ or above by moving the mounting bases.

(Please refer to the FRENIC-Ace User's Manual, Chapter 11 Item 11.15 for the external dimensions drawing of the external cooling attachment (optional)).

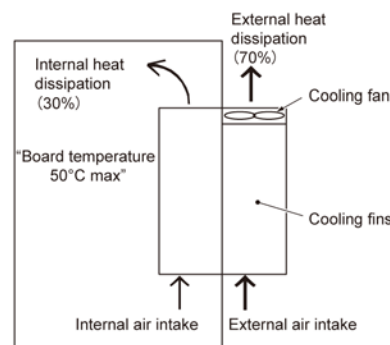

Figure 2.1-2 Installation with External Cooling

⚠ CAUTION

Prevent lint, wastepaper, wood shavings, dust, metal scrap, and other foreign material from entering the inverter or from attaching to the cooling fins.

Risk of fire and risk of accidents exist

To install the FRN0085E2-4□ inverter with external cooling, change the mounting position of the mounting bases following the procedure in Figure 2.1-3.

As the type and number of screws differ by inverter type, please review Table 2.1-2.

Table 2.1-2 Type and Number of Screws, and Tightening Torque

Inverter type	Mounting base fixation screw	Case attachment screw	Tightening torque N·m (lb-in)
FRN0085E2-4□ to FRN0168E2-4□	M6×20 (5 screws on top, 3 screws on bottom)	M6×20 (2 screws on top only)	5.8 (51.3)
FRN0203E2-4□	M6×20 (3 screws on top and bottom each)	M6×12 (3 screws on top only)	5.8 (51.3)
FRN0240E2-4□ to FRN0290E2-4□	M5×12 (7 screws on top and bottom each)	M5×12 (7 screws on top only)	3.5 (31.0)
FRN0361E2-4□ to FRN0415E2-4□	M5×16 (7 screws on top and bottom each)	M5×16 (7 screws on top only)	3.5 (31.0)
FRN0520E2-4□ to FRN0590E2-4□	M5×16 (8 screws on top and bottom each)	M5×16 (8 screws on top only)	3.5 (31.0)

- 1) Remove all of the mounting base fixation screws and the case attachment screws on the top of the inverter.
- 2) Fix the mounting bases to the case attachment screw holes using the mounting base fixation screws. A few screws should remain after changing the position of the mounting bases.
- 3) Change the position of the mounting bases on the bottom side following the procedure in 1) and 2).

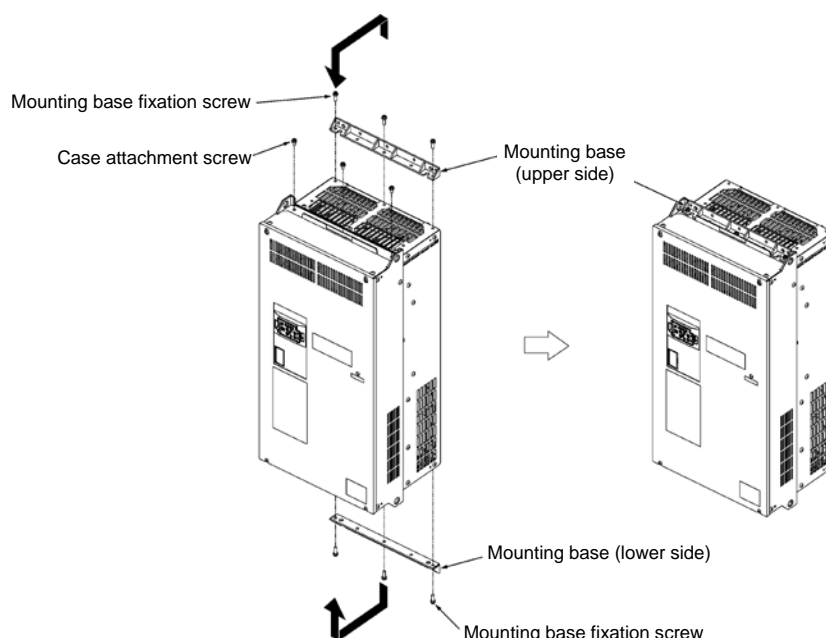

Figure 2.1-3 Method to Change the Mounting Base Positions

⚠ CAUTION

Use the specified screws in changing the mounting bases.

Risk of fire and risk of accidents exist

■ Inverter unit installation screw size

Select the bolt size, considering the thickness of the mounting feet and installation surface so that the bolt protrudes from the nut by 2 threads or more.

Inverter type	Inverter fixation screw	Tightening torque N·m (lb-in)
200V class : FRN0030/0040E2-2□ 400V class : FRN0022/0029E2-4□	M5 (4 screws)	3.5 (31.0)
200V class : FRN0056/0069E2-2□ 400V class : FRN0037E2-4□ to FRN0203E2-4□	M8 (4 screws)	13.5 (119)
400V class : FRN0240E2-4□ to FRN0415E2-4□	M12 (4 screws)	48 (425)
400V class : FRN0520E2-4□ to FRN0590E2-4□	M12 (6 screws)	48 (425)

2.2 Wiring

2.2.1 Basic connection diagram

■ Model-GA-A/E-U-K, Standard terminal block board (with CAN)

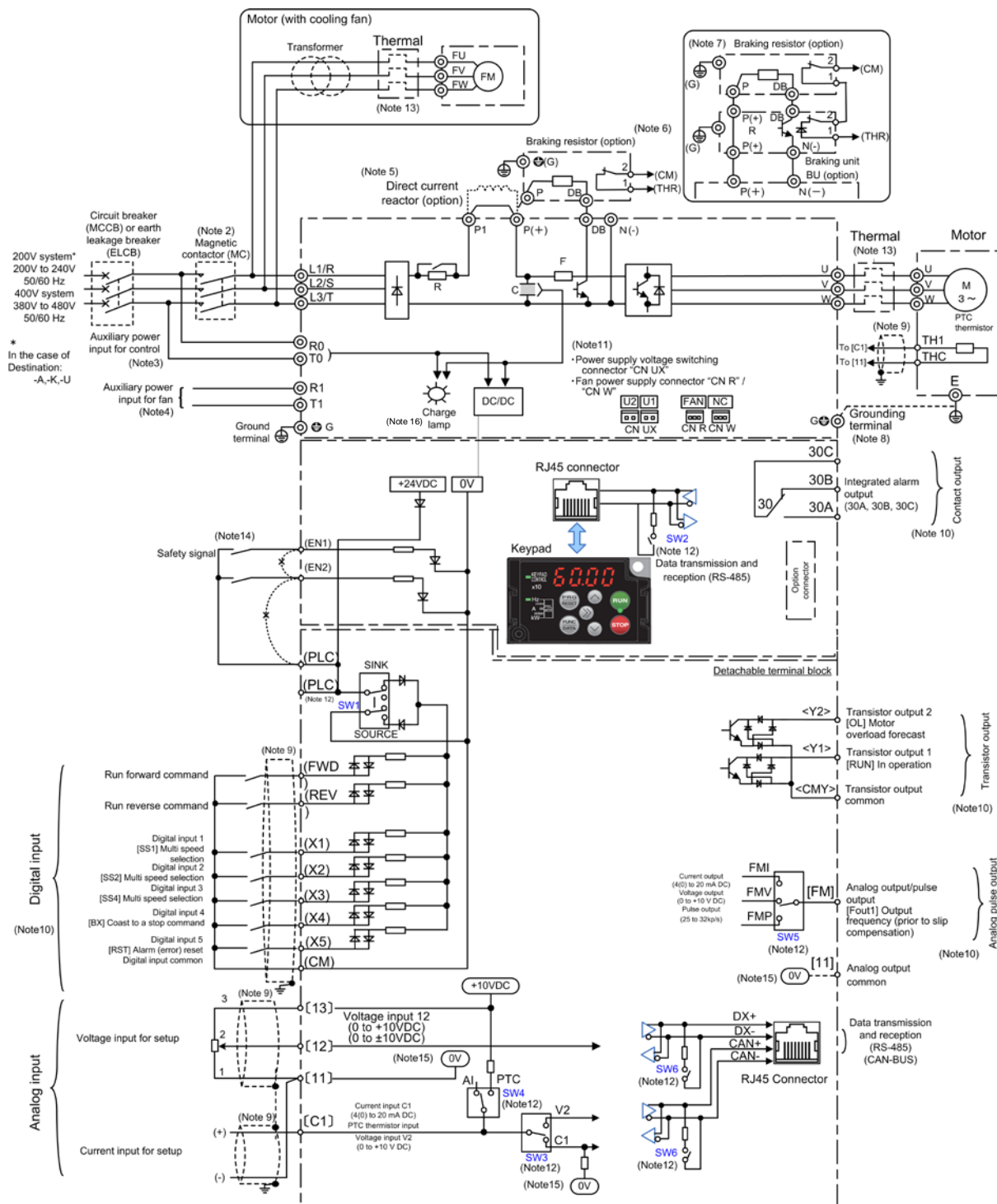

Figure 2.2-1 Standard Terminal Block Board (with CAN)

■ Model-GB/ Model-C, Standard terminal block board (without CAN, with FM2)

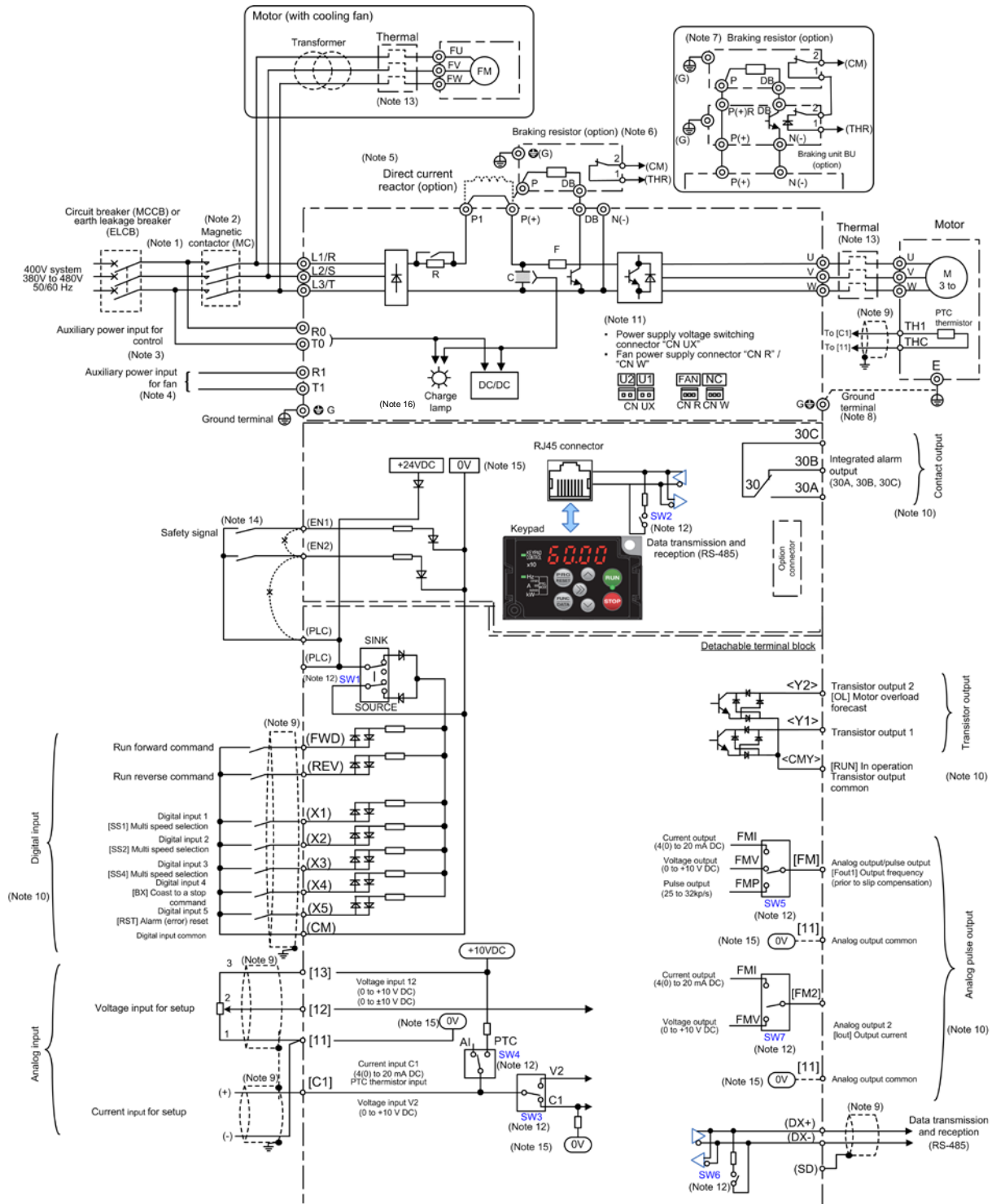

Figure 2.2-2 Standard Terminal Block Board (Without CAN, With FM2)

- (Note 1) Install recommended circuit breakers (MCCB) or residual-current-operated protective device (RCD)/ earth leakage breakers (ELCB) (with overcurrent protective function) on the inputs of each inverter (primary side) for wiring protection. Do not use breakers which exceed the recommended rated current.
- (Note 2) Install recommended magnetic contactors (MC) as necessary on each inverter as these will be used to disconnect the inverter from the power supply separately from the MCCB or RCD / the ELCB. Additionally, when installing coils such as MC or solenoid close to the inverter, connect surge absorbers in parallel.
- (Note 3) When it is desired to retain the alarm signal for the activation of the protective function even inverter main power supply is shut off, or when it is desired continuous display of the keypad, connect this terminal to the power supply. The inverter can be operated without connecting power to this terminal (applicable for types FRN0059E2■-4□/ FRN00088E2■-2□ or above)
- (Note 4) The terminal does not need to be connected. Use this terminal when operating in combination with a high power factor regenerative PWM converter (RHC series). Applicable for types FRN0203E2■-4□ or above)
- (Note 5) Remove the shorting bar between the inverter main circuit terminals P1-P(+) before connecting the direct current reactor (DCR) (option).
It must be connected in the following cases:
ND mode: Types FRN0139 E2■-4□ or above, HD/ HND mode: Types FRN0168E2■-4□ or above, HHD mode: Types FRN0203E2■-4□ or above.
Use the direct current reactor (option) when the power supply transformer capacity is above 500 kVA and the transformer capacity is over 10 times the rated capacity of the inverter, or when “thyristor load exists” in the same power system.
- (Note 6) Types FRN0011E2■-7□/FRN0115E2■-2□/ FRN0072E2■-4□ or below have built-in braking transistors, allowing direct connection of braking resistors between P(+)-DB.
- (Note 7) When connecting braking resistors to types FRN0085E2■-4□ or above, always add the braking unit (option). Connect the braking unit (option) between P(+)-N(-). Auxiliary terminals [1] and [2] have polarity. Please connect as shown in the diagram.
- (Note 8) This terminal is used for grounding the motor. Grounding the motor using this terminal is recommended in order to suppress inverter noise.
- (Note 9) Use twisted lines or shielded lines for the control signals.
Generally, the shielded line requires grounding, but when the effect of externally induced noise is large, connecting to [CM] may suppress the effect of noise. Separate the line from the main circuit wiring and do not enclose in the same duct. (Separation distance of over 10 cm is recommended.) When crossing the main circuit wiring, make the intersection perpendicular.
- (Note 10) The various functions listed for terminals[X1] to [X5](digital inputs), terminals [Y1] to [Y2](transistor output), and terminal [FM] (monitor output) show the functions assigned as factory default.
- (Note 11) These are connectors for switching the main circuit. For details, refer to “2.2.7 Switching connector (types FRN0203E2■-4□ or above)”.
- (Note 12) The slide switches on the control printed circuit board define the settings for the inverter operation. For details, refer to “2.2.8 Operating slide switches”.
- (Note 13) Make the circuit breakers (MCCB) or the magnetic contactors (MC) trip by the thermal relay auxiliary contacts (manual recovery).
- (Note 14) Shorting bars are connected between the safety function terminals [EN1], [EN2], and [PLC] as factory default. Remove the shorting bars when using this function.
- (Note 15) $\square 0V$ and $\bigcirc 0V$ are separated and insulated.
- (Note 16) Charge lamp does not exist in the inverters FRN0069E2■-2□/FRN0044E2■-4□/FRN0011E2■-7□ or below.

Route the wiring following the steps below. The descriptions assume that the inverter is already fixed to the cabinet.

2.2.2 Removal and attachment of the front cover/ terminal cover and wiring guide

⚠ CAUTION

Always remove the RS-485 communication cable from the RJ-45 connector before removing the front cover.

Risk of fire and risk of accidents exist.

(1) Types FRN0020E2-2□/ FRN0012E2-4□/ FRN0011E2-7□ or below

- 1) Loosen the screws of the terminal cover. To remove the terminal cover, put your finger in the dimple of the terminal cover and then pull it up toward you.
- 2) Pull out the wiring guide toward you.
- 3) After routing the wires, attach the wiring guide and the terminal cover reversing the steps above.

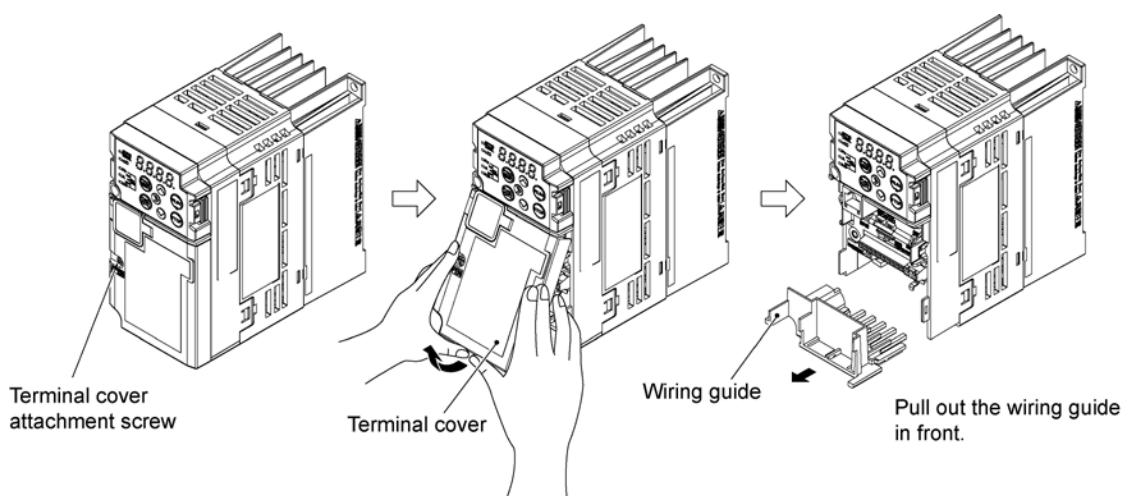

Figure 2.2-3 Removal of the Terminal Cover and the Wiring Guide (for FRN0006E2S-2□)

(2) Types FRN0030E2-2□ to FRN0069E2-2□ and FRN0022E2-4□ to FRN0044 E2-4□

- 1) Loosen the screws of the terminal cover. To remove the terminal cover, put your finger in the dimple of the terminal cover and then pull it up toward you.
- 2) Pull out the wiring guide toward you.
- 3) After routing the wires, attach the wiring guide and the terminal cover reversing the steps above.

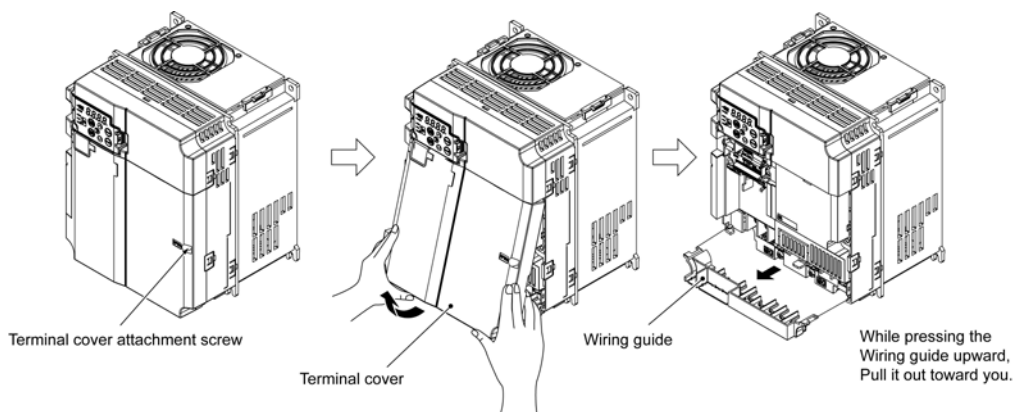

Figure 2.2-4 Removal of the Terminal Cover and the Wiring Guide (for FRN0069E2-2□)

(3) Types FRN0088E2-2□/ FRN0115E2-2□/ FRN0072E2-4□/ FRN0085E2-4□

- 1) Loosen the screws of the front cover. Hold both sides of the front cover with the hands, slide the cover downward, and pull. Then remove it to the upward direction.
- 2) Push the wiring guide upward and pull. Let the wiring guide slide and remove it.
- 3) After routing the wires, attach the wiring guide and the front cover reversing the steps above.

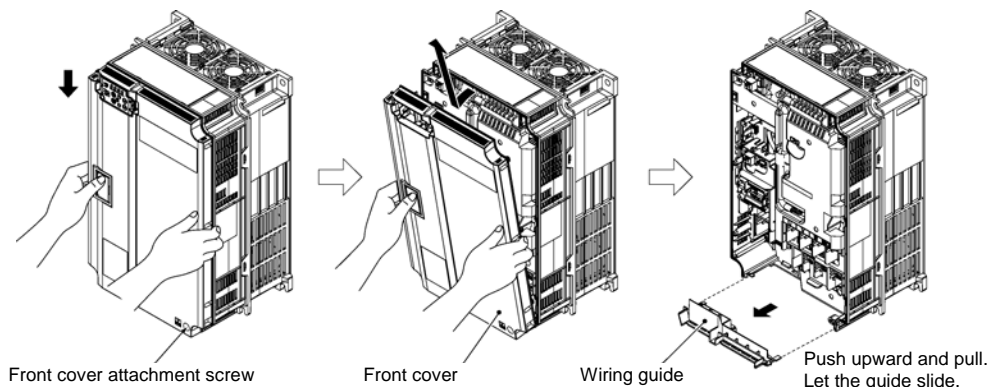

Figure 2.2-5 Removal of the Front Cover and the Wiring Guide (for FRN0072E2-4□)

(4) Types FRN0085E2-4□ or above

- 1) Loosen the screws of the front cover. Hold both sides of the front cover with the hands and slide it upward to remove.
- 2) After routing the wires, align the front cover top edge to the screw holes and attach the cover reversing the steps in Figure 2.2-6.

Tip Open the keypad case to view the control printed circuit board.

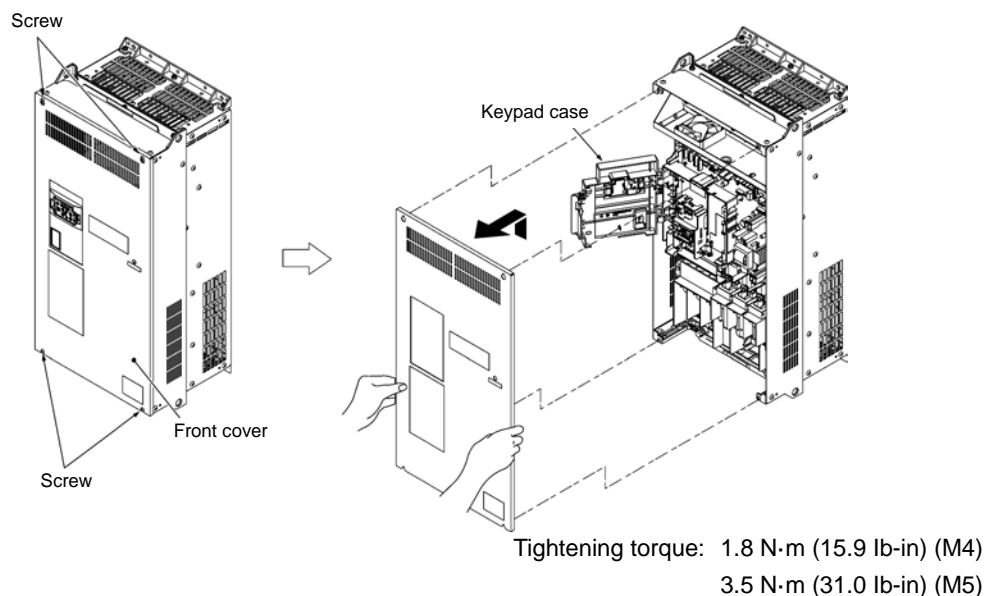
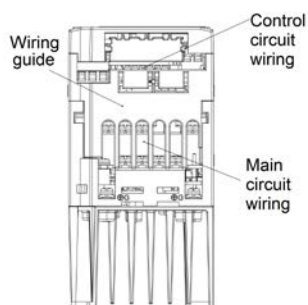

Figure 2.2-6 Removal of the front cover (for FRN0203E2-4□)

2.2.3 Precautions for wiring

Exercise caution for the following when wiring.

- (1) Confirm that the supply voltage is within the input voltage range described on the rating plate.
- (2) Always connect the power lines to the inverter main power input terminals L1/R, L2/S, L3/T (Three-phase). (The inverter will be damaged when power is applied if the power lines are connected to the wrong terminals.)
- (3) Always route the ground line to prevent accidents such as electric shock and fire and to reduce noise.
- (4) For the lines connecting to the main circuit terminals, use crimped terminals with insulating sleeves or use crimped terminals in conjunction with insulating sleeves for high connection reliability.
- (5) Separate the routing of the lines connected to the main circuit input side terminals (primary side) and the output side terminals (secondary side) and the lines connected to the control circuit terminals.
The control circuit terminal lines should be routed as far as possible from the main circuit routing. Malfunction may occur due to noise.
- (6) To prevent direct contact with the main circuit live sections (such as the main circuit terminal block), route the control circuit wiring inside the inverter as bundles using cable ties.
- (7) After removing a main circuit terminal screw, always restore the terminal screw in position and tighten even if lines are not connected.
- (8) The wiring guide is used to separately route the main circuit wiring and the control circuit wiring. The main circuit wiring and the control circuit wiring can be separated. Exercise caution for the order of wiring.



Case of FRN0006E2S-2□

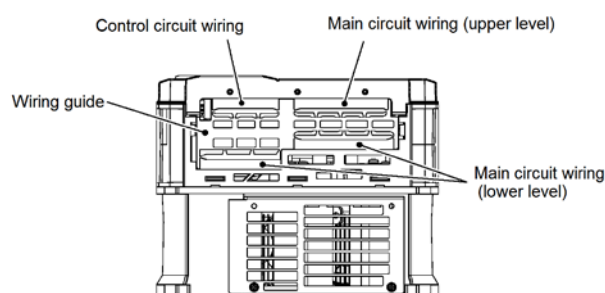

Case of FRN0072E2□-4□

■ Handling the Wiring Guide

For inverter types FRN0001 to 0115E2□-2□ and FRN0002 to 0072 E2□-4□, the wiring space may become insufficient when routing the main circuit wires, depending on the wire material used. In these cases, the relevant cut-off sections (see Figure 2.2-7, Figure 2.2-8) can be removed using a pair of nippers to secure routing space. Be warned that removing the wiring guide to accommodate the enlarged main circuit wiring will result in non-conformance to IP20 requirements.

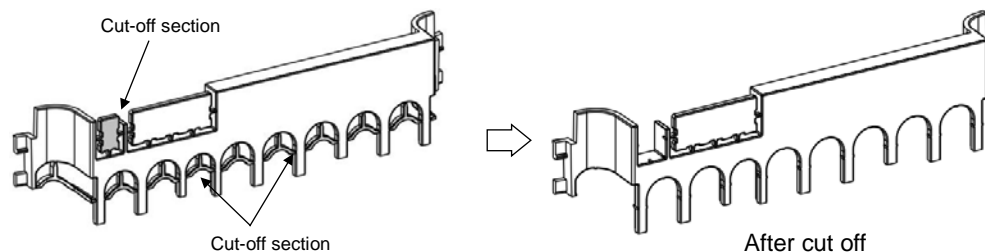

Figure 2.2-7 Wiring Guide (FRN0069E2□-2□)

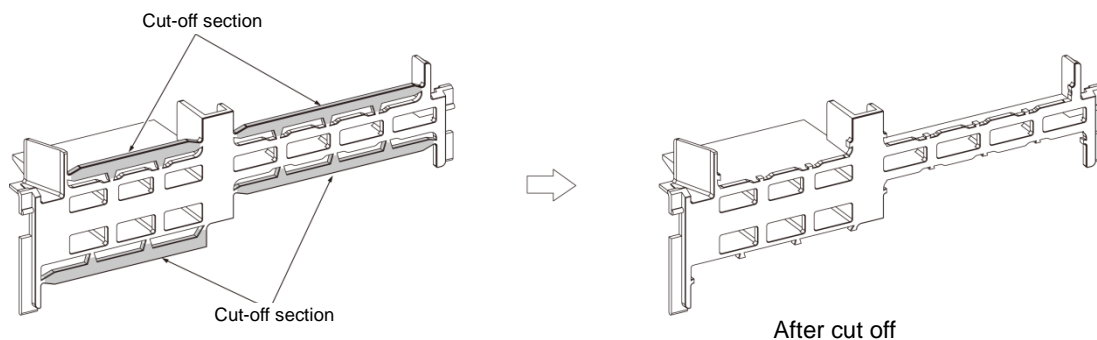
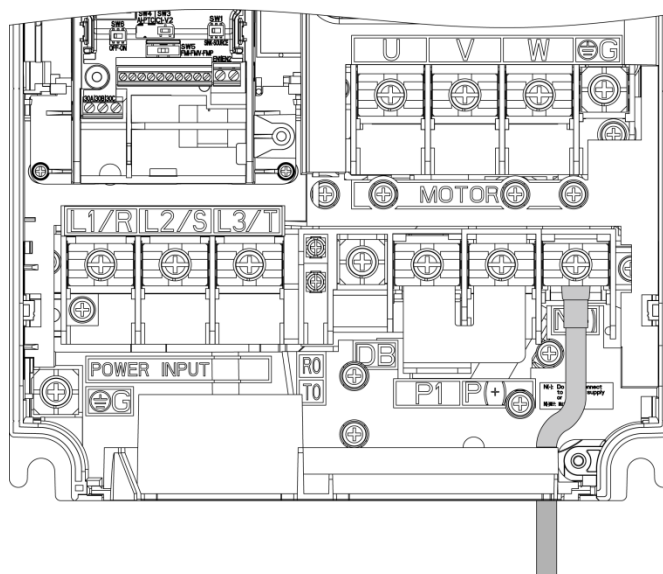

Figure 2.2-8 Wiring Guide (FRN0072E2-4□)

- (9) Depending on the inverter capacity, straight routing of the main circuit wires from the main circuit terminal block may not be possible. In these cases, route the wires as shown in the figure below and securely attach the front cover.



2.2.4 Precautions for long wiring (between inverter and motor)

- (1) When multiple motors are connected to one inverter, the wiring length is the total of all wire lengths.
- (2) Precautions shall be taken for high frequency leak current when the wiring length from the inverter to the motor is long, in this case the high frequency current may flow through the stray capacitance between the wires with various phases. The effect may cause the inverter to become overheated, or trip due to overcurrent. Leak current may increase and the accuracy of the displayed current may not be ensured. Depending on the conditions, excessive leak current may damage the inverter. To avoid the above problems when directly connecting an inverter to a motor, keep the wiring distance 50 m (164 ft) for inverters FRN0020E2-2□ / FRN0012E2-4□ / FRN0011E2-7□ or below, and below 100 m (328 ft) for inverters FRN0030E2-2□ / FRN0022E2-4□ or above.

To operate with longer wiring lengths than the ones above mentioned, reduce the carrier frequency or use an output circuit filter (OFL-□□□-□A).

When multiple motors are operated in parallel connection configuration (group operation), and especially when shielded cables are used in the connections, the stray capacitance to ground is large. Reduce the carrier frequency or use output circuit filters (OFL-□□□-□A).

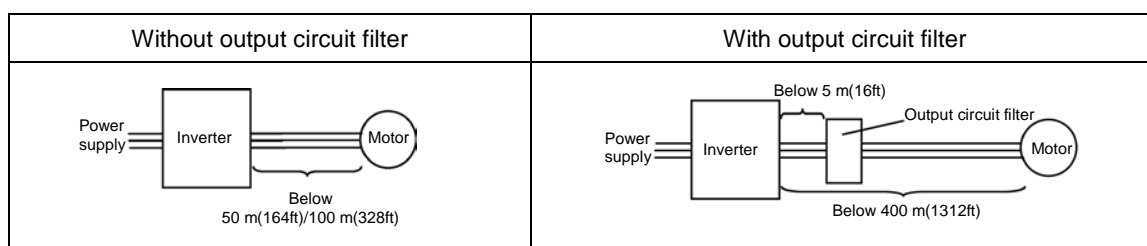

When the output circuit filter is used, the total wiring length should be below 400 m (1312ft) in case of using V/f control.

For motors with encoders, the wiring length between the inverter and motor should be below 100 m (328ft). The restriction comes from the encoder specifications. For distances beyond 100 m (328ft), insulation converters should be used. Please contact Fuji Electric when operating with wiring lengths beyond the upper limit.

- (3) Precautions on the surge voltage when driving the inverter (especially for 400 V series motor)
When motors are driven by inverters using the PWM method, the surge voltage generated by the switching of the inverter elements is added to the output voltage and is applied onto the motor terminals. Especially when the motor wiring length is long, the surge voltage can cause insulation degradation in the motor. Please perform one of the countermeasures shown below.
- Use motor with insulation enhancement (Fuji's standard motors have insulation enhancements)
 - Connect a surge suppression unit on the motor side (SSU50/100TA-NS)
 - Connect an output circuit filter (OFL-□□□-□A) to the inverter output side (secondary side)
 - Reduce the wiring length from the inverter to the motor to less than 10 to 20 meters (33 to 66ft).
- (4) When output circuit filters are attached to the inverter or when the wiring length is long, the voltage applied to the motor will decrease due to the voltage drop caused by the filter or wiring. In these cases, current oscillation and lack of torque may occur due to insufficient voltage.

⚠ WARNING ⚠

- For each inverter, connect to the power supply via circuit breaker and earth leakage breaker (with overcurrent protective function). Use recommended circuit breakers and earth leakage breakers and do not use breakers which exceed the recommended rated current.
- Always use the specified sizes for the wires.
- Tighten terminals with the defined tightening torque.
- When multiple combinations of inverters and motors exist, do not use multi-core cables for the purpose of bundling the various wires.
- Do not install surge killers on the inverter output side (secondary side)

Risk of fire exists.

- Ground the inverter in compliance with the national or local electric code.
- Always connect the ground line to the inverter grounding terminal [⚡G]

Risk of electric shock and risk of fire exist.

- Qualified personnel should perform the wiring.
- Perform wiring after confirming that the power is shut off.

Risk of electric shock exists.

- Perform wiring only after the equipment is installed at the location.

Risk of electric shock and risk of injury exist.

- Confirm that the specifications (number of phases and the rated voltage) of the power supply input of the product match with the specifications of the power supply to be connected.
- Do not connect power supply lines to the inverter output terminals (U, V, W).

Risk of fire and risk of accidents exist.

2.2.5 Main circuit terminals

[1] Screw specifications

The specifications for the screws used in the main circuit wiring and the wire sizes are shown below. Exercise caution as the terminal position varies depending on inverter capacity. In the diagram in “[2] Terminal layout diagram (main circuit terminal)”, the two ground terminals [⊕G] are not differentiated for the input side (primary side) and the output side (secondary side).

Also, use crimped terminals with insulating sleeves compatible for main circuit or terminals with insulating tubes. The recommended wire sizes are shown depending on cabinet temperature and wire type.

Table 2.2-1 Screw Specifications (Three-phase 200V series, Basic type)

Power System	Inverter type	See item [2]	Screw specifications							
			Main circuit		Grounding		Auxiliary power input for control [R0, T0]		Auxiliary power input for fan [R1, T1]	
			Screw size (driver size)	Tightening torque N·m (lb-in)	Screw size (driver size)	Tightening torque N·m (lb-in)	Screw size	Tightening torque N·m (lb-in)	Screw size	Tightening torque N·m (lb-in)
Three-phase 200 V	FRN0001E2S-2□	Fig. a	M3.5	0.8 (7.1)	M3.5	1.2 (10.6)	—	—	—	—
	FRN0002E2S-2□									
	FRN0004E2S-2□									
	FRN0006E2S-2□									
	FRN0010E2S-2□	Fig. b	M4	1.2 (10.6)	M4	1.8 (15.9)				
	FRN0012E2S-2□									
	FRN0020E2S-2□	Fig. c								
	FRN0030E2S-2□	Fig. A	M5	3.0 (26.6)	M5	3.0 (26.6)				
	FRN0040E2S-2□									
	FRN0056E2S-2□	Fig. B	M6 (No.3)	5.8 (51.3)	M6 (No.3)	5.8 (51.3)				
	FRN0069E2S-2□									
	FRN0088E2S-2□	Fig. C	M6 (No.3)	5.8 (51.3)	M6 (No.3)	5.8 (51.3)				
FRN0115E2S-2□										

Table 2.2-2 Screw Specifications (Three-phase 200V series, EMC filter built-in type)

Power System	Inverter type	See item [2]	Screw specifications							
			Main circuit		Grounding		Auxiliary power input for control [R0, T0]		Auxiliary power input for fan [R1, T1]	
			Screw size (driver size)	Tightening torque N·m (lb-in)	Screw size (driver size)	Tightening torque N·m (lb-in)	Screw size	Tightening torque N·m (lb-in)	Screw size	Tightening torque N·m (lb-in)
Three-phase 200 V	FRN0001E2E-2□	Fig. a	M3.5	0.8 (7.1)	M3.5	1.2 (10.6)	—	—	—	—
	FRN0002E2E-2□									
	FRN0004E2E-2□									
	FRN0006E2E-2□									
	FRN0010E2E-2□	Fig. h	M4	1.2 (10.6)	M4	1.8 (15.9)				
	FRN0012E2E-2□									
	FRN0020E2E-2□									
	FRN0030E2E-2□	Fig. i	Input: M4 Other: M5	Input: 1.8(15.9) Other: 3.0(26.6)	M5	3.0 (26.6)				
	FRN0040E2E-2□									
	FRN0056E2E-2□	Fig. j	M6 (No.3)	Input: 8.1(71.7) Other: 5.8(51.3)	M6 (No.3)	5.8 (51.3)				
	FRN0069E2E-2□									
	FRN0088E2E-2□	Fig. C	M6 (No.3)	5.8 (51.3)	M6 (No.3)	5.8 (51.3)				
FRN0115E2E-2□										

Table 2.2-3 Screw Specifications (Three-phase 400V series, Basic type)

Power System	Inverter type	See item [2]	Screw specifications							
			Main circuit		Grounding		Auxiliary power input for control [R0, T0]		Auxiliary power input for fan [R1, T1]	
			Screw size (driver size)	Tightening torque N·m (lb-in)	Screw size (driver size)	Tightening torque N·m (lb-in)	Screw size	Tightening torque N·m (lb-in)	Screw size	Tightening torque N·m (lb-in)
Three-phase 400 V	FRN0002E2S-4□	Fig. b	M4	1.2 (10.6)	M4	1.8 (15.9)	-	-	-	-
	FRN0004E2S-4□									
	FRN0006E2S-4□									
	FRN0007E2S-4□									
	FRN0012E2S-4□	Fig. c	M5	3.0 (26.6)	M5	3.0 (26.6)				
	FRN0022E2S-4□									
	FRN0029E2S-4□									
	FRN0037E2S-4□									
	FRN0044E2S-4□	Fig. B	M6 (No. 3)	5.8 (51.3)	M6 (No.3)	5.8 (51.3)				
	FRN0059E2S-4□									
	FRN0072E2S-4□	Fig. C	M6 (No. 3)	5.8 (51.3)	M6 (No.3)	5.8 (51.3)				
	FRN0085E2S-4□									
	FRN0105E2S-4□	Fig. D	M8	13.5 (119)	M8	13.5 (119)				
	FRN0139E2S-4□									
	FRN0168E2S-4□									
	FRN0203E2S-4□									
	FRN0240E2S-4□	Fig. E	M10	27 (239)	M10	27 (239)				
	FRN0290E2S-4□									
FRN0361E2S-4□	Fig. G	M12	48 (425)	M10	27 (239)					
FRN0415E2S-4□										
FRN0520E2S-4□										
FRN0590E2S-4□										

Table 2.2-4 Screw Specifications (Three-phase 400V series, EMC filter built-in type)

Power System	Inverter type	See item [2]	Screw specifications							
			Main circuit		Grounding		Auxiliary power input for control [R0, T0]		Auxiliary power input for fan [R1, T1]	
			Screw size (driver size)	Tightening torque N·m (lb-in)	Screw size (driver size)	Tightening torque N·m (lb-in)	Screw size	Tightening torque N·m (lb-in)	Screw size	Tightening torque N·m (lb-in)
Three-phase 400 V	FRN0002E2E-4□	Fig. g	M4	1.2 (10.6)	M4	1.8 (15.9)	-	-	-	-
	FRN0004E2E-4□									
	FRN0006E2E-4□	Fig. h								
	FRN0007E2E-4□									
	FRN0012E2E-4□	Fig. i	Input M4 Output M5	Input: 1.8(15.9) Other: 3.0(26.6)	M5	3.0 (26.6)				
	FRN0029E2E-4□									
	FRN0037E2E-4□	Fig. j	Input M4 Output M6	Input: 1.8(15.9) Other: 5.8(51.3)	M6 (No.3)	5.8 (51.3)				
	FRN0044E2E-4□									
	FRN0059E2E-4□	Fig. C	M6 (No. 3)	5.8 (51.3)	M6 (No.3)	5.8 (51.3)				
	FRN0072E2E-4□									
	FRN0085E2E-4□	Fig. D	M8	13.5 (119)	M8	13.5 (119)				
	FRN0105E2E-4□									
	FRN0139E2E-4□									
	FRN0168E2E-4□									
	FRN0203E2E-4□	Fig. E	M10	27 (239)	M10	27 (239)				
	FRN0240E2E-4□									
	FRN0290E2E-4□	Fig. F	M12	48 (425)	M10	27 (239)				
	FRN0361E2E-4□									
FRN0415E2E-4□										
FRN0520E2E-4□										
FRN0590E2E-4□	Fig. H									

Table 2.2-5 Screw Specifications (Single-phase 200V series, Basic type)

Power System	Inverter type	See item [2]	Screw specifications							
			Main circuit		Grounding		Auxiliary power input for control [R0, T0]		Auxiliary power input for fan [R1, T1]	
			Screw size (driver size)	Tightening torque N·m (lb-in)	Screw size (driver size)	Tightening torque N·m (lb-in)	Screw size	Tightening torque N·m (lb-in)	Screw size	Tightening torque N·m (lb-in)
Single-phase 200 V	FRN0001E2S-7□	Fig. k	M3.5	0.8 (7.1)	M3.5	1.2 (10.6)	-	-	-	-
	FRN0002E2S-7□									
	FRN0003E2S-7□									
	FRN0005E2S-7□									
	FRN0008E2S-7□	Fig. l	M4	1.2 (10.6)	M4	1.8 (15.9)				
	FRN0011E2S-7□	Fig. m								

Table 2.2-6 Screw Specifications (Single-phase 200V series, EMC filter built-in type)

Power System	Inverter type	See item [2]	Screw specifications							
			Main circuit		Grounding		Auxiliary power input for control [R0, T0]		Auxiliary power input for fan [R1, T1]	
			Screw size (driver size)	Tightening torque N·m (lb-in)	Screw size (driver size)	Tightening torque N·m (lb-in)	Screw size	Tightening torque N·m (lb-in)	Screw size	Tightening torque N·m (lb-in)
Single-phase 200 V	FRN0001E2E-7□	Fig. k	M3.5	0.8 (7.1)	M3.5	1.2 (10.6)	-	-	-	-
	FRN0002E2E-7□									
	FRN0003E2E-7□									
	FRN0005E2E-7□	Fig. n	M4	1.2 (10.6)	M4	1.8 (15.9)				
	FRN0008E2E-7□	Fig. h								
	FRN0011E2E-7□									

[2] Terminal layout diagram (main circuit terminal)

Figure A

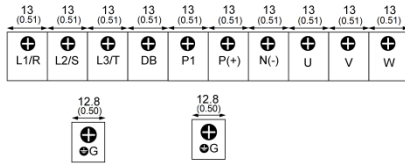

Figure B

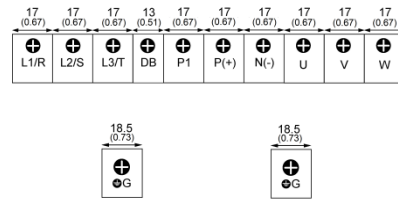

Figure C

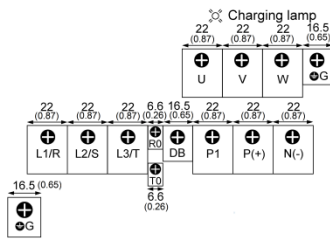

Figure D

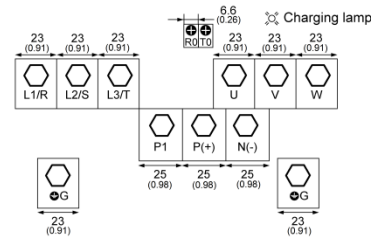

Figure E / Figure F

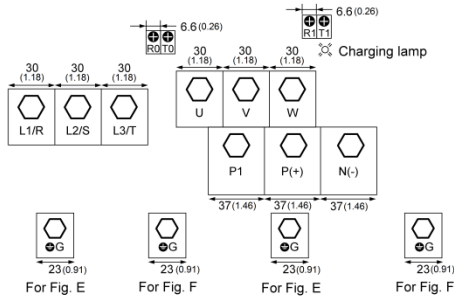
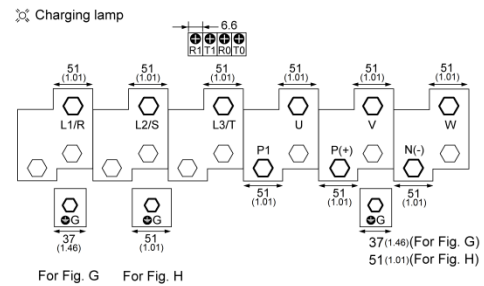

Figure G / Figure H



⚠ WARNING ⚠

The following terminals will have high voltage when power is ON.

Main circuit: L1/R, L2/S, L3/T, L1/L, L2/N, P1, P(+), N(-), DB, U, V, W, R0, T0, R1, T1

Insulation level

Main circuit - Casing : Basic insulation (overvoltage category III, degree of contamination 2)

Main circuit - Control circuit : Enhanced insulation (overvoltage category III, degree of contamination 2)

Risk of electric shock exists

Figure a

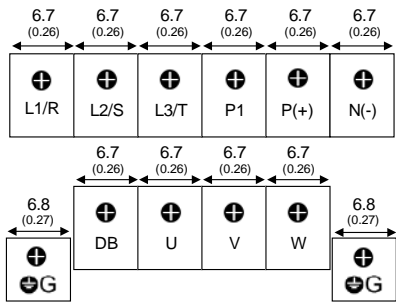

Figure b

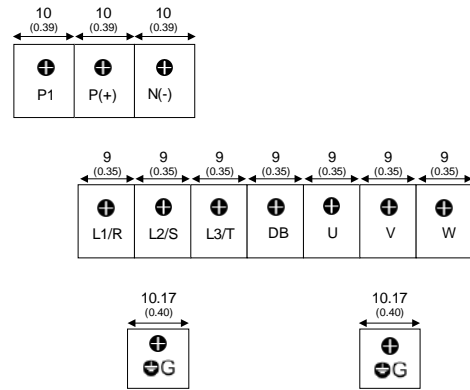

Figure c

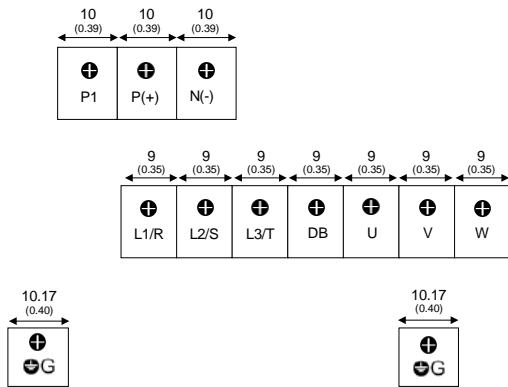

Figure i

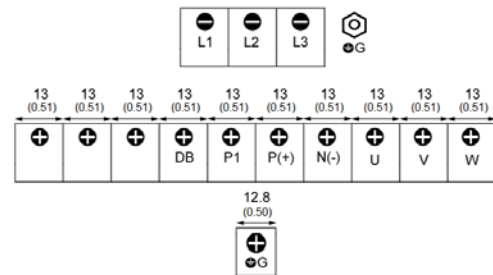

Figure j

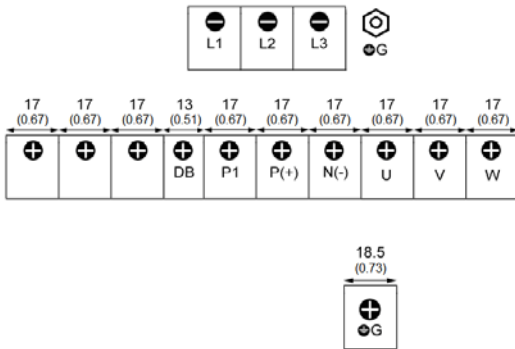

Figure k

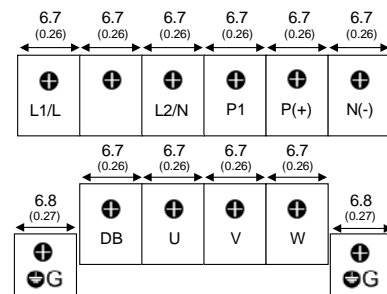

Figure l

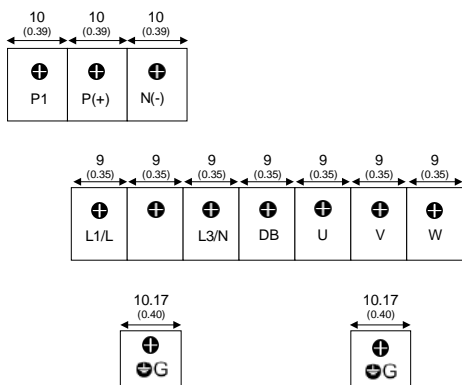
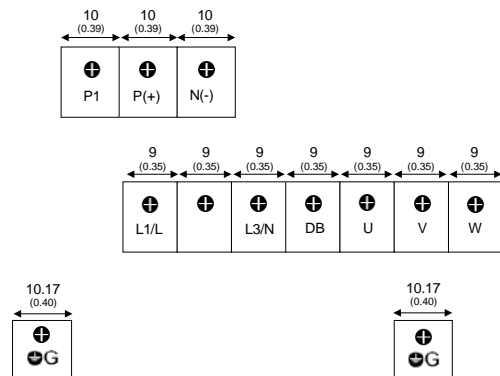

Figure m



For the figure g / h / n, please contact Fuji Electric.

[3] Recommended wire size (main circuit terminals)

The following wires are recommended unless special requirements exist.

■ **600 V vinyl insulation wire (IV wire)**

This wire is used in circuits except the inverter control circuit. The wire is difficult to twist and is not recommended for inverter control circuit. The maximum allowable temperature for the insulated wire is 60°C.

■ **600 V type 2 vinyl insulation wire or 600 V polyethylene insulation wire (HIV wire)**

In comparison to the IV wire, this wire is smaller, more flexible, and the maximum allowable temperature for the insulated wire is 75°C (higher), making it suitable for both the inverter main circuit and control circuit. However, the wiring distance should be short and the wire must be twisted for use in the inverter control circuit.

■ **600 V cross-linked polyethylene insulation wire (FSLC wire)**

This wire is used mainly in the main circuit and the grounding circuits. The size is even smaller than the IV wire or the HIV wire and also more flexible. Due to these features, the wire is used to reduce the area occupied by wiring and to improve work efficiency in high temperature areas. The maximum allowable temperature for the insulated wire is 90°C. As a reference, Furukawa Electric Co., Ltd. produces Boardlex which satisfies these requirements.

■ **Shielded-Twisted cables for internal wiring of electronic/electric instruments**

This product is used in inverter control circuits. Use this wire with high shielding effect when risk of exposure to or effect of radiated noise and induced noise exists. Always use this wire when the wiring distance is long, even within the cabinet. Furukawa Electric's BEAMEX S shielded cables XEBV or XEWV satisfy these requirements.

Table 2.2-7 Recommended Wire Sizes (Common Terminals)

Common terminals	Recommended wire size (mm ²) [AWG]	Remarks
Auxiliary power input terminals for control circuit R0, T0	2.0 [14]	FRN0088E2■-2□ or above FRN0059E2■-4□ or above
Auxiliary power input terminals for fan R1, T1	2.0 [14]	FRN0203E2■-4□ or above

Refer to Appendix G-3 to conform the wire sizes to the UL Standards and Canadian Standards (cUL Certification).

(1) Wire sizes conforming to low voltage directive in Europe

Table 2.2-8 Recommended Wire Sizes, conforming to low voltage directive in Europe

ND Mode, Conforming to low voltage directive in Europe

Power System	Std Applicable Motor (kW)	Inverter type	Recommended wire size (mm ²)						
			Main power supply input [L1/R, L2/S, L3/T]		Ground terminal [G]		Inverter output [U, V, W]	For DC reactor connection [P1, P(+)]	For braking resistor connection [P(+), DB]
			With DC reactor	Without DC reactor	With DC reactor	Without DC reactor			
Three-phase 400 V	0.75	FRN0002E2■-4□	2.5	2.5	2.5	2.5	2.5	2.5	2.5
	1.5	FRN0004E2■-4□	2.5	2.5	2.5	2.5	2.5	2.5	2.5
	2.2	FRN0006E2■-4□	2.5	2.5	2.5	2.5	2.5	2.5	2.5
	3.0	FRN0007E2■-4□	2.5	2.5	2.5	2.5	2.5	2.5	2.5
	5.5	FRN0012E2■-4□	2.5	2.5	2.5	2.5	2.5	2.5	2.5
	11	FRN0022E2■-4□	4	6	4	6	4	4	2.5
	15	FRN0029E2■-4□	6	10	6	10	6	6	2.5
	18.5	FRN0037E2■-4□	6	16	6	16	10	10	2.5
	22	FRN0044E2■-4□	10	16	10	16	10	16	2.5
	30	FRN0059E2■-4□	16	25	16	16	16	25	2.5
	37	FRN0072E2■-4□	25	35	16	16	25	25	2.5
	45	FRN0085E2■-4□	25	50	16	25	35	35	-
	55	FRN0105E2■-4□	35	70	16	35	50	50	-
	75	FRN0139E2■-4□	70	-	35	-	70	95	-
	90	FRN0168E2■-4□	95	-	50	-	95	120	-
	110	FRN0203E2■-4□	120	-	70	-	120	150	-
	132	FRN0240E2■-4□	150	-	95	-	150	95x2	-
	160	FRN0290E2■-4□	95x2	-	95	-	95x2	120x2	-
200	FRN0361E2■-4□	300	-	150	-	300	150x2	-	
220	FRN0415E2■-4□	300	-	150	-	150x2	185x2	-	
280	FRN0520E2■-4□	185x2	-	185	-	240x2	300x2	-	
315	FRN0590E2■-4□	240x2	-	240	-	240x2	300x2	-	

HD Mode, Conforming to low voltage directive in Europe

Power System	Std Applicable Motor (kW)	Inverter type	Recommended wire size (mm ²)						
			Main power supply input [L1/R, L2/S, L3/T]		Ground terminal [G]		Inverter output [U, V, W]	For DC reactor connection [P1, P(+)]	For braking resistor connection [P(+), DB]
			With DC reactor	Without DC reactor	With DC reactor	Without DC reactor			
Three-phase 400 V	0.75	FRN0002E2■-4□	2.5	2.5	2.5	2.5	2.5	2.5	2.5
	1.1	FRN0004E2■-4□	2.5	2.5	2.5	2.5	2.5	2.5	2.5
	2.2	FRN0006E2■-4□	2.5	2.5	2.5	2.5	2.5	2.5	2.5
	3.0	FRN0007E2■-4□	2.5	2.5	2.5	2.5	2.5	2.5	2.5
	5.5	FRN0012E2■-4□	2.5	2.5	2.5	2.5	2.5	2.5	2.5
	7.5	FRN0022E2■-4□	2.5	4	2.5	4	2.5	2.5	2.5
	11	FRN0029E2■-4□	4	6	4	6	4	4	2.5
	15	FRN0037E2■-4□	6	10	6	10	6	6	2.5
	18.5	FRN0044E2■-4□	6	16	6	16	10	10	2.5
	22	FRN0059E2■-4□	10	16	10	16	10	16	2.5
	30	FRN0072E2■-4□	16	25	16	16	16	25	2.5
	37	FRN0085E2■-4□	25	35	16	16	25	25	-
	45	FRN0105E2■-4□	25	50	16	25	35	35	-
	55	FRN0139E2■-4□	35	70	16	35	50	50	-
	75	FRN0168E2■-4□	70	-	35	-	70	95	-
	90	FRN0203E2■-4□	95	-	50	-	95	120	-
	110	FRN0240E2■-4□	120	-	70	-	120	150	-
	132	FRN0290E2■-4□	150	-	95	-	150	95x2	-
160	FRN0361E2■-4□	185	-	95	-	240	300	-	
200	FRN0415E2■-4□	300	-	150	-	300	150x2	-	
220	FRN0520E2■-4□	300	-	150	-	150x2	185x2	-	
250	FRN0590E2■-4□	185x2	-	185	-	185x2	240x2	-	

The recommended wire sizes for the main circuit terminals assume using 70°C 600 V PVC wire at 40°C ambient temperature.

Table 2.2-9 Recommended Wire Sizes, conforming to low voltage directive in Europe (continued)

HND Mode, Conforming to low voltage directive in Europe

Power System	Std Applicable Motor (kW)	Inverter type	Recommended wire size (mm ²)						
			Main power supply input [L1/R, L2/S, L3/T]		Ground terminal [G]		Inverter output [U, V, W]	For DC reactor connection [P1, P(+)]	For braking resistor connection [P(+), DB]
			With DC reactor	Without DC reactor	With DC reactor	Without DC reactor			
Three-phase 400 V	0.75	FRN0002E2-4□	2.5	2.5	2.5	2.5	2.5	2.5	2.5
	1.1	FRN0004E2-4□	2.5	2.5	2.5	2.5	2.5	2.5	2.5
	2.2	FRN0006E2-4□	2.5	2.5	2.5	2.5	2.5	2.5	2.5
	3.0	FRN0007E2-4□ ^{*10}	2.5	2.5	2.5	2.5	2.5	2.5	2.5
	5.5	FRN0012E2-4□ ^{*10}	2.5	2.5	2.5	2.5	2.5	2.5	2.5
	7.5	FRN0022E2-4□	2.5	4	2.5	4	2.5	2.5	2.5
	11	FRN0029E2-4□	4	6	4	6	4	4	2.5
	15	FRN0037E2-4□	6	10	6	16	6	6	2.5
	18.5	FRN0044E2-4□	6	16	10	16	10	10	2.5
	22	FRN0059E2-4□	10	16	10	16	10	16	2.5
	30	FRN0072E2-4□	16	25	16	16	16	25	2.5
	37	FRN0085E2-4□	25	35	16	16	25	25	-
	45	FRN0105E2-4□	25	50	16	25	35	35	-
	55	FRN0139E2-4□	35	70	16	35	50	50	-
	75	FRN0168E2-4□	70	-	35	-	70	95	-
	90	FRN0203E2-4□	95	-	50	-	95	120	-
	110	FRN0240E2-4□	120	-	70	-	120	150	-
	132	FRN0290E2-4□	150	-	95	-	150	95x2	-
160	FRN0361E2-4□	185	-	95	-	240	300	-	
200	FRN0415E2-4□	300	-	150	-	300	150x2	-	
220	FRN0520E2-4□	300	-	150	-	150x2	185x2	-	
280	FRN0590E2-4□	185x2	-	185	-	240x2	300x2	-	

HND Mode, Conforming to low voltage directive in Europe

Power System	Std Applicable Motor (kW)	Inverter type	Recommended wire size (mm ²)						
			Main power supply input [L1/R, L2/S, L3/T]		Ground terminal [G]		Inverter output [U, V, W]	For DC reactor connection [P1, P(+)]	For braking resistor connection [P(+), DB]
			With DC reactor	Without DC reactor	With DC reactor	Without DC reactor			
Three-phase 400 V	0.4	FRN0002E2-4□	2.5	2.5	2.5	2.5	2.5	2.5	2.5
	0.75	FRN0004E2-4□	2.5	2.5	2.5	2.5	2.5	2.5	2.5
	1.5	FRN0006E2-4□	2.5	2.5	2.5	2.5	2.5	2.5	2.5
	2.2	FRN0007E2-4□	2.5	2.5	2.5	2.5	2.5	2.5	2.5
	3.7	FRN0012E2-4□	2.5	2.5	2.5	2.5	2.5	2.5	2.5
	5.5	FRN0022E2-4□	2.5	2.5	2.5	2.5	2.5	2.5	2.5
	7.5	FRN0029E2-4□	2.5	4	2.5	4	2.5	2.5	2.5
	11	FRN0037E2-4□	4	6	4	6	4	4	2.5
	15	FRN0044E2-4□	6	10	6	10	6	6	2.5
	18.5	FRN0059E2-4□	6	16	10	16	10	10	2.5
	22	FRN0072E2-4□	10	16	10	16	10	16	2.5
	30	FRN0085E2-4□	16	25	16	16	16	25	-
	37	FRN0105E2-4□	25	35	16	16	25	25	-
	45	FRN0139E2-4□	25	50	16	25	35	35	-
	55	FRN0168E2-4□	35	70	16	35	50	50	-
	75	FRN0203E2-4□	70	-	35	-	70	95	-
	90	FRN0240E2-4□	95	-	50	-	95	120	-
	110	FRN0290E2-4□	120	-	70	-	120	150	-
132	FRN0361E2-4□	150	-	95	-	150	185	-	
160	FRN0415E2-4□	185	-	95	-	240	300	-	
200	FRN0520E2-4□	300	-	150	-	300	150x2	-	
220	FRN0590E2-4□	300	-	150	-	150x2	185x2	-	
Single-phase 200V	0.1	FRN0001E2-7□	2.5	2.5	2.5	2.5	2.5	2.5	2.5
	0.2	FRN0002E2-7□	2.5	2.5	2.5	2.5	2.5	2.5	2.5
	0.4	FRN0003E2-7□	2.5	2.5	2.5	2.5	2.5	2.5	2.5
	0.75	FRN0005E2-7□	2.5	2.5	2.5	2.5	2.5	2.5	2.5
	1.5	FRN0008E2-7□	2.5	2.5	2.5	2.5	2.5	2.5	2.5
	2.2	FRN0011E2-7□	2.5	4	2.5	4	2.5	2.5	2.5

The recommended wire sizes for the main circuit terminals assume using 70°C 600 V PVC wire at 40°C ambient temperature.

*10 ND-spec.

(2) Recommended Wire Sizes

1) Ambient temperature: Below 40°C, Wire type: 60°C wire

Table 2.2-10 Recommended wire size, Ambient temperature: Below 40°C, Wire type: 60°C wire

ND Mode, Ambient temperature: Below 40°C, Wire type: 60°C wire

Power System	Std Applicable Motor (kW)	Inverter type	Recommended wire size (mm ²)					
			Main power supply input [L1/R, L2/S, L3/T]		Ground terminal [G]	Inverter output [U, V, W]	For DC reactor connection [P1, P(+)]	For braking resistor connection [P(+), DB]
			With DC reactor	Without DC reactor				
Three-phase 400 V	0.75	FRN0002E2-4□	2	2	2	2	2	2
	1.5	FRN0004E2-4□	2	2	2	2	2	2
	2.2	FRN0006E2-4□	2	2	2	2	2	2
	3.0	FRN0007E2-4□	2	2	2	2	2	2
	5.5	FRN0012E2-4□	2	2	2	2	2	2
	11	FRN0022E2-4□	2	5.5	3.5	2	3.5	2
	15	FRN0029E2-4□	3.5	8	5.5	3.5	5.5	2
	18.5	FRN0037E2-4□	5.5	14	5.5	5.5	8	2
	22	FRN0044E2-4□	8	14	5.5	8	14	2
	30	FRN0059E2-4□	14	22	8 ^{*1}	14	14	2
	37	FRN0072E2-4□	14	38	8 ^{*1}	14	22	2
	45	FRN0085E2-4□	22	38	8	22	38	-
	55	FRN0105E2-4□	38	60	14	38	38	-
	75	FRN0139E2-4□	60	-	14	60	60	-
	90	FRN0168E2-4□	60	-	14	60	100 ^{*2}	-
	110	FRN0203E2-4□	100	-	22	100	-	-
	132	FRN0240E2-4□	100	-	22	100	-	-
	160	FRN0290E2-4□	-	-	22	-	-	-
	200	FRN0361E2-4□	-	-	38	-	-	-
220	FRN0415E2-4□	-	-	38	-	-	-	
280	FRN0520E2-4□	-	-	38	-	-	-	
315	FRN0590E2-4□	-	-	60	-	-	-	

HD Mode, Ambient temperature: Below 40°C, Wire type: 60°C wire

Power System	Std Applicable Motor (kW)	Inverter type	Recommended wire size (mm ²)					
			Main power supply input [L1/R, L2/S, L3/T]		Ground terminal [G]	Inverter output [U, V, W]	For DC reactor connection [P1, P(+)]	For braking resistor connection [P(+), DB]
			With DC reactor	Without DC reactor				
Three-phase 400 V	0.75	FRN0002E2-4□	2	2	2	2	2	2
	1.1	FRN0004E2-4□	2	2	2	2	2	2
	2.2	FRN0006E2-4□	2	2	2	2	2	2
	3.0	FRN0007E2-4□	2	2	2	2	2	2
	5.5	FRN0012E2-4□	2	2	2	2	2	2
	7.5	FRN0022E2-4□	2	3.5	2	2	2	2
	11	FRN0029E2-4□	2	5.5	3.5	3.5	3.5	2
	15	FRN0037E2-4□	3.5	8	5.5	5.5	5.5	2
	18.5	FRN0044E2-4□	5.5	14	5.5	5.5	8	2
	22	FRN0059E2-4□	8 ^{*1}	14	5.5	8 ^{*1}	14	2
	30	FRN0072E2-4□	14	22	8 ^{*1}	14	14	2
	37	FRN0085E2-4□	14	38	8	22	22	-
	45	FRN0105E2-4□	22	38	8	22	38	-
	55	FRN0139E2-4□	38	60	14	38	38	-
	75	FRN0168E2-4□	60	-	14	60	60	-
	90	FRN0203E2-4□	60	-	14	60	100	-
	110	FRN0240E2-4□	100	-	22	100	-	-
	132	FRN0290E2-4□	100	-	22	-	-	-
	160	FRN0361E2-4□	-	-	22	-	-	-
200	FRN0415E2-4□	-	-	38	-	-	-	
220	FRN0520E2-4□	-	-	38	-	-	-	
250	FRN0590E2-4□	-	-	38	-	-	-	

The recommended wire sizes for the main circuit terminals assume using 60°C IV wire.

*1 For compatible crimped terminals, please use model 8-L6 by JST Mfg. Co., Ltd. or equivalent.

*2 For compatible crimped terminals, please use model CB100-S8 by JST Mfg. Co., Ltd. or equivalent.

Table 2.2-11 Recommended wire sizes, Ambient temperature : Below 40°C, Wire type: 60°C wire

HND Mode, Ambient temperature: Below 40°C, Wire type: 60°C wire

Power System	Std Applicable Motor (kW)	Inverter type	Recommended wire size (mm ²)					
			Main power supply input [L1/R, L2/S, L3/T]		Ground terminal [G]	Inverter output [U, V, W]	For DC reactor connection [P1, P(+)]	For braking resistor connection [P(+), DB]
			With DC reactor	Without DC reactor				
Three-phase 200 V	0.2	FRN0001E2-2□	2	2	2	2	2	2
	0.4	FRN0002E2-2□	2	2	2	2	2	2
	0.75	FRN0004E2-2□	2	2	2	2	2	2
	1.1	FRN0006E2-2□	2	2	2	2	2	2
	2.2	FRN0010E2-2□	2	2	2	2	2	2
	3.0	FRN0012E2-2□ ^{*10}	2	2	2	2	2	2
	5.5	FRN0020E2-2□ ^{*10}	2	5.5	3.5	2	3.5	2
	7.5	FRN0030E2-2□	3.5	8	5.5	3.5	5.5	2
	11	FRN0040E2-2□	8	14	5.5	5.5	14	2
	15	FRN0056E2-2□	14	22	5.5	14	14	2
	18.5	FRN0069E2-2□	14	38	8	14	22	2
	22	FRN0088E2-2□	22	38 ^{*7}	8	22	38 ^{*7}	2
30	FRN0115E2-2□	38 ^{*7}	60 ^{*8}	14	38 ^{*7}	60 ^{*8}	2	
Three-phase 400 V	0.75	FRN0002E2-4□	2	2	2	2	2	2
	1.1	FRN0004E2-4□	2	2	2	2	2	2
	2.2	FRN0006E2-4□	2	2	2	2	2	2
	3.0	FRN0007E2-4□ ^{*10}	2	2	2	2	2	2
	5.5	FRN0012E2-4□ ^{*10}	2	2	2	2	2	2
	7.5	FRN0022E2-4□	2	3.5	2	2	2	2
	11	FRN0029E2-4□	2	5.5	3.5	3.5	3.5	2
	15	FRN0037E2-4□	3.5	8	3.5	5.5	5.5	2
	18.5	FRN0044E2-4□	8	14	5.5	8	8	2
	22	FRN0059E2-4□	8 ^{*1}	14	5.5	8 ^{*1}	14	2
	30	FRN0072E2-4□	14	22	8 ^{*1}	14	14	2
	37	FRN0085E2-4□	14	38	8	22	22	-
	45	FRN0105E2-4□	22	38	8	22	38	-
	55	FRN0139E2-4□	38	60	14	38	38	-
	75	FRN0168E2-4□	60	-	14	60	60	-
	90	FRN0203E2-4□	60	-	14	60	100	-
	110	FRN0240E2-4□	100	-	22	100	-	-
132	FRN0290E2-4□	100	-	22	-	-	-	
160	FRN0361E2-4□	-	-	22	-	-	-	
200	FRN0415E2-4□	-	-	38	-	-	-	
220	FRN0520E2-4□	-	-	38	-	-	-	
280	FRN0590E2-4□	-	-	38	-	-	-	

The recommended wire sizes for the main circuit terminals assume using 60°C IV wire.

- *1 For compatible crimped terminals, please use model 8-L6 by JST Mfg. Co., Ltd. or equivalent.
- *2 For compatible crimped terminals, please use model CB100-S8 by JST Mfg. Co., Ltd. or equivalent.
- *7 For compatible crimped terminals, please use model 38-6 by JST Mfg. Co., Ltd. or equivalent.
- *8 For compatible crimped terminals, please use model 60-6 by JST Mfg. Co., Ltd. or equivalent.
- *10 ND-spec.

Table 2.2-12 Recommended wire sizes, Ambient temperature : Below 40°C, Wire type: 60°C wire (continued)

HHD Mode, Ambient temperature: Below 40°C, Wire type: 60°C wire

Power System	Std Applicable Motor (kW)	Inverter type	Recommended wire size (mm ²)					
			Main power supply input [L1/R, L2/S, L3/T]		Ground terminal [G]	Inverter output [U, V, W]	For DC reactor connection [P1, P(+)]	For braking resistor connection [P(+), DB]
			With DC reactor	Without DC reactor				
Three-phase 200 V	0.1	FRN0001E2-2□	2	2	2	2	2	2
	0.2	FRN0002E2-2□	2	2	2	2	2	2
	0.4	FRN0004E2-2□	2	2	2	2	2	2
	0.75	FRN0006E2-2□	2	2	2	2	2	2
	1.5	FRN0010E2-2□	2	2	2	2	2	2
	2.2	FRN0012E2-2□	2	2	2	2	2	2
	3.7	FRN0020E2-2□	2	3.5	2	2	2	2
	5.5	FRN0030E2-2□	2	5.5	3.5	3.5	3.5	2
	7.5	FRN0040E2-2□	3.5	8	5.5	5.5	5.5	2
	11	FRN0056E2-2□	8	14	5.5	8	14	2
	15	FRN0069E2-2□	14	22	5.5	14	14	2
	18.5	FRN0088E2-2□	14	38 ⁷	8	22	22	2
	22	FRN0115E2-2□	22	38 ⁷	8	22	38 ⁷	2
Three-phase 400 V	0.4	FRN0002E2-4□	2	2	2	2	2	2
	0.75	FRN0004E2-4□	2	2	2	2	2	2
	1.5	FRN0006E2-4□	2	2	2	2	2	2
	2.2	FRN0007E2-4□	2	2	2	2	2	2
	3.7	FRN0012E2-4□	2	2	2	2	2	2
	5.5	FRN0022E2-4□	2	2	2	2	2	2
	7.5	FRN0029E2-4□	2	3.5	2	2	2	2
	11	FRN0037E2-4□	2	5.5	3.5	3.5	3.5	2
	15	FRN0044E2-4□	3.5	8	5.5	3.5	5.5	2
	18.5	FRN0059E2-4□	5.5	14	5.5	5.5	8 ¹	2
	22	FRN0072E2-4□	8 ¹	14	5.5	8 ¹	14	2
	30	FRN0085E2-4□	14	22	8	14	14	-
	37	FRN0105E2-4□	14	38	8	22	22	-
	45	FRN0139E2-4□	22	38	8	22	38	-
	55	FRN0168E2-4□	38	60	14	38	38	-
	75	FRN0203E2-4□	60	-	14	60	60	-
	90	FRN0240E2-4□	60	-	14	60	100	-
110	FRN0290E2-4□	100	-	22	100	-	-	
132	FRN0361E2-4□	100	-	22	-	-	-	
160	FRN0415E2-4□	-	-	22	-	-	-	
200	FRN0520E2-4□	-	-	38	-	-	-	
220	FRN0590E2-4□	-	-	38	-	-	-	
Single-phase 200 V	0.1	FRN0001E2-7□	2	2	2	2	2	2
	0.2	FRN0002E2-7□	2	2	2	2	2	2
	0.4	FRN0003E2-7□	2	2	2	2	2	2
	0.75	FRN0005E2-7□	2	2	2	2	2	2
	1.5	FRN0008E2-7□	2	2	2	2	2	2
	2.2	FRN0011E2-7□	2	3.5	2	2	2	2

The recommended wire sizes for the main circuit terminals assume using 60°C IV wire.

*1 For compatible crimped terminals, please use model 8-L6 by JST Mfg. Co., Ltd. or equivalent.

2) Ambient temperature: Below 40°C, Wire type: 75°C wire

Table 2.2-13 Recommended Wire Sizes, Ambient temperature: Below 40°C, Wire type: 75°C wire (continued)

ND Mode, Ambient temperature: Below 40°C, Wire type: 75°C wire

Power System	Std Applicable Motor (kW)	Inverter type	Recommended wire size (mm ²)					
			Main power supply input [L1/R, L2/S, L3/T]		Ground terminal [⊕G]	Inverter output [U, V, W]	For DC reactor connection [P1, P(+)]	For braking resistor connection [P(+), DB]
			With DC reactor	Without DC reactor				
Three-phase 400 V	0.75	FRN0002E2■-4□	2	2	2	2	2	2
	1.5	FRN0004E2■-4□	2	2	2	2	2	2
	2.2	FRN0006E2■-4□	2	2	2	2	2	2
	3.0	FRN0007E2■-4□	2	2	2	2	2	2
	5.5	FRN0012E2■-4□	2	2	2	2	2	2
	11	FRN0022E2■-4□	2	3.5	3.5	2	2	2
	15	FRN0029E2■-4□	2	5.5	5.5	2	3.5	2
	18.5	FRN0037E2■-4□	3.5	8	5.5	3.5	5.5	2
	22	FRN0044E2■-4□	5.5	8	5.5	5.5	5.5	2
	30	FRN0059E2■-4□	8 ^{*1}	14	8 ^{*1}	8 ^{*1}	14	2
	37	FRN0072E2■-4□	14	14	8 ^{*1}	14	14	2
	45	FRN0085E2■-4□	14	22	8	14	22	-
	55	FRN0105E2■-4□	22	38	14	22	38	-
	75	FRN0139E2■-4□	38	-	14	38	38	-
	90	FRN0168E2■-4□	38	-	14	38	60	-
	110	FRN0203E2■-4□	60	-	22	60	100	-
	132	FRN0240E2■-4□	100	-	22	100	100	-
	160	FRN0290E2■-4□	100	-	22	100	150 ^{*3}	-
200	FRN0361E2■-4□	150	-	38	150	200	-	
220	FRN0415E2■-4□	150	-	38	150	200	-	
280	FRN0520E2■-4□	200	-	38	250	325	-	
315	FRN0590E2■-4□	250	-	60	250	325	-	

HD Mode, Ambient temperature: Below 40°C, Wire type: 75°C wire

Power System	Std Applicable Motor (kW)	Inverter type	Recommended wire size (mm ²)					
			Main power supply input [L1/R, L2/S, L3/T]		Ground terminal [⊕G]	Inverter output [U, V, W]	For DC reactor connection [P1, P(+)]	For braking resistor connection [P(+), DB]
			With DC reactor	Without DC reactor				
Three-phase 400 V	0.75	FRN0002E2■-4□	2	2	2	2	2	2
	1.1	FRN0004E2■-4□	2	2	2	2	2	2
	2.2	FRN0006E2■-4□	2	2	2	2	2	2
	3.0	FRN0007E2■-4□	2	2	2	2	2	2
	5.5	FRN0012E2■-4□	2	2	2	2	2	2
	7.5	FRN0022E2■-4□	2	2	2	2	2	2
	11	FRN0029E2■-4□	2	3.5	3.5	2	2	2
	15	FRN0037E2■-4□	2	5.5	5.5	3.5	3.5	2
	18.5	FRN0044E2■-4□	3.5	8	5.5	3.5	5.5	2
	22	FRN0059E2■-4□	5.5	8 ^{*1}	5.5	5.5	5.5	2
	30	FRN0072E2■-4□	8 ^{*1}	14	8 ^{*1}	8 ^{*1}	14	2
	37	FRN0085E2■-4□	14	14	8	14	14	-
	45	FRN0105E2■-4□	14	22	8	14	22	-
	55	FRN0139E2■-4□	22	38	14	22	38	-
	75	FRN0168E2■-4□	38	-	14	38	38	-
	90	FRN0203E2■-4□	38	-	14	60	60	-
	110	FRN0240E2■-4□	60	-	22	60	100	-
	132	FRN0290E2■-4□	100	-	22	100	100	-
160	FRN0361E2■-4□	100	-	22	100	150	-	
200	FRN0415E2■-4□	150	-	38	150	200	-	
220	FRN0520E2■-4□	150	-	38	150	200	-	
250	FRN0590E2■-4□	200	-	38	200	250	-	

The recommended wire sizes for the main circuit terminals assume using 75°C 600 V HIV wire.

*1 For compatible crimped terminals, please use model 8-L6 by JST Mfg. Co., Ltd. or equivalent.

*3 For compatible crimped terminals, please use model CB150-10 by JST Mfg. Co., Ltd. or equivalent.

Table 2.2-14 Recommended Wire Sizes, Ambient temperature: Below 40°C, Wire type: 75°C wire (continued)

HND Mode, Ambient temperature: Below 40°C, Wire type: 75°C wire

Power System	Std Applicable Motor (kW)	Inverter type	Recommended wire size (mm ²)					
			Main power supply input [L1/R, L2/S, L3/T]		Ground terminal [⊕G]	Inverter output [U, V, W]	For DC reactor connection [P1, P(+)]	For braking resistor connection [P(+), DB]
			With DC reactor	Without DC reactor				
Three-phase 200 V	0.2	FRN0001E2■-2□	2	2	2	2	2	2
	0.4	FRN0002E2■-2□	2	2	2	2	2	2
	0.75	FRN0004E2■-2□	2	2	2	2	2	2
	1.5	FRN0006E2■-2□	2	2	2	2	2	2
	2.2	FRN0010E2■-2□	2	2	2	2	2	2
	3.0	FRN0012E2■-2□ ^{*10}	2	2	2	2	2	2
	5.5	FRN0020E2■-2□ ^{*10}	2	3.5	3.5	2	2	2
	7.5	FRN0030E2■-2□	2	5.5	5.5	3.5	3.5	2
	11	FRN0040E2■-2□	5.5	8	5.5	5.5	5.5	2
	15	FRN0056E2■-2□	8	14	5.5	8	14	2
	18.5	FRN0069E2■-2□	14	22	8	14	14	2
	22	FRN0088E2■-2□	14	22	8	14	22	2
30	FRN0115E2■-2□	22	38 ^{*7}	14	22	38 ^{*7}	2	
Three-phase 400 V	0.75	FRN0002E2■-4□	2	2	2	2	2	2
	1.1	FRN0004E2■-4□	2	2	2	2	2	2
	2.2	FRN0006E2■-4□	2	2	2	2	2	2
	3.0	FRN0007E2■-4□ ^{*10}	2	2	2	2	2	2
	5.5	FRN0012E2■-4□ ^{*10}	2	2	2	2	2	2
	7.5	FRN0022E2■-4□	2	2	2	2	2	2
	11	FRN0029E2■-4□	2	3.5	3.5	2	2	2
	15	FRN0037E2■-4□	2	5.5	3.5	3.5	3.5	2
	18.5	FRN0044E2■-4□	5.5	8	5.5	5.5	5.5	2
	22	FRN0059E2■-4□	5.5	8 ^{*1}	5.5	5.5	5.5	2
	30	FRN0072E2■-4□	8 ^{*1}	14	8 ^{*1}	8 ^{*1}	14	2
	37	FRN0085E2■-4□	14	14	8	14	14	-
	45	FRN0105E2■-4□	14	22	8	14	22	-
	55	FRN0139E2■-4□	22	38	14	22	38	-
	75	FRN0168E2■-4□	38	-	14	38	38	-
	90	FRN0203E2■-4□	38	-	14	60	60	-
	110	FRN0240E2■-4□	60	-	22	60	100	-
	132	FRN0290E2■-4□	100	-	22	100	100	-
160	FRN0361E2■-4□	100	-	22	100	150	-	
200	FRN0415E2■-4□	150	-	38	150	200	-	
220	FRN0520E2■-4□	150	-	38	150	200	-	
280	FRN0590E2■-4□	200	-	38	250	325	-	

The recommended wire sizes for the main circuit terminals assume using 75°C 600V HIV wire.

*1 For compatible crimped terminals, please use model 8-L6 by JST Mfg. Co., Ltd. or equivalent.

*4 For compatible crimped terminals, please use model R5.5-6 by JST Mfg. Co., Ltd. or equivalent.

*7 For compatible crimped terminals, please use model 38-6 by JST Mfg. Co., Ltd. or equivalent.

*10 ND-spec.

Table 2.2-15 Recommended Wire Sizes, Ambient temperature: Below 40°C, Wire type: 75°C wire (continued)

HHD Mode, Ambient temperature: Below 40°C, Wire type: 75°C wire

Power System	Std Applicable Motor (kW)	Inverter type	Recommended wire size (mm ²)					
			Main power supply input [L1/R, L2/S, L3/T]		Ground terminal [⊕G]	Inverter output [U, V, W]	For DC reactor connection [P1, P(+)]	For braking resistor connection [P(+), DB]
			With DC reactor	Without DC reactor				
Three-phase 200 V	0.1	FRN0001E2-2□	2	2	2	2	2	2
	0.2	FRN0002E2-2□	2	2	2	2	2	2
	0.4	FRN0004E2-2□	2	2	2	2	2	2
	0.75	FRN0006E2-2□	2	2	2	2	2	2
	1.5	FRN0010E2-2□	2	2	2	2	2	2
	2.2	FRN0012E2-2□	2	2	2	2	2	2
	3.7	FRN0020E2-2□	2	2	2	2	2	2
	5.5	FRN0030E2-2□	2	3.5	3.5	2	2	2
	7.5	FRN0040E2-2□	2	5.5	5.5	3.5	3.5	2
	11	FRN0056E2-2□	5.5	8	5.5	5.5	5.5	2
	15	FRN0069E2-2□	8	14	5.5	8	14	2
	18.5	FRN0088E2-2□	14	22	8	14	14	2
22	FRN0115E2-2□	14	22	8	14	22	2	
Three-phase 400 V	0.4	FRN0002E2-4□	2	2	2	2	2	2
	0.75	FRN0004E2-4□	2	2	2	2	2	2
	1.5	FRN0006E2-4□	2	2	2	2	2	2
	2.2	FRN0007E2-4□	2	2	2	2	2	2
	3.7	FRN0012E2-4□	2	2	2	2	2	2
	5.5	FRN0022E2-4□	2	2	2	2	2	2
	7.5	FRN0029E2-4□	2	2	2	2	2	2
	11	FRN0037E2-4□	2	3.5	3.5	2	2	2
	15	FRN0044E2-4□	2	5.5	5.5	3.5	3.5	2
	18.5	FRN0059E2-4□	3.5 ^{*4}	8 ^{*1}	5.5	3.5 ^{*4}	5.5	2
	22	FRN0072E2-4□	5.5	8 ^{*1}	5.5	5.5	5.5	2
	30	FRN0085E2-4□	8	14	8	8	14	-
	37	FRN0105E2-4□	14	14	8	14	14	-
	45	FRN0139E2-4□	14	22	8	14	22	-
	55	FRN0168E2-4□	22	38	14	22	38	-
	75	FRN0203E2-4□	38	-	14	38	38	-
	90	FRN0240E2-4□	38	-	14	60	60	-
110	FRN0290E2-4□	60	-	22	60	100	-	
132	FRN0361E2-4□	100	-	22	100	100	-	
160	FRN0415E2-4□	100	-	22	100	150	-	
200	FRN0520E2-4□	150	-	38	150	200	-	
220	FRN0590E2-4□	150	-	38	150	200	-	
Single-phase 200 V	0.1	FRN0001E2-7□	2	2	2	2	2	2
	0.2	FRN0002E2-7□	2	2	2	2	2	2
	0.4	FRN0003E2-7□	2	2	2	2	2	2
	0.75	FRN0005E2-7□	2	2	2	2	2	2
	1.5	FRN0008E2-7□	2	2	2	2	2	2
	2.2	FRN0011E2-7□	2	2	2	2	2	2

The recommended wire sizes for the main circuit terminals assume using 75°C 600V HIV wire.

*1 For compatible crimped terminals, please use model 8-L6 by JST Mfg. Co., Ltd. or equivalent.

*4 For compatible crimped terminals, please use model R5.5-6 by JST Mfg. Co., Ltd. or equivalent.

3) Ambient temperature: Below 40°C, Wire type: 90°C wire

Table 2.2-16 Recommended Wire Sizes, Ambient temperature: Below 40°C, Wire type: 90°C wire

ND Mode, Ambient temperature: Below 40°C, Wire type: 90°C wire

Power System	Std Applicable Motor (kW)	Inverter type	Recommended wire size (mm ²)					
			Main power supply input [L1/R, L2/S, L3/T]		Ground terminal [⊕G]	Inverter output [U, V, W]	For DC reactor connection [P1, P(+)]	For braking resistor connection [P(+), DB]
			With DC reactor	Without DC reactor				
Three-phase 400 V	0.75	FRN0002E2■-4□	2	2	2	2	2	2
	1.5	FRN0004E2■-4□	2	2	2	2	2	2
	2.2	FRN0006E2■-4□	2	2	2	2	2	2
	3.0	FRN0007E2■-4□	2	2	2	2	2	2
	5.5	FRN0012E2■-4□	2	2	2	2	2	2
	11	FRN0022E2■-4□	2	2	3.5	2	2	2
	15	FRN0029E2■-4□	2	3.5	5.5	2	3.5	2
	18.5	FRN0037E2■-4□	3.5	5.5	5.5	3.5	3.5	2
	22	FRN0044E2■-4□	3.5	5.5	5.5	3.5	5.5	2
	30	FRN0059E2■-4□	5.5	8 ^{*1}	8 ^{*1}	5.5	8 ^{*1}	2
	37	FRN0072E2■-4□	8 ^{*1}	14	8 ^{*1}	8 ^{*1}	14	2
	45	FRN0085E2■-4□	14	22	8	14	14	-
	55	FRN0105E2■-4□	14	22	14	14	22	-
	75	FRN0139E2■-4□	22	-	14	22	38	-
	90	FRN0168E2■-4□	38	-	14	38	38	-
	110	FRN0203E2■-4□	38	-	22	38	60	-
	132	FRN0240E2■-4□	60	-	22	60	100	-
	160	FRN0290E2■-4□	100	-	22	100	100	-
200	FRN0361E2■-4□	100	-	38	100	150	-	
220	FRN0415E2■-4□	150	-	38	150	150	-	
280	FRN0520E2■-4□	150	-	38	200	250	-	
315	FRN0590E2■-4□	200	-	60	200	250	-	

HD Mode, Ambient temperature: Below 40°C, Wire type: 90°C wire

Power System	Std Applicable Motor (kW)	Inverter type	Recommended wire size (mm ²)					
			Main power supply input [L1/R, L2/S, L3/T]		Ground terminal [⊕G]	Inverter output [U, V, W]	For DC reactor connection [P1, P(+)]	For braking resistor connection [P(+), DB]
			With DC reactor	Without DC reactor				
Three-phase 400 V	0.75	FRN0002E2■-4□	2	2	2	2	2	2
	1.1	FRN0004E2■-4□	2	2	2	2	2	2
	2.2	FRN0006E2■-4□	2	2	2	2	2	2
	3.0	FRN0007E2■-4□	2	2	2	2	2	2
	5.5	FRN0012E2■-4□	2	2	2	2	2	2
	7.5	FRN0022E2■-4□	2	2	2	2	2	2
	11	FRN0029E2■-4□	2	2	3.5	2	2	2
	15	FRN0037E2■-4□	2	3.5	5.5	2	3.5	2
	18.5	FRN0044E2■-4□	3.5	5.5	5.5	3.5	3.5	2
	22	FRN0059E2■-4□	3.5 ^{*4}	5.5	5.5	3.5 ^{*4}	5.5	2
	30	FRN0072E2■-4□	5.5	8 ^{*1}	8 ^{*1}	5.5	8 ^{*1}	2
	37	FRN0085E2■-4□	8	14	8	8	14	-
	45	FRN0105E2■-4□	14	22	8	14	14	-
	55	FRN0139E2■-4□	14	22	14	14	22	-
	75	FRN0168E2■-4□	22	-	14	38	38	-
	90	FRN0203E2■-4□	38	-	14	38	38	-
	110	FRN0240E2■-4□	38	-	22	60	60	-
	132	FRN0290E2■-4□	60	-	22	60	100	-
160	FRN0361E2■-4□	100	-	22	100	100	-	
200	FRN0415E2■-4□	100	-	38	100	150	-	
220	FRN0520E2■-4□	150	-	38	150	150	-	
250	FRN0590E2■-4□	150	-	38	150	200	-	

The recommended wire sizes for the main circuit terminals assume using 90°C 600 V FSLC wire.

*1 For compatible crimped terminals, please use model 8-L6 by JST Mfg. Co., Ltd. or equivalent.

*4 For compatible crimped terminals, please use model R5.5-6 by JST Mfg. Co., Ltd. or equivalent.

Table 2.2-17 Recommended Wire Sizes, Ambient temperature: Below 40°C, Wire type: 90°C wire (continued)

HND Mode, Ambient temperature: Below 40°C, Wire type: 90°C wire

Power System	Std Applicable Motor (kW)	Inverter type	Recommended wire size (mm ²)					
			Main power supply input [L1/R, L2/S, L3/T]		Ground terminal [G]	Inverter output [U, V, W]	For DC reactor connection [P1, P(+)]	For braking resistor connection [P(+), DB]
			With DC reactor	Without DC reactor				
Three-phase 200 V	0.2	FRN0001E2-2□	2	2	2	2	2	2
	0.4	FRN0002E2-2□	2	2	2	2	2	2
	0.75	FRN0004E2-2□	2	2	2	2	2	2
	1.1	FRN0006E2-2□	2	2	2	2	2	2
	2.2	FRN0010E2-2□	2	2	2	2	2	2
	3.0	FRN0012E2-2□ ^{*10}	2	2	2	2	2	2
	5.5	FRN0020E2-2□ ^{*10}	2	2	3.5	2	2	2
	7.5	FRN0030E2-2□	2	3.5	5.5	2	3.5	2
	11	FRN0040E2-2□	3.5	5.5	5.5	3.5	5.5	2
	15	FRN0056E2-2□	5.5	14	5.5	5.5	8	2
	18.5	FRN0069E2-2□	8	14	8	8	14	2
	22	FRN0088E2-2□	14	14	8	14	14	2
30	FRN0115E2-2□	22	38 ^{*7}	14	22	22	2	
Three-phase 400 V	0.75	FRN0002E2-4□	2	2	2	2	2	2
	1.1	FRN0004E2-4□	2	2	2	2	2	2
	2.2	FRN0006E2-4□	2	2	2	2	2	2
	3.0	FRN0007E2-4□ ^{*10}	2	2	2	2	2	2
	5.5	FRN0012E2-4□ ^{*10}	2	2	2	2	2	2
	7.5	FRN0022E2-4□	2	2	2	2	2	2
	11	FRN0029E2-4□	2	2	3.5	2	2	2
	15	FRN0037E2-4□	2	3.5	3.5	3.5	3.5	2
	18.5	FRN0044E2-4□	3.5	5.5	5.5	3.5	3.5	2
	22	FRN0059E2-4□	3.5 ^{*4}	5.5	5.5	3.5 ^{*4}	5.5	2
	30	FRN0072E2-4□	5.5	8 ^{*1}	8 ^{*1}	5.5	8 ^{*1}	2
	37	FRN0085E2-4□	8	14	8	8	14	-
	45	FRN0105E2-4□	14	22	8	14	14	-
	55	FRN0139E2-4□	14	22	14	14	22	-
	75	FRN0168E2-4□	22	-	14	38	38	-
	90	FRN0203E2-4□	38	-	14	38	38	-
	110	FRN0240E2-4□	38	-	22	60	60	-
	132	FRN0290E2-4□	60	-	22	60	100	-
160	FRN0361E2-4□	100	-	22	100	100	-	
200	FRN0415E2-4□	100	-	38	100	150	-	
220	FRN0520E2-4□	150	-	38	150	150	-	
280	FRN0590E2-4□	150	-	38	200	250	-	

The recommended wire sizes for the main circuit terminals assume using 90°C 600 V FSLC wire.

*1 For compatible crimped terminals, please use model 8-L6 by JST Mfg. Co., Ltd. or equivalent.

*4 For compatible crimped terminals, please use model R5.5-6 by JST Mfg. Co., Ltd. or equivalent.

*7 For compatible crimped terminals, please use model 38-6 by JST Mfg. Co., Ltd. or equivalent.

*10 ND-spec.

Table 2.2-18 Recommended Wire Sizes, Ambient temperature: Below 40°C, Wire type: 90°C wire (continued)

HHD Mode, Ambient temperature: Below 40°C, Wire type: 90°C wire

Power System	Std Applicable Motor (kW)	Inverter type	Recommended wire size (mm ²)					
			Main power supply input [L1/R, L2/S, L3/T]		Ground terminal [G]	Inverter output [U, V, W]	For DC reactor connection [P1, P(+)]	For braking resistor connection [P(+), DB]
			With DC reactor	Without DC reactor				
Three-phase 200 V	0.1	FRN0001E2-2□	2	2	2	2	2	2
	0.2	FRN0002E2-2□	2	2	2	2	2	2
	0.4	FRN0004E2-2□	2	2	2	2	2	2
	0.75	FRN0006E2-2□	2	2	2	2	2	2
	1.5	FRN0010E2-2□	2	2	2	2	2	2
	2.2	FRN0012E2-2□	2	2	2	2	2	2
	3.7	FRN0020E2-2□	2	2	2	2	2	2
	5.5	FRN0030E2-2□	2	2	3.5	2	2	2
	7.5	FRN0040E2-2□	2	3.5	5.5	2	3.5	2
	11	FRN0056E2-2□	3.5	5.5	5.5	3.5	5.5	2
	15	FRN0069E2-2□	5.5	14	5.5	5.5	8	2
18.5	FRN0088E2-2□	8	14	8	8	14	2	
22	FRN0115E2-2□	14	14	8	14	14	2	
Three-phase 400 V	0.4	FRN0002E2-4□	2	2	2	2	2	2
	0.75	FRN0004E2-4□	2	2	2	2	2	2
	1.5	FRN0006E2-4□	2	2	2	2	2	2
	2.2	FRN0007E2-4□	2	2	2	2	2	2
	3.7	FRN0012E2-4□	2	2	2	2	2	2
	5.5	FRN0022E2-4□	2	2	2	2	2	2
	7.5	FRN0029E2-4□	2	2	2	2	2	2
	11	FRN0037E2-4□	2	2	3.5	2	2	2
	15	FRN0044E2-4□	2	3.5	5.5	2	3.5	2
	18.5	FRN0059E2-4□	3.5 ^{*4}	5.5	5.5	3.5 ^{*4}	3.5 ^{*4}	2
	22	FRN0072E2-4□	3.5 ^{*4}	5.5	5.5	3.5 ^{*4}	5.5	2
	30	FRN0085E2-4□	5.5	8	8	5.5	8	-
	37	FRN0105E2-4□	8	14	8	8	14	-
	45	FRN0139E2-4□	14	22	8	14	14	-
	55	FRN0168E2-4□	14	22	14	14	22	-
	75	FRN0203E2-4□	22	-	14	38	38	-
	90	FRN0240E2-4□	38	-	14	38	38	-
110	FRN0290E2-4□	38	-	22	60	60	-	
132	FRN0361E2-4□	60	-	22	60	100	-	
160	FRN0415E2-4□	100	-	22	100	100	-	
200	FRN0520E2-4□	100	-	38	100	150	-	
220	FRN0590E2-4□	150	-	38	150	150	-	
Single-phase 200 V	0.1	FRN0001E2-7□	2	2	2	2	2	2
	0.2	FRN0002E2-7□	2	2	2	2	2	2
	0.4	FRN0003E2-7□	2	2	2	2	2	2
	0.75	FRN0005E2-7□	2	2	2	2	2	2
	1.5	FRN0008E2-7□	2	2	2	2	2	2
	2.2	FRN0011E2-7□	2	2	2	2	2	2

The recommended wire sizes for the main circuit terminals assume using 90°C 600 V FSLC wire.

*1 For compatible crimped terminals, please use model 8-L6 by JST Mfg. Co., Ltd. or equivalent.

*4 For compatible crimped terminals, please use model R5.5-6 by JST Mfg. Co., Ltd. or equivalent.

4) Ambient temperature: Below 50°C, Wire type: 60°C wire

Table 2.2-19 Recommended Wire Sizes, Ambient temperature: Below 50°C, Wire type: 60°C wire

ND Mode, Ambient temperature: Below 50°C, Wire type: 60°C wire

Power System	Std Applicable Motor (kW)	Inverter type	Recommended wire size (mm ²)					
			Main power supply input (Note 1) [L1/R, L2/S, L3/T]		Ground terminal (Note 1) [⊕G]	Inverter output (Note 1) [U, V, W]	For DC reactor connection (Note 1) [P1, P(+)]	For braking resistor connection [P(+), DB]
			With DC reactor	Without DC reactor				
Three-phase 400 V	0.75	FRN0002E2■-4□	2	2	2	2	2	2
	1.5	FRN0004E2■-4□	2	2	2	2	2	2
	2.2	FRN0006E2■-4□	2	2	2	2	2	2
	3.0	FRN0007E2■-4□	2	2	2	2	2	2
	5.5	FRN0012E2■-4□	2	3.5	2	2	2	2
	11	FRN0022E2■-4□	3.5	5.5	3.5	3.5	3.5	2
	15	FRN0029E2■-4□	5.5	14	5.5	5.5	5.5	2
	18.5	FRN0037E2■-4□	8	14	5.5	8	5.5	2
	22	FRN0044E2■-4□	8	14	5.5	14	8	2
	30	FRN0059E2■-4□	14	22	8 ^{*1}	14	22	2
	37	FRN0072E2■-4□	22	38	8 ^{*1}	22	38	2
	45	FRN0085E2■-4□	38	38	8	38	38	-
	55	FRN0105E2■-4□	38	60	14	38	60	-
	75	FRN0139E2■-4□	60	-	14	60	100 ^{*2}	-
	90	FRN0168E2■-4□	100 ^{*2}	-	14	100 ^{*2}	100 ^{*2}	-
	110	FRN0203E2■-4□	100	-	22	100	-	-
	132	FRN0240E2■-4□	-	-	22	-	-	-
	160	FRN0290E2■-4□	-	-	22	-	-	-
200	FRN0361E2■-4□	-	-	38	-	-	-	
220	FRN0415E2■-4□	-	-	38	-	-	-	
280	FRN0520E2■-4□	-	-	38	-	-	-	
315	FRN0590E2■-4□	-	-	60	-	-	-	

HD Mode, Ambient temperature: Below 50°C, Wire type: 60°C wire

Power System	Std Applicable Motor (kW)	Inverter type	Recommended wire size (mm ²)					
			Main power supply input (Note 1) [L1/R, L2/S, L3/T]		Ground terminal (Note 1) [⊕G]	Inverter output (Note 1) [U, V, W]	For DC reactor connection (Note 1) * [P1, P(+)]	For braking resistor connection [P(+), DB]
			With DC reactor	Without DC reactor				
Three-phase 400 V	0.75	FRN0002E2■-4□	2	2	2	2	2	2
	1.1	FRN0004E2■-4□	2	2	2	2	2	2
	2.2	FRN0006E2■-4□	2	2	2	2	2	2
	3.0	FRN0007E2■-4□	2	2	2	2	2	2
	5.5	FRN0012E2■-4□	2	3.5	2	2	2	2
	7.5	FRN0022E2■-4□	2	3.5	2	2	2	2
	11	FRN0029E2■-4□	3.5	5.5	3.5	3.5	3.5	2
	15	FRN0037E2■-4□	5.5	14	5.5	5.5	5.5	2
	18.5	FRN0044E2■-4□	8	14	5.5	8	5.5	2
	22	FRN0059E2■-4□	8 ^{*1}	14	5.5	14	14	2
	30	FRN0072E2■-4□	14	22	8 ^{*1}	14	22	2
	37	FRN0085E2■-4□	22	38	8	22	38	-
	45	FRN0105E2■-4□	38	38	8	38	38	-
	55	FRN0139E2■-4□	38	60	14	38	60	-
	75	FRN0168E2■-4□	60	-	14	60	100 ^{*2}	-
	90	FRN0203E2■-4□	100	-	14	100	100	-
	110	FRN0240E2■-4□	100	-	22	100	-	-
	132	FRN0290E2■-4□	-	-	22	-	-	-
160	FRN0361E2■-4□	-	-	22	-	-	-	
200	FRN0415E2■-4□	-	-	38	-	-	-	
220	FRN0520E2■-4□	-	-	38	-	-	-	
250	FRN0590E2■-4□	-	-	38	-	-	-	

Note 1) The rated current must be reduced for operation (Rated current x 80%). Recommended wire sizes assume these conditions.

The recommended wire sizes for the main circuit terminals assume using 60°C IV wire.

*1 For compatible crimped terminals, please use model 8-L6 by JST Mfg. Co., Ltd. or equivalent.

*2 For compatible crimped terminals, please use model CB100-S8 by JST Mfg. Co., Ltd. or equivalent.

Table 2.2-20 Recommended Wire Sizes, Ambient temperature: Below 50°C, Wire type: 60°C wire (continued)

HND Mode, Ambient temperature: Below 50°C, Wire type: 60°C wire

Power System	Std Applicable Motor (kW)	Inverter type	Recommended wire size (mm ²)					
			Main power supply input [L1/R, L2/S, L3/T]		Ground terminal [G]	Inverter output [U, V, W]	For DC reactor connection [P1, P(+)]	For braking resistor connection [P(+), DB]
			With DC reactor	Without DC reactor				
Three-phase 200 V	0.2	FRN0001E2■-2□	2	2	2	2	2	2
	0.4	FRN0002E2■-2□	2	2	2	2	2	2
	0.75	FRN0004E2■-2□	2	2	2	2	2	2
	1.1	FRN0006E2■-2□	2	2	2	2	2	2
	2.2	FRN0010E2■-2□	2	2	2	2	2	2
	3.0	FRN0012E2■-2□ ^{*10}	2	3.5	2	2	2	2
	5.5	FRN0020E2■-2□ ^{*10}	3.5	8	3.5	3.5	5.5	2
	7.5	FRN0030E2■-2□	8	14	5.5	8	14	2
	11	FRN0040E2■-2□	14	22 ³	5.5	14	22 ³	2
	15	FRN0056E2■-2□	22	38 ⁴	5.5	22	38 ⁴	2
	18.5	FRN0069E2■-2□	38 ⁴	60 ⁵	8	38 ⁴	38 ⁴	2
	22	FRN0088E2■-2□	38 ⁷	60 ⁸	8	38 ⁷	60 ⁸	2
30	FRN0115E2■-2□	60 ⁸	100 ⁹	14	60 ⁸	100 ⁹	2	
Three-phase 400 V	0.75	FRN0002E2■-4□	2	2	2	2	2	2
	1.1	FRN0004E2■-4□	2	2	2	2	2	2
	2.2	FRN0006E2■-4□	2	2	2	2	2	2
	3.0	FRN0007E2■-4□ ^{*10}	2	2	2	2	2	2
	5.5	FRN0012E2■-4□ ^{*10}	2	3.5	2	2	2	2
	7.5	FRN0022E2■-4□	2	5.5	2	3.5	3.5	2
	11	FRN0029E2■-4□	5.5	8	3.5	5.5	5.5	2
	15	FRN0037E2■-4□	8	14	3.5	8	14	2
	18.5	FRN0044E2■-4□	14	22	5.5	14	14	2
	22	FRN0059E2■-4□	14	22	5.5	14	22	2
	30	FRN0072E2■-4□	22	38	8 ¹	22	38	2
	37	FRN0085E2■-4□	38	60	8	38	38	-
	45	FRN0105E2■-4□	38	60	8	38	60	-
	55	FRN0139E2■-4□	60	100 ²	14	60	60	-
	75	FRN0168E2■-4□	100 ²	-	14	100 ²	100 ²	-
	90	FRN0203E2■-4□	100	-	14	-	-	-
	110	FRN0240E2■-4□	-	-	22	-	-	-
	132	FRN0290E2■-4□	-	-	22	-	-	-
160	FRN0361E2■-4□	-	-	22	-	-	-	
200	FRN0415E2■-4□	-	-	38	-	-	-	
220	FRN0520E2■-4□	-	-	38	-	-	-	
280	FRN0590E2■-4□	-	-	38	-	-	-	

The recommended wire sizes for the main circuit terminals assume using 60°C IV wire.

- *1 For compatible crimped terminals, please use model 8-L6 by JST Mfg. Co., Ltd. or equivalent.
- *2 For compatible crimped terminals, please use model CB100-S8 by JST Mfg. Co., Ltd. or equivalent.
- *3 For compatible crimped terminals, please use model 22-S5 by JST Mfg. Co., Ltd. or equivalent.
- *4 For compatible crimped terminals, please use model 38-S6 by JST Mfg. Co., Ltd. or equivalent.
- *5 For compatible crimped terminals, please use model CB60-S6 by JST Mfg. Co., Ltd. or equivalent.
- *7 For compatible crimped terminals, please use model 38-6 by JST Mfg. Co., Ltd. or equivalent.
- *8 For compatible crimped terminals, please use model 60-6 by JST Mfg. Co., Ltd. or equivalent.
- *9 For compatible crimped terminals, please use model CB100-S8 by JST Mfg. Co., Ltd. or equivalent.
- *10 ND-spec.

Table 2.2-21 Recommended Wire Sizes, Ambient temperature: Below 50°C, Wire type: 60°C wire (continued)

HHD Mode, Ambient temperature: Below 50°C, Wire type: 60°C wire

Power System	Std Applicable Motor (kW)	Inverter type	Recommended wire size (mm ²)					
			Main power supply input [L1/R, L2/S, L3/T]		Ground terminal [G]	Inverter output [U, V, W]	For DC reactor connection [P1, P(+)]	For braking resistor connection [P(+), DB]
			With DC reactor	Without DC reactor				
Three-phase 200 V	0.1	FRN0001E2■-2□	2	2	2	2	2	2
	0.2	FRN0002E2■-2□	2	2	2	2	2	2
	0.4	FRN0004E2■-2□	2	2	2	2	2	2
	0.75	FRN0006E2■-2□	2	2	2	2	2	2
	1.5	FRN0010E2■-2□	2	2	2	2	2	2
	2.2	FRN0012E2■-2□	2	2	2	2	2	2
	3.7	FRN0020E2■-2□	2	5.5	2	3.5	3.5	2
	5.5	FRN0030E2■-2□	5.5	8	3.5	5.5	5.5	2
	7.5	FRN0040E2■-2□	8	14	5.5	8	14	2
	11	FRN0056E2■-2□	14	22	5.5	14	22	2
	15	FRN0069E2■-2□	22	38	5.5	22	38	2
	18.5	FRN0088E2■-2□	38 ^{*7}	60 ^{*8}	8	38 ^{*7}	38 ^{*7}	2
22	FRN0115E2■-2□	38 ^{*7}	60 ^{*8}	8	38 ^{*7}	60 ^{*8}	2	
Three-phase 400 V	0.4	FRN0002E2■-4□	2	2	2	2	2	2
	0.75	FRN0004E2■-4□	2	2	2	2	2	2
	1.5	FRN0006E2■-4□	2	2	2	2	2	2
	2.2	FRN0007E2■-4□	2	2	2	2	2	2
	3.7	FRN0012E2■-4□	2	2	2	2	2	2
	5.5	FRN0022E2■-4□	2	3.5	2	2	2	2
	7.5	FRN0029E2■-4□	2	5.5	2	3.5	3.5	2
	11	FRN0037E2■-4□	5.5	8	3.5	5.5	5.5	2
	15	FRN0044E2■-4□	8	14	5.5	8	14	2
	18.5	FRN0059E2■-4□	14	22	5.5	14	14	2
	22	FRN0072E2■-4□	14	22	5.5	14	22	2
	30	FRN0085E2■-4□	22	38	8	22	38	-
	37	FRN0105E2■-4□	38	60	8	38	38	-
	45	FRN0139E2■-4□	38	60	8	38	60	-
	55	FRN0168E2■-4□	60	100 ^{*2}	14	60	60	-
	75	FRN0203E2■-4□	100	-	14	100	100	-
	90	FRN0240E2■-4□	100	-	14	-	-	-
110	FRN0290E2■-4□	-	-	22	-	-	-	
132	FRN0361E2■-4□	-	-	22	-	-	-	
160	FRN0415E2■-4□	-	-	22	-	-	-	
200	FRN0520E2■-4□	-	-	38	-	-	-	
220	FRN0590E2■-4□	-	-	38	-	-	-	
Single-phase 200 V	0.1	FRN0001E2■-7□	2	2	2	2	2	2
	0.2	FRN0002E2■-7□	2	2	2	2	2	2
	0.4	FRN0003E2■-7□	2	2	2	2	2	2
	0.75	FRN0005E2■-7□	2	2	2	2	2	2
	1.5	FRN0008E2■-7□	2	3.5	2	2	2	2
	2.2	FRN0011E2■-7□	3.5	5.5	2	2	3.5	2

The recommended wire sizes for the main circuit terminals assume using 60°C IV wire.

- *1 For compatible crimped terminals, please use model 8-L6 by JST Mfg. Co., Ltd. or equivalent.
- *2 For compatible crimped terminals, please use model CB100-S8 by JST Mfg. Co., Ltd. or equivalent.
- *3 For compatible crimped terminals, please use model 22-S5 by JST Mfg. Co., Ltd. or equivalent.
- *4 For compatible crimped terminals, please use model 38-S6 by JST Mfg. Co., Ltd. or equivalent.
- *5 For compatible crimped terminals, please use model CB60-S6 by JST Mfg. Co., Ltd. or equivalent.
- *7 For compatible crimped terminals, please use model 38-6 by JST Mfg. Co., Ltd. or equivalent.
- *8 For compatible crimped terminals, please use model 60-6 by JST Mfg. Co., Ltd. or equivalent.

5) Ambient temperature: Below 50°C, Wire type: 75°C wire

Table 2.2-22 Recommended Wire Sizes, Ambient temperature: Below 50°C, Wire type: 75°C wire

ND Mode, Ambient temperature: Below 50°C, Wire type: 75°C wire

Power System	Std Applicable Motor (kW)	Inverter type	Recommended wire size (mm ²)					
			Main power supply input (Note 1) [L1/R, L2/S, L3/T]		Ground terminal (Note 1) [G]	Inverter output (Note 1) [U, V, W]	For DC reactor connection (Note 1) [P1, P(+)]	For braking resistor connection [P(+), DB]
			With DC reactor	Without DC reactor				
Three-phase 400 V	0.75	FRN0002E2■-4□	2	2	2	2	2	2
	1.5	FRN0004E2■-4□	2	2	2	2	2	2
	2.2	FRN0006E2■-4□	2	2	2	2	2	2
	3.0	FRN0007E2■-4□	2	2	2	2	2	2
	5.5	FRN0012E2■-4□	2	2	2	2	2	2
	11	FRN0022E2■-4□	2	3.5	3.5	2	2	2
	15	FRN0029E2■-4□	2	5.5	5.5	2	2	2
	18.5	FRN0037E2■-4□	3.5	5.5	5.5	3.5	3.5	2
	22	FRN0044E2■-4□	5.5	8	5.5	5.5	5.5	2
	30	FRN0059E2■-4□	8 ^{*1}	14	8 ^{*1}	8 ^{*1}	14	2
	37	FRN0072E2■-4□	8 ^{*1}	14	8 ^{*1}	14	14	2
	45	FRN0085E2■-4□	14	22	8	14	22	-
	55	FRN0105E2■-4□	22	38	14	22	22	-
	75	FRN0139E2■-4□	38	-	14	38	38	-
	90	FRN0168E2■-4□	38	-	14	38	60	-
	110	FRN0203E2■-4□	60	-	22	60	60	-
	132	FRN0240E2■-4□	60	-	22	60	100	-
	160	FRN0290E2■-4□	100	-	22	100	150 ^{*3}	-
200	FRN0361E2■-4□	150	-	38	150	150	-	
220	FRN0415E2■-4□	150	-	38	150	200	-	
280	FRN0520E2■-4□	200	-	38	200	250	-	
315	FRN0590E2■-4□	250	-	60	250	325	-	

HD Mode, Ambient temperature: Below 50°C, Wire type: 75°C wire

Power System	Std Applicable Motor (kW)	Inverter type	Recommended wire size (mm ²)					
			Main power supply input (Note 1) [L1/R, L2/S, L3/T]		Ground terminal (Note 1) [G]	Inverter output (Note 1) [U, V, W]	For DC reactor connection (Note 1) [P1, P(+)]	For braking resistor connection [P(+), DB]
			With DC reactor	Without DC reactor				
Three-phase 400 V	0.75	FRN0002E2■-4□	2	2	2	2	2	2
	1.1	FRN0004E2■-4□	2	2	2	2	2	2
	2.2	FRN0006E2■-4□	2	2	2	2	2	2
	3.0	FRN0007E2■-4□	2	2	2	2	2	2
	5.5	FRN0012E2■-4□	2	2	2	2	2	2
	7.5	FRN0022E2■-4□	2	2	2	2	2	2
	11	FRN0029E2■-4□	2	3.5	3.5	2	2	2
	15	FRN0037E2■-4□	2	5.5	5.5	3.5	2	2
	18.5	FRN0044E2■-4□	3.5	5.5	5.5	3.5	3.5	2
	22	FRN0059E2■-4□	5.5	8 ^{*1}	5.5	5.5	5.5	2
	30	FRN0072E2■-4□	8 ^{*1}	14	8 ^{*1}	8 ^{*1}	14	2
	37	FRN0085E2■-4□	8	14	8	14	14	-
	45	FRN0105E2■-4□	14	22	8	14	22	-
	55	FRN0139E2■-4□	22	38	14	22	22	-
	75	FRN0168E2■-4□	38	-	14	38	38	-
	90	FRN0203E2■-4□	38	-	14	38	60	-
	110	FRN0240E2■-4□	60	-	22	60	60	-
	132	FRN0290E2■-4□	60	-	22	100	100	-
160	FRN0361E2■-4□	100	-	22	100	150	-	
200	FRN0415E2■-4□	150	-	38	150	150	-	
220	FRN0520E2■-4□	150	-	38	150	200	-	
250	FRN0590E2■-4□	150	-	38	200	250	-	

Note 1) The rated current must be reduced for operation (Rated current x 80%). Recommended wire sizes assume these conditions.

The recommended wire sizes for the main circuit terminals assume using 75°C 600 V HIV wire.

*1 For compatible crimped terminals, please use model 8-L6 by JST Mfg. Co., Ltd. or equivalent.

*3 For compatible crimped terminals, please use model CB150-10 by JST Mfg. Co., Ltd. or equivalent.

Table 2.2-23 Recommended Wire Sizes, Ambient temperature: Below 50°C, Wire type: 75°C wire (continued)

HND Mode, Ambient temperature: Below 50°C, Wire type: 75°C wire

Power System	Std Applicable Motor (kW)	Inverter type	Recommended wire size (mm ²)					
			Main power supply input [L1/R, L2/S, L3/T]		Ground terminal [G]	Inverter output [U, V, W]	For DC reactor connection [P1, P(+)]	For braking resistor connection [P(+), DB]
			With DC reactor	Without DC reactor				
Three-phase 200 V	0.2	FRN0001E2■-2□	2	2	2	2	2	2
	0.4	FRN0002E2■-2□	2	2	2	2	2	2
	0.75	FRN0004E2■-2□	2	2	2	2	2	2
	1.1	FRN0006E2■-2□	2	2	2	2	2	2
	2.2	FRN0010E2■-2□	2	2	2	2	2	2
	3.0	FRN0012E2■-2□ ^{*10}	2	2	2	2	2	2
	5.5	FRN0020E2■-2□ ^{*10}	2	3.5	3.5	2	3.5	2
	7.5	FRN0030E2■-2□	3.5	5.5	5.5	3.5	5.5	2
	11	FRN0040E2■-2□	5.5	14	5.5	5.5	8	2
	15	FRN0056E2■-2□	14	14	5.5	14	14	2
	18.5	FRN0069E2■-2□	14	22	8	14	22	2
	22	FRN0088E2■-2□	22	38 ^{*7}	8	22	22	2
30	FRN0115E2■-2□	38 ^{*7}	60 ^{*8}	14	38 ^{*7}	38 ^{*7}	2	
Three-phase 400 V	0.75	FRN0002E2■-4□	2	2	2	2	2	2
	1.1	FRN0004E2■-4□	2	2	2	2	2	2
	2.2	FRN0006E2■-4□	2	2	2	2	2	2
	3.0	FRN0007E2■-4□ ^{*10}	2	2	2	2	2	2
	5.5	FRN0012E2■-4□ ^{*10}	2	2	2	2	2	2
	7.5	FRN0022E2■-4□	2	2	2	2	2	2
	11	FRN0029E2■-4□	2	3.5	3.5	2	3.5	2
	15	FRN0037E2■-4□	3.5	5.5	3.5	5.5	5.5	2
	18.5	FRN0044E2■-4□	5.5	8	5.5	5.5	5.5	2
	22	FRN0059E2■-4□	5.5	14	5.5	8 ^{*1}	8 ^{*1}	2
	30	FRN0072E2■-4□	14	14	8 ^{*1}	14	14	2
	37	FRN0085E2■-4□	14	22	8	14	22	-
	45	FRN0105E2■-4□	22	38	8	22	22	-
	55	FRN0139E2■-4□	22	38	14	38	38	-
	75	FRN0168E2■-4□	38	-	14	60	60	-
	90	FRN0203E2■-4□	60	-	14	60	100	-
	110	FRN0240E2■-4□	100	-	22	100	100	-
	132	FRN0290E2■-4□	100	-	22	100	150 ^{*3}	-
160	FRN0361E2■-4□	150	-	22	150	150	-	
200	FRN0415E2■-4□	150	-	38	200	250	-	
220	FRN0520E2■-4□	200	-	38	200	250	-	
280	FRN0590E2■-4□	250	-	38	325	200×2	-	

Note 1) The rated current must be reduced for operation (Rated current x 80%). Recommended wire sizes assume these conditions.

The recommended wire sizes for the main circuit terminals assume using 75°C 600 V HIV wire.

- *1 For compatible crimped terminals, please use model 8-L6 by JST Mfg. Co., Ltd. or equivalent.
- *3 For compatible crimped terminals, please use model CB150-10 by JST Mfg. Co., Ltd. or equivalent.
- *7 For compatible crimped terminals, please use model 38-6 by JST Mfg. Co., Ltd. or equivalent.
- *8 For compatible crimped terminals, please use model 60-6 by JST Mfg. Co., Ltd. or equivalent.
- *10 ND-spec.

Table 2.2-24 Recommended Wire Sizes, Ambient temperature: Below 50°C, Wire type: 75°C wire (continued)

HHD Mode, Ambient temperature: Below 50°C, Wire type: 75°C wire

Power System	Std Applicable Motor (kW)	Inverter type	Recommended wire size (mm ²)					
			Main power supply input [L1/R, L2/S, L3/T]		Ground terminal [G]	Inverter output [U, V, W]	For DC reactor connection [P1, P(+)]	For braking resistor connection [P(+), DB]
			With DC reactor	Without DC reactor				
Three-phase 200 V	0.1	FRN0001E2■-2□	2	2	2	2	2	2
	0.2	FRN0002E2■-2□	2	2	2	2	2	2
	0.4	FRN0004E2■-2□	2	2	2	2	2	2
	0.75	FRN0006E2■-2□	2	2	2	2	2	2
	1.5	FRN0010E2■-2□	2	2	2	2	2	2
	2.2	FRN0012E2■-2□	2	2	2	2	2	2
	3.7	FRN0020E2■-2□	2	2	2	2	2	2
	5.5	FRN0030E2■-2□	2	3.5	3.5	3.5	3.5	2
	7.5	FRN0040E2■-2□	3.5	5.5	5.5	3.5	5.5	2
	11	FRN0056E2■-2□	5.5	14	5.5	8	8	2
	15	FRN0069E2■-2□	14	14	5.5	14	14	2
Three-phase 400 V	0.4	FRN0002E2■-4□	2	2	2	2	2	2
	0.75	FRN0004E2■-4□	2	2	2	2	2	2
	1.5	FRN0006E2■-4□	2	2	2	2	2	2
	2.2	FRN0007E2■-4□	2	2	2	2	2	2
	3.7	FRN0012E2■-4□	2	2	2	2	2	2
	5.5	FRN0022E2■-4□	2	2	2	2	2	2
	7.5	FRN0029E2■-4□	2	2	2	2	2	2
	11	FRN0037E2■-4□	2	3.5	3.5	2	3.5	2
	15	FRN0044E2■-4□	3.5	5.5	5.5	3.5	5.5	2
	18.5	FRN0059E2■-4□	5.5	8 ^{*1}	5.5	5.5	5.5	2
	22	FRN0072E2■-4□	5.5	14	5.5	8 ^{*1}	8 ^{*1}	2
	30	FRN0085E2■-4□	14	14	8	14	14	-
	37	FRN0105E2■-4□	14	22	8	14	22	-
	45	FRN0139E2■-4□	22	38	8	22	22	-
	55	FRN0168E2■-4□	22	38	14	38	38	-
	75	FRN0203E2■-4□	38	-	14	60	60	-
	90	FRN0240E2■-4□	60	-	14	60	100	-
	110	FRN0290E2■-4□	100	-	22	100	100	-
	132	FRN0361E2■-4□	100	-	22	100	150	-
160	FRN0415E2■-4□	150	-	22	150	150	-	
200	FRN0520E2■-4□	150	-	38	200	250	-	
220	FRN0590E2■-4□	200	-	38	200	250	-	
Single-phase 200 V	0.1	FRN0001E2■-7□	2	2	2	2	2	2
	0.2	FRN0002E2■-7□	2	2	2	2	2	2
	0.4	FRN0003E2■-7□	2	2	2	2	2	2
	0.75	FRN0005E2■-7□	2	2	2	2	2	2
	1.5	FRN0008E2■-7□	2	2	2	2	2	2
	2.2	FRN0011E2■-7□	2	3.5	2	2	2	2

The recommended wire sizes for the main circuit terminals assume using 75°C 600 V HIV wire.

- *1 For compatible crimped terminals, please use model 8-L6 by JST Mfg. Co., Ltd. or equivalent.
- *3 For compatible crimped terminals, please use model CB150-10 by JST Mfg. Co., Ltd. or equivalent.
- *7 For compatible crimped terminals, please use model 38-6 by JST Mfg. Co., Ltd. or equivalent.

6) Ambient temperature: Below 50°C, Wire type: 90°C wire

Table 2.2-25 Recommended Wire Sizes, Ambient temperature: Below 50°C, Wire type: 90°C wire

ND Mode, Ambient temperature: Below 50°C, Wire type: 90°C wire

Power System	Std Applicable Motor (kW)	Inverter type	Recommended wire size (mm ²)					
			Main power supply input (Note 1) [L1/R, L2/S, L3/T]		Ground terminal (Note 1) [⊕G]	Inverter output (Note 1) [U, V, W]	For DC reactor connection (Note 1) [P1, P(+)]	For braking resistor connection [P(+), DB]
			With DC reactor	Without DC reactor				
Three-phase 400 V	0.75	FRN0002E2■-4□	2	2	2	2	2	2
	1.5	FRN0004E2■-4□	2	2	2	2	2	2
	2.2	FRN0006E2■-4□	2	2	2	2	2	2
	3.0	FRN0007E2■-4□	2	2	2	2	2	2
	5.5	FRN0012E2■-4□	2	2	2	2	2	2
	11	FRN0022E2■-4□	2	3.5	3.5	2	2	2
	15	FRN0029E2■-4□	2	5.5	5.5	2	3.5	2
	18.5	FRN0037E2■-4□	3.5	5.5	5.5	3.5	5.5	2
	22	FRN0044E2■-4□	5.5	8	5.5	5.5	5.5	2
	30	FRN0059E2■-4□	5.5	8 ^{*1}	8 ^{*1}	5.5	5.5	2
	37	FRN0072E2■-4□	5.5	14	8 ^{*1}	8 ^{*1}	8 ^{*1}	2
	45	FRN0085E2■-4□	8	14	8	8	14	-
	55	FRN0105E2■-4□	14	22	14	14	14	-
	75	FRN0139E2■-4□	22	-	14	22	38	-
	90	FRN0168E2■-4□	22	-	14	38	38	-
	110	FRN0203E2■-4□	38	-	22	38	60	-
	132	FRN0240E2■-4□	60	-	22	60	60	-
	160	FRN0290E2■-4□	60	-	22	60	100	-
	200	FRN0361E2■-4□	100	-	38	100	150	-
220	FRN0415E2■-4□	100	-	38	100	150	-	
280	FRN0520E2■-4□	150	-	38	150	200	-	
315	FRN0590E2■-4□	150	-	60	200	250	-	

Note 1) The rated current must be reduced for operation (Rated current x 80%). Recommended wire sizes assume these conditions.

HD Mode, Ambient temperature: Below 50°C, Wire type: 90°C wire

Power System	Std Applicable Motor (kW)	Inverter type	Recommended wire size (mm ²)					
			Main power supply input (Note 1) [L1/R, L2/S, L3/T]		Ground terminal (Note 1) [⊕G]	Inverter output (Note 1) [U, V, W]	For DC reactor connection (Note 1) [P1, P(+)]	For braking resistor connection [P(+), DB]
			With DC reactor	Without DC reactor				
Three-phase 400 V	0.75	FRN0002E2■-4□	2	2	2	2	2	2
	1.1	FRN0004E2■-4□	2	2	2	2	2	2
	2.2	FRN0006E2■-4□	2	2	2	2	2	2
	3.0	FRN0007E2■-4□	2	2	2	2	2	2
	5.5	FRN0012E2■-4□	2	2	2	2	2	2
	7.5	FRN0022E2■-4□	2	2	2	2	2	2
	11	FRN0029E2■-4□	2	3.5	3.5	2	2	2
	15	FRN0037E2■-4□	2	5.5	5.5	2	3.5	2
	18.5	FRN0044E2■-4□	3.5	5.5	5.5	3.5	5.5	2
	22	FRN0059E2■-4□	3.5 ^{*4}	5.5	5.5	3.5 ^{*4}	3.5 ^{*4}	2
	30	FRN0072E2■-4□	5.5	8 ^{*1}	8 ^{*1}	5.5	5.5	2
	37	FRN0085E2■-4□	5.5	14	8	8	8	-
	45	FRN0105E2■-4□	8	14	8	14	14	-
	55	FRN0139E2■-4□	14	22	14	14	14	-
	75	FRN0168E2■-4□	22	-	14	22	38	-
	90	FRN0203E2■-4□	22	-	14	38	38	-
	110	FRN0240E2■-4□	38	-	22	38	60	-
	132	FRN0290E2■-4□	60	-	22	60	60	-
	160	FRN0361E2■-4□	60	-	22	60	100	-
200	FRN0415E2■-4□	100	-	38	100	150	-	
220	FRN0520E2■-4□	100	-	38	100	150	-	
250	FRN0590E2■-4□	150	-	38	150	150	-	

Note 1) The rated current must be reduced for operation (Rated current x 80%). Recommended wire sizes assume these conditions.

The recommended wire sizes for the main circuit terminals assume using 90°C 600 V FSLC wire.

*1 For compatible crimped terminals, please use model 8-L6 by JST Mfg. Co., Ltd. or equivalent.

*4 For compatible crimped terminals, please use model R5.5-6 by JST Mfg. Co., Ltd. or equivalent.

Table 2.2-26 Recommended Wire Sizes, Ambient temperature: Below 50°C, Wire type: 90°C wire (continued)

HND Mode, Ambient temperature: Below 50°C, Wire type: 90°C wire

Power System	Std Applicable Motor (kW)	Inverter type	Recommended wire size (mm ²)					
			Main power supply input [L1/R, L2/S, L3/T]		Ground terminal [G]	Inverter output [U, V, W]	For DC reactor connection [P1, P(+)]	For braking resistor connection [P(+), DB]
			With DC reactor	Without DC reactor				
Three-phase 200 V	0.2	FRN0001E2■-2□	2	2	2	2	2	2
	0.4	FRN0002E2■-2□	2	2	2	2	2	2
	0.75	FRN0004E2■-2□	2	2	2	2	2	2
	1.1	FRN0006E2■-2□	2	2	2	2	2	2
	2.2	FRN0010E2■-2□	2	2	2	2	2	2
	3.0	FRN0012E2■-2□ ^{*10}	2	2	2	2	2	2
	5.5	FRN0020E2■-2□ ^{*10}	2	3.5	3.5	2	2	2
	7.5	FRN0030E2■-2□	2	5.5	5.5	2	3.5	2
	11	FRN0040E2■-2□	5.5	8	5.5	3.5	5.5	2
	15	FRN0056E2■-2□	8	14	5.5	5.5	14	2
	18.5	FRN0069E2■-2□	14	14	8	8	14	2
	22	FRN0088E2■-2□	14	22	8	14	22	2
30	FRN0115E2■-2□	22	38 ^{*7}	14	22	38 ^{*7}	2	
Three-phase 400 V	0.75	FRN0002E2■-4□	2	2	2	2	2	2
	1.1	FRN0004E2■-4□	2	2	2	2	2	2
	2.2	FRN0006E2■-4□	2	2	2	2	2	2
	3.0	FRN0007E2■-4□ ^{*10}	2	2	2	2	2	2
	5.5	FRN0012E2■-4□ ^{*10}	2	2	2	2	2	2
	7.5	FRN0022E2■-4□	2	2	2	2	2	2
	11	FRN0029E2■-4□	2	3.5	3.5	2	2	2
	15	FRN0037E2■-4□	2	5.5	3.5	3.5	3.5	2
	18.5	FRN0044E2■-4□	3.5	5.5	5.5	3.5	5.5	2
	22	FRN0059E2■-4□	5.5	8 ^{*1}	5.5	5.5	5.5	2
	30	FRN0072E2■-4□	8 ^{*1}	14	8 ^{*1}	8 ^{*1}	8 ^{*1}	2
	37	FRN0085E2■-4□	8	14	8	14	14	-
	45	FRN0105E2■-4□	14	22	8	14	22	-
	55	FRN0139E2■-4□	22	38	14	22	22	-
	75	FRN0168E2■-4□	38	-	14	38	38	-
	90	FRN0203E2■-4□	38	-	14	38	60	-
	110	FRN0240E2■-4□	60	-	22	60	60	-
	132	FRN0290E2■-4□	60	-	22	100	100	-
160	FRN0361E2■-4□	100	-	22	100	150	-	
200	FRN0415E2■-4□	150	-	38	150	150	-	
220	FRN0520E2■-4□	150	-	38	150	200	-	
280	FRN0590E2■-4□	200	-	38	200	250	-	

The recommended wire sizes for the main circuit terminals assume using 90°C 600 V FSLC wire.

*1 For compatible crimped terminals, please use model 8-L6 by JST Mfg. Co., Ltd. or equivalent.

*4 For compatible crimped terminals, please use model R5.5-6 by JST Mfg. Co., Ltd. or equivalent.

*7 For compatible crimped terminals, please use model 38-6 by JST Mfg. Co., Ltd. or equivalent.

*10 ND-spec

Table 2.2-27 Recommended Wire Sizes, Ambient temperature: Below 50°C, Wire type: 90°C wire (continued)

HHD Mode, Ambient temperature: Below 50°C, Wire type: 90°C wire

Power System	Std Applicable Motor (kW)	Inverter type	Recommended wire size (mm ²)					
			Main power supply input [L1/R, L2/S, L3/T]		Ground terminal [⊕G]	Inverter output [U, V, W]	For DC reactor connection [P1, P(+)]	For braking resistor connection [P(+), DB]
			With DC reactor	Without DC reactor				
Three-phase 200 V	0.1	FRN0001E2■-2□	2	2	2	2	2	2
	0.2	FRN0002E2■-2□	2	2	2	2	2	2
	0.4	FRN0004E2■-2□	2	2	2	2	2	2
	0.75	FRN0006E2■-2□	2	2	2	2	2	2
	1.5	FRN0010E2■-2□	2	2	2	2	2	2
	2.2	FRN0012E2■-2□	2	2	2	2	2	2
	3.7	FRN0020E2■-2□	2	2	2	2	2	2
	5.5	FRN0030E2■-2□	2	3.5	3.5	2	2	2
	7.5	FRN0040E2■-2□	2	5.5	5.5	3.5	3.5	2
	11	FRN0056E2■-2□	5.5	8	5.5	5.5	5.5	2
	15	FRN0069E2■-2□	8	14	5.5	8	14	2
	18.5	FRN0088E2■-2□	14	14	8	14	14	2
22	FRN0115E2■-2□	14	22	8	14	22	2	
Three-phase 400 V	0.4	FRN0002E2■-4□	2	2	2	2	2	2
	0.75	FRN0004E2■-4□	2	2	2	2	2	2
	1.5	FRN0006E2■-4□	2	2	2	2	2	2
	2.2	FRN0007E2■-4□	2	2	2	2	2	2
	3.7	FRN0012E2■-4□	2	2	2	2	2	2
	5.5	FRN0022E2■-4□	2	2	2	2	2	2
	7.5	FRN0029E2■-4□	2	2	2	2	2	2
	11	FRN0037E2■-4□	2	3.5	3.5	2	2	2
	15	FRN0044E2■-4□	2	5.5	5.5	2	3.5	2
	18.5	FRN0059E2■-4□	3.5 ^{*4}	5.5	5.5	3.5 ^{*4}	5.5	2
	22	FRN0072E2■-4□	5.5	8 ^{*1}	5.5	5.5	5.5	2
	30	FRN0085E2■-4□	8	14	8	8	8	-
	37	FRN0105E2■-4□	8	14	8	14	14	-
	45	FRN0139E2■-4□	14	22	8	14	22	-
	55	FRN0168E2■-4□	22	38	14	22	22	-
	75	FRN0203E2■-4□	38	-	14	38	38	-
	90	FRN0240E2■-4□	38	-	14	38	60	-
110	FRN0290E2■-4□	60	-	22	60	60	-	
132	FRN0361E2■-4□	60	-	22	100	100	-	
160	FRN0415E2■-4□	100	-	22	100	150	-	
200	FRN0520E2■-4□	150	-	38	150	150	-	
220	FRN0590E2■-4□	150	-	38	150	200	-	
Single-phase 200 V	0.1	FRN0001E2■-7□	2	2	2	2	2	2
	0.2	FRN0002E2■-7□	2	2	2	2	2	2
	0.4	FRN0003E2■-7□	2	2	2	2	2	2
	0.75	FRN0005E2■-7□	2	2	2	2	2	2
	1.5	FRN0008E2■-7□	2	2	2	2	2	2
	2.2	FRN0011E2■-7□	2	2	2	2	2	2

The recommended wire sizes for the main circuit terminals assume using 90°C 600 V FSLC wire.

*1 For compatible crimped terminals, please use model 8-L6 by JST Mfg. Co., Ltd. or equivalent.

*4 For compatible crimped terminals, please use model R5.5-6 by JST Mfg. Co., Ltd. or equivalent.

[4] Description of terminal functions (main circuit terminal)

Classification	Terminal symbol	Terminal name	Specification
Main circuit	L1/R, L2/S, L3/T	Main power input	Terminals to connect Three-phase power source.
	L1/L, L2/N	Main power input	Terminals to connect Single-phase power source.
	U, V, W	Inverter output	Terminals to connect Three-phase motors.
	P (+), P1	For direct current reactor connection	Terminals to connect DC reactor (DCR) for power factor enhancement. It must be connected in the following cases: ND mode: Types FRN0139E2■-4□ or above. HD/HND mode: Types FRN0168E2■-4□ or above. HHD mode: Types FRN0203E2■-4□ or above.
	P (+), N (-)	For direct current bus connection	Terminals to connect direct current intermediate circuit of other inverters and PWM converters.
	P (+), DB	For braking resistor connection	Terminals to connect a braking resistor (optional). Wiring length: Below 5 meters. (Types FRN0115E2■-2□/FRN0072E2■-4□/FRN0011E2■-7□ or below)
	 G	For inverter chassis (case) grounding	Grounding terminal for inverter chassis (case).
	R0, T0	Auxiliary power input for control circuit	When it is desired to retain the alarm signal for the activation of the protective function even inverter main power supply shut off or when continuous display of the keypad is desired, connect this terminal to the power supply. (Types FRN0088E2■-4□/FRN0059E2■-4□ or above)
	R1, T1	Auxiliary power input for fan	Ordinarily, these terminals do not need to be connected. Connect these terminals to AC power supply when operating with direct current power input (such as in combination with PWM converters). (Types FRN0203E2■-4□ or above)

Follow the sequence below when wiring.

- (1) Inverter ground terminal (zG)
- (2) Inverter output terminals (U, V, W), motor ground terminal (zG)
- (3) Direct current reactor connection terminals (P1, P(+))*
- (4) Braking resistor connection terminals (P(+), DB)*
- (5) Direct current bus connection terminals (P(+), N(-))*
- (6) Main power supply input terminals (L1/R, L2/S, L3/T) or (L1/L, L2/N)
- (7) Auxiliary power input for control circuit (R0, T0) *

*: Connect if necessary.

Connect in the order (1), (2), (6), (3), (4), (5), (7) for the following models.

FRN0010 to 0020E2S-2□, FRN0002 to 0012E2S-4□, FRN0008 to 0011E2S-7□

(1) Main power source input terminals L1/R, L2/S, L3/T (Three-phase input) or L1/L, L2/N (Single-phase input)

Connect the Three-phase power source for Three-phase input model. Connect the Single-phase power source for Single-phase input model.

- 1) For safety, confirm that the circuit breaker (MCCB) or the magnetic contactor (MC) is OFF prior to wiring the power lines.
- 2) Connect the power lines (L1/R, L2/S, L3/T) or (L1/L, L2/N) to MCCB or residual-current-operated protective device (RCD)/ the earth leakage breaker (ELCB)*, or connect via MC if necessary. The phase sequence of the power lines and the inverter do not need to be matched.

*: With overcurrent protection

Tip In emergencies such as when the inverter protective function is activated, disconnecting the inverter from the power source to prevent magnification of failure or accident may be desired. Installation of an MC which allows manual disconnection of the power source is recommended.

(2) Inverter output terminals U, V, W, motor ground terminal $\oplus G$

- 1) Connect the Three-phase motor terminals U, V, and W while matching the phase sequence.
- 2) Connect the ground line of the outputs (U, V, W) to the ground terminal ($\oplus G$).

Note When multiple combinations of inverters and motors exist, do not use multi-core cables for the purpose of bundling the various wires.

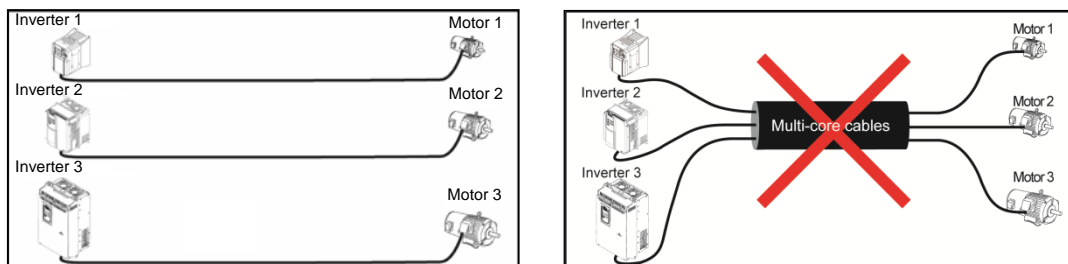

(3) Direct current reactor connection terminals P1, P(+)

Connect the direct current reactor (DCR) for power factor enhancement.

- 1) Remove the shorting bar from terminals P1-P(+).
(Types FRN0203E2-4 or above will not have the shorting bar connected.)
- 2) Connect the P1, P(+) terminals to the direct current reactor (option).

Note

- Keep the wiring length below 10 meters.
- Do not remove the shorting bar if the direct current reactor is not used.
- When the capacity of the motor to be used is above 75 kW, always connect the direct current reactor.
- Direct current reactors do not have to be connected when connecting PWM converters.

⚠ WARNING

Always connect the direct current reactor (option) when the power supply transformer capacity is above 500 kVA and is over 10 times the rated capacity of the inverter.

Risk of fire exists.

**(4) Braking resistor connection terminals P(+), DB
(Types FRN0115E2-2 / FRN0072E2-4 / FRN0011E2-7 or below)**

- 1) Connect terminals P(+), DB of the inverter to braking resistor terminals (option).
- 2) Mount the inverter main body and the braking resistor such that the wiring length will be less than 5m (16ft) and route the two wires twisted or in contact with each other (parallel).

⚠ WARNING

Do not connect to terminals other than P(+)-DB when connecting braking resistors.

Risk of fire exists.

(5) Direct current bus terminals P(+), N(-)

1) Connecting the braking unit/braking resistor (option)

Inverter type	Braking transistor	Additional instruments for connection (option)	Instruments connected/connection terminals
Types FRN0085E2■-4□ or below	Not equipped	Braking unit	Inverter (P(+), N(-)) - Braking unit (P(+), N(-))
		Braking resistor	Braking unit (P(+) R, DB) - Braking resistor (P, DB)

Braking units are necessary when using braking resistors for types FRN0085E2■-4□ or above.

Connect terminals P(+), N(-) of the braking unit to the inverter terminals P(+), N(-). Mount the equipment such that the wiring length is below 5m (16ft) and route the two wires twisted or in contact with each other (parallel).

Connect the terminals P(+) R, DB of the braking unit to terminals P(+), DB of the braking resistor. Mount the equipment such that the wiring length is below 10m (33ft) and route the two wires twisted or in contact with each other (parallel).

For details such as other wirings, refer to the user's manual for the braking unit.

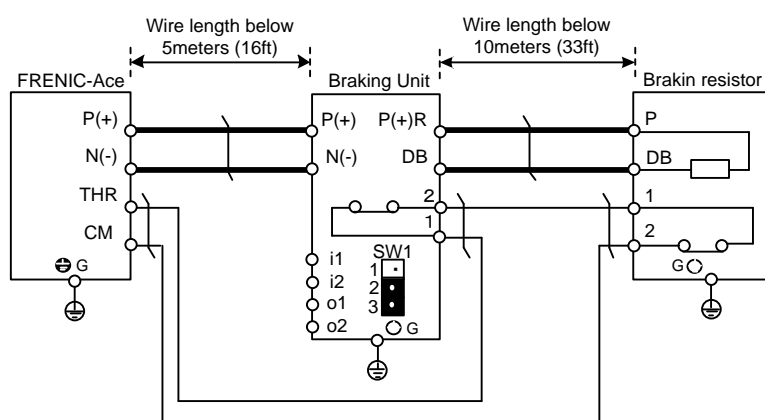

Figure 2.2-9

2) Connection of other instruments

The direct current intermediate circuit of other inverters and PWM converters can be connected.

(For connection with the PWM converter, refer to the FRENIC-Ace User's Manual, Chapter 11 "11.9 Power Regenerative PWM Converters, RHC Series").

(6) Inverter ground terminal ⚡G

This terminal is the ground terminal for the inverter chassis (case). Always connect to ground for safety and as a countermeasure for noise. To prevent accidents such as electric shock and fire, the electrical safety standards require grounding construction for metallic frames in electric instruments.

Follow the steps below in connecting the ground terminal on the power supply side.

- 1) Ground the inverter in compliance with the national or local electric code.
- 2) The grounding wire size should be as described before in this chapter, with large surface area, and as short as possible.

(7) Auxiliary power input terminals for control circuit R0, T0 (Types FRN0088E2-2□ / FRN0059E2-4□ or above)

The inverter can be operated without power input to the auxiliary power input terminals for control circuit. However, the inverter output signals and the keypad display will be shut off when the inverter main power is shut off and the control power source is lost.

When it is desired to retain the alarm signal for the activation of the protective function even inverter main power supply shut off, or when continuous display of the keypad is desired, connect these terminals to the power supply. When the inverter input side has a magnetic contactor (MC), wire from the input side (primary side) of the magnetic contactor (MC).

Terminal rating: AC 200 to 240 V, 50/60 Hz, maximum current 1.0 A (200 V series)
 AC 380 to 480 V, 50/60 Hz, maximum current 0.5 A (400 V series)

Note When using the earth leakage breaker, connect terminals R0, T0 to the output side of the earth leakage breaker.

When connections are made to the input side of the earth leakage breaker, the earth leakage breaker will malfunction because the inverter input is three-phase and the terminals R0, T0 are single phase. When connecting to terminals R0, T0 to the input side of the earth leakage breaker, make sure that the connection is done through an insulating transformer or, alternatively, through the auxiliary B contacts of the magnetic contactor as shown in the figure below.

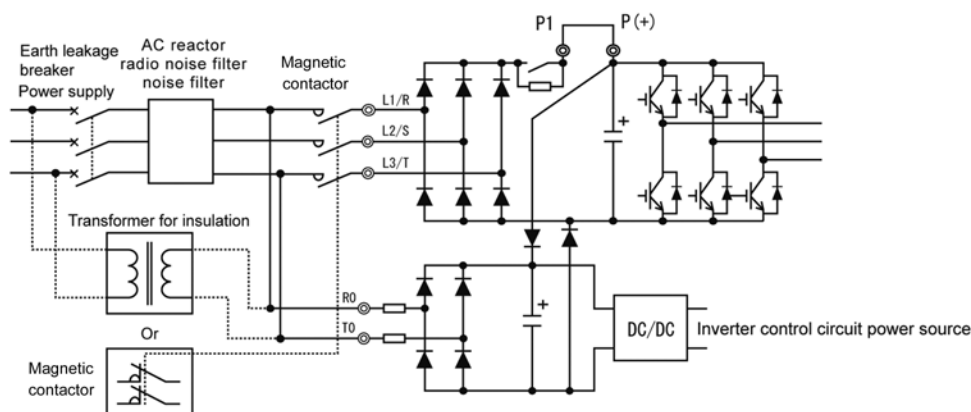

Figure 2.2-10 Connection of the Earth Leakage Breaker

Note When connecting with the PWM converter, do not connect power source directly to the inverter's auxiliary power input terminals (R0, T0) for control circuit. Insert an insulating transformer or the auxiliary B contacts of a magnetic contactor on the power supply side.

On connection examples for the PWM converter side, refer to the FRENIC-Ace User's Manual, Chapter 11 "11.9 Power Regenerative PWM Converters, RHC Series".

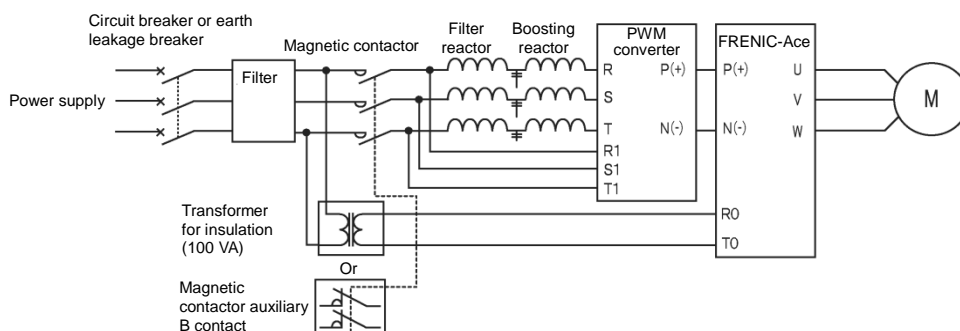

Figure 2.2-11 Example of connection of R0, T0 terminals in combination with PWM converter

(8) Auxiliary power input terminals for fan R1, T1 (Types FRN0203E2-4□ or above)

These terminals are equipped on types FRN0203E2-4□ or below, but are not used ordinarily.

Connect the AC power source when using direct current power supply input (such as in combination with PWM converters).

Also switch the fan power supply switching connectors "CN R", "CN W".

Terminal rating: AC 380 to 440 V/50 Hz, 380 to 480 V/60 Hz, maximum current 1.0 A (400 V series)

2.2.6 Control circuit terminals (common to all models)

[1] Screw specifications and recommended wire size (control circuit terminals)

The screw specifications and wire sizes to be used for control circuit wiring are shown below.
The control circuit terminal board differs depending on the destination.

Table 2.2-28 Screw Specifications and Recommended Wire Sizes

Terminal symbol	Screw specification		Allowable wire sizes	Driver (shape of tip)	Removal size of wire cover 	Gauge size to insert wire
	Size	Tightening torque				
30A, 30B, 30C EN1, EN2	M3	0.5 N·m (4.43 lb-in)	0.14 to 1.5 mm ² (AWG26 to 16)	Minus (0.6mm×3.5mm)	6 mm (0.24 in)	A1 ^{*1}
Others	M2	0.19 N·m (1.68 lb-in)	0.25 to 1 mm ² (AWG24 to 18)	Minus (0.4mm×2.5mm)	5 mm (0.20 in)	φ1.6

* Recommended rod terminal: Phoenix Contact Refer to Table 2.2-29 for details.

*1 Defined according to IEC/EN 60947-1.

Table 2.2-29 Recommended Rod Terminals

Screw size	Wire size	Type		
		With insulating collar	Without insulating collar	
M3	M2	0.25 mm ² (AWG24)	AI 0.25-6 BU	A 0.25-7
		0.34 mm ² (AWG22)	AI 0.34-6 TQ	A 0.34-7
		0.5 mm ² (AWG20)	AI 0.5-6 WH	A 0.5-6
	M3	0.75 mm ² (AWG18)	AI 0.75-6 GY	A 0.75-6
		1 mm ² (AWG18)	AI 1-6 RD	A 1-6
		1.5 mm ² (AWG16)	AI 1.5-6 BK	A 1.5-7

Note) When sizes exceeding the recommended wire sizes are used, the front cover may be pushed outward depending on the number of wires, causing erroneous operation of the keypad.

[2] Terminal layout diagram (control circuit terminal)

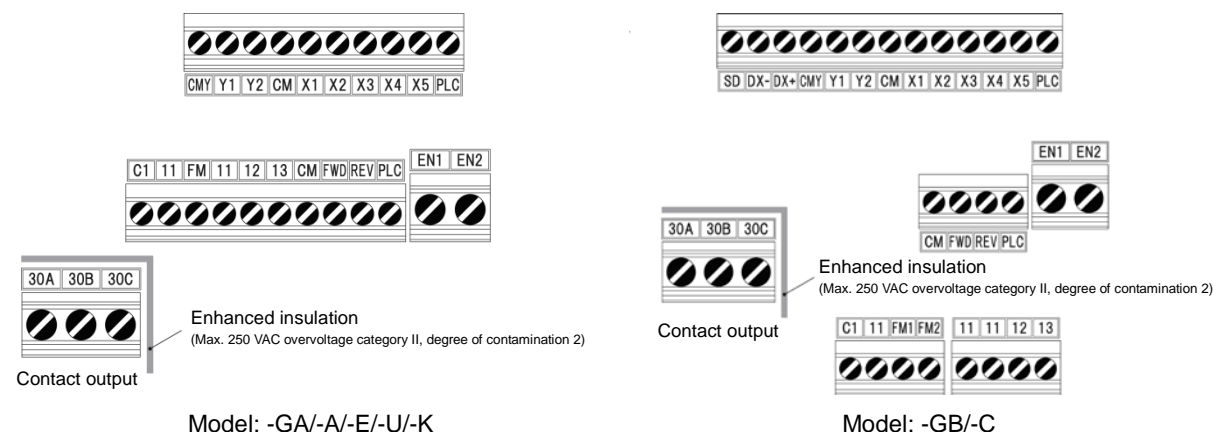

⚠ WARNING ⚠
<p>The following terminals may have high voltage when the power is ON. Control terminals: AUX-contact (30A, 30B, 30C) Insulation level Contact output – control circuit : Enhanced insulation (overvoltage category II, degree of contamination 2)</p> <p>Risk of electric shock exists</p>

[3] Description of terminal functions (control circuit terminal)

⚠ WARNING ⚠

Generally, the insulation for control signal lines is not enhanced. When the control signal lines come into direct contact with the main circuit live section, the insulation cover may be damaged. High voltage of the main circuit may be applied on the control signal lines, so exercise caution such that the main circuit live sections do not contact the control signal lines.

Risk of accidents and risk of electric shock exist.

⚠ CAUTION

Noise is generated by the inverter, motor, and wiring.

Exercise caution to prevent malfunction of peripheral sensors and instruments.

Risk of accidents exists.

Table 2.2-30 shows the functional explanations for the control circuit terminals. The connection method of the control circuit terminals differs depending on the functional code setting matching the purpose of inverter operation. Properly wire such that the impact of noise generated by the main circuit wiring is reduced.

Table 2.2-30 Functional Description of Control Circuit Terminals

Classification	Terminal symbol	Terminal name	Functional description
Analog input	[13]	Power supply for the potentiometer	The terminal is used for the power supply (DC+10 V 10 mA Max) for the external frequency command potentiometer (variable resistor: 1 to 5 kΩ). Connect variable resistors larger than 1/2 W.
	[12]	Analog setup voltage input	(1) Frequency is set up according to the external analog voltage input command value. Normal operation <ul style="list-style-type: none"> DC0 to +10 V/0 to 100(%) (DC0 to +5 V/0 to 100%) DC0 to ±10 V/0 to ±100(%) (DC0 to ±5 V/0 to ±100%) Reverse operation <ul style="list-style-type: none"> DC+10 to 0V/0 to 100(%) (DC+5 to 0 V/0 to 100%) DC±10 to 0V/0 to ±100(%) (DC±5 to 0V/0 to ±100%) (2) The terminal can be assigned to PID command, feedback signal of PID control, auxiliary frequency setup, ratio setup, torque limit setup, and analog input monitor aside from the frequency setup by analog input. (3) Hardware specification <ul style="list-style-type: none"> * Input impedance: 22 (kΩ) * Up to DC±15 V can be input. However, input exceeding DC±10 V will be recognized as DC±10 V.
	[C1]	Analog setup current input (C1 function)	(1) Frequency is set up according to the external analog current input command value. Normal operation <ul style="list-style-type: none"> DC4 to 20 mA/0 to 100(%)/-100% to 0 to 100% DC0 to 20 mA/0 to 100(%)/-100% to 0 to 100% Reverse operation <ul style="list-style-type: none"> DC20 to 4 mA/0 to 100(%)/-100% to 0 to 100% DC20 to 0 mA/0 to 100(%)/-100% to 0 to 100% (2) The terminal can be assigned to PID command, feedback signal of PID control, auxiliary frequency setup, ratio setup, torque limit setup, and analog input monitor aside from the frequency setup by analog input. (3) Hardware specification <ul style="list-style-type: none"> * Input impedance: 250 (Ω) * Up to DC 30 mA can be input. However, input exceeding DC 20 mA will be recognized as DC 20 mA.

Table 2.2-30 Functional Description of Control Circuit Terminals (continued)

Classification	Terminal symbol	Terminal name	Functional description
Analog input	[C1]	Analog setup voltage input (V2 function)	<p>(1) Frequency is set up according to the external analog voltage input command value. SW3 (refer to "2.2.8 Operating slide switches") must be switched on the printed circuit board.</p> <p>Normal operation</p> <ul style="list-style-type: none"> • DC0 to +10 V/0 to 100% (DC0 to +5 V/0 to 100%) • DC0 to +10 V/-100 to 0 to 100% (DC0 to +5 V/-100 to 0 to 100%) <p>Reverse operation</p> <ul style="list-style-type: none"> • DC+10 to 0 V/0 to 100% (DC+5 V to 0 V/0 to 100%) • DC+10 to 0 V/-100 to 0 to 100% (DC+5 to 0 V/-100 to 0 to 100%) <p>(2) The terminal can be assigned to PID command, feedback signal of PID control, auxiliary frequency setup, ratio setup, torque limit setup, and analog input monitor aside from the frequency setup by analog input.</p> <p>(3) Hardware specification</p> <ul style="list-style-type: none"> * Input impedance: 22(kΩ) * Up to DC+15 V can be input. However, input exceeding DC+10 V will be recognized as DC+10 V.
	PTC thermistor input (PTC function)		<p>(1) PTC (Positive Temperature Coefficient) thermistor for motor protection can be connected. SW3 (C1/V2 Switch) and SW4 (PTC /AI Switch) (refer to "2.2.8 Operating slide switches") must be switched on the printed circuit board.</p> <p>Figure 2.2-12 shows the internal circuit when SW3 and SW4 are set for PTC thermistor input. For details on SW3 and SW4, refer to "2.2.8 Operating slide switches". When SW3 and SW4 are switched to the PTC side, function codes H26 and H27 also needs to be changed.</p>  <p style="text-align: center;">Figure 2.2-12 Internal circuit when SW4 is switched to PTC side</p>
	Analog input monitor (AI function)		<p>(1) The analog input monitor can be used to monitor the status of peripheral instruments using communication by inputting the analog signals of various sensors such as temperature sensors. Data can be converted to physical property values such as temperature and pressure by using display factors and shown on the keypad display.</p>
[11]	Analog input common		<p>The terminal is the common terminal for analog input signals (terminals [12], [13], [C1]). The terminal is insulated from terminals [CM], [CMY].</p>
Note			<ul style="list-style-type: none"> • Use shielded lines and keep the wiring to the minimum as possible (below 20 meters) for control signals which are susceptible to external noise. Grounding the shielded lines is generally recommended, but if external induction noise is large, connecting to terminal 11 may reduce the noise. The shielded line increases the blocking effect. Always ground one end as shown in Figure 2.2-13. • When inserting a relay contact at analog input signal lines, use the twin contacts relay for small signals. Also, do not insert a relay to terminal 11. • When external analog signal generators are connected, the analog signal generator circuit may malfunction due to the noise created by the inverter. In these cases, connect ferrite core (toroidal shape or equivalent) to the output terminals of the analog signal generator or connect high frequency capacitors between the control signal lines, as shown in Figure 2.2-14.   <p style="text-align: center;">Figure 2.2-13 Connection Diagram for Shielded Lines Figure 2.2-14 Example of Noise Countermeasures</p>

Table 2.2-30 Functional Description of Control Circuit Terminals (continued)

Classification	Terminal symbol	Terminal name	Functional description																									
Digital input	[X1]	Digital input 1	(1) Various signals (coast to a stop command, external alarm, multi-speed selection, etc) set up by function codes E01 to E05, E98, E99 can be set up. For details, refer to Chapter 5 "FUNCTION CODES".																									
	[X2]	Digital input 2	(2) Input mode, sink/source can be switched using SW1. (Refer to "2.2.8 Operating slide switches")																									
	[X3]	Digital input 3	(3) The operating mode of the various digital input terminals when connected with terminal CM (sink mode) / PLC (source mode) can be switched to "ON when shorted with CM/PLC (active ON)" or "OFF when shorted with CM/PLC (active OFF)"																									
	[X4]	Digital input 4																										
	[X5]	Digital input 5/pulse train input	(4) Digital input terminal [X5] can be set up as a pulse train input terminal by changing the function code Maximum wiring length 20 meters Maximum input pulse																									
	[FWD]	Run forward command	30 kHz: When connected to open collector output pulse generator 100 kHz: When connected to complementary output pulse generator For function code settings, refer to Chapter 5 "FUNCTION CODES"																									
	[REV]	Run reverse command	<p><Digital input circuit specification></p>  <table border="1" data-bbox="901 853 1359 1176"> <thead> <tr> <th colspan="2">Item</th> <th>Minimum</th> <th>Maximum</th> </tr> </thead> <tbody> <tr> <td rowspan="2">Operating voltage (SINK)</td> <td>ON level</td> <td>0 V</td> <td>2 V</td> </tr> <tr> <td>OFF level</td> <td>22 V</td> <td>27 V</td> </tr> <tr> <td rowspan="2">Operating voltage (SOURCE)</td> <td>ON level</td> <td>22 V</td> <td>27 V</td> </tr> <tr> <td>OFF level</td> <td>0 V</td> <td>2 V</td> </tr> <tr> <td colspan="2">Operating current at ON (at input voltage 0 V) (for [X5] input terminal)</td> <td>2.5 mA (9.7 mA)</td> <td>5 mA (16 mA)</td> </tr> <tr> <td colspan="2">Allowable leak current at OFF</td> <td>-</td> <td>0.5 mA</td> </tr> </tbody> </table> <p style="text-align: center;">Figure 2.2-15 Digital Input Circuit</p>	Item		Minimum	Maximum	Operating voltage (SINK)	ON level	0 V	2 V	OFF level	22 V	27 V	Operating voltage (SOURCE)	ON level	22 V	27 V	OFF level	0 V	2 V	Operating current at ON (at input voltage 0 V) (for [X5] input terminal)		2.5 mA (9.7 mA)	5 mA (16 mA)	Allowable leak current at OFF		-
Item		Minimum	Maximum																									
Operating voltage (SINK)	ON level	0 V	2 V																									
	OFF level	22 V	27 V																									
Operating voltage (SOURCE)	ON level	22 V	27 V																									
	OFF level	0 V	2 V																									
Operating current at ON (at input voltage 0 V) (for [X5] input terminal)		2.5 mA (9.7 mA)	5 mA (16 mA)																									
Allowable leak current at OFF		-	0.5 mA																									
[EN1] [EN2]	Enable input	<p>(1) When terminals [EN1]-[PLC] or terminals [EN2]-[PLC] are OFF, the inverter output transistors stop switching (safe torque off: STO). Be sure to operate terminals [EN1] and [EN2] simultaneously; otherwise an $ECCF$ alarm is issued and the operation of the inverter will be disabled. To enable the Enable function, remove the short bar.</p> <p>(2) The input mode for terminals [EN1] and [EN2] is fixed to source. The mode cannot be switched to sink.</p> <p>(3) Short terminals [EN1]-[PLC] and [EN2] - [PLC] using shorting bars when the enable input function is not used (Keep the shorting bar connected).</p> <p><EN terminal circuit spec></p>  <table border="1" data-bbox="895 1608 1311 1814"> <thead> <tr> <th colspan="2">Item</th> <th>Min</th> <th>Max</th> </tr> </thead> <tbody> <tr> <td rowspan="2">Operating voltage (SOURCE)</td> <td>ON level</td> <td>22 V</td> <td>27 V</td> </tr> <tr> <td>OFF level</td> <td>0 V</td> <td>2 V</td> </tr> <tr> <td colspan="2">Operating current at ON (at input voltage 24 V)</td> <td>-</td> <td>4.5 mA</td> </tr> <tr> <td colspan="2">Allowable leak current at OFF</td> <td>-</td> <td>0.5 mA</td> </tr> </tbody> </table>	Item		Min	Max	Operating voltage (SOURCE)	ON level	22 V	27 V	OFF level	0 V	2 V	Operating current at ON (at input voltage 24 V)		-	4.5 mA	Allowable leak current at OFF		-	0.5 mA							
Item		Min	Max																									
Operating voltage (SOURCE)	ON level	22 V	27 V																									
	OFF level	0 V	2 V																									
Operating current at ON (at input voltage 24 V)		-	4.5 mA																									
Allowable leak current at OFF		-	0.5 mA																									
[PLC]	Programmable controller signal power source	<p>(1) The terminal is used for connecting the output signal power source of the programmable controller (rated voltage DC +24 V (power supply voltage fluctuation range: DC +22 to +27 V) maximum 100 mA).</p> <p>(2) The terminal can also be used for the power source for the load connected to the transistor outputs. For details, refer to the page on "Transistor outputs".</p>																										

Table 2.2-30 Functional Description of Control Circuit Terminals (continued)

Classification	Terminal symbol	Terminal name	Functional description
Digital Input	[CM]	Digital common	This terminal is the common terminal for digital input signals. This terminal is insulated from terminals [11] and [CMY].
	<p>Tip</p> <p>■ When turning terminals [FWD], [REV], [X1] to [X5] ON and OFF using relay contacts</p> <p>Figure 2.2-16 shows an example of the circuit configuration using relay contact. Circuit (a) in Figure 2.2-16 shows the circuit configuration when the switch (SW1) is on the sink side and circuit (b) shows the circuit configuration when the switch is on the source side.</p> <p>Caution: Use a relay which will not have contact failures (high contact reliability). (Recommended product: Fuji Electric's control relay type: HH54PW)</p>  <p>(a) Switch on sink side (b) Switch on source side</p> <p>Figure 2.2-16 Circuit Configuration Example Using Relay Contact</p>		
Digital Input	<p>Tip</p> <p>■ When turning terminals [FWD], [REV], [X1] to [X5] ON and OFF using the programmable controller</p> <p>Figure 2.2-17 shows an example of the circuit configuration using programmable controller. Circuit (a) in Figure 2.2-17 shows the circuit configuration when the switch (SW1) is on the sink side and circuit (b) shows the circuit configuration when the switch is on the source side.</p> <p>In circuit (a), terminals [FWD], [REV], [X1] to [X5] can be turned ON/OFF by shorting/opening the open collector transistor output of the programmable controller using the external power supply. Follow the instructions below when using this type of circuit.</p> <ul style="list-style-type: none"> • Connect the + side of the external power supply which is insulated from the programmable controller power supply to terminal [PLC]. • Do not connect the inverter's [CM] terminal and the common terminal of the programmable controller.  <p>(a) Switch on the sink side (b) Switch on the source side</p> <p>Figure 2.2-17 Circuit Configuration Example Using Programmable Controller</p> <p>Refer to "2.2.8 Operating slide switches" for more information on the switches.</p>		

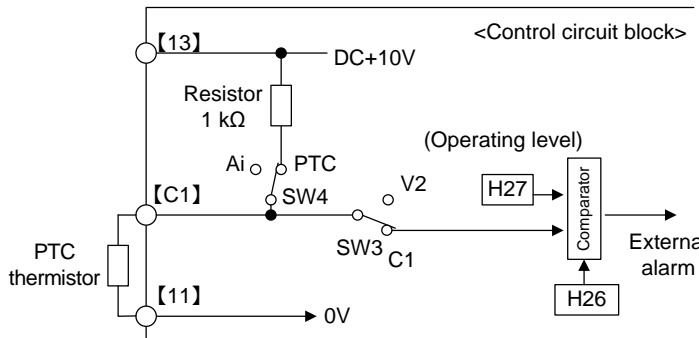
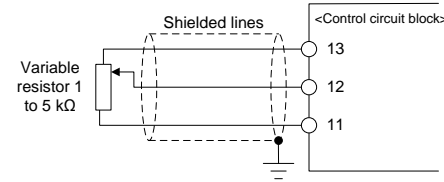
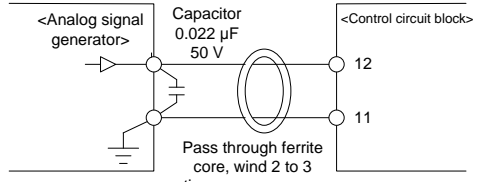
Table 2.2-30 Functional Description of Control Circuit Terminals (continued)

Classification	Terminal symbol	Terminal name	Functional description	
Analog output/pulse output	[FM]	Analog monitor FMV function FMI function	<p>This terminal outputs analog direct current voltage DC0 to 10 V or analog direct current DC4 to 20 mA / DC0 to 20mA monitor signal. The output form (FMV/FMI) can be switched using SW5 on the printed circuit board and function code F29. Refer to "Table 2.2-31 Functional Description of Slide switches".</p> <p>The signal content can be chosen in the function code F31 data setting among the following items.</p> <ul style="list-style-type: none"> • Output frequency 1 (before slip compensation) • Output frequency 2 (after slip compensation) • Output current • Output voltage • Output torque • Load factor • Input power • PID feedback value • Actual speed/estimated speed • DC link bus voltage • Universal AO • Motor output • Calibration (+) • PID command (SV) • PID output (MV) • Position error in master-follower operation • Inverter heat sink temperature • PG feedback value • Customizable logic output signal 1 to 10 <p>* Allowable impedance for connection: Min 5 kΩ (at DC to 10 V output) (up to 2 analog volt meters (DC0 to 10 V, input impedance 10 kΩ) can be connected.)</p> <p>* Allowable impedance for connection: Max 500 Ω (at DC4 to 20 mA/DC0 to 20 mA)</p> <p>* Gain adjustable range: 0 to 300%</p>	
		Pulse monitor FMP function	<p>The terminal outputs pulse signal. Signal content can be chosen same as for the FMV function by function code F31 setting. The output form (FMP) can be switched using SW5 on the printed circuit board and function code F29. Refer to "Table 2.2-31 Functional Description of Slide switches".</p> <p>* Allowable impedance for connection: Min. 5 kΩ (at DC to 10 V output) (up to 2 analog volt meters (DC0 to 10 V, input impedance 10 kΩ) can be connected.)</p> <p>* Pulse duty: Approximately 50%, pulse rate: 25 to 32000 p/s (at full scale)</p>	
			<table border="1" style="width: 100%; border-collapse: collapse;"> <tr> <td style="width: 50%; padding: 5px;"> <ul style="list-style-type: none"> • Pulse output waveform  </td> <td style="width: 50%; padding: 5px;"> <ul style="list-style-type: none"> • FMP output circuit  </td> </tr> </table>	<ul style="list-style-type: none"> • Pulse output waveform 
<ul style="list-style-type: none"> • Pulse output waveform 	<ul style="list-style-type: none"> • FMP output circuit 			
[FM2]	Analog monitor FMV2 function FMI2 function	<p>This terminal outputs analog direct current voltage DC0 to 10 V or analog direct current DC4 to 20 mA (DC0 to 20mA) monitor signal. The output form (FMV2/FMI2) can be switched using SW7 on the printed circuit board and function code F32. Refer to "Table 2.2-13 Functional Description of Slide switches".</p> <p>The signal content can be chosen in the function code F35 data setting among the same items with [FM] (F31).</p> <ul style="list-style-type: none"> * This terminal is used on the models with the destination codes -GB/-C. * Allowable impedance for connection: Min 5 kΩ (at DC to 10 V output) (up to 2 analog volt meters (DC0 to 10 V, input impedance 10 kΩ) can be connected.) * Allowable impedance for connection: Max 500 Ω (at DC4 to 20 mA/DC0 to 20 mA) * Gain adjustable range: 0 to 300% 		
[11]	Analog output common terminal	<p>This terminal is the common terminal for analog input and analog/pulse output signals. The terminal is insulated from terminals [CM] and [CMY]. Do not use [CM] and [CMY] as common terminals for [FM], [FM2].</p>		

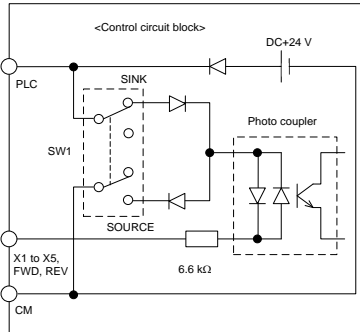
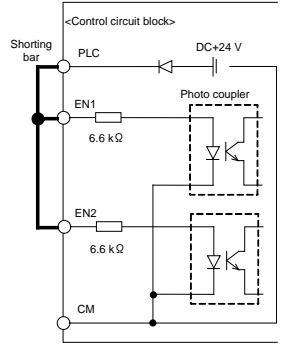
Table 2.2-30 Functional Description of Control Circuit Terminals (continued)

Classification	Terminal symbol	Terminal name	Functional description													
Transistor outputs	[Y1]	Transistor output 1	(1) Various signals (running signal, frequency reached signal, overload forecast signal, etc) set up by function code E20, E21 can be output. For details, refer to Chapter 5 "FUNCTION CODES".													
	[Y2]	Transistor output 2	<p>(2) The operating mode of the transistor output terminals [Y1], [Y2] can be switched to "ON (active ON) at signal output" or "OFF (active OFF) at signal output".</p> <p><Transistor output circuit specification></p> <div style="display: flex; align-items: center;">  <table border="1" style="margin-left: 20px;"> <thead> <tr> <th colspan="2">Item</th> <th>Maximum</th> </tr> </thead> <tbody> <tr> <td rowspan="2">Operating voltage</td> <td>ON level</td> <td>3 V</td> </tr> <tr> <td>OFF level</td> <td>27 V</td> </tr> <tr> <td colspan="2">Max load current at ON</td> <td>50 mA</td> </tr> <tr> <td colspan="2">Leak current at OFF</td> <td>0.1 mA</td> </tr> </tbody> </table> </div> <p style="text-align: center;">Figure 2.2-18 Transistor Output Circuit</p> <p>Note</p> <ul style="list-style-type: none"> Connect a surge absorbing diode between the terminals the excitation coil when connecting control relays. When a power source is needed for the circuit to be connected, terminal PLC can be used as a power source terminal. Rated voltage: DC+24 V (power supply voltage fluctuation range: DC+22 to +27 V), maximum 50 mA). In this case, terminal [CMY] must be shorted to terminal [CM]. 	Item		Maximum	Operating voltage	ON level	3 V	OFF level	27 V	Max load current at ON		50 mA	Leak current at OFF	
Item		Maximum														
Operating voltage	ON level	3 V														
	OFF level	27 V														
Max load current at ON		50 mA														
Leak current at OFF		0.1 mA														
[CMY]	Transistor output common	This terminal is the common terminal for transistor output signals.	This terminal is insulated from terminals [CM] and [11].													
Tip	<p>■ When connecting the programmable controller to terminals [Y1], [Y2].</p>															
	<p>The circuit configuration example for connecting the inverter transistor output to the programmable controller is shown in Figure 2.2-19. Circuit (a) in Figure 2.2-19 shows the programmable controller input circuit as sink input and circuit (b) shows as the source input case.</p> <div style="display: flex; justify-content: space-around;"> <div style="text-align: center;">  <p>(a) Connection diagram for sink input type programmable controller</p> </div> <div style="text-align: center;">  <p>(b) Connection diagram for source input type programmable controller</p> </div> </div> <p style="text-align: center;">Figure 2.2-19 Example of Connection Circuit Configuration with Programmable Controller</p>															
Contact output	[30A/B/C]	Integrated alarm output	<p>(1) When the inverter stops with an alarm, output is generated on the relay contact (1C). Contact rating: AC250 V 0.3 A $\cos\phi = 0.3$, DC48 V 0.5 A</p> <p>(2) Terminals can be switched to "Terminals [30A to 30C] shorted (excitation: active ON) at ON signal output" or "Terminals [30A to 30C] open (non-excitation: active OFF) at ON signal output"</p>													

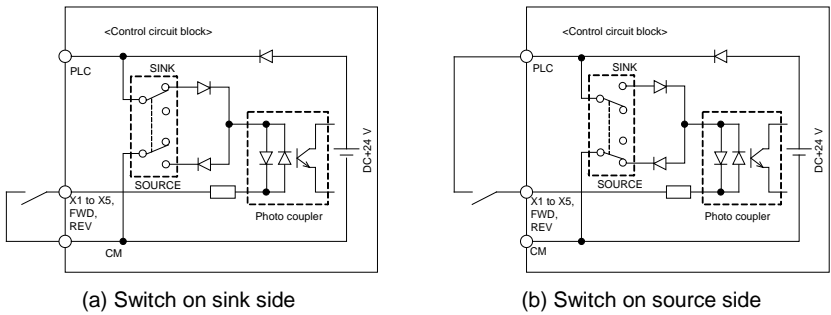
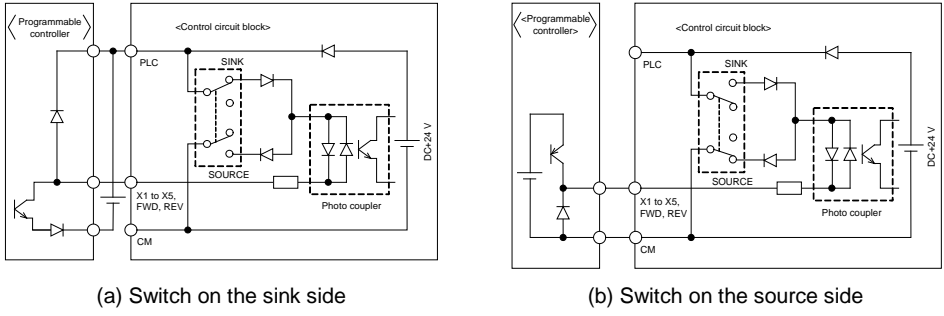
Table 2.2-30 Functional Description of Control Circuit Terminals (continued)

Classification	Terminal symbol	Terminal name	Functional description
Communication	RJ-45 connector for keypad connection	RJ-45 connector for keypad connection RS-485 communication port 1	(1) Used to connect the keypad. The power to the keypad will be supplied from the inverter through this connector. (2) Also can be used to connect a computer, programmable controller, etc by RS-485 communication, after removing the keypad. (On terminating resistor, refer to “2.2.8 Operating slide switches”).  <p style="text-align: center;">Figure 2.2-20 RJ-45 Connector Pin-layout</p> <ul style="list-style-type: none"> • Pins 1, 2, 7, and 8 are assigned as power supply source for the keypad. When connecting this RJ-45 connector to other devices, do not use these pins.
	RJ-45 connector for RS-485 /CANopen communication	RS-485 communication port 2 CANopen communication port	(1) Can be used to connect a computer, programmable controller, etc by RS-485 communication. (On terminating resistor, refer to “2.2.8 Operating slide switches”). (2) Also can be used to connect a computer, programmable controller, etc by CANopen communication. (On terminating resistor, refer to “2.2.8 Operating slide switches”).  <p style="text-align: center;">Figure 2.2-21 RJ-45 Connector Pin-layout</p> <ul style="list-style-type: none"> * This terminal is used on the models with the destination codes –GA/A/-E/-U/-K. * SW6 is shared between RS-485 communications and CAN bus communications. If both communications are used at the same time and the necessity of the terminating resistor for each communication network is different (for example in the CAN bus is located at either end of the network, but in the RS-485 network is located in the middle), turn SW6 “OFF” and use an external terminating resistor where needed.

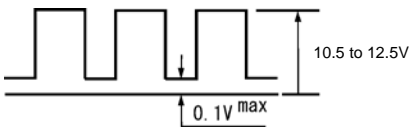
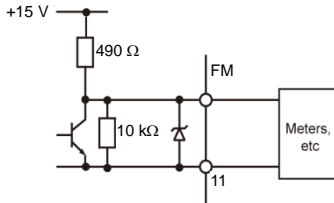
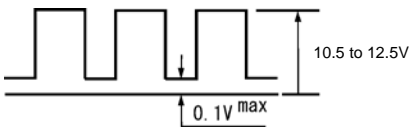
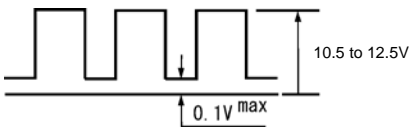
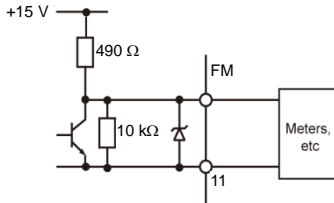
■ Wiring for control circuit terminals

For FRN0361E2■-4□ to FRN0590E2■-4□

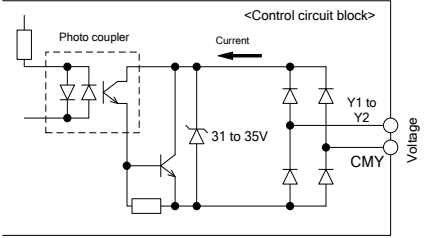
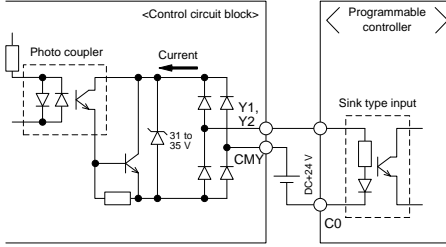
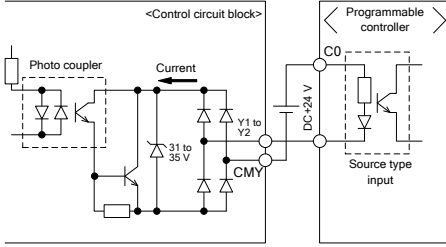
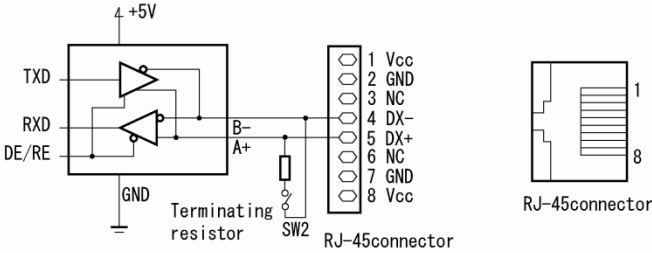
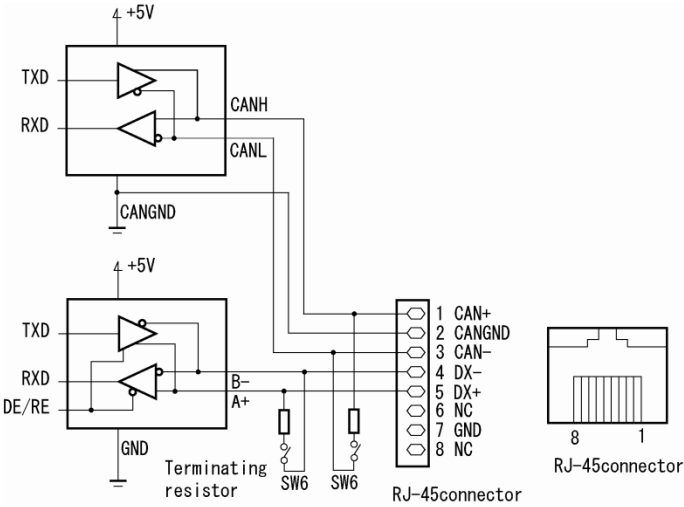
- (1) As shown in Figure 2.2-22, route the control circuit wires along the left side panel to the outside of the inverter.
- (2) Secure those wires to the wiring support, using a cable tie (e.g., Insulok) with 3.8 mm (0.15inch) or less in width and 1.5 mm (0.06inch) or less in thickness.

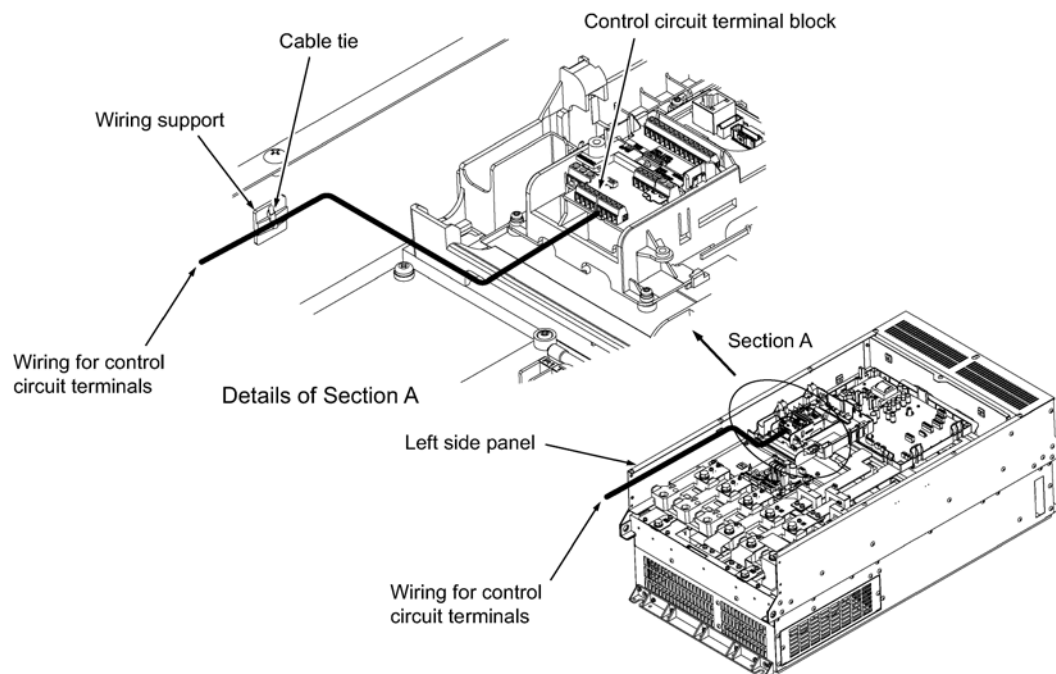

Figure 2.2-22 Wiring Route and Fixing Position for the Control Circuit Wires

- Note**
- Route the wiring of the control circuit terminals as far as possible from the wiring of the main circuit. Otherwise electric noise may cause malfunctions.
 - Fix the control circuit wires with a cable tie inside the inverter to keep them away from the live parts of the main circuit (such as the terminal block of the main circuit).

2.2.7 Switching connector (types FRN0203E2-4□ or above)

■ Position of each connector

The individual switching connectors are located on the power supply printed circuit board as shown in Figure 2.2-23.

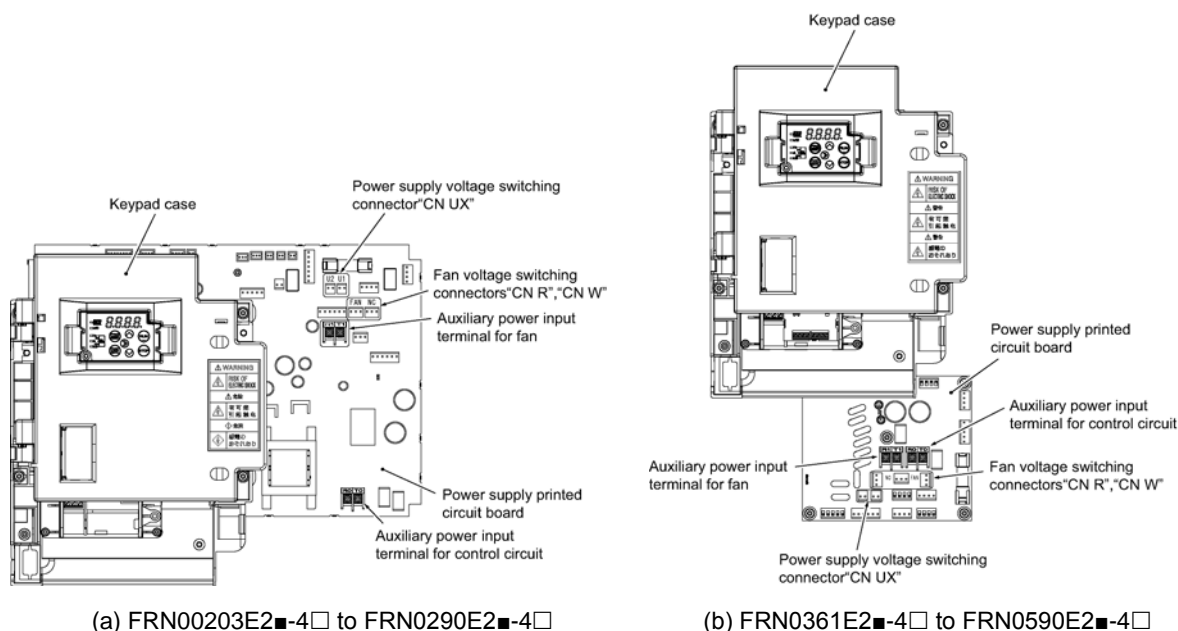
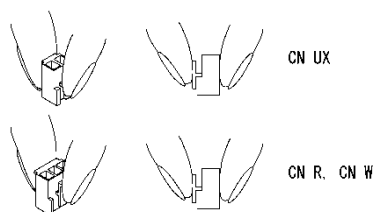

Figure 2.2-23 Switching Connector Positions



Note When removing the individual connectors, pinch the upper portion of the connector with the fingers, unlock the fastener, and pull. When inserting the connector, push in until the fastener lock engages with the receiving end with a click.

Figure 2.2-24 Attachment and Removal of the Switching Connector

■ Power supply switching connector “CN UX” (types FRN0203E2-4□ or above)

This power supply switching connector “CN UX” is equipped on FRN0203E2-4□ or above. Set the connector CN UX to U1 side (default) or U2 side depending on the power supply voltage specifications to be connected to the main power supply input terminals (L1/R, L2/S, L3/T) and/or the auxiliary power input terminals for the fan (R1, T1), according to the table below.

For details on the switching procedure, refer to “Figure 2.2-23 Switching Connector Positions” and “Figure 2.2-24 Attachment and Removal of the Switching Connector”.

(a) FRN0203E2-4□ to FRN0290E2-4□

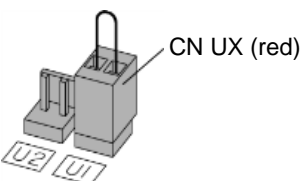
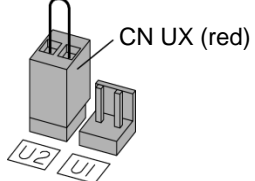
Setting		
Applicable voltage	398 to 440 V/ 50 Hz, 430 to 480 V/ 60 Hz (Factory default Model: -GA/-GB/-A/-E/-U/-K)	380 to 398V/ 50 Hz, 380 to 430 V/ 60 Hz (Factory default Model: -C)

(b) FRN0361E2■-4□ to FRN0590E2■-4□

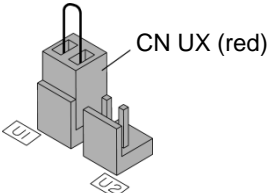
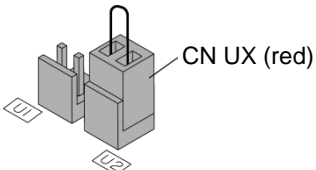
Setting		
Applicable voltage	398 to 440 V/ 50 Hz, 430 to 480 V/ 60 Hz (Factory default Model: -GA-/GB-/A-/E-/U-/K)	380 to 398V/ 50 Hz, 380 to 430 V/ 60 Hz (Factory default Model: -C)

■ Fan power source switching connector “CN R”, “CN W” (types FRN0203 E2■-4□ or above)

FRENIC-Ace supports direct current power supply input with PWM converters in the standard specification. However, FRN0203 E2■-4□ or above contains parts which are driven by AC power supply such as the AC fan, so AC power must also be supplied. When using DC power for the inverter, move connector “CN R” to **[NC]** side, move connector “CN W” to **[FAN]** side, and connect an AC power source to the auxiliary power input terminals for the fan (R1, T1).

For details on the switching procedure, refer to “Figure 2.2-23 Switching Connector Positions” and “Figure 2.2-24 Attachment and Removal of the Switching Connector”.

(a) FRN0203E2■-4□ to FRN0290E2■-4□

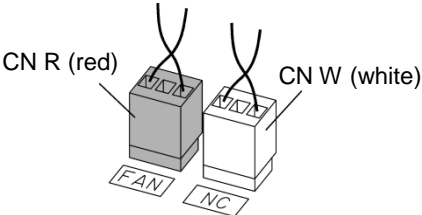
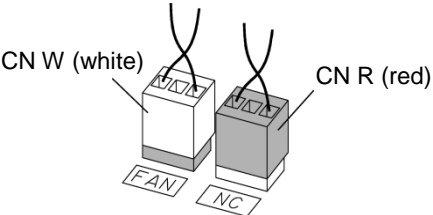
Setting		
Purpose	In the case terminals R1 and T1 are NOT used (Factory default)	In the case terminals R1 and T1 are used <ul style="list-style-type: none"> • DC bus input type • Combination with PWM converter

(b) FRN0361E2■-4□ to FRN0590E2■-4□

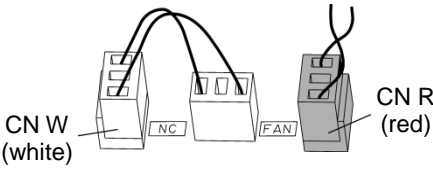
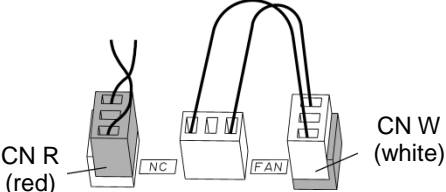
Setting		
Purpose	In the case terminals R1 and T1 are NOT used (Factory default)	In the case terminals R1 and T1 are used <ul style="list-style-type: none"> • DC bus input type • Combination with PWM converter

Note The fan power source switching connector “CN R” is on **[FAN]** and “CN W” is on **[NC]** when shipped from the factory. When direct current power supply input is not used, do not modify this setting. Mistakes in the fan power source switching connector setting may prevent the cooling fan from operating, and alarms such as cooling fin overheat **[OH]** and charging circuit error **[PLF]** may be generated.

2.2.8 Operating slide switches

⚠ WARNING ⚠

Operation of the slide switches should be conducted **after more than 5 minutes has elapsed** since power is shut off for types FRN0115E2-2□ / FRN0072E2-4□ or below and **after more than 10 minutes has elapsed for types FRN0085E2-4□ or above**. Confirm that the LED monitor and the charge lamp are turned off, and that the direct current intermediate circuit voltage between the main circuit terminals P(+)-N(-) is below the safe voltage (below DC+25 V) with a tester before operating the switches.

Risk of electric shock exists.

The I/O terminal specification can be changed, such as switching the analog output form, by operating the slide switches on the printed circuit board (Figure 2.2-25 The Slide Switch Locations on the Control Printed Circuit Board).

To operate the slide switches, remove the front cover and make the control printed circuit board visible. (For types FRN0085E2-4□ or above, also open the keypad case).

Refer to “2.2.2 Removal and attachment of the front cover/ terminal cover and wiring guide” to remove the front cover and to open/close the keypad case.

The switch locations on the control printed circuit board are shown in Figure 2.2-25 below.

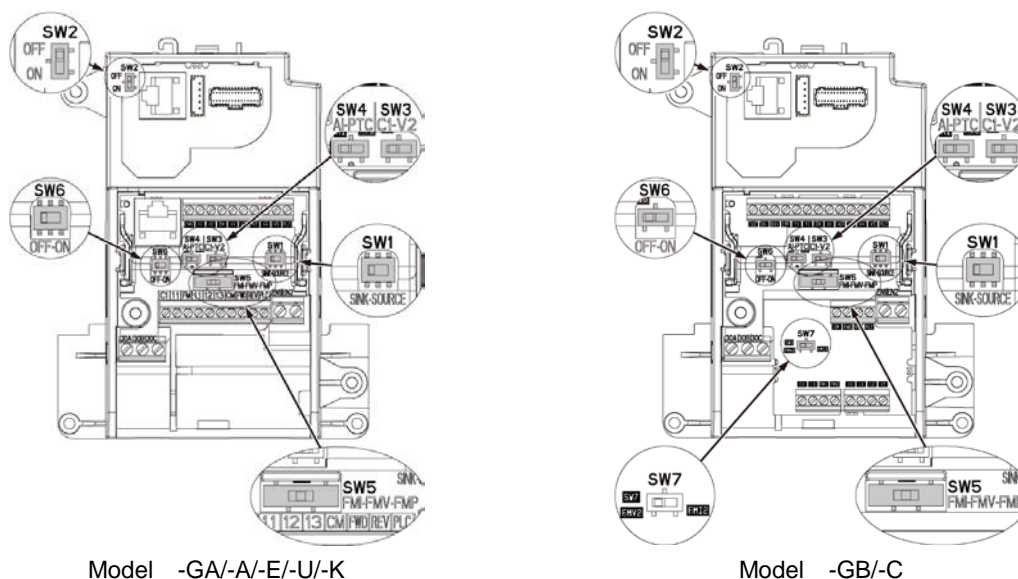

Model -GA/-A/-E/-U/-K

Model -GB/-C

Figure 2.2-25 The Slide Switch Locations on the Control Printed Circuit Board

	SW1	SW2	SW3	SW4	SW5	SW6	SW7
Various	SINK SOURCE	OFF ON	C1 V2	AI PTC	FMV FMP	OFF ON	FMV2 FM12
Factory default -GA/-GB -A/-E/-U/-K	SOURCE	OFF ON	C1	AI	FMV	OFF	FMV2
Factory default -C	SINK	OFF ON	C1	AI	FMV	OFF	FMV2

Note Use pointed devices (such as tweezers) to operate the switches. Avoid touching other electronic parts when moving the switches. The switch will be at open state when the slider is in the middle, so make sure to push the slider to the ends.

Functional description of the slide switches is explained in Table 2.2-31 Functional Description of Slide switches.

Table 2.2-31 Functional Description of Slide switches

Switch symbol	Functional description																								
SW1	<Switch to change sink/source setting of digital input terminals> <ul style="list-style-type: none"> This switch determines the type of input (sink or source) to use for digital input terminals [X1] to [X5], FWD, and REV. 																								
SW2	<Switch to change the RS-485 communication port 1 terminating resistor (RS-485 communication port (on the control PCB))> <ul style="list-style-type: none"> Move the switch to the ON side when RS-485 communication is used and the inverter is located at either end of the communication network. 																								
SW3 SW4	<Switch to change terminal [C1] input setting to current/voltage/PTC thermistor> This switch changes the input type for terminal [C1]. <table border="1" data-bbox="375 600 1385 761"> <thead> <tr> <th>Input type</th> <th>SW3</th> <th>SW4</th> <th>E59</th> <th>H26</th> </tr> </thead> <tbody> <tr> <td>Current input (factory default)</td> <td>C1 side</td> <td>AI side</td> <td>0</td> <td>0</td> </tr> <tr> <td>Voltage input</td> <td>V2 side</td> <td>AI side</td> <td>1</td> <td>0</td> </tr> <tr> <td>PTC thermistor input</td> <td>C1 side</td> <td>PTC side</td> <td>0</td> <td>1</td> </tr> </tbody> </table>					Input type	SW3	SW4	E59	H26	Current input (factory default)	C1 side	AI side	0	0	Voltage input	V2 side	AI side	1	0	PTC thermistor input	C1 side	PTC side	0	1
Input type	SW3	SW4	E59	H26																					
Current input (factory default)	C1 side	AI side	0	0																					
Voltage input	V2 side	AI side	1	0																					
PTC thermistor input	C1 side	PTC side	0	1																					
SW5	<Switch to change terminal [FM] output setting to current/voltage/pulse> This switch changes the output type for terminal [FM]. When operating this switch, also change function code F29. <table border="1" data-bbox="375 873 1385 1034"> <thead> <tr> <th>Output type</th> <th>SW5</th> <th>F29</th> </tr> </thead> <tbody> <tr> <td>Current output</td> <td>FMI side</td> <td>1 or 2</td> </tr> <tr> <td>Voltage output (factory default)</td> <td>FMV side</td> <td>0</td> </tr> <tr> <td>Pulse output</td> <td>FMP side</td> <td>3</td> </tr> </tbody> </table>					Output type	SW5	F29	Current output	FMI side	1 or 2	Voltage output (factory default)	FMV side	0	Pulse output	FMP side	3								
Output type	SW5	F29																							
Current output	FMI side	1 or 2																							
Voltage output (factory default)	FMV side	0																							
Pulse output	FMP side	3																							
SW6	<Switch to change the RS-485 communication port 2 terminating resistor (RS-485 communication port (on the terminal board))> <ul style="list-style-type: none"> Used for the RS-485/CANopen communication. Move the switch to the ON position when the inverter is located at either end of the communication network. 																								
SW7	<Switch to change terminal [FM2] output setting to voltage/current> The terminal is used only on the model with the destination code -C. This switch changes the output type for terminal [FM2]. When operating this switch, also change function code F32. <table border="1" data-bbox="375 1294 1385 1415"> <thead> <tr> <th>Output type</th> <th>SW7</th> <th>F32</th> </tr> </thead> <tbody> <tr> <td>Voltage output</td> <td>FMV2 side</td> <td>0</td> </tr> <tr> <td>Current output</td> <td>FMI2 side</td> <td>1 or 2</td> </tr> </tbody> </table>					Output type	SW7	F32	Voltage output	FMV2 side	0	Current output	FMI2 side	1 or 2											
Output type	SW7	F32																							
Voltage output	FMV2 side	0																							
Current output	FMI2 side	1 or 2																							

 Exercise caution as expected operation may not result if the setting above is not conducted accurately.

2.3 Attachment and Connection of Keypad

2.3.1 Parts required for connection

The following parts are necessary when attaching the keypad to locations other than the inverter main body.

Part name	Type	Remarks
Keypad extension cable (note 1)	CB-5S, CB-3S, CB-1S	Three lengths available (5 m, 3 m, 1 m) (3.3ft, 9.8ft, 16.4ft)
Keypad fixing screws	M3×□ (note 2)	2 screws required (prepared by user)

(Note 1) When using commercially available LAN cable, use 10BASE-T/100BASE-TX straight cables (below 20 meters) which meet the ANSI/TIA/EIA-568A category 5 standards of U.S.A.

Recommended LAN cable

Manufacturer: Sanwa Supply, Inc.

Type: KB-10T5-01K (for 1 meter)

KB-STP-01K (for 1 meter) (shielded cable when conforming to EMC directive)

(Note 2) When attaching to the cabinet, use a fixing screw of appropriate length to the cabinet thickness.

2.3.2 Attachment procedure

The keypad can be attached in the following forms.

- Attach to the inverter main body (refer to Figure 2.3-1 (a), (b), (c))
- Attach to the cabinet (refer to Figure 2.3-2)
- Operate the panel remotely, on the hand (refer to Figure 2.3-3)

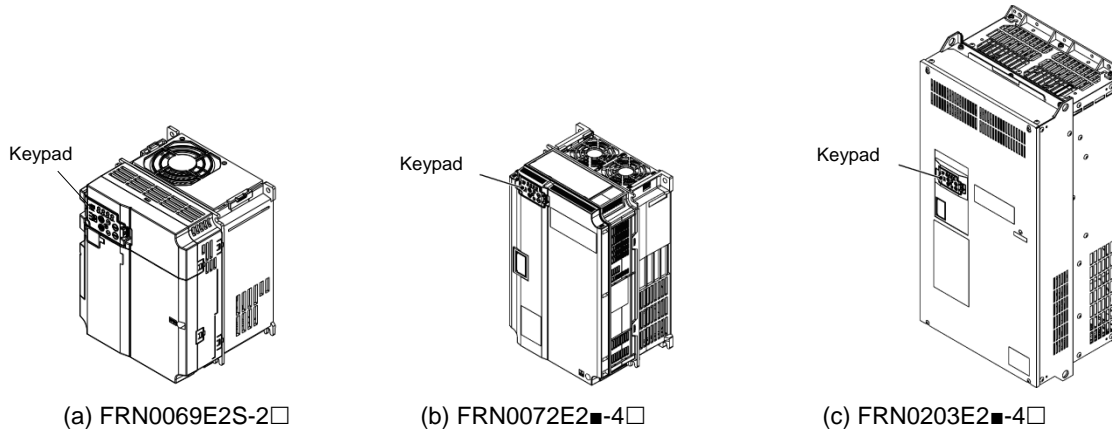

Figure 2.3-1 Attaching the Keypad to the Inverter Main Body

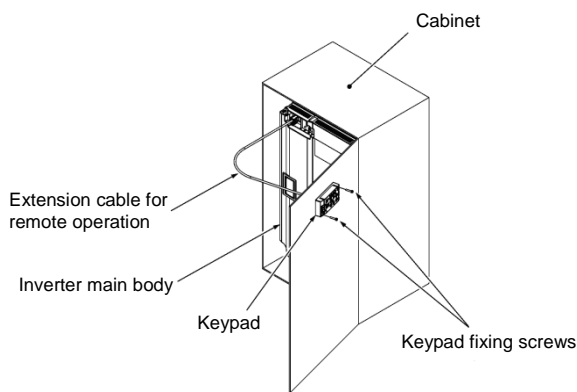

Figure 2.3-2 Attaching the Keypad on the Cabinet

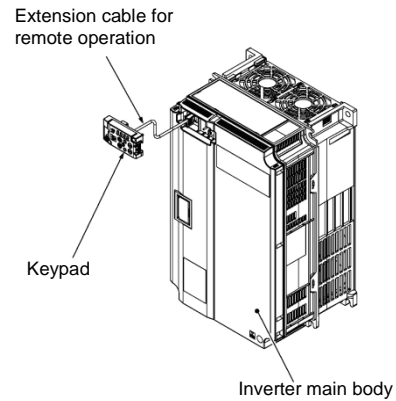

Figure 2.3-3 Operating the Keypad Remotely, on the Hand

■ Attachment to the cabinet

- (1) Squeeze the hooks at the arrows and pull as shown in Figure 2.3-4.

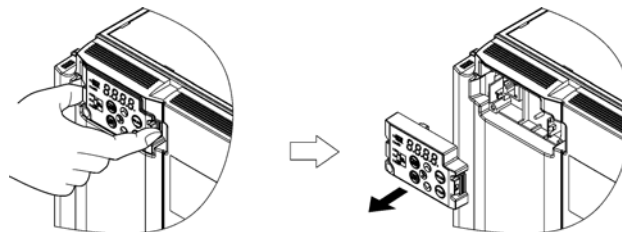

Figure 2.3-4 Removal of the Keypad

- (2) Attach the keypad rear cover to the keypad using the included keypad rear cover fixing screw.

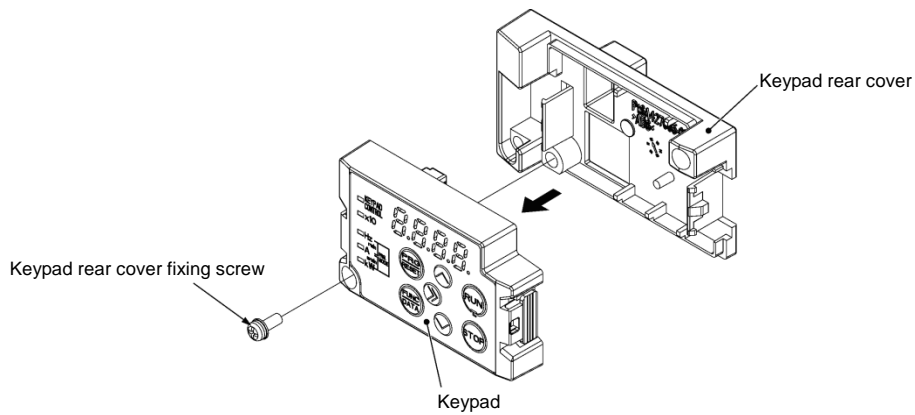

Figure 2.3-5 Attachment of the Keypad

- (3) Cut the cabinet to attach the keypad, as shown in Figure 2.3-6.

(Units: mm [inch])

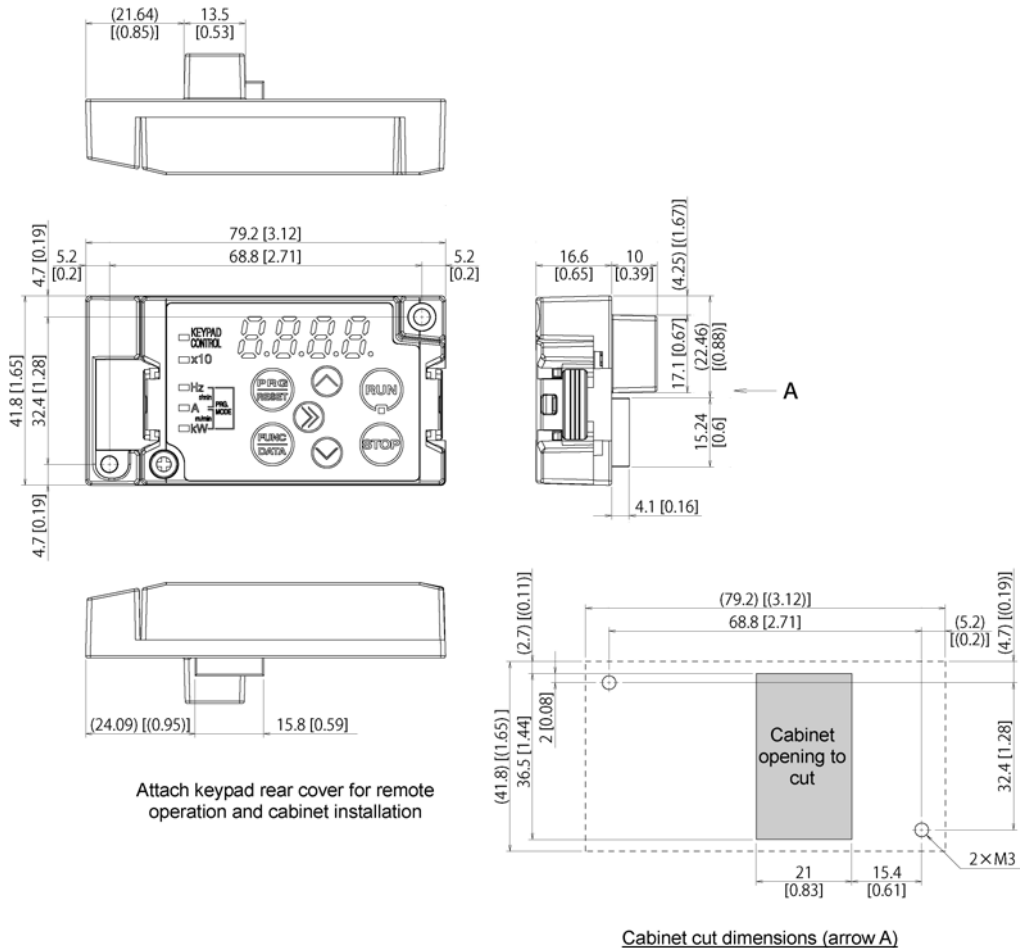

Figure 2.3-6 Fixing Screw Positions and the Dimensions of the Cabinet to Cut

- (4) Fix the keypad to the cabinet using 2 keypad rear cover fixing screws. (Refer to Figure 2.3-7) (tightening torque: 0.7 N•m(6.2lb-in))

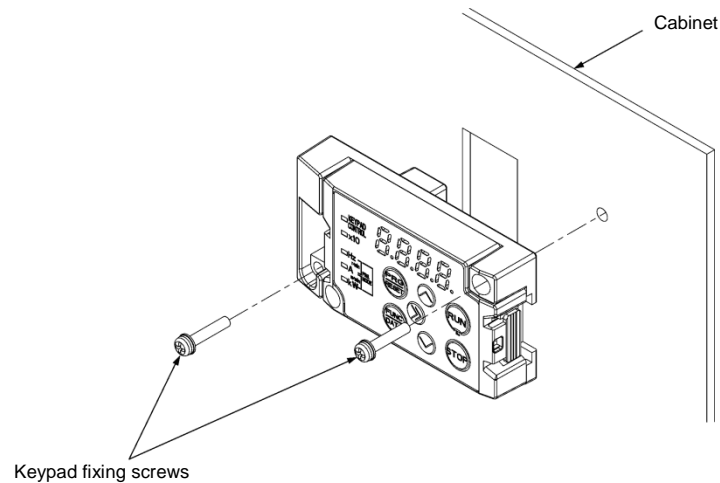

Figure 2.3-7 Attachment of the Keypad

- (5) Connect the extended cable for remote operation (CB-5S, CB-3S, CB-1S) or the commercially available LAN cable (straight) to the keypad RJ-45 connector and the inverter main body RJ-45 connector (modular jack). (Refer to Figure 2.3-8.)

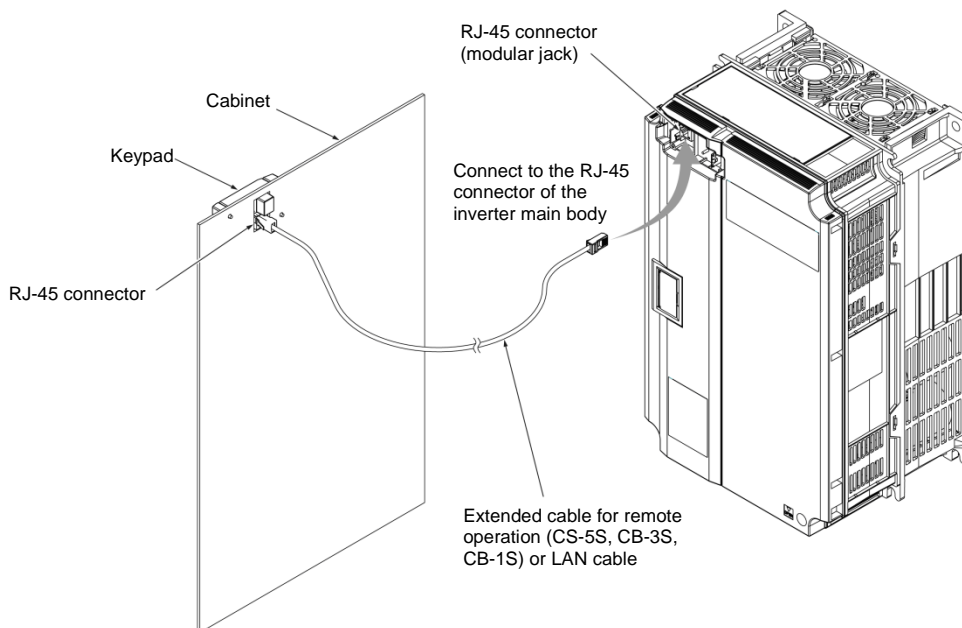

Figure 2.3-8 Connection of the Extension Cable or the Commercially Available LAN Cable between the Keypad and the Inverter Main Body

⚠ CAUTION

- Do not connect the inverter to PC LAN ports, Ethernet hubs, or telephone lines. The inverter and the connected instrument may be damaged.

Risk of fire and risk of accidents exist.

■ Operating remotely, on the hand

Connect following the procedure (5) in “■ Attachment to the cabinetAttachment to the cabinetAttachment to the cabinet”.

2.4 RJ-45 Cover

The opening for the RS-485 communication cable connection (RJ-45 connector) is located below the keypad, as shown in Figure 2.4-1 and Figure 2.4-2. There is not the RJ-45 connector in model GB and C.

■ Types FRN0069E2-2GA/AI-E/U-K / FRN0044E2-4GA/AI-E/U-K

FRN0011E2-7GA/AI-E/U-K or below

To connect the RS-485 communication cable, open the RJ-45 cover as shown in Figure 2.4-1.

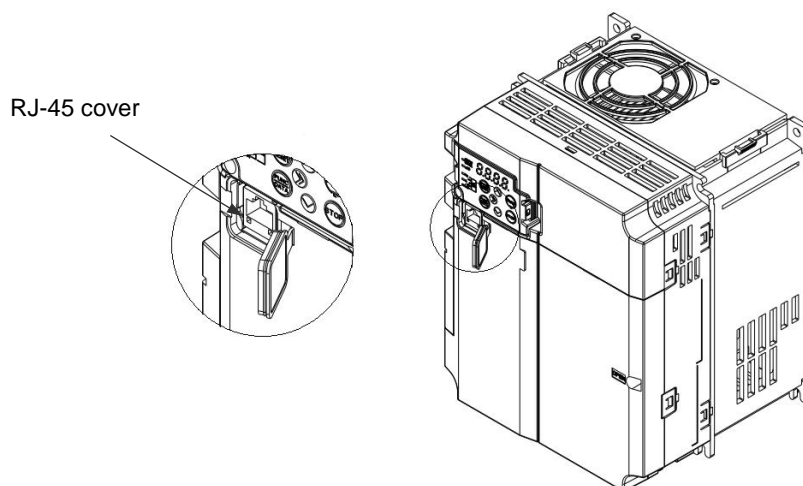

Figure 2.4-1 Connection of the RS-485 Communication Cable

■ Types FRN0088E2-2GA/AI-E/U-K / FRN0059E2-4GA/AI-E/U-K or above

To connect the RS-485 communication cable, open the RJ-45 cover until the “click” can be heard and connect the cable, as shown in Figure 2.4-2.

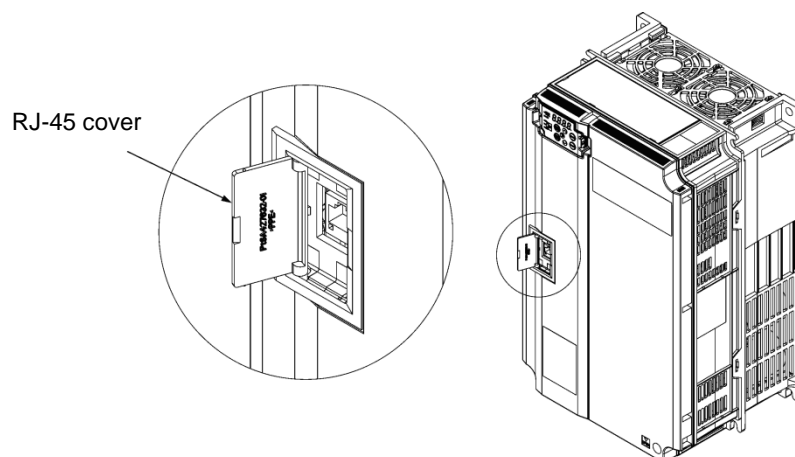

Figure 2.4-2 Connection of the RS-485 Communication Cable

Connect with the PC via the RS-485 converter using the RS-485 communication cable. The PC loader allows editing, confirmation, and management of the inverter function codes, and monitoring of operation data remotely. The operating status and alarms can also be monitored.

Chapter 3 OPERATION USING THE KEYPAD

Refer to the FRENIC-Ace User's Manual, Chapter 3 for details of the keypad.

3.1 Names and Functions of Keypad Components

The keypad allows you to run and stop the motor, display various data, configure function code data, and monitor I/O signal states, maintenance information and alarm information.

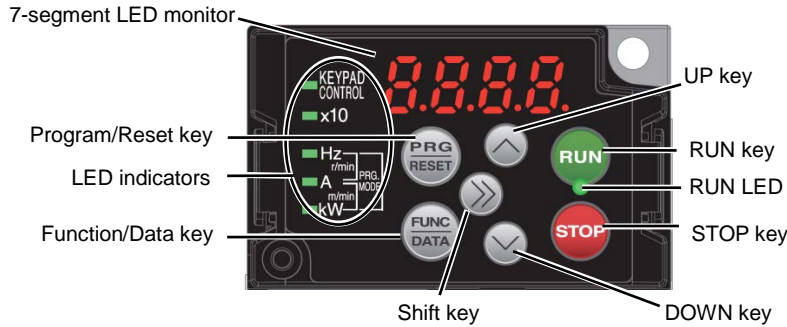





Table 3.1-1 Overview of Keypad Functions

Item	LED Monitor, Keys, and LED Indicators	Functions
LED Monitor		<p>Four-digit, 7-segment LED monitor which displays the followings according to the operation modes.</p> <ul style="list-style-type: none"> ■ In Running mode: Running status information (e.g., output frequency, current, and voltage) When a light alarm occurs, $L - FL$ is displayed. ■ In Programming mode: Menus, function codes and their data ■ In Alarm mode: Alarm code, which identifies the alarm factor that has activated the protective function.
Operation Keys		<p>Program/Reset key which switches the operation modes of the inverter.</p> <ul style="list-style-type: none"> ■ In Running mode: Pressing this key switches the inverter to Programming mode. ■ In Programming mode: Pressing this key switches the inverter to Running mode. ■ In Alarm mode: Pressing this key after removing the alarm factor resets the alarm and switches back to Running mode.
		<p>Function/Data key which switches the operations you want to do in each mode as follows:</p> <ul style="list-style-type: none"> ■ In Running mode: Pressing this key switches the information to be displayed concerning the status of the inverter (output frequency (Hz), output current (A), output voltage (V), etc.). When a light alarm is displayed, holding down this key resets the light alarm and switches back to Running mode. ■ In Programming mode: Pressing this key displays the function code or establishes the data entered with and keys. ■ In Alarm mode: Pressing this key displays the details of the problem indicated by the alarm code that has come up on the LED monitor.
		RUN key. Press this key to run the motor.
		STOP key. Press this key to stop the motor.
		UP and DOWN keys. Press these keys to select the setting items and change the function code data displayed on the LED monitor.
		Shift key. Press this key to shift the cursor to the right for entry of a numerical value.

3.1 Names and Functions of Keypad Components

Table 3.1-1 Overview of Keypad Functions (continued)

Item	LED Monitor, Keys, and LED Indicators	Functions
LED Indicators	RUN LED	Lights when running with a run command entered by the  key, by terminal command FWD or REV , or through the communications link.
	KEYPAD CONTROL LED	Lights when the inverter is ready to run with a run command entered by the  key (F02 = 0, 2, or 3). In Programming and Alarm modes, however, pressing the  key cannot run the inverter even if this indicator lights.
	Unit LEDs (3 LEDs)	These three LED indicators identify the unit of numeral displayed on the LED monitor in Running mode by combination of lit and unlit states of them. Unit: Hz, A, kW, r/min and m/min Refer to the FRENIC-Ace User's Manual, "3.3.1 Monitoring the running status" for details. While the inverter is in Programming mode, <input checked="" type="checkbox"/> Hz the LEDs of Hz and kW light. <input type="checkbox"/> A <input checked="" type="checkbox"/> kW
	x10 LED	Lights when the data to display exceeds 9999. When this LED lights, the "displayed value x 10" is the actual value. Example: If data is "12,345," the LED monitor displays  and the x10 LED lights, meaning that "1,234 × 10 = 12,340."

■ LED monitor

In Running mode, the LED monitor displays running status information (output frequency, current or voltage); in Programming mode, it displays menus, function codes and their data; and in Alarm mode, it displays an alarm code which identifies the alarm factor that has activated the protective function.

If one of LED4 through LED1 is blinking, it means that the cursor is at this digit, allowing you to change it.

If the decimal point of LED1 is blinking, it means that the currently displayed data is a value of the PID command, not the frequency data usually displayed.

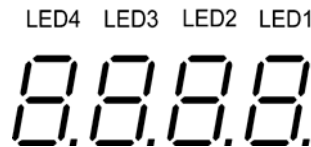









































Figure 3.1-1 7-Segment LED Monitor

Table 3.1-2 Alphanumeric Characters on the LED Monitor

Character	7-segment	Character	7-segment	Character	7-segment	Character	7-segment
0		9		i		r	
1		A		J		S	
2		b		K		T	
3		C		L		u	
4		d		M		v	
5		E		n		W	
6		F		o		X	
7		G		P		y	
8		H		q		Z	
Special characters and symbols (numbers with decimal point, minus and underscore)							
0. - 9.		-		_			

3.2 Overview of Operation Modes

The FRENIC-Ace features the following three operation modes.

Table 3.2-1 Operation Modes

Operation mode	Description
Running mode	When powered ON, the inverter automatically enters this mode. This mode allows you to specify the reference frequency, PID command value and etc., and run/stop the motor with the / keys. It is also possible to monitor the running status in real time. If a light alarm occurs, the $L-AL$ appears on the LED monitor.
Programming mode	This mode allows you to configure function code data and check a variety of information relating to the inverter status and maintenance.
Alarm mode	If an alarm condition arises, the inverter automatically enters Alarm mode in which you can view the corresponding alarm code* and its related information on the LED monitor. * Alarm code: Indicates the cause of the alarm condition. For details, first see “Table 6.1-1 Abnormal States Detectable (“Heavy Alarm” and “Light Alarm” Objects)” in Chapter 6 “6.1 Protective Function”, and then read the troubleshooting of each alarm.

Figure 3.2-1 shows the status transition of the inverter between these three operation modes.

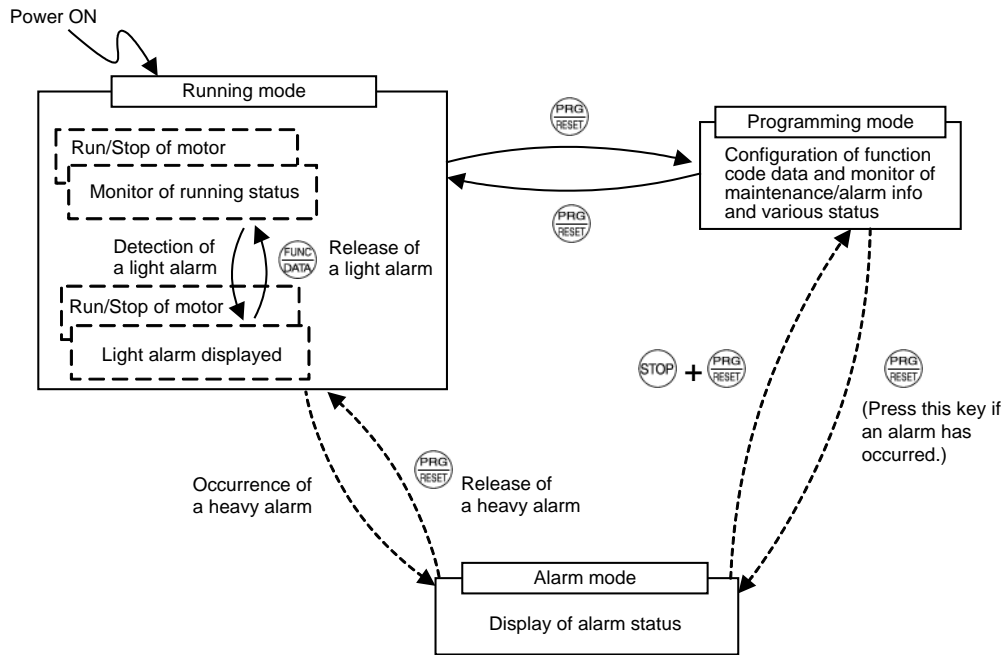

Figure 3.2-1 Status Transition between Operation Modes



Simultaneous keying

Simultaneous keying means pressing two keys at the same time. The simultaneous keying operation is expressed by a “+” letter between the keys throughout this manual.

For example, the expression “ + keys” stands for pressing the key with the key held down.

Figure 3.2-2 illustrates the transition of the LED monitor screen during Running mode, the transition between menu items in Programming mode, and the transition between alarm codes at different occurrences in Alarm mode.

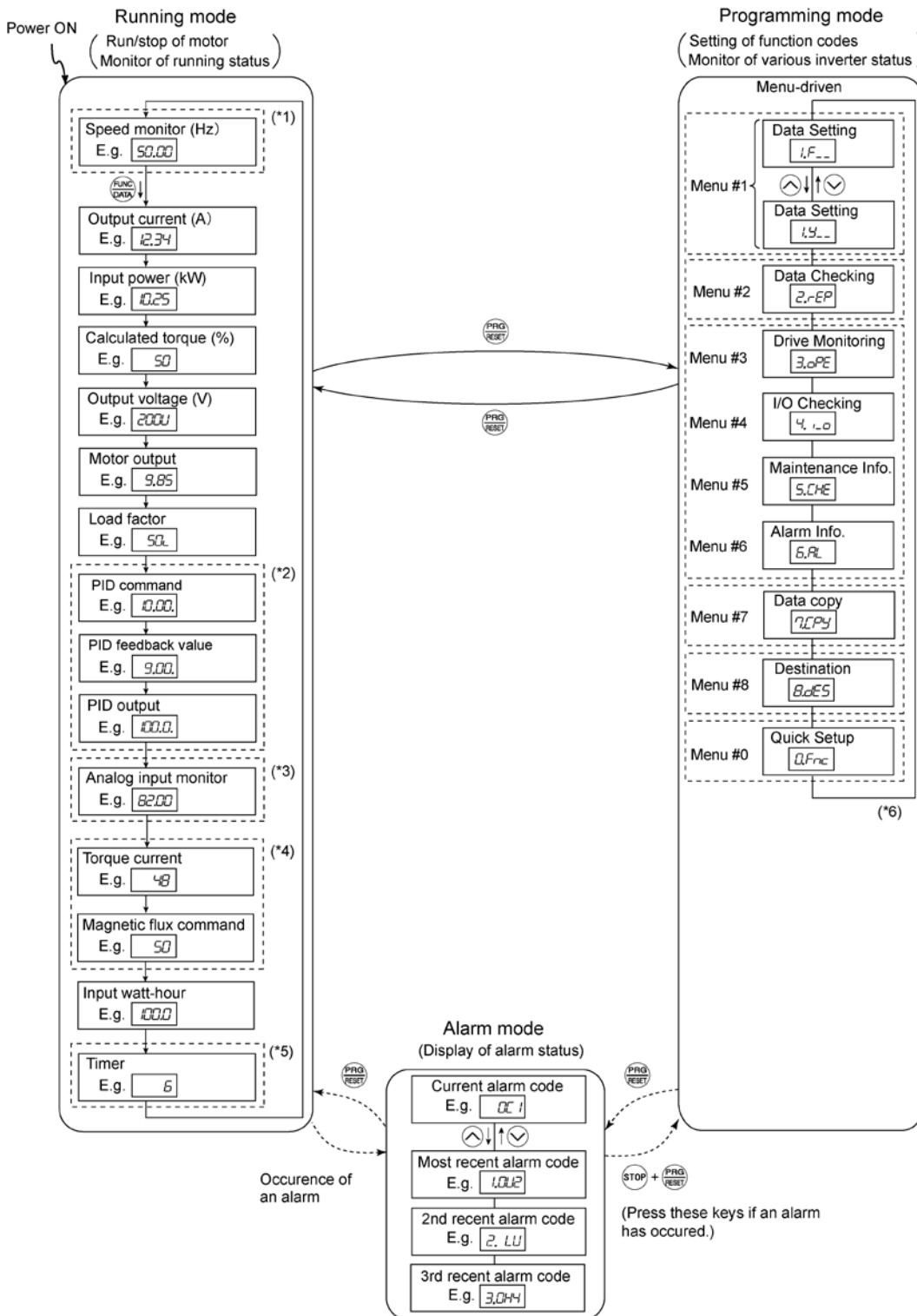

Figure 3.2-2 Transition between Basic Screens in Individual Operation Mode

- (*1) The speed monitor allows you to select the desired one from the speed monitor items by using function code E48.
- (*2) Applicable only when PID control is active (J01 = 1, 2 or 3).
- (*3) The analog input monitor can appear only when the analog input monitor function is assigned to one of the analog input terminals by one of function codes E61 to E63 (= 20).
- (*4) □ appears under the V/f control.
- (*5) The Timer screen appears only when the timer operation is enabled with function code C21 (C21 = 1).
- (*6) Applicable only when the full-menu mode is selected (E52 = 2). When a remote keypad with USB is equipped, 7.CPY is displayed.

Chapter 4 TEST RUN PROCEDURE

4.1 Test Run Procedure Flowchart

Make a test run of the motor using the flowchart given below.

This chapter describes the test run procedure with motor 1 dedicated function codes that are marked with an asterisk (*). For motor 2, replace those function codes with asterisk with motor 2 dedicated ones.

 For the function codes dedicated to motor 2, see Chapter 5 "FUNCTION CODES."

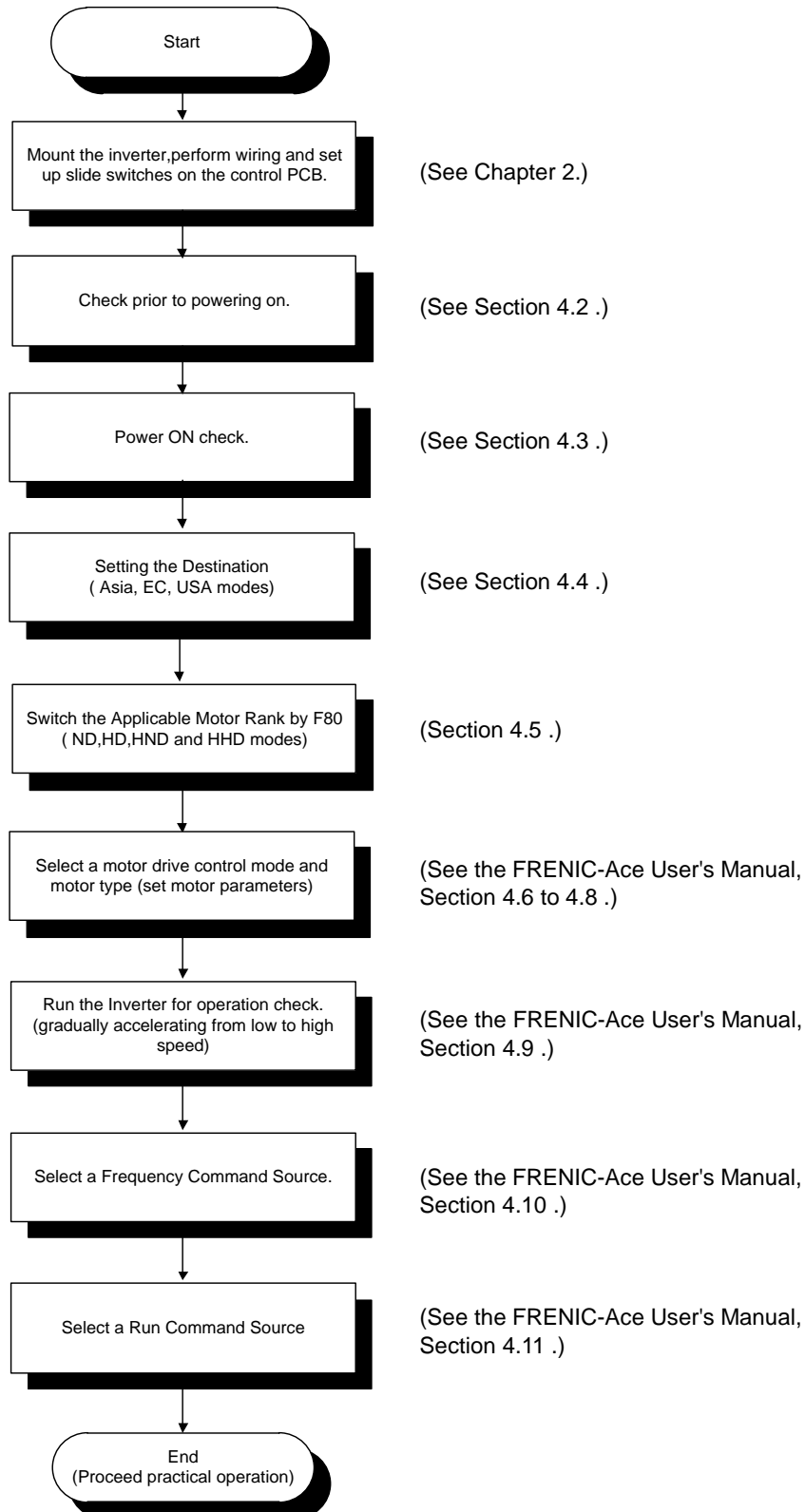

Figure 4.1-1 Test Run Procedure

4.2 Checking Prior to Powering On

Check the following before powering on the inverter.

- (1) Check that the wiring is correct.

Especially check the wiring to the inverter input terminals (L1/R, L2/S, L3/T or L1/L, L2/N) and output terminals (U, V, and W). Also check that the grounding wires are connected to the grounding terminals (⊕G) correctly. See Figure 4.2-1.

⚠ WARNING

- Never connect power supply wires to the inverter output terminals U, V, and W. Doing so and turning the power ON breaks the inverter.
- Be sure to connect the grounding wires of the inverter and the motor to the ground electrodes.

Otherwise, an electric shock could occur.

- (2) Check the control circuit terminals and main circuit terminals for short circuits or ground faults.
- (3) Check for loose terminals, connectors and screws.
- (4) Check that the motor is separated from mechanical equipment.
- (5) Make sure that all switches of devices connected to the inverter are turned OFF. Powering on the inverter with any of those switches being ON may cause an unexpected motor operation.
- (6) Check that safety measures are taken against runaway of the equipment, e.g., a defense to prevent people from access to the equipment.
- (7) Check that a power factor correction DC reactor (DCR) is connected to the DC reactor terminals P1 and P(+). (ND-mode in case of inverters FRN0139E2■-4□ or above, HD-/HND-mode in case of FRN0168E2■-4□ or above, and HHD-mode in case of FRN0203E2■-4□ or above must be used with a DCR. Be sure to connect the DCR to the inverter.)

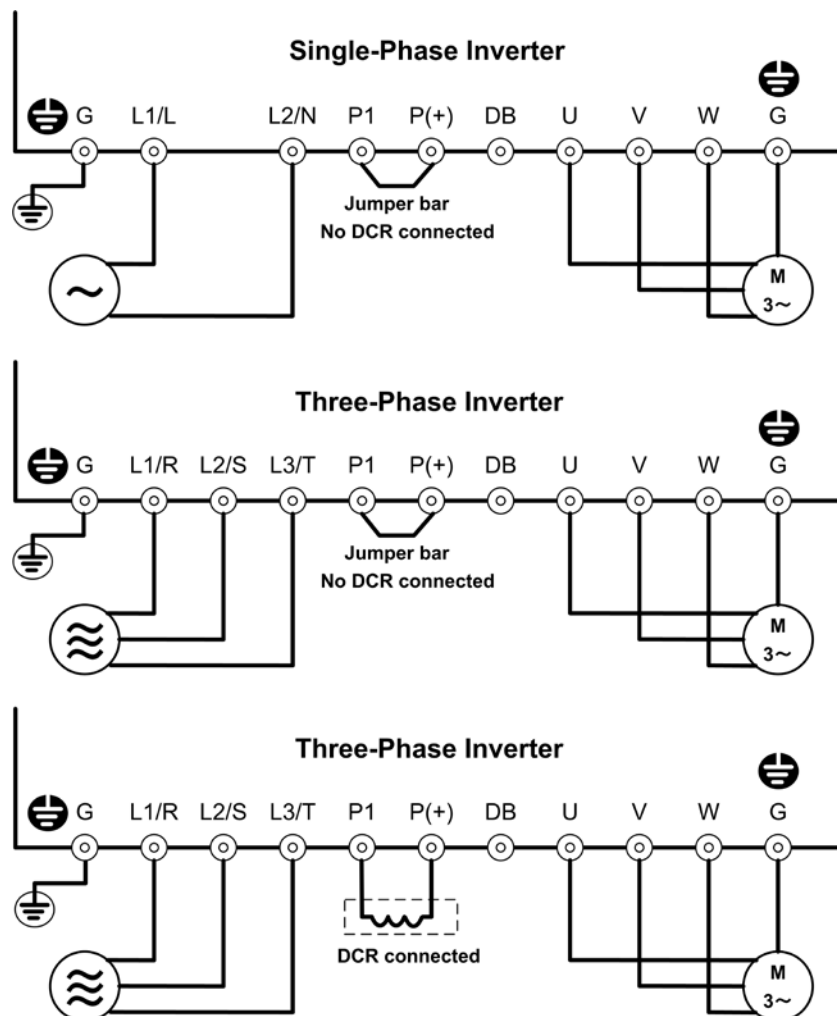

Figure 4.2-1 Connection of Main Circuit Terminals

4.3 Powering ON and Checking

⚠ WARNING

- Be sure to mount the front cover before turning the power ON. Do not remove the cover when the inverter power is ON.
- Do not operate switches with wet hands.

Otherwise, an electric shock could occur.

Turn the power ON and check the following points. The following is a case when no function code data is changed from the factory defaults.

- (1) Check that the LED monitor displays *8.0ES* (indicating that the destination is not set) that is blinking. See Figure 4.3-1.
- (2) Check that the inverter (built-in) cooling fans rotate.



Figure 4.3-1 Display of the LED Monitor after Power-on

4.4 Destination setting

For inverter type FRN****E2S/E2E-2G□/4G□/7G□ (FRENIC-Ace Global Model), the destination must be set first after the initial power supply. Without setting the destination, the function code cannot be changed. The inverter cannot be operated either. By setting the destination, basic function codes such as rated voltage, rated frequency, etc. are initialized to general values in each region (Table 4.4-1). If the destination value setting is changed after the initial destination setting, it can be changed with *EdES* in the program mode menu or function code H101. If the destination is reset by *EdES*, all function codes are initialized to the factory defaults. If the destination is set by H101, only the function codes in Table 4.4-1 are initialized to the values in Table 4.4-1. The destination can be selected from the regions of Japan, Asia, China, Europe, Americas and Korea.

If the function code set including the destination setting function code (H101) is copied with the data copy function or the FRENIC loader, manual destination setting is not required.

Set the initial destination as shown below. Refer to Figure 4.4-1 on the page 4-5.





- (1) With *EdES* displayed, press  key first.
- (2) *AS A* (Asian region) is displayed first. For other regions, while pressing  key and press  key or  key to select the destination.
- (3) After selecting the destination, *SPUE* is displayed by pressing  key and the destination setting is completed. Then, *□. □□* is displayed.

Table 4.4-1 Initial value for each destination

Destination	Asia	China	Europe	Americas	Korea	Japan
LED display	asia	chn	eU	amer	kor	jpn
H101:Destination	2	3	4	5	7	1
F03:Maximum output frequency 1	60.0Hz (200V)	50.0Hz	50.0Hz	60.0Hz	60.0Hz	60.0Hz
F04:Base frequency 1	50.0Hz (400V)					50.0Hz
F05:Rated voltage at base frequency 1	220/415V	200/380V	200/400V	230/460V	220/380V	200/400V
F06:Maximum output voltage 1						
F14:Restart mode after momentary power failure (Mode selection)	1	1	0	0	1	1
F44:Current limiter (Level)	130%	130%	130%	130%	130%	180/160%
E31:Frequency detection 1 (Level)	60.0Hz (200V) 50.0Hz (400V)	50.0Hz	50.0Hz	60.0Hz	60.0Hz	60.0Hz
E36:Frequency detection 2 (Level)						50.0Hz
E54:Frequency detection 3 (Level)						
P99:Motor 1 selection	0	0	0	1	0	0
H96:STOP key priority/ Start check function	0	0	0	3	0	0
A01:Maximum output frequency 2	60.0Hz (200V)	50.0Hz	50.0Hz	60.0Hz	60.0Hz	60.0Hz
A02:Base frequency 2	50.0Hz (400V)					50.0Hz
A03:Rated voltage at base frequency 2	220/415V	200/380V	200/400V	230/460V	220/380V	200/400V
A04:Maximum output voltage 2						
A39:Motor 2 selection	0	0	0	1	0	0
K01:Multifunction keypad TP-A1 (Language selection)	1	6	1	1	1	0

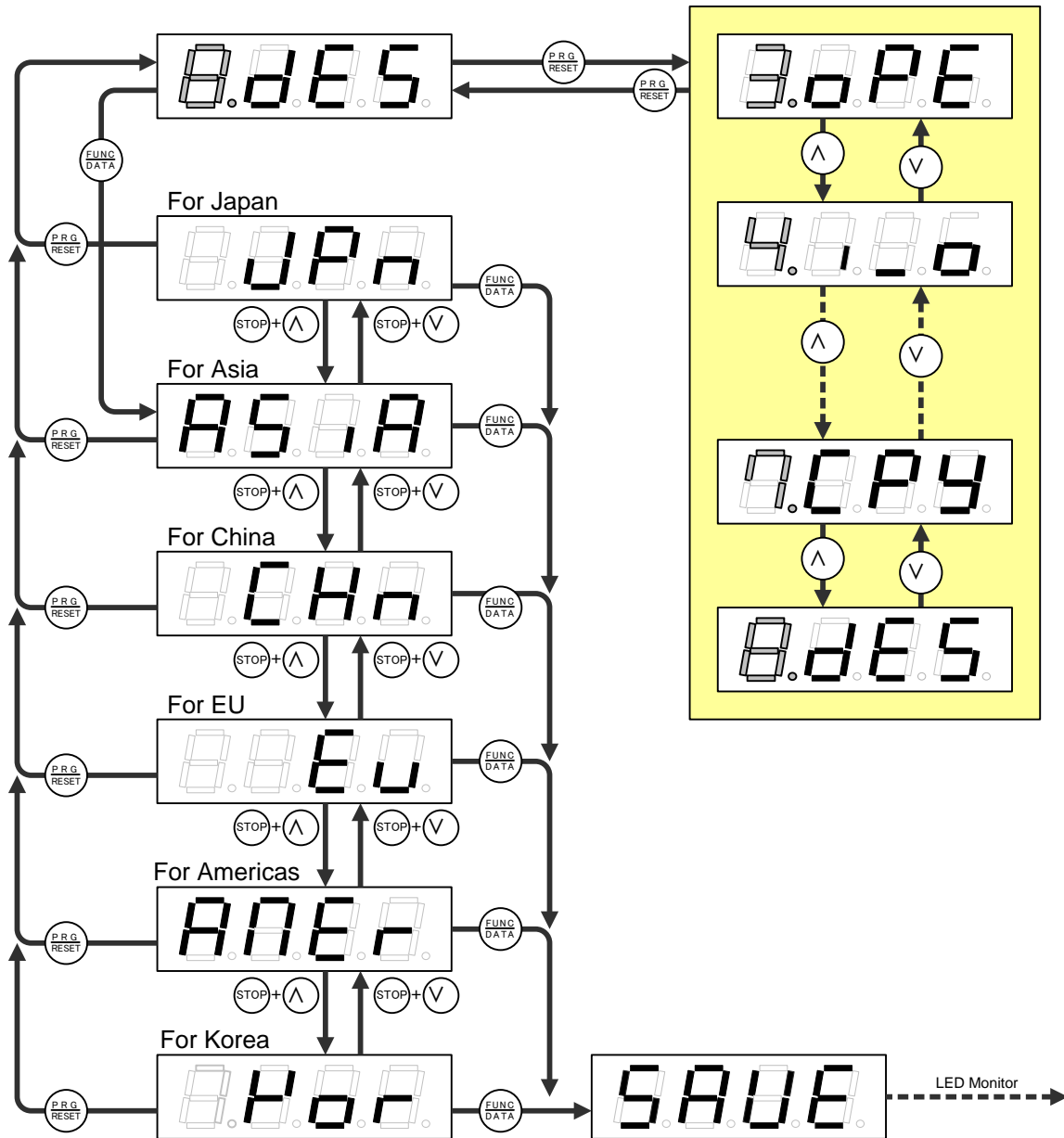

Figure 4.4-1 Destination setting status transition chart

4.5 Switching the Applicable Motor Rating (ND, HD, HND and HHD Modes)

Changing the data of function code F80 switches the applicable motor rank to match load conditions. In HD, HND or HHD mode, the inverter drives a motor whose capacity is one or two ranks lower than the inverter's one.

F80 data	Drive mode	Application	Applicable motor	Overload capability	Maximum frequency	Operating temperature	Application samples
4	ND mode	General load	Motor whose capacity is the same as the inverter's one.	120% for 1 min.	120 Hz	40°C (104°F)	Fan, pump, blower, compressor, etc.
3	HD mode	Heavy duty load	Motor whose capacity is one rank lower than the inverter's one.	150% for 1 min.	500 Hz	40°C (104°F)	Wire drawing machine, winding machine, twisting machine, spinning frame, etc.
1	HND mode	General load	Motor whose capacity is one rank lower than the inverter's one.	120% for 1 min.	500 Hz	50°C (122°F)	Fan, pump, blower, compressor, etc.
0	HHD mode	Heavy duty load	Motor whose capacity is two ranks lower than the inverter's one.	150% for 1 min. 200% for 0.5 s.	500 Hz	50°C (122°F)	Wire drawing machine, winding machine, twisting machine, spinning frame, hoist, machine tool, etc.

The HD-/HND-/HHD-mode inverter brings out the continuous rated current level which enables the inverter to drive a motor with one or two ranks lower capacity, but its overload capability (%) against the continuous current level or the operating temperature increases. For details, see Chapter 12 "SPECIFICATIONS."

Three-phase 400V series inverters have an ND/HD/HND/HHD four type rating. However, the FRN0007E2■-4□ and FRN0012E2■-4□ have an ND/HD/HHD three type rating.

Three-phase 200V series inverters have an HND/HHD two type rating. However, the FRN0012E2■-2□ and FRN0020E2■-2□ have an ND/HND two type rating.

Single-phase 200V series inverters have only an HHD single rating.

4.5 Switching the Applicable Motor Rating (ND, HD, HND and HHD Modes)

The inverter is subject to restrictions on the function code data setting range and internal processing as listed below.

Function codes	Name	ND mode	HD mode	HND mode	HHD mode	Remarks
F21*	DC braking (Braking level)	Setting range: 0 to 60%	Setting range: 0 to 80%		Setting range: 0 to 100%	
F26	Motor sound (Carrier frequency)	ND mode - 0.75 to 10 kHz (FRN0002E2■-4□ to FRN0059E2■-4□) - 0.75 to 10 kHz (FRN0012E2■-2□ to FRN0020E2■-2□) - 0.75 to 6 kHz (FRN0072E2■-4□ or above) HD/HND mode - 0.75 to 16 kHz (FRN0001E2■-2□ to FRN0088E2■-2□) - 0.75 to 16 kHz (FRN0002E2■-4□ to FRN0059E2■-4□) - 0.75 to 10 kHz (FRN0072E2■-4□ to FRN0168E2■-4□) - 0.75 to 10 kHz (FRN0115E2■-2□) - 0.75 to 6 kHz (FRN0203E2■-4□ or above) HHD mode - 0.75 to 16 kHz (FRN0001E2■-2□ to FRN0115E2■-2□) - 0.75 to 16 kHz (FRN0001E2■-7□ to FRN0011E2■-7□) - 0.75 to 16 kHz (FRN0002E2■-4□ to FRN0168E2■-4□) - 0.75 to 10 kHz (FRN0203E2■-4□ or above)				In the ND/HD/HND mode, a value out of the range, if specified, automatically changes to the maximum value allowable in the ND/HD/HND mode.
F44	Current limiter (Level)	Initial value: 130%	Initial value: 160%	Initial value: 130%	Initial value: FRN0088E2■-2□/ FRN0059E2■-4□ or above : 160% FRN0069E2■-2□/ FRN0044E2■-4□ or below : 180%	Switching the drive mode with function code F80 automatically initializes the F44 data to the value specified at left.
F03*	Maximum frequency	Setting range: 25 to 500 Hz Upper limit: 120 Hz	Setting range: 25 to 500 Hz Upper limit: 500 Hz			In the ND mode, if the maximum frequency exceeds 120 Hz, the actual output frequency is internally limited to 120 Hz.
—	Current indication and output	Based on the rated current level for ND mode	Based on the rated current level for HD mode	Based on the rated current level for HND mode	Based on the rated current level for HHD mode	—

Switching between the drive modes does not automatically change the motor rated capacity (P02*) to the one suitable for the rank-changed motor, so configure the P02* data to match the applied motor rating as required.

Chapter 5 FUNCTION CODES

5.1 Function Codes Overview







Function codes are used for selecting various functions of FRENIC-Ace. Function codes comprise 3 digits or 4 digits of alphanumeric character. The first digit categorizes the group of function code alphabetically and the subsequent 2 or 3 digits identify each code within the group by number. Function code comprises 11 groups: Basic function (F code), Terminal function (E code), Control code (C code), Motor 1 parameter (P code), High-level function (H code) (H1 code), Motor 2 parameter (A code), Application function 1 (J code) (J1 code), Application function 2 (d code), Customizable logic (U code) (U1 code), Link function (y code), Keypad functions (K code), and and Option function (o code). The function of each function code is determined according to the data to be set. The following descriptions are for supplementary explanation of function code table. Refer to instruction manual of each option to find the details of the option function (o code).

5.2 Function Codes Table

5.2.1 Supplementary note

■ Change, reflect, and save function code data during operation

Function codes are categorized into those which data change is enabled during operation of the inverter and those which such change is disabled. The meaning of the code in the “Change during operation” column of the function code table is described in the following table.

Code	Change during operation	Reflect and save data
Y*	Allowed	At the point when data is changed by  key, the changed data is immediately reflected on the operation of inverter. However, at this stage, the changed value is not saved to the inverter. In order to save it to the inverter, press  key. Without saving by  key and leaving the state of when the change was made by the  key, the data before the change is reflected on the operation of inverter.
Y	Allowed	Even if data is changed by the  key, the changed data will not be reflected on the operation of the inverter as is; by pressing the  key, the changed value is reflected on the operation of the inverter and is also saved to the inverter.
N	Not allowed	—

■ Copying data

Function code data can be copied collectively by using the optional keypad “TP-E1U” (program mode menu number 7 “Data copy”). By using this function, it is possible to read out all function code data and write the same data to a different inverter.

However, if the specification of inverter at the copy source and copy destination is not identical, some function codes may not be copied due to security reason. According to necessity, configure the settings individually for the function codes that are not copied. The behaviour of the function codes regarding data copy is indicated in the “data copy” column in the function code table in the next page and following.

- Y: to be copied.
- Y1: When inverter capacity is different, copying will not be performed.
- Y2: When voltage group is different, copying will not be performed.
- N: not to be copied.

■ Negative logic setting of data

Digital input terminal and transistor/contact output terminal can become a signal for which negative logic is specified by function code data setting. Negative logic is a function to reverse ON and OFF state of input or output, and switch Active ON (function enabled with ON: positive logic) and Active OFF (function enabled with OFF: negative logic). However, negative logic may not be enabled depending on the function of the signal.

Negative logic signal can be switched by setting the data with 1000 added to the function code data of the function to be set. For example, the following example shows when coast to a stop command "BX" is selected by function code E01.

Function code data	Action
7	"BX" is ON and coast to a stop (Active ON)
1007	"BX" is OFF and coast to a stop (Active OFF)

■ Drive control

The FRENIC-Ace runs under any of the following drive controls. Some function codes apply exclusively to the specific drive control, which is indicated by letters Y (Applicable) and N (Not applicable) in the "Drive control" column in the function code tables given on the following pages.

Abbreviation in "Drive control" column in function code tables	Control target (H18)	Drive control (F42)
V/f	Speed (Frequency for V/f and PG V/f)	0,2: V/f control 1: Dynamic torque vector control
PG V/f		3: V/f control with speed sensor 4: V/f control with speed sensor and auto torque boost
w/ PG		6: Vector control with speed sensor
Torque control	Torque	6: Vector control with speed sensor
PM	Speed	15: Vector control without speed sensor nor pole position sensor

For details about the drive control, refer to the description of the FRENIC-Ace User's Manual, F42 "Drive control selection 1."

Note The FRENIC-Ace is a general-purpose inverter whose operation is customized by frequency-basis function codes, like conventional inverters. Under the speed-basis drive control, however, the control target is a motor speed, not a frequency, so convert the frequency to the motor speed according to the following expression.

$$\text{Motor speed (r/min)} = 120 \times \text{Frequency (Hz)} \div \text{Number of poles}$$

5.2.2 Function codes table

The table of function codes to be used in FRENIC-Ace is shown below.
The related page shows the page of the user's manual.

■ F codes: Fundamental Functions (Basic function)

Code	Name	Data setting range	Change when running	Data copying	Factory Default	Drive control					Related page
						V/f	PG V/f	w/ PG	Torque control	PM	
F00	Data protection	0: No data protection, no digital setting protection 1: With data protection, no digital setting protection 2: No data protection, with digital setting protection 3: With data protection, with digital setting protection	Y	Y	0	Y	Y	Y	Y	Y	5-45
F01	Frequency setting 1	0: Keypad key operation (⏏/⏏key) 1: Analog voltage input (Terminal [12]) (from 0 to ±10 VDC) 2: Analog current input (Terminal [C1] (C1 function)) (4 to 20mA DC, 0 to 20mA DC) 3: Analog voltage input (Terminal [12]) + Analog current input (Terminal [C1] (C1 function)) 5: Analog voltage input (Terminal [C1] (V2 function)) (0 to 10 VDC) 7: UP/DOWN control 8: Keypad key operation (⏏/⏏key) (With balanceless bumpless) 10: Pattern operation 11: Digital input/output interface card (option) *5 12: Pulse train input	N	Y	0	Y	Y	Y	N	Y	5-46
F02	Operation method	0: Keypad operation (rotation direction input: terminal block) 1: External signal (digital input) 2: Keypad operation (forward rotation) 3: Keypad operation (Reverse rotation)	N	Y	2	Y	Y	Y	Y	Y	5-57
F03	Maximum output frequency 1	25.0 to 500.0 Hz	N	Y	200V class AJKU:60.0 400V class ACE:50.0 JKU:60.0	Y	Y	Y	Y	Y	5-58
F04	Base frequency 1	25.0 to 500.0Hz	N	Y	200V class J:50.0 AUK:60.0 400V class ACEJ:50.0 UK:60.0	Y	Y	Y	Y	Y	5-59
F05	Rated voltage at base frequency 1	0: AVR disable (output voltage proportional to power voltage) 80 to 240 V : AVR operation (200V class) 160 to 500V : AVR operation (400V class)	N	Y2	200V class J:200 AK:220 U:230	Y	Y	Y	Y	Y	
F06	Maximum output voltage 1	80 to 240V : AVR operation (200V class) 160 to 500V : AVR operation (400V class)	N	Y2	400V class EJ:400 A:415 CK:380 U:460	Y	Y	N	Y	Y	
F07	Acceleration time1	0.00 to 6000 s	Y	Y	6.00	Y	Y	Y	N	Y	5-61
F08	Deceleration time1	* 0.00 is for acceleration and deceleration time cancel (when performing soft-start and stop externally)	Y	Y	or 20.0 *10	Y	Y	Y	N	Y	
F09	Torque boost 1	0.0 to 20.0% (% value against base frequency voltage 1)	Y	Y	*2	Y	Y	N	N	N	5-63
F10	Electronic thermal overload protection for motor 1 (Select motor characteristics)	1: Enable (For a general-purpose motor with self-cooling fan) 2: Enable (For an inverter-driven motor (FV) with separately powered cooling fan)	Y	Y	1	Y	Y	Y	Y	Y	5-63
F11	(Overload detection level)	0.00 (disable), current value of 1 to 135% of inverter rated current (Inverter rated current dependent on F80)	Y	Y1 Y2	*3	Y	Y	Y	Y	Y	
F12	(Thermal time constant)	0.5 to 75.0 min	Y	Y	*4	Y	Y	Y	Y	Y	

Factory default...A (For Asia), C (for China), E (for Europe), U (For USA), J (for Japan), K (for Korea)

■ indicates quick setup target function code.

*2: Factory defaults are depended on motor capacity. Refer to "5.2.3 Factory default value per applicable electric motor capacitance".

*3: The motor rated current is automatically set. Refer to the FRENIC-Ace User's Manual, "5.2.4 Motor constant".

*4: 5.0min for inverters of nominal applied motor 22kW or below; 10.0min for those of 30kW or above.

*5: Available at ROM version 0300 or later.

*10:6.00s for inverters of nominal applied motor 22kW or below; 20.0s for those of 30kW or above.

5.2 Function Codes Table

Code	Name	Data setting range	Change when running	Data copying	Factory Default	Drive control					Related page
						V/f	PG V/f	w/PG	Torque control	PM	
F14	Restart mode after momentary power failure (Mode selection)	0: Trip immediately 1: Trip after a recovery from power failure 2: Trip after momentary deceleration is stopped 3: Continue to run (for heavy inertia load or general load) 4: Restart from frequency at power failure (for general load) 5: Restart from starting frequency	Y	Y	EU: 0 ACJK:1	Y	Y	Y	N	Y	5-66
F15	Frequency limiter (Upper limit)	0.0 to 500.0Hz	Y	Y	70.0	Y	Y	Y	N	Y	5-73
F16	(Lower limit)	0.0 to 500.0Hz	Y	Y	0.0	Y	Y	Y	N	Y	
F18	Bias (for frequency setting 1)	-100.00 to 100.00%	Y*	Y	0.00	Y	Y	Y	N	Y	5-73
F20	DC braking 1 (Braking starting frequency)	0.0 to 60.0Hz	Y	Y	0.0	Y	Y	Y	N	Y	5-74
F21	(Braking level)	0 to 100% (HHD mode), 0 to 80% (HD/HND mode) 0 to 60% (ND mode)	Y	Y	0	Y	Y	Y	N	Y	
F22	(Braking time)	0.00 (Disable): 0.01 to 30.00 s	Y	Y	0.00	Y	Y	Y	N	Y	
F23	Starting frequency 1	0.0 to 60.0Hz	Y	Y	0.5	Y	Y	Y	N	Y	5-77
F24	(Holding time)	0.00 to 10.00 s	Y	Y	0.00	Y	Y	Y	N	Y	
F25	Stop frequency	0.0 to 60.0 Hz	Y	Y	0.2	Y	Y	Y	N	Y	
F26	Motor sound (Carrier frequency)	ND mode - 0.75 to 10 kHz (FRN0002 to 0059E2■-4□) - 0.75 to 6 kHz (FRN0072E2■-4□ or above) HD/HND mode - 0.75 to 16 kHz (FRN0001 to 0088E2■-2□) - 0.75 to 16 kHz (FRN0002 to 0059E2■-4□) - 0.75 to 16 kHz (FRN0001 to 0012E2■-7□) - 0.75 to 10 kHz (FRN0072 to 0168E2■-4□) - 0.75 to 10 kHz (FRN0115E2■-2□) - 0.75 to 6 kHz (FRN0203E2■-4□ or above) HHD mode - 0.75 to 16 kHz (FRN0001 to 0115E2■-2□) - 0.75 to 16 kHz (FRN0002 to 0168E2■-4□) - 0.75 to 16 kHz (FRN0001 to 0012E2■-7□) - 0.75 to 10 kHz (FRN0203E2■-4□ or above)	Y	Y	2	Y	Y	Y	Y	Y	5-80
F27	(Tone)	0: Level 0 (Disable) 1 to 3 : Level 1 to 3	Y	Y	0	Y	Y	N	N	N	
F29	Terminal FM (Mode selection)	0: Voltage output (0 to +10 VDC) 1: Current output (4 to 20 mA DC) 2: Current output (0 to 20 mA DC) 3: Pulse output	Y	Y	0	Y	Y	Y	Y	Y	5-81
F30	(Output gain)	0 to 300%	Y*	Y	100	Y	Y	Y	Y	Y	
F31	(Function selection)	0: Output frequency 1 (before slip compensation) 1: Output frequency 2 (after slip compensation) 2: Output current 3: Output voltage 4: Output torque 5: Load factor 6: Input power 7: PID feedback value 8: Actual speed/estimated speed *5 9: DC link bus voltage 10: Universal AO 13: Motor output 14: Calibration (+) 15: PID command (SV) 16: PID output (MV) 17: Position error in master-follower operation *5 18: Inverter heat sink temperature 21: PG feedback value *5 111 to 120 Customizable logic output signal 1 to 10	Y	Y	0	Y	Y	Y	N	Y	
F32	Terminal FM 2 *1 (Mode selection)	0: Voltage output (0 to +10 VDC) 1: Current output (4 to 20 mA DC) 2: Current output (0 to 20 mA DC)	Y	Y	0	Y	Y	Y	Y	Y	
F33	Terminal FM (Pulse rate)	25 to 32000 p/s (number of pulse at monitor value 100%)	Y*	Y	1440	Y	Y	Y	Y	Y	
F34	Terminal FM 2 *1 (Output gain)	0 to 300%	Y*	Y	100	Y	Y	Y	Y	Y	
F35	(Function selection)	Same as F31	Y	Y	2	Y	Y	Y	N	Y	

Factory default***A (For Asia), C (for China), E (for Europe), U (For USA), J (for Japan), K (for Korea)

■ indicates quick setup target function code.

*1: F34 and F35 only exist for GB model and C model (for China).

*5: Available at ROM version 0300 or later.

5.2 Function Codes Table

Code	Name	Data setting range	Change when running	Data copying	Factory Default	Drive control					Related page
						V/f	PG V/f	w/PG	Torque control	PM	
F37	Load selection/ Auto torque boost/ Auto energy-saving operation 1	0: Variable torque load 1: Constant torque load 2: Auto torque boost 3: Auto energy-saving operation (variable torque load) 4: Auto energy-saving operation (constant torque load) 5: Auto energy-saving operation with auto torque boost	N	Y	1	Y	Y	Y	N	N	5-84
F38	Stop frequency (Detection mode) *5	0: Actual speed / estimated speed 1: Reference speed	N	Y	0	N	N	Y	N	N	5-86
F39	Stop frequency (Holding time)	0.00 to 10.00 s	Y	Y	0.00	Y	Y	Y	N	Y	
F40	Torque limiter 1 (Driving)	0 to 300%; 999 (Disable)	Y	Y	999	Y	Y	Y	Y	Y	5-86
F41	(Braking)	0 to 300%; 999 (Disable)	Y	Y	999	Y	Y	Y	Y	Y	
F42	Drive control selection 1	0: V/f control without slip compensation 1: Vector control without speed sensor (dynamic torque vector) 2: V/f control with slip compensation 3: V/f control with speed sensor *5 4: V/f control with speed sensor and auto torque boost *5 6: Vector control for induction motor with speed sensor *5 15: Vector control for synchronous motor without speed sensor nor pole position sensor *5	N	Y	0	Y	Y	Y	Y	Y	5-92
F43	Current limiter (Mode selection)	0: Disable (No current limiter works.) 1: Enable at constant speed (Disable during ACC/DEC) 2: Enable during ACC/constant speed operation	Y	Y	2	Y	Y	N	N	N	5-96
F44	(Level)	20 to 200% (Rated current of the inverter for 100%)	Y	Y	J:180/160 ACEKU: 130	Y	Y	N	N	N	
F50	Electronic thermal overload protection for braking resistor (Discharging capacity)	1 to 9000 kW OFF (Cancel)	Y	Y1 Y2	OFF	Y	Y	Y	Y	Y	5-97
F51	(Allowable average loss)	0.001 to 99.99 kW	Y	Y1 Y2	0.001	Y	Y	Y	Y	Y	
F52	(Braking resistance value)	0.00: Resistance not required (Compatible mode with FRENIC-Multi series) 0.01 to 999 Ω	Y	Y1 Y2	0.00	Y	Y	Y	Y	Y	
F80	Switching between ND, HD, HND and HHD drive modes	0: HHD mode 1: HND mode 3: HD mode 4: ND mode ND/HD mode is not supported for 200V class series.	N	Y	4	Y	Y	Y	Y	Y	5-99

Factory default***A (For Asia), C (for China), E (for Europe), U (For USA), J (for Japan), K (for Korea)
*5: Available at ROM version 0300 or later.

■ E code: Extension Terminal Functions (Terminal function)

Code	Name	Data setting range	Change when running	Data copying	Factory Default	Drive control					Related page
						V/f	PG V/f	w/ PG	Torque control	PM	
E01	Terminal [X1] function	0 (1000): Select multistep frequency (0 to 1 steps) "SS1"	N	Y	0	Y	Y	Y	N	Y	5-100
E02	Terminal [X2] function	1 (1001): Select multistep frequency (0 to 3 steps) "SS2"	N	Y	1	Y	Y	Y	N	Y	
E03	Terminal [X3] function	2 (1002): Select multistep frequency (0 to 7 steps) "SS4"	N	Y	2	Y	Y	Y	N	Y	
E04	Terminal [X4] function	3 (1003): Select multistep frequency (0 to 15 steps) "SS8"	N	Y	7	Y	Y	Y	N	Y	
E05	Terminal [X5] function	4 (1004): Select ACC/DEC time (2 steps) "RT1"	N	Y	8	Y	Y	Y	N	Y	
		5 (1005): Select ACC/DEC time (4 steps) "RT2"				Y	Y	Y	N	Y	
		6 (1006): Select 3-wire operation "HLD"				Y	Y	Y	N	Y	
		7 (1007): Coast to a stop command "BX"				Y	Y	Y	Y	Y	
		8 (1008): Reset alarm (Abnormal) "RST"				Y	Y	Y	Y	Y	
		9 (1009): External alarm (9 = Active OFF/ 1009 = Active ON) "THR"				Y	Y	Y	Y	Y	
		10 (1010): Ready for jogging "JOG"				Y	Y	Y	N	N	
		11 (1011): Select frequency setting 2/ frequency setting 1 "Hz2/ Hz1"				Y	Y	Y	N	Y	
		12 (1012): Select motor 2 "M2"				Y	Y	Y	Y	Y	
		13: DC braking command "DCBRK"				Y	Y	Y	N	N	
		14 (1014): Select torque limit 2/ torque limit 1 "TL2/ TL1"				Y	Y	Y	Y	Y	
		15: Switch to commercial power (50 Hz) "SW50"				Y	Y	N	N	N	
		16: Switch to commercial power (60 Hz) "SW60"				Y	Y	N	N	N	
		17 (1017): UP command "UP"				Y	Y	Y	N	Y	
		18 (1018): DOWN command "DOWN"				Y	Y	Y	N	Y	
		19 (1019): Allow function code editing (Data change enabled) "WE-KP"				Y	Y	Y	Y	Y	
		20 (1020): Cancel PID control "Hz/PID"				Y	Y	Y	N	Y	
		21 (1021): Switch normal/ inverse operation "IVS"				Y	Y	Y	N	Y	
		22 (1022): Interlock "IL"				Y	Y	Y	Y	Y	
		23 (1023): Cancel torque control *5 "Hz/TRQ"				N	N	N	Y	N	
		24 (1024): Select link operation (RS-485, BUS option) "LE"				Y	Y	Y	Y	Y	
		25 (1025): Universal DI "U-DI"				Y	Y	Y	Y	Y	
		26 (1026): Select auto search for idling motor speed at starting "STM"				Y	Y	N	N	Y	
		30 (1030): Force to stop (30 = Active OFF/1030 = Active ON) "STOP"				Y	Y	Y	Y	Y	
		32 (1032): Pre-excite *5 "EXITE"				N	N	Y	Y	N	
		33 (1033): Reset PID integral and differential terms "PID-RST"				Y	Y	Y	N	Y	
		34 (1034): Hold PID integral term "PID-HLD"				Y	Y	Y	N	Y	
		35 (1035): Select local (Keypad) command "LOC"				Y	Y	Y	Y	Y	
		42 (1042): Activate the limit switch at start point *5 "LS"				Y	Y	N	N	N	
		43 (1043): Start / Reset *5 "S/R"				Y	Y	N	N	N	
		44 (1044): Switch to the serial pulse receiving mode *5 "SPRM"				Y	Y	N	N	N	
		45 (1045): Enter the return mode *5 "RTN"				Y	Y	N	N	N	
		46 (1046): Enable overload stop "OLS"				Y	Y	Y	N	Y	
		47 (1047): Servo lock command *5 "LOCK"				N	N	Y	N	N	
		48: Pulse train input (Only for X5 terminal (E05)) "PIN"				Y	Y	Y	N	Y	
		49 (1049): Pulse train sign (Other than X5 terminal (E01 to E04)) "SIGN"				Y	Y	Y	N	Y	
		59 (1059): Enable battery-driven operation *11 "BATRY/UPS"				Y	Y	Y	N	N	
		60 (1060): Select torque bias1 *5 "TB1"				N	N	Y	N	N	
		61 (1061): Select torque bias2 *5 "TB2"				N	N	Y	N	N	
		62 (1062): Hold torque bias *5 "H-TB"				N	N	Y	N	N	
		65 (1065): Check brake "BRKE"				Y	Y	Y	N	N	
		70 (1070): Cancel line speed control *5 "Hz/LSC"				Y	Y	Y	N	N	

*5: Available at ROM version 0300 or later.

*11: Available at ROM version 0500 or later.

5.2 Function Codes Table

Code	Name	Data setting range	Change when running	Data copying	Factory Default	Drive control					Related page
						V/f	PG V/f	w/PG	Torque control	PM	
		71 (1071): Hold line speed control frequency in the memory *5 "LSC-HLD"				Y	Y	Y	N	N	
		72 (1072): Count the run time of commercial power-driven motor 1 *5 "CRUN-M1"				Y	Y	Y	Y	N	
		73 (1073): Count the run time of commercial power-driven motor 2 *5 "CRUN-M2"				Y	Y	Y	Y	N	
		76 (1076): Select droop control "DROOP"				Y	Y	Y	N	N	
		78 (1078): Select speed control parameter 1 *5 "MPRM1"				N	Y	Y	Y	Y	
		79 (1079): Select speed control parameter 2 *5 "MPRM2"				N	Y	Y	Y	Y	
		80 (1080): Cancel customizable logic "CLC"				Y	Y	Y	Y	Y	
		81 (1081): Clear all customizable logic timers "CLTC"				Y	Y	Y	Y	Y	
		82 (1082): Cancel anti-regenerative control "AR-CCL"				Y	Y	Y	N	Y	
		100: No function assigned "NONE"				Y	Y	Y	Y	Y	
		171 (1171): PID control multistage command 1 "PID-SS1"				Y	Y	Y	N	Y	
		172 (1172): PID control multistage command 2 "PID-SS2"				Y	Y	Y	N	Y	
		* Inside the () is the negative logic signal (OFF at short-circuit)									
E10	Acceleration time2	0.00 to 6000 s	Y	Y	6.00	Y	Y	Y	N	Y	5-116
E11	Deceleration time2	* 0.00 is for acceleration and deceleration time cancel (when performing soft-start and stop externally)	Y	Y	or 20.0	Y	Y	Y	N	Y	
E12	Acceleration time 3		Y	Y	*10	Y	Y	Y	N	Y	
E13	Deceleration time 3		Y	Y		Y	Y	Y	N	Y	
E14	Acceleration time 4		Y	Y		Y	Y	Y	N	Y	
E15	Deceleration time 4		Y	Y		Y	Y	Y	N	Y	
E16	Torque limiter 2 (Driving)	0 to 300%; 999 (Disable)	Y	Y	999	Y	Y	Y	Y	Y	5-116
E17	(Braking)	0 to 300%; 999 (Disable)	Y	Y	999	Y	Y	Y	Y	Y	
E20	Terminal [Y1] function	0 (1000): Inverter running "RUN"	N	Y	0	Y	Y	Y	Y	Y	5-117
E21	Terminal [Y2] function	1 (1001): Frequency (speed) arrival "FAR"	N	Y	7	Y	Y	Y	N	Y	
E27	Terminal [30A/B/C] function (Relay output)	2 (1002): Frequency (speed) detected "FDT"	N	Y	99	Y	Y	Y	Y	Y	
		3 (1003): Under voltage detected (inverter stopped) "LU"				Y	Y	Y	Y	Y	
		4 (1004): Detected torque polarity "B/D"				Y	Y	Y	Y	Y	
		5 (1005): Inverter output limiting "IOL"				Y	Y	Y	Y	Y	
		6 (1006): Auto-restarting after momentary power failure "IPF"				Y	Y	Y	Y	Y	
		7 (1007): Motor overload early warning "OL"				Y	Y	Y	Y	Y	
		8 (1008): Keypad operation enabled "KP"				Y	Y	Y	Y	Y	
		10 (1010): Inverter ready to run "RDY"				Y	Y	Y	Y	Y	
		15 (1015): Switch MC on the input power lines "AX"				Y	Y	Y	Y	Y	
		16 (1016): Pattern operation stage transition "TU"				Y	Y	Y	N	Y	
		17 (1017): Pattern operation cycle completed "TO"				Y	Y	Y	N	Y	
		18 (1018): Pattern operation stage 1 "STG1"				Y	Y	Y	N	Y	
		19 (1019): Pattern operation stage 2 "STG2"				Y	Y	Y	N	Y	
		20 (1020): Pattern operation stage 4 "STG4"				Y	Y	Y	N	Y	
		21 (1021): Frequency (speed) arrival 2 "FAR2"				Y	Y	Y	N	Y	
		22 (1022): Inverter output limiting with delay "IOL2"				Y	Y	Y	Y	Y	
		25 (1025): Cooling fan in operation "FAN"				Y	Y	Y	Y	Y	
		26 (1026): Auto-resetting "TRY"				Y	Y	Y	Y	Y	
		27 (1027): Universal DO "U-DO"				Y	Y	Y	Y	Y	
	28 (1028): Heat sink overheat early warning "OH"				Y	Y	Y	Y	Y		
	29 (1029): Synchronization completed *5 "SY"				N	Y	Y	N	N		
	30 (1030): Lifetime alarm "LIFE"				Y	Y	Y	Y	Y		
	31 (1031): Frequency (speed) detected 2 "FDT2"				Y	Y	Y	Y	Y		
	33 (1033): Reference loss detected "REF OFF"				Y	Y	Y	N	Y		
	35 (1035): Inverter outputting "RUN 2"				Y	Y	Y	Y	Y		
	36 (1036): Overload prevention controlling "OLP"				Y	Y	Y	N	Y		
	37 (1037): Current detected "ID"				Y	Y	Y	Y	Y		
	38 (1038): Current detected 2 "ID2"				Y	Y	Y	Y	Y		
	39 (1039): Current detected 3 "ID3"				Y	Y	Y	Y	Y		

*5: Available at ROM version 0300 or later.

*10:6.00s for inverters of nominal applied motor 22kW or below; 20.0s for those of 30kW or above.

5.2 Function Codes Table

Code	Name	Data setting range	Change when running	Data copying	Factory Default	Drive control					Related page
						V/f	PG V/f	w/PG	Torque control	PM	
		41 (1041): Low current detected "IDL"				Y	Y	Y	Y	Y	
		42 (1042): PID alarm "PID-ALM"				Y	Y	Y	N	Y	
		43 (1043): Under PID control "PID-CTL"				Y	Y	Y	N	Y	
		44 (1044): Under sleep mode of PID control "PID-STP"				Y	Y	Y	N	Y	
		45 (1045): Low torque detected "U-TL"				Y	Y	Y	Y	Y	
		46 (1046): Torque detected 1 "TD1"				Y	Y	Y	Y	Y	
		47 (1047): Torque detected 2 "TD2"				Y	Y	Y	Y	Y	
		48 (1048): Motor 1 selected "SWM1"				Y	Y	Y	Y	Y	
		49 (1049): Motor 2 selected "SWM2"				Y	Y	Y	Y	Y	
		52 (1052): Running forward "FRUN"				Y	Y	Y	Y	Y	
		53 (1053): Running reverse "RRUN"				Y	Y	Y	Y	Y	
		54 (1054): Under remote mode "RMT"				Y	Y	Y	Y	Y	
		56 (1056): Motor overheat detected by thermistor "THM"				Y	Y	Y	Y	Y	
		57 (1057): Brake control "BRKS"				Y	Y	Y	N	N	
		58 (1058): Frequency (speed) detected 3 "FDT3"				Y	Y	Y	Y	Y	
		59 (1059): Terminal [C1] (C1 function) wire break detected "C1OFF"				Y	Y	Y	Y	Y	
		70 (1070): Speed valid *5 "DNZS"				N	Y	Y	Y	Y	
		71 (1071): Speed agreement *5 "DSAG"				N	Y	Y	N	Y	
		72 (1072): Frequency (speed) arrival 3 "FAR3"				Y	Y	Y	N	Y	
		76 (1076): PG error detected *5 "PG-ERR"				N	Y	Y	N	Y	
		77 (1077): Low DC link bus voltage detection "U-EDC"				Y	Y	Y	Y	Y	
		79 (1079): During decelerating at momentary power failure "IPF2"				Y	Y	Y	Y	Y	
		80 (1080): Stop position override alarm *5 "OT"				N	Y	N	N	N	
		81 (1081): Under positioning *5 "TO"				N	Y	N	N	N	
		82 (1082): Positioning completed *5 "PSET"				N	Y	Y	N	N	
		83 (1083): Current position count over-flowed *5 "POF"				N	Y	N	N	N	
		84 (1084): Maintenance timer counted up "MNT"				Y	Y	Y	Y	Y	
		87 (1087): Frequency arrival and detected "FARFDT"				Y	Y	Y	N	Y	
		90 (1090): Alarm content 1 "AL1"				Y	Y	Y	Y	Y	
		91 (1091): Alarm content 2 "AL2"				Y	Y	Y	Y	Y	
		92 (1092): Alarm content 4 "AL4"				Y	Y	Y	Y	Y	
		93 (1093): Alarm content 8 "AL8"				Y	Y	Y	Y	Y	
		98 (1098): Light alarm "L-ALM"				Y	Y	Y	Y	Y	
		99 (1099): Alarm output "ALM"				Y	Y	Y	Y	Y	
		101 (1101): EN circuit failure detected "DECF"				Y	Y	Y	Y	Y	
		102 (1102): EN terminal input OFF "ENOFF"				Y	Y	Y	Y	Y	
		105 (1105): Braking transistor broken "DBAL"				Y	Y	Y	Y	Y	
		111 (1111): Customizable logic output signal 1 "CLO1"				Y	Y	Y	Y	Y	
		112 (1112): Customizable logic output signal 2 "CLO2"				Y	Y	Y	Y	Y	
		113 (1113): Customizable logic output signal 3 "CLO3"				Y	Y	Y	Y	Y	
		114 (1114): Customizable logic output signal 4 "CLO4"				Y	Y	Y	Y	Y	
		115 (1115): Customizable logic output signal 5 "CLO5"				Y	Y	Y	Y	Y	
		116 (1116): Customizable logic output signal 6 "CLO6"				Y	Y	Y	Y	Y	
		117 (1117): Customizable logic output signal 7 "CLO7"				Y	Y	Y	Y	Y	
		118 (1118): Customizable logic output signal 8 "CLO8"				Y	Y	Y	Y	Y	
		119 (1119): Customizable logic output signal 9 "CLO9"				Y	Y	Y	Y	Y	
		120 (1120): Customizable logic output signal 10 "CLO10"				Y	Y	Y	Y	Y	
		* Inside the () is written the negative logic signal setting (OFF at short-circuit)									
E29	Frequency arrival delay timer (FAR2)	0.01 to 10.00 s	Y	Y	0.10	Y	Y	Y	N	Y	5-126
E30	Frequency arrival detection width (Detection width)	0.0 to 10.0 Hz	Y	Y	2.5	Y	Y	Y	N	Y	

*5: Available at ROM version 0300 or later.

5.2 Function Codes Table

Code	Name	Data setting range	Change when running	Data copying	Factory Default	Drive control					Related page
						V/f	PG V/f	w/PG	Torque control	PM	
E31	Frequency detection 1 (Level)	0.0 to 500.0 Hz	Y	Y	200V class AJKU:60.0 400V class ACE:50.0 JKU:60.0	Y	Y	Y	N	Y	5-128
E32	(Hysteresis width)	0.0 to 500.0 Hz	Y	Y	1.0	Y	Y	Y	N	Y	
E34	Overload early warning/Current detection (Level)	0.00 (Disable), 1 to 200% of inverter rated current (Inverter rated current dependent on F80)	Y	Y1 Y2	*3	Y	Y	Y	Y	Y	5-129
E35	(Timer)	0.01 to 600.00 s	Y	Y	10.00	Y	Y	Y	Y	Y	
E36	Frequency detection 2 (Level)	0.0 to 500.0 Hz	Y	Y	200V class AJKU:60.0 400V class ACE:50.0 JKU:60.0	Y	Y	Y	Y	Y	5-130
E37	Current detection 2/ Low current detection (Level)	0.00 (Disable), 1 to 200% of inverter rated current (Inverter rated current dependent on F80)	Y	Y1 Y2	*3	Y	Y	Y	Y	Y	5-130
E38	(Timer)	0.01 to 600.00 s	Y	Y	10.00	Y	Y	Y	Y	Y	
E39	Display coefficient for transport time	0.000 to 9.999	Y	Y	0.000	Y	Y	Y	N	Y	5-130
E42	LED display filter	0.0 to 5.0 s	Y	Y	0.5	Y	Y	Y	Y	Y	5-130
E43	LED monitor (Item selection)	0: Speed monitor (Selectable with E48) 3: Output current 4: Output voltage 8: Calculated torque 9: Input power 10: PID process command 12: PID feedback value 13: Timer value(for timed operation) 14: PID output 15: Load factor 16: Motor output 17: Analog signal input monitor 21: Current position pulse *5 22: Position error pulse *5 23: Torque current (%) *5 24: Magnetic flux command(%) *5 25: Input watt-hour	Y	Y	0	Y	Y	Y	Y	Y	5-131
E44	(Display when stopped)	0: Specified value 1: Output value	Y	Y	0	Y	Y	Y	Y	Y	
E48	LED monitor (Speed monitor item)	0: Output frequency 1 (before slip compensation) 1: Output frequency 2 (after slip compensation) 2: Reference frequency 3: Motor rotation speed 4: Load rotation speed 5: Line speed 6: Transport time for specified length 7: Speed (%)	Y	Y	0	Y	Y	Y	Y	Y	5-132
E49	Torque Command Monitor *5 (Polarity selection)	0: Torque polarity 1: Plus for driving, Minus for braking	Y	Y	1	Y	Y	Y	Y	Y	5-132
E50	Display coefficient for speed monitor	0.01 to 200.00	Y	Y	30.00	Y	Y	Y	Y	Y	5-133
E51	Display coefficient for "Input watt-hour data"	0.000 (Cancel/Reset). 0.001 to 9999	Y	Y	0.010	Y	Y	Y	Y	Y	5-133
E52	Keypad (Menu display mode)	0: Function code data setting mode (Menu 0, Menu1, and Menu 7) 1: Function code data check mode (Menu 2 and Menu 7) 2: Full-menu mode	Y	Y	0	Y	Y	Y	Y	Y	5-134
E54	Frequency detection 3 (Level)	0.0 to 500.0Hz	Y	Y	200V class J:50.0 AUK:60.0 400V class ACEJ:50.0 UK:60.0	Y	Y	Y	Y	Y	5-134
E55	Current detection 3 (Level)	0.00 (Disable), 1 to 200% of inverter rated current (Inverter rated current dependent on F80)	Y	Y1 Y2	*3	Y	Y	Y	Y	Y	5-134
E56	(Timer)	0.01 to 600.00 s	Y	Y	10.00	Y	Y	Y	Y	Y	

Factory default***A (For Asia), C (for China), E (for Europe), U (For USA), J (for Japan), K (for Korea)

E52 indicates quick setup target function code.

*3: The motor rated current is automatically set. Refer to Refer to the FRENIC-Ace User's Manual, "5.2.4 Motor constant" (function code P03).

*5: Available at ROM version 0300 or later.

5.2 Function Codes Table

Code	Name	Data setting range	Change when running	Data copying	Factory Default	Drive control					Related page
						V/f	PG V/f	w/PG	Torque control	PM	
E59	Terminal [C1] function selection	0: Current input (C1 function) 1: Voltage input (V2 function)	N	Y	0	Y	Y	Y	Y	Y	5-135
E61	Terminal [12] extended function	0: None	N	Y	0	Y	Y	Y	Y	Y	5-136
E62	Terminal [C1] (C1 extended function)	1: Auxiliary frequency setting 1 2: Auxiliary frequency setting 2 3: PID process command 5: PID feedback value	N	Y	0	Y	Y	Y	Y	Y	
E63	Terminal [C1] (V2 extended function)	6: Ratio setting 7: Analog torque limiter A 8: Analog torque limiter B 9: Torque bias *5 10: Torque command *5 11: Torque current command *5 17: Speed limit for forward rotation *5 18: Speed limit for reverse rotation *5 20: Analog signal input monitor	N	Y	0	Y	Y	Y	Y	Y	
E64	Saving of digital reference frequency	0: Auto saving (main power is turned off) 1: Save by turning  key ON	Y	Y	0	Y	Y	Y	Y	Y	5-136
E65	Reference loss detection	0: Stop deceleration 20 to 120%, 999: Cancel	Y	Y	999	Y	Y	Y	N	Y	5-137
E76	DC link bus low-voltage detection level	200 to 400 V (200 V class) 400 to 800 V (400 V class)	Y	Y	235 470	Y	Y	Y	Y	Y	5-137
E78	Torque detection 1 (Level)	0 to 300%	Y	Y	100	Y	Y	Y	Y	Y	5-138
E79	(Timer)	0.01 to 600.00 s	Y	Y	10.00	Y	Y	Y	Y	Y	
E80	Torque detection 2/ low torque detection (Level)	0 to 300%	Y	Y	20	Y	Y	Y	Y	Y	
E81	(Timer)	0.01 to 600.00 s	Y	Y	20.00	Y	Y	Y	Y	Y	
E98	Terminal [FWD] function	0 (1000): Select multistep frequency (0 to 1 steps) "SS1"	N	Y	98	Y	Y	Y	N	Y	5-138
E99	Terminal [REV] function	1 (1001): Select multistep frequency (0 to 3 steps) "SS2"	N	Y	99	Y	Y	Y	N	Y	
		2 (1002): Select multistep frequency (0 to 7 steps) "SS4"				Y	Y	Y	N	Y	
		3 (1003): Select multistep frequency (0 to 15 steps) "SS8"				Y	Y	Y	N	Y	
		4 (1004): Select ACC/DEC time (2 steps) "RT1"				Y	Y	Y	N	Y	
		5 (1005): Select ACC/DEC time (4 steps) "RT2"				Y	Y	Y	N	Y	
		6 (1006): Select 3-wire operation "HLD"				Y	Y	Y	N	Y	
		7 (1007): Coast to a stop command "BX"				Y	Y	Y	Y	Y	
		8 (1008): Reset alarm (Abnormal) "RST"				Y	Y	Y	Y	Y	
		9 (1009): External alarm (9 = Active OFF/1009 = Active ON) "THR"				Y	Y	Y	Y	Y	
		10 (1010): Ready for jogging "JOG"				Y	Y	Y	N	N	
		11 (1011): Select frequency setting 2/ frequency setting 1 "Hz2/ Hz1"				Y	Y	Y	N	Y	
		12 (1012): Select Motor 2 "M2"				Y	Y	Y	Y	Y	
		13: DC braking command "DCBRK"				Y	Y	Y	N	N	
		14 (1014): Select torque limit 2/ torque limit 1 "TL2/ TL1"				Y	Y	Y	Y	Y	
		15: Switch to commercial power (50 Hz) "SW50"				Y	Y	N	N	N	
		16: Switch to commercial power (60 Hz) "SW60"				Y	Y	N	N	N	
		17 (1017): UP command "UP"				Y	Y	Y	N	Y	
		18 (1018): DOWN command "DOWN"				Y	Y	Y	N	Y	
		19 (1019): Allow function code editing (Data change enabled) "WE-KP"				Y	Y	Y	Y	Y	
		20 (1020): Cancel PID control "Hz/PID"				Y	Y	Y	N	Y	
		21 (1021): Switch normal/ inverse operation "IVS"				Y	Y	Y	N	Y	
		22 (1022): Interlock "IL"				Y	Y	Y	Y	Y	
		23 (1023): Cancel torque control *5 "Hz/TRQ"				N	N	N	Y	N	
		24 (1024): Select link operation (RS-485, BUS option) "LE"				Y	Y	Y	Y	Y	
		25 (1025): Universal DI "U-DI"				Y	Y	Y	Y	Y	
		26 (1026): Select auto search for idling motor speed at starting "STM"				Y	Y	N	N	Y	
		30 (1030): Force to stop (30 = Active OFF/1030 = Active ON) "STOP"				Y	Y	Y	Y	Y	
		32 (1032): Pre-excite *5 "EXITE"				N	N	Y	Y	N	

*5: Available at ROM version 0300 or later.









5.2 Function Codes Table

Code	Name	Data setting range	Change when running	Data copying	Factory Default	Drive control					Related page
						V/f	PG V/f	w/ PG	Torque control	PM	
		33 (1033): Reset PID integral and differential terms "PID-RST"				Y	Y	Y	N	Y	
		34 (1034): Hold PID integral term "PID-HLD"				Y	Y	Y	N	Y	
		35 (1035): Select local (Keypad) command "LOC"				Y	Y	Y	Y	Y	
		42 (1042): Activate the limit switch at start point *5 "LS"				Y	Y	N	N	N	
		43 (1043): Start / Reset *5 "S/R"				Y	Y	N	N	N	
		44 (1044): Switch to the serial pulse receiving mode *5 "SPRM"				Y	Y	N	N	N	
		45 (1045): Enter the return mode *5 "RTN"				Y	Y	N	N	N	
		46 (1046): Enable overload stop "OLS"				Y	Y	Y	N	Y	
		47 (1047): Servo lock command *5 "LOCK"				N	N	Y	N	N	
		49 (1049): Pulse train sign "SIGN"				Y	Y	Y	N	Y	
		59 (1059): Enable battery-driven operation *11 "BATRY/UPS"				Y	Y	Y	N	N	
		60 (1060): Select torque bias1 *5 "TB1"				N	N	Y	N	N	
		61 (1061): Select torque bias2 *5 "TB2"				N	N	Y	N	N	
		62 (1062): Hold torque bias *5 "H-TB"				N	N	Y	N	N	
		65 (1065): Check brake "BRKE"				Y	Y	Y	N	N	
		70 (1070): Cancel line speed control *5 "Hz/LSC"				Y	Y	Y	N	N	
		71 (1071): Hold line speed control frequency in the memory *5 "LSC-HLD"				Y	Y	Y	N	N	
		72 (1072): Count the run time of commercial power-driven motor 1 *5 "CRUN-M1"				Y	Y	Y	Y	N	
		73 (1073): Count the run time of commercial power-driven motor 2 *5 "CRUN-M2"				Y	Y	Y	Y	N	
		76 (1076): Select droop control "DROOP"				Y	Y	Y	N	N	
		78 (1078): Select speed control parameter 1 *5 "MPRM1"				N	Y	Y	Y	Y	
		79 (1079): Select speed control parameter 2 *5 "MPRM2"				N	Y	Y	Y	Y	
		80 (1080): Cancel customizable logic "CLC"				Y	Y	Y	Y	Y	
		81 (1081): Clear all customizable logic timers "CLTC"				Y	Y	Y	Y	Y	
		82 (1082): Cancel anti-regenerative control "AR-CCL"				Y	Y	Y	N	Y	
		98: Run forward / stop command "FWD"				Y	Y	Y	Y	Y	
		99: Run reverse / stop command "REV"				Y	Y	Y	Y	Y	
		100: No function assigned "NONE"				Y	Y	Y	Y	Y	
		171 (1171): PID control multistage command 1 "PID-SS1"				Y	Y	Y	N	Y	
		172 (1172): PID control multistage command 2 "PID-SS2"				Y	Y	Y	N	Y	
		* Inside the () is the negative logic signal. (OFF at short-circuit)									

*5: Available at ROM version 0300 or later.

*11: Available at ROM version 0500 or later.

■ C code: Control Functions of Frequency (Control function)

Code	Name	Data setting range	Change when running	Data copying	Factory Default	Drive control					Related page
						V/f	PG V/f	w/PG	Torque control	PM	
C01	Jump frequency 1 2 3 (Skip width)	0.0 to 500.0Hz	Y	Y	0.0	Y	Y	Y	N	Y	5-139
C02			Y	Y	0.0	Y	Y	Y	N	Y	
C03			Y	Y	0.0	Y	Y	Y	N	Y	
C04		0.0 to 30.0Hz	Y	Y	3.0	Y	Y	Y	N	Y	
C05	Multistep frequency 1 2 3 4 5 6 7 8 9 10 11 12 13 14 15	0.00 to 500.00Hz	Y	Y	0.00	Y	Y	Y	N	Y	5-140
C06			Y	Y	0.00	Y	Y	Y	N	Y	
C07			Y	Y	0.00	Y	Y	Y	N	Y	
C08			Y	Y	0.00	Y	Y	Y	N	Y	
C09			Y	Y	0.00	Y	Y	Y	N	Y	
C10			Y	Y	0.00	Y	Y	Y	N	Y	
C11			Y	Y	0.00	Y	Y	Y	N	Y	
C12			Y	Y	0.00	Y	Y	Y	N	Y	
C13			Y	Y	0.00	Y	Y	Y	N	Y	
C14			Y	Y	0.00	Y	Y	Y	N	Y	
C15			Y	Y	0.00	Y	Y	Y	N	Y	
C16			Y	Y	0.00	Y	Y	Y	N	Y	
C17			Y	Y	0.00	Y	Y	Y	N	Y	
C18			Y	Y	0.00	Y	Y	Y	N	Y	
C19			Y	Y	0.00	Y	Y	Y	N	Y	
C20	Jogging frequency	0.00 to 500.00 Hz	Y	Y	0.00	Y	Y	Y	N	N	5-140
C21	Pattern operation / timed operation (Mode selection) (Stage 1) (Stage 2) (Stage 3) (Stage 4) (Stage 5) (Stage 6) (Stage 7)	0: 1 cycle operation 1: Repetition operation 2: Constant speed operation after 1 cycle operation 3: Timed operation Special setting: Press  key three times. 1st: Set run time 0.0 to 6000 s and press  key. 2nd: Set rotational direction F (forward) or r (reverse) and press  key. 3rd: Set acceleration/deceleration time 1 to 4 and press  key.	N	Y	0	Y	Y	Y	N	Y	5-141
C22			Y	Y	1st: 0.00	Y	Y	Y	N	Y	
C23			Y	Y	2nd: F	Y	Y	Y	N	Y	
C24			Y	Y	3rd: 1	Y	Y	Y	N	Y	
C25			Y	Y		Y	Y	Y	N	Y	
C26			Y	Y		Y	Y	Y	N	Y	
C27			Y	Y		Y	Y	Y	N	Y	
C28			Y	Y		Y	Y	Y	N	Y	
C30	Frequency setting 2	0: Keypad   key operation 1: Analog voltage input (Terminal [12]) (from 0 to ±10 VDC) 2: Analog current input (Terminal [C1] (C1 function)) (4 to 20 mA DC, 0 to 20 mA DC) 3: Analog voltage input (Terminal [12]) + Analog current input (Terminal [C1] (C1 function)) 5: Analog voltage input (Terminal [C1] (V2 function)) (0 to 10 VDC) 7: UP DOWN control 8: Keypad key operation (  key) (With balanceless bumpless) 10: Pattern operation 11: Digital input/output interface card (option) *5 12: Pulse train input	N	Y	2	Y	Y	Y	N	Y	5-143
C31	Analog input adjustment (Terminal [12]) (Offset) (Gain) (Filter) (Gain base point) (Polarity selection)	-5.0 to 5.0%	Y*	Y	0.0	Y	Y	Y	Y	Y	5-144
C32		0.00 to 200.00%	Y*	Y	100.0	Y	Y	Y	Y	Y	
C33		0.00 to 5.00 s	Y	Y	0.05	Y	Y	Y	Y	Y	
C34		0.00 to 100.00%	Y*	Y	100.0	Y	Y	Y	Y	Y	
C35		0: Bipolar 1: Unipolar	N	Y	1	Y	Y	Y	Y	Y	
C36	Analog input adjustment (Terminal [C1] (C1 function)) (Offset) (Gain) (Filter) (Gain base point)	-5.0 to 5.0%	Y*	Y	0.0	Y	Y	Y	Y	Y	
C37		0.00 to 200.00%	Y*	Y	100.0	Y	Y	Y	Y	Y	
C38		0.00 to 5.00 s	Y	Y	0.05	Y	Y	Y	Y	Y	
C39		0.00 to 100.00%	Y*	Y	100.0	Y	Y	Y	Y	Y	
C40	Terminal [C1] (C1 function) range / polarity selection	0: 4 to 20 mA Unipolar 1: 0 to 20 mA Unipolar 10: 4 to 20 mA Bipolar 11: 0 to 20 mA Bipolar	N	Y	0	Y	Y	Y	Y	Y	

*5: Available at ROM version 0300 or later.

5.2 Function Codes Table

Code	Name	Data setting range	Change when running	Data copying	Factory Default	Drive control					Related page
						V/f	PG V/f	w/ PG	Torque control	PM	
C41	Analog input adjustment (Terminal [C1] (V2 function)) (Offset)	-5.0 to 5.0%	Y*	Y	0.0	Y	Y	Y	Y	Y	
C42	(Gain)	0.00 to 200.00%	Y*	Y	100.0	Y	Y	Y	Y	Y	
C43	(Filter)	0.00 to 5.00 s	Y	Y	0.05	Y	Y	Y	Y	Y	
C44	(Gain base point)	0.00 to 100.00%	Y*	Y	100.0	Y	Y	Y	Y	Y	
C45	(Polarity selection)	0: Bipolar 1: Unipolar	N	Y	1	Y	Y	Y	Y	Y	
C50	Bias (for frequency setting 1) (Bias base point)	0.00 to 100.00%	Y*	Y	0.00	Y	Y	Y	N	Y	5-146
C53	Selection of normal/inverse operation (Frequency setting 1)	0: Normal 1: Inverse	Y	Y	0	Y	Y	Y	N	Y	5-146
C55	Analog input adjustment (Terminal 12) (Bias)	-100.00 to 100.00%	Y	Y	0.00	Y	Y	Y	Y	Y	5-144
C56	(Bias base point)	0.00 to 100.00 %	Y	Y	0.00	Y	Y	Y	Y	Y	
C58	(Display unit)	* Same as J105 (However, setting range is, 1 to 80)	Y	Y	2	Y	Y	Y	Y	Y	5-147
C59	(Maximum scale)	-999.00 to 0.00 to 9990.00	N	Y	100	Y	Y	Y	Y	Y	5-147
C60	(Minimum scale)	-999.00 to 0.00 to 9990.00	N	Y	0.00	Y	Y	Y	Y	Y	
C61	Analog input adjustment (Terminal[C1](C1 function)) (Bias)	-100.00 to 100.00 %	Y	Y	0.00	Y	Y	Y	Y	Y	5-144
C62	(Bias base point)	0.00 to 100.00 %	Y	Y	0.00	Y	Y	Y	Y	Y	
C64	(Display unit)	* Same as J105 (However, setting range is, 1 to 80)	Y	Y	2	Y	Y	Y	Y	Y	5-147
C65	(Maximum scale)	-999.00 to 0.00 to 9990.00	N	Y	100	Y	Y	Y	Y	Y	5-147
C66	(Minimum scale)	-999.00 to 0.00 to 9990.00	N	Y	0.00	Y	Y	Y	Y	Y	
C67	Analog input adjustment (Terminal [C1] (V2 function)) (Bias)	-100.00 to 100.00 %	Y	Y	0.00	Y	Y	Y	Y	Y	5-144
C68	(Bias base point)	0.00 to 100.00 %	Y	Y	0.00	Y	Y	Y	Y	Y	
C70	(Display unit)	* Same as J105 (However, setting range is, 1 to 80)	Y	Y	2	Y	Y	Y	Y	Y	5-147
C71	(Maximum scale)	-999.00 to 0.00 to 9990.00	N	Y	100	Y	Y	Y	Y	Y	5-147
C72	(Minimum scale)	-999.00 to 0.00 to 9990.00	N	Y	0.00	Y	Y	Y	Y	Y	
C89	Frequency correction 1 by (Numerator)	-32768 to 32767 (Keypad display is 8000 to 7FFFH) (Interpreted as 1 when the value is set to 0)	Y	Y	0001	Y	Y	Y	N	Y	—
C90	Frequency correction 2 by (Denominator)	-32768 to 32767 (Keypad display is 8000 to 7FFFH) (Interpreted as 1 when the value is set to 0)	Y	Y	0001	Y	Y	Y	N	Y	—

■ P codes: Motor 1 Parameters (Motor 1 parameter)

Code	Name	Data setting range	Change when running	Data copying	Factory Default	Drive control					Related page
						V/f	PG V/f	w/PG	Torque control	PM	
P01	Motor 1 (No. of poles)	2 to 22 poles	N	Y1 Y2	4	Y	Y	Y	Y	Y	5-148
P02	(Rated capacity)	0.01 to 1000 kW (At P99 = 0 or 4, 15) 0.01 to 1000 HP (At P99 = 1)	N	Y1 Y2	*6	Y	Y	Y	Y	Y	5-148
P03	(Rated current)	0.00 to 2000A	N	Y1 Y2	*6	Y	Y	Y	Y	Y	5-148
P04	(Auto-tuning)	0: Disable 1: Stop tuning 2: Rotation tuning 5: Stop tuning(%R1, %X) *5	N	N	0	Y	Y	Y	Y	Y	5-149
P05	(Online tuning)	0: Invalid 1: Valid	Y	Y	0	Y	Y	N	N	N	5-150
P06	(No-load current)	0.00 to 2000A	N	Y1 Y2	*6	Y	Y	Y	Y	N	5-151
P07	(%R1)	0.00 to 50.00%	Y	Y1 Y2	*6	Y	Y	Y	Y	N	
P08	(%X)	0.00 to 50.00%	Y	Y1 Y2	*6	Y	Y	Y	Y	N	
P09	(Slip compensation gain for driving)	0.0 to 200.0%	Y*	Y	100.0	Y	Y	Y	N	N	5-151
P10	(Slip compensation response time)	0.01 to 10.00 s	Y	Y1 Y2	0.5	Y	Y	N	N	N	
P11	(Slip compensation gain for braking)	0.0 to 200.0 %	Y*	Y	100.0	Y	Y	Y	N	N	
P12	(Rated slip frequency)	0.00 to 15.00 Hz	N	Y1 Y2	*6	Y	Y	Y	N	N	5-152
P13	(Iron loss factor 1)	0.00 to 20.00 %	Y	Y1 Y2	*6	Y	Y	Y	Y	N	5-152
P16	(Magnetic saturation factor 1) *5	0.0 to 300.0 %	Y	Y1 Y2	*6	N	N	Y	Y	N	5-152
P17	(Magnetic saturation factor 2) *5	0.0 to 300.0 %	Y	Y1 Y2	*6	N	N	Y	Y	N	
P18	(Magnetic saturation factor 3) *5	0.0 to 300.0 %	Y	Y1 Y2	*6	N	N	Y	Y	N	
P19	(Magnetic saturation factor 4) *5	0.0 to 300.0 %	Y	Y1 Y2	*6	N	N	Y	Y	N	
P20	(Magnetic saturation factor 5) *5	0.0 to 300.0 %	Y	Y1 Y2	*6	N	N	Y	Y	N	
P30	(PMSM drive magnetic pole position detection mode) *5	0: Pull-in by current 1: For IPMSM (Interior permanent magnet synchronous motor) 2: For SPMSM (Surface permanent magnet synchronous motor) 3: Pull-in by current for IPMSM (Interior permanent magnet synchronous motor)	N	Y1 Y2	1	N	N	N	N	Y	5-153
P53	(%X correction factor 1) *5	0 to 300 %	Y	Y1 Y2	100	Y	Y	Y	Y	N	5-153
P55	(Torque current under vector control) *5	0.00 to 2000 A	N	Y1 Y2	*6	N	N	Y	Y	N	5-153
P56	(Induced voltage factor under vector control) *5	50 to 100 %	N	Y1 Y2	*6	N	N	Y	Y	N	
P60	(PMSM armature resistance)*5	0.000 to 50.000 ohm	N	Y1 Y2	*7	N	N	N	N	Y	5-153
P61	(PMSM d-axis inductance)*5	0.00 to 500.00 mH	N	Y1 Y2	*7	N	N	N	N	Y	
P62	(PMSM q-axis inductance)*5	0.00 to 500.00 mH	N	Y1 Y2	*7	N	N	N	N	Y	
P63	(PMSM induced voltage)*5	80 to 240V (200V class); 160 to 500V (400Vclass)	N	Y1 Y2	*7	N	N	N	N	Y	
P64	(PMSM iron loss)*5	0.0 to 20.0 %	Y	Y1 Y2	*7	N	N	N	N	Y	
P65	(PMSM d-axis inductance magnetic saturation correction)*5 *9	0.0 to 100.0 % ; 999	Y	Y1 Y2	*7	N	N	N	N	Y	5-154

■ indicates quick setup target function code.

*5: Available at ROM version 0300 or later.

*6: Factory defaults are depended on motor capacity. Refer to the FRENIC-Ace User's Manual, "5.2.4 Motor constant".

*7: Factory defaults are the parameters for Fuji standard PMSM and depended on motor capacity.

*9: Factory use. Do not access these function codes.

5.2 Function Codes Table

Code	Name	Data setting range	Change when running	Data copying	Factory Default	Drive control					Related page
						V/f	PG V/f	w/PG	Torque control	PM	
P74	(PMSM reference current at starting)*5	10 to 200 % (100%= motor rated current)	Y*	Y1 Y2	*7	N	N	N	N	Y	5-154
P83	(Reserved for PMSM)*5 *9	0.0 to 50.0; 999	Y	Y1 Y2	999	N	N	N	N	-	5-154
P84	(Reserved for PMSM)*5 *9	0.0 to 100.0; 999	N	Y1 Y2	999	N	N	N	N	-	
P85	(PMSM flux limitation value)	50.0 to 150.0; 999	Y	Y1 Y2	999	N	N	N	N	Y	5-154
P86	(Reserved for PMSM)	0 to 100.0%	N	N	0.0	N	N	N	N	-	5-154
P87	(PMSM reference current for polarity discrimination)	0 to 200 %	N	Y1 Y2	60	N	N	N	N	Y	-
P88	(Reserved for PMSM)*5 *9	0 to 100 %; 999	N	Y1 Y2	999	N	N	N	N	-	5-154
P89	(Reserved for PMSM)*5 *9	0; 1 to 100	N	Y1 Y2	0	N	N	N	N	-	
P90	(PMSM overcurrent protection level)*5	0.00(disable); 0.01 to 2000 A	N	Y1 Y2	*7	N	N	N	N	Y	5-154
P99	Motor 1 selection	0: Motor characteristics 0 (Fuji standard IM, 8-series) 1: Motor characteristics 1 (HP rating IMs) 4: Other IMs 20: Other motors(PMSMs) *5 21: Motor characteristics (Fuji PMSM GNB2 series) *5	N	Y1 Y2	U:1 ACEJK:0	Y	Y	Y	Y	Y	5-154

P99 indicates quick setup target function code.

Factory default***A (For Asia), C (for China), E (for Europe), U (For USA), J (for Japan), K (for Korea)

*5: Available at ROM version 0300 or later.

*7: Factory defaults are the parameters for Fuji standard PMSM and depended on motor capacity.

*9: Factory use. Do not access these function codes.

■ H codes: High Performance Functions (High level function)

Code	Name	Data setting range	Change when running	Data copying	Factory Default	Drive control					Related page
						V/f	PG V/f	w/PG	Torque control	PM	
H02	Data initialization (Method)	0: Standard 1: User	N	Y	0	Y	Y	Y	Y	Y	5-155
H03	(Target)	0: Manual setting value 1: Initial value (factory default value) 2: Initialize motor 1 parameters 3: Initialize motor 2 parameters 11: Initialize the parameters(excluding parameters related to communication) 12: Initialize the parameters related to customizable logic	N	N	0	Y	Y	Y	Y	Y	
H04	Auto-reset (Times)	0: Disable, 1 to 20: Number of retries	Y	Y	0	Y	Y	Y	Y	Y	5-157
H05	(Interval)	0.5 to 20.0 s	Y	Y	5.0	Y	Y	Y	Y	Y	
H06	Cooling fan ON/OFF control	0: Disable (Always Fan ON) 1: Enable (ON/OFF control effective)	Y	Y	0	Y	Y	Y	Y	Y	5-158
H07	Curve acceleration/ deceleration	0: Disable (Linear acceleration/deceleration) 1: S-curve acceleration/deceleration (Weak) 2: S-curve acceleration/deceleration (Arbitrary: According to H57 to H60) 3: Curve acceleration/deceleration	Y	Y	0	Y	Y	Y	N	Y	5-158
H08	Rotational direction limitation	0: Disable 1: Enable (Reverse rotation inhibited) 2: Enable (Forward rotation inhibited)	N	Y	0	Y	Y	Y	N	Y	5-158
H09	Starting mode (Auto search)	0: Disable 1: Enable (Only at restart after momentary power failure) 2: Enable (At normal start and at restart after momentary power failure)	N	Y	0	Y	Y	N	N	N	5-159
H11	Deceleration mode	0: Normal deceleration 1: Coast to a stop	Y	Y	0	Y	Y	Y	N	Y	5-161
H12	Instantaneous overcurrent limiting (Mode selection)	0: Disable 1: Enable	Y	Y	1	Y	Y	N	N	N	5-161
H13	Restart mode after momentary power failure (Restart timer)	0.1 to 20.0 s	Y	Y1 Y2	*2	Y	Y	Y	N	N	5-161
H14	(Frequency fall rate)	0.00: Selected deceleration time, 0.01 to 100.00Hz/s, 999 (According to current limiter)	Y	Y	999	Y	Y	N	N	N	
H15	(Continuous running level)	200 to 300V: (200 V class) 400 to 600V: (400V class)	Y	Y2	235 470	Y	Y	Y	N	Y	
H16	(Allowable momentary power failure time)	0.0 to 30.0s, 999 (Depend on inverter judgment)	Y	Y	999	Y	Y	Y	N	Y	
H18	Torque control *5 (Mode selection)	0: Disable (Speed control) 2: Function (Torque current command) 3: Function (Torque command)	N	Y	0	N	N	Y	Y	N	5-162
H26	Thermistor (for motor) (Mode selection)	0: Disable 1: PTC: $\frac{1}{T}$ trip and stop the inverter 2: PTC: Output motor overheat detected "THM" and continue to run	Y	Y	0	Y	Y	Y	Y	Y	5-164
H27	(Level)	0.00 to 5.00 V	Y	Y	1.60	Y	Y	Y	Y	Y	
H28	Droop control	-60.0 to 0.0Hz	Y	Y	0.0	Y	Y	Y	N	N	5-166
H30	Communication link function (Mode selection)	Frequency command Run command 0: F01/C30 F02 1: RS-485 (Port 1) F02 2: F01/C30 RS-485 (Port 1) 3: RS-485 (Port 1) RS-485 (Port 1) 4: RS-485 (Port 2) F02 5: RS-485 (Port 2) RS-485 (Port 1) 6: F01/C30 RS-485 (Port 2) 7: RS-485 (Port 1) RS-485 (Port 2) 8: RS-485 (Port 2) RS-485 (Port 2)	Y	Y	0	Y	Y	Y	Y	Y	5-167
H42	Capacitance of DC link bus capacitor	For adjustment at replacement (0000 to FFFF (in hexadecimal))	Y	N	-	Y	Y	Y	Y	Y	5-169
H43	Cumulative run time of cooling fan	For adjustment at replacement Displays the cumulative run time of cooling fan in units of ten hours.	Y	N	-	Y	Y	Y	Y	Y	
H44	Startup count for motor 1	For adjustment at replacement (0000 to FFFF in hexadecimal)	Y	N	-	Y	Y	Y	Y	Y	5-173
H45	Mock alarm	0: Disable 1: Occurrence of mock Alarm	Y	N	0	Y	Y	Y	Y	Y	5-173
H46	Starting mode (Auto search delay time 2)	0.1 to 20.0 s	Y	Y1 Y2	*6	Y	Y	N	N	Y	5-173

*2: Factory defaults are depended on motor capacity. Refer to "5.2.3 Factory default value per applicable electric motor capacitance".

*5: Available at ROM version 0300 or later.

*6: Factory defaults are depended on motor capacity. Refer to the FRENIC-Ace User's Manual, "5.2.4 Motor constant".

5.2 Function Codes Table

Code	Name	Data setting range	Change when running	Data copying	Factory Default	Drive control					Related page
						V/f	PG V/f	w/PG	Torque control	PM	
H47	Initial capacitance of DC link bus capacitor	For adjustment at replacement (0000 to FFFF in hexadecimal)	Y	N	-	Y	Y	Y	Y	Y	5-173
H48	Cumulative run time of capacitors on printed circuit boards	For adjustment at replacement Change in cumulative motor run time (Reset is enabled) (in units of ten hours)	Y	N	-	Y	Y	Y	Y	Y	5-169 5-173
H49	Starting mode (Auto search delay time 1)	0.0 to 10.0 s	Y	Y	0.0	Y	Y	Y	N	Y	5-174
H50	Non-linear V/f 1 (Frequency)	0.0 (Cancel), 0.1 to 500.0 Hz	N	Y	0.0	Y	Y	N	N	N	5-174
H51	(Voltage)	0 to 240 V:AVR operation (200 V class) 0 to 500V:AVR operation (400V class)	N	Y2	0	Y	Y	N	N	N	
H52	Non-linear V/f 2 (Frequency)	0.0 (Cancel), 0.1 to 500.0 Hz	N	Y	0.0	Y	Y	N	N	N	5-174
H53	(Voltage)	0 to 240V:AVR operation (200V class) 0 to 500V:AVR operation (400V class)	N	Y2	0	Y	Y	N	N	N	
H54	Acceleration time (Jogging)	0.00 to 6000 s	Y	Y	6.00 or 20.0 *10	Y	Y	Y	N	Y	5-174
H55	Deceleration time (Jogging)	0.00 to 6000 s	Y	Y		Y	Y	Y	N	Y	
H56	Deceleration time for forced stop	0.00 to 6000 s	Y	Y		Y	Y	Y	N	Y	
H57	1st S-curve acceleration range (At starting)	0 to 100%	Y	Y	10	Y	Y	Y	N	Y	
H58	2nd S-curve acceleration range (At arrival)	0 to 100%	Y	Y	10	Y	Y	Y	N	Y	
H59	1st S-curve deceleration range (At starting)	0 to 100%	Y	Y	10	Y	Y	Y	N	Y	
H60	2nd S-curve deceleration range (At arrival)	0 to 100%	Y	Y	10	Y	Y	Y	N	Y	
H61	UP/DOWN control (Initial frequency setting)	0: Initial value is 0.00 Hz 1: Last UP/DOWN command value on releasing the run command.	N	Y	1	Y	Y	Y	N	Y	5-174
H63	Low limiter (Mode selection)	0: Limit by F16 (Frequency limiter: Low) and continue to run 1: If the output frequency lowers below the one limited by F16 (Frequency limiter: Low), decelerate to stop the motor.	Y	Y	0	Y	Y	Y	N	Y	5-174
H64	(Lower limiting frequency)	0.0: Depends on F16 (Frequency limiter, Low) 0.1 to 60.0 Hz	Y	Y	1.6	Y	Y	N	N	Y	5-174
H65	Non-linear V/f 3 (Frequency)	0.0 (Cancel), 0.1 to 500.0 Hz	N	Y	0.0	Y	Y	N	N	N	5-174
H66	(Voltage)	0 to 240V: AVR operation (200V class) 0 to 500V: AVR operation (400V class)	N	Y2	0	Y	Y	N	N	N	
H68	Slip compensation 1 (Operating conditions selection)	0: Enable during acceleration/deceleration, enable at base frequency or higher 1: Disable during acceleration/deceleration, enable at base frequency or higher 2: Enable during acceleration/deceleration, disable at base frequency or higher 3: Disable during acceleration/deceleration, disable at base frequency or higher	N	Y	0	Y	Y	N	N	N	5-174
H69	Anti-regenerative control (Mode selection)	0: Disable 2: Torque limit control with force-to-stop (Cancel limit control after three times of deceleration time has passed) 3: DC link bus voltage control with force-to-stop (Cancel voltage control after three times of deceleration time has passed) 4: Torque limit control without force-to-stop 5: DC link bus voltage control without force-to-stop	Y	Y	0	Y	Y	Y	N	Y	5-175
H70	Overload prevention control	0.00: Follow the deceleration time selected 0.01 to 100.00 Hz/s, 999 (Cancel)	Y	Y	999	Y	Y	Y	N	Y	5-176
H71	Deceleration characteristics	0: Disable 1: Enable	Y	Y	0	Y	Y	Y	N	N	5-176
H72	Main power shutdown detection (Mode selection)	0: Disable 1: Enable (Available FRN0088E2■-2□/FRN0059E2■-4□ or above)	Y	Y	1	Y	Y	Y	Y	Y	5-176
H74	Torque limiter *5 (Control target)	0: Torque limit 1: Torque current limit	N	Y	1	N	N	Y	Y	Y	5-177
H76	Torque limiter (Braking) (Frequency rising limiter for braking)	0.0 to 500.0Hz	Y	Y	5.0	Y	Y	N	N	N	5-177
H77	Service life of DC link bus capacitor	0 to 8760 (in units of ten hours)	Y	N	6132 (ND spec)	Y	Y	Y	Y	Y	5-177

*5: Available at ROM version 0300 or later.

*10:6.00s for inverters of nominal applied motor 22kW or below; 20.0s for those of 30kW or above.

5.2 Function Codes Table

Code	Name	Data setting range	Change when running	Data copying	Factory Default	Drive control					Related page
						V/f	PG V/f	w/PG	Torque control	PM	
H78	Maintenance interval (M1)	0 (Disable): 1 to 9999 (in units of ten hours)	Y	N	6132 (ND spec)	Y	Y	Y	Y	Y	5-177
H79	Preset startup count for maintenance (M1)	0000 (Disable): 0001 to FFFF (in hexadecimal)	Y	N	0	Y	Y	Y	Y	Y	5-178
H80	Output current fluctuation damping gain for motor 1	0.00 to 1.00	Y	Y	0.20	Y	Y	N	N	N	5-178
H81	Light alarm selection 1	0000 to FFFF (in hexadecimal)	Y	Y	0	Y	Y	Y	Y	Y	5-179
H82	Light alarm selection 2	0000 to FFFF (in hexadecimal)	Y	Y	0	Y	Y	Y	Y	Y	
H84	Pre-excitation *5 (Level)	100 to 400 % (Motor rated magnetizing current for 100%)	Y	Y	100	N	N	Y	Y	N	5-181
H85	(Timer)	0.00; 0.01 to 30.00 s 0.00; Invalid 0.01 to 30.00 s	Y	Y	0.00	N	N	Y	Y	N	
H86	Reserved *9	0 to 2	Y	Y	0	-	-	-	-	-	5-183
H89	Reserved *9	0 to 1	Y	Y	1	-	-	-	-	-	5-183
H90	Reserved *9	0 to 1	Y	Y	0	-	-	-	-	-	5-183
H91	PID feedback wire break detection	0.0 (Alarm disable): 0.1 to 60.0 s	Y	Y	0.0	Y	Y	Y	N	Y	5-183
H92	Continuous running at the momentary power failure (P)	0.000 to 10.000 times; 999 999:Manufacturer adjustment value	Y	Y1 Y2	999	Y	Y	Y	N	Y	5-183
H93	(I)	0.010 to 10.000 s; 999 999:Manufacturer adjustment value	Y	Y1 Y2	999	Y	Y	Y	N	Y	
H94	Cumulative motor run time 1	0 to 9999 Change in cumulative motor run time (Reset is enabled) (in units of 10 hours)	N	N	-	Y	Y	Y	Y	Y	5-177 5-183
H95	DC braking (Braking response mode)	0: Slow response 1: Quick response	Y	Y	1	Y	Y	N	N	N	5-74 5-183
H96	STOP key priority/ Start check function	0: STOP key priority disable/ Start check function disable 1: STOP key priority enable/ Start check function disable 2: STOP key priority disable/ Start check function enable 3: STOP key priority enable/ Start check function enable	Y	Y	U:3 ACEJK:0	Y	Y	Y	Y	Y	5-184
H97	Clear alarm data	0: Disable 1: Alarm data clear (Automatically return to 0 after clearing data)	Y	N	0	Y	Y	Y	Y	Y	5-184
H98	Protection/Maintenance function (Mode selection)	0 to 127 (Data is displayed in decimal) Bit 0: Lower the carrier frequency automatically (0: Disable; 1: Enable) Bit 1: Input phase loss protection (0: Disable; 1: Enable) Bit 2: Output phase loss protection (0: Disable; 1: Enable) Bit 3: Main circuit capacitor life judgment selection (0: Factory default referenced; 1 User measurement value standard) Bit 4: Judge the life of main circuit capacitor (0: Disable; 1: Enable) Bit 5: Detect DC fan lock (0: Enable; 1: Disable) Bit 6: Braking transistor error detection (0: Disable; 1: Enable)	Y	Y	*11	Y	Y	Y	Y	Y	5-185
H99	Password 2 setting/check	0000 to FFFF (Hexadecimal)	Y	N	0	Y	Y	Y	Y	Y	5-187
H101	Destination	0: Not selected 1: Japan 2: Asia 3: China 4: Europe 5: Americas 7: Korea	N	Y	G(AEU):0 J:1 C:3 K:7	Y	Y	Y	Y	Y	5-190
H111	UPS operation level	120 to 220 VDC: (200 V class) 240 to 440 VDC: (400 V class)	Y	Y2	220 440	Y	Y	Y	N	N	5-190
H114	Anti-regenerative control (Level)	0.0 to 50.0%, 999: disabled	Y	Y	999	Y	Y	Y	N	Y	5-190
H147	Speed control (Jogging) FF (Gain) *5	0.00 to 99.99 s	Y*	Y	0.00	N	N	Y	N	N	5-190 5-230

Factory default...A (For Asia), C (for China), E (for Europe), U (For USA), J (for Japan), K (for Korea)

*5: Available at ROM version 0300 or later.

*9: Factory use. Do not access these function codes.

*11:FRN0115E2■-2□ or below: 83, FRN0072E2■-4□ or below: 83, FRN0012E2■-7□ or below: 83, FRN0085E2■-4□ or above: 19.

5.2 Function Codes Table

Code	Name	Data setting range	Change when running	Data copying	Factory Default	Drive control					Related page
						V/f	PG V/f	w/PG	Torque control	PM	
H154	Torque bias (Mode selection) *5	0: Invalid 1: Digital torque bias 2: Analog torque bias	N	Y	0	N	N	Y	N	N	5-190
H155	(Level 1)	-300 to +300 %	N	Y	0	N	N	Y	N	N	
H156	(Level 2)	-300 to +300 %	N	Y	0	N	N	Y	N	N	
H157	(Level 3)	-300 to +300 %	N	Y	0	N	N	Y	N	N	
H158	(Mechanical loss compensation)	0 to 300 %	N	Y	0	N	N	Y	N	N	
H159	(Startup timer)	0.00 to 1.00 s	N	Y	0.00	N	N	Y	N	N	
H161	(Shutdown timer)	0.00 to 1.00 s	N	Y	0.00	N	N	Y	N	N	
H162	(Limiter)	0 to 300 %	N	Y	200	N	N	Y	N	N	
H173	Magnetic flux level at light load *5	10 to 100 %	Y	Y	100	N	N	Y	Y	N	5-192
H180	Brake control signal (Check-timer for brake operation)	0.00 to 10.00 s	Y	Y	0.00	Y	Y	Y	N	N	5-192
H193	User initial value (Save)	0: Disable, 1: Save	Y	N	0	Y	Y	Y	Y	Y	5-156
H194	(Protection)	0: Save enable, 1: Protected (Save disable)	Y	Y	0	Y	Y	Y	Y	Y	
H195	DC braking (Braking timer at the startup)	0.00 (Disable): 0.01 to 30.00 s	Y	Y	0.00	Y	Y	N	N	N	5-74 5-192
H196	Reserved *5 *9	0.001 to 9.999, 999	Y	Y	999	Y	Y	N	N	N	—
H197	User password 1 (Selection of protective operation)	0: All function codes are disclosed, but the change is not allowed. 1: Only the function code for quick setup can be disclosed/changed. 2: Only the function code for customize logic setting is not disclosed/not changed.	Y	Y	0	Y	Y	Y	Y	Y	5-187
H198	(Setting/check)	0000 to FFFF (Hexadecimal)	Y	N	0	Y	Y	Y	Y	Y	
H199	User password protection valid	0: Disable 1: Protected	Y	N	0	Y	Y	Y	Y	Y	

*5: Available at ROM version 0300 or later.

*9: Factory use. Do not access these function codes.

■ A codes: Motor 2 Parameters (Motor 2 parameters)

Code	Name	Data setting range	Change when running	Data copying	Factory Default	Drive control					Related page
						V/f	PG V/f	w/PG	Torque control	PM	
A01	Maximum output frequency 2	25.0 to 500.0Hz	N	Y	200V class AJKU:60.0 400V class ACE:50.0 JKU:60.0	Y	Y	Y	Y	N	-
A02	Base frequency 2	25.0 to 500.0Hz	N	Y	200V class J:50.0 AUK:60.0 400V class ACEJ:50.0 UK:60.0	Y	Y	Y	Y	N	
A03	Rated voltage at base frequency 2	0: AVR disable (output voltage proportional to power voltage) 80 to 240V: AVR operation (200V class) 160 to 500V: AVR operation (400V class)	N	Y2	200V class J:200 AK:220 U:230	Y	Y	Y	Y	N	
A04	Maximum output voltage 2	80 to 240V: AVR operation (200V class) 160 to 500V: AVR operation (400V class)	N	Y2	400V class EJ:400 A:415 CK:380 U:460	Y	Y	N	Y	N	
A05	Torque boost 2	0.0 to 20.0% (% value against base frequency voltage 2)	Y	Y	*2	Y	Y	N	N	N	
A06	Electronic thermal overload protection for motor 2 (Select motor characteristics)	1: Enable (For a general-purpose motor with self-cooling fan) 2: Enable (For an inverter-driven motor with separately powered cooling fan)	Y	Y	1	Y	Y	Y	Y	N	
A07	(Overload detection level)	0.00 (disable), current value of 1 to 135% of inverter rated current	Y	Y1 Y2	*3	Y	Y	Y	Y	N	
A08	(Thermal time constant)	0.5 to 75.0 min	Y	Y	*4	Y	Y	Y	Y	N	
A09	DC braking 2 (Braking starting frequency)	0.0 to 60.0Hz	Y	Y	0.0	Y	Y	Y	N	N	
A10	(Braking level)	0 to 100% (HHD mode), 0 to 80% (HD/HND mode) 0 to 60% (ND mode)	Y	Y	0	Y	Y	Y	N	N	
A11	(Braking time)	0.00 (Disable): 0.01 to 30.00 s	Y	Y	0.00	Y	Y	Y	N	N	
A12	Starting frequency 2	0.0 to 60.0Hz	Y	Y	0.5	Y	Y	Y	N	N	
A13	Load selection / Auto torque boost/ Auto energy-saving operation 2	0: Variable torque load 1: Constant torque load 2: Auto torque boost 3: Auto energy-saving operation (variable torque load) 4: Auto energy-saving operation (constant torque load) 5: Auto energy-saving operation with auto torque boost	N	Y	1	Y	Y	Y	N	N	
A14	Drive control selection 2	0: V/f control without slip compensation 1: Vector control without speed sensor (Dynamic torque vector control) 2: V/f control with slip compensation 3: V/f control with speed sensor 4: V/f control with speed sensor and auto torque boost 6: Vector control for induction motor with speed sensor	N	Y	0	Y	Y	Y	Y	N	
A15	Motor 2 (No. of poles)	2 to 22 poles	N	Y1 Y2	4	Y	Y	Y	Y	N	
A16	(Rated capacity)	0.01 to 1000 kW (At P39 = 0, 4) 0.01 to 1000 HP (At P39 = 1)	N	Y1 Y2	*6	Y	Y	Y	Y	N	
A17	(Rated current)	0.00 to 2000A	N	Y1 Y2	*6	Y	Y	Y	Y	N	
A18	(Auto-tuning)	0: Disable 1: Stop tuning 2: Rotation tuning 5: Stop tuning (%R1, %X)	N	N	0	Y	Y	Y	Y	N	
A19	(Online tuning)	0: Invalid 1:Valid	Y	Y	0	Y	N	N	N	N	
A20	(No-load current)	0.00 to 2000A	N	Y1 Y2	*6	Y	Y	Y	Y	N	
A21	(%R1)	0.00 to 50.00%	Y	Y1 Y2	*6	Y	Y	Y	Y	N	
A22	(%X)	0.00 to 50.00%	Y	Y1 Y2	*6	Y	Y	Y	Y	N	

Factory default***A (For Asia), C (for China), E (for Europe), U (For USA), J (for Japan), K (for Korea)

*2: Factory defaults are depended on motor capacity. Refer to "5.2.3 Factory default value per applicable electric motor capacitance".

*3: The motor rated current is automatically set. Refer to the FRENIC-Ace User's Manual, "5.2.4 Motor constant" (function code P03).

*4: Standard applicable electric motor is 5.0 min for 22 kW or lower and 10.0 min for 30 kW or higher.

*6: Factory defaults are depended on motor capacity. Refer to the FRENIC-Ace User's Manual, "5.2.4 Motor constant".

5.2 Function Codes Table

Code	Name	Data setting range	Change when running	Data copying	Factory Default	Drive control					Related page
						V/f	PG V/f	w/PG	Torque control	PM	
A23	Motor 2 (Slip compensation gain for driving)	0.0 to 200.0%	Y*	Y	100.0	Y	Y	Y	N	N	5-228
A24	(Slip compensation response time)	0.01 to 10.00 s	Y	Y1 Y2	0.50	Y	Y	N	N	N	
A25	(Slip compensation gain for braking)	0.0 to 200.0%	Y*	Y	100.0	Y	Y	Y	N	N	
A26	(Rated slip frequency)	0.00 to 15.00Hz	N	Y1 Y2	*6	Y	Y	Y	N	N	
A27	(Iron loss factor 1)	0.00 to 20.00%	Y	Y1 Y2	*6	Y	Y	Y	Y	N	
A30	(Magnetic saturation factor 1) *5	0.0 to 300.0 %	Y	Y1 Y2	*6	N	N	Y	Y	N	
A31	(Magnetic saturation factor 2) *5	0.0 to 300.0 %	Y	Y1 Y2	*6	N	N	Y	Y	N	
A32	(Magnetic saturation factor 3) *5	0.0 to 300.0 %	Y	Y1 Y2	*6	N	N	Y	Y	N	
A33	(Magnetic saturation factor 4) *5	0.0 to 300.0 %	Y	Y1 Y2	*6	N	N	Y	Y	N	
A34	(Magnetic saturation factor 5) *5	0.0 to 300.0 %	Y	Y1 Y2	*6	N	N	Y	Y	N	
A39	Motor 2 selection	0: Motor characteristics 0 (Fuji standard IM, 8-series) 1: Motor characteristics 1 (HP rating IMs) 4: Other IMs	N	Y1 Y2	U:1 ACEJK:0	Y	Y	Y	Y	N	
A40	Slip compensation 2 (Operating conditions selection)	0: Enable during acceleration/deceleration, enable at base frequency or higher 1: Disable during acceleration/deceleration, enable at base frequency or higher 2: Enable during acceleration/deceleration, disable at base frequency or higher 3: Disable during acceleration/deceleration, disable at base frequency or higher	N	Y	0	Y	Y	N	N	N	
A41	Output current fluctuation damping gain for motor 2	0.00 to 1.00	Y	Y	0.20	Y	Y	N	N	N	
A43	Speed control 2 *5 (Speed command filter)	0.000 to 5.000 s	Y	Y	0.020	N	Y	Y	N	Y	
A44	(Speed detection filter)	0.000 to 0.100 s	Y*	Y	0.005	N	Y	Y	N	Y	
A45	P (Gain)	0.1 to 200.0 times	Y*	Y	10.0	N	Y	Y	N	Y	
A46	I (Integral time)	0.001 to 9.999 s; 999 (Cancel integral term)	Y	Y	0.100	N	Y	Y	N	Y	
A47	FF (Gain)	0.00 to 99.99 s	Y	Y	0.00	N	N	Y	N	Y	
A49	(Notch filter resonance frequency)	1 to 200 Hz	Y	Y	200	N	N	Y	N	N	
A50	(Notch filter attenuation level)	0 to 20 dB	Y	Y	0	N	N	Y	N	N	
A51	Cumulative motor run time 2	0 to 9999 Change in cumulative motor run time (Reset is enabled) (in units of 10 hours)	N	N	-	Y	Y	Y	Y	N	-
A52	Startup counter for motor 2	For adjustment at replacement (0000 to FFFF in hexadecimal)	Y	N	-	Y	Y	Y	Y	N	
A53	Motor 2 (%X correction factor 1)	0 to 300%	Y	Y1 Y2	100	Y	Y	Y	Y	N	
A55	(Torque current under vector control) *5	0.00 to 2000 A	N	Y1 Y2	*6	N	N	Y	Y	N	
A56	(Induced voltage factor under vector control) *5	50 to 100 %	N	Y1 Y2	*6	N	N	Y	Y	N	
A98	Motor 2 (Function selection)	0 to 255 (Data is displayed in decimal, Meaning of each bit 0: Disable; 1 Enable) bit0: Current limiter (F43, F44) bit1: Rotational direction control (H08) bit2: Non-linear V/f (H50 to H53, H65, H66) bit3: PID control (J01 to J62, H91) bit4: Brake signal bit5: Braking timer at the Startup (H195) Bit6 to 7: Reserved *9	N	Y	0	Y	Y	Y	Y	Y	5-195

Factory default---A (For Asia), C (for China), E (for Europe), U (For USA), J (for Japan), K (for Korea)

*5: Available at ROM version 0300 or later.

*6: Factory defaults are depended on motor capacity. Refer to the FRENIC-Ace User's Manual, "5.2.4 Motor constant".

*9: Factory use. Do not change these function codes.

■ **b codes: Motor control parameter 3**

Code	Name	Data setting range	Change when running	Data copying	Factory Default	Drive control					Related page
						V/f	PG V/f	w/PG	Torque control	PM	
b43	Speed control 3 *5 (Speed command filter)	0.000 to 5.000 s	Y	Y	0.020	N	Y	Y	N	Y	5-228
b44	(Speed detection filter)	0.000 to 0.100 s	Y*	Y	0.005	N	Y	Y	N	Y	
b45	P (Gain)	0.1 to 200.0	Y*	Y	10.0	N	Y	Y	N	Y	
b46	I (Integral time)	0.001 to 9.999 s; 999 (Cancel integral term)	Y*	Y	0.100	N	Y	Y	N	Y	
b47	FF (Gain)	0.00 to 99.99	Y*	Y	0.00	N	N	Y	N	Y	
b49	(Notch filter resonance frequency)	1 to 200Hz	Y	Y	200	N	N	Y	N	N	
b50	(Notch filter attenuation level)	0 to 20dB	Y	Y	0	N	N	Y	N	N	

*5: Available at ROM version 0300 or later.

■ **r codes: Motor control parameter 4**

Code	Name	Data setting range	Change when running	Data copying	Factory Default	Drive control					Related page
						V/f	PG V/f	w/PG	Torque control	PM	
r43	Speed control 4 *5 (Speed command filter)	0.000 to 5.000 s	Y	Y	0.020	N	Y	Y	N	Y	5-228
r44	(Speed detection filter)	0.000 to 0.100 s	Y*	Y	0.005	N	Y	Y	N	Y	
r45	P (Gain)	0.1 to 200.0 times	Y*	Y	10.0	N	Y	Y	N	Y	
r46	I (Integral time)	0.001 to 9.999 s; 999 (Cancel integral term)	Y*	Y	0.100	N	Y	Y	N	Y	
r47	FF (Gain)	0.00 to 99.99	Y*	Y	0.00	N	N	Y	N	Y	
r49	(Notch filter resonance frequency)	1 to 200 Hz	Y	Y	200	N	N	Y	N	N	
r50	(Notch filter attenuation level)	0 to 20 dB	Y	Y	0	N	N	Y	N	N	

*5: Available at ROM version 0300 or later.

■ J codes: Application Functions 1 (Application function 1)

Code	Name	Data setting range	Change when running	Data copying	Factory Default	Drive control					Related page
						V/f	PG V/f	w/PG	Torque control	PM	
J01	PID control (Mode selection)	0: Disable 1: Process (normal operation) 2: Process (inverse operation) 3: Speed control (Dancer)	N	Y	0	Y	Y	Y	N	Y	5-197
J02	(Remote command)	0: Keypad key operation (⏏/⏏key) 1: PID process command 1 (Analog input: Terminals 12, C1 and V2) 3: UP/DOWN 4: Communication	N	Y	0	Y	Y	Y	N	Y	5-198
J03	P (Gain)	0.000 to 30.000 times	Y	Y	0.100	Y	Y	Y	N	Y	5-204
J04	I (Integral time)	0.0 to 3600.0 s	Y	Y	0.0	Y	Y	Y	N	Y	
J05	D (Differential time)	0.00 to 600.00 s	Y	Y	0.00	Y	Y	Y	N	Y	
J06	(Feedback filter)	0.0 to 900.0 s *1	Y	Y	0.5	Y	Y	Y	N	Y	
J10	(Anti-reset windup)	0 to 200%	Y	Y	200	Y	Y	Y	N	Y	5-207
J11	(Select Warnig output)	0: Warning caused by process command value 1: Warning caused by process command value with hold 2: Warning caused by process command value with latch 3: Warning caused by process command value with hold and latch 4: Warning caused by PID error value 5: Warning caused by PID error value with hold 6: Warning caused by PID error value with latch 7: Warning caused by PID error value with hold and latch	Y	Y	0	Y	Y	Y	N	Y	5-208
J12	(Upper limit of warning (AH))	-100% to 100%	Y	Y	100	Y	Y	Y	N	Y	
J13	(Lower limit of warning (AL))	-100% to 100%	Y	Y	0	Y	Y	Y	N	Y	
J15	(Sleep frequency)	0.0 (Disable): 1.0 to 500.0 Hz	Y	Y	0.0	Y	Y	Y	N	Y	5-210
J16	(Sleep timer)	0 to 60 s	Y	Y	30	Y	Y	Y	N	Y	
J17	(Wakeup frequency)	0.0 to 500.0Hz	Y	Y	0.0	Y	Y	Y	N	Y	
J18	(Upper limit of PID process output)	-150% to 150% ; 999 (Depends on setting of F15)	Y	Y	999	Y	Y	Y	N	Y	5-211
J19	(Lower limit of PID process output)	-150% to 150% ; 999 (Depends on setting of F16)	Y	Y	999	Y	Y	Y	N	Y	
J23	(Wakeup level of PID error)	0.0 to 100.0%	Y	Y	0.0	Y	Y	Y	N	Y	5-210
J24	(Wakeup timer)	0 to 3600 s	Y	Y	0	Y	Y	Y	N	Y	
J57	(Dancer position set point)	-100 to 0 to 100%	Y	Y	0	Y	Y	Y	N	Y	5-211
J58	(Detection width of dancer position error)	0: Disable switching PID constant 1 to 100%: Manually set value	Y	Y	0	Y	Y	Y	N	Y	5-212
J59	P (Gain) 2	0.000 to 30.000 times	Y	Y	0.100	Y	Y	Y	N	Y	
J60	I (Integral time) 2	0.0 to 3600.0 s	Y	Y	0.0	Y	Y	Y	N	Y	
J61	D (Differential time) 2	0.00 to 600.00 s	Y	Y	0.00	Y	Y	Y	N	Y	
J62	(PID control block selection)	0 to 3 bit0: Select polarity compensation for PID output/error 0=Plus (Addition); 1=Minus (Subtraction) bit1: Select compensation factor for PID output 0=Ratio (relative to the main setting) 1=Speed command (relative to maximum frequency)	N	Y	0	Y	Y	Y	N	Y	5-212
J63	Overload stop (Item selection)	0: Torque, 1: Current	Y	Y	0	Y	Y	Y	N	Y	5-213
J64	(Detection level)	20 to 200%	Y	Y	100	Y	Y	Y	N	Y	
J65	(Mode selection)	0: Disable 1: Decelerate to stop 2: Coast to a stop	N	Y	0	Y	Y	Y	N	Y	
J66	(Operation mode)	0: During constant speed running and deceleration 1: During constant speed running 2: Anytime	Y	Y	0	Y	Y	Y	N	Y	
J67	(Timer)	0.00 to 600.00 s	Y	Y	0.00	Y	Y	Y	N	Y	

5.2 Function Codes Table

Code	Name	Data setting range	Change when running	Data copying	Factory Default	Drive control					Related page
						V/f	PG V/f	w/PG	Torque control	PM	
J68	Brake control signal (Brake-release current)	0.00 to 300.00%	Y	Y	100.0	Y	Y	Y	N	N	5-214
J69	(Brake-release frequency/speed)	0.0 to 25.0 Hz	Y	Y	1.0	Y	Y	N	N	N	
J70	(Brake-release timer)	0.00 to 5.00 s	Y	Y	1.00	Y	Y	Y	N	N	
J71	(Brake-applied frequency/speed)	0.0 to 25.0 Hz	Y	Y	1.0	Y	Y	Y	N	N	
J72	(Brake-applied timer)	0.00 to 5.00 s	Y	Y	1.00	Y	Y	Y	N	N	
J73	Positioning control *5 (Start timer)	0.0 to 1000.0 s	Y	Y	0.0	Y	Y	N	N	N	5-217
J74	(Start point; upper digits)	-999(83E7) to 999(03E7) -999(83E7) to -1(8001) 0(0000) to 999(03E7)	Y	Y	0	Y	Y	N	N	N	
J75	(Start point; lower digits)	0(0000) to 9999(270F) ; P = -1(FFFF)	Y	Y	0	Y	Y	N	N	N	
J76	(Preset point; upper digits)	-999(83E7) to 999(03E7) -999(83E7) to -1(8001) 0(0000) to 999(03E7)	Y	Y	0	Y	Y	N	N	N	
J77	(Preset point; lower digits)	0(0000) to 9999(270F) ; P = -1(FFFF)	Y	Y	0	Y	Y	N	N	N	
J78	(Creep speed SW point; upper digits)	0 to 999	Y	Y	0	Y	Y	N	N	N	
J79	(Creep speed SW point; lower digits)	0 to 9999	Y	Y	0	Y	Y	N	N	N	
J80	(Creep speed)	0 to 500 Hz	Y	Y	0.0	Y	Y	N	N	N	
J81	(End point; upper digits)	-999(83E7) to 999(03E7) -999(83E7) to -1(8001) 0(0000) to 999(03E7)	Y	Y	0	Y	Y	N	N	N	
J82	(End point; lower digits)	0(0000) to 9999(270F)	Y	Y	0	Y	Y	N	N	N	
J83	(Completion range)	0 to 9999	Y	Y	0	Y	Y	N	N	N	
J84	(End timer)	0.0 to 1000.0 s	Y	Y	0.0	Y	Y	N	N	N	
J85	(Coasting compensation)	0 to 9999	Y	Y	0	Y	Y	N	N	N	
J86	(End point: serial pulse input format)	0: Direction and pulse 1: Forward and reverse pulse	Y	Y	0	Y	Y	N	N	N	
J87	(Preset positioning requirement)	0: Allow to preset at the forward rotation only 1: Allow to preset at the reverse rotation only 2: Allow to preset at any rotations	N	Y	0	Y	Y	N	N	N	
J88	(Direction of detected position)	0: Not switch the direction of detected position 1: Switch the direction of detected position	N	Y	0	Y	Y	N	N	N	
J95	Brake control signal *5 (Brake-release torque)	0.00 to 300.00 %	Y	Y	100.00	N	N	Y	N	N	5-214
J96	(Brake-apply conditions)	0 to 31 Bit0: Speed detection / Speed command (0: Speed detection ; 1: Speed command) Bit1: Reserved Bit2: Reserved Bit3: Reserved Bit4: Brake-apply condition (0: Regardless of run command status (ON or OFF) ; 1: Only when run command is OFF.)	Y	Y	0	N	N	Y	N	N	
J97	Servo lock *5 (Gain)	0.000 to 9.999 times	Y*	Y	0.010	N	N	Y	N	N	5-226
J98	(Completion timer)	0.000 to 1.000 s	Y	Y	0.100	N	N	Y	N	N	
J99	(Completion range)	0 to 9999	Y	Y	10	N	N	Y	N	N	

*5: Available at ROM version 0300 or later.

5.2 Function Codes Table

Code	Name	Data setting range	Change when running	Data copying	Factory Default	Drive control					Related page
						V/f	PG V/f	w/PG	Torque control	PM	
J105	PID control (Display unit)	0 to 80 0: Inherit (PID Control 1 feedback unit) 1: none 2: % 4: r/min 7: kW [Flow] 20: m ³ /s 21: m ³ /min 22: m ³ /h 23: L/s 24: L/min 25: L/h [Pressure] 40: Pa 41: kPa 42: MPa 43: mbar 44: bar 45: mmHg 46: psi PSI (Pounds per square inch absolute) 47: mWG 48: inWG [Temperature] 60: K 61: degreeC 62: degreeF [Concentration] 80: ppm	N	Y	0	Y	Y	Y	N	Y	5-227
J106	(Maximum scale)	-999.00 to 0.00 to 9990.00	N	Y	100	Y	Y	Y	N	Y	
J107	(Minimum scale)	-999.00 to 0.00 to 9990.00	N	Y	0.00	Y	Y	Y	N	Y	
J136	PID multistep command (Multistep command 1)	-999.00 to 0.00 to 9990.00	Y	Y	0.00	Y	Y	Y	N	Y	5-227
J137	(Multistep command 2)	-999.00 to 0.00 to 9990.00	Y	Y	0.00	Y	Y	Y	N	Y	
J138	(Multistep command 3)	-999.00 to 0.00 to 9990.00	Y	Y	0.00	Y	Y	Y	N	Y	

■ d codes: Application Functions 2 (Application function 2)

Code	Name	Data setting range	Change when running	Data copying	Factory Default	Drive control					Related page
						V/f	PG V/f	w/PG	Torque control	PM	
d01	Speed control 1 *5 (Speed command filter)	0.000 to 5.000 s	Y	Y	0.020	N	Y	Y	N	Y	5-228
d02	(Speed detection filter)	0.000 to 0.100 s	Y*	Y	0.005	N	Y	Y	N	Y	
d03	P (Gain)	0.1 to 200.0 times	Y*	Y	10.0	N	Y	Y	N	Y	
d04	I (Integral time)	0.001 to 9.999 s; 999(Cancel integral term)	Y	Y	0.100	N	Y	Y	N	Y	
d05	FF (Gain)	0.00 to 99.99 s	Y	Y	0.00	N	N	Y	N	Y	
d07	(Notch filter resonance frequency)	1 to 200 Hz	Y	Y	200	N	N	Y	N	N	
d08	(Notch filter attenuation level)	0 to 20dB	Y	Y	0	N	N	Y	N	N	
d09	Speed control (Jogging) *5 (Speed command filter)	0.000 to 5.000 s	Y	Y	0.020	N	Y	Y	N	N	
d10	(Speed detection filter)	0.000 to 0.100 s	Y*	Y	0.005	N	Y	Y	N	N	
d11	P (Gain)	0.1 to 200.0 times	Y*	Y	10.0	N	Y	Y	N	N	
d12	I (Integral time)	0.001 to 9.999 s; 999(Cancel integral term)	Y*	Y	0.100	N	Y	Y	N	N	
d14	Feedback Input *5 (Pulse input format)	0: Frequency and direction 1: Forward and reverse pulse 2: Quadrature A/B signal(B phase lead) 3: Quadrature A/B signal(A phase lead)	N	Y	2	N	Y	Y	Y	N	5-231
d15	(Encoder pulse resolution)	0014 to EA60(Hexadecimal) pulses (20 to 60000 (Decimal) pulses)	N	Y	0400 (1024)	N	Y	Y	Y	N	
d16	(Pulse scaling factor 1)	1 to 9999	N	Y	1	N	Y	Y	Y	N	
d17	(Pulse scaling factor 2)	1 to 9999	N	Y	1	N	Y	Y	Y	N	
d21	Speed agreement / PG error *5 (Hysteresis width)	0.0 to 50.0 %	Y	Y	10.0	N	Y	Y	N	Y	5-233
d22	(Detection timer)	0.00 to 10.00 s	Y	Y	0.50	N	Y	Y	N	Y	
d23	PG error processing *5	0: Continue to run 1 1: Stop with alarm 1 2: Stop with alarm 2 3: Continue to run 2 4: Stop with alarm 3 5: Stop with alarm 4	N	Y	2	N	Y	Y	N	Y	
d24	Zero speed control *5	0: Disable at startup 1: Enable at startup	N	Y	0	N	N	Y	N	N	5-234
d25	ASR switching time *5	0.000 to 1.000 s	Y	Y	0.000	N	Y	Y	Y	Y	5-234
d32	Speed limit / Over speed level 1 *5	0 to 110 %	Y	Y	100	N	N	Y	Y	Y	5-234
d33	Speed limit / Over speed level 2 *5	0 to 110 %	Y	Y	100	N	N	Y	Y	Y	
d35	Over speed detection level *5	0 to 120 %; 999 999: Depend on d32, d33	Y	Y	999	N	Y	Y	Y	Y	5-234
d41	Application specific function selection *5	0: Invalid 1: Line speed control with speed sensor 2: Master-follower operation (Immediate synchronization mode at the start, without Z phase) 3: Master-follower operation (Start after synchronization mode) 4: Master-follower operation (Immediate synchronization mode at the start, with Z phase)	N	Y	0	N	Y	N	N	N	5-234
d51	Reserved *9	-500 to 500	N	Y	*12	Y	Y	Y	Y	Y	5-237
d52	Reserved *9	-500 to 500	N	Y	*12	Y	Y	Y	Y	Y	
d55	Reserved *9	0000 to 00FF (Display in hexadecimal)	N	Y	0	Y	Y	Y	Y	Y	
d59	Command (Pulse train input) *5 (Pulse input format)	0: Frequency and direction 1: Forward and reverse pulse 2: Quadrature A/B signal(B phase lead) 3: Quadrature A/B signal(A phase lead)	N	Y	0	Y	Y	Y	Y	Y	5-244
d60	(Encoder pulse resolution)	0014 to 0E10 (Hexadecimal) pulses (20 to 3600 (Decimal) pulses)	N	Y	0400 (1024)	N	Y	Y	N	N	5-237
d61	(Filter time constant)	0.000 to 5.000 s	Y	Y	0.005	Y	Y	Y	Y	Y	5-237
d62	(Pulse scaling factor 1)	1 to 9999	Y	Y	1	Y	Y	Y	Y	Y	
d63	(Pulse scaling factor 2)	1 to 9999	Y	Y	1	Y	Y	Y	Y	Y	

*5: Available at ROM version 0300 or later.

*9: Factory use. Do not change these function codes.

*12: FRN0012E2-7□ or below; 20, FRN0115E2-2□ or below; 20, FRN0290E2-4□ or below; 20, FRN0361E2-4□ and FRN0415E2-4□:50, FRN0520E2-4□ or above: 100.

5.2 Function Codes Table

Code	Name	Data setting range	Change when running	Data copying	Factory Default	Drive control					Related page
						V/f	PG V/f	w/ PG	Torque control	PM	
d67	PMSM starting mode *5 (Auto search)	0: Disable 1: Enable (At restart after momentary power failure) 2: Enable (At restart after momentary power failure and at normal start)	N	Y	2	N	N	N	N	Y	5-159 5-237
d69	Reserved *9	30.0 to 100.0Hz	Y	Y	30.0	Y	Y	N	N	N	5-237
d70	Speed control limiter *5	0.00 to 100.00 %	Y	Y	100.00	N	Y	N	N	N	5-247
d71	Master follower control *5 (Main speed regulator gain)	0.00 to 1.50 times	Y	Y	1.00	N	Y	Y	N	N	5-238
d72	(APR gain)	0.00 to 200.00 times	Y	Y	15.00	N	Y	Y	N	N	
d73	(APR positive output limiter)	20 to 200 %; 999: Invalid	Y	Y	999	N	Y	Y	N	N	
d74	(APR negative output limiter)	20 to 200 %; 999: Invalid	Y	Y	999	N	Y	Y	N	N	
d75	(Z phase alignment gain)	0.00 to 10.00 times	Y	Y	1.00	N	Y	Y	N	N	
d76	(Offset angle between master and follower)	0 to 359 deg	Y	Y	0	N	Y	Y	N	N	
d77	(Synchronous completion detection angle)	0 to 359 deg	Y	Y	15	N	Y	Y	N	N	
d78	(Excessive error detection level)	0 to 65535 (10 unit pulse)	Y	Y	65535	N	Y	Y	N	N	
d79	Reserved *5 *9	0; 80 to 240 V (200V order) 160 to 500 V (400V order); 999	N	Y2	0	N	N	N	N	Y	5-237
d88	Reserved *5 *9	0.00 to 100.00 %, 999	Y	Y	999	N	N	N	N	Y	5-247
d90	Magnetic flux level during deceleration under vector control *5	100 to 300 %	Y	Y	150	N	N	Y	N	N	
d91	Reserved *9	0.00 to 2.00, 999	Y	Y	999	-	-	-	-	-	5-237
d92	Reserved *5 *9	0.00 to 10.00	Y	Y	0.30	-	-	-	-	-	
d93	Reserved *5 *9	0.00 to 10.00; 999	Y	Y	999	N	N	N	N	Y	
d94	Reserved *5 *9	0.00 to 10.00; 999	Y	Y	999	N	N	N	N	Y	
d95	Reserved *5 *9	0.00 to 10.00; 999	Y	Y	999	N	N	N	N	Y	
d96	Reserved *5 *9	-50.0 to 50.0; 999	Y	Y	999	N	N	N	N	Y	
d97	Reserved *5 *9	-50.0 to 50.0; 999	Y	Y	999	N	N	N	N	Y	
d99	Extension function 1	0 to 127	Y	Y	0						
		Bit 0-2: Reserved *9				-	-	-	-	-	
		Bit 3: JOG operation from communication (0: Disable; 1: Enable)				Y	Y	Y	N	Y	
		Bit 4-8: Reserved *9				-	-	-	-	-	

*5: Available at ROM version 0300 or later.

*9: Factory use. Do not change these function codes.

■ U codes: Application Functions 3 (Customizable logic)

Code	Name	Data setting range	Change when running	Data copying	Factory Default	Drive control					Related page
						V/f	PG V/f	w/PG	Torque control	PM	
U00	Customizable logic (Mode selection)	0: Disable 1: Enable (Customizable logic operation) ECL alarm occurs when the value is changed from 1 to 0 during operation.	Y	Y	0	Y	Y	Y	Y	Y	5-250
U01	Customizable logic: Step 1 (Block selection)	[Digital] 0: No function assigned 10 to 15: Through output + General-purpose timer 20 to 25: Logical AND + General-purpose timer 30 to 35: Logical OR + General-purpose timer 40 to 45: Logical XOR + General-purpose timer 50 to 55: Set priority flip-flop + General-purpose timer 60 to 65: Reset priority flip-flop + General-purpose timer 70, 72, 73: Rising edge detector + General-purpose timer 80, 82, 83: Falling edge detector + General-purpose timer 90, 92, 93: Rising & falling edges detector + General-purpose timer 100 to 105: Hold + General-purpose timer 110: Increment counter 120: Decrement counter 130: Timer with reset input General-purpose timer function (Least significant digit 0 to 5) _0: No timer _1: On-delay timer _2: Off-delay timer _3: Pulse (1 shot) _4: Retriggerable timer _5: Pulse train output [Analog] 2001: Adder 2002: Subtractor 2003: Multiplier 2004: Divider 2005: Limiter 2006: Absolute value of input 2007: Inverting adder 2008: Variable limiter 2009: Linear function 2051 to 2056: Comparator1 to 6 2071, 2072: Window comparator1, 2 2101: High selector 2102: Low selector 2103: Average of inputs 2151: Loading function from S13 2201: Clip and map function 2202: Scale converter 3001: Quadratic function 3002: Square root function [Digital, Analog] 4001: Hold 4002: Inverting adder with enable 4003, 4004: Selector 1, 2 4005: LPF(Low-pass filter) with enable 4006: Rate limiter with enable 5000: Selector 3 5100: Selector 4 6001: Reading function code 6002: Writing function code 6003: Temporary change of function code 6101: PID dancer output gain frequency	N	Y	0	Y	Y	Y	Y	Y	

5.2 Function Codes Table

Code	Name	Data setting range	Change when running	Data copying	Factory Default	Drive control					Related page
						V/f	PG V/f	w/PG	Torque control	PM	
U02	Customizable logic: Step 1 (Input 1)	[Digital] 0 to 105: The same as E20 value. However, 27, 111 to 120 cannot be selected	N	Y	100	Y	Y	Y	Y	Y	
U03	(Input 2)	2001 to 2200 (3001 to 3200): Output of Step 1 to 200 4001 (5001): X1 terminal input signal "X1" 4002 (5002): X2 terminal input signal "X2" 4003 (5003): X3 terminal input signal "X3" 4004 (5004): X4 terminal input signal "X4" 4005 (5005): X5 terminal input signal "X5" 4010 (5010): FWD terminal input signal "FWD" 4011 (5011): REV terminal input signal "REV" *4021(5021): Digital input I1 (OPC-DIO) *5 *4022(5022): Digital input I2 (OPC-DIO) *5 *4023(5023): Digital input I3 (OPC-DIO) *5 *4024(5024): Digital input I4 (OPC-DIO) *5 *4025(5025): Digital input I5 (OPC-DIO) *5 *4026(5026): Digital input I6 (OPC-DIO) *5 *4027(5027): Digital input I7 (OPC-DIO) *5 *4028(5028): Digital input I8 (OPC-DIO) *5 *4029(5029): Digital input I9 (OPC-DIO) *5 *4030(5030): Digital input I10 (OPC-DIO) *5 *4031(5031): Digital input I11 (OPC-DIO) *5 *4032(5032): Digital input I12 (OPC-DIO) *5 *4033(5033): Digital input I13 (OPC-DIO) *5 6000 (7000): Final run command RUN "FL_RUN" 6001 (7001): Final run command FWD "FL_FWD" 6002 (7002): Final run command REV "FL_REV" 6003 (7003): Accelerating "DACC" 6004 (7004): Decelerating "DDEC" 6005 (7005): Under anti-regenerative control "REGA" 6006 (7006): Within dancer reference position "DR_REF" 6007 (7007): With/without alarm factor "ALM_ACT" * Inside the () is the negative logic signal. (OFF at short-circuit) [Analog] 8000 to 8021: The value with 8000 added to F31 9001: Analog 12 terminal input signal [12] 9002: Analog C1 terminal input signal [C1] (C1) 9003: Analog V2 terminal input signal [C1] (V2) *9004: Analog 32 terminal input signal [32] *5 *9005: Analog C2 terminal input signal [C2] *5	N	Y	100	Y	Y	Y	Y	Y	
U04	(Function 1)	-9990 to 0.00 to 9990	N	Y	0.00	Y	Y	Y	Y	Y	
U05	(Function 2)		N	Y	0.00	Y	Y	Y	Y	Y	

*: The use of the option card lets those functions remain in effect.
 *5: Available at ROM version 0300 or later.

Customizable logic Step 1 to 14 function code is assigned as follows: Setting value is the same as U01 to U05.

Block selection	Step1	Step2	Step3	Step4	Step5	Step6	Step7	Step8	Step9	Step10
Input 1	U01	U06	U11	U16	U21	U26	U31	U36	U41	U46
Input 2	U02	U07	U12	U17	U22	U27	U32	U37	U42	U47
Function 1	U03	U08	U13	U18	U23	U28	U33	U38	U43	U48
Function 2	U04	U09	U14	U19	U24	U29	U34	U39	U44	U49
	U05	U10	U15	U20	U25	U30	U35	U40	U45	U50
Block selection	Step11	Step12	Step13	Step14						
Input 1	U51	U56	U61	U66						
Input 2	U52	U57	U62	U67						
Function 1	U53	U58	U63	U68						
Function 2	U54	U59	U64	U69						
	U55	U60	U65	U70						

5.2 Function Codes Table

Code	Name	Data setting range	Change when running	Data copying	Factory Default	Drive control					Related page
						V/f	PG V/f	w/PG	Torque control	PM	
U71	Customizable logic (Output selection) Output signal 1	0: Disable 1 to 200: Output of Step 1 to 200 "S001" to "S0200"	N	Y	0	Y	Y	Y	Y	Y	
U72	Output signal 2		N	Y	0	Y	Y	Y	Y	Y	
U73	Output signal 3		N	Y	0	Y	Y	Y	Y	Y	
U74	Output signal 4		N	Y	0	Y	Y	Y	Y	Y	
U75	Output signal 5		N	Y	0	Y	Y	Y	Y	Y	
U76	Output signal 6		N	Y	0	Y	Y	Y	Y	Y	
U77	Output signal 7		N	Y	0	Y	Y	Y	Y	Y	
U78	Output signal 8		N	Y	0	Y	Y	Y	Y	Y	
U79	Output signal 9		N	Y	0	Y	Y	Y	Y	Y	
U80	Output signal 10		N	Y	0	Y	Y	Y	Y	Y	
U81	Customizable logic (Function selection) Output signal 1	0 to 172 (1000 to 1172): Same as E01 8001 to 8020: The value with 8000 added to E61	N	Y	100	Y	Y	Y	Y	Y	
U82	Output signal 2		N	Y	100	Y	Y	Y	Y	Y	
U83	Output signal 3		N	Y	100	Y	Y	Y	Y	Y	
U84	Output signal 4		N	Y	100	Y	Y	Y	Y	Y	
U85	Output signal 5		N	Y	100	Y	Y	Y	Y	Y	
U86	Output signal 6		N	Y	100	Y	Y	Y	Y	Y	
U87	Output signal 7		N	Y	100	Y	Y	Y	Y	Y	
U88	Output signal 8		N	Y	100	Y	Y	Y	Y	Y	
U89	Output signal 9		N	Y	100	Y	Y	Y	Y	Y	
U90	Output signal 10		N	Y	100	Y	Y	Y	Y	Y	
U91	Customizable logic timer monitor (Step selection)	0: Monitor disable 1 to 200: Step 1 to 200	Y	N	0	Y	Y	Y	Y	Y	
U92	Customizable logic (The coefficients of the approximate formula) (Mantissa of KA1)	-9.999 to 9.999	N	Y	0.000	Y	Y	Y	Y	Y	
U93	(Exponent part of KA1)	-5 to 5	N	Y	0	Y	Y	Y	Y	Y	
U94	(Mantissa of KB1)	-9.999 to 9.999	N	Y	0.000	Y	Y	Y	Y	Y	
U95	(Exponent part of KB1)	-5 to 5	N	Y	0	Y	Y	Y	Y	Y	
U96	(Mantissa of KC1)	-9.999 to 9.999	N	Y	0.000	Y	Y	Y	Y	Y	
U97	(Exponent part KC1)	-5 to 5	N	Y	0	Y	Y	Y	Y	Y	
U100	Task process cycle setting	0: Auto select from 2, 5, 10 or 20 ms depending on the number of steps 2: 2 ms (Up to 10 step) 5: 5 ms (Up to 50 step) 10: 10 ms (Up to 100 step) 20: 20ms (Up to 200 step) *5	N	Y	0	Y	Y	Y	Y	Y	
U101	Customizable logic (Operating point 1 (X1))	-999.00 to 0.00 to 9990.00	Y	Y	0.00	Y	Y	Y	Y	Y	5-250 5-273
U102	(Operating point 1 (Y1))		Y	N		Y	Y	Y	Y	Y	
U103	(Operating point 2 (X2))		Y	N		Y	Y	Y	Y	Y	
U104	(Operating point 2 (Y2))		Y	N		Y	Y	Y	Y	Y	
U105	(Operating point 3 (X3))		Y	N		Y	Y	Y	Y	Y	
U106	(Operating point 3 (Y3))		Y	N		Y	Y	Y	Y	Y	
U107	Customizable logic (Auto calculation of the coefficients of the approximate formula)	0: Invalid 1: Execute calculation (When the calculation is finished, the results are stored to the function code U92 to U97)	N	N	0	Y	Y	Y	Y	Y	5-250 5-274

5.2 Function Codes Table

Code	Name	Data setting range	Change when running	Data copying	Factory Default	Drive control					Related page
						V/f	PG V/f	w/PG	Torque control	PM	
U121	Customizable logic (User parameter 1)	-9990.00 to 0.00 to 9990.00	Y	Y	0.00	Y	Y	Y	Y	Y	5-250
U122	(User parameter 2)					Y	Y	Y	Y	Y	
U123	(User parameter 3)					Y	Y	Y	Y	Y	
U124	(User parameter 4)					Y	Y	Y	Y	Y	
U125	(User parameter 5)					Y	Y	Y	Y	Y	
U126	(User parameter 6)					Y	Y	Y	Y	Y	
U127	(User parameter 7)					Y	Y	Y	Y	Y	
U128	(User parameter 8)					Y	Y	Y	Y	Y	
U129	(User parameter 9)					Y	Y	Y	Y	Y	
U130	(User parameter 10)					Y	Y	Y	Y	Y	
U131	(User parameter 11)					Y	Y	Y	Y	Y	
U132	(User parameter 12)					Y	Y	Y	Y	Y	
U133	(User parameter 13)					Y	Y	Y	Y	Y	
U134	(User parameter 14)					Y	Y	Y	Y	Y	
U135	(User parameter 15)					Y	Y	Y	Y	Y	
U136	(User parameter 16)					Y	Y	Y	Y	Y	
U137	(User parameter 17)					Y	Y	Y	Y	Y	
U138	(User parameter 18)					Y	Y	Y	Y	Y	
U139	(User parameter 19)					Y	Y	Y	Y	Y	
U140	(User parameter 20)					Y	Y	Y	Y	Y	
U171	Customizable logic (Storage area 1)	-9990.00 to 0.00 to 9990.00	Y	Y	0.00	Y	Y	Y	Y	Y	
U172	(Storage area 2)					Y	Y	Y	Y	Y	
U173	(Storage area 3)					Y	Y	Y	Y	Y	
U174	(Storage area 4)*5					Y	Y	Y	Y	Y	
U175	(Storage area 5)*5					Y	Y	Y	Y	Y	
U190	Customizable logic setting step (Step number)	1 to 200	Y	Y	15	Y	Y	Y	Y	Y	
U191	Setting step (Select block)	Same as U01	N	Y	0	Y	Y	Y	Y	Y	
U192	(Input 1)	Same as U02	N	Y	100	Y	Y	Y	Y	Y	
U193	(Input 2)	Same as U03	N	Y	100	Y	Y	Y	Y	Y	
U194	(Function 1)	Same as U04	N	Y	0.00	Y	Y	Y	Y	Y	
U195	(Function 2)	Same as U05	N	Y	0.00	Y	Y	Y	Y	Y	
U196	Customizable logic ROM version Upper digit (Monitor)	0 to 9999	N	N	0	Y	Y	Y	Y	Y	
U197	Customizable logic ROM version Upper digit (For User setting)	0 to 9999	N	Y	0	Y	Y	Y	Y	Y	
U198	Customizable logic ROM version Lower digit (Monitor)	0 to 9999	N	N	0	Y	Y	Y	Y	Y	
U199	Customizable logic ROM version Lower digit (For User setting)	0 to 9999	N	Y	0	Y	Y	Y	Y	Y	

*5: Available at ROM version 0300 or later.

■ y codes: LINK Functions (Link function)

Code	Name	Data setting range	Change when running	Data copying	Factory Default	Drive control					Related page
						V/f	PG V/f	w/PG	Torque control	PM	
y01	RS-485 Communication 1 (Station address)	1 to 255	N	Y	1	Y	Y	Y	Y	Y	5-277
y02	(Communications error processing)	0: Immediately trip with alarm E_r-B 1: Trip with alarm E_r-B after running for the period specified by timer y03 2: Retry during the period specified by timer y03. If the retry fails, trip with alarm E_r-B . If it succeeds, continue to run. 3: Continue to run	Y	Y	0	Y	Y	Y	Y	Y	
y03	(Timer)	0.0 to 60.0 s	Y	Y	2.0	Y	Y	Y	Y	Y	
y04	(Baud rate)	0: 2400 bps 1: 4800 bps 2: 9600 bps 3: 19200 bps 4: 38400 bps	Y	Y	3	Y	Y	Y	Y	Y	
y05	(Data length selection)	0: 8 bit 1: 7 bits	Y	Y	0	Y	Y	Y	Y	Y	
y06	(Parity selection)	0: None (Stop bit: 2 bits) 1: Even number parity (Stop bit: 1 bits) 2: Odd number parity (Stop bit: 1 bits) 3: None (Stop bit: 1 bits)	Y	Y	0	Y	Y	Y	Y	Y	
y07	(Stop bit selection)	0: 2 bits 1: 1 bits	Y	Y	0	Y	Y	Y	Y	Y	
y08	(Communication time-out detection timer)	0: Not check of the time-out 1 to 60 s	Y	Y	0	Y	Y	Y	Y	Y	
y09	(Response interval time)	0.00 to 1.00 s	Y	Y	0.01	Y	Y	Y	Y	Y	
y10	(Protocol selection)	0: Modbus RTU protocol 1: FRENIC Loader protocol (SX protocol) 2: Fuji general-purpose inverter protocol	Y	Y	1	Y	Y	Y	Y	Y	
y11	RS-485 Communication 2 (Station address)	1 to 255	N	Y	1	Y	Y	Y	Y	Y	
y12	(Communications error processing)	0: Immediately trip with alarm E_r-P 1: Trip with alarm E_r-P after running for the period specified by timer y13 2: Retry during the period specified by timer y13. If the retry fails, trip with alarm E_r-P . If it succeeds, continue to run. 3: Continue to run	Y	Y	0	Y	Y	Y	Y	Y	
y13	(Timer)	0.0 to 60.0 s	Y	Y	2.0	Y	Y	Y	Y	Y	
y14	(Baud rate)	0: 2400 bps 1: 4800 bps 2: 9600 bps 3: 19200 bps 4: 38400 bps	Y	Y	3	Y	Y	Y	Y	Y	
y15	(Data length selection)	0: 8 bits 1: 7 bits	Y	Y	0	Y	Y	Y	Y	Y	
y16	(Parity selection)	0: None (Stop bit: 2 bits) 1: Even number parity (Stop bit: 1 bits) 2: Odd number parity (Stop bit: 1 bits) 3: None (Stop bit: 1 bits)	Y	Y	0	Y	Y	Y	Y	Y	
y17	(Stop bit selection)	0: 2 bits 1: 1 bit	Y	Y	0	Y	Y	Y	Y	Y	
y18	(Communication time-out detection timer)	0: Not check of the time-out 1 to 60 s	Y	Y	0	Y	Y	Y	Y	Y	
y19	(Response interval time)	0.00 to 1.00 s	Y	Y	0.01	Y	Y	Y	Y	Y	
y20	(Protocol selection)	0: Modbus RTU protocol 1: FRENIC Loader protocol (SX protocol) 2: Fuji general-purpose inverter protocol	Y	Y	0	Y	Y	Y	Y	Y	

5.2 Function Codes Table

Code	Name	Data setting range	Change when running	Data copying	Factory Default	Drive control					Related page
						V/f	PG V/f	w/PG	Torque control	PM	
y21	Built-in CAN communication (Node ID)	1 to 127	N	Y	1	Y	Y	Y	Y	Y	5-280
y24	(Baud rate)	0: 125kbps 1: 20kbit/s 2: 50kbit/s 3: 125kbit/s 4: 250kbit/s 5: 500kbit/s 6: 800kbit/s 7: 1Mbit/s	N	Y	0	Y	Y	Y	Y	Y	
y25	Map the inverter function code1 to RPDO No. 3	0000 to FFFF (in hexadecimal) Data mapped I/O (Write)	N	Y	0000	Y	Y	Y	Y	Y	
y26	Map the inverter function code2 to RPDO No. 3					Y	Y	Y	Y	Y	
y27	Map the inverter function code3 to RPDO No. 3					Y	Y	Y	Y	Y	
y28	Map the inverter function code4 to RPDO No. 3					Y	Y	Y	Y	Y	
y29	Map the inverter function code1 to TPDO No. 3					Y	Y	Y	Y	Y	
y30	Map the inverter function code2 to TPDO No. 3					Y	Y	Y	Y	Y	
y31	Map the inverter function code3 to TPDO No. 3					Y	Y	Y	Y	Y	
y32	Map the inverter function code4 to TPDO No. 3					Y	Y	Y	Y	Y	
y33	(Operation selection)	0: Disable, 1: Enable	Y	Y	0	Y	Y	Y	Y	Y	
y34	(Communications error processing)	This function code is valid in case of y36=-4 or -5. 1: After the time specified by [y35], coast to a stop and trip with [ert]. 2: If the inverter receives any data within the time specified by [y35], ignore the communications error. After the timeout, coast to a stop and trip with [ert]. 10: Immediately decelerate to a stop. Issue [ert] after stopping. 11: After the time specified by [y35], decelerate to a stop. Issue [ert] after stopping. 12: If the inverter receives any data within the time specified by [y35], ignore the communications error. After the timeout, decelerate to a stop and trip with [ert]. Otherwise: Immediately coast to a stop and trip with [ert].	Y	Y	0	Y	Y	Y	Y	Y	
y35	(Communication time-out detection timer)	0.0 to 60.0	Y	Y	0.0	Y	Y	Y	Y	Y	
y36	(Operation selection in abort status) *5	-5 to 3	Y	Y	1	Y	Y	Y	Y	Y	
y95	Data clear processing for communications error	0: Do not clear the data of function codes Sxx when a communications error occurs. (compatible with the conventional inverters) 1: Clear the data of function codes S01/S05/S19 when a communications error occurs. 2: Clear the run command assigned bit of function code S06 when a communications error occurs. 3: Clear both data of S01/S05/S19 and run command assigned bit of S06 when a communications error occurs. * Related alarms: <i>E-r-B, E-r-P, E-r-4, E-r-5, E-r-t</i>	Y	Y	0	Y	Y	Y	Y	Y	5-280
y97	Communication data storage selection	0: Store into nonvolatile memory (Rewritable times are limited) 1: Write into temporary memory (Rewritable times are unlimited) 2: Save all data from temporary memory to nonvolatile memory (After all save, return to Data 1)	Y	Y	0	Y	Y	Y	Y	Y	5-280
y98	Bus link function (Mode selection)	Frequency command Run command 0: Follow H30 Follow H30 1: Bus link Follow H30 2: Follow H30 Bus link 3: Bus link Bus link	Y	Y	0	Y	Y	Y	Y	Y	5-280
y99	Loader link function (Mode selection)	Frequency command Run command 0: Follow H30, y98 Follow H30, y98 1: FRENIC loader Follow H30, y98 2: Follow H30, y98 FRENIC loader 3: FRENIC loader FRENIC loader	Y	N	0	Y	Y	Y	Y	Y	5-281

*5: Available at ROM version 0300 or later.

■ K codes: Keypad functions for TP-A1-E2C

Code	Name	Data setting range	Change when running	Data copying	Factory Default	Drive control					Related page
						V/f	PG V/f	w/PG	Torque control	PM	
K01	Multifunction keypad TP-A1-E2C (Language selection)	0: Japanese 1: English 2: German 3: French 4: Spanish 5: Italian 6: Chinese 8: Russian 9: Greek 10: Turkish 11: Polish 12: Czech 13: Swedish 14: Portuguese 15: Dutch 16: Malay 17: Vietnamese 18: Thai 19: Indonesian 100: User-Customizable language	Y	Y	J: 0 C: 6 AEUK: 1	Y	Y	Y	Y	Y	-
K02	(Backlight OFF time)	0: Always OFF 1 to 30 min	Y	Y	5	Y	Y	Y	Y	Y	-
K03	(Backlight brightness adjustment)	0 (dark) - 10 (bright)	Y	Y	5	Y	Y	Y	Y	Y	-
K04	(Contrast adjustment)	0 (low) - 10 (high)	Y	Y	5	Y	Y	Y	Y	Y	-
K08	(LCD monitor status display)	0: Not displayed 1: Fully displayed	Y	Y	1	Y	Y	Y	Y	Y	-
K15	(Sub-monitor display selection)	0: Operation guide display 1: Bar graph display	Y	Y	0	Y	Y	Y	Y	Y	-
K16	(Sub-monitor 1 display selection)	1 to 35	Y	Y	13	Y	Y	Y	Y	Y	-
K17	(Sub-monitor 2 display selection)	1: Output frequency 1 (before slip compensation) 2: Output frequency 2 (after slip compensation) 3: Reference frequency 4: Motor rotation speed 5: Load rotation speed 6: Line speed 7: Transport time for specified length 8: Speed (%) 13: Output current 14: Output voltage 18: Calculated torque 19: Input power 25: Load factor 26: Motor output 27: Analog input monitor 31: Current position pulse 32: Position error pulse 33: Torque current (%) 34: Magnetic flux command (%) 35: Input watt-hour	Y	Y	19	Y	Y	Y	Y	Y	-
K20	(Bar graph 1 display selection)	1: Output frequency 1 (before slip compensation) 13: Output current 14: Output voltage	Y	Y	1	Y	Y	Y	Y	Y	-
K21	(Bar graph 2 display selection)	18: Calculated torque 19: Input power	Y	Y	13	Y	Y	Y	Y	Y	-
K22	(Bar graph 3 display selection)	25: Load factor 26: Motor output	Y	Y	19	Y	Y	Y	Y	Y	-
K91	(< key shortcut selection)	0: disabled	Y	Y	0	Y	Y	Y	Y	Y	-
K92	(> key shortcut selection)	11 to 99: respective mode	Y	Y	64	Y	Y	Y	Y	Y	-

The keypad function K codes are used when the multi-function keypad (TP-A1-E2C) is connected. For details about the K codes, refer to the instruction manual for the keypad.

5.2.3 Factory default value per applicable electric motor capacitance

Applicable electric motor capacity		Torque boost 1 to 2 F09/ A05	Restart mode after momentary power failure (Restart timer) H13
kW	HP		
0.1	1/8	6.7	0.5
0.2	1/4	4.0	
0.4	1/2	3.5	
0.75	1	6.5	
1.5	2	4.9	
2.2	3	4.5	
3.7	5	4.1	
5.5	7.5	3.4	
7.5	10	2.7	
11	15	2.1	
15	20	1.6	
18.5	25	1.3	
22	30	1.1	
30	40	0.0	
37	50		
45	60		0.0
55	75	1.5	
75	100		
90	125		
110	150		
132	175		
160	200	2.0	
200	250		
220	300	2.5	
280	400		
315	450		4.0
355	500		

Chapter 6 TROUBLESHOOTING

6.1 Protective Function

In order to prevent system down or to shorten a downtime, FRENIC-Ace is provided with various protective functions shown in Table 6.1-1 below. The protective functions marked with an asterisk (*) in the table are disabled by factory default. Enable them according to your needs.

The protective functions include, for example, the “heavy alarm” detection function which, upon detection of an abnormal state, displays the alarm code on the LED monitor and causes the inverter to trip, the “light alarm” detection function which displays the alarm code but lets the inverter continue the current operation, and other warning signal output functions.

If any problem arises, understand the protective functions listed below and follow the procedures given in Sections 6.2 and onwards for troubleshooting.

Table 6.1-1 Abnormal States Detectable (“Heavy Alarm” and “Light Alarm” Objects)

Protective function	Description	Related function code
“Heavy alarm” detection	This function detects an abnormal state, displays the corresponding alarm code, and causes the inverter to trip. See “Table 6.3-1 Various failure detections (Heavy failure objects)” for alarm codes. For details of each alarm code, see the corresponding item in the troubleshooting in the FRENIC-Ace User’s Manual, Section 6.3 . The inverter retains the last four alarm codes and their factors together with their running information applied when the alarm occurred, so it can display them.	H98
“Light alarm” detection*	This function detects an abnormal state categorized as a “light alarm,” displays $L-FLL$ and lets the inverter continue the current operation without tripping. Details of light alarms are selectable. Selectable details (codes) are shown in “Table 6.3-1 Various failure detections (Heavy failure objects).” See the FRENIC-Ace User’s Manual, Section 6.4 for the confirming method and releasing method of the light alarms.	H81 H82
Stall prevention	When the output current exceeds the current limiter level (F44) during acceleration/ deceleration or constant speed running, this function decreases the output frequency to avoid an overcurrent trip.	F44
Overload prevention control*	Before the inverter trips due to a cooling fin overheat (LHI) or inverter overload (LLO), this function decreases the output frequency of the inverter to reduce the load.	H70
Anti-regenerative control*	If regenerative energy returned exceeds the inverter’s braking capability, this function automatically increases the deceleration time or controls the output frequency to avoid an overvoltage trip.	H69
Deceleration characteristics* (Improvement of braking performance)	During deceleration, this function increases the motor energy loss and decreases the regenerative energy returned to avoid an overvoltage trip (LLO).	H71
Reference loss detection*	This function detects a frequency reference loss (due to a broken wire, etc.), issues the alarm, and continues the inverter operation at the specified frequency.	E65
Automatic lowering of carrier frequency	Before the inverter trips due to an abnormal surrounding temperature or output current, this function automatically lowers the carrier frequency to avoid a trip.	H98
Motor overload early warning*	When the inverter output current has exceeded the specified level, this function issues the “Motor overload early warning” signal before the thermal overload protection function causes the inverter to trip for motor protection (Only for the 1st motor).	E34 E35
Retry*	When the inverter has stopped because of a trip, this function allows the inverter to automatically reset and restart itself. The number of retries and the latency between stop and reset can be specified.	H04 H05
Forced stop*	Upon receipt of the “Force to stop” terminal command STOP, this function interrupts the run and other commands currently applied in order to forcedly decelerate the inverter to a stop state.	H56
Surge protection	This function protects the inverter from a surge voltage between main circuit power lines and the ground.	-
Momentary power failure protection*	<ul style="list-style-type: none"> If a momentary power failure for 15 ms or longer occurs, a protective operation (inverter stop) is activated. When momentary power failure restart is selected, the inverter restarts automatically after voltage restoration within a set-up time (momentary power failure permissible time). 	F14

6.2 Before Proceeding with Troubleshooting

⚠ WARNING

- If any of the protective functions has been activated, first remove the cause. Then, after checking that all run commands are set to OFF, release the alarm. If the alarm is released while any run command is set to ON, the inverter may supply the power to the motor, running the motor.

Injury may occur.

- Even though the inverter has interrupted power to the motor, if the voltage is applied to the main circuit input terminals L1/R, L2/S, L3/T, L1/L and L2/N, voltage may be output to inverter output terminals U, V, and W.
- Turn OFF the power and wait for at least five minutes for inverters with a capacity of FRN0011E2■-7□ / FRN0115E2■-2□ / FRN0072E2■-4□ or below, or at least ten minutes for inverters with a capacity of FRN0085E2■-4□ or above. Make sure that the LED monitor or charging lamp are turned OFF. Further, make sure, using a multimeter or a similar instrument, that the DC intermediate circuit voltage between the terminals P (+) and N (-) has dropped to the safe level (+25 VDC or below).

Electric shock may occur.

Follow the procedure below to solve problems.

As for Section 6.4 and later referenced below, please refer to Chapter 6 “TROUBLESHOOTING” of the User's Manual.

- (1) Is wire connection correct?
See Chapter 2 “2.2.1 Basic connection diagram.”
- (2) Check whether an alarm code or the “light alarm” indication (I-al) is displayed on the LED monitor.
 - If an Alarm Code Appears on the LED Monitor To Section 6.3
 - If the “Light Alarm” Indication ($\angle -\overline{FL}$) Appears on the LED Monitor To Section 6.4
 - When Codes Other Than Alarm Codes and Light Alarm Indication ($\angle -\overline{FL}$) are Displayed To Section 6.5

Abnormal motor operation To Section 6.5.1

- 6.5.1 [1] The motor does not rotate
- 6.5.1 [2] The motor rotates, but the speed does not increase
- 6.5.1 [3] The motor runs in the opposite direction to the command
- 6.5.1 [4] Speed fluctuation or current oscillation (e.g., hunting) occurs during running at constant speed
- 6.5.1 [5] Unpleasant noises are emitted from motor or noises fluctuate
- 6.5.1 [6] Motor is not accelerated or decelerated according to set-up acceleration or deceleration times
- 6.5.1 [7] The motor does not restart even after the power recovers from a momentary power failure
- 6.5.1 [8] Motor generates heat abnormally
- 6.5.1 [9] The motor does not run as expected
- 6.5.1 [10] Motor stalls during acceleration

Problems with inverter settings To Section 6.5.2

- 6.5.2 [1] Nothing appears on the LED monitor
- 6.5.2 [2] The desired menu is not displayed
- 6.5.2 [3] Display of under bars (_ _ _ _)
- 6.5.2 [4] Display of center bars (- - - -)
- 6.5.2 [5] $\angle \quad \overline{\quad}$ Display of parenthesis
- 6.5.2 [6] Data of function codes cannot be changed

If any problems persist after the above recovery procedure, contact your Fuji Electric representative.

6.3 If an Alarm Code Appears on the LED Monitor

6.3.1 Alarm code list

When an alarm is detected, check the alarm code displayed on 7-segment LED of keypad.

When one alarm code has more than one cause, alarm subcodes are provided to make it easy to identify the cause. When there is only one cause, the alarm subcode is displayed as “-” and described as “-.”

- * See the FRENIC-Ace User's Manual, Chapter 3 “3.4.6 Reading alarm information” for the method of checking the alarm codes.
- * With regard to alarm details having alarm subcodes name “For manufacturer”, inform the alarm subcodes, too, when contacting Fuji Electric or requesting an inverter repair.

Table 6.3-1 Various failure detections (Heavy failure objects)

Alarm code	Alarm code name	Heavy failure object	Light alarm selectable	Retry object	Alarm subcode*	Alarm subcode name	Reference page
<i>EoF</i>	PID feedback wire break	Y	Y	—	—	—	6-7
<i>dbR</i>	Braking transistor broken	Y	—	—	—	—	6-7
<i>dbH</i>	Braking resistor overheat (FRN0115E2■-2□ or below /FRN0011E2■-7□ or below /FRN0072E2■-4□ or below)	Y	Y	Y	0	DB resistor overheat	6-7
					1	For manufacturer	
<i>EEF</i>	EN circuit failure	Y	—	—	10	ASIC alarm for functional safety	6-8
					3000	Erroneous detection of STO input	
					Other than above	For manufacturer	
<i>EEL</i>	Customizable logic failure	Y	—	—	—	—	—
<i>EF</i>	Ground fault (FRN0085E2■-4□ or above)	Y	—	—	—	—	6-8
<i>Er1</i>	Memory error	Y	—	—	1 to 16	For manufacturer	6-8
<i>Er2</i>	Keypad communications error	Y	—	—	1 to 2	For manufacturer	6-9
<i>Er3</i>	CPU error	Y	—	—	1 to 9000	For manufacturer	6-9
<i>Er4</i>	Option communications error	Y	Y	—	1	For manufacturer	6-9
<i>Er5</i>	Option error	Y	Y	—	0	Time-out	6-9
					1 to 10	For manufacturer	
<i>Er6</i>	Operation error	Y	—	—	1	STOP key priority/forced stop (STOP terminal)	6-10
					2	Start check function	
					3	Start check function (when operation is permitted)	
					4	Start check function (when reset is turned on)	
					5	Start check function (when the power recovers in powering on)	
					6	Start check function (TP connection)	
8 to 14	For manufacturer						

See page shows the page of the user's manual.

6.3 If an Alarm Code Appears on the LED Monitor

Continuation of Table 6.3-1

Alarm code	Alarm code name	Heavy failure object	Light alarm selectable	Retry object	Alarm subcode*	Alarm subcode name	Reference page
<i>E-r7</i>	Tuning error	Y	—	—	7	Operation command OFF during motor tuning	6-10
					8	Forced stop during motor tuning	
					9	BX command during motor tuning	
					10	Hardware current limit during motor tuning	
					11	Occurrence of low voltage (LV) during motor tuning	
					12	Failure due to prevention of reverse rotation during motor tuning	
					13	Over upper limit frequency during motor tuning	
					14	Switching to commercial power during motor tuning	
					15	Occurrence of alarm during motor tuning	
					16	Change of run command source during motor tuning	
					18	Over acceleration time during motor tuning	
					24	EN terminal failure during motor tuning	
					5000 to 5065	Refer to Chapter 4 “4.8.2 Alarm Information”	
					Other than above	For manufacturer	
<i>E-r8</i>	RS-485 communications error (Communication port 1)	Y	Y	—	—	—	6-11
<i>E-rd</i>	Step-out detection	Y	—	—	5001 to 5008	For manufacturer	6-12
<i>E-rE</i>	Speed inconsistency/ excessive speed deviation	Y	Y	—	1	Signs of speed command and speed detection are inconsistent.	6-13
					3	In the case of excessive speed deviation (detected speed > speed command)	
					5	Detected speed remains 0Hz irrespective of speed command.	
					7	In the case of excessive speed deviation (detected speed < speed command)	
<i>E-rF</i>	Data saving error during undervoltage	Y	—	—	—	—	6-14
<i>E-rH</i>	Hardware error	Y	—	—	—	—	6-14
<i>E-ro</i>	Positioning control error	Y	Y	—	1 to 5	For manufacturer	6-14
<i>E-rP</i>	RS-485 communications error (Communication port 2)	Y	Y	—	—	—	6-12
<i>E-rr</i>	Simulated failure	Y	—	—	—	—	6-15
<i>E-rt</i>	CAN communications failure	Y	—	—	1 to 2	For manufacturer	6-15
<i>F-uS</i>	DC fuse-blowing	Y	—	—	—	—	6-15
<i>L-in</i>	Input phase loss	Y	—	—	1-2	For manufacturer	6-16
<i>LU</i>	Undervoltage	Y	—	—	1	Occurrence of low voltage during gate ON (F14=0)	6-16
					2	Run command ON during low voltage (F14=0, 2)	
					3	LV trip on power recovery from a momentary power failure (F14=1)	
					4 to 5	For manufacturer	

See page shows the page of the user's manual.

6.3 If an Alarm Code Appears on the LED Monitor

Continuation of Table 6.3-1



Alarm code	Alarm code name	Heavy failure object	Light alarm selectable	Retry object	Alarm subcode*	Alarm subcode name	Reference page
<i>OC1</i>	Instantaneous overcurrent	Y	—	Y	1 to 5001	For manufacturer	6-17
<i>OC2</i>							
<i>OC3</i>							
<i>OH1</i>	Cooling fin overheat	Y	Y	Y	6	Detection of fan stop	6-18
					Other than above	For manufacturer	
<i>OH2</i>	External alarm	Y	Y	—	—	—	6-18
<i>OH3</i>	Inverter internal overheat	Y	Y	Y	0	Internal air overheat	6-18
					1	Charging resistor overheat	
					Other than above	For manufacturer	
<i>OH4</i>	Motor protection (PTC thermistor)	Y	—	Y	—	—	6-19
<i>OH6</i>	Charging resistor overheat	Y	Y	Y	—	—	6-19
<i>OL1</i>	Motor 1 overload	Y	Y	Y	—	—	6-20
<i>OL2</i>	Motor 2 overload	Y	Y	Y	—	—	
<i>OLU</i>	Inverter overload	Y	—	Y	1	IGBT protection	6-21
					2	Inverter overload	
					10	For manufacturer	
<i>OPL</i>	Output phase-failure detection	Y	—	—	1 to 10	For manufacturer	6-21
<i>OS</i>	Overspeed protection	Y	—	—	—	—	6-22
<i>OU1</i>	Overvoltage	Y	—	Y	1 to 12	For manufacturer	6-22
<i>OU2</i>							
<i>OU3</i>							
<i>PBF</i>	Charger circuit fault (FRN0203E2 ■-4□ or above)	Y	—	—	1 to 2	For manufacturer	6-23
<i>PG</i>	PG wire break	Y	—	—	10 to 20	For manufacturer	6-23
<i>INF</i>	Inverter life (Number of startups)	—	Y	—	—	—	6-24
<i>FAL</i>	Detect DC fan lock	—	Y	—	—	—	
<i>LIF</i>	Lifetime alarm	—	Y	—	—	—	
<i>OH</i>	Cooling fin overheat early warning	—	Y	—	—	—	
<i>OL</i>	Overload early warning	—	Y	—	—	—	
<i>PID</i>	PID alarm output	—	Y	—	—	—	
<i>PTC</i>	PTC thermistor activated	—	Y	—	—	—	
<i>REF</i>	Reference command loss detected	—	Y	—	—	—	
<i>RE</i>	Machine life (Cumulative motor running hours)	—	Y	—	—	—	
<i>LFL</i>	Low torque detection	—	Y	—	—	—	

- NB) • If a control power supply voltage drops to such a level that the operation of the inverter control circuit cannot be maintained, all protective functions are automatically reset.
- By OFF → ON operation of  key or X terminal (assigned to RST) the protection stop state can be released. In a state that an alarm cause is not removed, however, resetting operation is not effective.
 - If two or more alarms are occurring, the resetting operation remains ineffective until all the alarm causes are removed. Alarm factors not removed can be checked from the keypad.
 - When assigned to light alarms, “30A/B/C” do not work.

See page shows the page of the user's manual.

Chapter 7 MAINTENANCE AND INSPECTION

Perform daily and periodic inspections to avoid trouble and keep reliable operation of the inverter for a long time. When performing inspections, follow the instructions given in this chapter.

 WARNING 
<ul style="list-style-type: none"> • Before proceeding to the maintenance/inspection jobs, turn OFF the power and wait at least five minutes for inverters FRN0115E2■-2□ / FRN0072E2■-4□ / FRN0011E2■-7□ or below, or at least ten minutes for inverters FRN0085E2■-4□ or above. Make sure that the LED monitor / charging lamp are turned OFF. Further, make sure, using a multimeter or a similar instrument, that the DC link bus voltage between the terminals P(+) and N(-) has dropped to the safe level (+25 VDC or below). <p>Electric shock may occur.</p> <ul style="list-style-type: none"> • Maintenance, inspection, and parts replacement should be made only by authorized persons. • Take off the watch, rings and other metallic objects before starting work. • Use insulated tools. • Never modify the inverter. <p>Electric shock or injuries could occur.</p>

7.1 Inspection Interval

Table 7.1-1 lists the inspection intervals and check items, as a guide.

Table 7.1-1 List of Inspections

Inspection type	Inspection interval	Check items
Daily inspection	Every day	See Section 7.2 .
Periodic inspection	Every year	See Section 7.3 .
Decennial inspection *1	Every 10 years *2	Replacement of cooling fans *3 Replacement of DC link bus capacitors and close checks

*1 The decennial inspection (except replacement of cooling fans) should be performed only by the persons who have finished the Fuji Electric training course. Contact the sales agent where you purchased the product or your nearest Fuji Electric representative.

*2 Every 7 years for ND-mode inverters.

*3 For the standard replacement interval of cooling fans, refer to "7.4 List of Periodic Replacement Parts."

 **Note** The replacement intervals are based on the inverter's service life estimated at an ambient temperature of 40°C at 100% (HHD-mode inverters) or 80% (ND-/HD-/HND-mode inverters) of full load. In environments with an ambient temperature above 40°C or a large amount of dust or dirt, the replacement intervals may be shorter.

Standard replacement intervals mentioned above are only a guide for replacement, not a guaranteed service life. Refer to "7.4 List of Periodic Replacement Parts."

7.2 Daily Inspection

Visually inspect the inverter for operation errors from the outside without removing the covers when the inverter is running or the power is ON.

Table 7.2-1 lists daily inspection items.

Table 7.2-1 Daily Inspection List

Check part	Check item	How to inspect	Evaluation criteria
Environment	1) Check the surrounding temperature, humidity, vibration and atmosphere (dust, gas, oil mist, or water drops). 2) Check that tools or other foreign materials or dangerous objects are not left around the equipment.	1) Check visually or measure using apparatus. 2) Visual inspection	1) The usage environment given in Chapter 1, Section 1.3.1 must be satisfied. 2) No foreign or dangerous objects are left.
External appearance and others	1) Check that the bolts securing the wires to the main circuit terminals and control circuit terminals are not loose <u>before turning the power ON</u> . 2) Check for traces of overheat, discoloration and other defects. 3) Check for abnormal noise, odor, or excessive vibration.	1) Retighten <u>before turning the power ON</u> . 2) Visual inspection 3) Auditory, visual, and olfactory inspection	1) No loose screws. If loose, retighten the screws. 2), 3) No abnormalities
Cooling fans	Check for abnormal noise or excessive vibration when the cooling fans are in operation.	Auditory and visual inspections	No abnormalities
Keypad	Check for alarm indication.	Visual inspection	If any alarm is displayed, refer to Chapter 6.
Performance	Check that the inverter provides the expected performance (as defined in the standard specifications).	Check the monitor items shown on the keypad.	No abnormalities in the output speed, current and voltage and other running data.

7.3 Periodic Inspection

7.3.1 Periodic inspection 1--Before the inverter is powered ON or after it stops running

Perform periodic inspections according to the items listed in Table 7.3-1. Before performing periodic inspection 1, shut down the power and then remove the front cover.

Even if the power has been shut down, it takes the time for the DC link bus capacitor to discharge. After the charging lamp is turned OFF, therefore, make sure that the DC link bus voltage has dropped to the safe level (+25 VDC or below) using a multimeter or a similar instrument.

Table 7.3-1 Periodic Inspection List 1

Check part		Check item	How to inspect	Evaluation criteria
Structure such as frame and cover		Check for: 1) Loose bolts (at clamp sections). 2) Deformation and breakage 3) Discoloration caused by overheat 4) Contamination and accumulation of dust or dirt	1) Retighten. 2), 3), 4) Visual inspection	1), 2), 3), 4) No abnormalities (If any section is stained, clean it with a soft cloth.)
Main circuit	Common	1) Check that bolts and screws are tight and not missing. 2) Check the devices and insulators for deformation, cracks, breakage and discoloration caused by overheat or deterioration. 3) Check for contamination or accumulation of dust or dirt.	1) Retighten. 2), 3) Visual inspection	1), 2), 3) No abnormalities (If any section is stained, clean it with a soft cloth.)
	Conductors and wires	1) Check conductors for discoloration and distortion caused by overheat. 2) Check the sheath of the wires for cracks and discoloration.	1), 2) Visual inspection	1), 2) No abnormalities
	Terminal blocks	Check that the terminal blocks are not damaged.	Visual inspection	No abnormalities
	DC link bus capacitor	1) Check for electrolyte leakage, discoloration, cracks and swelling of the casing. 2) Check that the safety valve does not protrude remarkably.	1), 2) Visual inspection	1), 2) No abnormalities
	Braking resistor	1) Check for abnormal odor or cracks in insulators caused by overheat. 2) Check for wire breakage.	1) Olfactory and visual inspection 2) Check the wires visually, or disconnect either one of the wires and measure the conductivity with a multimeter.	1) No abnormalities 2) Within $\pm 10\%$ of the resistance of the braking resistor
Control circuit	Printed circuit board	1) Check for loose screws and connectors. 2) Check for odor and discoloration. 3) Check for cracks, breakage, deformation and remarkable rust. 4) Check the capacitors for electrolyte leaks and deformation.	1) Retighten. 2) Olfactory and visual inspection 3), 4) Visual inspection * Judgment on service life using "Menu #5 Maintenance Information" in the FRENIC-Ace User's Manual, Chapter 3, Section 3.4.5.	1), 2), 3), 4) No abnormalities
Cooling system	Cooling fan	1) Check for engagement or abnormal vibration. 2) Check for loose bolts. 3) Check for discoloration caused by overheat.	1) Turn by hand. (Be sure to turn the power OFF beforehand.) 2) Retighten. 3) Visual inspection * Judgment on service life using "Menu #5 Maintenance Information" in the FRENIC-Ace User's Manual, Chapter 3, Section 3.4.5.	1) Smooth rotation 2), 3) No abnormalities
	Ventilation path	Check the heat sink, intake and exhaust ports for clogging and foreign materials.	Visual inspection	No clogging or accumulation of dust, dirt or foreign materials. Clean it, if any, with a vacuum cleaner.

7.3.2 Periodic inspection 2--When the inverter is ON or it is running

Visually inspect the inverter for operation errors from the outside without removing the covers when the inverter is ON or it is running.

Perform periodic inspections according to the items listed in Table 7.3-2

Table 7.3-2 Periodic Inspection List 2

Check part	Check item	How to inspect	Evaluation criteria
Input voltage	Check that the input voltages of the main and control circuits are correct.	Measure the input voltages using a multimeter or the like.	The standard specifications must be satisfied.
Structure such as chassis and covers	Check for abnormal noise or excessive vibration when the inverter is running.	Visual and auditory inspections	No abnormalities
Main circuit	Transformers and reactors	Check for abnormal roaring noise or odor when the inverter is running.	Auditory, visual, and olfactory inspections
	Magnetic contactors and relays	Check for chatters when the inverter is running.	Auditory inspection
	DC link bus capacitor	Measure the capacitance if necessary.	Judgment on service life using "Menu #5 Maintenance Information (S.L.H.E)" in the FRENIC-Ace User's Manual, Chapter 3, Section 3.4.5.
Cooling fans	Check for abnormal noise or excessive vibration when the inverter is running.	Visual and auditory inspections	No abnormalities

Additional notes

- (1) The inspection interval (every year) of check items given in Table 7.3-1 and Table 7.3-2 is merely a guide. Make the interval shorter depending on the usage environment.
- (2) Store and organize the inspection results to utilize them as a guide for operation and maintenance of the equipment and service life estimation.
- (3) At the time of an inspection, check the cumulative run times on the keypad to utilize them as a guide for replacement of parts. Refer to "7.4.1 Judgment on service life".
- (4) The inverter has cooling fans inside to ventilate itself for discharging the heat generated by the power converter section. This will accumulate dust or dirt on the heat sink depending on the ambient environment. In a dusty environment, the heat sink requires cleaning in a shorter interval than that specified in periodic inspection. Neglecting cleaning of the heat sink can rise its temperature, activating protective circuits to lead to an abrupt shutdown or causing the temperature rise of the surrounding electronic devices to adversely affect their service life.

7.4 List of Periodic Replacement Parts

Each part of the inverter has its own service life that will vary according to the environmental and operating conditions. It is recommended that the following parts be replaced at the specified intervals.

When the replacement is necessary, consult your Fuji Electric representative.

Table 7.4-1 Replacement Parts

Part name	Standard replacement intervals (See Note below.)
DC link bus capacitor	10 years (7 years in the ND mode)
Electrolytic capacitors on printed circuit boards	10 years (7 years in the ND mode)
Cooling fans	10 years (7 years in the ND mode)
Fuses	10 years (7 years in the ND mode)

Note. These replacement intervals are based on the inverter's service life estimated at a surrounding temperature of 40°C at 100% (HHD-mode inverters) or 80% (ND-/HD-/HND-mode inverters) of full load. In environments with an ambient temperature above 40°C or a large amount of dust or dirt, the replacement intervals may be shorter. The condition for inverters of FRN0020E2-2□/FRN0012E2-4□/FRN0011E2-7□ or below capacity models is a load ratio of 80% even for HHD-mode.

Notes for periodic replacement of parts

- (1) The replacement intervals listed above are a guide for almost preventing parts from failure if those parts are replaced with new ones at the intervals. They do not guarantee the completely fault-free operation.
- (2) Table 7.4-1 does not apply to unused spare parts being kept in storage.
It applies only when they are stored under the temporary and long-term storage conditions given in Chapter 1 "1.3.2 Storage environment" and energized approximately once a year.
- (3) Cooling fans can be replaced by users. As for other parts, only the persons who have finished the Fuji Electric training course can replace them. For the purchase of spare cooling fans and the request for replacement of other parts, contact the sales agent where you purchased the product or your nearest Fuji Electric representative.

7.4.1 Judgment on service life

The inverter has the life prediction function for some parts which measures the discharging time or counts the voltage applied time, etc. The function allows you to monitor the current lifetime state on the LED monitor and judge whether those parts are approaching the end of their service life.

The life prediction function can also issue early warning signals if the life time alarm command **LIFE** is assigned to any of the digital output terminals. Refer to the FRENIC-Ace User's Manual, Chapter 3 "3.4.5 Reading maintenance information "Maintenance Information: *S.L.H.E*".

Table 7.4-2 lists the parts whose service life can be predicted and details the life prediction function. The predicted values should be used only as a guide since the actual service life is influenced by the ambient temperature and other usage environments.

Table 7.4-2 Life Prediction

Object of life prediction	Prediction function	End-of-life criteria	Prediction timing	"5: MAINTENANCE" on the LED monitor
DC link bus capacitor	<u>Measurement of discharging time</u> Measures the discharging time of the DC link bus capacitor when the main power is shut down and calculates the capacitance.	85% or lower of the initial capacitance at shipment	At periodic inspection (H98: Bit 3 = 0)	<i>5_05</i> (Capacity)
		85% or lower of the reference capacitance under ordinary operating conditions at the user site	During ordinary operation (H98: Bit 3 = 1)	<i>5_05</i> (Capacity)
	<u>ON-time counting</u> Counts the time elapsed when the voltage is applied to the DC link bus capacitor, while correcting it according to the capacitance measured above.	Exceeding 87,600 hours (10 years)	During ordinary operation	<i>5_26</i> (Elapsed time) <i>5_27</i> (Time remaining before the end of life)
Electrolytic capacitors on printed circuit boards	Counts the time elapsed when the voltage is applied to the capacitors, while correcting it according to the surrounding temperature.	Exceeding 87,600 hours (10 years)	During ordinary operation	<i>5_06</i> (Cumulative run time)
Cooling fans	Counts the run time of the cooling fans.	Exceeding 87,600 hours (10 years)	During ordinary operation	<i>5_07</i> (Cumulative run time)

The service life of the DC link bus capacitor can be judged by the "Measurement of discharging time of the DC link bus capacitor" or "ON-time counting of DC link bus capacitor."

Measurement of discharging time of the DC link bus capacitor

- The discharging time of the DC link bus capacitor depends largely on the inverter's internal load conditions, e.g. options attached or ON/OFF status of digital I/O signals. If actual load conditions are so different from the ones at which the initial/reference capacitance is measured that the measurement result falls out of the accuracy level required, then the inverter does not measure.
When the inverter is connected with a converter or with another inverter via DC common connection, it does not perform any measurement.
- The capacitance measuring conditions at shipment are drastically restricted, e.g., all input terminals being OFF in order to stabilize the load and measure the capacitance accurately. Those conditions are, therefore, different from the actual operating conditions in almost all cases. If the actual operating conditions are the same as those at shipment, shutting down the inverter power automatically measures the discharging time; however, if they are different, no automatic measurement is performed. To perform it, put those conditions back to the factory default ones and shut down the inverter. Refer to 7.4.1 [1] Measuring the capacitance of DC link bus capacitor in comparison with initial one at shipment on page 7-6.
- To measure the capacitance of the DC link bus capacitor *under ordinary operating conditions* when the power is turned OFF, it is necessary to set up the load conditions for ordinary operation and measure the reference capacitance (initial setting) when the inverter is introduced. For the reference capacitance setup procedure, see [2] on page 7-7 Performing the setup procedure automatically detects and saves the measuring conditions of the DC link bus capacitor.

Setting bit 3 of H98 data at "0" restores the inverter to the measurement in comparison with the initial capacitance measured at shipment.

Note When the inverter uses an auxiliary control power input, the load conditions widely differ so that the discharging time cannot be accurately measured. In this case, measuring of the discharging time can be disabled with the function code H98 (Bit 4 = 0) for preventing unintended measuring.

ON-time counting of DC link bus capacitor

- In a machine system where the inverter main power is rarely shut down, the inverter does not measure the discharging time. For this case, the ON-time counting is provided. The ON-time counting result can be represented as "elapsed time" ($S_{-}Z5$) and "time remaining before the end of life" ($S_{-}Z7$) as shown in the "DC link bus capacitor" section in Table 7.4-2.

[1] Measuring the capacitance of DC link bus capacitor in comparison with initial one at shipment

The measuring procedure given below measures the capacitance of DC link bus capacitor in comparison with initial one at shipment when the power is turned OFF. The measuring result can be displayed on the keypad as a ratio (%) to the initial capacitance.

----- **Capacitance measuring procedure** -----

- 1) To ensure validity in the comparative measurement, put the condition of the inverter back to the state at factory shipment.
 - Remove the option card (if already in use) from the inverter.
 - In case another inverter is connected via the DC link bus to the P(+) and N(-) terminals of the main circuit, disconnect the wires. It is not required to disconnect the DC reactor (optional), if any.
 - Disconnect power wires for the auxiliary input to the control circuit (R0, T0).
 - Mount the keypad.
 - Turn OFF all the digital input signals fed to terminals [FWD], [REV], and [X1] through [X5] of the control circuit.
 - If an external speed command potentiometer is connected to terminal [13], disconnect it.
 - If an external apparatus is attached to terminal [PLC], disconnect it.
 - Ensure that transistor outputs [Y1] and [Y2] and Relay output terminals [30A/B/C] will not be turned ON.
 - Disable the RS-485 communications link and CANopen communications link.

Note If negative logic is specified for the transistor output and relay output signals, they are considered ON when the inverter is not running. Specify positive logic for them.

- 2) Turn ON the main circuit power.
- 3) Confirm that the DC cooling fan is rotating and the inverter is in stopped state. Disable the cooling fan ON/OFF control (H06 = 0).
- 4) Shut down the main circuit power.

5) The inverter automatically starts the measurement of the capacitance of the DC link bus capacitor.

Note If “. . . .” does not appear on the LED monitor, the measurement has not started. Check the conditions listed in 1).

6) After “. . . .” has disappeared from the LED monitor, turn ON the main circuit power again.

7) Select Menu #5 “Maintenance Information” in Programming mode and check the capacitance (%) of the DC link bus capacitor (5_05).

[2] Measuring the capacitance of the DC link bus capacitor under ordinary operating conditions

The inverter automatically measures the capacitance of the DC link bus capacitor under ordinary operating conditions when the power is turned OFF. This measurement requires setting up the load conditions for ordinary operation and measuring the reference capacitance when the inverter is introduced to the practical operation, using the setup procedure given below

----- Reference capacitance setup procedure -----

- 1) Set bit 3 of function code H98 at “1” (User mode) to enable the user to specify the judgment criteria for the service life of the DC link bus capacitor.
- 2) Turn OFF all run commands.
- 3) Make the inverter ready to be turned OFF under ordinary operating conditions.
- 4) Set each of function codes H42 (Capacitance of DC link bus capacitor) and H47 (Initial capacitance of DC link bus capacitor) at “0000”.
- 5) Turn OFF the inverter, and the following operations are automatically performed.

The inverter measures the discharging time of the DC link bus capacitor and saves the result in function code H47 (Initial capacitance of DC link bus capacitor).

The conditions under which the measurement has been conducted will be automatically collected and saved.

- 6) Turn ON the inverter again.

Confirm that H47 (Initial capacitance of DC link bus capacitor) holds right values. Switch to Menu #5 “Maintenance Information” in Programming mode and confirm that the main capacitor capacity is 100% (5_05 = 100%).

Note If the measurement has failed, “0001” is entered into each of H42 and H47. Remove the cause of the failure and conduct the measurement again.

Hereafter, each time the inverter is turned OFF, it automatically measures the discharging time of the DC link bus capacitor if the above conditions are met. Periodically check the capacitance (%) of the DC link bus capacitor (5_05) with Menu #5 “Maintenance Information” in Programming mode.

Note The condition given above produces a rather large measurement error. If this mode gives you a lifetime alarm, revert bit 3 of H98 (Main circuit capacitor life judgment selection) to the default setting (Bit 3 = 0) and conduct the measurement under the condition at the time of factory shipment.

[3] Early warning of lifetime alarm

For the components listed in Table 7.4-2, the inverter can issue an early warning of lifetime alarm LIFE at one of the transistor output terminals [Y1] and [Y2] and Relay output terminals [30A/B/C] as soon as any one of the levels specified in Table 7.4-2 has been exceeded.

The early warning signal is also turned ON when a lock condition on the internal air circulation DC fan (provided on FRN0203E2■-4□ or above) has been detected.

7.5 Measurement of Electrical Amounts in Main Circuit

Because the voltage and current of the power supply (input, primary circuit) of the main circuit of the inverter and those of the motor (output, secondary circuit) contain harmonic components, the readings may vary with the type of the meter. Use meters indicated in Table 7.5-1 when measuring main circuit.

The power factor cannot be measured by a commercially available power-factor meter that measures the phase difference between the voltage and current. To obtain the power factor, measure the power, voltage and current on each of the input and output sides and use the following formula.

■ Three-phase input

$$\text{Power factor} = \frac{\text{Electric power (W)}}{\sqrt{3} \times \text{Voltage (V)} \times \text{Current (A)}} \times 100\%$$

Table 7.5-1 Meters for Measurement of Main Circuit

Item	Input (primary) side			Output (secondary) side			DC link bus voltage (P(+)-N(-))
Waveform	Voltage 		Current 	Voltage 		Current 	
Name of meter	Ammeter AR, AS, AT	Voltmeter VR, VS, VT	Wattmeter WR, WT	Ammeter AU, AV, AW	Voltmeter VU, VV, VW	Wattmeter WU, WW	DC voltmeter V
Type of meter	Moving iron type	Rectifier or moving iron type	Digital AC power meter	Digital AC power meter	Digital AC power meter	Digital AC power meter	Moving coil type
Symbol of meter			—	—	—	—	

Note It is not recommended that meters other than a digital AC power meter be used for measuring the output voltage or output current since they may cause larger measurement errors or, in the worst case, they may be damaged.

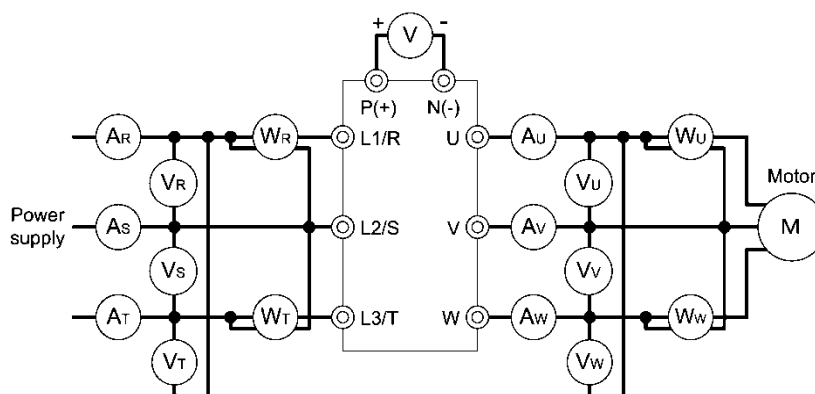

Figure 7.5-1 Connection of Meters

7.6 Insulation Test

Since the inverter has undergone an insulation test before shipment, avoid making a Megger test at the customer's site.

If a Megger test is unavoidable for the main circuit, observe the following instructions; otherwise, the inverter may be damaged.

A withstand voltage test may also damage the inverter if the test procedure is wrong. When the withstand voltage test is necessary, consult your Fuji Electric representative.

(1) Megger test of main circuit

- 1) Use a 500 VDC Megger and ensure that the main power has been shut off before measurement.
- 2) If the test voltage leaks to the control circuit due to the wiring, disconnect all the wiring from the control circuit.
- 3) Connect the main circuit terminals with a common line as shown in Figure 7.6-1.
- 4) The Megger test must be limited to across the common line of the main circuit and the ground (⊕).
- 5) Value of 5 MΩ or more displayed on the Megger indicates a correct state. (The value is measured on the inverter alone.)

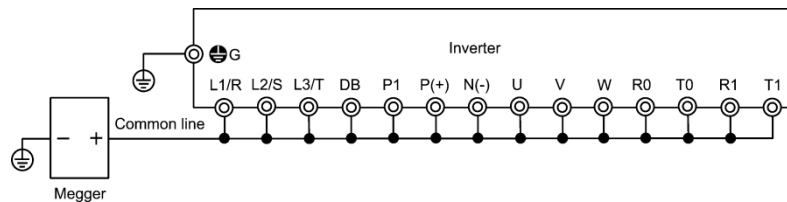

Figure 7.6-1 Main Circuit Terminal Connection for Megger Test

(2) Insulation test of control circuit

Do not make a Megger test or withstand voltage test for the control circuit. Use a high resistance range tester for the control circuit.

- 1) Disconnect all the external wiring from the control circuit terminals.
- 2) Perform a continuity test to the ground. One MΩ or a larger measurement indicates a correct state.

(3) Insulation test of external main circuit and sequence control circuit

Disconnect all the wiring connected to the inverter so that the test voltage is not applied to the inverter.

7.7 Inquiries about Product and Guarantee

7.7.1 When making an inquiry

Upon breakage of the product, uncertainties, failure or inquiries, inform your Fuji Electric representative of the following information.

- 1) Inverter type. Refer to Chapter 1 "1.1 Acceptance Inspection (Nameplates and Inverter Type)".
- 2) SER No. (serial number of equipment). Refer to Chapter 1 "1.1 Acceptance Inspection (Nameplates and Inverter Type)".
- 3) Function codes and their data that you changed. Refer to the FRENIC-Ace User's Manual, Chapter 3 "3.4.2 Checking changed function codes "Data Checking: $\overline{2rEP}$ ".
- 4) ROM version. Refer to the maintenance item $\overline{5H}$ in the FRENIC-Ace User's Manual, Chapter 3 "3.4.5 Reading maintenance information "Maintenance Information: $\overline{5LHE}$ ".
- 5) Date of purchase
- 6) Inquiries (for example, point and extent of breakage, uncertainties, failure phenomena, and other circumstances)

7.7.2 Product warranty

To all our customers who purchase Fuji Electric products included in this documentation:

Please take the following items into consideration when placing your order.

When requesting an estimate and placing your orders for the products included in these materials, please be aware that any items such as specifications which are not specifically mentioned in the contract, catalog, specifications or other materials will be as mentioned below.

In addition, the products included in these materials are limited in the use they are put to and the place where they can be used, etc., and may require periodic inspection. Please confirm these points with your sales representative or directly with this company.

Furthermore, regarding purchased products and delivered products, we request that you take adequate consideration of the necessity of rapid receiving inspections and of product management and maintenance even before receiving your products.

[1] Free of charge warranty period and warranty range

(1) Free of charge warranty period

- 1) The product warranty period is "1 year from the date of purchase" or 24 months from the manufacturing date imprinted on the name place, whichever date is earlier.
- 2) However, in cases where the use environment, conditions of use, use frequency and times used, etc., have an effect on product life, this warranty period may not apply.
- 3) Furthermore, the warranty period for parts restored by Fuji Electric's Service Department is "6 months from the date that repairs are completed."

(2) Warranty range

- 1) In the event that breakdown occurs during the product's warranty period which is the responsibility of Fuji Electric, Fuji Electric will replace or repair the part of the product that has broken down free of charge at the place where the product was purchased or where it was delivered. However, if the following cases are applicable, the terms of this warranty may not apply.
 - ① The breakdown was caused by inappropriate conditions, environment, handling or use methods, etc. which are not specified in the catalog, operation manual, specifications or other relevant documents.
 - ② The breakdown was caused by the product other than the purchased or delivered Fuji's product.
 - ③ The breakdown was caused by the product other than Fuji's product, such as the customer's equipment or software design, etc.
 - ④ Concerning the Fuji's programmable products, the breakdown was caused by a program other than a program supplied by this company, or the results from using such a program.
 - ⑤ The breakdown was caused by disassembly, modifications or repairs affected by a party other than Fuji Electric.
 - ⑥ The breakdown was caused by improper maintenance or replacement using consumables, etc. specified in the operation manual or catalog, etc.
 - ⑦ The breakdown was caused by a science or technical problem that was not foreseen when making practical application of the product at the time it was purchased or delivered.
 - ⑧ The product was not used in the manner the product was originally intended to be used.
 - ⑨ The breakdown was caused by a reason which is not this company's responsibility, such as lightning or other disaster.
- 2) Furthermore, the warranty specified herein shall be limited to the purchased or delivered product alone.
- 3) The upper limit for the warranty range shall be as specified in item (1) above and any damages (damage to or loss of machinery or equipment, or lost profits from the same, etc.) consequent to or resulting from breakdown of the purchased or delivered product shall be excluded from coverage by this warranty.

(3) Trouble diagnosis

As a rule, the customer is requested to carry out a preliminary trouble diagnosis. However, at the customer's request, this company or its service network can perform the trouble diagnosis on a chargeable basis. In this case, the customer is asked to assume the burden for charges levied in accordance with this company's fee schedule.

[2] Exclusion of liability for loss of opportunity, etc.

Regardless of whether a breakdown occurs during or after the free of charge warranty period, this company shall not be liable for any loss of opportunity, loss of profits, or damages arising from special circumstances, secondary damages, accident compensation to another company, or damages to products other than this company's products, whether foreseen or not by this company, which this company is not be responsible for causing.

[3] Repair period after production stop, spare parts supply period (holding period)

Concerning models (products) which have gone out of production, this company will perform repairs for a period of 7 years after production stop, counting from the month and year when the production stop occurs. In addition, we will continue to supply the spare parts required for repairs for a period of 7 years, counting from the month and year when the production stop occurs. However, if it is estimated that the life cycle of certain electronic and other parts is short and it will be difficult to procure or produce those parts, there may be cases where it is difficult to provide repairs or supply spare parts even within this 7-year period. For details, please confirm at our company's business office or our service office.

[4] Transfer rights

In the case of standard products which do not include settings or adjustments in an application program, the products shall be transported to and transferred to the customer and this company shall not be responsible for local adjustments or trial operation.

[5] Service contents

The cost of purchased and delivered products does not include the cost of dispatching engineers or service costs. Depending on the request, these can be discussed separately.

[6] Applicable scope of service

Above contents shall be assumed to apply to transactions and use of the country where you purchased the products.

Consult the local supplier or Fuji for details separately.

APPENDICES

Appendix G Conformity with Standards

G.1 Compliance with European Standards (CE)

The CE marking on Fuji products indicates that they comply with the essential requirements of the Electromagnetic Compatibility (EMC) Directive 2004/108/EC, Low Voltage Directive 2006/95/EC, and Machinery Directive 2006/42/EC which are issued by the Council of the European Communities.

Table G-1 Conformity with Standards

	Standards
EMC Directives	IEC/EN61800-3 : 2004/A1 : 2012 Immunity : Second environment (Industrial) Emission : Category C2 (Applicable only when an optional EMC-compliant filter is attached) : Type of FRN0012E2E-4□ or below : Category C2 Type of FRN0011E2E-7□ or below : Category C2 Type of FRN0020E2E-4□ or above : Category C3 (Applicable only to the EMC filter built-in type of inverters) IEC/EN61326-3-1 : 2008
Low Voltage Directive	IEC/EN61800-5-1 : 2007

CAUTION

The EMC filter built-in type of the FRENIC-Ace inverters is categorized as "Category C3" of the EN61800-3. It is not designed for use in a domestic environment. It may interfere with the operations of home appliances or office equipment due to noise emitted from it.

[1] Compliance with EMC standards

The CE marking on inverters does not ensure that the entire equipment including our CE-marked products is compliant with the EMC Directive. Therefore, CE marking for the equipment shall be the responsibility of the equipment manufacturer. For this reason, Fuji's CE mark is indicated under the condition that the product shall be used within equipment meeting all requirements for the relevant Directives. Instrumentation of such equipment shall be the responsibility of the equipment manufacturer.

Generally, machinery or equipment includes not only our products but other devices as well. Manufacturers, therefore, shall design the whole system to be compliant with the relevant Directives.

■ List of EMC-compliant filters

To satisfy the requirements noted above, use the EMC filter built-in type inverters or the combination of the basic type of inverters that have no built-in EMC filter and an external filter (option) dedicated to Fuji inverters. In either case, mount inverters in accordance with the installation procedure given below. To ensure the compliance, it is recommended to mount the inverters in a metal panel.

 **Tip** Our EMC compliance test is performed under the following conditions.
Wiring length (of the shielded cable) between the inverter (EMC filter built-in type) and motor: 10m

 **Note** To use Fuji inverters in combination with a PWM converter, the basic type of inverters having no built-in EMC filter should be used. Use of an EMC filter built-in type may increase heat of capacitors in the inverter, resulting in damage. In addition, the effect of the EMC filter can no longer be expected.

Table G-2 EMC-compliant filter

Power supply voltage	Inverter type	Specification	Filter type
Three-phase 400V	FRN0002E2■-4□	ND/HD/HND/HHD	W62400-T1688-E002 *1)
	FRN0004E2■-4□	ND/HD/HND/HHD	W62400-T1688-E002 *1)
	FRN0006E2■-4□	ND/HD/HND/HHD	W62400-T1688-E002 *1)
	FRN0007E2■-4□	ND/HD/HHD	W62400-T1688-F002 *1)
	FRN0012E2■-4□	ND/HD/HHD	W62400-T1688-F002 *1)
	FRN0022E2■-4□	ND	FS21312-44-07
		HD/HND	FS21559-24-07-01
		HHD	FS21559-24-07-01
	FRN0029E2■-4□	ND	FS21312-44-07
		HD/HND	FS21312-44-07
		HHD	FS21559-24-07-01
	FRN0037E2■-4□	ND	FS5536-72-07 (EFL-22G11-4)
		HD/HND	FS21312-44-07
		HHD	FS21312-44-07
	FRN0044E2■-4□	ND	FS5536-72-07 (EFL-22G11-4)
		HD/HND	FS5536-72-07 (EFL-22G11-4)
		HHD	FS21312-44-07
	FRN0059E2■-4□	ND	FS21312-78-07
		HD/HND	FS5536-72-07 (EFL-22G11-4)
		HHD	FS5536-72-07 (EFL-22G11-4)
	FRN0072E2■-4□	ND	-
		HD/HND	FS21312-78-07
		HHD	FS5536-72-07 (EFL-22G11-4)
	FRN0085E2■-4□	ND	FS5536-180-40
		HD/HND	FS5536-100-35
		HHD	FS5536-100-35
	FRN0105E2■-4□	ND	FS5536-180-40
		HD/HND	FS5536-180-40
		HHD	FS5536-100-35
	FRN0139E2■-4□	ND/HD/HND/HHD	FS5536-180-40
	FRN0168E2■-4□	ND/HD/HND/HHD	FS5536-180-40
	FRN0203E2■-4□	ND	FS5536-250-99-1
		HD/HND/HHD	FS5536-180-40
	FRN0240E2■-4□	ND	FS5536-250-99-1
		HD/HND	FS5536-250-99-1
		HHD	FS5536-180-40
	FRN0290E2■-4□	ND	FS5536-400-99-1
		HD/HND	FS5536-250-99-1
		HHD	FS5536-250-99-1
	FRN0361E2■-4□	ND	FS5536-400-99-1
HD/HND		FS5536-400-99-1	
HHD		FS5536-250-99-1	
FRN0415E2■-4□	ND/HD/HND/HHD	FS5536-400-99-1	
FRN0520E2■-4□	ND/HD/HND/HHD	FS5536-400-99-1	
FRN0590E2■-4□	ND	FN3359-600-99 *2)	
	HD/HND	FN3359-600-99 *2)	
	HHD	FS5536-400-99-1	

*1) A ferrite core is added for input power wires and grounding wire (2 turns), or two ferrite cores are added for input power wires and grounding wire, 1 turns.

*2) IF carrier frequency setting is 4 kHz or less or a zero-phase reactor is added at the input cable, conforms category C2. Except this condition, conforms category C3.

Note: A box (■) in the above table replaces S (Basic type) or E (EMC filter built-in type) depending on the enclosure. A box (□) in the above table replaces GA, GB, A, E, U, K or C depending on the model.

Power supply voltage	Inverter type	Specification	Filter type
Three-phase 200V	FRN0001E2■-2□	HND/HHD	W62400-T1688-E002
	FRN0002E2■-2□	HND/HHD	W62400-T1688-E002
	FRN0004E2■-2□	HND/HHD	W62400-T1688-E002
	FRN0006E2■-2□	HND/HHD	W62400-T1688-E002
	FRN0010E2■-2□	HND/HHD	W62400-T1688-H005 *3)
	FRN0012E2■-2□	ND/HHD	W62400-T1688-H005 *3)
	FRN0020E2■-2□	ND/HHD	W62400-T1688-H005 *3)
	FRN0030E2■-2□	HND	FS5956-53-52
		HHD	FS5956-53-52
	FRN0040E2■-2□	HND	EFL-15SP-2
		HHD	FS5956-53-52
	FRN0056E2■-2□	HND	EFL-15SP-2
		HHD	EFL-15SP-2
	FRN0069E2■-2□	HND	EFL-15SP-2
		HHD	EFL-15SP-2
	FRN0088E2■-2□	HND	EFL-22SP-2
		HHD	EFL-22SP-2
FRN0115E2■-2□	HND	FS5536-180-40	
	HHD	EFL-22SP-2	
Single-phase 200V	FRN0001E2■-7□	HHD	W62400-T1775-E001
	FRN0002E2■-7□	HHD	W62400-T1775-E001
	FRN0003E2■-7□	HHD	W62400-T1775-E001
	FRN0005E2■-7□	HHD	W62400-T1775-E001
	FRN0008E2■-7□	HHD	W62400-T1775-F001
	FRN0011E2■-7□	HHD	W62400-T1775-F001

*3) A ferrite core is added for input power wires and grounding wire (1 turn).

Note: A box (■) in the above table replaces S (Basic type) or E (EMC filter built-in type) depending on the enclosure.

A box (□) in the above table replaces GA, GB, A, E, U, K or C depending on the model.

■ Recommended installation procedure

To make the machinery or equipment fully compliant with the EMC Directive, certified technicians should wire the motor and inverter in strict accordance with the procedure described below.

In case an external EMC-compliant filter (option) is used

- (1) Mount the inverter and the filter on a grounded panel or metal plate. Use shielded wires for the motor cable and route the cable as short as possible. Firmly clamp the shields to the metal plate to ground them. Further, connect the shielding layers electrically to the grounding terminal of the motor.
- (2) For connection to inverter's control terminals and for connection of the RS-485 communication signal cable, use shielded wires. As with the motor connections, clamp the shields firmly to a grounded panel.
- (3) If noise from the inverter exceeds the permissible level, enclose the inverter and its peripherals within a metal panel as shown in Figure G-1.

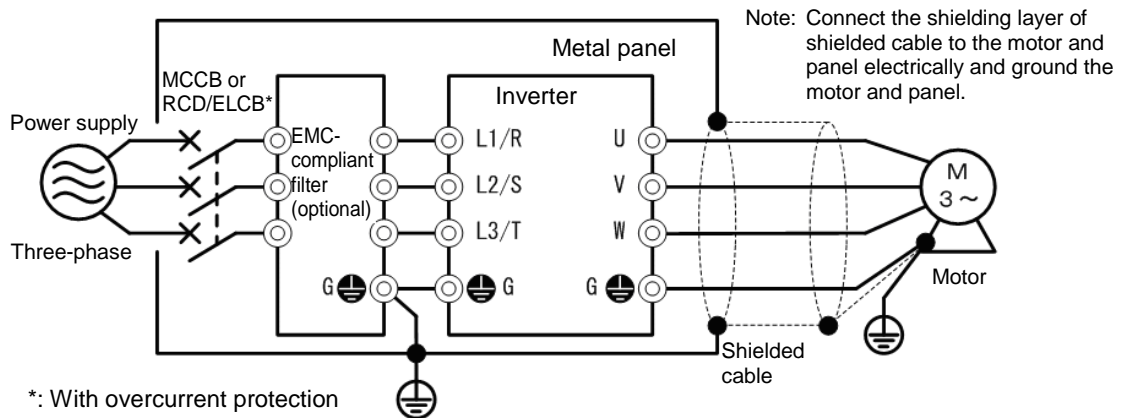

Figure G-1 Mounting an EMC-compliant Filter (option) in a Metal Panel

In case of EMC filter built-in type inverter

- (1) Mount the inverter and the filter on a grounded panel or metal plate. Use shielded wires for the motor cable and route the cable as short as possible. Firmly clamp the shields to the metal plate to ground them. Further, connect the shielding layers electrically to the grounding terminal of the motor.
- (2) For connection to inverter's control terminals and for connection of the RS-485 communication signal cable, use shielded wires. As with the motor connections, clamp the shields firmly to a grounded panel.
- (3) If noise from the inverter exceeds the permissible level, enclose the inverter and its peripherals within a metal panel as shown in Figure G-2.

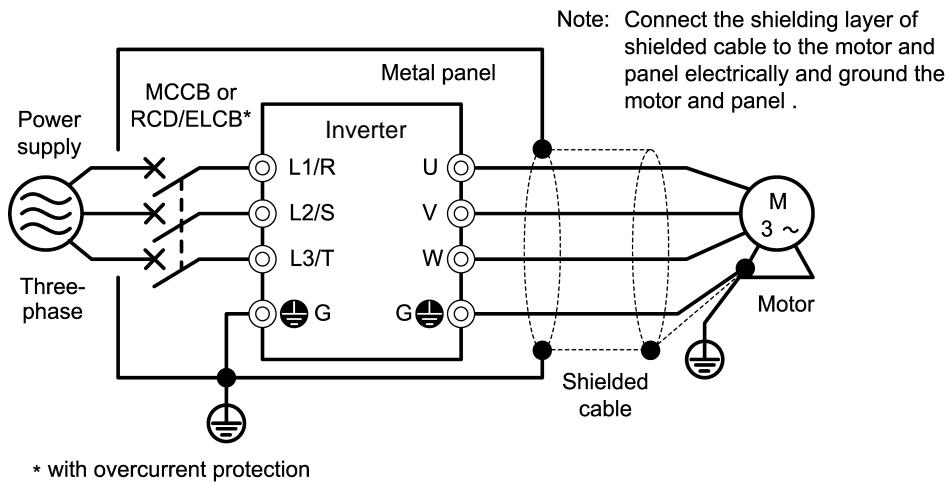

Figure G-2 Mounting the inverter in a Metal Panel

■ Leakage current of EMC-filter built-in type of inverters

An EMC filter uses grounding capacitors for noise suppression which increase leakage current. When using an EMC-filter built-in type of inverters, therefore, check whether there is no problem with electrical systems.

⚠ CAUTION

Three-Phase PDS (Power Drive System) with touch currents ≥ 3.5 mA AC or ≥ 10 mA DC

As the touch current (leakage current) of inverters with EMC-filter is relatively high, it is of essential importance to always assure a reliable connection to Protective Earth (PE).

In Table G-3, for the inverter types whose leakage currents are equal to or exceed the critical value of 3.5 mA AC or 10 mA DC (IEC 61800-5-1), the minimum cross sectional area of the PE-conductor should be:

- 10 mm² (Cu-conductors)
- 16 mm² (Al-conductors)

An electric shock could occur.

Table G-3 Leakage Current of EMC Filter Built-in Type of Inverters

Power supply voltage	Inverter type	Leakage current (mA)
Three-phase 400V *1)	FRN0002E2E-4□	*1
	FRN0004E2E-4□	*1
	FRN0006E2E-4□	*1
	FRN0007E2E-4□	*1
	FRN0012E2E-4□	*1
	FRN0022E2E-4□	*1
	FRN0029E2E-4□	*1
	FRN0037E2E-4□	*1
	FRN0044E2E-4□	*1
	FRN0059E2E-4□	4
	FRN0072E2E-4□	
	FRN0085E2E-4□	11
	FRN0105E2E-4□	
	FRN0139E2E-4□	
	FRN0168E2E-4□	5
	FRN0203E2E-4□	
	FRN0290E2E-4□	
	FRN0361E2E-4□	
	FRN0415E2E-4□	
	FRN0520E2E-4□	
FRN0590E2E-4□		
Single-phase 200V *2)	FRN0001E2E-7□	*1
	FRN0002E2E-7□	*1
	FRN0004E2E-7□	*1
	FRN0006E2E-7□	*1
	FRN0010E2E-7□	*1
	FRN0012E2E-7□	*1

*1) Calculated based on these measuring conditions: 480 V/ 60 Hz, neutral grounding in Y-connection, interphase voltage unbalance ratio 2%.

*2) Calculated based on these measuring conditions: 240 V/ 60 Hz, one-phase grounding in delta-connection, interphase voltage unbalance ratio 2%.

Note: A box (□) in the above table replaces GA, GB, A, E, U, K or C depending on the model.

*1 Please contact Fuji Electric about these models.

[2] Compliance with the low voltage directive in the EU

General-purpose inverters are regulated by the Low Voltage Directive in the EU. Fuji Electric states that all our inverters with CE marking are compliant with the Low Voltage Directive.



■ Note

If installed according to the guidelines given below, inverters marked with CE are considered as compliant with the Low Voltage Directive 2006/95/EC.

Compliance with European Standards

Adjustable speed electrical power drive systems.

Part 5-1: Safety requirements. Electrical, thermal and energy. IEC/EN61800-5-1 : 2007

  WARNING				
<p>1. The ground terminal  G should always be connected to the ground. Do not use only a residual-current-operated protective device (RCD)/earth leakage circuit breaker (ELCB)* as the sole method of electric shock protection. Be sure to use ground wires whose size is greater than power supply lines. *With overcurrent protection.</p> <p>2. To prevent the risk of hazardous accidents that could be caused by damage of the inverter, install the specified fuses in the supply side (primary side) according to the following tables.</p> <p>• Breaking capacity: Min. 10 kA • Rated voltage: Min. 500 V</p>				
Power supply voltage	Nominal applied motor (kW)	Inverter type	HHD/HND/HD/ND mode	Fuse rating (A)
Three phase 200V	0.1	FRN0001E2■-2□	HHD	6(IEC60269-2)
	0.2		HND	6(IEC60269-2)
	0.2	FRN0002E2■-2□	HHD	6(IEC60269-2)
	0.4		HND	6(IEC60269-2)
	0.4	FRN0004E2■-2□	HHD	10(IEC60269-2)
	0.75		HND	10(IEC60269-2)
	0.75	FRN0006E2■-2□	HHD	15(IEC60269-2)
	1.5		HND	15(IEC60269-2)
	1.5	FRN0010E2■-2□	HHD	20(IEC60269-2)
	2.2		HND	20(IEC60269-2)
	2.2	FRN0012E2■-2□	HHD	30(IEC60269-2)
	3.0		ND	30(IEC60269-2)
	3.7	FRN0020E2■-2□	HHD	40(IEC60269-2)
	5.5		ND	50(IEC60269-2)
	5.5	FRN0030E2■-2□	HHD	125(IEC60269-4)
	7.5		HND	125(IEC60269-4)
	7.5	FRN0040E2■-2□	HHD	160(IEC60269-4)
	11		HND	160(IEC60269-4)
	11	FRN0056E2■-2□	HHD	160(IEC60269-4)
	15		HND	160(IEC60269-4)
15	FRN0069E2■-2□	HHD	200(IEC60269-4)	
18.5		HND	200(IEC60269-4)	
18.5	FRN0088E2■-2□	HHD	250(IEC60269-4)	
22		HND	250(IEC60269-4)	
22	FRN0115E2■-2□	HHD	350(IEC60269-4)	
30		HND	350(IEC60269-4)	

  **WARNING**

Power supply voltage	Nominal applied motor (kW)	Inverter type	HHD/HND/HD/ND mode	Fuse rating (A)
Three phase 400V	0.4	FRN0002E2■-4□	HHD	3(IEC60269-2)
	0.75		HND/HD	6(IEC60269-2)
	0.75		ND	6(IEC60269-2)
	0.75	FRN0004E2■-4□	HHD	6(IEC60269-2)
	1.1		HND/HD	10(IEC60269-2)
	1.5		ND	10(IEC60269-2)
	1.5	FRN0006E2■-4□	HHD	10(IEC60269-2)
	2.2		HND/HD	15(IEC60269-2)
	2.2		ND	15(IEC60269-2)
	2.2	FRN0007E2■-4□	HHD	15(IEC60269-2)
	3.0		HD	20(IEC60269-2)
	3.0		ND	20(IEC60269-2)
	3.7	FRN0012E2■-4□	HHD	20(IEC60269-2)
	5.5		HD	30(IEC60269-2)
	5.5		ND	30(IEC60269-2)
	5.5	FRN0022E2■-4□	HHD	80(IEC60269-4)
	7.5		HND/HD	80(IEC60269-4)
	11		ND	80(IEC60269-4)
	7.5	FRN0029E2■-4□	HHD	80(IEC60269-4)
	11		HND/HD	80(IEC60269-4)
	15		ND	125(IEC60269-4)
	11	FRN0037E2■-4□	HHD	125(IEC60269-4)
	15		HND/HD	125(IEC60269-4)
	18.5		ND	125(IEC60269-4)
	18.5	FRN0044E2■-4□	HHD	160(IEC60269-4)
	22		HND/HD	160(IEC60269-4)
	22		ND	160(IEC60269-4)
	18.5	FRN0059E2■-4□	HHD	160(IEC60269-4)
	22		HND/HD	160(IEC60269-4)
	30		ND	160(IEC60269-4)
	22	FRN0072E2■-4□	HHD	160(IEC60269-4)
	30		HND/HD	160(IEC60269-4)
	37		ND	160(IEC60269-4)
	30	FRN0085E2■-4□	HHD	250(IEC60269-4)
	37		HND/HD	250(IEC60269-4)
	45		ND	250(IEC60269-4)
	37	FRN0105E2■-4□	HHD	315(IEC60269-4)
	45		HND/HD	315(IEC60269-4)
	55		ND	315(IEC60269-4)
	45	FRN0139E2■-4□	HHD	315(IEC60269-4)
	55		HND/HD	315(IEC60269-4)
	75		ND	315(IEC60269-4)
	55	FRN0168E2■-4□	HHD	350(IEC60269-4)
	75		HND/HD	350(IEC60269-4)
	90		ND	350(IEC60269-4)
	75	FRN0203E2■-4□	HHD	350(IEC60269-4)
	90		HND/HD	350(IEC60269-4)
	110		ND	350(IEC60269-4)
	90	FRN0240E2■-4□	HHD	350(IEC60269-4)
	110		HND/HD	350(IEC60269-4)
132	ND		450(IEC60269-4)	
110	FRN0290E2■-4□	HHD	400(IEC60269-4)	
132		HND/HD	400(IEC60269-4)	
160		ND	500(IEC60269-4)	
132	FRN0361E2■-4□	HHD	450(IEC60269-4)	
160		HND/HD	450(IEC60269-4)	
200		ND	550(IEC60269-4)	
160	FRN0415E2■-4□	HHD	500(IEC60269-4)	
200		HND/HD	500(IEC60269-4)	
220		ND	630(IEC60269-4)	
200	FRN0520E2■-4□	HHD	550(IEC60269-4)	
220		HND/HD	550(IEC60269-4)	
280		ND	900(IEC60269-4)	
220	FRN0590E2■-4□	HHD	630(IEC60269-4)	
280		HND	630(IEC60269-4)	
250		HD	630(IEC60269-4)	
315		ND	900(IEC60269-4)	

Note: A box (■) in the above table replaces S (Basic type) or E (EMC filter built-in type) depending on the enclosure.

A box (□) in the above table replaces GA, GB, A, E, U, K or C depending on the model.

⚠ ⚠ WARNING

Power supply voltage	Nominal applied motor (kW)	Inverter type	HHD/HND/HD/ND mode	Fuse rating (A)
Three phase 400V	90	FRN0240E2■-4□	HHD	350(IEC60269-4)
	110		HND/HD	350(IEC60269-4)
	132		ND	450(IEC60269-4)
	110	FRN0290E2■-4□	HHD	400(IEC60269-4)
	132		HND/HD	400(IEC60269-4)
	160		ND	500(IEC60269-4)
	132	FRN0361E2■-4□	HHD	450(IEC60269-4)
	160		HND/HD	450(IEC60269-4)
	200		ND	550(IEC60269-4)
	160	FRN0415E2■-4□	HHD	500(IEC60269-4)
	200		HND/HD	500(IEC60269-4)
	220		ND	630(IEC60269-4)
	200	FRN0520E2■-4□	HHD	550(IEC60269-4)
	220		HND/HD	550(IEC60269-4)
	280		ND	900(IEC60269-4)
	220	FRN0590E2■-4□	HHD	630(IEC60269-4)
	280		HND	630(IEC60269-4)
	250		HD	630(IEC60269-4)
315	ND		900(IEC60269-4)	
Single phase 200V	0.1	FRN0001E2■-7□	HHD	6(IEC60269-2)
	0.2	FRN0002E2■-7□	HHD	6(IEC60269-2)
	0.4	FRN0003E2■-7□	HHD	10(IEC60269-2)
	0.75	FRN0005E2■-7□	HHD	20(IEC60269-2)
	1.5	FRN0008E2■-7□	HHD	30(IEC60269-2)
	2.2	FRN0011E2■-7□	HHD	50(IEC60269-2)

Note: A box (■) in the above table replaces S (Basic type) or E (EMC filter built-in type) depending on the enclosure.

A box (□) in the above table replaces GA, GB, A, E, U, K or C depending on the model.

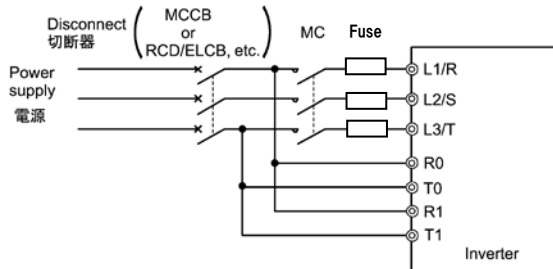

Compliance with the low voltage directive in the EU (Continued)



3. When used with the inverter, a molded case circuit breaker (MCCB), residual-current-operated protective device (RCD)/earth leakage circuit breaker (ELCB) or magnetic contactor (MC) should conform to the EN or IEC standards.
4. When you use a residual-current-operated protective device (RCD)/earth leakage circuit breaker (ELCB) for protection from electric shock in direct or indirect contact power lines or nodes, be sure to install type B of RCD/ELCB on the input (primary) of the inverter.

Power supply voltage	Nominal applied motor (kW)	Inverter type	ND/HD/HND mode	MCCB or RCD/ELCB *1 Rated current	
				W/DCR	W/o DCR
Three-phase 200 V	0.1	FRN0001E2■-2□	HHD	5	5
	0.2		HND	5	5
	0.2	FRN0002E2■-2□	HHD	5	5
	0.4		HND	5	5
	0.4	FRN0004E2■-2□	HHD	5	5
	0.75		HND	5	10
	0.75	FRN0006E2■-2□	HHD	5	10
	1.1		HND	10	10
	1.5	FRN0010E2■-2□	HHD	10	15
	2.2		HND	10	20
	2.2	FRN0012E2■-2□	HHD	10	20
	3.0		ND	20	30
	3.7	FRN0020E2■-2□	HHD	20	30
	5.5		ND	30	40
	5.5	FRN0030E2■-2□	HHD	30	50
	7.5		HND	40	75
	7.5	FRN0040E2■-2□	HHD	40	75
	11		HND	50	100
	11	FRN0056E2■-2□	HHD	50	100
	15		HND	75	125
	15	FRN0069E2■-2□	HHD	75	125
	18.5		HND	100	150
	18.5	FRN0088E2■-2□	HHD	100	150
	22		HND	100	175
22	FRN0115E2■-2□	HHD	100	175	
30		HND	150	200	
Three-phase 400 V	0.4	FRN0002E2■-4□	HHD	5	5
	0.75		HND	5	5
	0.75		HD	5	5
	0.75		ND	5	5
	1.5	FRN0004E2■-4□	HHD	5	5
	1.1		HND	5	5
	1.1		HD	5	5
	0.75		ND	5	5
	1.5	FRN0006E2■-4□	HHD	5	10
	2.2		HND	5	10
	2.2		HD	5	10
	2.2		ND	5	10
	2.2	FRN0007E2■-4□	HHD	10	15
	-		-	-	-
	3.0		HD	10	15
	3.0		ND	10	15
	3.7	FRN0012E2■-4□	HHD	10	20
	-		-	-	-
	5.5		HD	15	30
	5.5		ND	15	30

Note: A box (■) in the above table replaces S (Basic type) or E (EMC filter built-in type) depending on the enclosure.
 A box (□) in the above table replaces GA, GB, A, E, U, K or C depending on the model.

⚠ WARNING ⚠

Power supply voltage	Nominal applied motor (kW)	Inverter type	ND/HD/HND mode	MCCB or RCD/ELCB *1 Rated current	
				W/DCR	W/o DCR
Three-phase 400 V	5.5	FRN0022E2■-4□	HHD	15	30
	7.5		HND	20	40
	7.5		HD		
	11		ND	30	50
	7.5	FRN0029E2■-4□	HHD	20	40
	11		HND	30	50
	11		HD		
	15		ND	40	60
	11	FRN0037E2■-4□	HHD	30	50
	15		HND	40	60
	15		HD		
	18.5		ND	40	75
	15	FRN0044E2■-4□	HHD	40	60
	18.5		HND	40	75
	18.5		HD		
	22		ND	50	100
	18.5	FRN0059E2■-4□	HHD	40	75
	22		HND	50	100
	22		HD		
	30		ND	75	125
	22	FRN0072E2■-4□	HHD	50	100
	30		HND	75	125
	30		HD		
	37		ND	100	
	30	FRN0085E2■-4□	HHD	75	125
	37		HND		
	37		HD	100	
	45		ND	150	
	37	FRN0105E2■-4□	HHD	100	125
	45		HND		
	45		HD	150	
	55		ND	125	200
	45	FRN0139E2■-4□	HHD	100	150
	55		HND	125	200
	55		HD		
	75		ND	175	—
	55	FRN0168E2■-4□	HHD	125	200
	75		HND	175	—
	75		HD		
	90		ND	200	
	75	FRN0203E2■-4□	HHD	175	—
	90		HND		
90	HD		200		
110	ND		250		
90	FRN0240E2■-4□	HHD	250	—	
110		HND			
110		HD	250		
132		ND	300		
110	FRN0290E2■-4□	HHD	250	—	
132		HND			
132		HD	300		
160		ND	350		
132	FRN0361E2■-4□	HHD	300	—	
160		HND			
160		HD	350		
200		ND	500		
160	FRN0415E2■-4□	HHD	350	—	
200		HND			
200		HD	500		
220		ND	—		
200	FRN0520E2■-4□	HHD	500	—	
220		HND			
220		HD			
280		ND	600		
220	FRN0590E2■-4□	HHD	500	—	
280		HND			
250		HD	600		
315		ND	800		

Note: A box (■) in the above table replaces S (Basic type) or E (EMC filter built-in type) depending on the enclosure.

A box (□) in the above table replaces GA, GB, A, E, U, K or C depending on the model.

*1 The frame size and model of the MCCB or RCD/ELCB (with overcurrent protection) will vary, depending on the power transformer capacity. Refer to the related technical documentation for details.

⚠ WARNING ⚠

Power supply voltage	Nominal applied motor (kW)	Inverter type	ND/HD/HND mode	MCCB or RCD/ELCB *1 Rated current	
				W/DCR	W/o DCR
Single-phase 200 V	0.1	FRN0001E2■-7□	HHD	5	5
	0.2	FRN0002E2■-7□	HHD	5	5
	0.4	FRN0003E2■-7□	HHD	5	10
	0.75	FRN0005E2■-7□	HHD	10	15
	1.5	FRN0008E2■-7□	HHD	15	20
	2.2	FRN0011E2■-7□	HHD	20	30

Note: A box (■) in the above table replaces S (Basic type) or E (EMC filter built-in type) depending on the enclosure.

A box (□) in the above table replaces GA, GB, A, E, U, K or C depending on the model.

*1 The frame size and model of the MCCB or RCD/ELCB (with overcurrent protection) will vary, depending on the power transformer capacity. Refer to the related technical documentation for details.

5. The inverter should be used in an environment that does not exceed Pollution Degree 2 requirements. If the environment has a Pollution Degree 3 or 4, install the inverter in an enclosure of IP54 or higher.
6. Install the inverter, AC or DC reactor, input or output filter in an enclosure with minimum degree of protection of IP2X (Top surface of enclosure shall be minimum IP4X when it can be easily accessed), to prevent human body from touching directly to live parts of these equipment.
7. Do not connect any copper wire directly to grounding terminals. Use crimp terminals with tin or equivalent plating to connect them.
8. When you use an inverter at an altitude of more than 2000 m, you should apply basic insulation for the control circuits of the inverter. The inverter cannot be used at altitudes of more than 3000 m.
9. Use wires described in Chapter 2 “2.2.5 [1] Screw specifications” and “2.2.5 [3] Recommended wire size (main circuit terminals).”

⚠ WARNING ⚠

10. Use this inverter at the following power supply system.

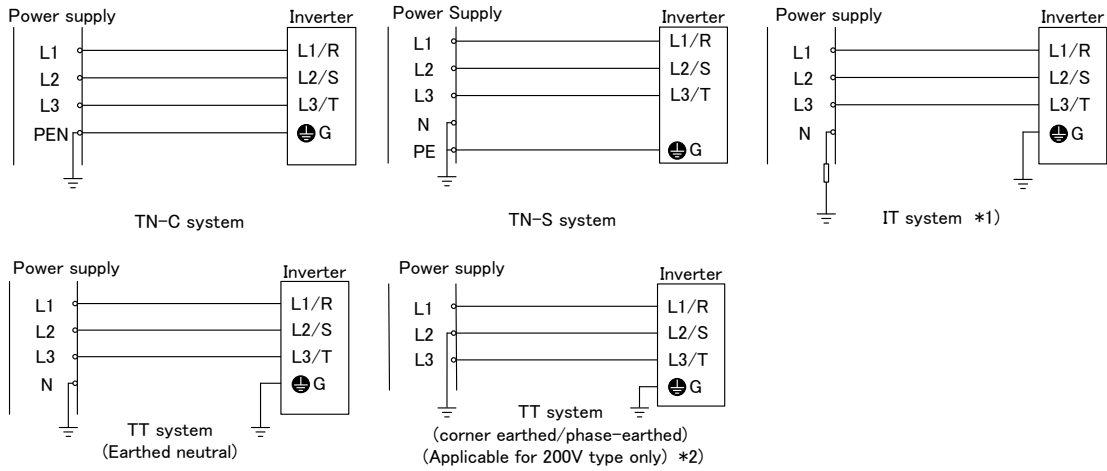

*1 Use this inverter at the following IT system.

Non-earthed (isolated from earth) IT system	Can be used. In this case the insulation between the control interface and the main circuit of the inverter is basic insulation. Thus do not connect SELV circuit from external controller directly (make connection using a supplementary insulation). Use an earth fault detector able to disconnect the power within 5s after the earth fault occurs.
IT system which earthed neutral by an impedance	
Corner earthed / Phase-earthed IT system by an impedance	Can not be used

*2 Cannot apply to Corner earthed / Phase-earthed TT system of 400V type

G.2 Harmonic Component Regulation in the EU

[1] General comments

When you use general-purpose industrial inverters in the EU, the harmonics emitted from the inverter to power lines are strictly regulated as stated below.

If an inverter whose rated input is 1 kW or less is connected to public low-voltage power supply, it is regulated by the harmonics emission regulations from inverters to power lines (with the exception of industrial low-voltage power lines). Refer to Figure G-3 Power Source and Regulation below for details.

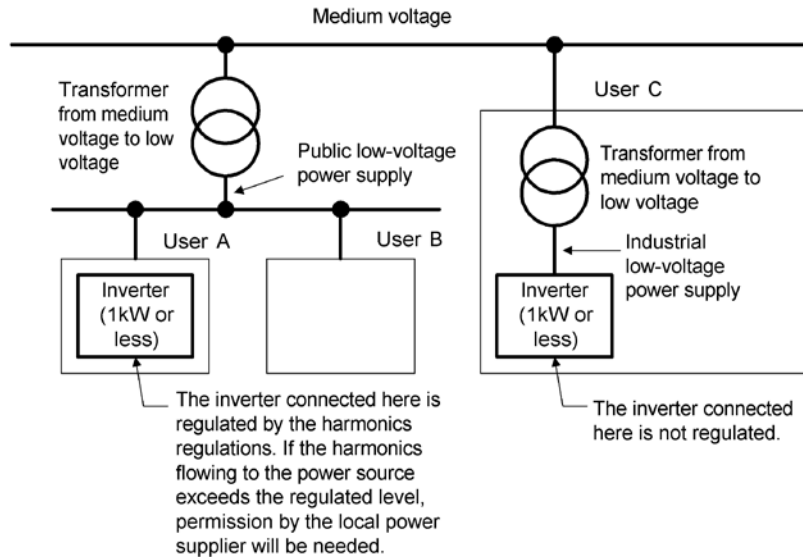

Figure G-3 Power Source and Regulation

[2] Compliance with the harmonic component regulation

Table G-4 Compliance with Harmonic Component Regulation

Power supply voltage	Inverter type	Nominal applied motor(kW)	ND/HD/HND/HHD	w/o DC reactor	w/ DC reactor	Applicable DC reactor type
Three-phase 200 V	FRN0001E2■-2□	0.1	HHD	√*	√*	DCR2-0.2
		0.2	HND	√*	√*	DCR2-0.2
	FRN0002E2■-2□	0.2	HHD	√*	√*	DCR2-0.2
		0.4	HND	√*	√*	DCR2-0.4
	FRN0004E2■-2□	0.4	HHD	√*	√*	DCR2-0.4
		0.75	HND	√*	√*	DCR2-0.75
FRN0006E2■-2□	0.75	HHD	√*	√*	DCR2-0.75	
Three-phase 400 V	FRN0002E2■-4□	0.4	HHD	—	√	DCR4-0.4
		0.75	HND	—	√	DCR4-0.75
	FRN0004E2■-4□	0.75	HHD	—	√	DCR4-0.75
Single-phase 200 V	FRN0001E2■-7□	0.1	HHD	—	√	DCR2-0.2
	FRN0002E2■-7□	0.2	HHD	—	√	DCR2-0.4
	FRN0003E2■-7□	0.4	HHD	—	√	DCR2-0.75
	FRN0005E2■-7□	0.75	HHD	—	—	DCR2-1.5

* Evaluated by the level of harmonics flow to the 400 VAC line when three-phase 200 VAC power is supplied from the three-phase 400 VAC power via a step-down transformer.

G.3 Compliance with UL Standards and Canadian Standards (cUL certification)



Originally, the UL standards were established by Underwriters Laboratories, Inc. as private criteria for inspections/investigations pertaining to fire/accident insurance in the USA. Later, these standards were authorized as the official standards to protect operators, service personnel and the general populace from fires and other accidents in the USA.

cUL certification means that UL has given certification for products to clear CSA Standards. cUL certified products are equivalent to those compliant with CSA Standards.

■ **Notes**

UL/cUL-listed inverters are subject to the regulations set forth by the UL standards and CSA standards (cUL-listed for Canada) by installation within precautions listed below.

⚠ CAUTION

Integral solid state short circuit protection does not provide branch circuit protection. Branch circuit protection must be provided in accordance with the National Electrical Code and any additional local codes.

1. Solid state motor overload protection (motor protection by electronic thermal overload relay) is provided in each model.

Use function codes F10 to F12 to set the protection level, refer to the description below.

F10	Electronic thermal overload protection for motor 1 (Select motor characteristics)	1: Enable (For a general-purpose motor with self-cooling fan) 2: Enable (For an inverter-driven motor with separately powered cooling fan)
F11	(Overload detection level)	0.00 (disable), current value of 1 to 135% of inverter rated current (Inverter rated current dependent on F80)
F12	(Thermal time constant)	0.5 to 75.0 min, Refer to the graph below.

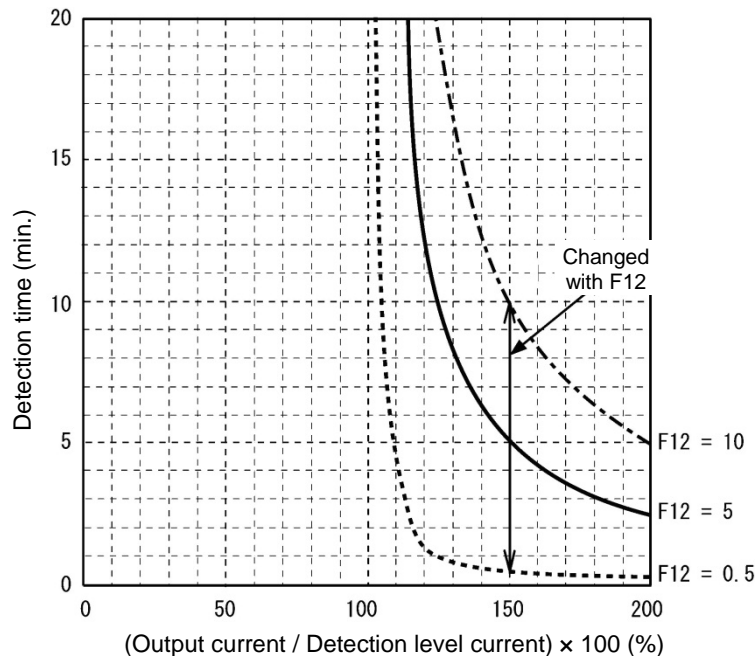

⚠ CAUTION

2. Use Cu wire only.
3. Use Class 1 wire only for control circuits.
4. Short circuit rating
 - For Models FRN0001 to 0006E2■-2□, FRN0088 to 0115E2■-2□ and FRN0001 to 0005E2■-7□:
 "Suitable For Use On A Circuit Of Delivering Not More Than 100,000 rms Symmetrical Amperes, 240 Volts Maximum when Protected by a Class J or Class CC Fuses or a Circuit Breaker Having An Interrupting Rating Not Less Than 100,000 rms Symmetrical Amperes, 240 Volts minimum."
 - For Models FRN0010 to 0069E2■-2□ and FRN0008 to 0011E2■-7□:
 "Suitable For Use On A Circuit Of Delivering Not More Than 100,000 rms Symmetrical Amperes, 240 Volts Maximum when protected by Class J or Class CC Fuses.". May be provided on the instruction manual.
 - For Models FRN0002 to 0044E2■-4□:
 "Suitable For Use On A Circuit Of Delivering Not More Than 100,000 rms Symmetrical Amperes, 480 Volts Maximum when protected by Class J or Class CC Fuses."
 - For Models FRN0059E2■-4□ or above:
 "Suitable For Use On A Circuit Of Delivering Not More Than 100,000 rms Symmetrical Amperes, 480 Volts Maximum when protected by Class J or Class CC Fuses or a Circuit Breaker Having An Interrupting Rating Not Less Than 100,000 rms Symmetrical Amperes, 480 Volts minimum."
5. Field wiring connections must be made by a UL Listed and CSA Certified closed-loop terminal connector sized for the wire gauge involved. Connector must be fixed using the crimp tool specified by the connector manufacturer.
6. All circuits with terminals L1/R, L2/S, L3/T, L1/L, L2/N, R0, T0, R1, T1 must have a common disconnect and be connected to the same pole of the disconnect if the terminals are connected to the power supply.

Connection diagram of the three phase input type.

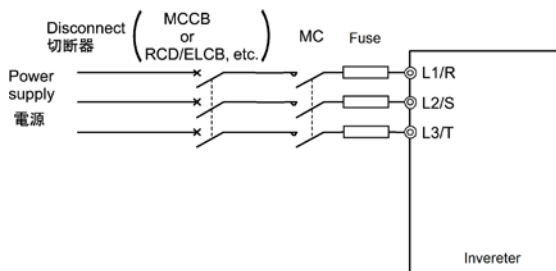

FRN0020E2■-2□ or below
FRN0012E2■-4□ or below

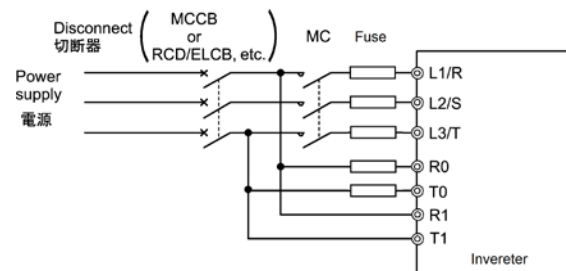

FRN0030E2■-2□ or above
FRN0022E2■-4□ or above

Connection diagram of the single phase input type.

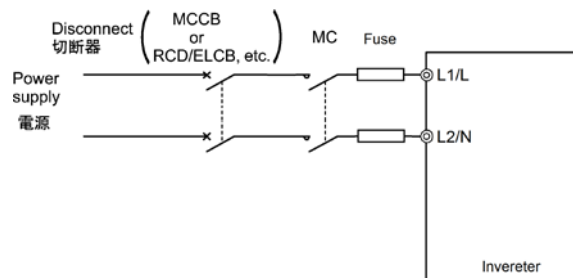

FRN0011E2■-7□ or below

⚠ CAUTION

7. Environmental Requirements

7.1 Type FRN0030E2■-2□/FRN0022E2■-4□ or above

- Maximum Surrounding Air Temperature / Maximum ambient temperature
The ambient temperature shall be lower than the values in the table below.

Enclosure Type	ND/HD	HND/HHD
Open Type	40 deg C	50 deg C
Enclosed Type	40 deg C	40 deg C

- Atmosphere
For use in pollution degree 2 environments (for Open-Type models).

7.2 Type FRN0020E2■-2□/FRN0012E2■-4□/ FRN0011E2■-7□ or below

- Maximum Surrounding Air Temperature
The surrounding air temperature shall be lower than the values in the table below.

Enclosure Type	ND/HD	HND/HHD
Open Type FRN0010E2■-2□ or below FRN0006E2■-4□ or below FRN0011E2■-7□ or below	40 deg C	50 deg C
Open Type FRN0012E2■-2□ FRN0020E2■-2□ FRN0007E2■-4□ FRN0012E2■-4□	40 deg C	50 deg C (HHD) 40 deg C (HND)

- Atmosphere
For use in pollution degree 2 environments (for Open-Type models).

8. UL Enclosure Type

UL Enclosed Type formats are shown in the table below.

Variation	Enclosed Type1
Standard	FRN0030 to 0115E2U-2□ FRN0022 to 0590E2U-4□
EMC Filter	FRN0030 to 0115E2F-2□ FRN0022 to 0590E2F-4□

The other models of above table are excluded.

9. Plenum rated drives

UL Enclosed Type is Suitable for installation in a compartment handling conditioned air. Models of FRN0020E2■-2□/FRN0012E2■-4□/FRN0011E2■-7□ or below are excluded.

10. Functional Description of Control Circuit Terminals

A power source for connection to the Integrated alarm output (30A, 30B, 30C) should be limited to overvoltage category II such as control circuit or secondary winding of power transformer.

Classification	Terminal Symbol	Terminal Name	Functional description
Contact output	[30A/B/C]	Integrated alarm output	When the inverter stops with an alarm, output is generated on the relay contact (1C). Contact capacitance: AC250 V 0.3A cosφ=1, DC30 V 0.5 A

⚠ CAUTION

11. All models rated 380-480 V input voltage ratings shall be connected to TN-C system power source, i.e. 3-phase, 4-wire, wye (480Y/277V), so that the phase-to-ground rated system voltage is limited to 300V maximum.
12. Install UL certified fuses or circuit breaker between the power supply and the inverter, referring to the table below.

Power supply voltage	Nominal applied motor(kW)[HP]	Inverter type	HHD/HD/HND/ND mode	Class J or Class CC fuse size (A) *4	Circuit breaker trip size (A) *5	Required torque lb-in (N · m)		Wire size AWG (mm ²)																
						Main terminal	Inverter's grounding	Aux. control power supply	Aux. Fan power supply	Main terminal Cu Wire						Inverter's grounding	Aux. control power supply	Aux. fan power supply						
										L1/R,L2/S,L3/T			U, V, W						G					
										60°C Cu wire	75°C Cu wire	Remarks	60°C Cu wire	75°C Cu wire	Remarks									
Three-phase 200V	0.1 [1/8]	FRN0001E2■-2□	HHD	3	5	7.1 (0.8)	10.6 (1.2)																	
	0.2 [1/4]	FRN0001E2■-2□	HND	3																				
		FRN0002E2■-2□	HHD	6																				
		FRN0002E2■-2□	HND	6																				
	0.4 [1/2]	FRN0004E2■-2□	HHD	10																				
		FRN0004E2■-2□	HND	10																				
	0.75 [1]	FRN0004E2■-2□	HHD	10	10																			
		FRN0006E2■-2□	HND	10																				
	1.1 [1.5]	FRN0006E2■-2□	HHD	15																				
		FRN0006E2■-2□	HND	15																				
	1.5 [2]	FRN0010E2■-2□	HHD	20																				
		FRN0010E2■-2□	HND	20																				
	2.2 [3]	FRN0012E2■-2□	HHD	30	30	10.6 (1.2)	15.9 (1.8)																	
		FRN0012E2■-2□	ND	30																				
	3.0 [4]	FRN0020E2■-2□	HHD	40																				
		FRN0020E2■-2□	HND	40																				
	3.7 [5]	FRN0020E2■-2□	ND	50																				
		FRN0020E2■-2□	HND	50																				
	5.5 [7.5]	FRN0030E2S-2□	HHD	60	-																			
		FRN0030E2S-2□	ND	60																				
	7.5 [10]	FRN0040E2S-2□	HHD	75																				
		FRN0040E2S-2□	HND	75																				
	11 [15]	FRN0056E2S-2□	HHD	100																				
		FRN0056E2S-2□	HND	100																				
15 [20]	FRN0069E2S-2□	HHD	150	-																				
	FRN0069E2S-2□	HND	150																					
18.5 [25]	FRN0088E2■-2□	HHD	175																					
	FRN0088E2■-2□	HND	175																					
22 [30]	FRN0115E2■-2□	HHD	200																					
	FRN0115E2■-2□	HND	200																					
30 [40]	FRN0115E2■-2□	HHD	250	-																				
	FRN0115E2■-2□	HND	250																					
5.5 [7.5]	FRN0030E2E-2□	HHD	60																					
	FRN0030E2E-2□	HND	60																					
7.5 [10]	FRN0040E2E-2□	HHD	75																					
	FRN0040E2E-2□	HND	75																					
11 [15]	FRN0056E2E-2□	HHD	100	-																				
	FRN0056E2E-2□	HND	100																					
15 [20]	FRN0069E2E-2□	HHD	150																					
	FRN0069E2E-2□	HND	150																					
18.5 [25]	FRN0069E2E-2□	HHD	175																					
	FRN0069E2E-2□	HND	175																					

Note: A box (■) in the above table replaces S (Basic type) or E (EMC filter built-in type) depending on the enclosure.
 A box (□) in the above table replaces GA, GB, A, E, U, K or C depending on the model.

⚠ CAUTION

Power supply voltage	Nominal applied motor(kW)[HP]	Inverter type	HHD/HD/HND/ND mode	Class J or Class CC fuse size (A) *4	Circuit breaker trip size (A) *5	Required torque lb-in (N · m)				Wire size AWG (mm ²)								
						Main terminal	Inverter's grounding	Aux. control power supply	Aux. Fan power supply	Main terminal Cu Wire					Inverter's grounding	Aux. control power supply	Aux. fan power supply	
										L1/R,L2/S,L3/T			U, V, W					Remarks
										60°C Cu wire	75°C Cu wire	Remarks	60°C Cu wire	75°C Cu wire				
Three-phase 400V	5.5 [7.5]	FRN0022E2E-4□	HHD	30	input 15.9 (1.8) other 27 (3.0)	27 (3.0)	-	-	-	12 (3.3)	-	-	14 (2.1)	10 (5.3)	-	-		
	7.5 [10]	FRN0022E2E-4□ FRN0029E2E-4□	HND HHD	40						10 (5.3)			12 (3.3)					
	11 [15]	FRN0029E2E-4□ FRN0037E2E-4□	HND HHD	60	input 15.9 (1.8) other 51.3 (5.8)	51.3 (5.8)	-	-	-	8 (8.4)	-	-	10 (5.3)	8 (8.4)	-	-		
	15 [20]	FRN0037E2E-4□ FRN0044E2E-4□	HND HHD	70						8 (8.4)			10 (5.3)					
	18.5 [25]	FRN0044E2E-4□	HND	90						6 (13.3)			6 (13.3)					
	Single-phase 200V	0.1 [1/8]	FRN0001E2■-7□	HHD	6	7.1 (0.8)	10.6 (1.2)	-	-	-	14 (2.1)	-	-	14 (2.1)	-	-	-	
0.2 [1/4]		FRN0002E2■-7□	HHD	6	5													
0.4 [1/2]		FRN0003E2■-7□	HHD	10	10													
0.75 [1]		FRN0005E2■-7□	HHD	20	15	12 (3.3)	10 (5.3)											
1.5 [2]		FRN0008E2■-7□	HHD	30	10.6 (1.2)			15.9 (1.8)										
2.2 [3]		FRN0011E2■-7□	HHD	50	10 (5.3)	10 (5.3)												

Note: Control circuit terminals M2 tightening torque: 1.7 lb-in (0.19 N·m) ±10%
 Recommended wire size: AWG26 to 18 (0.14 to 1 mm²)
 M3 tightening torque: 4.4 to 5.3 lb-in (0.5 to 0.6 N·m), recommended wire size: AWG26 to 16 (0.14 to 1.5 mm²)

Note: A box (■) in the above table replaces S (Basic type) or E (EMC filter built-in type) depending on the enclosure.
 A box (□) in the above table replaces GA, GB, A, E, U, K or C depending on the model.

- *1 No terminal end treatment is required for connection.
- *2 Use 75°C (167°F) Cu wire only.
- *3 The wire size of UL Open Type and Enclosed Type are common. Please contact us if UL Open Type exclusive wire is necessary.
- *4 6 rms Amperes for aux. control power supply. There is no aux. control power supply in FRN0020E2■-2□ /FRN0022E2■-4□/FRN0011E2■-7□ or below.
- *5 5 rms Amperes for aux. control power supply. There is no aux. control power supply in FRN0020E2■-2□ /FRN0022E2■-4□/FRN0011E2■-7□ or below.

G.4 Compliance with the Radio Waves Act (South Korea) (㉸)

한국 전파법 대응

본제품은 한국전파법에 적합한 제품입니다.

한국에서 사용시는 아래에 주의하여 주시기 바랍니다.

“이 기기는 업무용(A 급) 전자파 적합기기로서 판매자 또는 사용자는

이점을 주의하시기 바라며, 가정외의 지역에서 사용하는 것을 목적

으로 합니다. 해당제품은 형식 FRN△△△E2■-□GA/GB/A/E/U/K/C 의 제품만 대상이 됩니다.

(△는 인버터용량, □는 전압시리즈를 표시하는 숫자 2 또는 4 가 표기됩니다.)

Compliance with the Radio Waves Act (South Korea)

This product complies with the Radio Waves Act (South Korea)

Note the following when using the product in South Korea

(The product is for business-use (Class A) and meets the electromagnetic compatibility requirement. The seller and the user must note the above point, and use the product in a place except for home.)

Only the following type of the products is applicable to this certification.

Type: FRN△△△E2■-□GA/GB/A/E/U/K/C

(△: indicates inverter output power and □: indicates if the power supply voltage 2 or 4 is.)

High Performance Inverter
FRENIC-Ace

Instruction Manual

First Edition, February 2013

Sixth Edition, March 2015

Fuji Electric Co., Ltd.

The purpose of this Instruction manual is to provide accurate information in handling, setting up and operating of the FRENIC-Ace series of inverters. Please feel free to send your comments regarding any errors or omissions you may have found, or any suggestions you may have for generally improving the manual.

In no event will Fuji Electric Co., Ltd. be liable for any direct or indirect damages resulting from the application of the information in this manual.

Fuji Electric Co., Ltd.

Gate City Ohsaki, East Tower, 11-2, Osaki 1-chome, Shinagawa-ku, Tokyo, 141-0032, Japan

Phone: +81 3 5435 7058 Fax: +81 3 5435 7420

URL <http://www.fujielectric.com/>