

MODEL CXJ8106

EXPLOSION PROOF ENCLOSURE - DIMENSIONAL DRAWING
UL and CSA RATED FOR HAZARDOUS LOCATIONS



Instrument electronics are housed in this optional solid aluminum enclosure rated Class I, Groups B,C,D Class II, Groups E,F,G Class III. It includes a hinged door and all bolts.

The backlit instrument display is visible through the viewing window and the calibration keypad is magnetically activated with the supplied pointer.

Enclosure conduit entries drilled by Customer.

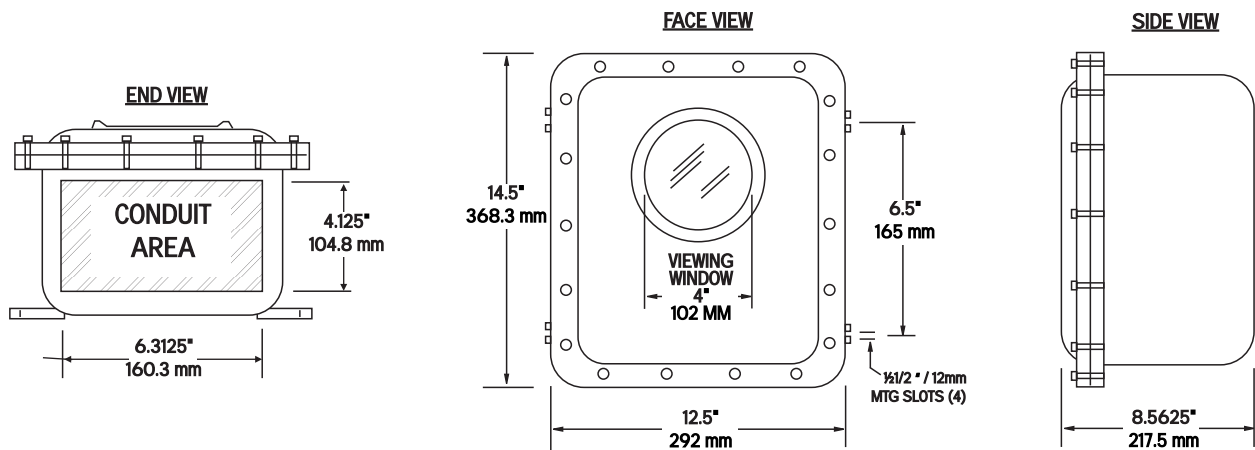

COMPLIANCE: NEMA 4, 7 AND 9

CERTIFIED BY UL AND CSA FOR USE IN CLASS I, GROUPS B, C and D, CLASS II, GROUPS E, F and G HAZARDOUS RATED LOCATIONS

NOTES:

- APPROXIMATE SHIPPING WEIGHT: 44 LBS (20 Kg)
- ELECTRICAL CONNECTIONS BY INTERNAL TERMINALS. UNDO FLANGE BOLTS FOR ACCESS. DO NOT UNSCREW VIEWING WINDOW