

	Instruction Manual DTG LCD SERIES Digital Temperature Gauge Battery Powered	Document No.: DTG_LCD_en Rev. : 1.0	Issue Date : 20/02/2013
		Firm. Rev.:	Rev. Date : 22/02/2013

DTG - LCD
Digital Temperature Gauge
USER MANUAL

	Instruction Manual DTG LCD SERIES Digital Temperature Gauge Battery Powered	Document No.: DTG_LCD_en Rev. : 1.0	Issue Date : 20/02/2013
		Firm. Rev.:	Rev. Date : 22/02/2013

USERS GUIDE

	page
1. Description	3
2. Function	3
3. Safety Instruction	3
3.1. Safety Conventions	3
3.2. Proper Use	3
4. Installation	4
4.1. Unpacking	4
4.2. Storage	4
4.3. Orientation	4
4.4. Troubleshooting	4
5. Limits	5
5.1. Pressure Limits	5
5.2. Temperature Limits	5
5.3. Thermal Characteristics	5
5.4. Response Time	5
6. Calibration	5
7. Long Term Stability	5
8. Error Codes	5
9. Dimensions	6
10. Technical Specifications	7



Instruction Manual

DTG LCD SERIES

Digital Temperature Gauge

Battery Powered

Document No.:
DTG_LCD_en Rev. : 1.0

Issue Date :
20/02/2013

Firm. Rev.:

Rev. Date :
22/02/2013

1. Description

The DTG series Digital Temperature Gauges are a complete solution for most industrial temperature monitoring and temperature indicating applications. Of high quality construction, these gauges features a large 4-digit LCD display. They are designed for optimum accuracy and performance. The series DTG are an ideal replacement for bi-metal, liquid bulb and gas thermometers. They are also a suitable replacement for Mercury reduction programs.

The DTG arrives factory calibrated to the customer's specified temperature range. No costly field calibration is required.

Housing, probe and fitting material is all fabricated from stainless steel 316. The DTG is rated to NEMA 4X (IP65). Many mounting configurations are available to meet customer requirements.

The DTG has a five year battery life with a low battery indication on the LCD.



2. Function

The DTG line of thermometers uses a Pt1000 Platinum RTD sensor which is read by our embedded processor and displayed on the LCD display.

The LCD based DTG is battery powered and needs no wiring unless there are options chosen that require it.

3. Safety Instruction

Read the instruction manual completely before installing the DTG temperature sensor. All safety guidelines should be followed and the sensor should only be installed by qualified personel following all local codes and regulations.

3.1. Safety Conventions

The following symbols should be noted in this instruction manual.



Attention: this symbol indicates an instruction that if not followed properly could lead to injury or death.



Note: this symbol indicates an action that could lead to damage or contamination if not followed.

3.2. Proper Use

3.2.1. Designated use: These devices are intended for specific industrial applications. Appropriate fittings, materials and form must be chosen depending on the use. Proper specification must be done to conform with temperature, pressure and flow velocity requirements.

3.2.2. Installation: these devices must be installed by qualified personel taking all necessary precautions. The installation should adhere to all local regulations.

3.2.3. Ensure that the label on the DTG is correct and that the model is appropriate for the particular application.

3.2.4. These devices are repairable. In the event of failure they should be returned to the factory for repair and recalibration. Please ensure the unit is clean and has no contaminants before returning.

3.2.5. If the installation will occur in a hazardous location or near hazardous materials all necessary precautions should be taken.



3.2.6. Mounting locations should be chosen to avoid high voltage electrical lines and for ease of installation and future maintenance.





Instruction Manual

DTG LCD SERIES

Digital Temperature Gauge

Battery Powered

Document No.:
DTG_LCD_en Rev. : 1.0

Issue Date :
20/02/2013

Firm. Rev.:

Rev. Date :
22/02/2013

4. Installation

4.1. Unpacking

If there is any visible damage to the unit check the packaging and notify the shipper immediately. Included in the package should be one DTG and one instruction manual.

- 4.2. Storage: note that the device should be stored at a temperature between -20°C to $+70^{\circ}\text{C}$ (-4°F to 160°F) in a location that is reasonably dry and clean.

4.3. Orientation: see figure 1.

There are no restrictions on the orientation of the probe installation location, but if there is a requirement for the pipe to be self draining the seating should be angled such that it will drain properly.

The probe should be centered in the process flow no matter what the orientation. Angled inserts should have the probe pointing into the direction of flow as shown.

Ensure that during installation all necessary precautions are taken. If this is a sanitary installation ensure that the probe has been properly cleaned in advance of installation and ensure that it is transported to the site of installation in a way that will maintain its sanitary condition.

If there are flammable or explosive fluids or gasses present at the site of installation ensure that proper grounding procedures are taken. Unwrapping a probe from bubble wrap or other packaging can impart a static charge on the probe which may discharge upon insertion into the mounting location. 

If the function demands it, seal the process connection with Teflon tape.

Note: NPT connections should be hand tightened and then turned only 1-1/2 turns further with an appropriate wrench. This value may change according to what type of sealant is used on the pipe threads. Do not use the display body to tighten the probe into the mounting location. Doing so may damage the probe. Use only the process connection or compression fitting for tightening.

4.4. Troubleshooting

If the unit fails to function properly there are no user serviceable parts inside. If returning the unit to Intempco please ensure that the unit is clean and free from any contaminants before shipping.

5. Wiring

Note that the LCD based DTG is a battery powered device and needs no wiring unless it has been ordered with an option that requires wiring.

Figure 1

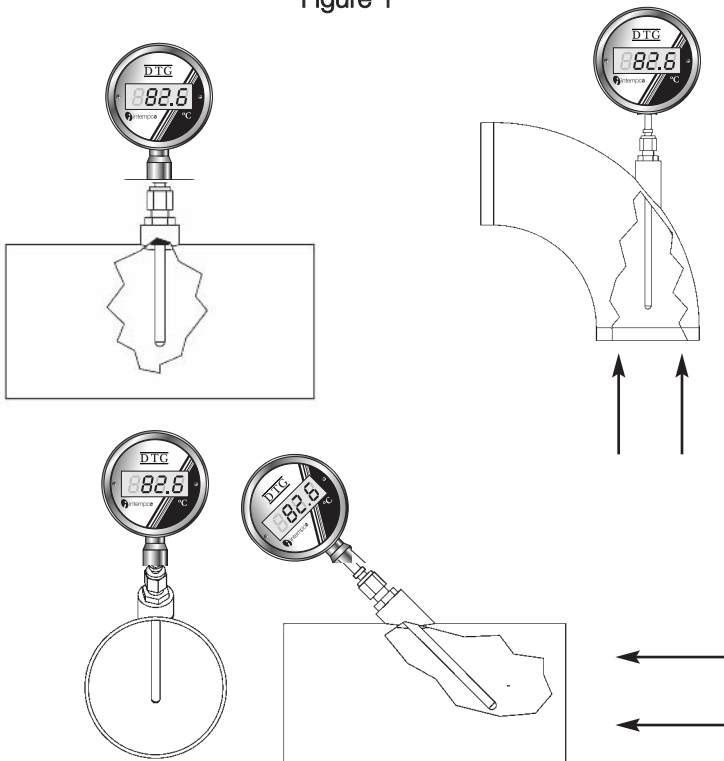

	Instruction Manual DTG LCD SERIES Digital Temperature Gauge Battery Powered	Document No.: DTG_LCD_en Rev. : 1.0	Issue Date : 20/02/2013
		Firm. Rev.:	Rev. Date : 22/02/2013

5. Limits

5.1. Pressure Limits

The pressure limits for the probe is 500 psig, but the pressure limits for the process connection could be considerably less. Ensure the appropriate process connection is used for the desired pressure limits.

5.2. Temperature Limits

The ambient temperature range for the exterior housing enclosing the processor should not exceed 0°C to 50°C (32°F to 120°F). The temperature limits for the probe should conform to the following table according to the unit ordered.

BOX1 CODE	Temperature Range
CL	Low Temp., display °C -50 to 200°C
FL	Low Temp., display °F -58/392°F

Note that the temperature will affect the pressure and flow velocity limits of the probe.

5.3. Thermal Characteristics

For some RTD temperature indicators there is self heating from the measurement current. With Intempco DTG products the self heating is negligible. Any self heating error will be compensated for during factory calibration.

Calibration of all Intempco DTG products takes place after the RTD, probe and electronics are assembled and immersed up to the process connection or a minimum of 10X the probe diameter. There should be no discrepancy in the measurement due to the thermal characteristics of the probe or process fitting.

5.4. Response Time

Warm up is approximately 30 seconds, then response time is typically 3 seconds due to the display refresh rate.

6. Calibration

Calibration is performed at the factory. For recalibration return the unit to the factory. Please ensure that the unit is clean and free of contaminants before shipping. On site calibration may only be conducted by an Intempco authorized representative or by factory trained professionals.

7. Long-Term Stability

The electronics and RTD should not deviate more than 0.05% per year if sized and installed properly. Regularly scheduled verification should be done to ensure that the unit is within accepted norms.

8. Error Codes

The DTG is programmed to display the following error conditions.

- Err1 Shorted RTD condition
- Err2 Open RTD condition
- Err3 General Error
- LO Valid reading, but out of display range low
- Hi Valid reading, but out of display range hi
- bAtt Battery voltage is low - return to factory for battery replacement and recalibration.



Instruction Manual
DTG LCD SERIES
 Digital Temperature Gauge
 Battery Powered

Document No.:
 DTG_LCD_en Rev. : 1.0

Issue Date :
 20/02/2013

Firm. Rev.:

Rev. Date :
 22/02/2013

9. Dimensions & Mounting Options

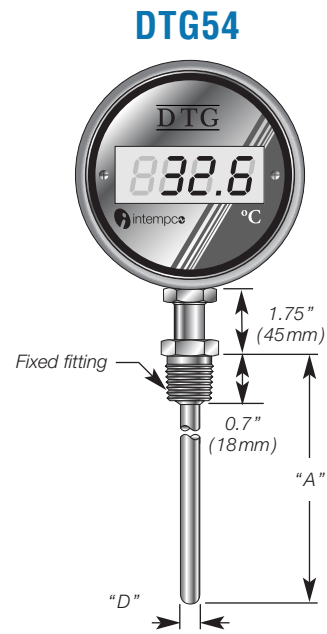
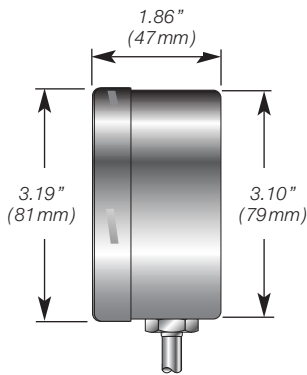
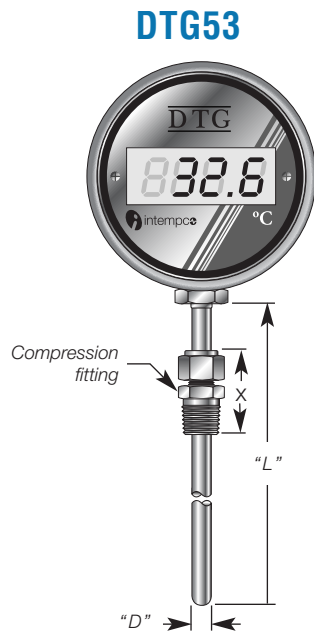

NPT	"X"
1/8"	1.23" (31)
1/4"	1.50" (38)
3/8"	1.50" (38)
1/2"	1.76" (45)
3/4"	1.82" (46)



Instruction Manual

DTG LCD SERIES

Digital Temperature Gauge

Battery Powered

Document No.:
DTG_LCD_en Rev. : 1.0

Issue Date :
20/02/2013

Firm. Rev.:

Rev. Date :
22/02/2013

10. TECHNICAL SPECIFICATIONS

Sensing Element :	RTD, Type Pt1000 Ohm, Class A
Measuring Temperature Ranges :	-50°C to 200°C (-58°F to 392°F) or -200°C to 600°C (-328°F to 1112°F) depending model.
Accuracy :	±(0.2 + 0.002 x ITI) °C, factory, ±(0.36 + 0.002 x IT-32I) °F, factory, ±(0.2 + 0.001 x ITI) °C, option, ±(0.36 + 0.001 x IT-32I) °F, option
Refresh Rate :	3 seconds
Display :	4-digit LCD, 1/2" high (12.7 mm), decimal point selectable by software
Display Resolution :	See table 1
Display Error Messages :	See operational manual
RFI effect :	1% or less typical
Temp. Effect :	<0.01 % FS/°C
Ambient Temp. Range :	0°C to 50°C (32°F to 122°F)
Storage Temp. Range :	-20°C to 70°C (-4°F to 158°F)
Max. Pressure :	500 PSIG (on probe)
Housing Material :	Stainless steel 316
Probe Material :	Stainless steel 316 standard
Cable Materials :	PVC, Teflon®, Silicone, SS armored Teflon® (with RTD output only)
Weight :	350 grams (12 ounces)
Environmental Protection :	NEMA 4X/IP67
Power :	2 x 3.6 V "AA Cells"
Battery Life :	5 years min. in continuous mode (low power battery indication)
Electrical Connection :	Micro-DC male plug or cable only (with RTD output only)
RTD Output Option:	RTD, Type Pt100 or Pt1000 Ohm, 2,3,4-wire, Class A DIN IEC 60715
Communication Option:	Communication option allows qualified users to calibrate, change measuring units and resolution. DTGLCD-PKIT required, order separately.
Shipping Volume :	Imperial Volume = 3.5"W X 3"H X (4.7" + L "of probe) Metric Volume = 9.0cm W X 8cm H X (12cm + Lcm of probe)

Table 1: Display Resolution

Model Range	Factory Settings		Optional Settings			
	Setting	Viewable Range	Setting	Viewable Range	Setting	Viewable Range
-50°C to 200°C (-58°F to 392°F)	0.1	-58.0 to 392.0	0.01	-58.00 to 99.99	1	-58 to 392
-200°C to 600°C (-328°F to 1112°F)	1	-328 to 1112	0.01	-99.99 to 99.99	1	-200 to 600

Teflon® is a registered trademark of E.I. du Pont de Nemours and Company.

Installation Considerations

Installation requirements of the DTG are similar to those of the temperature sensor assemblies with head mounted hockey puck transmitter and display. If the temperature of the electronics in the housing exceeds 80°C, permanent damage to the DTG will occur. In all applications, careful attention must be placed on correct installation. For these applications, a remote probe wall mount unit or remote probe panel mount unit, may be a better choice. It is the installer's, customer's and/or end user's responsibility to make sure that this over exposure to temperature does not occur due to improper installation.