



Instruction Manual

LTX60

Capacitance Level Probe

Document No. :
LTX60_DN_M Rev. : 1.0

Issue Date :
16/04/2012

Software Rev. :
remo_v02 or higher

Rev. Date :
10/03/2003

DESCRIPTION (DIN Rail Version)

Intempco LTX60 level transmitter is compact and vibration resistant. It is designed to measure liquids in metal tanks. In non-metal tanks, Intempco recommends the use of Model LTX60. The 12-36 VDC 4 mA base current is the supply to the unit. The LTX60 monitors level change by converting movement of media up or down the probe into pulse wave form which is proportional to changes in level. The amplifier converts this pulse wave into 4 to 20mA output signal. The conversion of level movement to an electrical signal is due to changes in electrical capacitance. The probe and a ground reference electrode, usually the metal tank wall, have a certain capacitance in air. As the medium displaces the air, a change occurs because of the difference in the dielectric constants of the medium and air.

The LTX60 comes complete with probe housing or fitting (Fig. 1), bare stainless or Teflon clad probe, and cable or connector. Signal conditioning electronics are potted within the probe metal housing. Calibration is made via four push buttons, located on a remote transmitter, as explained later.

INSTALLATION

Unpacking

When unpacking the unit be certain that the packing is not damaged. Unpack the instrument carefully. Inspect all components for damage. If the unit is damaged in shipping contact the shipper immediately.

Check the contents of the packing slip and report any discrepancies to Intempco. All sensors are calibrated and tested before leaving Intempco, but if there are any problems report them immediately.



Fig 1.

Installation Location

The Intempco LTX60 level sensor should be located for easy access for service, calibration and monitoring. Probe housing or fitting should not be exposed to ambient temperatures below -40°C (-40°F) or above $+70^{\circ}\text{C}$ ($+160^{\circ}\text{F}$). Special precaution should be made to prevent exposure to corrosive atmosphere, excessive vibration, shock or physical damage. It is preferable that the LTX60 is not installed in proximity to high voltage wires or other sources of high electrical noise.

Metal Walled Tanks

It is a common practice to use the metal tank wall as the reference electrode when using a capacitive sensor, but the LTX60 needs no such reference. It is not required for the housing to make a good electrical connection to the tank wall. If there are any noise problems often they can be resolved by isolating the probe from the tank through use of teflon tape or other isolating methods. If the fluid being measured is causing buildup or clogging issues within the walls of the probe it may be advisable to use the LTX50 open bodied probe in a metal walled tank.

Non-Conductive Tanks / Silos

Plastic, concrete, wood, or any other non-conductive walled vessels will not adversely affect the LTX60. This sensor does not rely on an electrical connection to the wall of the tank and therefore is not affected by the material.

CAUTION : When installing units with teflon (or plastic) coated rods or cables, be careful not to damage the insulation. NPT threads have very sharp corners and Teflon (or plastic) can be easily cut. In acidic and/or conductive liquids damaged units may malfunction.

WIRING

LTX60 comes either with an extension cable or M12 connector. With an extension cable, the unit can be connected to the transmitter directly as shown in Fig. 2. With M12 connector, use a standard 4 or 5-pin M12 female extension cord. All wiring between the remote hoceky puck transmitter and the power supply should be done with 18 to 22 AWG shielded (twisted) wire. The connection is made at the terminal strip of the transmitter enclosure. See Fig. 2.

CAUTION : *Units are designed to operate on 12 to 36V DC power only. Application of 110V AC will destroy the instrument.*

1. Make sure the loop power source is turned off.
2. Pull power supply wires through conduit connection.
3. Connect the positive supply wire to the (+loop) "G" terminal, and the negative supply to the (-loop) "J" terminal.

NOTE : *If using shielded wire, leave shield unattached at the transmitter. Connect the shield to ground at the power source.*

4. To connect the remote probe to the transmitter, bring extension cable or M12 cordset to the transmitter.

5. Connect the 3 probe wires to the DIN Rail terminals as shown in Fig. 2. Green wire (if present) is not used.
6. Connect the drain wires from the shields to the "J" terminal (if used) and if output noisy.
7. Turn ON the power. The meter may read anywhere on the scale at either end. This is normal until calibration has been completed. Proceed to the calibration instructions.

CALIBRATION

Current Meter

In order to calibrate the transmitter, you must use the loop current meter (or calibrator). It should read currents in the range of 1.00 to 25.00 mA, with a resolution of .01 mA. Using a meter of less resolution will somewhat reduce the calibration accuracy. To calibrate the instrument :

1. Connect the loop current meter as per instructions in WIRING section and Fig. 2.
2. Turn the power ON.
3. The loop current should now be in the range of 3 mA to 35 mA, which is normal at this point.

Wire Color Code

	M12	Cable
D	Brown	Red
E	Black	Black
F	White	White

Fig. 2

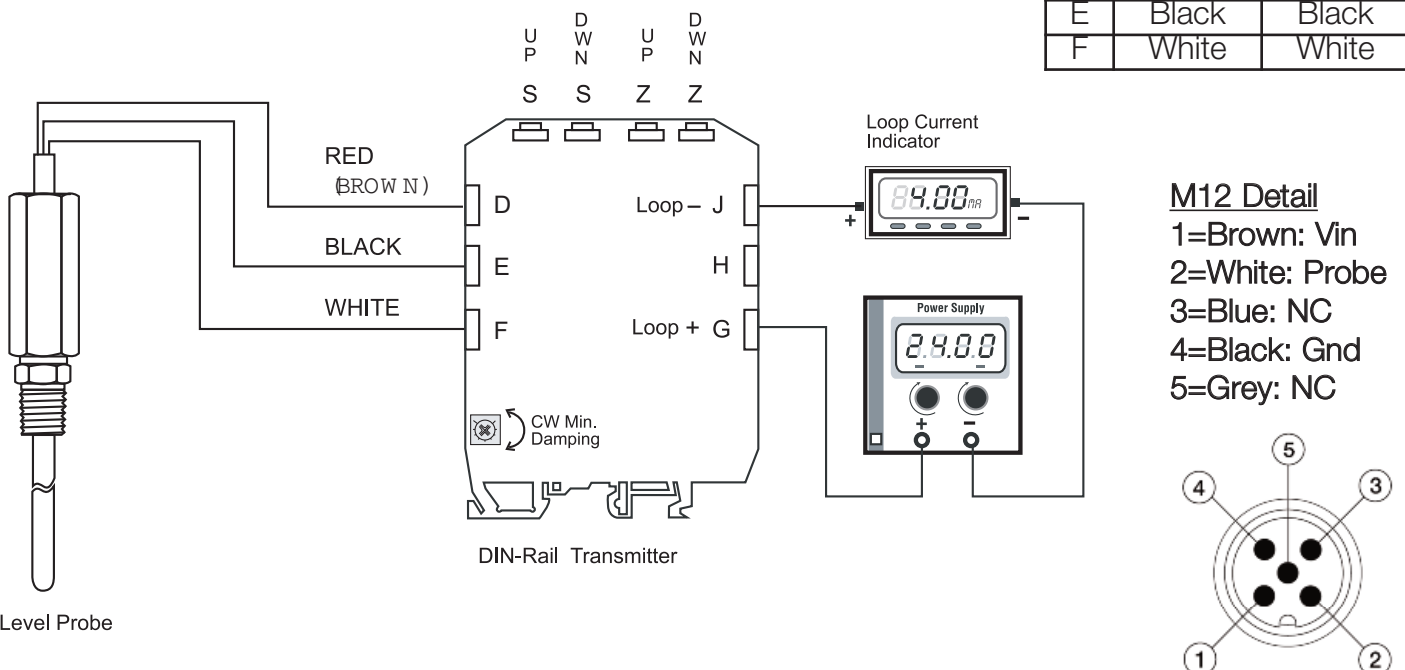

Two Point Calibration - Level Decrease

Three calibration procedures are described. Follow the one which fits your application. Note the following definitions used in the calibration procedures, referring to Fig 3.

- L** = the level of material which corresponds to 4.00mA of loop current, i.e., the 0%
- L1** = a material level higher than L
- H1** = a material level higher than L1, but less than H.
- H** = the level of material in the vessel which corresponds to 20.00 mA of loop current, i.e., the 100% level.

NOTE : To avoid the possibility of a "dead zone", L must be at least two (2) inches above the end of the probe for conductive media and four (4) inches above for non-conductive media.

CALIBRATION L - H = when material in tank can be set to L (0%) and H (100%).

CALIBRATION L - H1 = when material in tank can be set to L (0%) and H1 (less than 100%).

CALIBRATION L1 - H1 = when material in tank can be set to L1 (greater than 0%) and H1 (less than 100%).

NOTE : Calibration procedure L - H gives the most accurate results and is the recommended procedure in all cases.

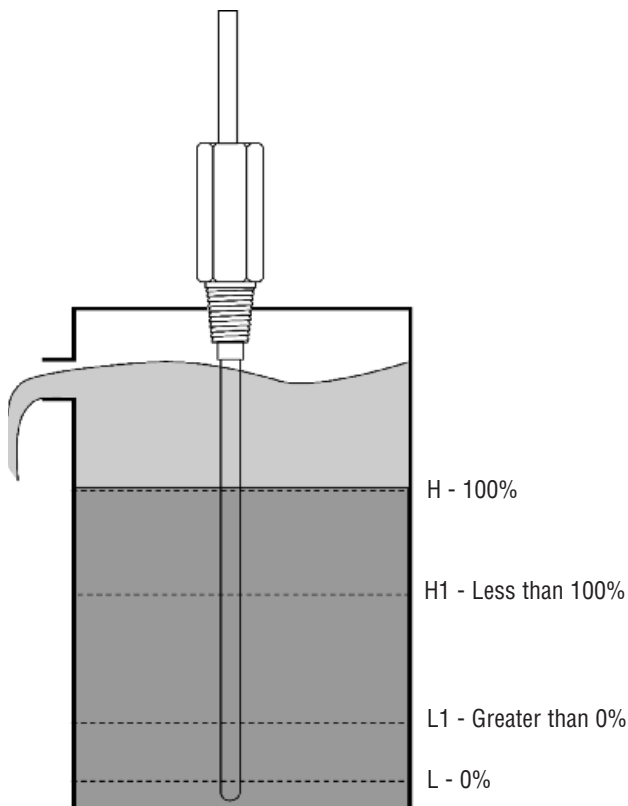

Fig. 3

RESET AND OFFSET FUNCTIONS

CAUTION : There may seem to be a malfunction with the transmitter when the 4-20 mA power loop is activated for the first time. The mA reading may be below 4 mA or above 20 mA and pressing the Z and S push buttons does not change the output.

NOTE : Push buttons may have to be depressed for up to a minute before the value changes.

To re-initialize the transmitter, follow the OFFSET and RESET function instructions below.

OFFSET and RESET functions (or values) are factory set. They may have to be changed by the customer in special cases only. Follow the procedures below.

To re-OFFSET the transmitter, lower the level in the tank to below the probe. Press Z-UP and S-UP push buttons at the same time, then release in 1 or 2 seconds. The transmitter will now show a default value close to 4 mA.

In very rare cases, a problem of calibration still may persist. This is because the values of the minimum and maximum are not properly distributed. The RESET function may have to be performed. To RESET the transmitter, simply press Z-DW and S-DW push buttons at the same time, then release the two push buttons after 1 or 2 seconds. Then re-OFFSET the transmitter by pressing Z-UP and S-UP push buttons at the same time. The transmitter will now show a default value close to 4 mA.

NOTE : When you RESET the transmitter, always perform the OFFSET after the RESET function.

DAMPING ADJUST

This feature, primarily designed for agitated tanks and factory set at 0 sec. (max. CW, neg. direction) via a single turn pot, sets a time delay on the output signal. The time delay range is 0-10 sec. approx. For non-agitated tanks a zero setting is fine. Increase the setting for agitated tanks by turning the pot. CCW.

The Damping adjust can also be used as an output filter. In certain applications, such as poorly grounded tanks in electrically noisy environments and/or tanks containing a low dielectric (non-conductive/oil based media), the 4-20mA output, may oscillate. Increase the DAMP ADJ by turning the pot in + direction. (CCW), and observe the output. It should stabilize. Fill the tank as per CALIBRATION PROCEDURES that follow. When adjusting Z or S UP & DW push buttons, turn the DAMP ADJ pot back to minimum condition (CW, neg. direction). This is needed because as

increasing the DAMP ADJ adds a time delay to the output signal, it is difficult to calibrate and obtain the exact calculated mA values corresponding to the level in the tank. When calibration is completed, and if the output still oscillates, increase the DAMP ADJ until output is stable or to the max. CCW condition.

CALIBRATION PROCEDURE L- H

THE ZERO, TANK IN L (LOW) STATE, MUST ALWAYS BE CALIBRATED FIRST.

Turn the DAMP ADJ pot to max CW (neg.) direction.

1. Fill the tank to its L (0 %) level (with probe covered).
2. Depress UP or DW buttons on Z until meter reads 4.00 mA. Do not change the zero controls from now on. If changed, the material will have to be returned to the L (0 %) level.

NOTE : *If a 4.00 mA value cannot be reached, then perform OFFSET AND RESET functions and restart the calibration from step 1.*

3. Fill the tank to the desired H (100 %) level.

NOTE : *The loop current may not rise in proportion to the rising material level in tank. Instead it may rise more rapidly or more slowly than the material level. The SPAN, S-UP or S-DW buttons may be used occasionally to maintain the loop current approximately proportional to the tank filling or just below the 20.00 mA reading.*

4. After the tank has been filled to H (100 %), depress SPAN UP or DW buttons as required to obtain a meter reading of 20.00 mA. If 20.00 mA reading has been obtained, the calibration is complete.

NOTE : *If a 20.00 mA value cannot be reached, then perform OFFSET AND RESET functions and restart the calibration from step 1.*

CALIBRATION PROCEDURE L-H1

THE ZERO, TANK IN L (LOW) STATE, MUST ALWAYS BE CALIBRATED FIRST.

Turn the DAMP ADJ pot to max CW (neg.) direction.

1. Fill the tank to its L (0 %) level (with probe covered).

2. Depress UP or DW buttons on Z until meter reads 4.00 mA. Do not change the zero controls from now on. If changed, the material will have to be returned to the L (0 %) level.

NOTE : *If a 4.00 mA value cannot be reached, then perform OFFSET AND RESET functions and restart the calibration from step 1.*

3. Fill the tank to the highest point possible (under 100 %), and record this level as H1. The most accurate calibration will be obtained with the greatest separation between L and H1.

NOTE : *The loop current may not rise in proportion to the rising material level in tank. Instead it may rise more rapidly or more slowly than the material level. The SPAN, S-UP or S-DW buttons may be used occasionally to maintain the loop current approximately proportional to the tank filling or just below the 20.00 mA reading.*

4. To determine the loop current at H1 level use the following formula :

$$\text{mA} = \frac{(H1 - L)}{(H - L)} \times 16 + 4$$

Example :

- L = 12" (30.5 cm) from the bottom of the tank
H1 = 72" (183 cm) from the bottom of the tank
H = 96" (244 cm) from the bottom of the tank

$$\text{mA} = \frac{(72 - 12)}{(96 - 12)} \times 16 + 4 = 15.43$$

The correct loop current is 15.43 mA.

Depress SPAN S-UP or S-DW buttons as required to obtain a meter reading of 15.43 mA. If 15.43 mA reading has been obtained, the calibration is complete.

NOTE : *If a 15.43 mA (for this example) value cannot be reached, then perform OFFSET AND RESET functions and restart the calibration from step 1.*

CALIBRATION PROCEDURE L1-H1

THE ZERO, TANK IN L1 (LOW) STATE, MUST ALWAYS BE CALIBRATED FIRST.

Turn the DAMP ADJ pot to max CW (neg.) direction.

1. Fill the tank to its L1, some point above 0 % level and record this level as L1. See Fig. 4. To determine the loop current at L1 level use the following formula :

$$\text{mA} = \frac{(L1 - L)}{(H - L)} \times 16 + 4$$

Example :

- L** = 12" (30.5 cm) from the bottom of the tank
- L1** = 24" (61 cm) from the bottom of the tank
- H** = 96" (244 cm) from the bottom of the tank

$$\text{mA} = \frac{(24 - 12)}{(96 - 12)} \times 16 + 4 = 6.28$$

The correct loop current is 6.28mA.

2. Depress Z-UP or Z-DW buttons on ZERO until meter reads 6.28 mA. Do not change the ZERO controls from now on. If changed, the material will have to be returned to the L (0%) level.

NOTE : *If a 6.28 mA (for this example) value cannot be reached, then perform OFFSET AND RESET functions and restart the calibration from step 1.*

3. Fill the tank to the highest point possible (under 100%), and record this level as H1. The most accurate calibration will be obtained with the greatest separation between L and H1.

NOTE : *The loop current may not rise in proportion to the rising material level in tank. Instead it may rise more rapidly or more slowly than the material level. The SPAN, S-UP or S-DW buttons may be used occasionally to maintain the loop current approximately proportional to the tank filling or just below the 20.00 mA reading*

4. To determine the loop current at H1 level use the following formula :

$$\text{mA} = \frac{(H1 - L)}{(H - L)} \times 16 + 4$$

Example :

- L** = 12" (30 cm) from the bottom of the tank
- H1** = 72" (183 cm) from the bottom of the tank
- H** = 96" (244 cm) from the bottom of the tank

$$\text{mA} = \frac{(72 - 12)}{(96 - 12)} \times 16 + 4 = 15.43$$

The correct loop current is 15.43mA.

Depress SPAN S-UP or S-DW buttons as required to obtain a meter reading of 15.43 mA. If 15.43 mA reading has been obtained, the calibration is complete.

NOTE : *If a 15.43 mA (for this example) value cannot be reached, then perform OFFSET AND RESET functions and restart the calibration from step 1.*

Electrical Specifications :	
Power :	12 VDC - 36 VDC
Output :	4 - 20 mA , 2-wire
Maximum Loop Resistance :	350ohm at 12VDC, 950ohm at 24VDC
Calibration :	Via 4 push-buttons
Capacitance range :	10 pF to 10000 pF
Resolution :	±0.1%
Linearity Due to Temperature :	Negligible (less than 100 ppm)
Minimum Span :	10 pF
Accuracy and Repeatability :	±1% of span or less
Output Damping :	One turn pot, 0 - 10 sec. delay
Sensing System :	Capacitance
Maximum Probe Frequency :	1.2 Mhz
Maximum Power at Probe :	8 mW
Operating Temperature :	Electronics -40° to 70°C
Hazardous Areas :	Consult Factory

Mechanical Specifications :	
-----------------------------	--

Fitting or Housing :	NEMA 6X
Process Connection :	1/2" & 3/4" NPT std., others available
Maximum Pressure :	Refer to data sheet for application.
Wetted Materials :	
Fitting :	316 Stainless Steel & Teflon
Probe :	316SS bare or fully Teflon clad

LTX60 CONTINUOUS CAPACITANCE LEVEL WORK ORDER SHEET.

Company Name : _____

Name : _____ Date : _____

Address : _____

Tel. : _____ Fax : _____

City : _____

E-mail : _____

Prov. : _____ Postal Code : _____

Sales Rep. / Distributor Name : _____

Measured Product:

- Liquid Slurry Granular

Mixture Made of : _____ % _____

_____ % _____ , _____ % _____

Dielectric Constant (if known) : _____

Vessel Conditions :

- Heavy Buildup on walls and Probe

- Foam Dust Strong

- Agitation Light None

Temp.: Normal _____ °C, Min. _____ °C, Max.: _____ °C

Pressure : Normal _____ PSI, Min. _____ PSI

Max. _____ PSI

Vessel Type and Construction:

- Carbon Steel Teflon
 Stainless Steel Teflon Lined
 Concrete Rubber Lined
 Other : _____

Accessories Required :

- Analog Meter 3 1/2 Digit Meter
 4 1/2 Digit Meter 2 Setpoint Relay Board
 Controller 4 Setpoint Relay Board
 Other : _____

Probe/Tank Mounting :

- 3/4 NPT (std) Or : _____
 Flange (Size / Rating) : _____
 Sanitary (Size / Cap) : _____

Probe, L : _____ (in / ft) Tank, H : _____ (in / ft)

D : _____ d : _____ x : _____ cs : _____ c : 0.50" _____

Note : Use the grid at the bottom of this page to sketch the vessel with accurate dimensions. d, x, cs, c, not essential but enter if known. "A" specified by Factory.

Power Supply : 12-36V DC (only)

Area Classification : _____

