



OPTIWAVE 5400 C Technical Datasheet

24 GHz Radar (FMCW) Level Transmitter for liquids in basic process applications

- Market-entry transmitter
- Proven PP Drop antenna design insensitive to condensation



1 Product features	3
1.1 The FMCW radar level transmitter for liquids in basic process applications.....	3
1.2 Applications	4
1.3 Product family	5
1.4 Measuring principle.....	9
2 Technical data	11
2.1 Technical data.....	11
2.2 Measuring accuracy	18
2.3 Minimum power supply voltage	19
2.4 Guidelines for maximum operating pressure.....	20
2.5 Dimensions and weights	22
3 Installation	35
3.1 Intended use	35
3.2 Pre-installation requirements	35
3.3 Installation	36
3.3.1 Pressure and temperature ranges.....	36
3.3.2 Recommended mounting position.....	36
3.3.3 Mounting restrictions.....	38
3.3.4 Process connections.....	40
3.3.5 LPR devices: recommendations for pits and tanks made of non-conductive materials	42
3.3.6 Standpipes (stilling wells and bypass chambers)	43
4 Electrical connections	47
4.1 Electrical installation: output options with cable gland	47
4.2 Electrical installation: output options with an M12 male connector.....	47
4.3 Non-Ex devices	48
4.4 Devices for hazardous locations	48
4.5 Networks	49
4.5.1 General information.....	49
4.5.2 Point-to-point connection.....	49
4.5.3 Multi-drop networks	50
5 Notes	51

1.1 The FMCW radar level transmitter for liquids in basic process applications

This device is a non-contact radar level transmitter that uses FMCW technology. It measures distance, level and volume of liquids and pastes. It is a market-entry transmitter that provides accurate readings in closed tanks, in the open air like rivers or dams, and even in fast moving processes.

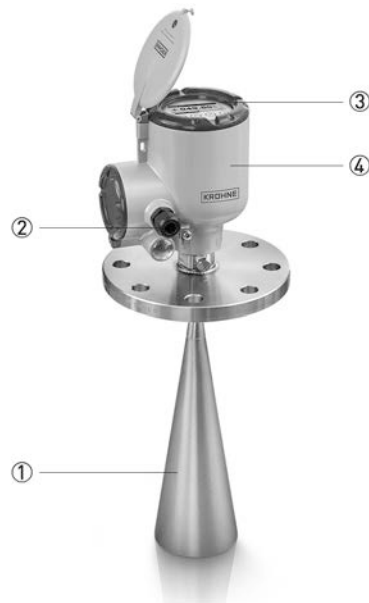

- ① A large choice of Metallic Horn and Drop antennas. The PP Drop antenna has a small beam angle and is ideal for condensing and corrosive applications.
- ② 2-wire 24 GHz FMCW radar level transmitter
- ③ Large, backlit LCD screen with 4-button keypad can be used with a bar magnet without opening the housing cover. The software has a quick-setup assistant for easy commissioning. 12 languages are available.
- ④ Aluminium or stainless-steel housing

Highlights

- KROHNE is the pioneer of FMCW radar level measurement and has more than 30 years of experience with this technology
- Accuracy ± 2 mm / ± 0.08 "
- 2-wire loop-powered 24 GHz transmitter – HART® 7
- Small beam angle (5° with DN150 / 6" PP Drop antenna)
- Flange plate protection and proven Drop antennas made of PP for condensing and corrosive applications
- Ellipsoidal shape and smooth surface of the Drop antenna minimizes scaling
- Extensive choice of process connections (threaded ≥ 1 " and flange \geq DN40)
- DN200 / 8" Metallic Horn antenna for measuring distances up to 100 m / 328 ft
- Antenna extensions to suit any nozzle length
- Process conditions up to +130°C / +266°F at 16 barg / 232 psig
- Empty tank spectrum function eliminates false reflections caused by tank internals
- Intuitive installation wizard for quick on-site set-up

Industries

- Chemical market
- Oil & Gas
- Petrochemicals
- Power
- Steel

Applications

- Storage and process tanks where high accuracy ± 2 mm / 0.08" is specified
- Long measuring range applications
- Measurement of liquids in open air as well as closed tanks

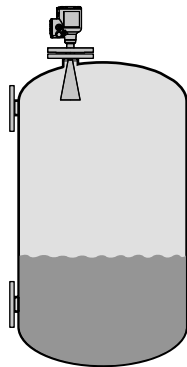
1.2 Applications**1. Level measurement of liquids**

The level transmitter can measure the level of a wide range of liquid products on a large variety of installations within the stated pressure and temperature range. It does not require any calibration: it is only necessary to do a short configuration procedure.

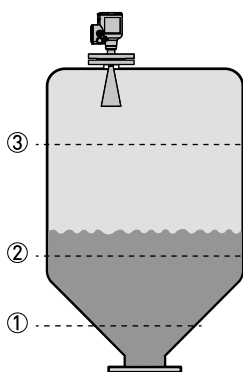
2. Volume (mass) measurement

A strapping table function is available in the configuration menu for volume or mass measurement. Up to 50 volume (mass) values can be related to level values. For example:

Level ① = 2 m / Volume ① = e.g. 0.7 m³

Level ② = 10 m / Volume ② = e.g. 5 m³

Level ③ = 20 m / Volume ③ = e.g. 17 m³

This data permits the device to calculate (by linear interpolation) volume or mass between strapping table entries.

PACTware™ software and a DTM (Device Type Manager) is supplied free of charge with the device. This software permits the user to easily configure the device with a computer. It has a conversion table function with a large number of tank shapes.

1.3 Product family

OPTIWAVE 5200 C/F (10 GHz) for liquids in storage and process applications



This 10 GHz 2-wire FMCW radar level transmitter measures distance, level, volume, mass and flow rate of liquids and pastes. It is ideal for corrosive products with its PP or PTFE antenna options. It features unique PP and PTFE antennas for aggressive products. The device is able to measure distances up to 30 m / 98.4 ft in process conditions up to +250°C / +482°F and 40 barg / 580 psig.

The device agrees with SIL2 requirements for safety-related systems (as per IEC 61508). Output options include HART®, FOUNDATION™ fieldbus and PROFIBUS PA industrial communication protocols.

OPTIWAVE 5400 C (24 GHz) for liquids in basic process applications



Designed for basic liquid applications, this market entry 24 GHz 2-wire FMCW radar transmitter provides accurate readings even in fast moving processes, in closed tanks or in the open air like rivers or dams. Its proven PP Drop antenna is insensitive to condensation.

The OPTIWAVE 5400 can measure in process conditions with temperatures up to +130°C / +266°F and pressures up to 16 barg / 232 psig. The antenna options permit to measure distances up to 100 m / 328 ft. The device can be installed in high nozzles (≤ 1 m / 3.28 ft) when it is fitted with antenna extensions.

OPTIWAVE 7400 C (24 GHz) for agitated and corrosive liquids



This 24 GHz FMCW radar level transmitter is designed for liquids in harsh environment like tanks with agitators containing corrosives or in non-Ex applications with extremely high process temperatures, like molten salt in solar plants (+700°C / +1292°F). For toxic and dangerous products, the use of a Metaglas® second sealing barrier is recommended.

The PTFE and PEEK Drop antennas have optional flange plate protection for corrosive media. Heating and cooling systems prevent from crystallization inside the Metallic Horn antennas. The device measures distances up to 100 m / 328 ft and can be installed in high nozzles (≤ 1 m / 3.28 ft) when fitted with antenna extensions. Standard process conditions up to +200°C / 392°F; 100 barg / 1450 psig (higher on request).

OPTIWAVE 7500 C (80 GHz) for liquids in narrow tanks with internal obstructions



The small beam angle and negligible dead zone of this 80 GHz FMCW radar level transmitter makes it the premium choice for liquids in small and narrow tanks with internal obstructions like agitators or heating coils, as well as tanks with long nozzles. It can even measure through tank roofs made of non-conductive material (e.g. plastic, fiberglass or glass). The flush-mounted PEEK Lens antenna (no tank intrusion) is insensitive to deposit.

There is an extensive choice of process connections starting from 3/4". Flanges have an optional PEEK plate protection for corrosive tank contents. The OPTIWAVE 7500 operates in process conditions with temperatures up to +150°C / +302°F and pressures up to 40 barg / 580 psig. It measures distances up to 100 m / 328 ft and a 112 mm / 4.4" extension is available for high nozzles.

OPTIWAVE 3500 C (80 GHz) for liquids with hygienic requirements



This 80 GHz FMCW radar transmitter for hygienic liquid applications in the pharmaceutical, food and beverage industries is CIP-SIP suitable and offers a large choice of hygienic process connections: Tri-Clamp®, Tuchenhagen VARIVENT®, SMS, DIN 11851, DIN 11864-1 Form A, NEUMO BioControl®.

The small dead zone and beam angle of its flush-mounted Lens antenna enables precise measurement even in small and narrow tanks with agitators. The OPTIWAVE 3500 measures up to 50 m / 164 ft in process conditions up to +150°C / +302°F and 25 barg / 363 psig.

OPTIWAVE 6400 C (24 GHz) for solids from granulates to rocks



By combining high signal dynamics and FMCW radar technology, this market-entry 24 GHz radar device measures accurately and reliably the level of solids like stone, plastic granulates or coffee beans. No need for expensive antenna aiming kits or purging systems; the proven Drop antenna design minimizes scaling and is not affected by the angle of repose.

It operates in process conditions with temperatures up to +130°C / +266°F and pressures up to 16 barg / 232 psig. The antenna options permit the device to measure distances up to 100 m / 328 ft.

OPTIWAVE 6500 C (80 GHz) for powders and dusty atmosphere



Accurate continuous level measurement of fine powders has to deal with a series of issues like dust, low-reflective media, build-up and uneven surfaces. The specific algorithms and high signal dynamics of this 80 GHz FMCW radar transmitter are the key to provide reliable and accurate readings despite these difficult conditions. Thanks to the small beam angle of the flush-mounted Lens antenna, this powerful device handles high and narrow silos even in the presence of internal obstructions.

The OPTIWAVE 6500 operates in process conditions with temperatures up to +200°C / +392°F and pressures up to 40 barg / 580 psig. It offers an extensive choice of threaded ($\geq 1\frac{1}{2}$ ") and flanged ($\geq \text{DN}50 / 2$ ") process connections. The antenna options permit the device to measure distances up to 100 m / 328 ft. A 112 mm / 4.4" extension is available for high nozzles.

1.4 Measuring principle

A radar signal is emitted via an antenna, reflected from the product surface and received after a time t . The radar principle used is FMCW (Frequency Modulated Continuous Wave).

The FMCW-radar transmits a high frequency signal whose frequency increases linearly during the measurement phase (called the frequency sweep). The signal is emitted, reflected on the measuring surface and received with a time delay, t . Delay time, $t=2d/c$, where d is the distance to the product surface and c is the speed of light in the gas above the product.

For further signal processing the difference Δf is calculated from the actual transmitted frequency and the received frequency. The difference is directly proportional to the distance. A large frequency difference corresponds to a large distance and vice versa. The frequency difference Δf is transformed via a Fast Fourier Transform (FFT) into a frequency spectrum and then the distance is calculated from the spectrum. The level results from the difference between the tank height and the measured distance.

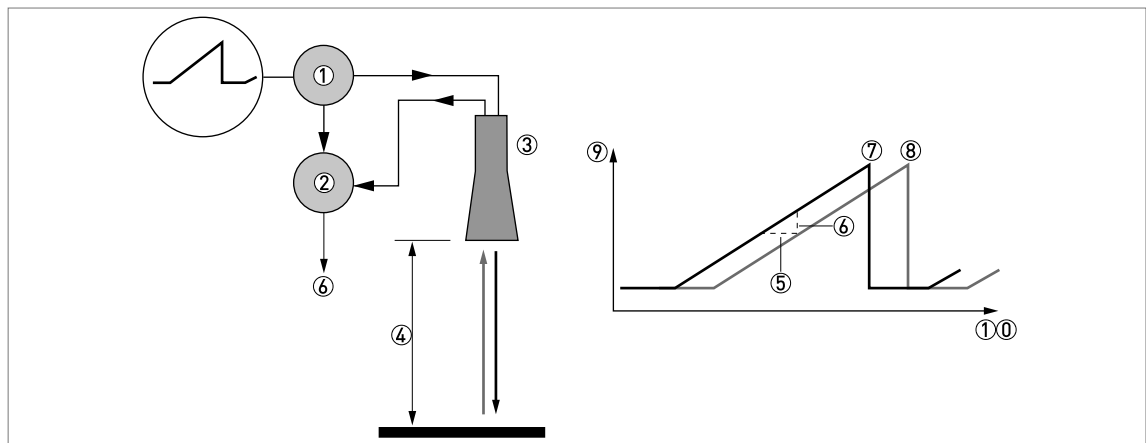

Figure 1-1: Measuring principle of FMCW radar

- ① Transmitter
- ② Mixer
- ③ Antenna
- ④ Distance to product surface, where change in frequency is proportional to distance
- ⑤ Differential time delay, Δt
- ⑥ Differential frequency, Δf
- ⑦ Frequency transmitted
- ⑧ Frequency received
- ⑨ Frequency
- ⑩ Time

Measurement modes

"Direct" mode

If the dielectric constant of the liquid is high ($\epsilon_r \geq 1.4$), the level signal is the reflection on the surface of the liquid.

"TBF Auto" mode

If the dielectric constant of the liquid is low (ϵ_r 1.4...1.5, for long-distance measurement), you must use "TBF Auto" mode to measure level correctly. "TBF Auto" is an automatic mode that lets the device make a selection between "Direct" mode and "TBF" mode. If the device finds a large radar reflection above the "tank bottom area" (the bottom 20% of the tank height), the device will use "Direct" mode. If the device finds a large radar reflection in the "tank bottom area", the device uses TBF mode. This mode can be used only in tanks with flat bottoms or in stilling wells with a reference plate at the bottom.

"Full TBF" mode

TBF = Tank Bottom Following. If the dielectric constant of the liquid is very low ($\epsilon_r < 1.4$), you must use "TBF Full" mode to measure level correctly. The device uses the radar reflection on the bottom of the tank (the signal goes through the liquid). This mode can be used only in tanks with flat bottoms or in stilling wells with a reference plate at the bottom.

2.1 Technical data

- *The following data is provided for general applications. If you require data that is more relevant to your specific application, please contact us or your local sales office.*
- *Additional information (certificates, special tools, software,...) and complete product documentation can be downloaded free of charge from the website (Downloadcenter).*

Measuring system

Measuring principle	2-wire loop-powered level transmitter; FMCW radar
Frequency range	K-band (24...26 GHz)
Max. radiated power (EIRP)	< -41.3 dBm according to ETSI EN 302 372 (TLPR) and ETSI EN 302 729 (LPR)
Application range	Level measurement of liquids, pastes and slurries
Primary measured value	Distance and reflection
Secondary measured value	Level, volume and mass

Design

Construction	The measurement system consists of a measuring sensor (antenna) and a signal converter
Options	Integrated LCD display (-20...+70°C / -4...+158°F); if the ambient temperature is not in these limits, then this condition can stop the display
	Straight antenna extensions (length 105 mm / 4.1") Max. extension length, Metallic Horn antenna: 1050 mm / 41.3" Max. extension length, Drop antenna: 525 mm / 20.7"
	Antenna purging system for Metallic Horn antennas (supplied with a 1/8 - 27 NPTF connection)
	PP flange plate protection and extension protection (PP protective layer for antenna extensions)
	Weather protection
Max. measuring range (antenna)	Metallic Horn, DN40 (1½"): 15 m / 49.2 ft
	Metallic Horn, DN50 (2"): 20 m / 65.6 ft
	Metallic Horn, DN65 (2½"): 25 m / 82 ft – for the BM 26 A magnetic level indicator
	Metallic Horn, DN80 (3"): 50 m / 164 ft
	Metallic Horn, DN100 (4"): 80 m / 262.5 ft
	Metallic Horn, DN150 (6") and DN200 (8"): 100 m / 328.1 ft
	PP Drop, DN80 (3"): 50 m / 164 ft
	PP Drop, DN100 (4"): 80 m / 262.5 ft
	PP Drop, DN150 (6"): 100 m / 328.1 ft
	Refer also to "Measuring accuracy" on page 18
Min. tank height	0.2 m / 8"
Recommended minimum blocking distance	Antenna extension length + antenna length + 0.1 m / 4"
Min. distance for reflection measurement	1 m / 3.3 ft

Beam angle (antenna)	Metallic Horn, DN40 (1½"): 17°
	Metallic Horn, DN50 (2"): 16°
	Metallic Horn, DN65 (2½"): not applicable. This antenna option is for the BM 26 A magnetic level indicator.
	Metallic Horn, DN80 (3"): 9°
	Metallic Horn, DN100 (4"): 8°
	Metallic Horn, DN150 (6"): 6°
	Metallic Horn, DN200 (8"): 5°
	PP Drop, DN80 (3"): 9°
	PP Drop, DN100 (4"): 7°
	PP Drop, DN150 (6"): 5°
Display and user interface	
Display	Backlit LCD display
	128 × 64 pixels in 64-step greyscale with 4-button keypad
Interface languages	English, French, German, Italian, Spanish, Portuguese, Chinese (simplified), Japanese, Russian, Czech, Polish and Turkish

Measuring accuracy

Resolution	1 mm / 0.04"
Repeatability	±1 mm / ±0.04"
Accuracy	±2 mm / ±0.08", when distance ≤ 10 m / 33 ft
	±0.02% of measured distance, when distance > 10 m / 33 ft. For more data, refer to the "Measuring accuracy" section in this chapter. If the maximum measuring range is more than 60 m / 197 ft, we recommend that the device has a calibration certificate option.
Reference conditions acc. to EN 61298-1	
Temperature	+15...+25°C / +59...+77°F
Pressure	1013 mbara ±50 mbar / 14.69 psia ±0.73 psi
Relative air humidity	60% ±15%
Target	Metal plate in an anechoic chamber

Operating conditions

Temperature	
Ambient temperature	-40...+80°C / -40...+176°F Ex: see supplementary operating instructions or approval certificates
Relative humidity	0...99%
Storage temperature	-40...+85°C / -40...+185°F
Process connection temperature (higher temperature on request)	Metallic Horn antenna: -50...+130°C / -58...+266°F (the process connection temperature must agree with the temperature limits of the gasket material. Refer to "Materials" in this table.) Ex: see supplementary operating instructions or approval certificates
	Drop antenna (PP): -40...+100°C / -40...+212°F (the process connection temperature must agree with the temperature limits of the gasket material. Refer to "Materials" in this table.) Ex: see supplementary operating instructions or approval certificates

Pressure	
Process pressure	Drop antenna (PP): -1...16 barg / -14.5...232 psig
	Metallic Horn antenna: -1...16 barg / -14.5...232 psig
	Subject to the process connection used and the process connection temperature. For more data, refer to <i>Guidelines for maximum operating pressure</i> on page 20.
Other conditions	
Dielectric constant (ϵ_r)	Direct mode: ≥ 1.4 TBF mode: ≥ 1.1
Ingress protection	IEC 60529: IP66 / IP68 (0.1 barg / 1.45 psig)
	NEMA 250: NEMA type 4X - 6 (housing) and type 6P (antenna)
Maximum rate of change	60 m/min / 196 ft/min

Installation conditions

Process connection size	The nominal diameter (DN) should be equal to or larger than the antenna diameter.
	If the nominal diameter (DN) is smaller than the antenna, either: – provide the means to adapt the device to a larger process connection on the tank (for example, a plate with a slot), or – use the same process connection, but remove the antenna from the device before installation and fit it from inside the tank.
Process connection position	Make sure that there are not any obstructions directly below the process connection for the device. For more data, refer to <i>Installation</i> on page 35.
Dimensions and weights	For dimensions and weights data, refer to <i>Dimensions and weights</i> on page 22.

Materials

Housing	Standard: Polyester-coated aluminium
	Option: Stainless steel (1.4404 / 316L)
Wetted parts, including antenna	Metallic Horn antenna: Stainless steel (1.4404 / 316L)
	Standard for Drop antenna: PP
	Option for Drop antenna: PP flange plate protection and PP protective layer for antenna extensions
Process connection	Stainless steel (1.4404 / 316L) – a PP flange plate protection option is also available for the Drop antenna
Gaskets (and O-rings for the sealed antenna extension option)	PP Drop antenna: FKM/FPM (-40...+100°C / -40...+212°F); Kalrez® 6375 (-20...+100°C / -4...+212°F); EPDM (-40°C...+100°C / -40...+212°F)
	Metallic Horn antenna: FKM/FPM (-40...+130°C / -40...+266°F); Kalrez® 6375 (-20...+130°C / -4...+266°F); EPDM (-50°C...+130°C / -58...+266°F)
Feedthrough	PEI (-50...+130°C / -58...+266°F) This is the maximum range. The feedthrough temperature limits must agree with the temperature limits of the gasket material and antenna type.
Cable gland	Standard: none
	Options: Plastic (Non-Ex: black, Ex i-approved: blue); nickel-plated brass; stainless steel; M12 (4-pin connector)
Weather protection (Option)	Stainless steel (1.4404 / 316L)

Process connections

Thread	G 1 A...1 1/2 A (ISO 228); 1 - 11.5...1 1/2 - 11.5 NPT (ASME B1.20.1)
Flange version	
EN 1092-1	Low-pressure flanges: DN50...200 in PN01; Standard flanges: DN40 in PN40, DN50...200 in PN16 and PN40 (Type B1); others on request Optional flange facing for standard flanges: Type A
ASME B16.5	Low-pressure flanges: NPS 2...8 in Class 150 (max. 15 psig); Standard flanges: NPS 1 1/2...8 in Class 150 RF and Class 300 RF; others on request Optional flange facing for standard flanges: FF (Flat Face) ①
JIS B2220	40...200A in 10K RF; others on request
Other	Others on request

Electrical connections

Power supply	Terminals output – Non-Ex / Ex i: 12...30 V DC; min./max. value for a maximum output of 21.5 mA at the terminals
	Terminals output – Ex d: 16...36 V DC; min./max. value for a maximum output of 21.5 mA at the terminals
Maximum current	21.5 mA
Current output load	Non-Ex / Ex i: $R_L [\Omega] \leq ((U_{ext} - 12 V)/21.5 \text{ mA})$. For more data, refer to <i>Minimum power supply voltage</i> on page 19.
	Ex d: $R_L [\Omega] \leq ((U_{ext} - 16 V)/21.5 \text{ mA})$. For more data, refer to <i>Minimum power supply voltage</i> on page 19.
Cable entry	Standard: M20×1.5; Options: 1/2 - 14 NPT; 4-pin male M12 connector
Cable gland	Standard: none
	Options: M20×1.5 (cable diameter: 7...12 mm / 0.28...0.47"); others are available on request
Cable entry capacity (terminal)	0.5...3.31 mm ² (AWG 20...12)

Input and output

Current output	
Output signal	Standard: 4...20 mA
	Options: 3.8...20.5 mA acc. to NAMUR NE 43; 4...20 mA (reversed); 3.8...20.5 mA (reversed) acc. to NAMUR NE 43
Output type	Passive
Resolution	±1 µA
Temperature drift	Typically 50 ppm/K
Error signal	High: 21.5 mA; Low: 3.5 mA acc. to NAMUR NE 43
HART®	
Description	Digital signal transmitted with the current output signal (HART® protocol)
Version	7.4
Load	≥ 250 Ω
Digital temperature drift	Max. ±15 mm / 0.6" for the full temperature range
Multi-drop operation	Yes. Current output = 4 mA. Enter Program mode to change the polling address (1...63).
Available drivers	FC475, AMS, PDM, FDT/DTM

PROFIBUS PA	
Type	PROFIBUS MBP interface that agrees with IEC 61158-2 with 31.25 kbit/s; voltage mode (MBP = Manchester-Coded, Bus-Powered)
Function blocks	1 × Transducer Block Level (TB-Level), 1 × Physical Block (PB), 4 × Analog Input Block (AI), 1 × Totalizer Function Block (TOT)
Device power supply	9...32 V DC – bus powered; no additional power supply required
Polarity sensitivity	No
Basic current	18 mA
FOUNDATION™ fieldbus	
Physical layer	FOUNDATION™ fieldbus protocol that agrees with IEC 61158-2 and FISCO model; galvanically isolated
Communication standard	H1
ITK version	6.3
Function blocks	1 × Enhanced Resource Block (RB), 1 × Customer Level Transducer Block (LEVELTB), 1 × Customer Converter Transducer Block (CONVTB), 1 × Customer Diagnosis Transducer Block (DIAGTB), 4 × Analog Input Block (AI), 1 × Digital Input (DI), 1 × Integrator Block (IT), 1 × Proportional Integral Derivate Block (PID), 1 × Arithmetic Block (AR)
	Analog Input Block: 10 ms
	Digital Input Block: 20 ms
	Integrator Block: 15 ms
	Proportional Integral Derivate Block: 25 ms
Device power supply	Not intrinsically safe: 9...32 V DC Intrinsically safe: 9...24 V DC
Basic current	18 mA
Maximum error current FDE	25.5 mA (= basic current + error current = 18 mA + 7.5 mA)
Polarity sensitivity	No
Minimum cycle time	250 ms
Output data	Level, distance, volume, ullage volume, mass, ullage mass
Input data	None
Link Active Scheduler	Supported
NAMUR NE 107 data	Supported with FF field diagnosis (FF-891)

Approvals and certification

CE / UKCA	The device meets the essential requirements of the EU Directives and UK Regulations. The manufacturer certifies successful testing of the product by applying the CE or UKCA marking. For more data about the European Standards and UK Designated Standards related to this device, refer to the EU and the UKCA Declarations of Conformity. You can download these documents free of charge from the website (Download Center).
Vibration resistance	EN 60721-4-4 (class 4M4 / 5...8.5 Hz: ±3.5 mm / 8.5...200 Hz: 1g, 15g shock ½ sinus: 6ms); EN 61298-3 (10... 58 Hz: ±0.15 mm / 58...1000 Hz: 2g)
Explosion protection	
ATEX (EU Type Approval)	II 1/2 G Ex ia IIC T6...T* Ga/Gb; ②
	II 1/2 D Ex ia IIIC T85°C...T**°C Da/Db; ③
	II 1/2 G Ex db ia IIC T6...T* Ga/Gb; ②
	II 1/2 D Ex ia tb IIIC T85°C...T**°C Da/Db ③
ATEX (Type Approval)	II 3 G Ex ic IIC T6...T* Gc; ②
	II 3 D Ex ic IIIC T85°C...T**°C Dc ③

IECEX	Ex ia IIC T6...T* Ga/Gb; ②
	Ex ia IIIC T85°C...T**°C Da/Db; ③
	Ex db ia IIC T6...T* Ga/Gb; ②
	Ex ia tb IIIC T85°C...T**°C Da/Db; ③
	Ex ic IIC T6...T* Gc; ②
	Ex ic IIIC T85°C...T**°C Dc ③
UKEX - pending	II 1/2 G Ex ia IIC T6...T* Ga/Gb; ②
	II 1/2 D Ex ia IIIC T85°C...T**°C Da/Db; ③
	II 1/2 G Ex db ia IIC T6...T* Ga/Gb; ②
	II 1/2 D Ex ia tb IIIC T85°C...T**°C Da/Db ③
cQPSus	Division ratings
	XP-IS, Class I, Div 1, GPS ABCD, T6...T*; ②
	DIP, Class II/III, Div 1, GPS EFG, T85°C...T**°C; ③
	IS, Class I, Div 1, GPS ABCD, T6...T*; ②
	IS, Class II/III, Div 1, GPS EFG, T85°C...T**°C; ③
	NI, Class I, Div 2, GPS ABCD, T6...T*; ②
	NI, Class II/III, Div 2, GPS FG, T85°C...T**°C ③
	Zone ratings
	Class I, Zone 1, AEx db ia [ia Ga] IIC T6...T* Gb (US) – antenna suitable for Zone 0; Ex db ia [ia Ga] IIC T6...T* Gb (Canada) – antenna suitable for Zone 0; ②
	Class I, Zone 0, AEx ia IIC T6...T* Ga (US); Ex ia IIC T6...T* Ga (Canada); ②
	Zone 20, AEx ia IIIC T85°C...T**°C Da (US); Ex ia IIIC T85°C...T**°C Da (Canada); ③
	Zone 21, AEx ia tb [ia Da] IIIC T85°C...T**°C Db (US) – antenna suitable for Zone 20 Ex ia tb [ia Da] IIIC T85°C...T**°C Db (Canada) – antenna suitable for Zone 20 ③
NEPSI	Ex ia IIC T*...T6 Ga/Gb; ②
	Ex db ia IIC T*...T6 Ga/Gb; ②
	Ex ia IIIC T85°C...T**°C Da / Ex ia IIIC T85°C...T**°C Db; ③
	Ex ia tb IIIC T85°C...T**°C Db ③
EAC-EX	Ga/Gb Ex ia IIC T6...T* X; ②
	Da/Db Ex ia IIIC T85°C...T**°C X; ③
	Ga/Gb Ex db ia IIC T6...T* X; ②
	Da/Db Ex ia tb IIIC T85°C...T**°C X ③
Other standards and approvals	
SIL	SIL2/3 (SIL3: 1oo2 architecture is necessary for homogeneous redundancy) – certified according to all the requirements in EN 61508 (Full Assessment) and for high/low continuous demand mode operation. HFT=0, SFF=94.21% (for non-Ex / Ex i devices) or 94.50% (for Ex d devices), type B device
Electromagnetic compatibility	EU Electromagnetic Compatibility Directive (EMC) SIL2-approved devices agree with EN 61326-3-1 and EN 61326-3-2
	UK Electromagnetic Compatibility Regulations
Radio approvals	EU Radio Equipment Directive (RED)
	UK Radio Equipment Regulations (RER)
	US: FCC Rules Part 15
	Industry Canada RSS-211

Electrical safety	EU: Agrees with the safety part of the EU Low Voltage Directive (LVD)
	UK: Agrees with the safety part of the UK Electrical Equipment (Safety) Regulations
	USA and Canada: Agrees with NEC and CEC requirements for installation in ordinary locations
NAMUR	NAMUR NE 21 Electromagnetic Compatibility (EMC) of Industrial Process and Laboratory Control Equipment
	NAMUR NE 43 Standardization of the Signal Level for the Failure Information of Digital Transmitters
	NAMUR NE 53 Software and Hardware of Field Devices and Signal Processing Devices with Digital Electronics
	NAMUR NE 107 Self-Monitoring and Diagnosis of Field Devices
CRN	This certification is applicable for all Canadian provinces and territories. For more data, refer to the website.
Construction code	Option: NACE MR 0175 / MR 0103 / ISO 15156; ASME B31.3

Table 2-1: Technical data

- ① NPS = Nominal Pipe Size. For more data about the dimensions of ASME flanges, refer to the ASME B16.5 standard.
 ② T* = T5 or T4. For more data, refer to the related Ex approval certificate.
 ③ T** = 100 or 130. For more data, refer to the related Ex approval certificate.

Process connection options: flange facing finish

Type (flange facing)	Flange facing finish, R_a (min...max)	
	[$\mu\text{m Rz}$]	[$\mu\text{in - AARH}$]

EN 1092-1

B1	3.2...12.5	125...500
----	------------	-----------

ASME B16.5

RF or FF	3.2...6.3	125...250
----------	-----------	-----------

JIS B2220

RF	3.2...6.3	125...250
----	-----------	-----------

Table 2-2: Process connection options: flange facing finish

2.2 Measuring accuracy

Use these graphs to find the measuring accuracy for a given distance from the transmitter.

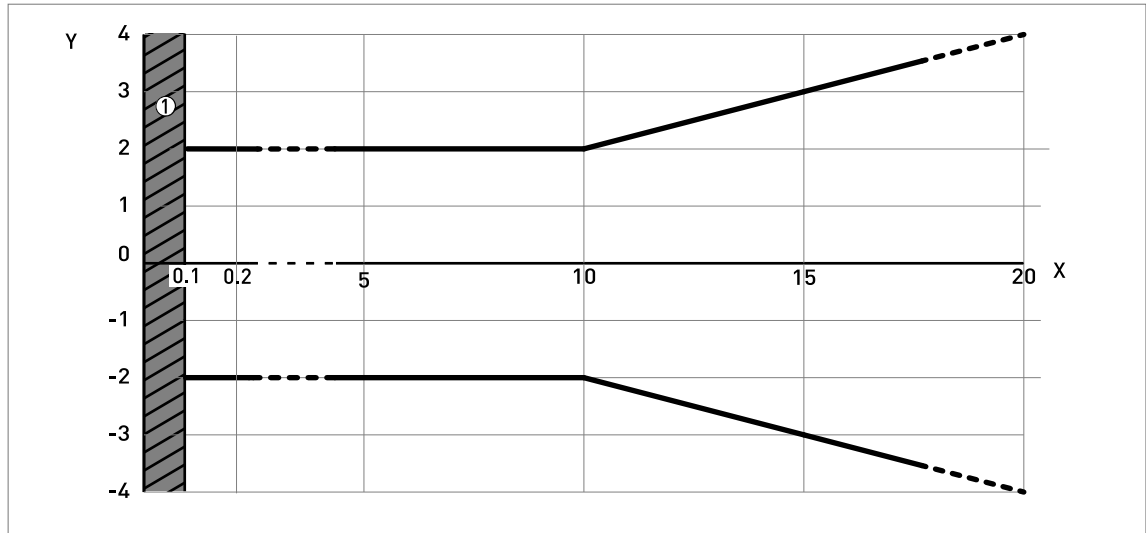

Figure 2-1: Measuring accuracy (graph of measuring accuracy in mm against measuring distance in m)

X: Measuring distance from the thread stop or flange facing of the process connection [m]

Y: Measuring accuracy [+yy mm / -yy mm]

① Minimum recommended blocking distance = antenna extension length + antenna length + 100 mm

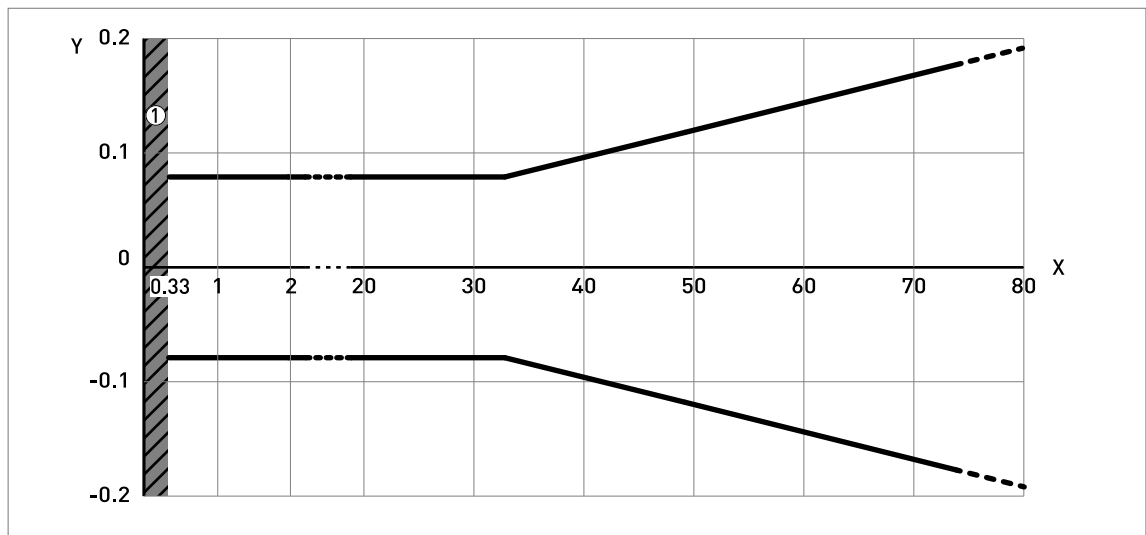

Figure 2-2: Measuring accuracy (graph of measuring accuracy in inches against measuring distance in ft)

X: Measuring distance from the thread stop or flange facing of the process connection [ft]

Y: Measuring accuracy [+yy inches / -yy inches]

① Minimum recommended blocking distance = antenna extension length + antenna length + 3.94"

To calculate the accuracy at a given distance from the antenna, refer to Technical data on page 11 (measuring accuracy).

2.3 Minimum power supply voltage

Use these graphs to find the minimum power supply voltage for a given current output load.

Non-Ex and Hazardous Location approved (Ex i / IS) devices



Figure 2-3: Minimum power supply voltage for an output of 21.5 mA at the terminals (Non-Ex and Hazardous Location approval (Ex i / IS))

X: Power supply U [V DC]

Y: Current output load R_L [Ω]

Hazardous Location (Ex d / XP/NI) approved devices



Figure 2-4: Minimum power supply voltage for an output of 21.5 mA at the terminals (Hazardous Location approval (Ex d / XP/NI))

X: Power supply U [V DC]

Y: Current output load R_L [Ω]

2.4 Guidelines for maximum operating pressure

Make sure that the devices are used within their operating limits.

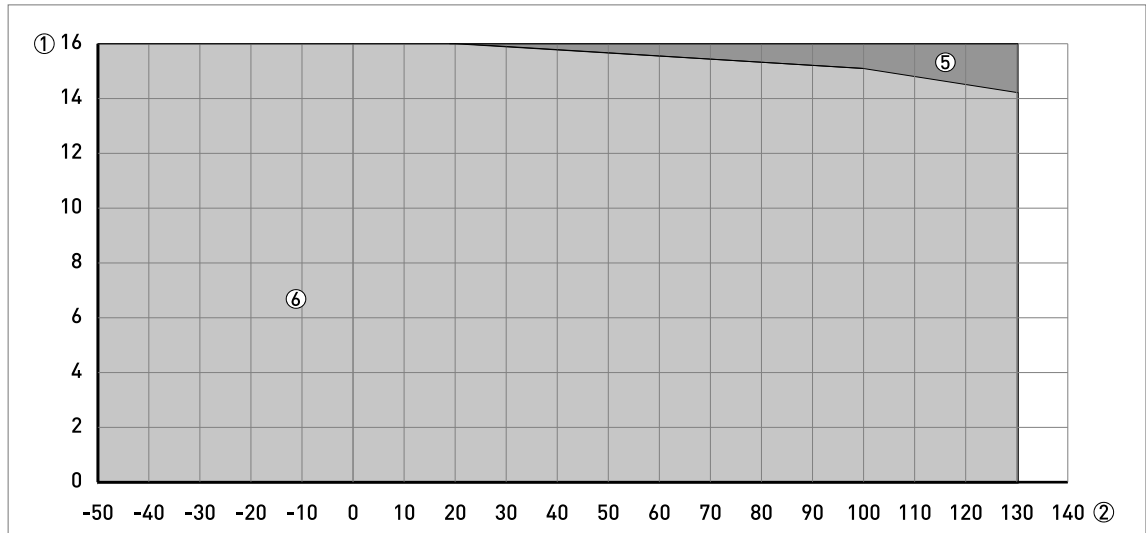

Figure 2-5: Pressure / temperature de-rating (EN 1092-1), flange and threaded connection, in °C and barg

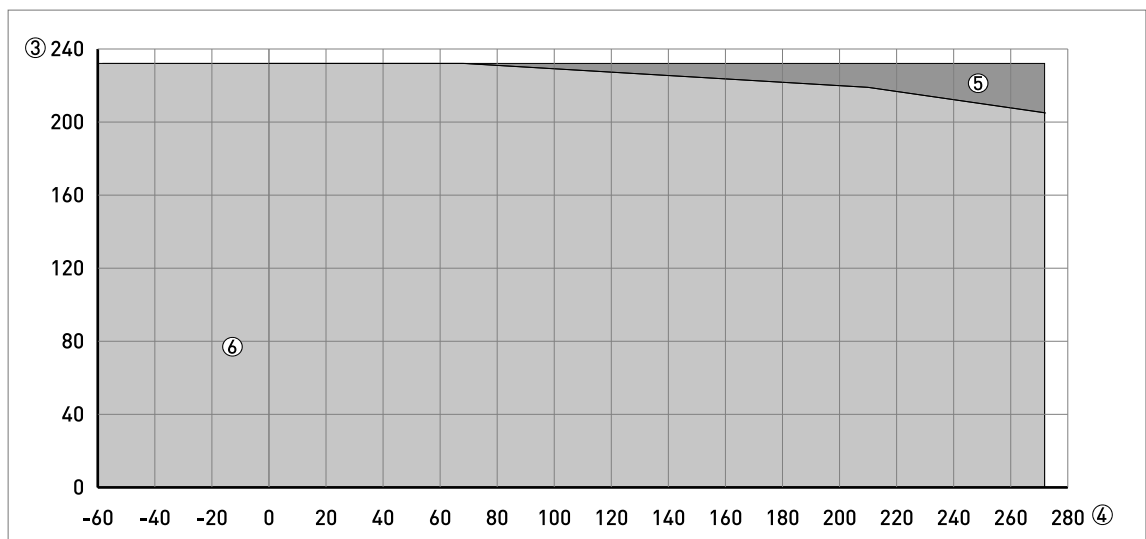

Figure 2-6: Pressure / temperature de-rating (EN 1092-1), flange and threaded connections, in °F and psig

- ① Process pressure, p [barg]
- ② Process connection temperature, T [°C]
- ③ Process pressure, p [psig]
- ④ Process connection temperature, T [°F]
- ⑤ Threaded connection, G (ISO 228-1). Flange connection, PN40.
- ⑥ Flange connection, PN16

CRN certification

There is a CRN certification option for devices with process connections that agree with ASME standards. This certification is necessary for all devices that are installed on a pressure vessel and used in Canada.

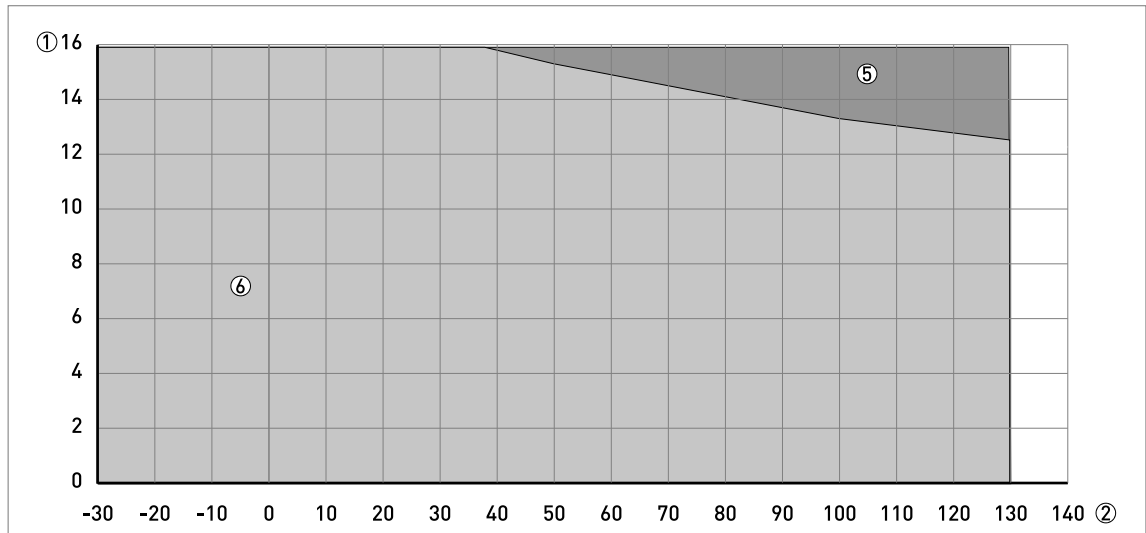

Figure 2-7: Pressure / temperature de-rating (ASME B16.5), flange and threaded connections, in °C and barg

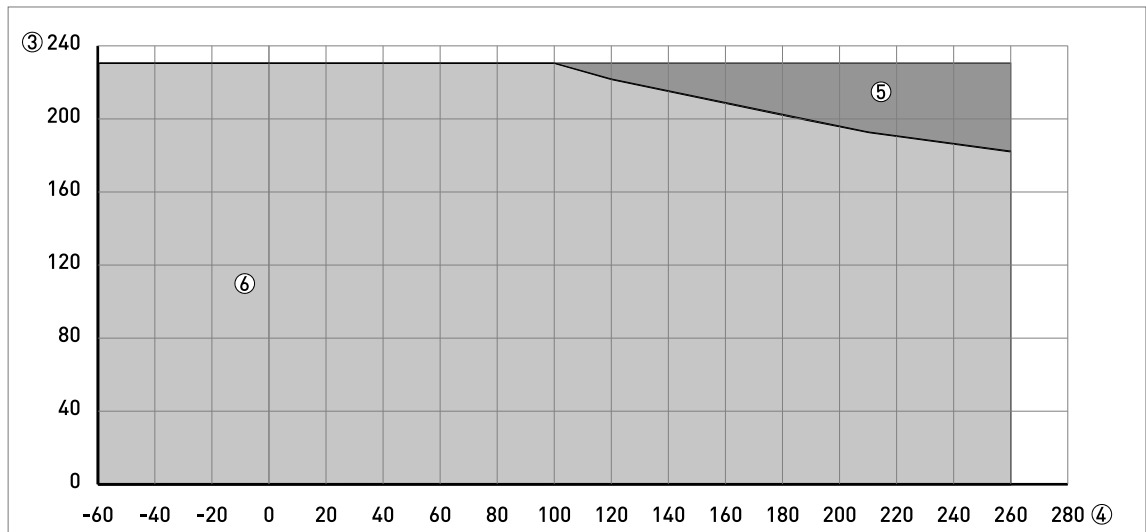

Figure 2-8: Pressure / temperature de-rating (ASME B16.5), flange and threaded connections, in °F and psig

- ① Process pressure, p [barg]
- ② Process connection temperature, T [°C]
- ③ Process pressure, p [psig]
- ④ Process connection temperature, T [°F]
- ⑤ Threaded connection, NPT (ASME B1.20.1). Flange connection, Class 300.
- ⑥ Flange connection, Class 150

2.5 Dimensions and weights

Metallic Horn antennas with threaded connections

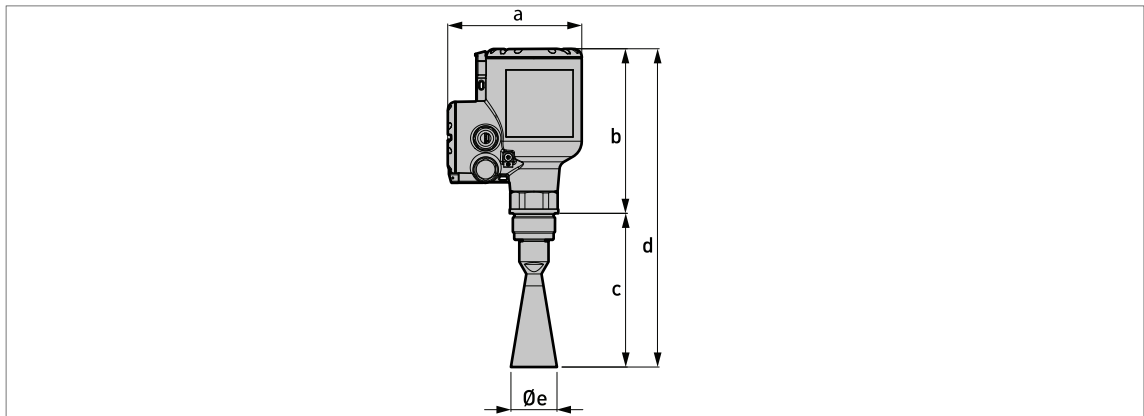

Figure 2-9: Metallic Horn antennas with G or NPT threaded connections

- *The diameter of the outer sheath of the cable must be 7...12 mm or 0.28...0.47".*
- *Cable glands for cQPSus-approved devices must be supplied by the customer.*
- *A weather protection cover is available as an accessory with all devices.*

Metallic Horn antennas with threaded connections: Dimensions in mm

Horn antenna version	Dimensions [mm]				
	a	b	c	d	Øe
DN40/1½"	151	185	143 ①	328 ①	39
DN50/2"	151	185	157 ①	342 ①	43
DN65/2½"	151	185	232	417	65
DN80/3"	151	185	267 ①	452 ①	75
DN100/4"	151	185	335 ①	520 ①	95
DN150/6"	151	185	490 ①	675 ①	140
DN200/8"	151	185	662 ①	847 ①	190

Table 2-3: Metallic Horn antennas with threaded connections: Dimensions in mm

① This is the dimension without the antenna extension option. A maximum of 10 antenna extensions are available. Each antenna extension is 105 mm long.

Metallic Horn antennas with threaded connections: Dimensions in inches

Horn antenna version	Dimensions [inches]				
	a	b	c	d	Øe
DN40/1½"	5.94	11.14	5.63 ①	12.91 ①	1.54
DN50/2"	5.94	11.14	6.18 ①	13.46 ①	1.69
DN65/2½"	5.94	11.14	9.13	16.42	2.56
DN80/3"	5.94	11.14	10.51 ①	17.80 ①	2.95
DN100/4"	5.94	11.14	13.19 ①	20.47 ①	3.74
DN150/6"	5.94	11.14	19.29 ①	26.57 ①	5.51
DN200/8"	5.94	11.14	26.06 ①	33.35 ①	7.48

Table 2-4: Metallic Horn antennas with threaded connections: Dimensions in inches

① This is the dimension without the antenna extension option. A maximum of 10 antenna extensions are available. Each antenna extension is 4.1" long.

Metallic Horn antenna versions with standard flange connections

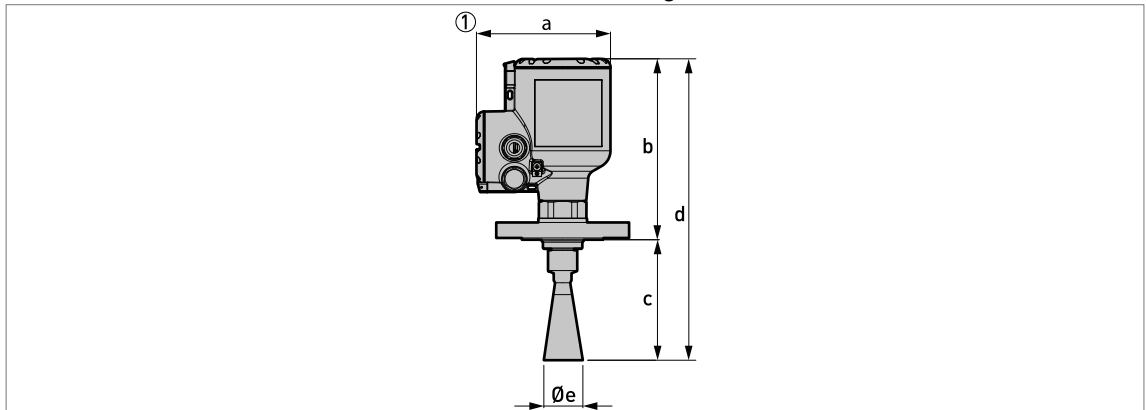

Figure 2-10: Metallic Horn antennas with standard flange connections

① Metallic Horn antenna with a flange connection

- *The diameter of the outer sheath of the cable must be 7...12 mm or 0.28...0.47".*
- *Cable glands for cQPSus-approved devices must be supplied by the customer.*
- *A weather protection cover is available as an accessory with all devices.*

Metallic Horn antennas with standard flange connections: Dimensions in mm

Horn antenna version	Dimensions [mm]				
	a	b	c	d	Øe
DN40/1½"	151	203...215.6	130...143 ①	333...358 ①	39
DN50/2"	151	203...215.6	144...157 ①	347...372 ①	43
DN65/2½"	151	203...215.6	219...230	422...447	65
DN80/3"	151	203...215.6	254...267 ①	457...482 ①	75
DN100/4"	151	203...215.6	322...335 ①	525...550 ①	95
DN150/6"	151	203...215.6	477...490 ①	680...705 ①	140
DN200/8"	151	203...215.6	649...662 ①	852...877 ①	190

Table 2-5: Metallic Horn antennas with standard flange connections: Dimensions in mm

① These are the minimum and maximum values without the antenna extension option. A maximum of 10 antenna extensions are available. Each antenna extension is 105 mm long.

Metallic Horn antennas with standard flange connections: Dimensions in inches

Horn antenna version	Dimensions [inches]				
	a	b	c	d	Øe
DN40/1½"	5.94	7.99...8.49	5.12...5.63 ①	13.11...14.09 ①	1.54
DN50/2"	5.94	7.99...8.49	5.67...6.18 ①	13.66...14.64 ①	1.69
DN65/2½"	5.94	7.99...8.49	8.62...9.05	16.61...17.60	2.56
DN80/3"	5.94	7.99...8.49	10.00...10.51 ①	17.99...18.98 ①	2.95
DN100/4"	5.94	7.99...8.49	12.68...13.19 ①	20.67...21.65 ①	3.74
DN150/6"	5.94	7.99...8.49	18.78...19.29 ①	26.77...27.76 ①	5.51
DN200/8"	5.94	7.99...8.49	25.55...26.06 ①	33.54...34.53 ①	7.48

Table 2-6: Metallic Horn antennas with standard flange connections: Dimensions in inches

① These are the minimum and maximum values without the antenna extension option. A maximum of 10 antenna extensions are available. Each antenna extension is 4.1" long.

Metallic Horn antenna versions with low-pressure flange connections

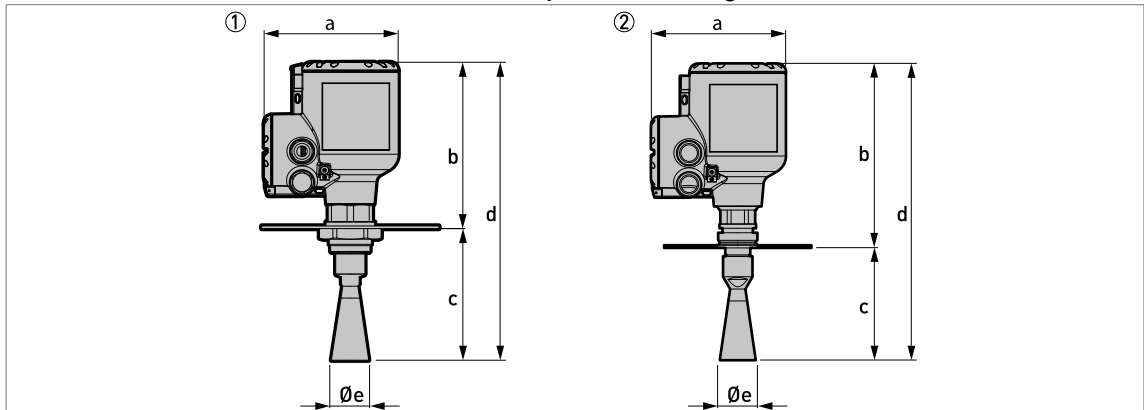

Figure 2-11: Metallic Horn antennas with low-pressure flange connections

- ① Metallic Horn antenna with a low-pressure flange attached to a G threaded connection (ISO 228-1)
- ② Metallic Horn antenna with a low-pressure flange attached to an NPT threaded connection (ASME B1.20.1)

- *The diameter of the outer sheath of the cable must be 7...12 mm or 0.28...0.47".*
- *Cable glands for cQPSus-approved devices must be supplied by the customer.*
- *A weather protection cover is available as an accessory with all devices.*

Metallic Horn antennas with low-pressure flange connections: Dimensions in mm

Horn antenna version	Dimensions [mm]						
	a	b		c	d		Øe
		G	NPT		G	NPT	
DN40/1½"	151	215	247	138 ①	328 ①	385 ①	39
DN50/2"	151	215	247	152 ①	342 ①	399 ①	43
DN65/2½"	151	215	247	227	417	474	65
DN80/3"	151	215	247	262 ①	452 ①	507 ①	75
DN100/4"	151	215	247	331 ①	521 ①	578 ①	95
DN150/6"	151	215	247	486 ①	675 ①	733 ①	140
DN200/8"	151	215	247	657 ①	847 ①	904 ①	190

Table 2-7: Metallic Horn antennas with low-pressure flange connections: Dimensions in mm

① This is the dimension without the antenna extension option. A maximum of 10 antenna extensions are available. Each antenna extension is 105 mm long.

Metallic Horn antennas with low-pressure flange connections: Dimensions in inches

Horn antenna version	Dimensions [inches]						
	a	b		c	d		Øe
		G	NPT		G	NPT	
DN40/1½"	5.94	8.46	9.72	5.43 ①	12.91 ①	15.16 ①	1.54
DN50/2"	5.94	8.46	9.72	5.98 ①	13.46 ①	15.71 ①	1.69
DN65/2½"	5.94	8.46	9.72	8.94	16.42	18.66	2.56
DN80/3"	5.94	8.46	9.72	10.31 ①	17.80 ①	19.96 ①	2.95
DN100/4"	5.94	8.46	9.72	13.03 ①	20.51 ①	22.76 ①	3.74
DN150/6"	5.94	8.46	9.72	19.13 ①	26.57 ①	28.86 ①	5.51
DN200/8"	5.94	8.46	9.72	25.87 ①	33.35 ①	35.59 ①	7.48

Table 2-8: Metallic Horn antennas with low-pressure flange connections: Dimensions in inches

① This is the dimension without the antenna extension option. A maximum of 10 antenna extensions are available. Each antenna extension is 4.1" long.

Drop antennas with threaded connections

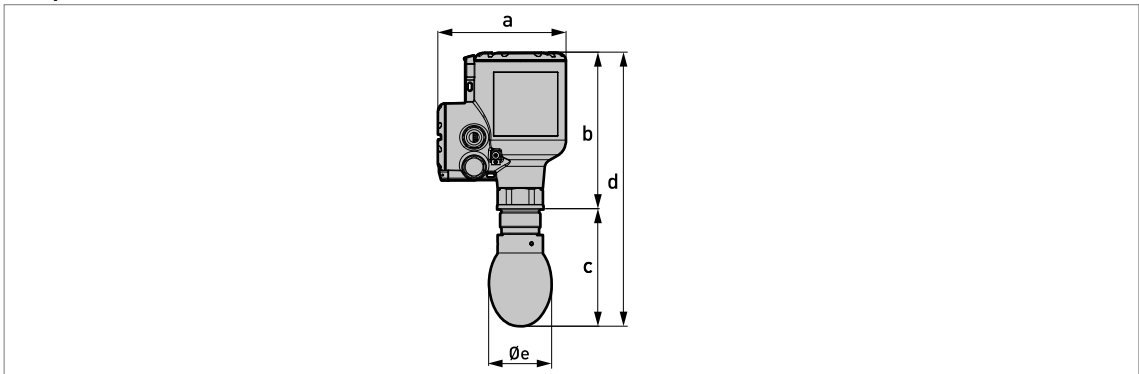

Figure 2-12: Drop antennas with threaded connections

- The diameter of the outer sheath of the cable must be 7...12 mm or 0.28...0.47".
- Cable glands for cQPSus-approved devices must be supplied by the customer.
- A weather protection cover is available as an accessory with all devices.

Drop antennas with threaded connections: Dimensions in mm

Drop antenna version	Dimensions [mm]				
	a	b	c	d	Øe
DN80/3"	151	185	137 ①	322 ①	74
DN100/4"	151	185	160 ①	345 ①	94
DN150/6"	151	185	216 ①	401 ①	144

Table 2-9: Drop antennas with threaded connections: Dimensions in mm

① This is the dimension without the antenna extension option. A maximum of 5 antenna extensions are available. Each antenna extension is 105 mm long.

Drop antennas with threaded connections: Dimensions in inches

Drop antenna version	Dimensions [inches]				
	a	b	c	d	Øe
DN80/3"	5.94	7.28	5.39 ①	12.68 ①	2.91
DN100/4"	5.94	7.28	6.30 ①	13.58 ①	3.70
DN150/6"	5.94	7.28	8.50 ①	15.78 ①	5.67

Table 2-10: Drop antennas with threaded connections: Dimensions in inches

① This is the dimension without the antenna extension option. A maximum of 5 antenna extensions are available. Each antenna extension is 4.1" long.

Drop antennas with standard flange connections

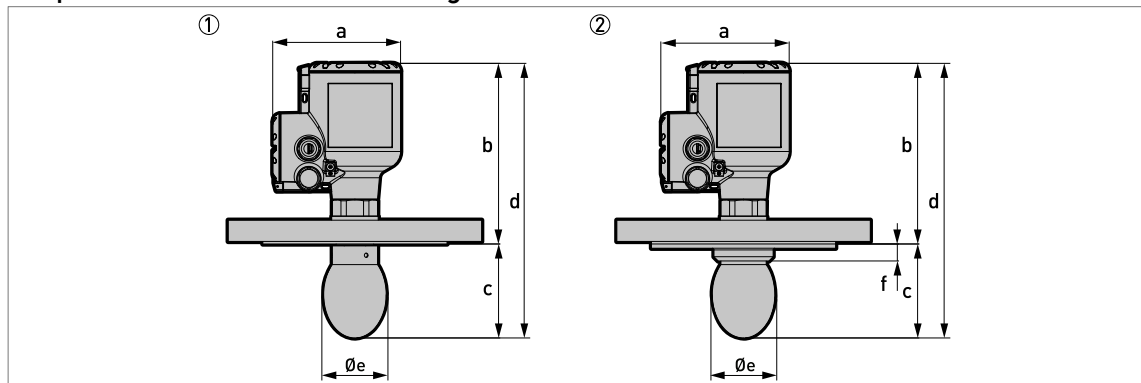

Figure 2-13: Drop antennas with standard flange connections

- ① Drop antenna with a flange connection
 ② Drop antenna with a flange connection and a flange plate protection option

- The diameter of the outer sheath of the cable must be 7...12 mm or 0.28...0.47".
- Cable glands for cQPSus-approved devices must be supplied by the customer.
- A weather protection cover is available as an accessory with all devices.

Drop antennas with standard flange connections: Dimensions in mm

Drop antenna version	Dimensions [mm]					
	a	b	c	d	Øe	f
DN80/3"	151	203...215.6	124...136 ①	327...352 ①	74	20 ②
DN100/4"	151	203...215.6	147...159 ①	350...375 ①	94	20 ②
DN150/6"	151	203...215.6	203...216 ①	411...436 ①	144	20 ②

Table 2-11: Drop antennas with standard flange connections: Dimensions in mm

- ① These are the minimum and maximum values without the antenna extension option. A maximum of 5 antenna extensions are available. Each antenna extension is 105 mm long.
 ② If the device has the PP flange protection option

Drop antennas with standard flange connections: Dimensions in inches

Drop antenna version	Dimensions [inches]					
	a	b	c	d	Øe	f
DN80/3"	5.94	7.99...8.49	4.88...5.35 ①	12.87...13.86 ①	2.91	0.79 ②
DN100/4"	5.94	7.99...8.49	5.79...6.26 ①	13.78...14.76 ①	3.70	0.79 ②
DN150/6"	5.94	7.99...8.49	7.99...8.46 ①	15.98...16.97 ①	5.67	0.79 ②

Table 2-12: Drop antennas with standard flange connections: Dimensions in inches

- ① These are the minimum and maximum values without the antenna extension option. A maximum of 5 antenna extensions are available. Each antenna extension is 4.1" long.
 ② If the device has the PP flange protection option

Drop antennas with low-pressure flange connections

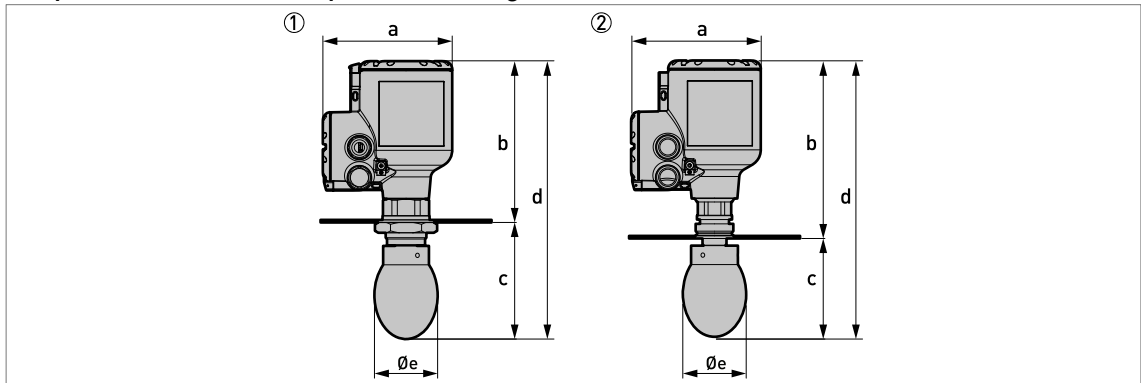

Figure 2-14: Drop antennas with low-pressure flange connections

- ① Drop antenna with a low-pressure flange attached to a G threaded connection (ISO 228-1)
- ② Drop antenna with a low-pressure flange attached to an NPT threaded connection (ASME B1.20.1)

- The diameter of the outer sheath of the cable must be 7...12 mm or 0.28...0.47".
- Cable glands for cQPSus-approved devices must be supplied by the customer.
- A weather protection cover is available as an accessory with all devices.

Drop antennas with low-pressure flange connections: Dimensions in mm

Drop antenna version	Dimensions [mm]						
	a	b		c	d		Øe
		G	NPT		G	NPT	
DN80/3"	151	188	220	136 ①	324 ①	356 ①	74
DN100/4"	151	188	220	159 ①	347 ①	379 ①	94
DN150/6"	151	188	220	217 ①	405 ①	437 ①	144

Table 2-13: Drop antennas with low-pressure flange connections: Dimensions in mm

① This is the dimension without the antenna extension option. A maximum of 5 antenna extensions are available. Each antenna extension is 105 mm long.

Drop antennas with low-pressure flange connections: Dimensions in inches

Drop antenna version	Dimensions [mm]						
	a	b		c	d		Øe
		G	NPT		G	NPT	
DN80/3"	5.94	7.40	8.66	5.35 ①	12.76 ①	14.01 ①	2.91
DN100/4"	5.94	7.40	8.66	6.26 ①	13.66 ①	14.92 ①	3.70
DN150/6"	5.94	7.40	8.66	8.54 ①	15.94 ①	17.20 ①	5.67

Table 2-14: Drop antennas with low-pressure flange connections: Dimensions in inches

① This is the dimension without the antenna extension option. A maximum of 5 antenna extensions are available. Each antenna extension is 4.1" long.

Purging option

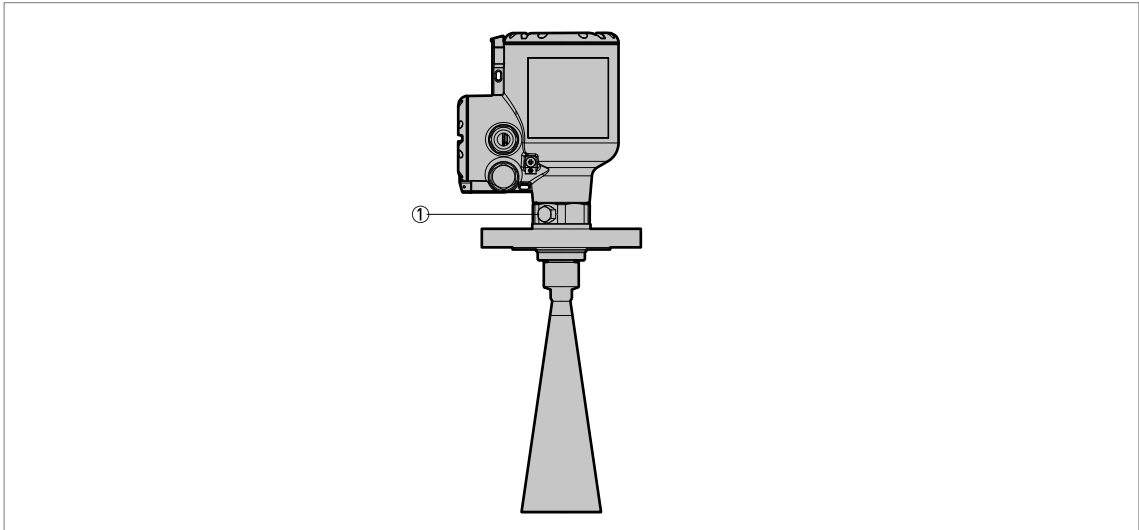

Figure 2-15: Purging options

- ① 1/8 - 27 NPTF threaded connection for purging system (the plug is supplied by the manufacturer)

Purging system

This option is available for all Metallic Horn antennas. Flange connections must have a pressure rating of PN16 (EN 1092-1), PN40 (EN 1092-1), Class 150 (ASME B16.5), Class 300 (ASME B16.5), or must be a low-pressure flange (PN01 / 15 psig).

Stainless-steel cover options

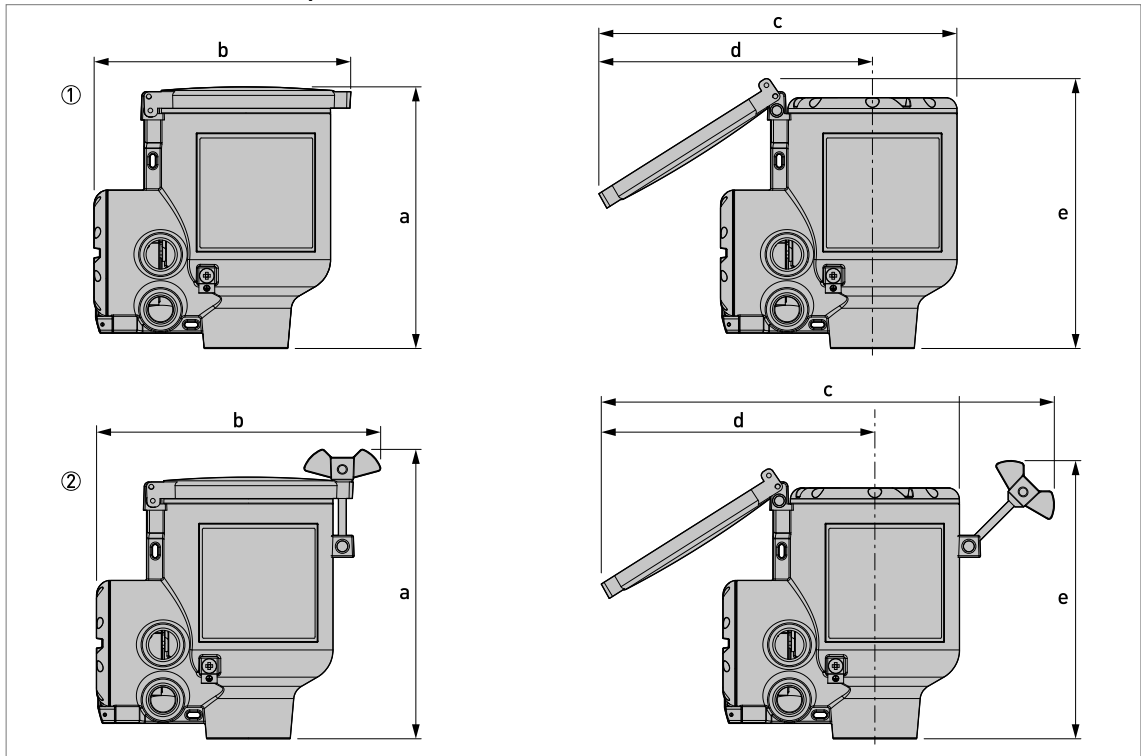

Figure 2-16: Stainless-steel cover options

- ① Signal converter housing with stainless-steel cover - without locking system
- ② Signal converter housing with stainless-steel cover - with locking system

	Dimensions									
	a		b		c		d		e	
	[mm]	[inch]	[mm]	[inch]	[mm]	[inch]	[mm]	[inch]	[mm]	[inch]
Without locking system	167	6.57	164	6.46	229	9.02	175	6.89	172	6.77
With locking system	184	7.24	181	7.13	289	11.38	175	6.89	177	6.97

Table 2-15: Stainless-steel cover options

Weather protection option

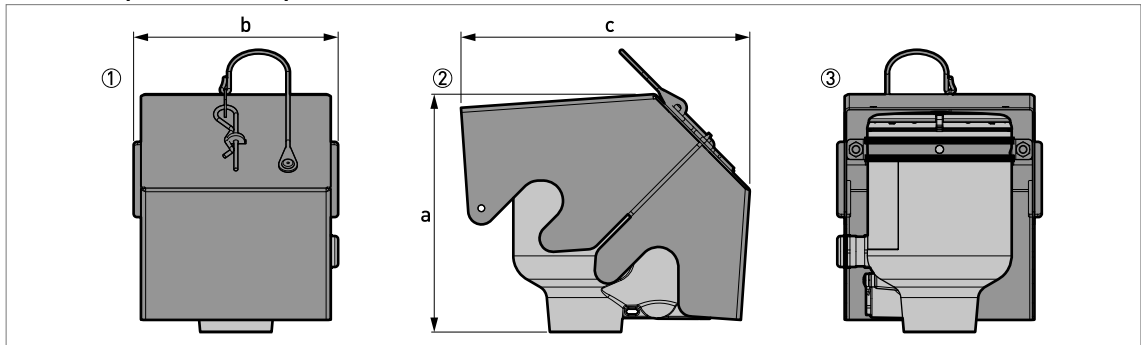

Figure 2-17: Weather protection option

- ① Front view (with weather protection closed)
- ② Left side (with weather protection closed)
- ③ Rear view (with weather protection closed)

	Dimensions						Weights	
	a		b		c			
	[mm]	[inch]	[mm]	[inch]	[mm]	[inch]	[kg]	[lb]
Weather protection	177	6.97	153	6.02	216	8.50	1.3	2.9

Table 2-16: Weather protection option

Converter weight

Type of housing	Weights	
	[kg]	[lb]
Compact aluminium housing	2.1	4.6
Compact stainless-steel housing	4.5	9.9

Table 2-17: Converter weight

Antenna option weights

Antenna options	Min./Max. weights	
	[kg]	[lb]

Standard options, without converter

DN40 / 1.5" Metallic Horn antenna with process connection, standard length ①	2.3...58.7	5...129.1
DN50 / 2" Metallic Horn antenna with process connection, standard length ①	2.3...58.7	5...129.1
DN65 / 2.5" Metallic Horn antenna with process connection, standard length ①	2.5...58.9	5.5...129.6
DN80 / 3" Metallic Horn antenna with process connection, standard length ①	2.5...58.9	5.5...129.6
DN100 / 4" Metallic Horn antenna with process connection, standard length ①	2.6...59	5.7...129.8
DN150 / 6" Metallic Horn antenna with process connection, standard length ①	3...59.4	6.6...130.7
DN200 / 8" Metallic Horn antenna with process connection, standard length ①	3.7...60	8.1...132
DN80 / 3" PP Drop antenna with process connection, standard length ①	2.7...59.1	5.9...130
DN100 / 4" PP Drop antenna with process connection, standard length ①	3.1...59.5	6.8...131.2
DN150 / 6" PP Drop antenna with process connection, standard length ①	4.5...60.9	9.9...134

Antenna extension options

Straight extension, length 105 mm / 4.13" ②	+0.92	+2.03
Straight extension, length 210 mm / 8.27" ②	+1.84	+4.06
Straight extension, length 315 mm / 12.40" ②	+2.76	+6.08
Straight extension, length 420 mm / 16.54" ②	+3.68	+8.11
Straight extension, length 525 mm / 20.67" ②	+4.60	+10.14
Straight extension, length 630 mm / 24.80" ③	+5.52	+12.17
Straight extension, length 735 mm / 28.94" ③	+6.44	+14.20
Straight extension, length 840 mm / 33.07" ③	+7.36	+16.23
Straight extension, length 945 mm / 37.20" ③	+8.28	+18.25
Straight extension, length 1050 mm / 41.34" ③	+9.20	+20.28

Other options

Flange plate option, DN80 / 3" PP Drop antenna	+0.1	+0.22
Flange plate option, DN100 / 4" PP Drop antenna	+0.2	+0.44
Flange plate option, DN150 / 6" PP Drop antenna	+0.3	+0.66

Table 2-18: Antenna option weights

- ① Standard length = without antenna extensions
- ② This option is for Metallic Horn and Drop antennas
- ③ This option is for Metallic Horn antennas

3.1 Intended use

Responsibility for the use of the measuring devices with regard to suitability, intended use and corrosion resistance of the used materials against the measured fluid lies solely with the operator.

The manufacturer is not liable for any damage resulting from improper use or use for other than the intended purpose.

This radar level transmitter measures distance, level, mass, volume and reflectivity of liquids, pastes and slurries.

It can be installed on tanks, reactors, open channels and open water.

3.2 Pre-installation requirements

Obey the precautions that follow to make sure that the device is correctly installed.

- Make sure that there is sufficient space on all sides.
- Protect the signal converter from direct sunlight. If necessary, install the weather protection accessory.
- Do not subject the signal converter to heavy vibrations. The devices are tested for vibration and agree with IEC 60068-2-6.

3.3 Installation

3.3.1 Pressure and temperature ranges

The process connection temperature range must agree with the temperature limits of the gasket material. The operating pressure range is subject to the process connection used and the flange temperature.

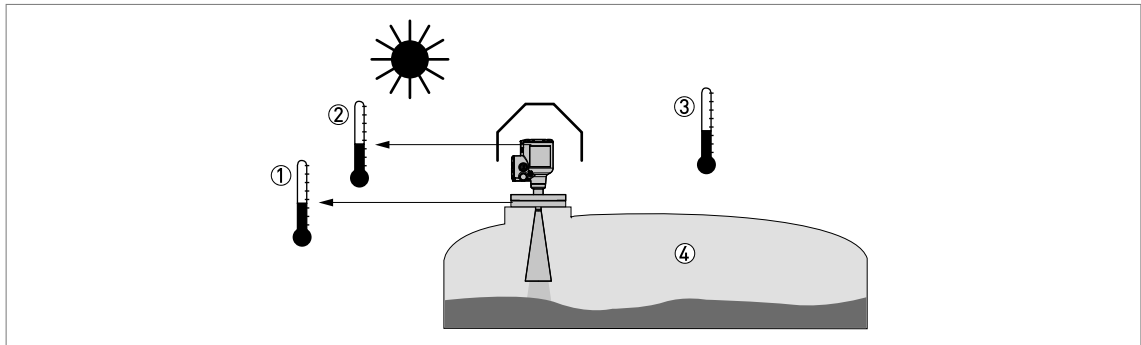

Figure 3-1: Pressure and temperature ranges

- ① Temperature at the process connection
Non-Ex devices: The temperature range depends on the type of antenna, process connection and the seal material. Refer to the table that follows.
Devices with Hazardous Location approvals: see supplementary instructions
- ② Ambient temperature for operation of the display
-20...+70°C / -4...+158°F
If the ambient temperature is not between these limits, then it is possible that the display screen will not operate temporarily. The device continues to measure level and send an output signal.
- ③ Ambient temperature
Non-Ex devices: -40...+80°C / -40...+176°F
Devices with Hazardous Location approvals: see supplementary instructions
- ④ Process pressure
Depends on the type of antenna and process connection. Refer to the table that follows.

Maximum process connection temperature and operating pressure

Antenna type	Maximum process connection temperature		Maximum operating pressure	
	[°C]	[°F]	[barg]	[psig]
PP Drop	+100	+212	16	232
Metallic Horn	+130 ①	+266 ①	16	232

Table 3-1: Maximum process connection temperature and operating pressure

- ① The maximum process connection temperature must agree with the temperature limits of the gasket material

For more data on pressure ratings, refer to *Guidelines for maximum operating pressure* on page 20.

3.3.2 Recommended mounting position

Follow these recommendations to make sure that the device measures correctly. They have an effect on the performance of the device.

We recommend that you prepare the installation when the tank is empty.

Recommended nozzle position for liquids, pastes and slurries

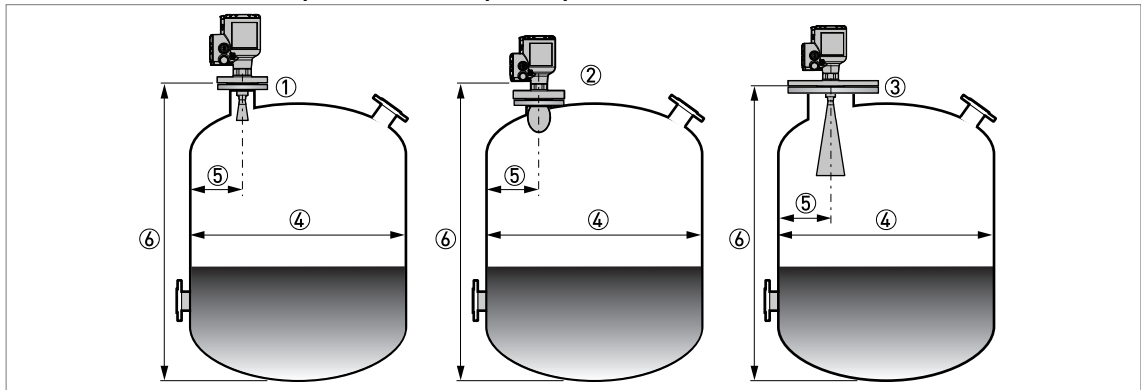

Figure 3-2: Recommended nozzle position for liquids, pastes and slurries

- ① Nozzle or socket for the DN40 (1½") or DN50 (2") Metallic Horn antennas
- ② Nozzle or socket for the DN80 (3") or DN100 (4") Metallic Horn antenna, and the DN80 (3") Drop antenna
- ③ Nozzle or socket for the DN150 (6") or DN200 (8") Metallic Horn antenna, and the DN100 (4") or DN150 (6") Drop antenna
- ④ Tank diameter
- ⑤ Minimum distance of the nozzle or socket from the tank wall (depends on the antenna type and size – refer to items ①, ② and ③ in this list):
 - DN40 (1½") or DN50 (2") Metallic Horn: $1/5 \times$ tank height
 - DN80 (3") or DN100 (4") Metallic Horn: $1/10 \times$ tank height
 - DN80 (3") Drop: $1/10 \times$ tank height
 - DN150 (6") or DN200 (8") Metallic Horn: $1/20 \times$ tank height
 - DN100 (4") or DN150 (6") Drop: $1/20 \times$ tank height
- Maximum distance of the nozzle or socket from the tank wall (depends on the antenna type and size – refer to items ①, ② and ③ in this list):
 - Metallic Horn or Drop: $1/3 \times$ tank diameter
- ⑥ Tank height

If there is a nozzle on the tank before installation, the nozzle must be a minimum of 200 mm / 7.9" from the tank wall. The tank wall must be flat and there must not be obstacles adjacent to the nozzle or on the tank wall.

Number of devices that can be operated in a tank

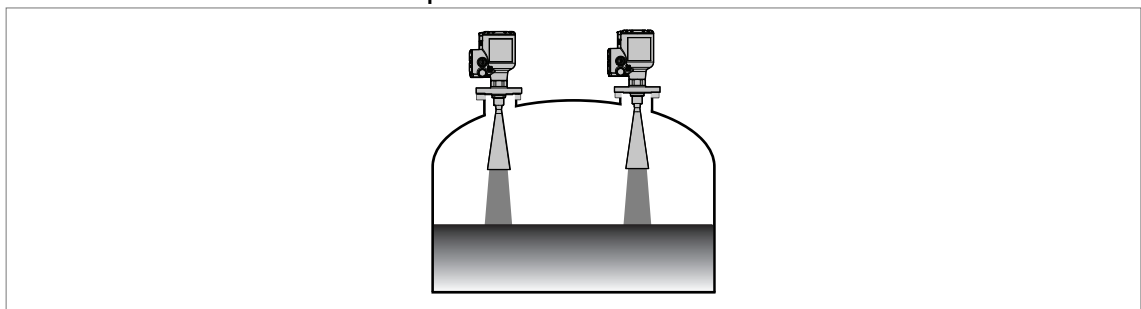

Figure 3-3: There is no maximum limit to the number of devices that can be operated in the same tank

There is no maximum limit to the number of devices that can be operated in the same tank. They can be installed adjacent to other radar level transmitters.

3.3.3 Mounting restrictions

LPR and TLPR devices

LPR (Level Probing Radar) devices measure level in the open air or in a closed space (a metallic tank etc.). TLPR (Tank Level Probing Radar) devices measure level in a closed space only. You can use LPR devices for TLPR applications. .

Causes of interference signals

- Objects in the tank or pit.
- Sharp corners that are perpendicular to the path of the radar beam.
- Sudden changes in tank diameter in the path of the radar beam.

Do not install the device above objects in the tank (ladder, supports etc.) or pit. Objects in the tank or pit can cause interference signals. If there are interference signals, the device will not measure correctly.

If it is not possible to install the device on another part of the tank or pit, do an empty spectrum scan. For more data, refer to the handbook.

Equipment and obstacles: how to prevent measurement of interference signals

Do not put the device immediately above equipment and obstacles in a tank or pit. This can have an effect on the performance of the device.

If possible, do not install a nozzle on the tank centerline.

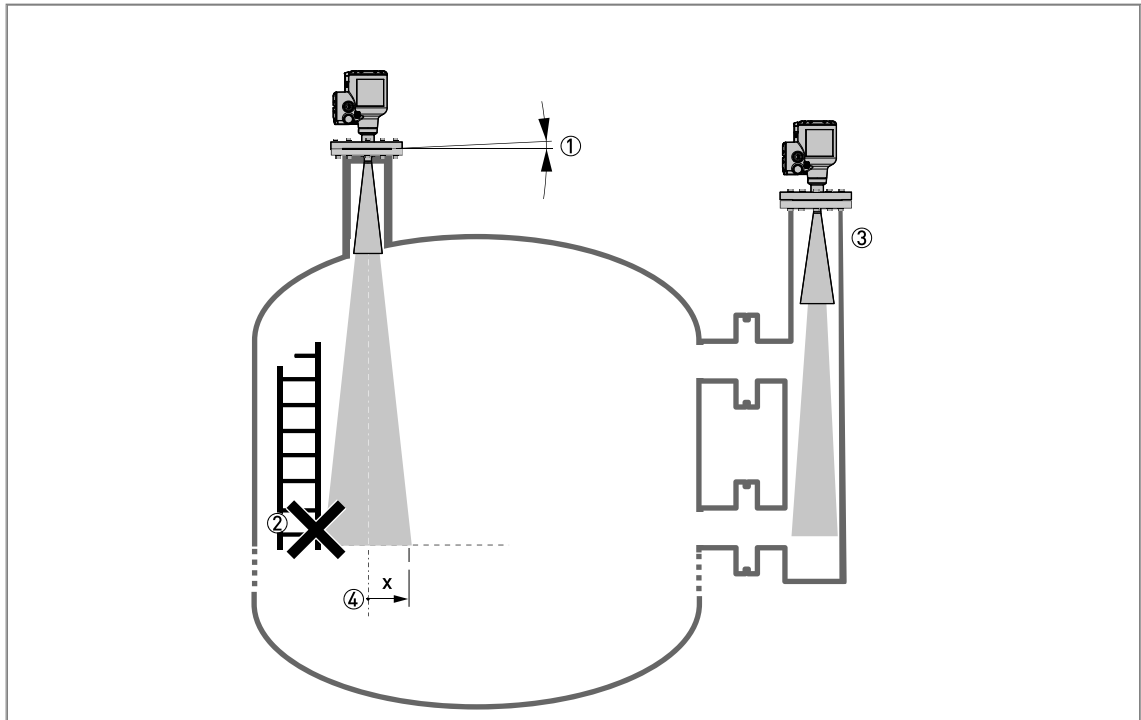

Figure 3-4: Equipment and obstacles: how to prevent measurement of interference signals

- ① Do not tilt the device more than 2°
- ② We recommend that you do an empty spectrum recording if there are too many obstacles in the radar beam (refer to the handbook).
- ③ If there are too many obstacles in the tank, you can install the device on a standpipe. For more data about how to install the device on standpipes, refer to *Standpipes (stilling wells and bypass chambers)* on page 43.
- ④ Beam radius of the antenna: refer to the table below. The beam radius increases by increments of "x" mm for each metre of distance from the antenna.

Beam radius of the antenna

Antenna type	Beam angle	Beam radius, x	
		[mm/m]	[in/ft]
Metallic Horn, DN40 [1½"]	17°	150	1.8
Metallic Horn, DN50 [2"]	16°	141	1.7
Metallic Horn, DN65 [2½"]	10° ①	①	①
Metallic Horn, DN80 [3"]	9°	79	0.9
Metallic Horn, DN100 [4"]	8°	70	0.8
Metallic Horn, DN150 [6"]	6°	53	0.6
Metallic Horn, DN200 [8"]	5°	44	0.5
PP Drop DN80 [3"]	9°	79	0.9
PP Drop, DN100 [4"]	7°	61	0.7
PP Drop, DN150 [6"]	5°	44	0.5

Table 3-2: Beam radius of the antenna

- ① This antenna option is specially made for the BM 26 A

Product inlets

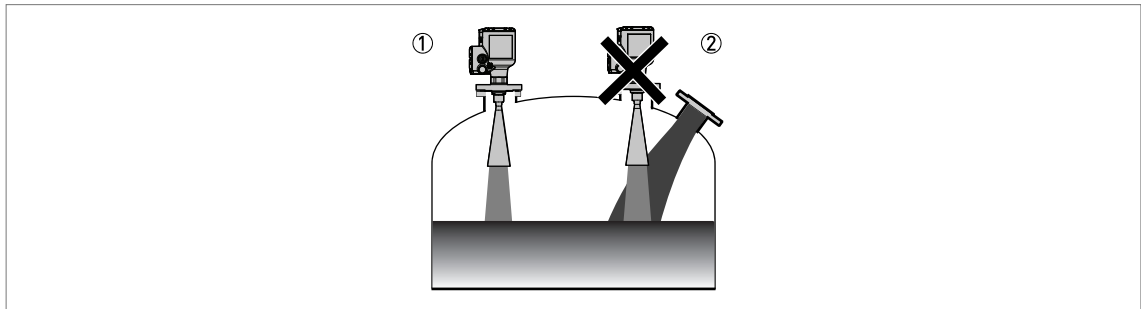

Figure 3-5: Product inlets

- ① The device is in the correct position.
- ② The device is too near to the product inlet.

Do not put the device near to the product inlet. If the product that enters the tank touches the antenna, the device will measure incorrectly. If the product fills the tank directly below the antenna, the device will also measure incorrectly.

For more data about the measuring range of each type of antenna, refer to Measuring accuracy on page 18.

Installation height above mean sea level

Attach the weather protection accessory to the device if you install it more than 2000 m / 6560 ft above mean sea level.

3.3.4 Process connections

All the procedures that follow are applicable to Metallic Horn and Drop antennas.

Flange connections

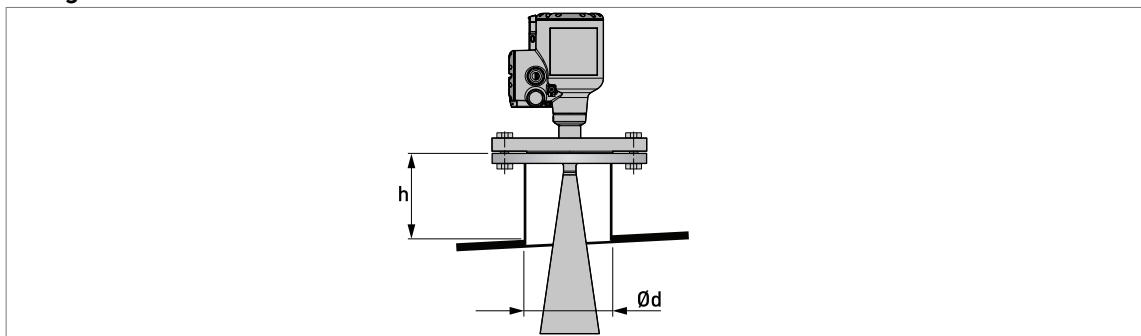

Figure 3-6: Flange connections

$\varnothing d$ = nozzle diameter
 h = nozzle height

Recommended nozzle size for flange connections

The nozzle must be as short as possible. Refer to the table below for the maximum height of the nozzle:

Nozzle and antenna diameter, Ød		Maximum nozzle height, h			
		Metallic Horn antenna		Drop antenna	
[mm]	[inch]	[mm]	[inch]	[mm]	[inch]
40	1½	140 ①	5.51 ①	—	—
50	2	150 ①	5.91 ①	—	—
80	3	260 ①	10.24 ①	60 ①	2.36 ①
100	4	330 ①	12.99 ①	70 ①	2.76 ①
150	6	490 ①	19.29 ①	100 ①	3.94 ①
200	8	660 ①	25.98 ①	—	—

Table 3-3: Recommended nozzle size for flange connections

① If the device has antenna extensions, this option extends the maximum nozzle height. Add the length of the antenna extensions attached to the device to this value.

Threaded connections

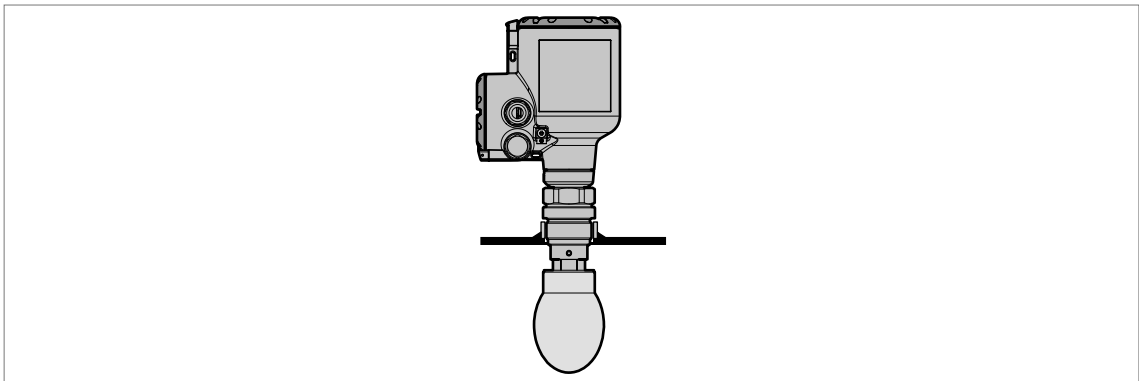

Figure 3-7: Threaded connections

Recommended socket size for threaded connections

The socket must be as short as possible. If the socket is in a recess, then use the maximum limits for nozzle dimensions (flange connections) in this section.

If the device has antenna extensions, this option extends the maximum socket height. Add the length of the antenna extensions attached to the device to this value.

3.3.5 LPR devices: recommendations for pits and tanks made of non-conductive materials

These instructions are for LPR equipment only. .

Device installation on tanks made of a non-conductive material

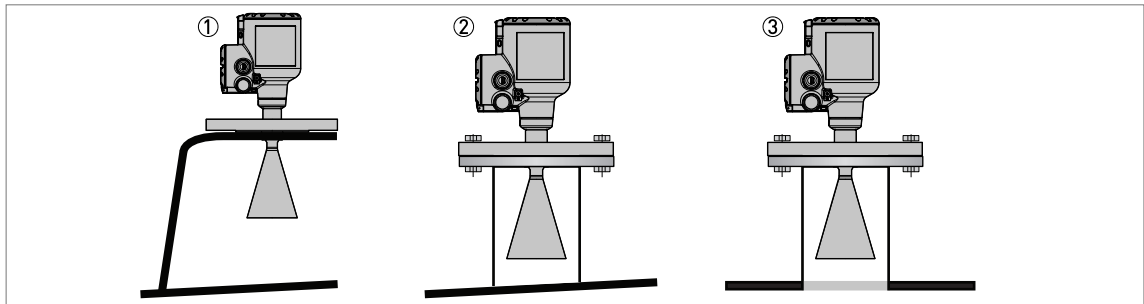

Figure 3-8: Device installation on tanks made of a non-conductive material

- ① LPR equipment on a basic support (for indoor installations)
- ② LPR equipment on a sealed support
- ③ LPR equipment on a tank made of conductive material, but with a non-conductive, sealed "window"

If the device cannot go in the tank and the tank is made of a non-conductive material (plastic etc.), you can attach a support to the top of the tank without a hole in the tank roof. We recommend that you put the antenna as near as possible to the top of the tank.

If the tank is outdoors, we recommend that you seal the support. If rain is on the top of the tank and directly below the device, this can have an effect on the device performance.

If device is used in dusty conditions, we recommend that you seal the support. If dust is on the top of the tank and directly below the device, this can have an effect on the device performance.

Open pits

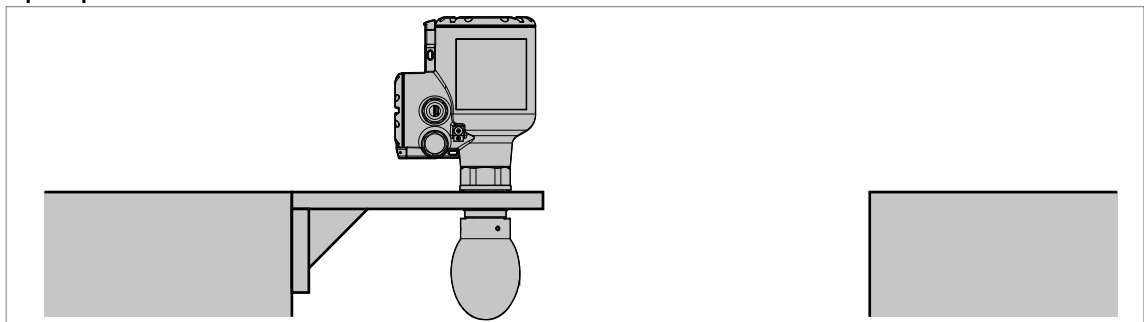

Figure 3-9: Open pits

If the device must measure the level of product in a pit, you can attach a support to the side of the pit or above the pit.

3.3.6 Standpipes (stilling wells and bypass chambers)

These instructions are applicable for devices with Metallic Horn antenna options only. Use a standpipe if:

- There is highly conductive foam in the tank.
- The liquid is very turbulent or agitated.
- There are too many other objects in the tank.
- The device is measuring a liquid (petrochemicals) in a tank with a floating roof.
- The device is installed in a horizontal cylindrical tank.

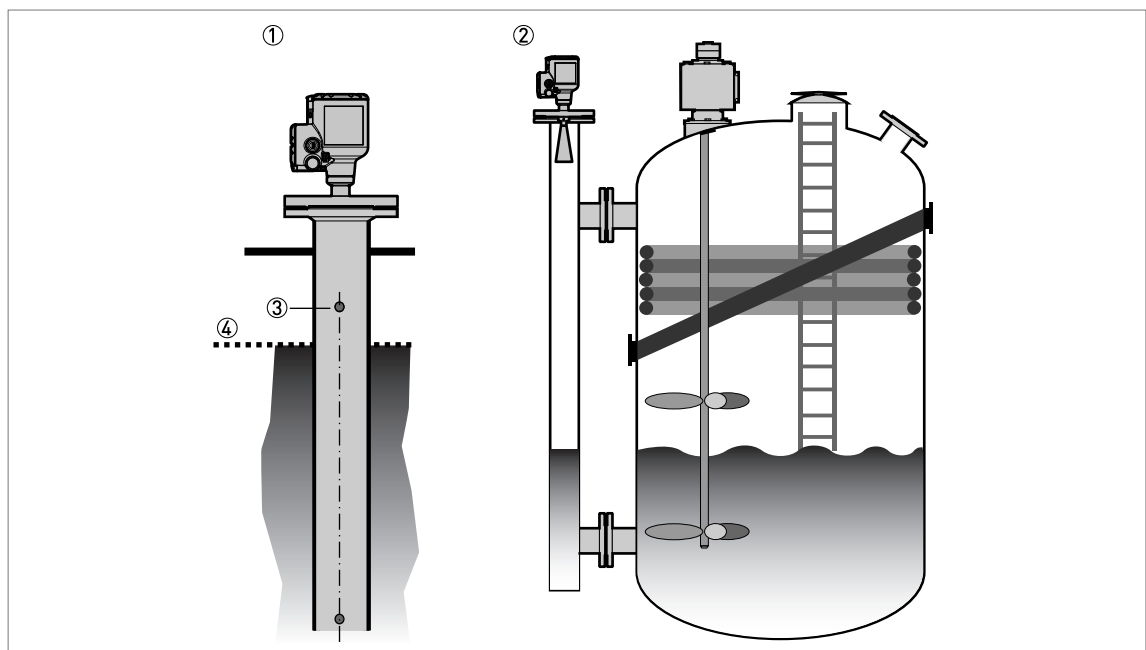

Figure 3-10: Installation recommendations for standpipes (stilling wells and bypass chambers)

- ① A stilling well solution
- ② A bypass chamber solution
- ③ Air circulation hole
- ④ Level of the liquid

- *The standpipe must be electrically conductive.*
- *The inside diameter of the standpipe must not be more than 5 mm / 0.2" over the diameter of the antenna (for a high-dielectric constant liquid).*
- *The standpipe must be straight. There must be no sudden changes in internal diameter greater than 1 mm / 0.04".*
- *The standpipe must be vertical.*
- *Recommended surface roughness: $\leq \pm 0.1$ mm / 0.004".*
- *Make sure that there are no deposits at the bottom of the standpipe.*
- *Make sure that there is liquid in the standpipe.*

You must drill an air circulation hole.

Installation in tanks containing one liquid and foam

- Drill an air circulation hole (max. $\varnothing 10$ mm / 0.4") in the stilling well above the maximum level.
- Remove the burr from the hole.

Installation in tanks containing one liquid or more without foam

- Drill an air circulation hole (max. $\varnothing 10$ mm / 0.4") in the stilling well above the maximum level.
- Drill 1 or more liquid circulation holes in the stilling well (if there is more than 1 liquid in the tank).
- ➡ These holes help the liquid to move freely between the stilling well and the tank.
- Remove the burr from the hole.

Stilling wells: floating roofs

If the device must be installed on a tank with a floating roof, install it in a stilling well made of metal.

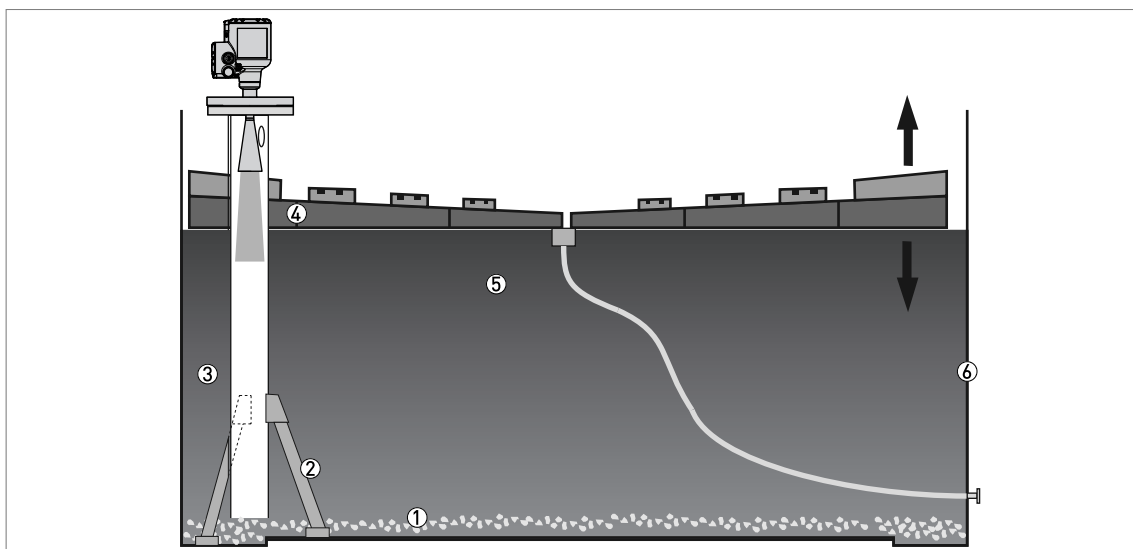

Figure 3-11: Floating roofs

- ① Sediment
- ② Support fixtures
- ③ Stilling well
- ④ Floating roof
- ⑤ Product
- ⑥ Tank

Stilling wells: horizontal cylindrical tanks

We recommend that you install the device in a stilling well if the device:

- is for a horizontal cylindrical tank,
- is in a metallic tank,
- measures a product with a high dielectric constant and
- is on the centerline of the tank.

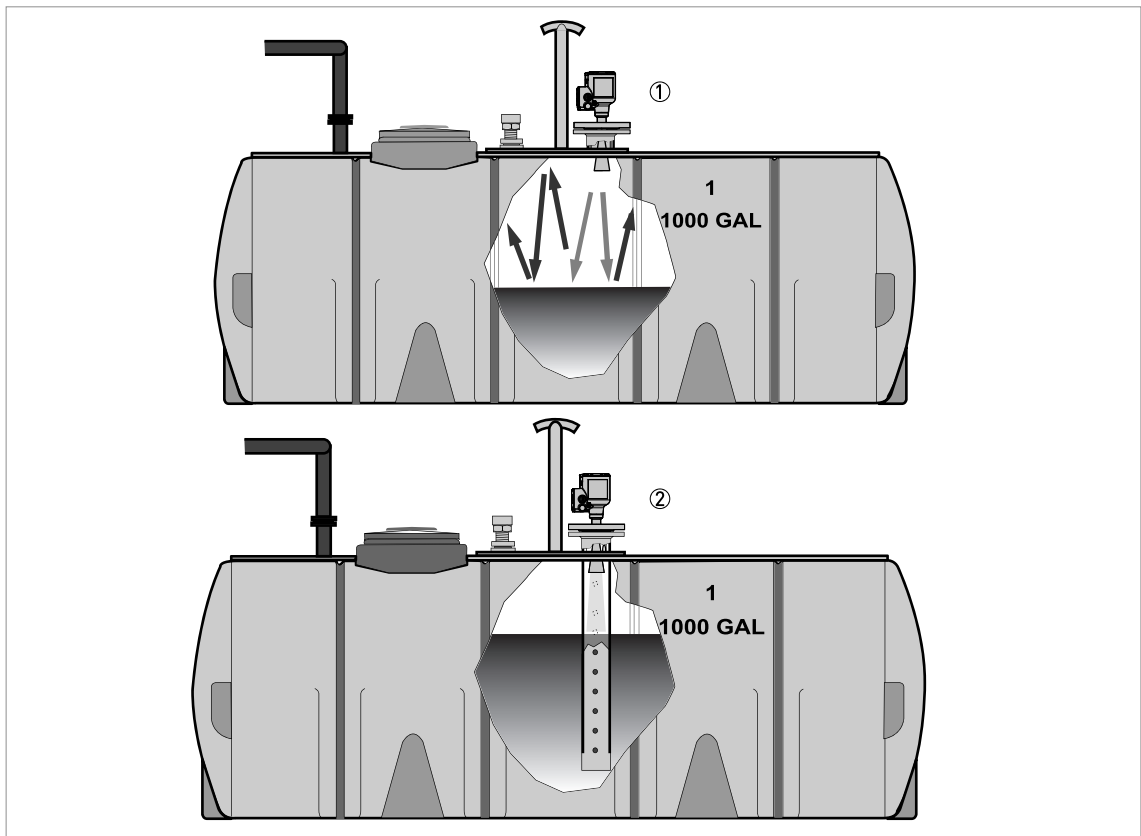

Figure 3-12: Horizontal cylindrical tanks

- ① The device is installed without a stilling well. There are multiple reflections. Refer to the CAUTION! that follows.
- ② The device is installed in a stilling well and measures correctly.

If the device is installed in horizontal cylindrical tank that contains a high dielectric constant liquid without a stilling well, do not put it on the tank centerline. This will cause multiple reflections and the device will not measure accurately. Use the device software to keep the effects of multiple reflections to a minimum. For more data, refer to "Function description" in the handbook.

Bypass chambers

Installation next to tanks containing one liquid and foam

- The top process connection of the bypass chamber must be above the maximum level of liquid.
- The bottom process connection of the bypass chamber must be below the lowest measured level of liquid.

Installation next to tanks containing more than one liquid

- The top process connection of the bypass chamber must be above the maximum level of liquid.
- The bottom process connection of the bypass chamber must be below the lowest measured level of liquid.
- Additional process connections are necessary for the liquids to circulate freely along the length of the bypass chamber.

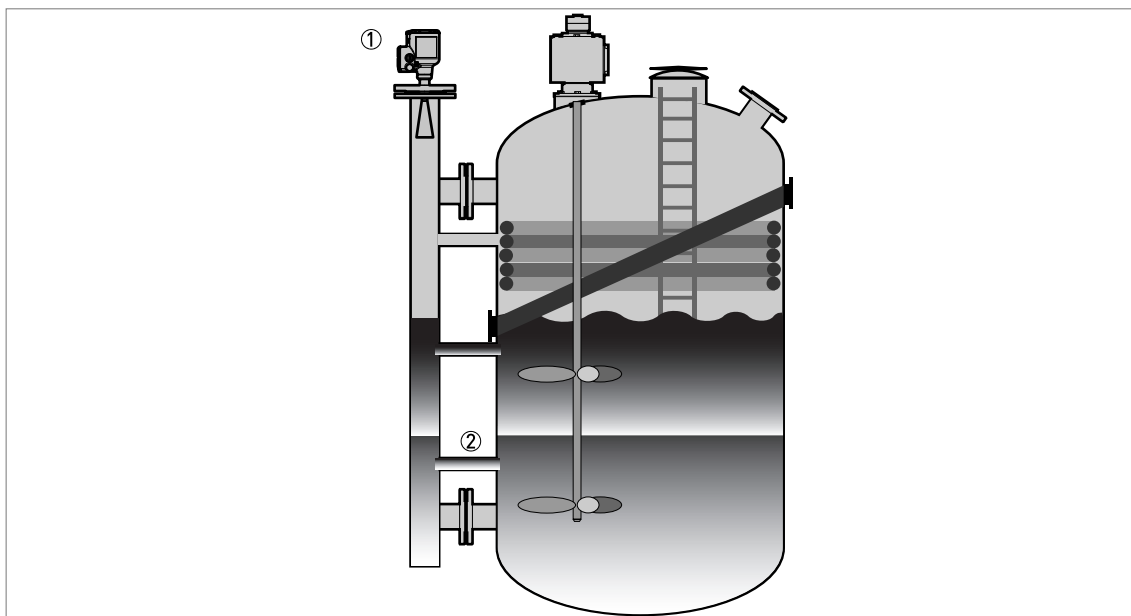

Figure 3-13: Installation recommendations for bypass chambers that contain more than one liquid

- ① Bypass chamber
- ② Additional process connection

4.1 Electrical installation: output options with cable gland

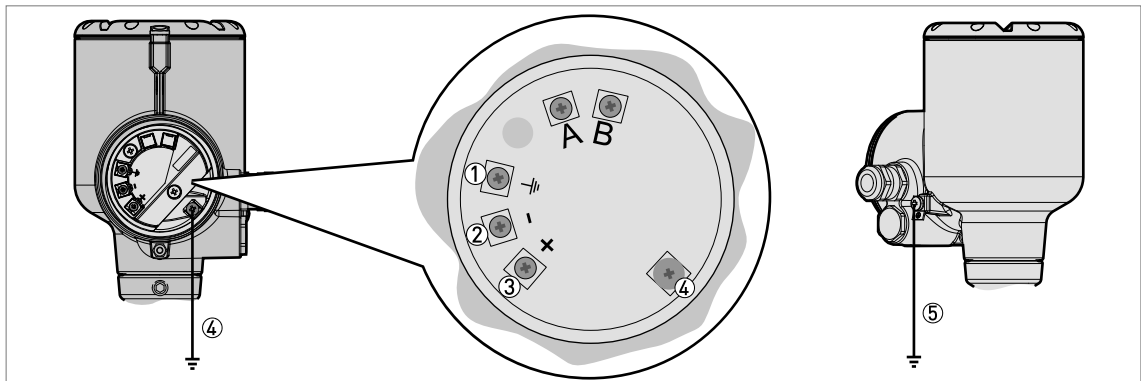

Figure 4-1: Terminals for electrical installation: standard cable gland

- ① Internal grounding terminal (for the shield wire)
- ② Current output -
- ③ Current output +
- ④ Internal grounding terminal
- ⑤ External grounding terminal

Electrical power to the output terminal energizes the device. The output terminal is also used for HART® communication.

If the device has the 4...20 mA output and HART® communication options, terminals A and B are not used.

4.2 Electrical installation: output options with an M12 male connector

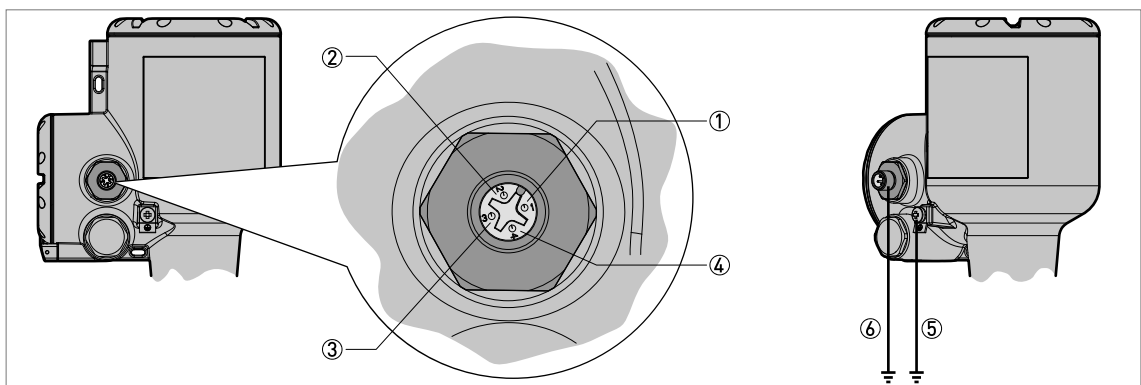

Figure 4-2: Terminals for electrical installation: 4-pin male M12 connector

- ① Pin 1: current output +
- ② Pin 2: not connected
- ③ Pin 3: current output -
- ④ Pin 4: not connected
- ⑤ Grounding terminal (external thread of the connector)
- ⑥ Location of the external grounding terminal (at the bottom of the converter)

Electrical power to the output terminal energizes the device. The output terminal is also used for HART® communication.

4.3 Non-Ex devices

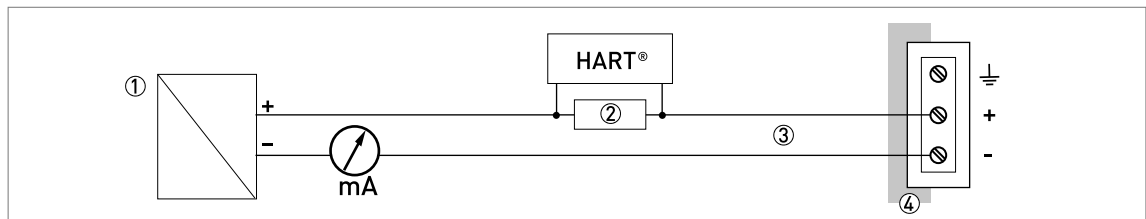

Figure 4-3: Electrical connections for non-Ex devices

- ① Power supply
- ② Resistor for HART® communication (typically 250 ohms)
- ③ Optional connection to the grounding terminal
- ④ Output: 12...30 V DC for a maximum output of 21.5 mA at the terminals
- ⑤ Device

4.4 Devices for hazardous locations

For electrical data for device operation in hazardous locations, refer to the related certificates of compliance and supplementary instructions (ATEX, IECEx etc.). This documentation can be downloaded from the website (Download Center).

4.5 Networks

4.5.1 General information

The device uses the HART® communication protocol. This protocol agrees with the HART® Communication Foundation standard. The device can be connected point-to-point. It can also have a polling address of 1 to 63 in a multi-drop network.

The device output is factory-set to communicate point-to-point. To change the communication mode from **point-to-point** to **multi-drop**, refer to "Network configuration" in the handbook.

4.5.2 Point-to-point connection

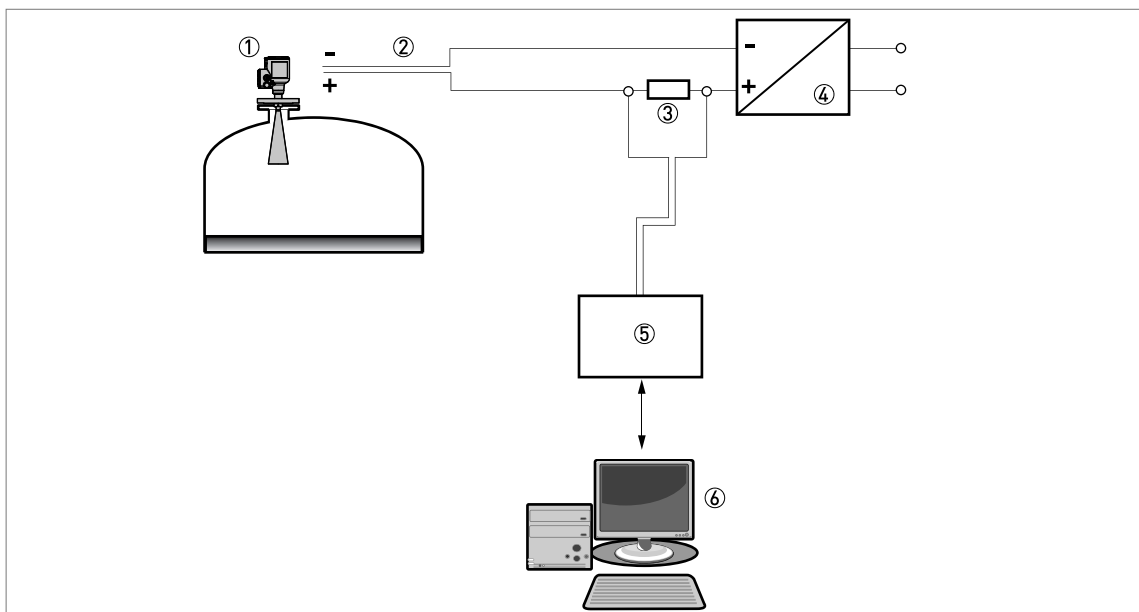

Figure 4-4: Point-to-point connection (non-Ex)

- ① Address of the device (0 for point-to-point connection)
- ② 4...20 mA + HART®
- ③ Resistor for HART® communication (typically 250 ohms)
- ④ Power supply
- ⑤ HART® converter
- ⑥ HART® communication software

4.5.3 Multi-drop networks

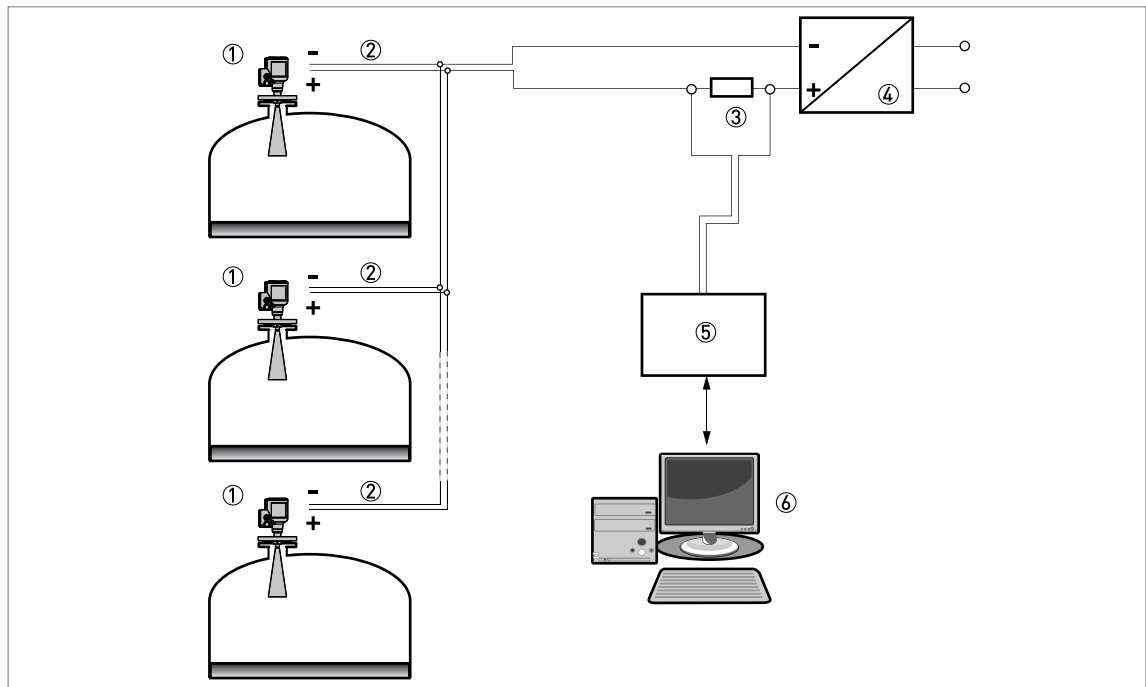
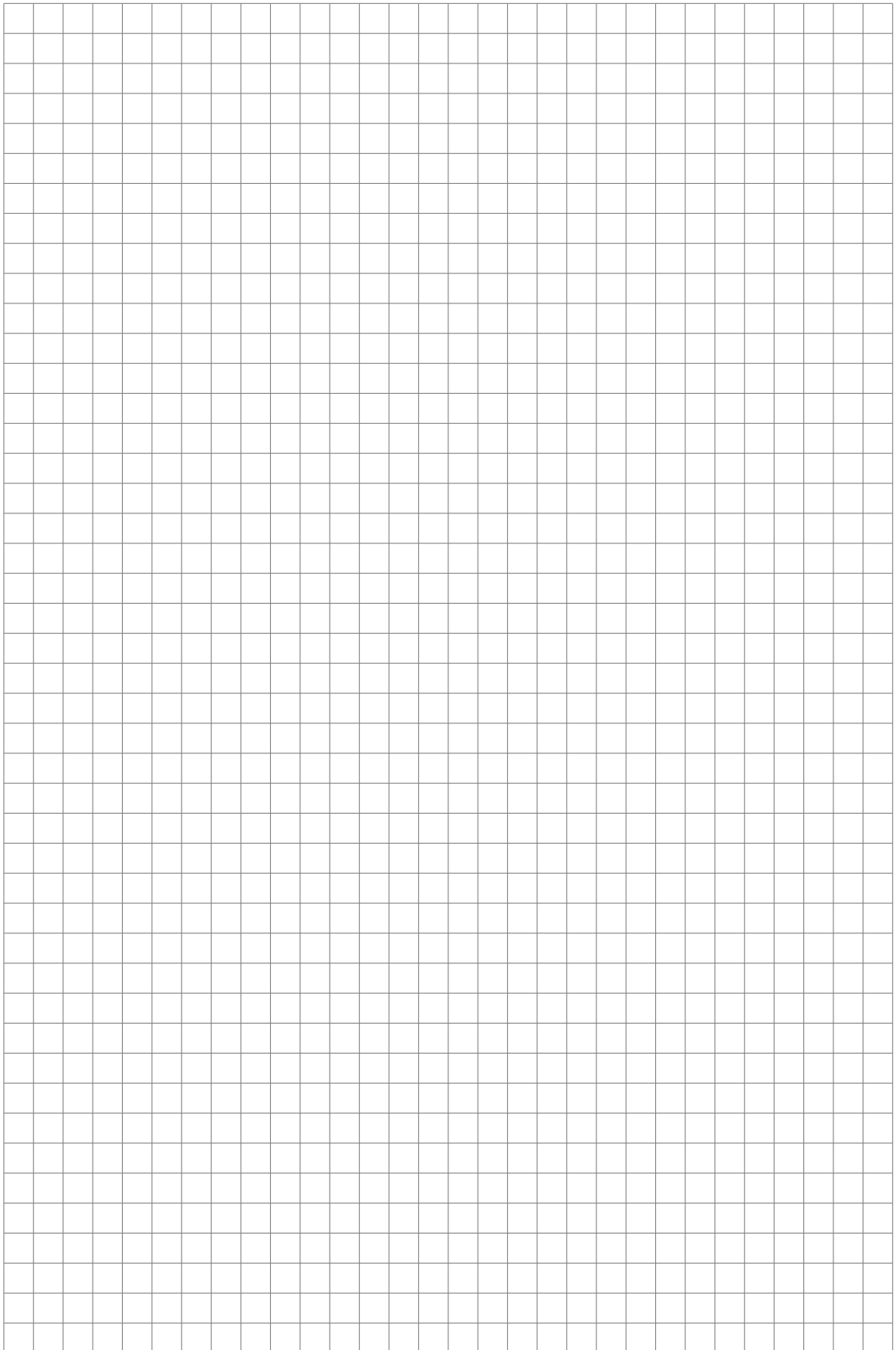

Figure 4-5: Multi-drop network (non-Ex)

- ① Address of the device (each device must have a different address in multi-drop networks)
- ② 4 mA + HART®
- ③ Resistor for HART® communication (typically 250 ohms)
- ④ Power supply
- ⑤ HART® converter
- ⑥ HART® communication software



KROHNE – Products, Solutions and Services

- Process instrumentation for flow, level, temperature, pressure measurement and process analytics
- Flow metering, monitoring, wireless and remote metering solutions
- Engineering, commissioning, calibration, maintenance and training services

Head Office KROHNE Messtechnik GmbH
Ludwig-Krohne-Str. 5
47058 Duisburg (Germany)
Tel.: +49 203 301 0
Fax: +49 203 301 10389
info@krohne.de

The current list of all KROHNE contacts and addresses can be found at:
www.krohne.com

