



OPTIFLEX 1100 C Handbook

Guided Radar (TDR) Level Meter

Continuous level measurement of liquids and solids

All rights reserved. It is prohibited to reproduce this documentation, or any part thereof, without the prior written authorisation of KROHNE Messtechnik GmbH.

Subject to change without notice.

Copyright 2012 by
KROHNE Messtechnik GmbH - Ludwig-Krohne-Str. 5 - 47058 Duisburg (Germany)

| | | |
|----------|---|-----------|
| 1 | Safety instructions | 6 |
| <hr/> | | |
| 1.1 | Intended use | 6 |
| 1.2 | Certification | 6 |
| 1.3 | Electromagnetic compatibility | 6 |
| 1.4 | Safety instructions from the manufacturer | 7 |
| 1.4.1 | Copyright and data protection | 7 |
| 1.4.2 | Disclaimer | 7 |
| 1.4.3 | Product liability and warranty | 8 |
| 1.4.4 | Information concerning the documentation | 8 |
| 1.4.5 | Warnings and symbols used | 9 |
| 1.5 | Safety instructions for the operator | 9 |
| | | |
| 2 | Device description | 10 |
| <hr/> | | |
| 2.1 | Device description | 10 |
| 2.2 | Nameplates | 10 |
| | | |
| 3 | Installation | 11 |
| <hr/> | | |
| 3.1 | Ø2 mm / 0.08" single cable probe (liquid applications) | 11 |
| 3.1.1 | Scope of delivery | 11 |
| 3.1.2 | Transport | 11 |
| 3.1.3 | How to assemble a single cable probe | 12 |
| 3.1.4 | Mounting position | 13 |
| 3.1.5 | Installation in standpipes (stilling wells and bypass chambers) | 14 |
| 3.1.6 | Horizontal cylindrical tanks | 15 |
| 3.2 | Coaxial probe (low-viscosity liquid applications) | 16 |
| 3.2.1 | Scope of delivery | 16 |
| 3.2.2 | Transport | 16 |
| 3.2.3 | How to assemble the segmented coaxial probe | 17 |
| 3.2.4 | Mounting position | 21 |
| 3.3 | Ø4 mm / 0.15" single cable probe (solid applications) | 22 |
| 3.3.1 | Scope of delivery | 22 |
| 3.3.2 | Transport | 22 |
| 3.3.3 | How to assemble a single cable probe | 23 |
| 3.3.4 | Mounting position | 26 |
| 3.4 | How to install a device with a threaded connection | 27 |
| 3.5 | Recommendations for pits and tanks made of non-conductive materials | 27 |
| 3.6 | How to turn or remove the signal converter | 28 |
| | | |
| 4 | Electrical connections | 29 |
| <hr/> | | |
| 4.1 | Safety instructions | 29 |
| 4.2 | Electrical installation: 2-wire, loop-powered | 29 |
| 4.3 | Protection category | 31 |
| 4.4 | How to attach the optional display unit to the device | 32 |

| | |
|---|----|
| 5 Start-up | 35 |
| 5.1 How to start the device | 35 |
| 5.1.1 Start-up checklist | 35 |
| 5.1.2 How to start the device | 35 |
| 5.2 Digital display screen (option) | 36 |
| 6 Operation | 37 |
| 6.1 User modes | 37 |
| 6.2 Normal mode | 37 |
| 6.3 Configuration mode | 37 |
| 6.3.1 General notes | 37 |
| 6.3.2 Menu overview | 38 |
| 6.3.3 Function description | 38 |
| 6.4 Further information on device configuration | 44 |
| 6.4.1 Quick Setup | 44 |
| 6.4.2 Test | 46 |
| 6.4.3 Protection of the device settings | 47 |
| 6.4.4 Distance measurement | 48 |
| 6.4.5 Level measurement | 49 |
| 6.4.6 How to configure the device to measure volume or mass | 49 |
| 6.4.7 Thresholds and parasitic signals | 51 |
| 6.5 Status and error messages | 53 |
| 6.5.1 Status markers | 53 |
| 6.5.2 Error handling | 54 |
| 7 Service | 56 |
| 7.1 Spare parts availability | 56 |
| 7.1.1 Part numbers for spare parts and accessories | 56 |
| 7.2 Availability of services | 57 |
| 7.3 Repairs | 57 |
| 7.4 Returning the device to the manufacturer | 58 |
| 7.4.1 General information | 58 |
| 7.4.2 Form (for copying) to accompany a returned device | 59 |
| 7.5 Disposal | 59 |
| 8 Technical data | 60 |
| 8.1 Measuring principle | 60 |
| 8.2 Technical data | 61 |
| 8.3 Minimum power supply voltage | 63 |
| 8.4 Measurement limits | 64 |
| 8.5 Dimensions and weights | 65 |

| | |
|----------------------|----|
| 9 Appendix | 67 |
| 9.1 Order code | 67 |
| 9.2 Glossary | 68 |
| 10 Notes | 71 |

1.1 Intended use

**CAUTION!**

Responsibility for the use of the measuring devices with regard to suitability, intended use and corrosion resistance of the used materials against the measured fluid lies solely with the operator.

**INFORMATION!**

The manufacturer is not liable for any damage resulting from improper use or use for other than the intended purpose.

This TDR level transmitter has 3 probe versions:

Ø2 mm single cable probe

This device measures distance and level of liquids, pastes and slurries with a viscosity less than 10000 mPa.s. It can be installed on tanks.

Segmented coaxial probe

This device measures distance and level of liquids with a viscosity less than 500 mPa.s. It can be installed on tanks and open pits.

Ø4 mm single cable probe

This device measures distance and level of granulates and powders.

1.2 Certification



In accordance with the commitment to customer service and safety, the device described in this document meets the following safety requirements:

- Electromagnetic Compatibility (EMC) Directive 2004/108/EC in conjunction with EN 61326-1 (2006) and EN 61326-2-3 (2006)

1.3 Electromagnetic compatibility

The device design agrees with European Standard EN 61326-1 when installed in metallic tanks.

You can install the device on open-air tanks and tanks that are not made of metal. This agrees with Emissions requirements for industrial environments (class A). For data on Immunity requirements, refer to the note that follows.

**CAUTION!**

If you install a device with a cable probe in a non-metallic tank or open-air pit, a strong electromagnetic field near to the device can have an unwanted effect on the accuracy. Use a device with a coaxial probe for this type of installation.

**INFORMATION!**

Device operation agrees with residential-class (class B) emissions and industrial-class for immunity requirements if the time constant (menu item 2.3.2 TIME CONST.) ≥ 3 seconds and:

- *the device has a single cable probe and is used in a closed tank made of metal or*
- *the device has a coaxial probe.*

1.4 Safety instructions from the manufacturer

1.4.1 Copyright and data protection

The contents of this document have been created with great care. Nevertheless, we provide no guarantee that the contents are correct, complete or up-to-date.

The contents and works in this document are subject to copyright. Contributions from third parties are identified as such. Reproduction, processing, dissemination and any type of use beyond what is permitted under copyright requires written authorisation from the respective author and/or the manufacturer.

The manufacturer tries always to observe the copyrights of others, and to draw on works created in-house or works in the public domain.

The collection of personal data (such as names, street addresses or e-mail addresses) in the manufacturer's documents is always on a voluntary basis whenever possible. Whenever feasible, it is always possible to make use of the offerings and services without providing any personal data.

We draw your attention to the fact that data transmission over the Internet (e.g. when communicating by e-mail) may involve gaps in security. It is not possible to protect such data completely against access by third parties.

We hereby expressly prohibit the use of the contact data published as part of our duty to publish an imprint for the purpose of sending us any advertising or informational materials that we have not expressly requested.

1.4.2 Disclaimer

The manufacturer will not be liable for any damage of any kind by using its product, including, but not limited to direct, indirect or incidental and consequential damages.

This disclaimer does not apply in case the manufacturer has acted on purpose or with gross negligence. In the event any applicable law does not allow such limitations on implied warranties or the exclusion of limitation of certain damages, you may, if such law applies to you, not be subject to some or all of the above disclaimer, exclusions or limitations.

Any product purchased from the manufacturer is warranted in accordance with the relevant product documentation and our Terms and Conditions of Sale.

The manufacturer reserves the right to alter the content of its documents, including this disclaimer in any way, at any time, for any reason, without prior notification, and will not be liable in any way for possible consequences of such changes.

1.4.3 Product liability and warranty

The operator shall bear responsibility for the suitability of the device for the specific purpose. The manufacturer accepts no liability for the consequences of misuse by the operator. Improper installation and operation of the devices (systems) will cause the warranty to be void. The respective "Standard Terms and Conditions" which form the basis for the sales contract shall also apply.

1.4.4 Information concerning the documentation

To prevent any injury to the user or damage to the device it is essential that you read the information in this document and observe applicable national standards, safety requirements and accident prevention regulations.

If this document is not in your native language and if you have any problems understanding the text, we advise you to contact your local office for assistance. The manufacturer can not accept responsibility for any damage or injury caused by misunderstanding of the information in this document.

This document is provided to help you establish operating conditions, which will permit safe and efficient use of this device. Special considerations and precautions are also described in the document, which appear in the form of underneath icons.

1.4.5 Warnings and symbols used

Safety warnings are indicated by the following symbols.



DANGER!

This information refers to the immediate danger when working with electricity.



DANGER!

This warning refers to the immediate danger of burns caused by heat or hot surfaces.



DANGER!

This warning refers to the immediate danger when using this device in a hazardous atmosphere.



DANGER!

These warnings must be observed without fail. Even partial disregard of this warning can lead to serious health problems and even death. There is also the risk of seriously damaging the device or parts of the operator's plant.



WARNING!

Disregarding this safety warning, even if only in part, poses the risk of serious health problems. There is also the risk of damaging the device or parts of the operator's plant.



CAUTION!

Disregarding these instructions can result in damage to the device or to parts of the operator's plant.



INFORMATION!

These instructions contain important information for the handling of the device.



LEGAL NOTICE!

This note contains information on statutory directives and standards.



• **HANDLING**

This symbol designates all instructions for actions to be carried out by the operator in the specified sequence.

➔ **RESULT**

This symbol refers to all important consequences of the previous actions.

1.5 Safety instructions for the operator



WARNING!

*In general, devices from the manufacturer may only be installed, commissioned, operated and maintained by properly trained and authorized personnel.
This document is provided to help you establish operating conditions, which will permit safe and efficient use of this device.*

2.1 Device description

TDR level meters are designed exclusively to measure the distance and level of liquids, pastes, slurries, powders and granulates.

Your measuring device is supplied with a standard length of probe. If the probe length is larger than the tank height, you must adjust the length of the probe to the tank height before operation. A quick set-up procedure permits the device to operate correctly with the new probe length.

The following versions are available:

- Compact version with Ø2 mm / 0.08" single cable probe (for liquids)
- Compact version with coaxial probe (for liquids, maximum viscosity 500 mPa.s / 0.028 lb/in.s)
- Compact version with Ø4 mm / 0.15" single cable probe (for solids)

2.2 Nameplates



INFORMATION!

Look at the device nameplate to ensure that the device is delivered according to your order. Check for the correct supply voltage printed on the nameplate.

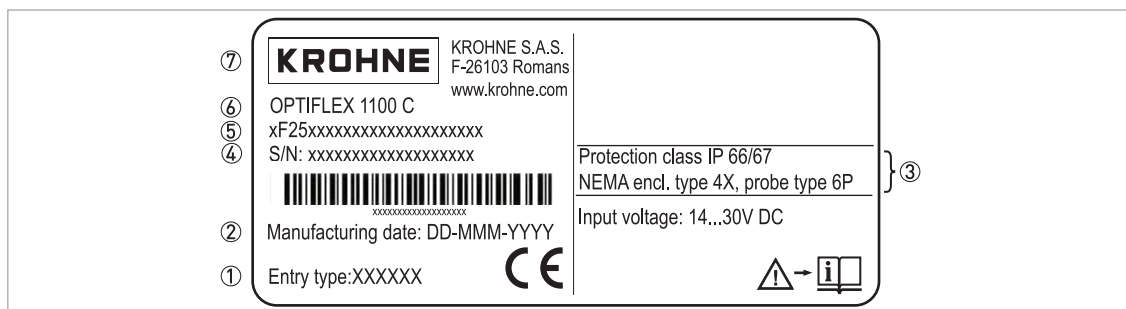

Figure 2-1: Nameplate

- ① Cable entry size
- ② Date of manufacture
- ③ Degree of ingress protection (according to EN 60529 / IEC 60529)
- ④ Order number
- ⑤ Type code (defined in order)
- ⑥ Model name and number
- ⑦ Company name and address

3.1 Ø2 mm / 0.08" single cable probe (liquid applications)

3.1.1 Scope of delivery



INFORMATION!

Do a check of the packing list to make sure that you have all the elements given in the order.

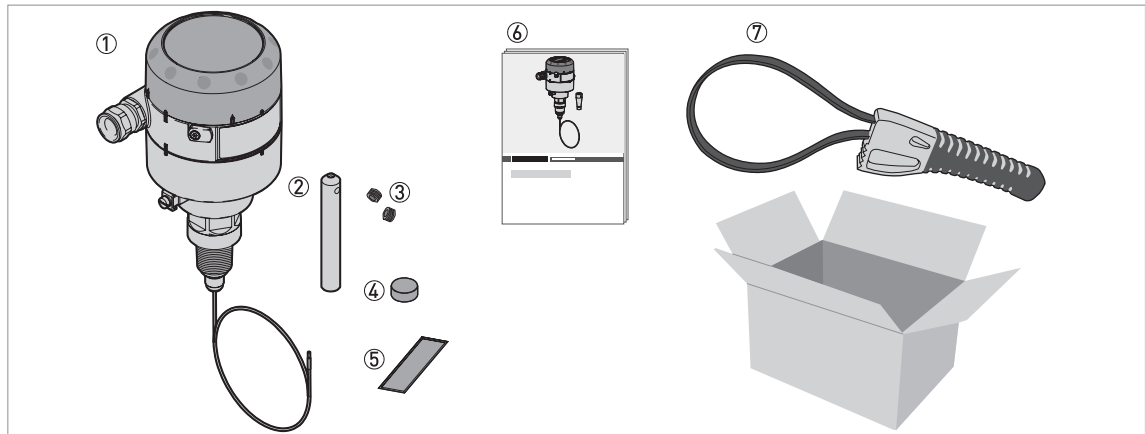

Figure 3-1: Scope of delivery: device with Ø2 mm single cable probe option

- ① Converter, process connection and probe
- ② Counterweight
- ③ 2 HC M6x5 screws for the counterweight
- ④ Probe assembly cover. For more data, refer to *How to turn or remove the signal converter* on page 28.
- ⑤ Sticker: if you adjust the probe length, write the new value on the sticker
- ⑥ Quick Start
- ⑦ Strap wrench

3.1.2 Transport

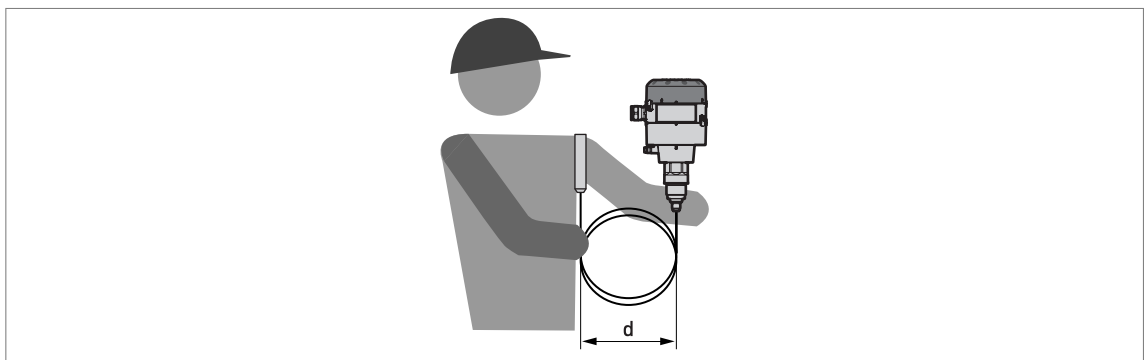
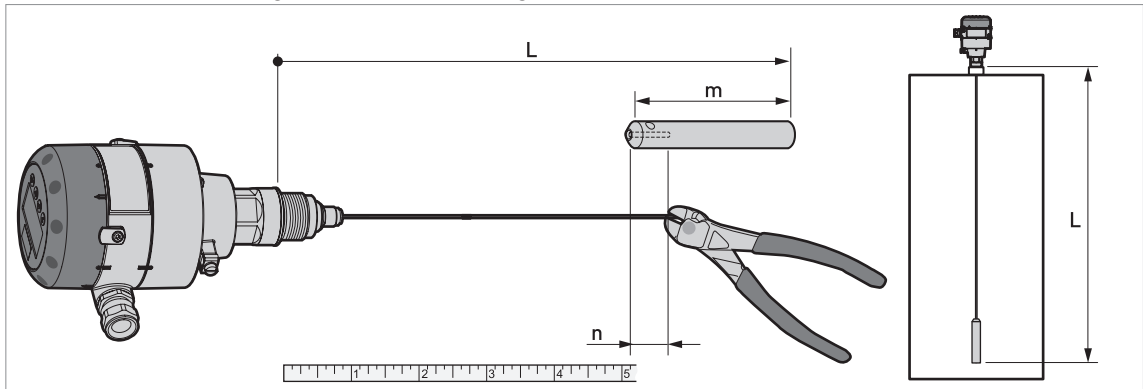

Figure 3-2: How to hold the device

$d > 100 \text{ mm} / 4''$

3.1.3 How to assemble a single cable probe

Adjust the probe length to the tank height

Figure 3-3: How to assemble the $\varnothing 2$ mm / 0.08" single cable probe: part 1

L = Probe length (thread stop to the bottom of the counterweight)

m = Counterweight length = 100 mm / 4"

n = Cable insertion length = 15 mm / 0.6"

**INFORMATION!**

The single cable probe measures between the top of the counterweight and the thread stop on the process connection.



- Measure the probe.
- ➔ Make sure that you include the length of the counterweight (m) minus the cable insertion length (n).
- Mark the probe length necessary for your application on the cable.
- Cut the cable.

Attach the counterweight

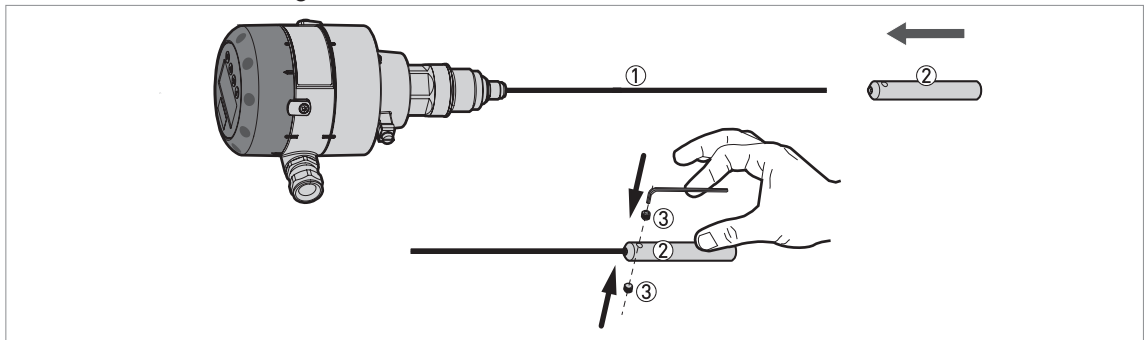

Figure 3-4: How to assemble the single cable probe: part 2

- ① Single cable probe
- ② Counterweight
- ③ 2 HC M6x5 lock screws



CAUTION!

Make sure the cable is fully engaged in the probe counterweight.



- Attach the counterweight.
- Attach the lock screws to the counterweight. Tighten with a 3 mm Allen wrench.
- ➡ The device is prepared for installation on the tank.

If you decreased the probe length, you must enter the new value in the device configuration menu (NOTE: the device must have the LCD display option or the HMI service tool). For more data, refer to *Quick Setup* on page 44.

3.1.4 Mounting position

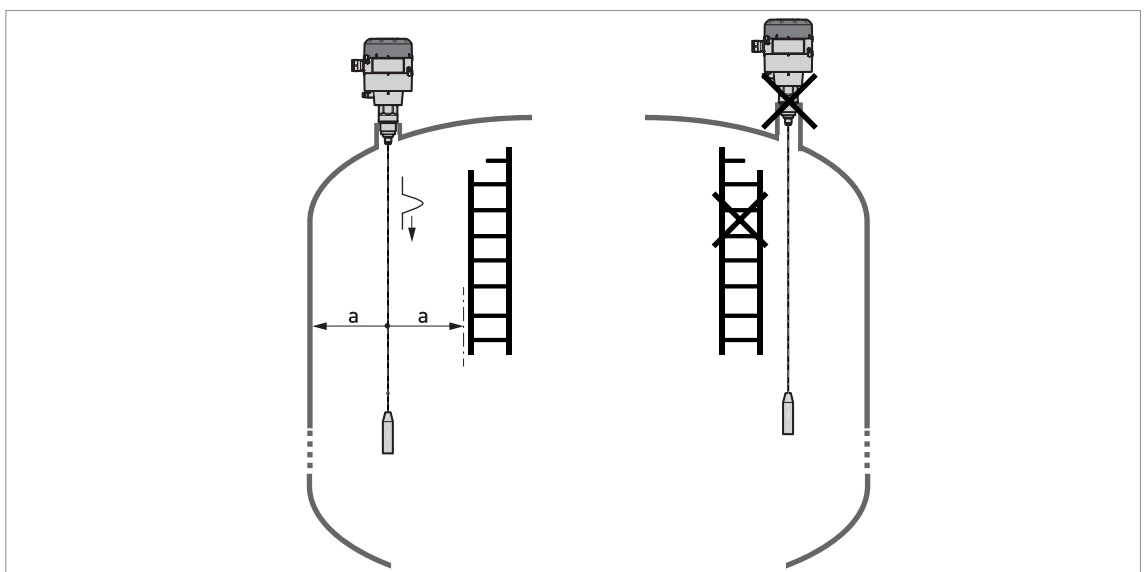

Figure 3-5: Cable probe: minimum distance from metallic walls and other metal objects

$a \geq 300 \text{ mm} / 12''$

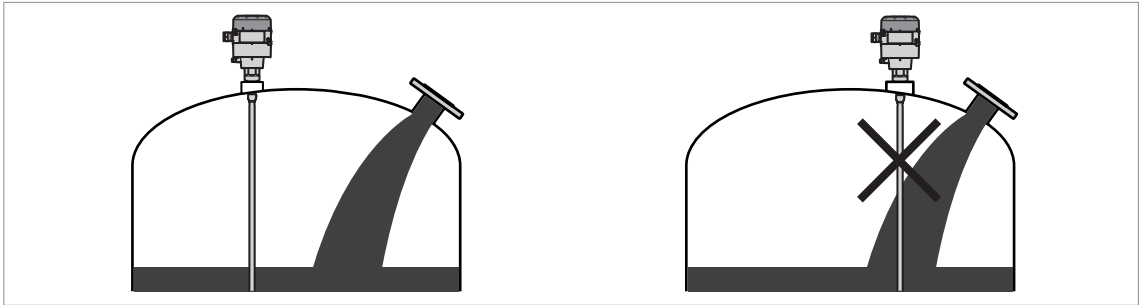

Figure 3-6: Do not install the probe near to a product inlet

3.1.5 Installation in standpipes (stilling wells and bypass chambers)

Use a standpipe if there are too many other objects in the tank or the liquid is turbulent.

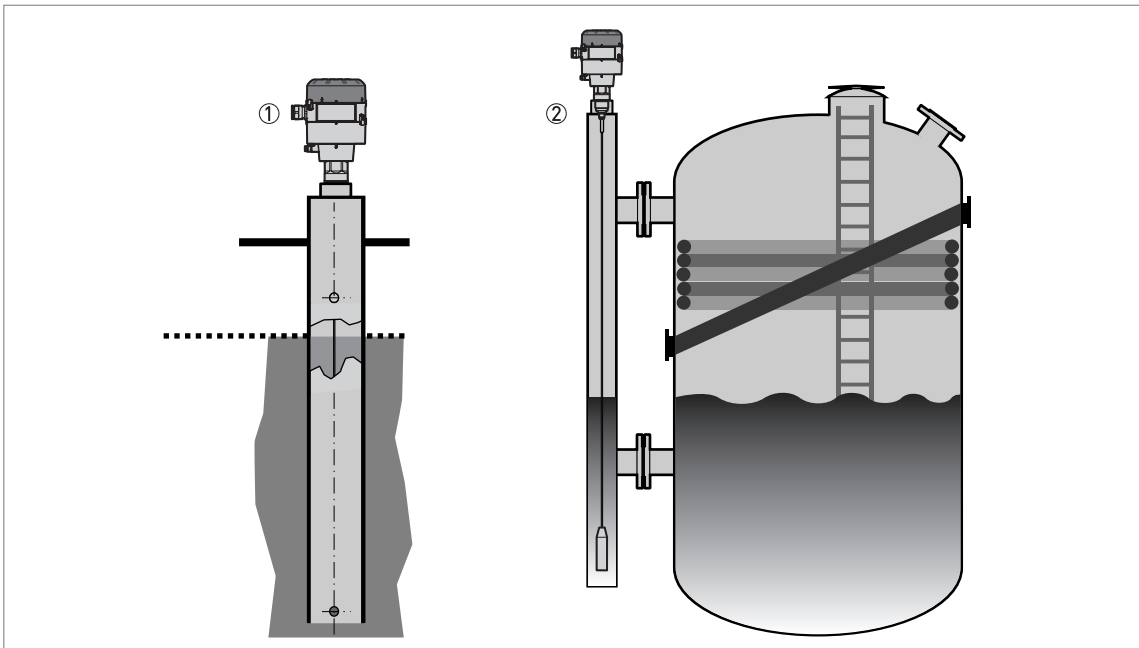

Figure 3-7: Installation recommendations for standpipes (stilling wells and bypass chambers)

- ① Stilling well
- ② Bypass chamber



INFORMATION!

Stilling wells are not necessary for devices with coaxial probes. But if there is a sudden change in diameter in the stilling well, we recommend that you install a device with a coaxial probe.

**CAUTION!****Installation requirements**

- The standpipe must be made of metal.
- The standpipe must be straight. There must be no changes in diameter from the device process connection to the bottom of the standpipe.
- The standpipe must be vertical.
- Recommended surface roughness: $<\pm 0.1 \text{ mm} / <\pm 0.004''$.
- Stilling well only: The bottom of the stilling well must be open.
- Adjust the probe to the center of the standpipe.
- Make sure that there are no deposits at the bottom of the standpipe which can cause blockage of the process connections.
- Make sure that there is liquid in the standpipe.

Stilling wells**Installation in tanks that contain one liquid**

- Make sure that the stilling well has a vent above the maximum level.
- If the probe has a counterweight, make sure that there is enough space between the counterweight and the wall of the stilling well.

Bypass chambers**Installation next to tanks that contain one liquid**

- The bypass chamber must have a process connection that is above the maximum level of liquid.
- The bypass chamber must have a process connection that is below the lowest measured level of liquid.

3.1.6 Horizontal cylindrical tanks

The installation requirements and procedures for vertical tanks are also applicable to horizontal cylindrical tanks.

**CAUTION!**

Calculate volume and mass values carefully for the strapping table. Volume does not increase in the same proportion as level.

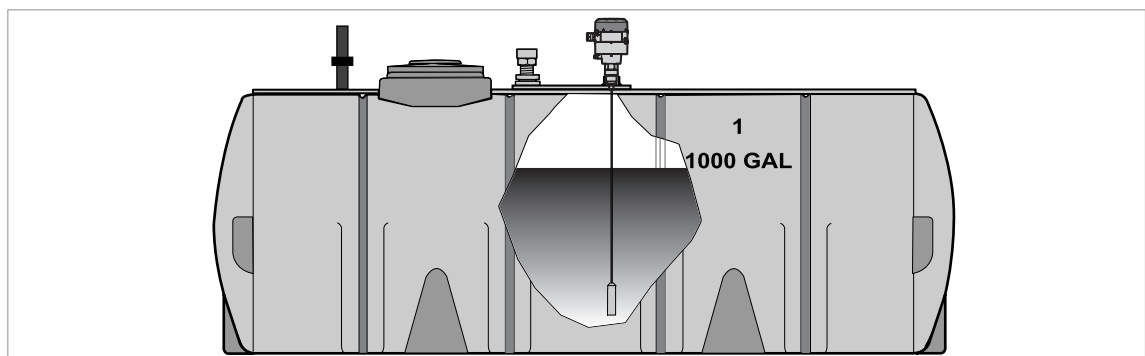

Figure 3-8: How to install the device in a horizontal cylindrical tank

3.2 Coaxial probe (low-viscosity liquid applications)

3.2.1 Scope of delivery



INFORMATION!

Do a check of the packing list to make sure that you have all the elements given in the order.

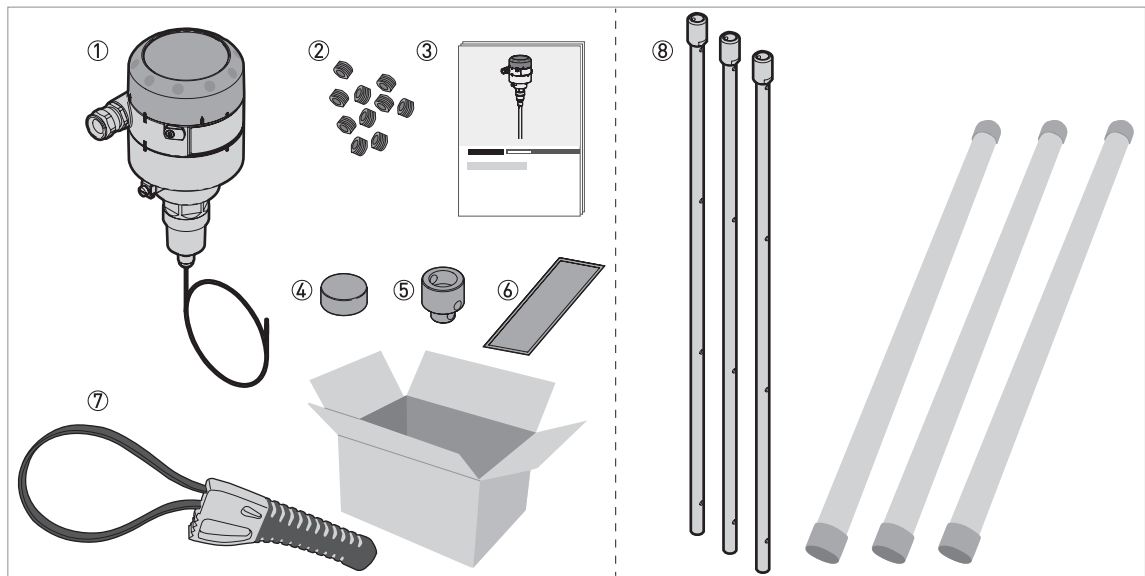

Figure 3-9: Scope of delivery: device with coaxial probe option

- ① Converter, process connection and signal cable
- ② HC M6x5 screws (1 screw per segment of tube, 3 screws for the last segment - supplied in a plastic sachet)
- ③ Quick Start
- ④ Probe assembly cover. For more data, refer to *How to turn or remove the signal converter* on page 28.
- ⑤ Probe end cap
- ⑥ Sticker: if you adjust the probe length, write the new value on the sticker
- ⑦ Strap wrench
- ⑧ Disassembled segments of tube

3.2.2 Transport

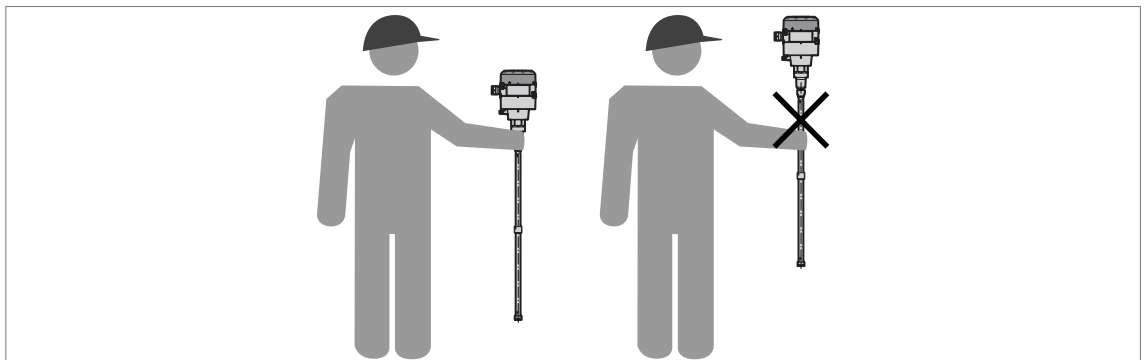

Figure 3-10: How to hold the device

3.2.3 How to assemble the segmented coaxial probe

Attach the tube segments

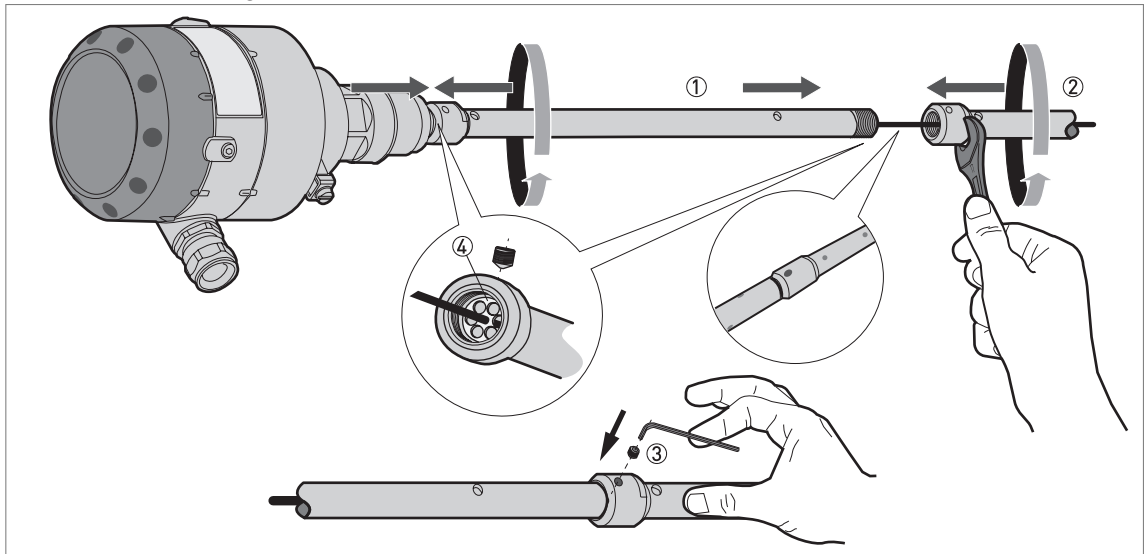

Figure 3-11: How to assemble the segmented coaxial probe: part 1

- ① Top segment of tube
- ② Bottom segment of tube
- ③ 1 HC M6×5 lock screw
- ④ Bonded plastic spacer



CAUTION!

- After you tighten the lock screw on each segment of tube, it will not be possible to disassemble the coaxial probe.
- If it is necessary to adjust the probe length, do not attach the lock screw to the last segment of tube!



- Put the signal cable into the first segment of tube. Make sure that the signal cable goes through the center hole in the spacer.
- Attach the first segment of tube to the thread at the top of the signal cable. Tighten with a 17 mm open-end wrench.
- Attach the lock screw to the top of the tube. Tighten with a 3 mm Allen wrench.
- Do these steps again for each segment of tube, but do not attach the lock screw to the last segment of tube.

Adjust the probe length to the tank height

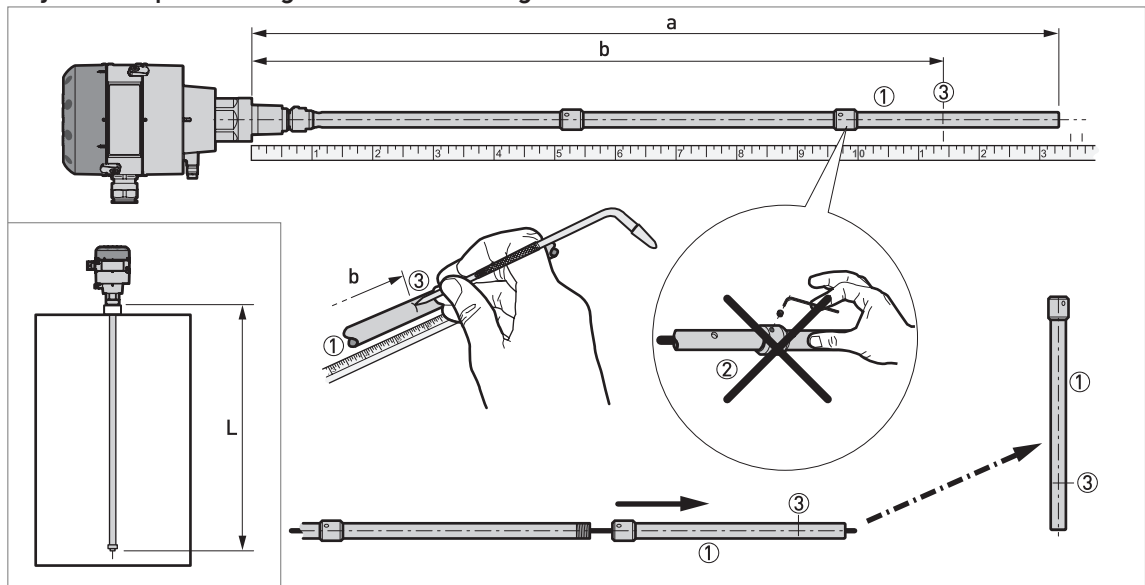

Figure 3-12: How to assemble the segmented coaxial probe: part 2

a = Delivered probe length (with all segments attached, but without the probe end cap)

b = Length of tube needed = total probe length, L - 15 mm / 0.6"

① Coaxial probe: Last segment of the tube

② Do not attach the lock screw to the last segment of tube! Make sure that the coaxial probe is the correct length for the tank.

③ Scriber mark - to cut the tube to the correct length

**CAUTION!**

If it is necessary to decrease the length of the probe, do not attach the lock screw on the last segment of tube.

Make sure the probe is the correct length for the tank. Add the probe end cap length (15 mm / 0.6") to get the total length of the probe.



- Measure the probe (with all the segments attached).
- Mark the probe length necessary for your application on the tube.
- Remove the last segment of tube.

Adjust the probe length to the tank height

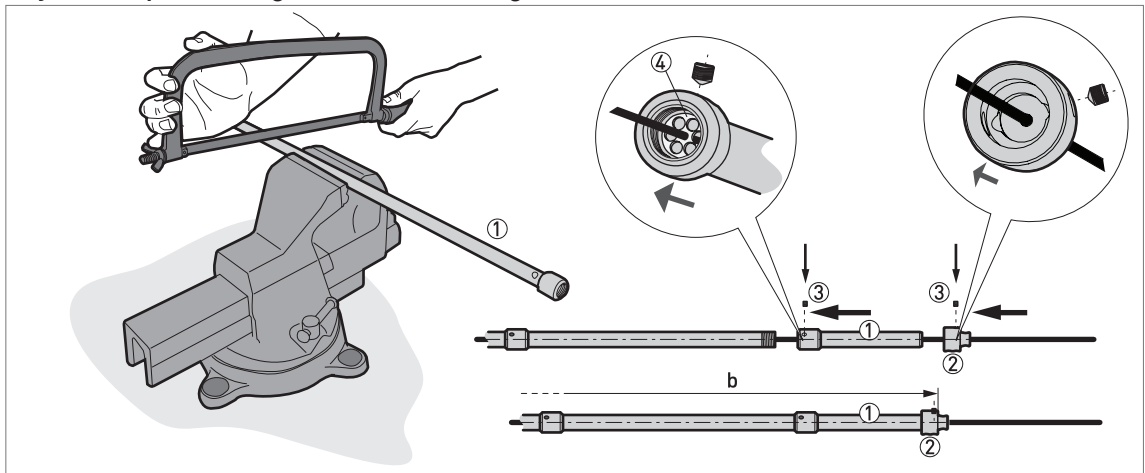

Figure 3-13: How to assemble the segmented coaxial probe

- ① Coaxial probe: Last segment of the tube
- ② Probe end cap
- ③ 1 HC M6x5 lock screw
- ④ Bonded plastic spacer

**CAUTION!**

Before you cut the tube, disassemble the last segment of tube from the coaxial probe and remove the signal cable.

After you tighten the lock screw, it will not be possible to disassemble the coaxial probe.



- Cut the last segment of tube.
- Attach the last segment of tube.
- Attach the probe end cap ② to the end of the tube. Tighten lock screw ③ with a 3 mm Allen wrench.

Make sure that the tension in the signal cable is correct

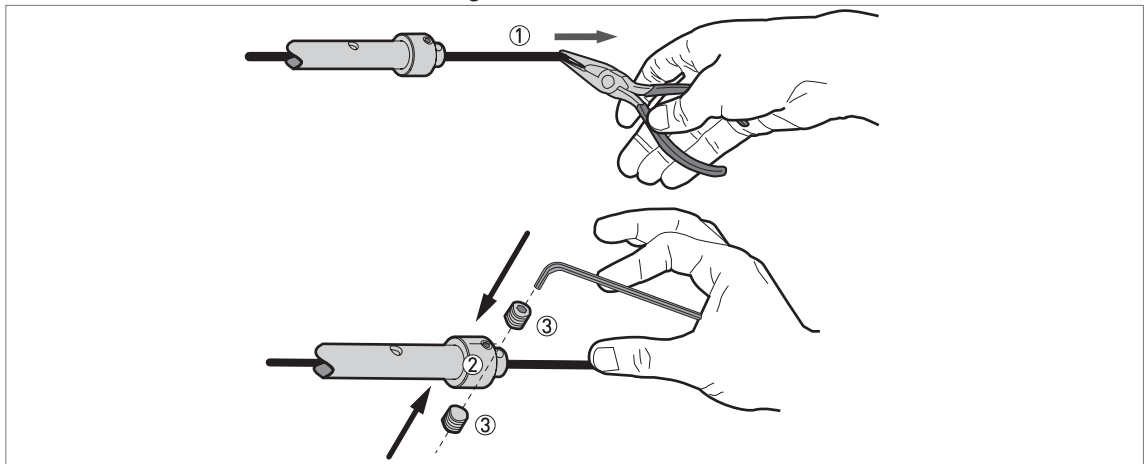

Figure 3-14: How to assemble the segmented coaxial probe: part 4

- ① Coaxial probe: Signal cable
- ② Coaxial probe: Probe end cap
- ③ 2 HC M6x5 screws



- Pull the signal cable from the bottom of the last segment of tube. Apply 10 kgf / 22 lbf.
- Attach the screws for the signal cable to the probe end cap. Tighten with a 3 mm Allen wrench.

Cut the signal cable to the correct length

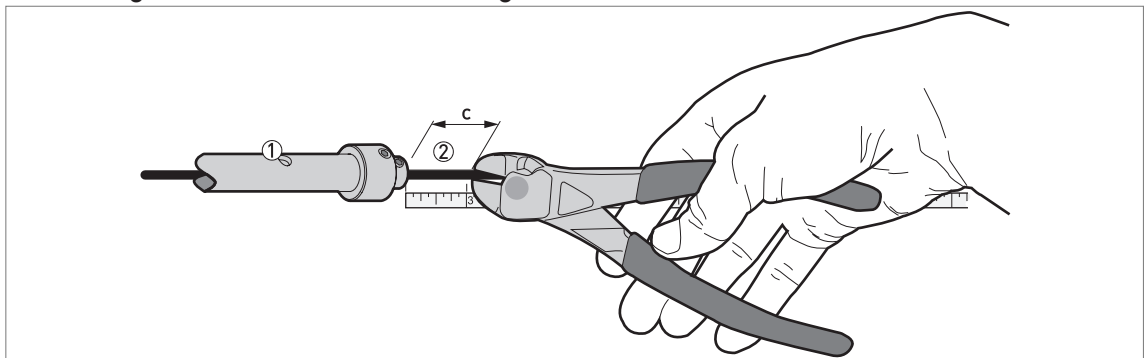

Figure 3-15: How to assemble the segmented coaxial probe: part 5

$c = 20 \text{ mm} / 0.8''$

- ① Coaxial probe: bottom of the last segment of tube
- ② Coaxial probe: signal cable



- Cut the signal cable 20 mm / 0.8" below the last segment of tube.
- ➡ The device is prepared for installation on the tank.

If you decreased the probe length, you must enter the new probe length in the device configuration menu (NOTE: the device must have the LCD display option or the HMI service tool). For more data, refer to *Quick Setup* on page 44.

3.2.4 Mounting position

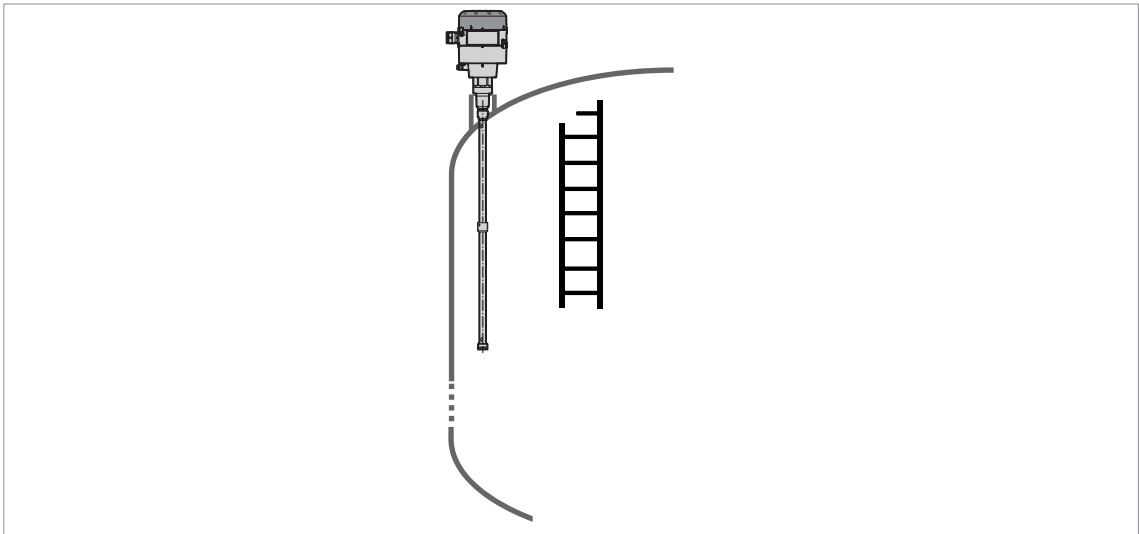

Figure 3-16: Coaxial probe: minimum distance from metallic walls and other metal objects

There is no minimum distance from the coaxial probe to metallic walls and other metal objects.

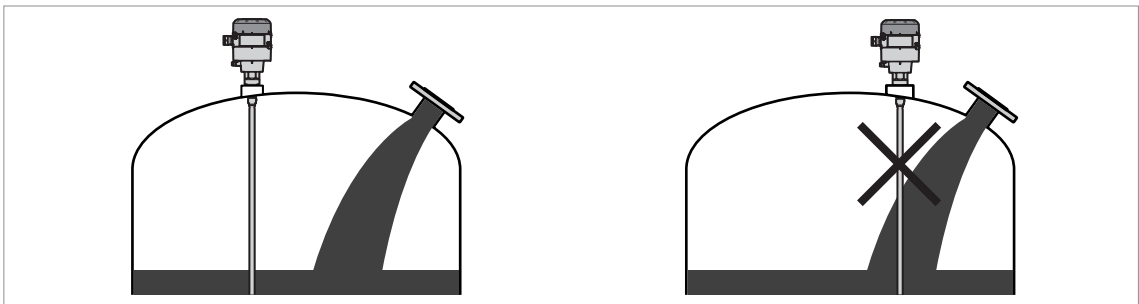

Figure 3-17: Do not install the probe near to a product inlet

3.3 Ø4 mm / 0.15" single cable probe (solid applications)

3.3.1 Scope of delivery



INFORMATION!

Do a check of the packing list to make sure that you have all the elements given in the order.

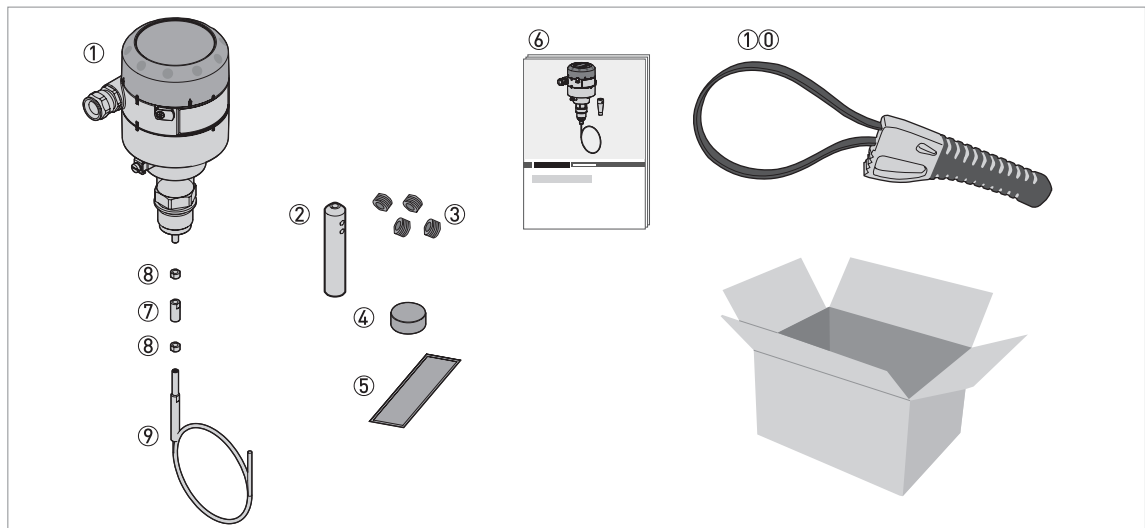

Figure 3-18: Scope of delivery: device with Ø4 mm single cable probe option

- ① Converter and process connection
- ② Counterweight
- ③ 4 HC M6×5 screws for the counterweight
- ④ Probe assembly cover. For more data, refer to *How to turn or remove the signal converter* on page 28.
- ⑤ Sticker: if you adjust the probe length, write the new value on the sticker
- ⑥ Quick Start
- ⑦ Union nut
- ⑧ 2 lock nuts
- ⑨ Probe
- ⑩ Strap wrench

3.3.2 Transport

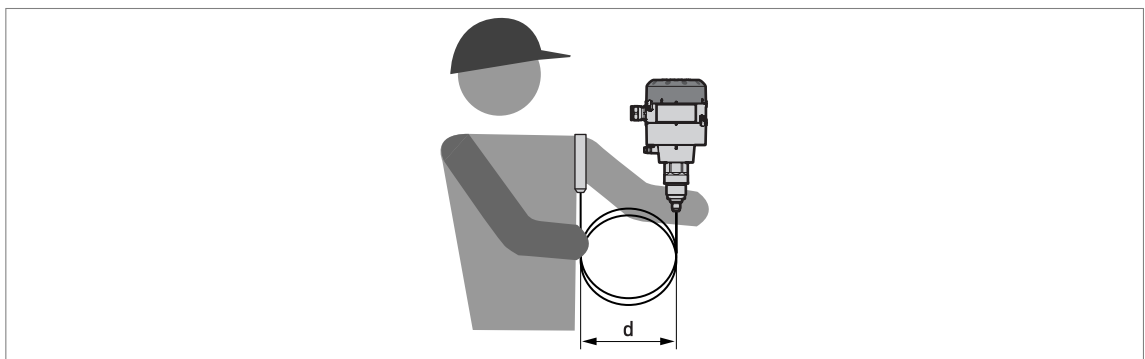

Figure 3-19: How to hold the device

$d > 100 \text{ mm} / 4''$

3.3.3 How to assemble a single cable probe

Attach the probe to the converter

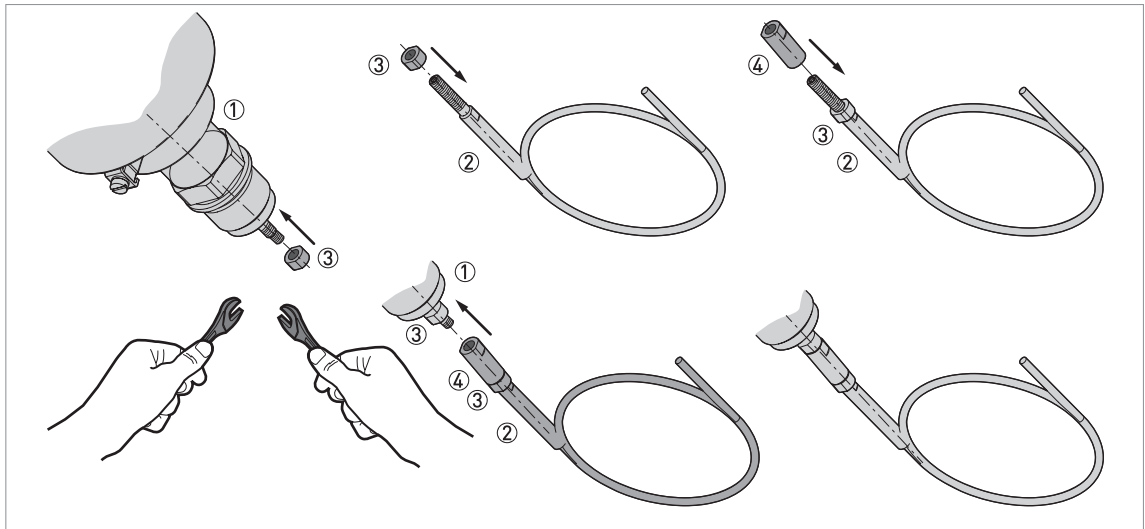

Figure 3-20: How to assemble the Ø4 mm / 0.15" single cable probe: part 1

- ① Converter and process connection
- ② Probe
- ③ Lock nut
- ④ Union nut



- Attach a lock nut ③ to the fitting below the process connection ①.
- Attach a lock nut ③ to the fitting at the top of the probe ②.
- Attach the union nut ④ to the fitting at the top of the probe. Use two 8 mm wrenches to tighten the lock nut and union nut.
- Use the union nut to attach the probe to the fitting below the process connection. Use two 8 mm wrenches to tighten the top lock nut and union nut.

Adjust the probe length to the tank height

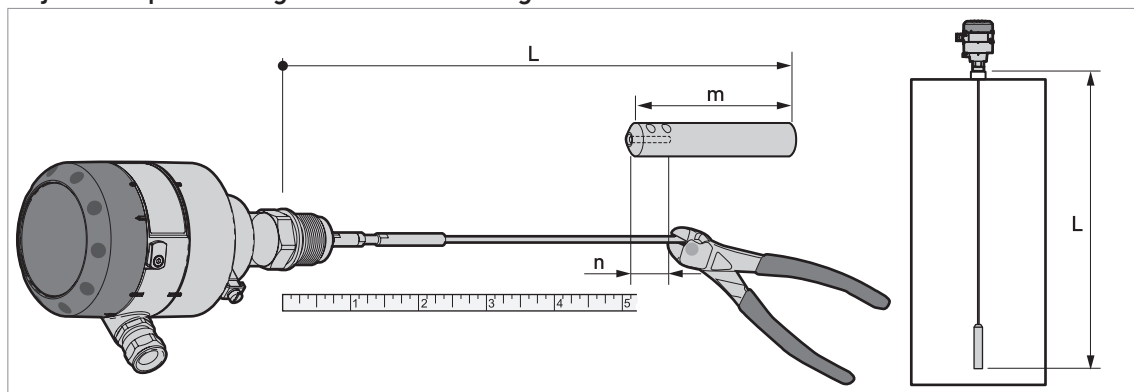
Figure 3-21: How to assemble the $\varnothing 4$ mm / 0.15" single cable probe: part 2

L = Probe length (thread stop to the bottom of the counterweight)

m = Counterweight length = 100 mm / 4"

n = Cable insertion length = 36 mm / 1.4"



- Measure the probe.
- ➔ Make sure that you include the length of the counterweight (m) minus the cable insertion length (n).
- Mark the probe length necessary for your application on the cable.
- Cut the cable.

Attach the counterweight

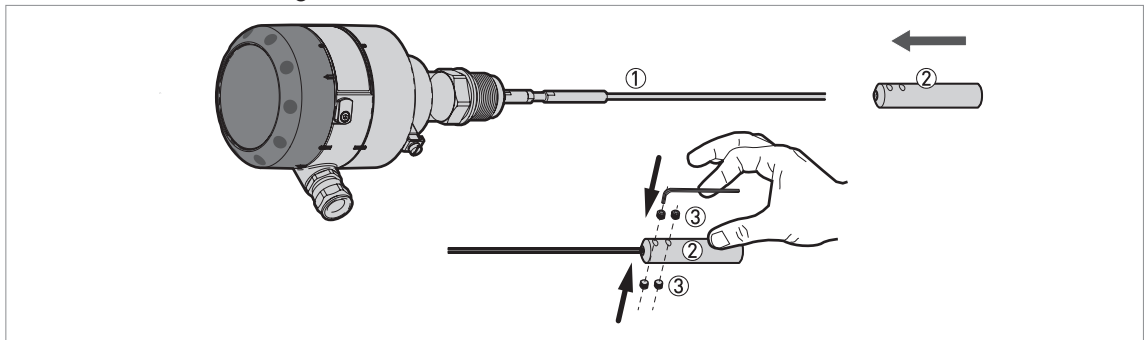

Figure 3-22: How to assemble the Ø4 mm / 0.15" single cable probe: part 3

- ① Single cable probe
- ② Counterweight
- ③ 4 HC M6x5 lock screws



CAUTION!

Make sure the cable is fully engaged in the probe counterweight.



- Attach the counterweight.
- Attach the lock screws to the counterweight. Tighten with a 3 mm Allen wrench.
- ➔ The device is prepared for installation on the tank.

If you decreased the probe length, you must enter the new probe length in the device configuration menu (NOTE: the device must have the LCD display option or the HMI service tool). For more data, refer to *Quick Setup* on page 44.

3.3.4 Mounting position

We recommend that you install the probe when the silo is empty.

Install the device at the correct location to measure level correctly and prevent too much bending and traction. If necessary, attach the probe to the bottom of the tank.

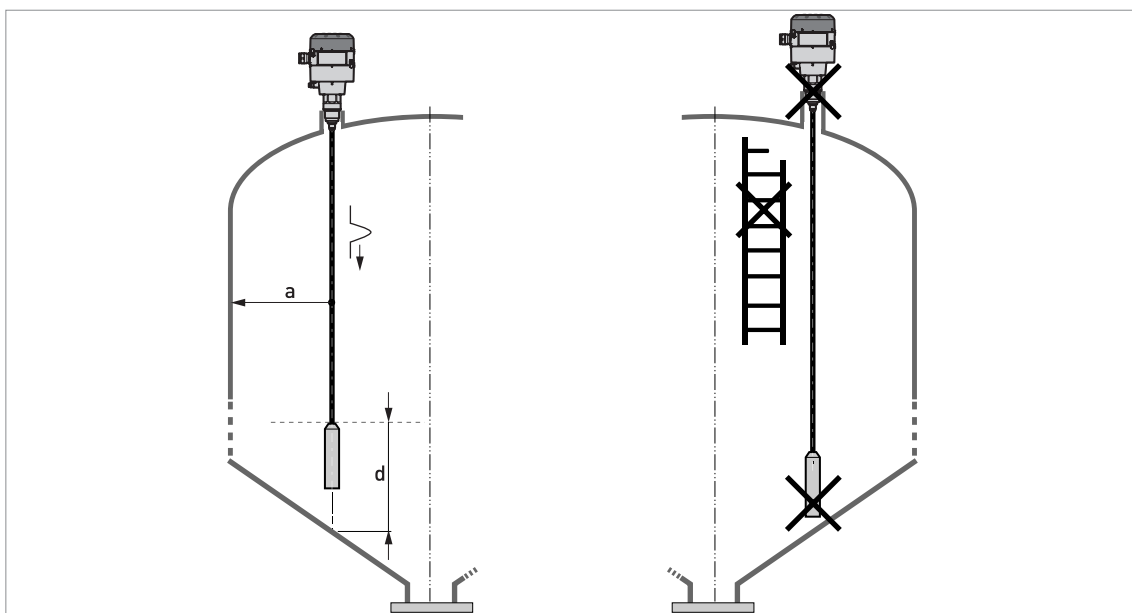

Figure 3-23: Installation recommendations for solids

$a \geq 300 \text{ mm} / 12''$

$d \geq 300 \text{ mm} / 12''$

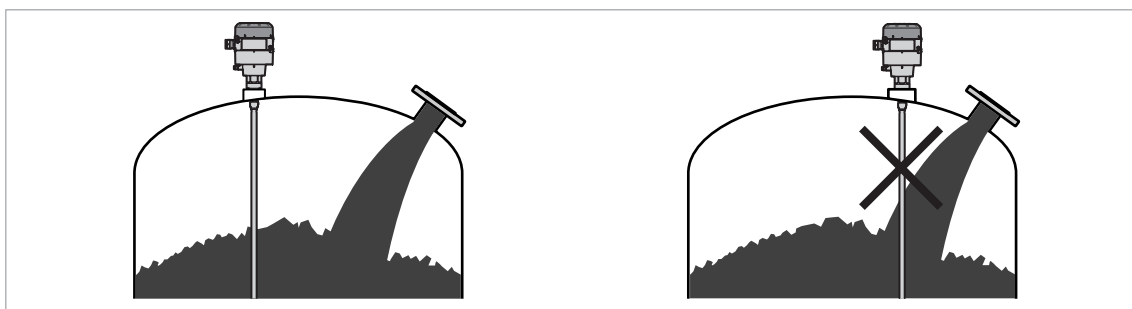

Figure 3-24: Do not install the probe near to a product inlet

3.4 How to install a device with a threaded connection

Equipment needed:

- Gasket (not supplied with G (ISO 228) threaded connections)
- 34 mm wrench (not supplied)

3.5 Recommendations for pits and tanks made of non-conductive materials

If you have a device with a coaxial probe, you can ignore these instructions.

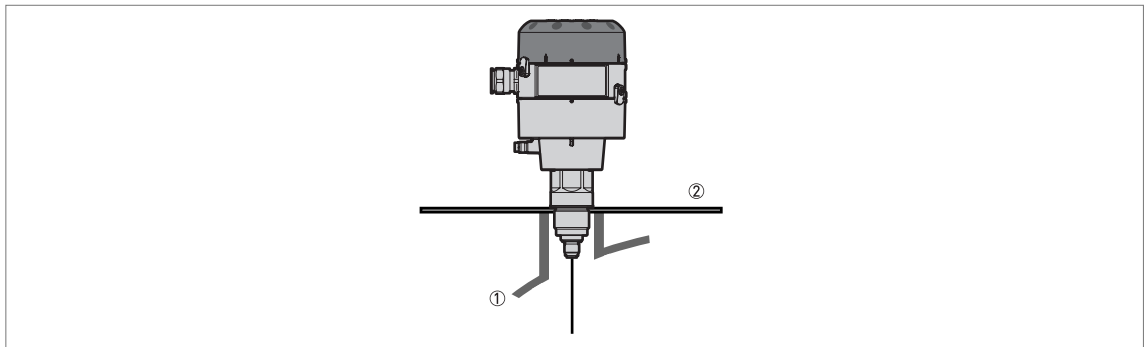

Figure 3-25: Installation in a non-metallic tank or pit with a thread connection

- ① Non-metallic (plastic...) tank or pit
- ② Metal sheet, $\varnothing \geq 200$ mm / 8"

**CAUTION!**

When the device is installed, make sure that the tank roof has no deformation.

3.6 How to turn or remove the signal converter

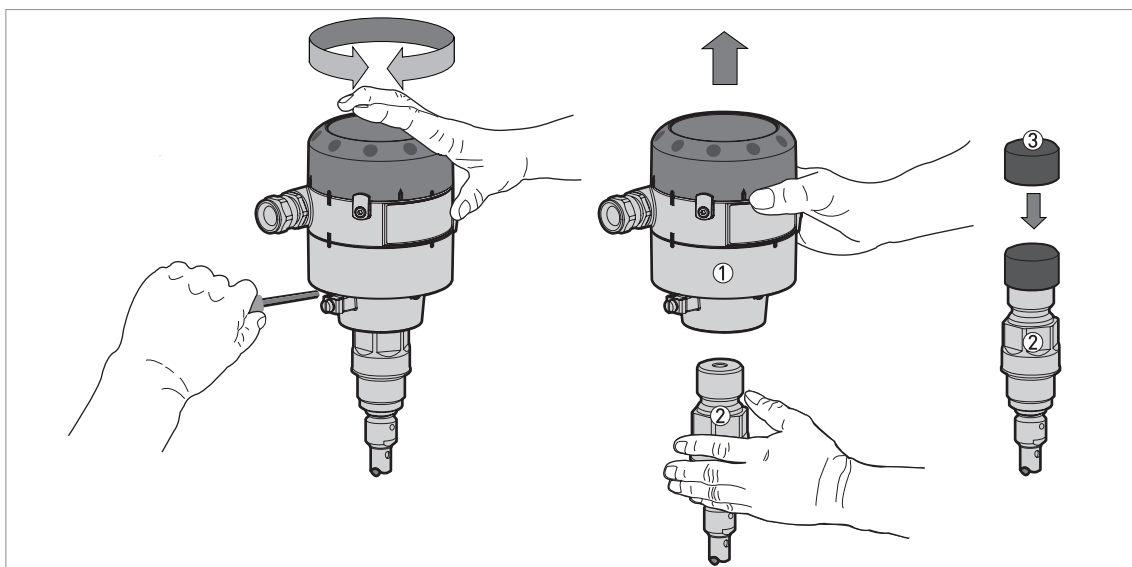

Figure 3-26: How to turn or remove the signal converter

- ① Signal converter
- ② Process connection and probe assembly
- ③ Cover for the coaxial hole on top of the process connection assembly



CAUTION!

When the housing is attached to the process connection assembly, make sure that the lock screw is tight.



How to remove the signal converter

- Loosen the lock screw with a 5 mm wrench.
- Remove the signal converter from the probe assembly.
- Put the cover ③ on the probe assembly.

4.1 Safety instructions



DANGER!

All work on the electrical connections may only be carried out with the power disconnected. Take note of the voltage data on the nameplate!



DANGER!

Observe the national regulations for electrical installations!



WARNING!

Observe without fail the local occupational health and safety regulations. Any work done on the electrical components of the measuring device may only be carried out by properly trained specialists.



INFORMATION!

Look at the device nameplate to ensure that the device is delivered according to your order. Check for the correct supply voltage printed on the nameplate.

4.2 Electrical installation: 2-wire, loop-powered



DANGER!

Solid applications - risk of electrostatic discharge (ESD): Ground the tank, the product and the probe (if attached). The device is resistant to electrostatic discharges of a maximum of 30 kV, but it is the responsibility of the fitter and the user to prevent ESD.

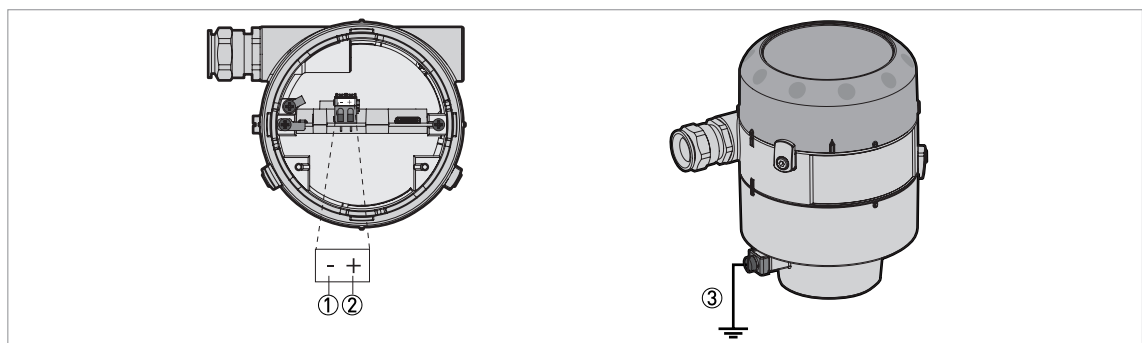

Figure 4-1: Terminals for electrical installation

- ① Current output -
- ② Current output +
- ③ Grounding terminal between the process connection and the converter

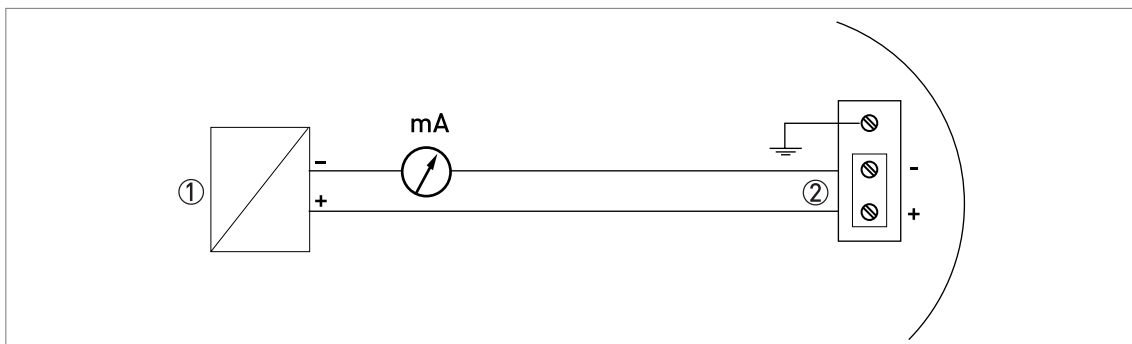

Figure 4-2: Electrical schematic

- ① Power supply
- ② Input: 14...30 VDC



CAUTION!

Make sure that the polarity of the power supply is correct.

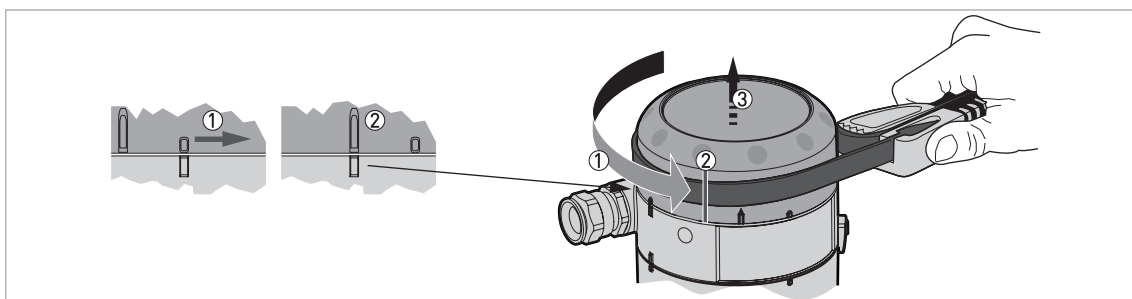

Figure 4-3: How to open the terminal compartment cover



- Turn the cover counterclockwise with a strap wrench.
- Remove the cover.

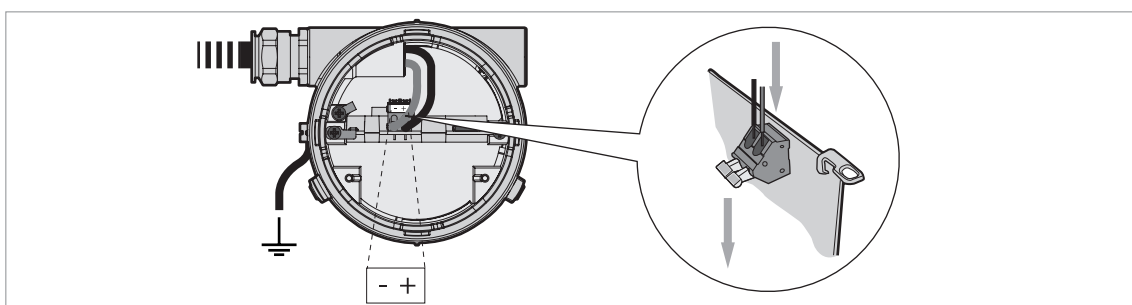

Figure 4-4: How to connect the device to the electrical circuit



WARNING!

If you do not push the wires away from the cover thread when you attach display unit to the signal converter, there is a risk of damage to the wires.

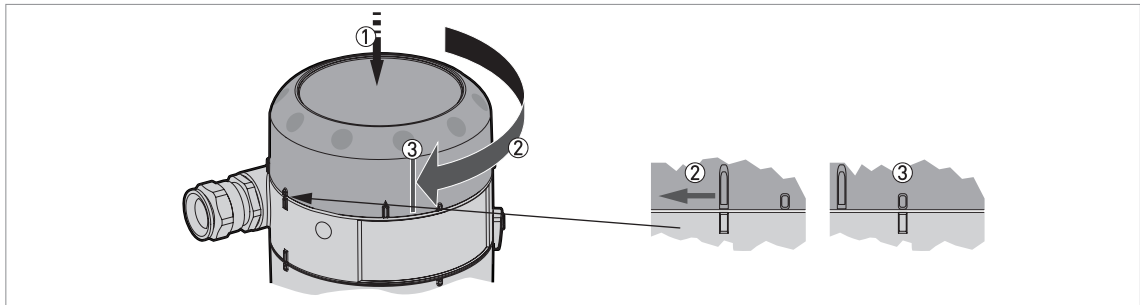

Figure 4-5: How to close the terminal compartment cover



- Attach the cover.
- Turn the cover clockwise.

4.3 Protection category



INFORMATION!

The device fulfills all requirements per protection category IP 66/67 (equivalent to NEMA type 4X (housing) and type 6P (probe)).



DANGER!

Make sure that the cable gland is watertight.

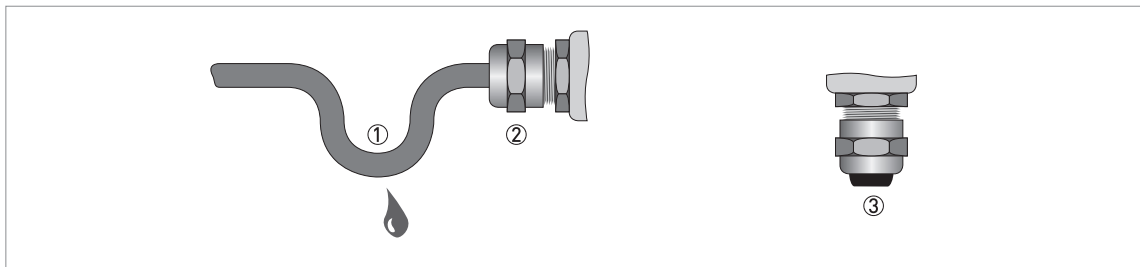

Figure 4-6: How to make the installation agree with protection category IP 67



- Make sure that the gaskets are not damaged.
- Make sure that the electrical cables are not damaged.
- Make sure that the electrical cables agree with the national electrical code.
- The cables are in a loop in front of the device ① so water does not go into the housing.
- Tighten the cable feedthroughs ②.
- Close unused cable feedthroughs with dummy plugs ③.

4.4 How to attach the optional display unit to the device

If the device was supplied with a blind cover, you can attach a display unit or configuration tool to do the quick setup procedure. Use the procedure that follows:

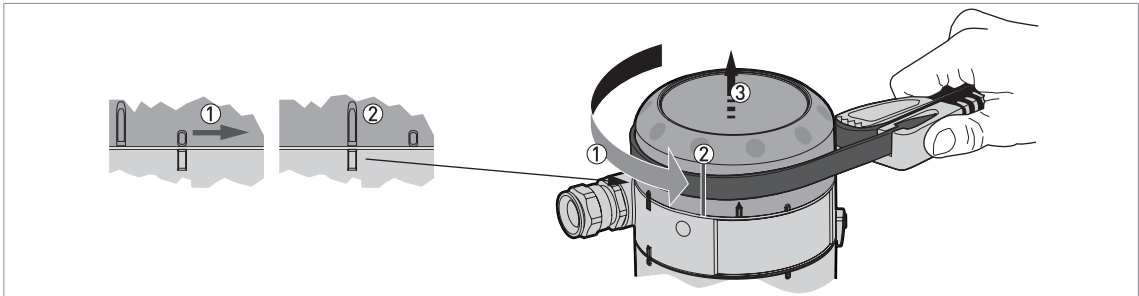

Figure 4-7: How to open the terminal compartment cover



- Turn the cover counterclockwise with a strap wrench.
- Remove the cover.

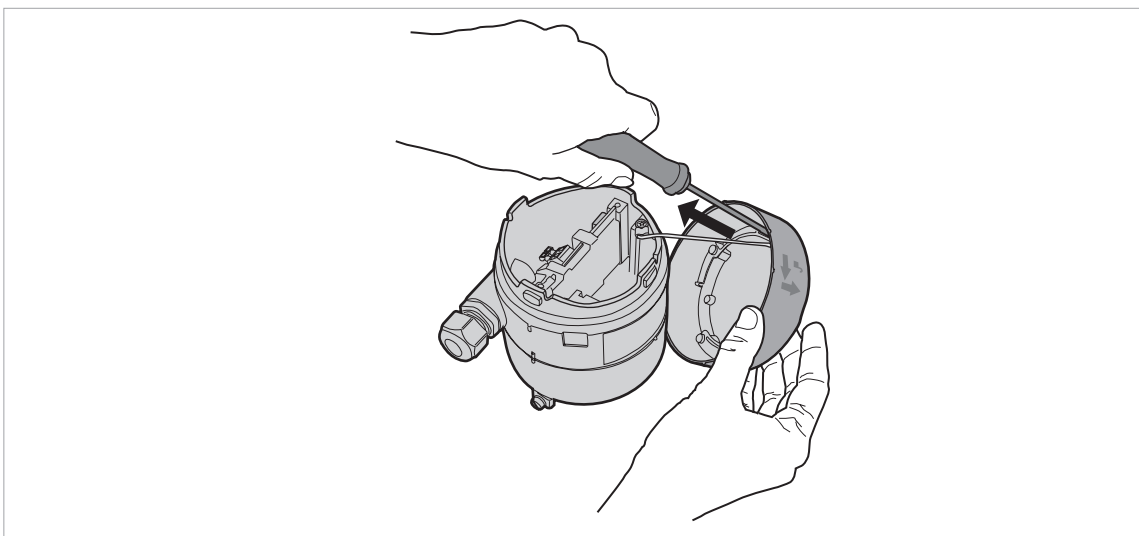

Figure 4-8: Remove the safety cord from the blind cover



- Remove the screw that attaches the safety cord to the blind cover. Use a TORX T10 wrench.
- Remove the safety cord from the blind cover.

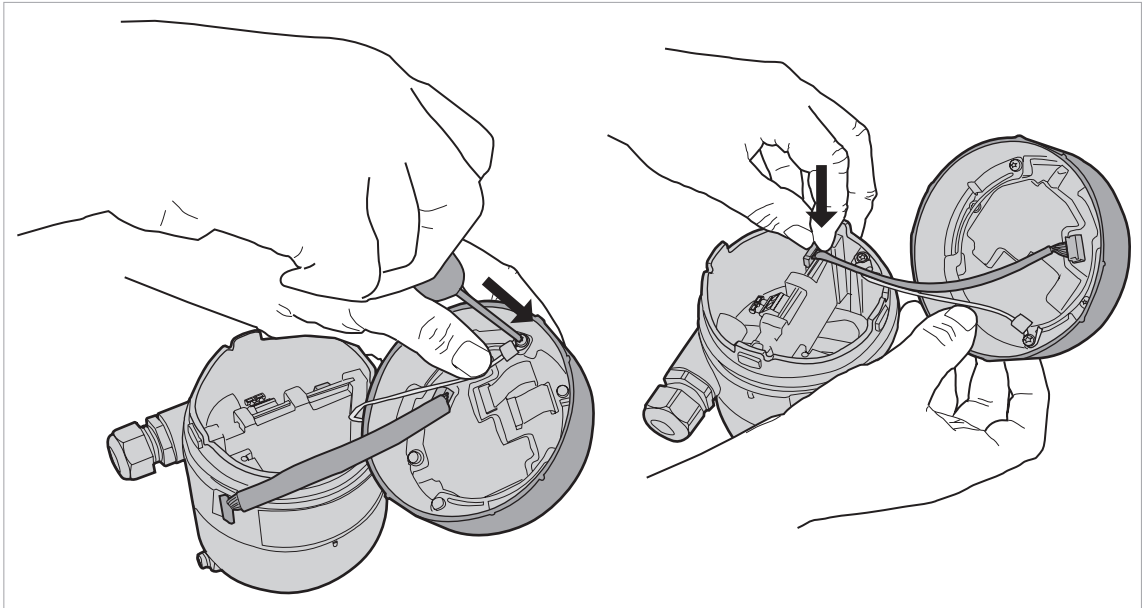

Figure 4-9: Attach the display unit to the electronics block



- Attach the safety cord to the display unit with a TORX T10 wrench.
- Attach the ribbon cable to the electronics block.



WARNING!

If you do not push the wires away from the cover thread when you attach display unit to the signal converter, there is a risk of damage to the wires.

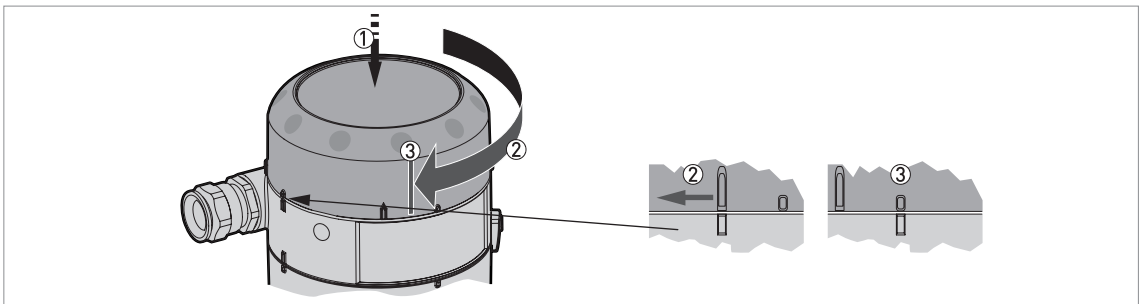

Figure 4-10: How to close the terminal compartment cover



- Attach the cover.
- Turn the cover clockwise.

HMI (Human-Machine Interface) service tool

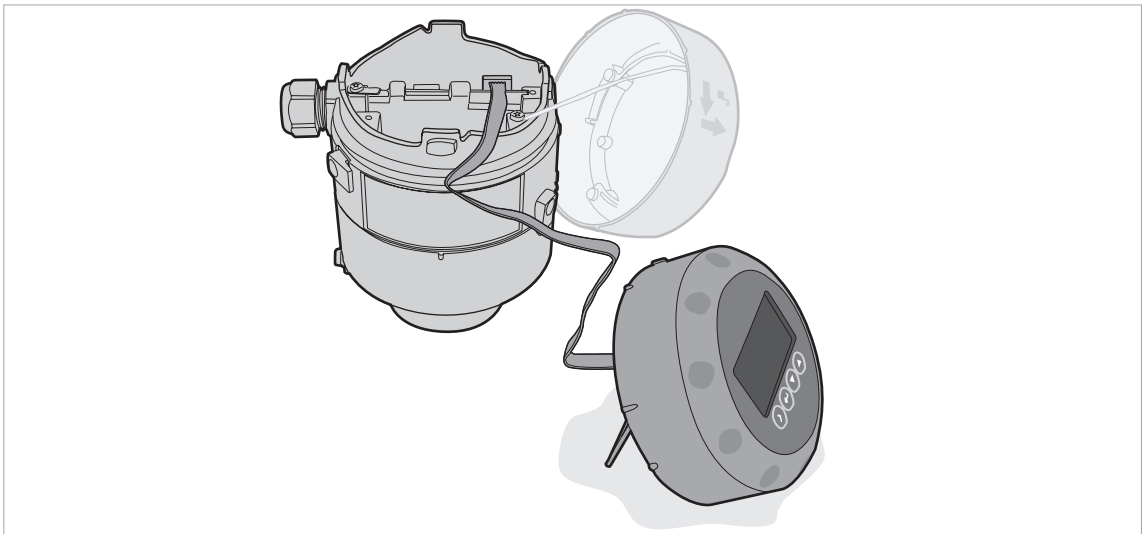

Figure 4-11: Attach the HMI service tool to the electronics block



- Remove the blind cover.
- Attach the ribbon cable of the configuration tool to the electronics block.
- If necessary, extend the leg of the HMI service tool.

5.1 How to start the device

5.1.1 Start-up checklist

Check these points before you energize the device:

- Are all the wetted components (probe, process connection and gaskets) resistant to the product in the tank?
- Does the information on the signal converter nameplate agree with the operating data?
- Did you correctly install the device on the tank?
- Do the electrical connections agree with the national electrical codes?

5.1.2 How to start the device



- Connect the converter to the power supply.
- Energize the converter.
- ➔ **Devices with the LCD display option only:** After 10 seconds the screen will display "Starting up". After 20 seconds the screen will display the software version numbers. After 30 seconds the default screen will appear.
- The device will display readings.
- ➔ Measurements agree with specifications given in the customer order.



CAUTION!

If the manufacturer received data about the installation, the device will display readings correctly. If not, go to sub-menu 1.0.0 QUICK SETUP in the configuration menu to select the correct settings.

5.2 Digital display screen (option)

Display screen

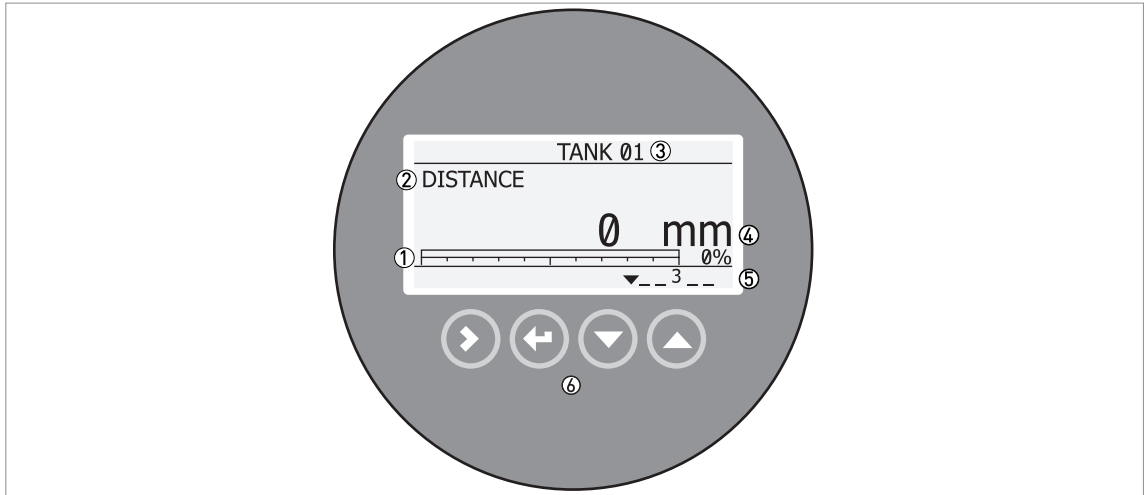

Figure 5-1: Default screen

- ① Current output percentage (bar graph and text - only shown if the output function is the same as the measurement name on the screen in normal mode)
- ② Measurement name (in this example, distance)
- ③ Device tag name
- ④ Measurement value and units
- ⑤ Device status (markers)
- ⑥ Keypad buttons

Keypad functions

| Button | Function |
|--------|---|
| | Normal mode: Enter configuration mode Configuration mode: Move cursor to the right |
| | Normal mode: Change the measurement units (m, cm, in ft) Configuration mode: Exit |
| | Normal mode: Change the measurement name (distance, level, output (%), output (mA)) Configuration mode: Decrease value or change parameter |
| | Normal mode: Change the measurement name (distance, level, output (%), output (mA)) Configuration mode: Increase value or change parameter |

6.1 User modes

| | |
|---------------------------|---|
| Normal mode | This mode displays measurement data. For more data, refer to <i>Normal mode</i> on page 37. |
| Configuration mode | Use this mode to view parameters, commission the device, create tables for volume or mass measurement, change critical values to measure in difficult process conditions. To get access to supervisor menu, refer to <i>Protection of the device settings</i> on page 47. For more data on menu items, refer to <i>Function description</i> on page 38. |

6.2 Normal mode

This mode shows measurement data. Use the table that follows:

- for the selection of the measurement name (level, distance, percentage, conversion),
- for the selection of the measurement units and
- to get access to the configuration mode (INFORMATION and SUPERVISOR menus)

Some data will only be available if the device has the correct parameters entered in the configuration mode.

6.3 Configuration mode

6.3.1 General notes

Change the settings of your device in **Configuration** mode. Data about the menus is given on page 38. You can:

- Use the **1.0.0 QUICK SETUP** menu to commission the device. For more data about the Quick Setup menu, refer to Table 1. Quick Setup.
- Use the **2.0.0 SUPERVISOR** menu to read settings, device software versions and error records, run diagnostic tests, set up a conversion table for volume or mass measurement, change critical parameters for difficult process conditions, reset the device and change basic parameters (tank height etc.), output settings etc. For more data about the Supervisor menu, refer to Table 2. Supervisor.



INFORMATION!

It is not possible to enter the 3.0.0 SERVICE and 4.0.0 MASTER menus. These menus are for factory calibration and qualified service personnel only.

6.3.2 Menu overview

1.0.0 Quick Setup

2.0.0 Supervisor

| | | |
|--------|------------------|---|
| 2.1.0 | Information | Menus for supervisors. Password locked. For more data about the supervisor menu password, refer to <i>Function description</i> on page 38, menu item 2.7.5. |
| 2.2.0 | Tests | |
| 2.3.0 | Basic Parameters | |
| 2.4.0 | Output I | |
| 2.5.0 | Application | |
| 2.6.0 | Communication | |
| 2.7.0 | Display | |
| 2.8.0 | Conversion Table | |
| 2.9.0 | Config/Reset | |
| 2.10.0 | History | |

3.0.0 Service

| | | |
|---|---|--|
| - | - | Menus for factory calibration and qualified service personnel only. Password locked. |
|---|---|--|

4.0.0 Master

| | | |
|---|---|--|
| - | - | Menus for factory calibration and qualified service personnel only. Password locked. |
|---|---|--|

6.3.3 Function description

1. Quick Setup

| Menu No. | Step | Function | Function description | Selection list | Default |
|----------|------|-----------------|--|---|---------|
| 1.0.0 | | Quick Setup | This menu gives a quick set-up procedure applicable to most applications. The user can give the probe type, probe length, output function, 4 mA setting and 20 mA setting. The tank height is set automatically to the same value as the probe length at the end of the procedure. | | |
| | 1 | Setting summary | | Device settings used at this time. Read only. | |
| | 2 | QUICK SETUP? | This tells the device whether or not to continue to the Quick Setup procedure. | Yes [➤], No [▲] | |
| | 3 | PROBE TYPE | Make a selection from the available probe types. | Single cable, Coaxial | |

| Menu No. | Step | Function | Function description | Selection list | Default |
|----------|------|---|---|---|--|
| | 4 | PROBE LENGTH | The probe length includes the length of the counterweight (single cable probes) or the length of the probe end cap (coaxial probes). | min.: 2.3.4 BLOC. DIST. + 3.1.1 COUNTERWEIGHT max.: 20 m / 65.6 ft | ① |
| | 5 | OUTPUT FUNC. | The output function. Select an output function to scale the current values in relation to a given point (usually the device process connection or the tank bottom). The output current value is shown on a bar graph in normal mode if the measurement name is the same as the output function. | Level, Distance | Level |
| | 6 | SCALE 4mA | This gives a measurement value to 4 mA. | min.-max: ② | For level: Single cable= 200 mm / 8"; Coaxial= 0 mm / 0" |
| | 7 | SCALE 20mA | This gives a measurement value to 20 mA. | min.-max: ② | For level: Single cable= Probe length - 450 mm / 18"; Coaxial= Probe length - 250 mm / 10" |
| | 8 | Quick setup completed | An interval of 8 seconds is necessary to use the new settings. | | |
| | 9 | Changes must be saved or cancelled before the device goes back to normal mode | | STORE NO, STORE YES | STORE NO |

① Depends on the probe type. Single cable $\varnothing 2 \text{ mm} / 0.08''$: 20 m / 32.8 ft. Single cable $\varnothing 4 \text{ mm} / 0.15''$: 10 m / 65.6 ft. Coaxial: Depends on the number of probe segments.

② Units and range depend on the output function and length unit selected

2. Supervisor menu

| Menu No. | Function | Function description | Selection list | Default |
|----------|---------------|---|----------------|---------|
| 2.0.0 | SUPERVISOR | The supervisor can use this menu to change parameters. This menu has a password protection. For more data, refer to menu item 2.7.5 PASSWORD in this table. | | |
| 2.1.0 | INFORMATION | A summary of information relating to the device. | | |
| 2.1.1 | SERIAL NUM. | The device serial number. | Read only. | |
| 2.1.2 | CONV.FIRM.VER | The converter firmware version. | Read only. | |

| Menu No. | Function | Function description | Selection list | Default |
|----------|--------------|---|--|--------------|
| 2.1.3 | SEN.FIRM.VER | The sensor firmware version. | Read only. | |
| 2.1.4 | HMI.FIRM.VER | The HMI (device display screen) firmware version. | Read only. | |
| 2.2.0 | TESTS | The device serial number. | | |
| 2.2.1 | SET OUTPUT | This sets the analog output to a test value [mA] selected from a list. The output will change to the selected value after 5 seconds, independent of the measured value. | 3.5, 4, 6, 8, 10, 12, 14, 16, 18, 20 or 22 mA | 3.5 mA |
| 2.2.2 | DIAGNOSTIC | This starts the hardware test. Press [➤] many times to show: the time of operation (D1), temperature of the electronic converter board (T1), loop current (I1), load current (I2), voltage 5.6 V (V1), voltage on capacitors (V2), voltage 3.3 V (V3), amplitude reference pulse (P1), amplitude level pulse (P2), amplitude probe end pulse (P3), reset counter (C1). If you press [➤] again, the display goes back to the menu level. | | |
| 2.3.0 | BASIC PARAM. | The basic parameters for configuration of the device. | | |
| 2.3.1 | TANK HEIGHT | The distance from the thread stop down to the tank bottom. | | Probe length |
| 2.3.2 | TIME CONST. | Increasing the time constant will smoothen the integrated readings, decreasing will roughen the readings. | min-max: 0 to 100 seconds | 5 seconds |
| 2.3.3 | PROBE LENGTH | Probe length is the distance from the thread stop of the device down to the bottom end of the probe (including counterweight for cable versions). If probe length has been modified, enter the new value here. For more data, refer to <i>Quick Setup</i> on page 44. | min: 2.3.4 BLOC. DIST. + 3.1.1 COUNTERWEIGHT max.: 20 m / 65.6 ft | ① |
| 2.3.4 | BLOC. DIST. | Blocking distance. The non-measuring range at the top of the probe. It depends on the probe type and the installation. Make sure that the product does not go above the blocking distance. There is a risk that the product will overflow and/or cover the device. | min: 0 m / 0 ft max: 2.3.3 PROBE LENGTH | 50 mm / 2" |
| 2.3.5 | TAG NAME | The device has a code (tag name) to identify it. | | |
| 2.4.0 | OUTPUT I | Use this sub-menu to give measurement values to the current output. | | |

| Menu No. | Function | Function description | Selection list | Default |
|----------|--------------|---|--|---|
| 2.4.1 | OUTPUT FUNC. | The output function. Select an output function to scale the current values in relation to a given point (usually the device process connection or the tank bottom). The output current value is shown on a bar graph in normal mode if the measurement name is the same as the output function. Conversion parameters are shown if there is volume or mass data in 2.8.1 INPUT TABLE. | Distance, Level, Conversion, Ullage Conversion | Level |
| 2.4.2 | RANGE I | This parameter sets the range of the current output with (3.8...20.5 mA) or without (4...20 mA) over-run values. It also tells the device what to do if an error occurs. For example, the device will change to an error value of 22 mA if you set RANGE I to 4-20/22E . If you set RANGE I to 4-20 and the device senses a measurement error, the value will stop at the last correct measurement. | 4-20, 4-20/22E, 4-20/3.6E, 3.8-20.5/22E, 3.8-20.5/3.6E | 4-20/3.6E |
| 2.4.3 | SCALE 4mA | This gives a measurement value to 4 mA. | min.-max: ② | For level Single cable probes: 200 mm / 8"; Coaxial probe: 0 mm / 0" |
| 2.4.4 | SCALE 20mA | This gives a measurement value to 20 mA. | min.-max: ② | For level Single cable probes: Probe length - 450 mm / 18"; Coaxial probe: Probe length - 250 mm / 10" |
| 2.4.5 | ERROR DELAY | The time after which the current output changes to an error value. The error value shows that there is a measurement error. MN=minutes and S=seconds. | 0 S, 10 S, 20 S, 30 S, 1 MN, 2 MN, 5 MN, 15 MN | 10 S |
| 2.5.0 | APPLICATION | Use this sub-menu to configure the device when there are difficult process conditions. Only approved personnel can change these parameters. | | |
| 2.5.1 | TRACING VEL. | Tracing velocity. This value must agree with the maximum rate of change of the level of the liquid or solid contents in the tank. | min-max: 0.1...1000 m/min | 10.0 m/min |
| 2.5.2 | AUTO Er CALC | Automatic dielectric constant (ϵ_r) calculation. The device automatically calculates the ϵ_r value of the liquid or solid contents in the tank. | YES, NO | NO |

| Menu No. | Function | Function description | Selection list | Default |
|----------|---------------|---|---------------------------|--|
| 2.5.3 | GAS EPS. R | Dielectric constant (ϵ_r) of the gas in the tank. A major parameter for TDR level measurement devices. If the dielectric constant of the gas is very different from the default value (air), set GAS EPS. R to the ϵ_r value of the gas. | min-max: 0.8...115.00 | 1 |
| 2.5.4 | EPS.R CALCUL. | The calculated ϵ_r value for the liquid or solid contents in the tank. The result of the calculation in 2.5.2 AUTO EPSI. R. This menu item will not be available if 2.5.2 AUTO EPSI. R is not used. | Read only. | |
| 2.5.5 | PROD. EPS. R | Dielectric constant (ϵ_r) of the the liquid or solid contents in the tank. If possible, type in the exact value of the product's dielectric constant. If you do not know the exact value, use 2.5.2 AUTO Er CALC. A new product ϵ_r that is too low will mean that level will read higher than its true value. | min-max: 1.0 to 115.00 | Single cable probes: 10; Coaxial probe: 1.6 |
| 2.5.6 | MEAS. AMP. | Measured pulse amplitude. This is the amplitude of the signal (after reflection on the surface of the tank contents) compared with the amplitude of the reference pulse. This value is measured in thousandths (1...1000) of the reference pulse amplitude (value= 1000). Although this data refers to any point along the device measuring range, the value shows the attenuation of the signal amplitude at a distance of 1 m / 3.3 ft from the thread stop. This value helps you to set the measurement threshold in menu item 2.5.7 MEAS. THRESH. | | |
| 2.5.7 | MEAS. THRESH. | Measurement threshold. If it is difficult to identify the level signal (for example: too many parasite signals), you can increase the threshold. This value is measured in thousandths (1...1000). A threshold of 100 is equivalent to 10% of the amplitude of the reference pulse at a distance of 1 m / 3.3 ft from the thread stop. For more data, refer to <i>Thresholds and parasitic signals</i> on page 51. | min-max: 0 to 1000 | Single cable probes: 35; Coaxial probe: 50 |
| 2.5.8 | PROBE END AMP | This menu item is not available. | | |
| 2.5.9 | PROBE END TH. | This menu item is not available. | min-max: 0 to 1000 | 200 |
| 2.6.0 | SERIAL I/O | Menu items for communication in field networks. Do not use this sub-menu. | | |

| Menu No. | Function | Function description | Selection list | Default |
|----------|--------------|--|---|---|
| 2.6.1 | HART ADDRESS | Do not use this menu item. This menu item is for approved personnel only. | | |
| 2.7.0 | DISPLAY | This sub-menu includes all the display parameters and password security parameters for the supervisor menu. | | |
| 2.7.1 | LANGUAGE | Data can be shown in any of the languages stored in the device. | 9 languages are available: ① English, French German and Italian; ② English, French, Spanish and Portuguese; ③ English, Chinese (Mandarin), Japanese and Russian | If the device has the LCD display option, depends on the customer requirement |
| 2.7.2 | LENGTH UNIT | The length unit shown in normal mode. | m, cm, mm, in (inches), ft (feet) | mm |
| 2.7.3 | CONV UNIT | Conversion unit. The length, volume or mass conversion unit for the conversion table and shown in normal mode. | kg, t, Ston, Lton, m, cm, mm, in, ft, m3, L, gal, ImpGal, ft3, bbl | kg |
| 2.7.4 | PSWD YES/NO | If it is necessary to protect your settings in the supervisor menu with a password, set this menu item to YES . | YES, NO | YES |
| 2.7.5 | PASSWORD | This changes the password for the supervisor menu. Press the buttons up to 6 times in any order. This will be the new password. To confirm the change, enter the new password a second time. | | [>], [←], [▼], [▲], [>] and [↵] |
| 2.7.6 | CONTRAST | The contrast control for the display screen. You can select a shade of grey between light grey (level 20) and black (level 54). | min.-max: 20...54 | 36 |
| 2.8.0 | CONV. TABLE | Conversion table. Use these menu items to set up or erase conversion tables to show length, volume or mass measurement values in normal mode. | | |
| 2.8.1 | INPUT TABLE | The device uses the conversion table to convert measurements to volume and mass readings. The readings are shown in normal mode. Give the number of entries on the table. Enter the height and the related volume / mass values. | max. 30 entries (distance / volume or mass) | 0 entries |
| 2.8.2 | DELETE TABLE | This menu item erases the data in the conversion table. | YES, NO | NO |
| 2.9.0 | CONFIG/RESET | Use this sub-menu to save settings, start the device again or go back to the settings before the last save. | | |
| 2.9.1 | SAVE | This menu item is not available. | YES, NO | NO |
| 2.9.2 | RECALL | This menu item is not available. | YES, NO | NO |

| Menu No. | Function | Function description | Selection list | Default |
|----------|--------------|--|----------------|---------|
| 2.9.3 | RESTART | This menu item starts the device again. | YES, NO | NO |
| 2.10.0 | HISTORY | This sub-menu shows device performance data (error log etc.). | | |
| 2.10.1 | ERROR RECORD | A log of device errors. Press [➤] to read the errors. Press [▲] or [▼] to scroll up or down the list. Each error is identified by a code. Press [➤] again to show the number of incidents and the time since the last incident in days, hours, minutes and seconds. For more data on errors, refer to <i>Status and error messages</i> on page 53. | Read only. | |

① Depends on the probe type. Single cable Ø2 mm / 0.08": 20 m / 32.8 ft. Single cable Ø4 mm / 0.15": 10 m / 65.6 ft. Co-axial: Depends on the number of probe segments.

② Units and range depend on the output function and length unit selected

C. Service menu

| Menu No. | Function | Function description | Selection list | Default |
|----------|----------|---|----------------|---------|
| 3.0.0 | SERVICE | Advanced settings. The settings in this menu are protected with a password. Only approved personnel can change the parameters in this menu. For more data, contact your local sales office. | | |

D. Master menu

| Menu No. | Function | Function description | Selection list | Default |
|----------|----------|--|----------------|---------|
| 4.0.0 | MASTER | Factory settings. The settings in this menu are protected with a password. Only approved personnel can change the parameters in this menu. For more data, contact your local sales office. | | |

6.4 Further information on device configuration

6.4.1 Quick Setup

Use this procedure to change the probe length and give the top and bottom measuring limits. « xx » in the illustrations shows that you can change the value or the parameter. Push the keypad buttons in the correct sequence:



Procedure

| Screen | Steps | Description |
|---|--|---|
| <p>VMI_2 LEVEL 5000 mm 0%</p> | <ul style="list-style-type: none"> [>] 3 times. | Default screen. Enter configuration mode. |
| <p>VMI_2 QUICK SETUP ? YES NO</p> | <ul style="list-style-type: none"> [>] YES - to start the quick set-up procedure, or [▲] NO - to go back to the menu. | |
| <p>VMI_2 PROBE TYPE «COAXIAL»</p> | <ul style="list-style-type: none"> [▲] or [▼] for the selection of the probe type (COAXIAL or SINGLE CABLE). [←] to confirm. | |
| <p>VMI_2 PROBE LENGTH «5000»</p> | <ul style="list-style-type: none"> [>] to change the probe length. [>] to change the position of the cursor. [▼] to decrease the value or [▲] to increase the value. [←] to confirm. | Change this value if you have decreased the length of the probe. The probe length for the cable probe options includes the length of the counterweight. |
| <p>VMI_2 OUTPUT FUNC. «Level»</p> | <ul style="list-style-type: none"> [▲] or [▼] for the selection of the measurement name (Distance, Level, Conversion or Ullage Conv.). [←] to confirm. | If "Level" or "Conversion" is set, the 0% limit for the 4...20 mA scale is at the bottom of the tank. If "Distance" or "Ullage Conv." is set, the 0% limit is at the top of the tank. |
| <p>VMI_2 SCALE 4 mA «0000»</p> | <ul style="list-style-type: none"> [>] to change Scale 4 mA. [>] to change the position of the cursor. [▼] to decrease the value or [▲] to increase the value. [←] to confirm. | Use this step to give the 4 mA output setting (0% limit) in the tank. Distance is measured from the thread stop of the process connection. |
| <p>VMI_2 SCALE 20 mA «3350»</p> | <ul style="list-style-type: none"> [>] to change Scale 20 mA. [>] to change the position of the cursor. [▼] to decrease the value or [▲] to increase the value. [←] to confirm. | Use this step to give the 20 mA output setting (100% limit) in the tank. Distance is measured from the thread stop of the process connection. |
| <p>VMI_2 QUICK SETUP COMPLETED IN 6</p> | | After 8 seconds the Quick Setup is completed. |
| <p>VMI_2 1.0.0 STORE NO</p> | <ul style="list-style-type: none"> [←] to confirm. [▲] or [▼] for the selection of the save option (STORE NO or STORE YES). [←] to confirm. | Set to STORE YES to save and use the data. Set to STORE NO to cancel the changes to the device settings. |

6.4.2 Test

Use this procedure to test the loop current. « xx » in the illustrations shows that you can change the value or the parameter. Push the keypad buttons in the correct sequence:

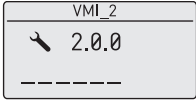
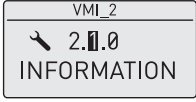
Procedure

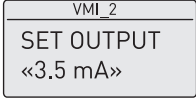
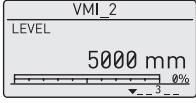
| Screen | Step | Description |
|---|---|---|
|  | | Default screen. |
|  | <ul style="list-style-type: none"> [>], [▲] and [>]. | |
|  | <ul style="list-style-type: none"> Enter the password: [>], [Enter], [▲], [▼] and [>]. [↵] to confirm. | |
|  | <ul style="list-style-type: none"> [▲]. | |
|  | <ul style="list-style-type: none"> [>]. | |
|  | <ul style="list-style-type: none"> [>]. [▼] to decrease the value or [▲] to increase the value. [↵] to confirm. | This step sets the loop current value. Make a selection from 3.5, 4, 6, 8, 10, 12, 14, 16, 18, 20 or 22 mA. |
|  | <ul style="list-style-type: none"> [↵] 3 times to go back to the default screen. | The loop current goes back to initial value. Default screen. |

6.4.3 Protection of the device settings

The menu item PASSWORD (2.7.5) lets you change the supervisor menu password.



How to change the supervisor menu password

- After you enter the supervisor menu, press 6 × [▲], [➤] and 4 × [▲] to go to the menu item PASSWORD (2.7.5).
- Enter the new 6-character password (Press the 4 buttons in any sequence).
- Enter the new 6-character password again.
- ➡ If the second entry is the same as the first, the device will go back to the sub-menu. If the second entry is not the same as the first, the device will not go back to the sub menu. Press ↵ to start the password sequence again and enter the new 6-character password 2 times.
- Press [↵] (Esc) to go back to the "STORE" screen.
- Press ▲ or ▼ to set the screen to **STORE YES** and press [↵].
- ➡ The device will save the new password and go back to normal mode.



INFORMATION!

Make a note of the password and keep it in a safe place. If you lose the password, please contact your supplier.

How to set the supervisor password to "on" or "off"

The supervisor password is set to "on" by default. If it is necessary to set this function to "off", refer to *Function description* on page 38, Table B. Supervisor menu, menu item PSWD YES/NO (2.7.4).

6.4.4 Distance measurement

The device current output agrees with the distance measurement when the output is set to "Distance". Menu items used for distance measurement are:

- Output Function (2.4.1 OUTPUT)
- Tank Height (2.3.1 TANK HEIGHT)
- Blocking Distance (2.3.4 BLOC. DIST.)

Use the thread stop as the reference point for the 4 and 20 mA current output settings. The 4 and 20 mA current output settings are the minimum and maximum points of the measurement scale.

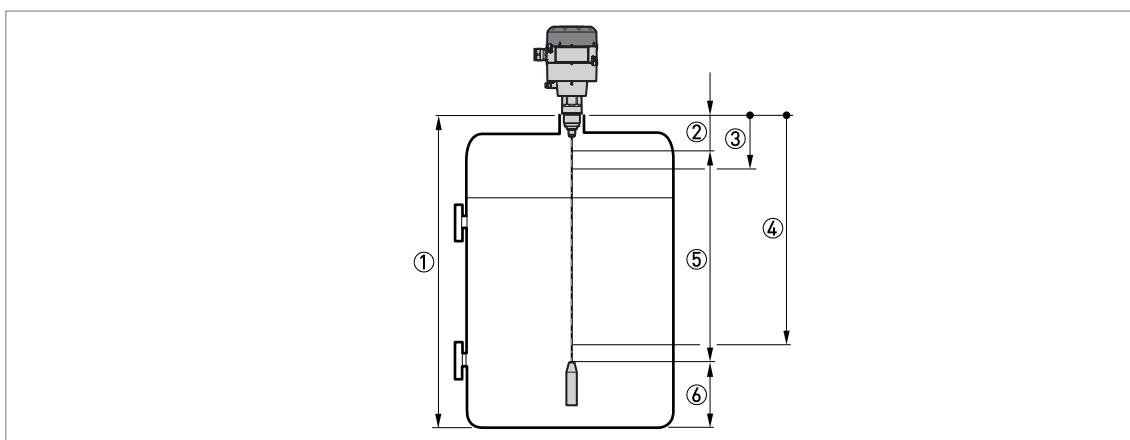

Figure 6-1: Distance measurement

- ① Tank Height (2.3.1 TANK HEIGHT)
- ② Blocking Distance (2.3.4 BLOC. DIST.)
- ③ 4 mA Setting (2.4.3 SCALE 4mA)
- ④ 20 mA Setting (2.4.4 SCALE 20mA)
- ⑤ Maximum effective measuring range
- ⑥ Non-measurement zone

For more data about the menu items, refer to *Function description* on page 38.

6.4.5 Level measurement

The device current output agrees with the level measurement when the output is set to "Level". Menu items related to level measurement are:

- Output Function (2.4.1 OUTPUT)
- Tank Height (2.3.1 TANK HEIGHT)
- Blocking Distance (2.3.4 BLOC. DIST.)

Use the tank bottom as the reference point for the 4 and 20 mA current output settings. The 4 and 20 mA current output settings are the minimum and maximum points of the measurement scale.

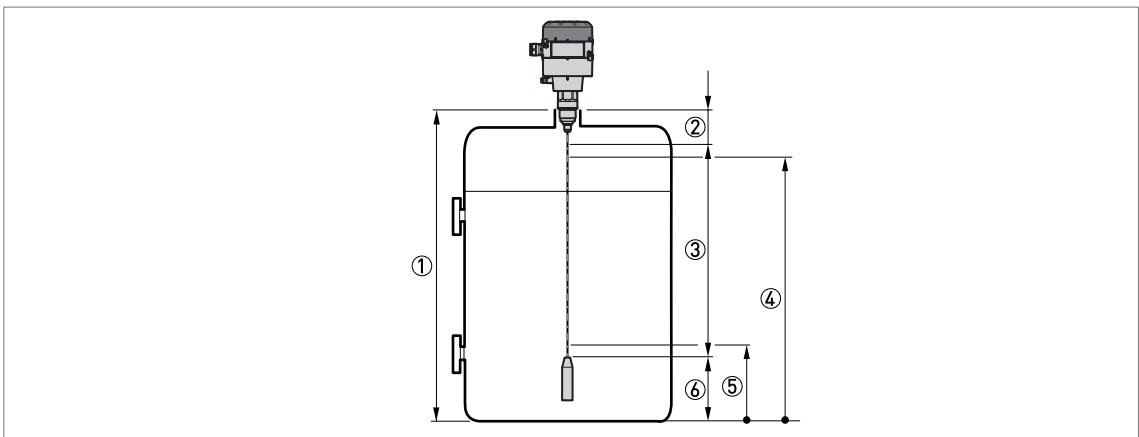

Figure 6-2: Level measurement

- ① Tank Height (2.3.1 TANK HEIGHT)
- ② Blocking Distance (2.3.4 BLOC. DIST.)
- ③ Maximum effective measuring range
- ④ 20 mA Setting (2.4.4 SCALE 20mA)
- ⑤ 4 mA Setting (2.4.3 SCALE 4mA)
- ⑥ Non-measurement zone

For more data about the menu items, refer to *Function description* on page 38.

6.4.6 How to configure the device to measure volume or mass

The device can be configured to measure volume or mass. You can set up a strapping table in the conversion table (2.8.0 CONV. TAB) sub-menu.



How to prepare a strapping table.

- Enter the supervisor menu.
- Press 6 × [▲], [➤] and 2 × [▲] to go to 2.7.2 LENGTH UNIT.
- Press [▲] and [▼] to find the length unit that you will use in the table.
- Press [←] to go to the sub-menu level.
- Press [▲] to go to 2.7.3 CONV UNIT (conversion unit)
- Press [▲] and [▼] to find the conversion unit that you will use in the table.
- Press [←] to go to the sub-menu level and then △ and > to go to the menu item 2.8.1 INPUT TAB
- Press [➤] to make the strapping table. Enter the number of data pairs in the table.
- Enter the length value and press [←].
- Enter the conversion value and press [←].
- Repeat the last 2 steps to complete the table.

The device creates a table of up to 30 pairs of data (level - volume or level - mass). The reference point for the table is the bottom of the tank (as given in menu item 2.3.1 TANK HEIGHT).

The device will give more accurate volume readings if you give more conversion data in these areas:

- Surfaces with curves.
- Sudden changes in the cross section.

Refer also to the illustration that follows:

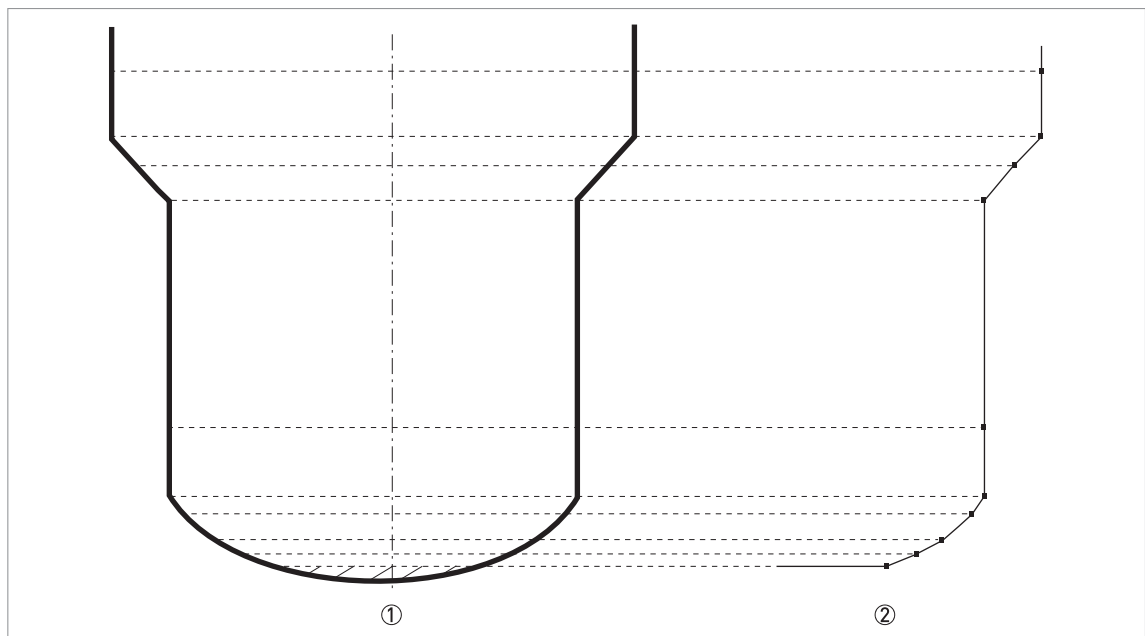

Figure 6-3: A plot of points for a volume or mass table

- ① with reference points
- ② model with plotted points



How to delete a volume or mass table.

- Enter the supervisor menu.
- Press 7 × [▲], [>], and [▲] to go to 2.8.2 DELETE TABLE.
- Press [>] and [▲] to set the parameter to **Sure YES**.
- Press [←] (Esc) to go back to the "STORE" screen.
- Press [▲] or [▼] to set the screen to **STORE YES** and press [←].
- ➔ The device will delete the data for the strapping table and go back to normal mode. The "CONVERSION" and "ULLAGE CONV." data are not available in normal mode.

6.4.7 Thresholds and parasitic signals

General notes

The low-power electromagnetic signal from the device goes down the probe. The surface of the process and objects in the tank make reflections. These reflections go back up the probe to the signal converter. The signal converter changes the reflections into voltage amplitudes. Reflections from objects in the tanks are interference signals (parasitic signals).

How thresholds work

Thresholds let the device ignore reflections with small amplitudes and monitor changes in level.

2.5.7 MEAS. THRESH. (measurement threshold) sets the threshold for the signal after reflection on the surface of the tank contents. This threshold is measured in thousandths (1...1000) of the reference pulse amplitude (value= 1000). A threshold of 100 is equivalent to 10% of the amplitude of the reference pulse at a distance of 1 m / 3.3 ft from the thread stop.

The user can do a check of the signal amplitude after reflection on the surface of the tank contents. 2.5.6 MEAS. AMP. (measured pulse amplitude) is the signal amplitude (after reflection on the surface of the tank contents) compared with the reference pulse amplitude. This value is measured in thousandths (1...1000) of the reference pulse amplitude (value= 1000). Although this data refers to any point along the device measuring range, the value shows the attenuation of the signal amplitude at a distance of 1 m / 3.3 ft from the thread stop. This value helps you to set the measurement threshold in menu item 2.5.7 MEAS. THRESH.



INFORMATION!

For more data on menu items, refer to Function description on page 38.

How to use thresholds



INFORMATION!

If there is a parasitic signal above the level and the threshold is too low, the device can incorrectly use it as the level signal.

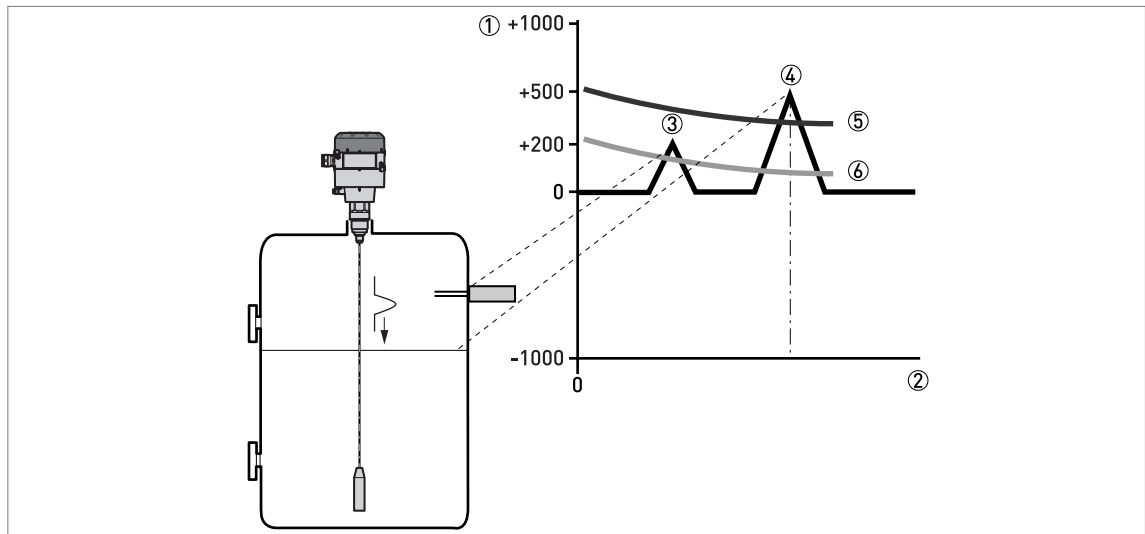

Figure 6-4: Signal intensity/distance graph: thresholds

- ① Signal intensity given as a fraction of the reference pulse (measured in thousandths)
- ② Distance from the process connection
- ③ Parasitic signal. A signal from a level switch that is in the limits of the electromagnetic field around the probe.
- ④ Level signal of the tank contents
- ⑤ The level threshold is correct. The device ignores the parasitic signal and measures level correctly.
- ⑥ The level threshold is too low. The device can use the parasitic signal as the level signal.



If the parasitic signal is smaller than the correct level, you can manually change the threshold to find the signal. This procedure tells you how to change the level threshold to find the correct signal:

- Look at the menu item 2.5.6 MEAS. AMP.
- ➡ Make a note of the amplitude of the correct level signal.
- Go to 2.5.7 MEAS. THRESH.
- Increase the amplitude of the level threshold.
- ➡ This value must be more than the incorrect signal. We recommend that you set the level threshold at half the amplitude of the correct signal.
- Save the settings.
- ➡ The threshold increases. It ignores the parasite signal and uses the first signal it finds.

6.5 Status and error messages

6.5.1 Status markers

If the device senses a change in device status, the display screen will show 1 or more status markers.

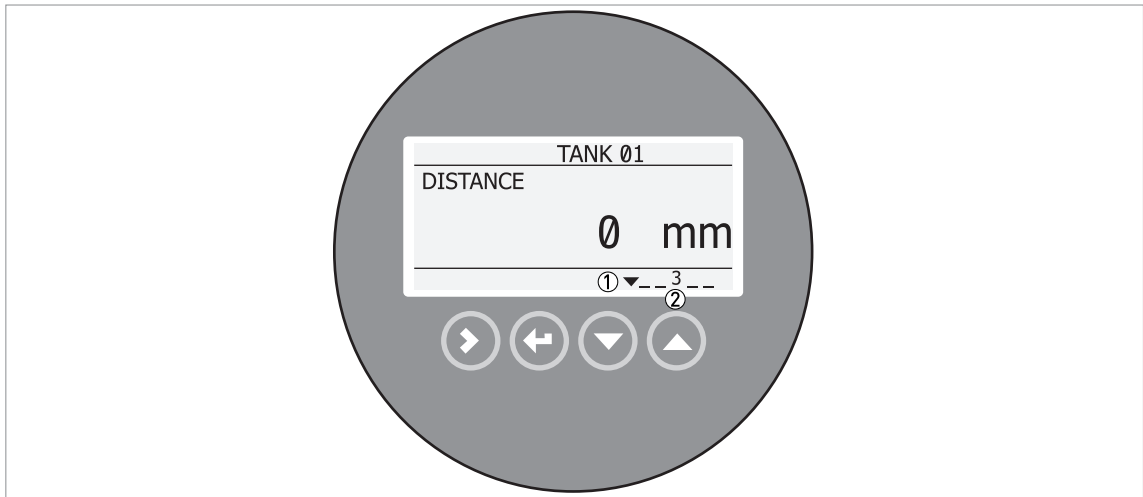

Figure 6-5: Status markers

- ① Status marker line
- ② When the status marker is on, a number is shown

Status markers

| Code | Name | Description |
|------|----------------------------------|---|
| 1 | Hardware problem | The device's hardware is defective. Contact the supplier. |
| 2 | No reference pulse | Reference amplitude is less than reference threshold. This fault could occur because the device hardware is defective. For more data, refer to <i>Error handling</i> on page 54. |
| 3 | Low voltage / Measurement old | This error occurs if the power supply is not sufficient to operate the device correctly for 1 minute. After 1 minute the error message "Measurement old" is recorded. The output current changes to an error value after a time given in menu item 2.4.5 ERROR DELAY. For more data, refer to <i>Error handling</i> on page 54. |
| | | There is a problem with the connection between the sensor and the device converter. Contact the supplier. |
| 4 | Level lost | The device cannot find the product surface or the end of the probe (when $\varepsilon_r < 1.6$). The measurement stops at the last measured value. |

For data on errors, refer to *Error handling* on page 54.

6.5.2 Error handling

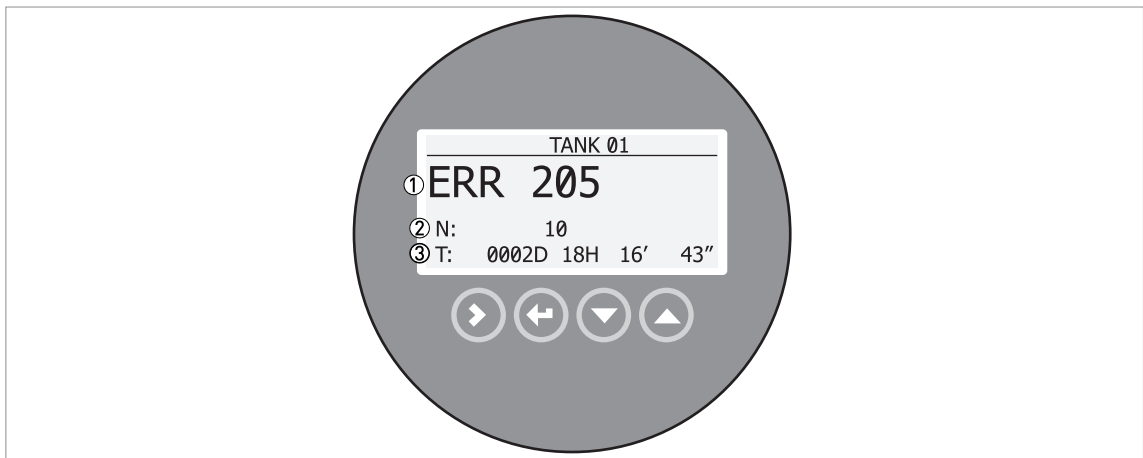

Figure 6-6: Error record data

- ① Error code for the error
- ② Number of times the error occurred
- ③ Time since the last error record



How to find an error record

- Press [>] and [▲] to enter configuration mode from normal mode.
- Press [>], 9 × [▲] and [>] to go to menu item 2.10.0 ERROR RECORD.
- Press 2 × [>] to look at the error list. Press [▲] or [▼] for the selection of an error.
- Press [>] to read more data.
- ➡ The error record gives the number of times the error occurred and the time since the last error message.



INFORMATION!

The time since the error occurred is measured in Days (D), Hours (H), Minutes(') and Seconds ("). It only includes the time when the device is energized. The error is saved in the memory of the device when it is de-energized. The counter continues when the device is energized again.

Description of errors and corrective actions

| Problem | Status marker shown | Error code recorded | Error Message | Cause | Corrective action |
|---|---------------------|---------------------|---------------------------|--|---|
| The measurement stops at the last measured value and the current output value is incorrect. The optional display screen switches off automatically. | 3 | ERR 102 | Temperature out of range | The ambient temperature is outside the given range. This can cause loss or corruption of data. | De-energize the device until the ambient temperature is back in the given range [-40...+80°C / -40...+176°F]. |
| The measurement stops at the last measured value and the current output value is incorrect. | 1 | ERR 103 | Converter memory failure | The device's hardware is defective. | Contact the supplier. |
| | 1 | ERR 104 | Converter voltage failure | The device's hardware is defective. | Contact the supplier. |

| Problem | Status marker shown | Error code recorded | Error Message | Cause | Corrective action |
|---|---------------------|---------------------|-------------------------------------|---|---|
| The display reading does not change and the current output value is incorrect. | 2 | ERR 200 | Reference pulse lost | Reference amplitude is less than reference threshold. This fault could occur because the device hardware is defective. | Contact your supplier to check that the electronics are still functioning correctly. |
| | 1 | ERR 201 | Sensor voltage failure | The device's hardware is defective. | Contact the supplier. |
| The display reading does not change and the current output value is incorrect. | 4 | ERR 202 | Level lost error | The device cannot find the product surface. | Measure the level of the contents in the tank using another method of measurement. If the tank is empty (the level is below the end of the probe), then fill the tank until product level is in the measurement range. If the tank is full (the level is in the blocking distance), then remove the contents from the tank until the level is back in the measuring range. If the product was lost and the tank is neither full nor empty, wait for the device to find the level again. |
| | | | | The device cannot find the level return signal | |
| The measurement and the current output value stops at the "full" value. | 4 | ERR 204 | Overfill error | The tank is full. The level signal is lost in the full area. The measurement stops at the blocking distance value. | Danger of overflow! Remove the contents from the tank until it is at a safe level. |
| The measurement stops at the last measured value and the current output value is incorrect. | 3 | ERR 205 | Measurement old | This error occurs if the power supply is not sufficient to operate the device correctly for approximately 30 seconds. After 1 minute the error message "Measurement old" is recorded. | Make sure that the power supply has a min./max. value of 14...30 VDC when current output is at 22 mA. |
| | 3 | ERR 206 | No sensor detected | This error occurs if there is a problem with the power supply. | Contact the supplier. |
| | 1 | | | Defective wiring. | |
| | 1 | ERR 207 | Sensor memory failure | The device's hardware is defective. | Contact the supplier. |
| 1 | ERR 208 | Oscillator failure | The device's hardware is defective. | Contact the supplier. | |

7.1 Spare parts availability

The manufacturer adheres to the basic principle that functionally adequate spare parts for each device or each important accessory part will be kept available for a period of 3 years after delivery of the last production run for the device.

This regulation only applies to spare parts which are subject to wear and tear under normal operating conditions.

7.1.1 Order code for spare parts and accessories

We supply spare parts and accessories for this device. When you order spare parts and accessories, please give the reference numbers that follow:

| | | |
|------|---|---|
| XF25 | 4 | |
| | | Housing material |
| | 1 | Aluminium |
| | | Probe / Material / Length |
| | 0 | Without |
| | 1 | Single cable Ø2 mm / 0.08" + Counterweight Ø14 mm / 0.55" × 100 mm / 4" / 316 / 20 m / 65.6 ft - for liquids only |
| | 2 | Counterweight for single cable Ø2 mm / 0.08" (Ø14 mm / 0.55" × 100 mm / 4") / 316L |
| | 3 | Service kit for single cable Ø2 mm / 0.08" (crimp + 20 m / 65.6 ft cable) |
| | 5 | Single cable Ø4 mm / 0.15" + Counterweight Ø20 mm / 0.79" × 100 mm / 4" / 316 / 10 m / 32.8 ft - for solids only |
| | 6 | Counterweight for single cable Ø4 mm / 0.15" (Ø20 mm / 0.8 × 100 mm) / 4" / 316L |
| | 7 | Service kit for single cable Ø4 mm / 0.15" (screws + 10 m / 32.8 ft cable) |
| | A | Coax Ø14 mm / 0.55" - 1 segment / 316L / 680 mm / 26.8" |
| | B | Service kit for coax (bottom part + screws) |
| | C | Set of fasteners for coax (fixing screws) |
| | D | Service kit for coax (bottom parts + screws) + Single cable Ø2 mm / 0.08" / 316 / 20 m / 65.6 ft - for liquids only |
| | | Process connection |
| | 0 | Without |
| | 2 | G ¾A (ISO 228) |
| | 3 | G 1A (ISO 228) |
| | 5 | ¾ NPT (ASME B1.20.1) |
| | 6 | 1 NPT (ASME B1.20.1) |
| | | Converter |
| | 0 | Without |
| | 1 | Complete housing / without HMI / electronics |
| | 2 | Complete housing / with HMI / electronics |
| | 5 | Top cover without HMI |
| | 6 | Top cover with HMI |
| | 7 | HMI service tool ① |
| | A | Back end electronic module |
| | B | Set of fasteners for housing (lock screws; cover gasket) |

7.4 Returning the device to the manufacturer

7.4.1 General information

This device has been carefully manufactured and tested. If installed and operated in accordance with these operating instructions, it will rarely present any problems.



CAUTION!

Should you nevertheless need to return a device for inspection or repair, please pay strict attention to the following points:

- *Due to statutory regulations on environmental protection and safeguarding the health and safety of our personnel, manufacturer may only handle, test and repair returned devices that have been in contact with products without risk to personnel and environment.*
- *This means that the manufacturer can only service this device if it is accompanied by the following certificate (see next section) confirming that the device is safe to handle.*



CAUTION!

If the device has been operated with toxic, caustic, flammable or water-endangering products, you are kindly requested:

- *to check and ensure, if necessary by rinsing or neutralizing, that all cavities are free from such dangerous substances,*
- *to enclose a certificate with the device confirming that is safe to handle and stating the product used.*

7.4.2 Form (for copying) to accompany a returned device

| | | | |
|---|---|------------|--|
| Company: | | Address: | |
| Department: | | Name: | |
| Tel. no.: | | Fax no.: | |
| Manufacturer's order no. or serial no.: | | | |
| The device has been operated with the following medium: | | | |
| This medium is: | water-hazardous | | |
| | toxic | | |
| | caustic | | |
| | flammable | | |
| | We checked that all cavities in the device are free from such substances. | | |
| | We have flushed out and neutralized all cavities in the device. | | |
| We hereby confirm that there is no risk to persons or the environment through any residual media contained in the device when it is returned. | | | |
| Date: | | Signature: | |
| Stamp: | | | |

7.5 Disposal



CAUTION!

Disposal must be carried out in accordance with legislation applicable in your country.

8.1 Measuring principle

This Guided Radar (TDR) level meter has been developed from a proven technology called Time Domain Reflectometry (TDR).

The device transmits low-intensity electromagnetic pulses of approximately one nanosecond width along a rigid or flexible conductor. These pulses move at the speed of light. When the pulses reach the surface of the product to be measured, the pulses are reflected back to the signal converter.

The device measures the time from when the pulse is transmitted to when it is received: half of this time is equivalent to the distance from the reference point of the device to the surface of the product. The time value is converted into an output current of 4...20 mA.

Dust, foam, vapour, agitated surfaces, boiling surfaces, changes in pressure, changes in temperature, changes in dielectric constant and changes in density do not have an effect on device performance.

TDR measurement of level

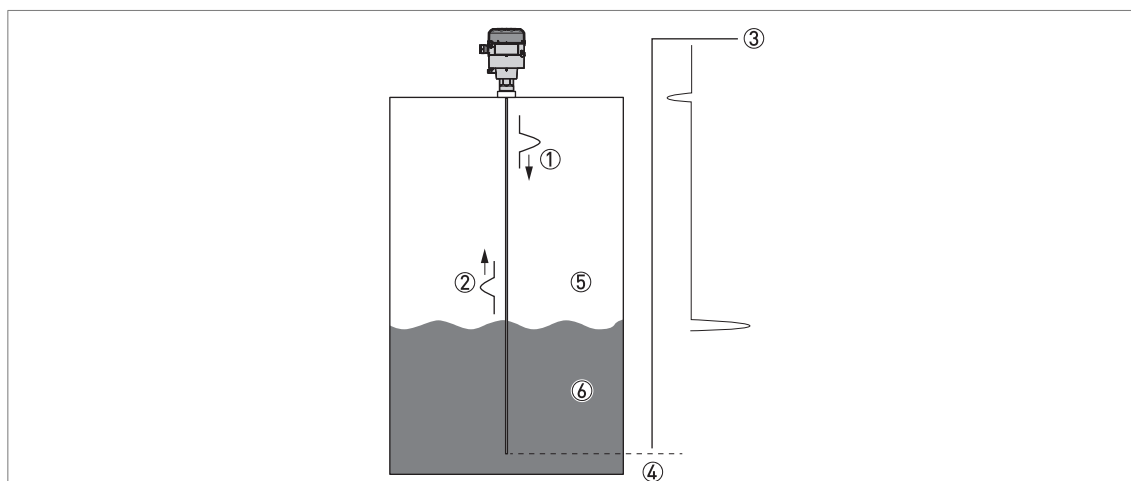

Figure 8-1: TDR measurement of level

- ① Transmitted pulses
- ② Reflected pulse
- ③ Pulse amplitude
- ④ Time of flight
- ⑤ Air, $\epsilon_r = 1$
- ⑥ Liquid, $\epsilon_r \geq 1.6$. Solid, $\epsilon_r \geq 2.1$.

8.2 Technical data



INFORMATION!

- The following data is provided for general applications. If you require data that is more relevant to your specific application, please contact us or your local representative.
- Complete product documentation can be downloaded free of charge from the website (Download Center).

Converter

Measuring system

| | |
|---------------------|---|
| Application | Level and volume measurement of liquids, pastes, powders and granulates |
| Measuring principle | TDR (time domain reflectometry) |
| Construction | Measuring probe attached directly to a signal converter |

Operating conditions

| | |
|---------------------|--|
| Ambient temperature | -40...+80°C / -40...+176°F Integrated LCD display: -20...+60°C / -5...+140°F; if the ambient temperature is not in these limits, the display switches off |
| Storage temperature | -50...+85°C / -60...+185°F |
| Protection category | IP 66/67 |

Materials

| | |
|-------------|---|
| Housing | Polyester-coated aluminium |
| Cable entry | M20 × 1.5 (plastic cable gland included) or ½ NPT (without cable gland) |

Electrical connections

| | |
|---------------------------------|---|
| Power supply (terminals) | 14...30 VDC |
| Current output load | $R_L [\Omega] \leq ((U_{\text{ext}} - 14 \text{ V})/22 \text{ mA})$. For more data, refer to <i>Minimum power supply voltage</i> on page 63. |
| Cable entry capacity (terminal) | 0.5...1.5 mm ² |

Input and output

| | |
|----------------------|---|
| Measured variable | Time between the emitted and received signal |
| Output signal | 4...20 mA or 3.8...20.5 mA |
| Resolution | ±1 µA |
| Error signal options | High: 22 mA; Low: 3.6 mA Hold (frozen value) |

Display and user interface

| | |
|------------------------|--|
| User interface options | LCD display (128 × 64 pixels in 8-step greyscale with 4-button keypad) |
| Languages | 9 languages are available: English, German, French, Italian, Spanish, Portuguese, Japanese, Chinese (Mandarin) and Russian |

Approvals and certification

| | |
|----------------------|---|
| CE | This device fulfils the statutory requirements of the EC directives. The manufacturer certifies successful testing of the product by applying the CE mark. |
| Vibration resistance | EN 60068-2-27, -29, -34 |
| EMC | Electromagnetic Compatibility Directive 2004/108/EC in conjunction with EN 61326-1 (2006). The device agrees with this standard if: - the device has a coaxial probe or - the device has a single probe that is installed in a metallic tank. |

Probe options

| | Segmented coaxial Ø14 mm / 0.55" | Single cable Ø2 mm / 0.08" | Single cable Ø4 mm / 0.15" |
|--|-------------------------------------|-------------------------------|-------------------------------|
|--|-------------------------------------|-------------------------------|-------------------------------|

Measuring system

| | | | |
|-----------------|--|-----------------------------|-----------------------------|
| Application | Level measurement of liquids | | Level measurement of solids |
| Measuring range | 0.73...4.067 m / 2.4...13.3 ft ① | 1...20 m / 3.3...65.6 ft | 1...10 m / 3.3...32.8 ft |
| Dead zone | This depends on the type of probe. For more data, refer to <i>Measurement limits</i> on page 64. | | |

Measuring accuracy

| | | |
|--------------------------------|--|----------------|
| Accuracy | ±10 mm / ±0.4", when distance ≤ 10 m / 33 ft; ±0.1% of measured distance, when distance > 10 m / 33 ft | ±20 mm / ±0.8" |
| Resolution | 1 mm / 0.04" | |
| Repeatability | ±2 mm / ±0.08" | |
| Maximum rate of change at 4 mA | 10 m/min / 32.8 ft/min | |

Operating conditions

| | | | |
|---------------------|---------------------------------|-------------|-------|
| Temperature | -50...+100°C / -60...+212°F | | |
| Pressure | -1...16 barg / -14.5...232 psig | | |
| Viscosity | ≤500 mPa.s | 10000 mPa.s | n/a |
| Dielectric constant | ≥ 1.6 | ≥ 2.1 | ≥ 2.1 |

Materials

| | | | |
|-----------------------|------------------------------------|-----------------------------------|-----------------------------------|
| Probe | Stainless steel (1.4404 / 316L) | Stainless steel (1.4401 / 316) | Stainless steel (1.4401 / 316) |
| Gasket (process seal) | EPDM | | |
| Process connection | Stainless steel (1.4404 / 316L) | | |

Process connections

| | |
|--------|---------------------|
| Thread | G ¾...1A; ¾...1 NPT |
|--------|---------------------|

① The coaxial probe can be supplied in 6 standard lengths: 730 mm / 29", 1397 mm / 55", 2065 mm / 81", 2732 mm / 108", 3400 mm / 134" or 4067 mm / 160". If necessary, shorten the probe. For more data, refer to the Installation chapter.

8.3 Minimum power supply voltage

Use this graph to find the minimum power supply voltage for a given current output load.

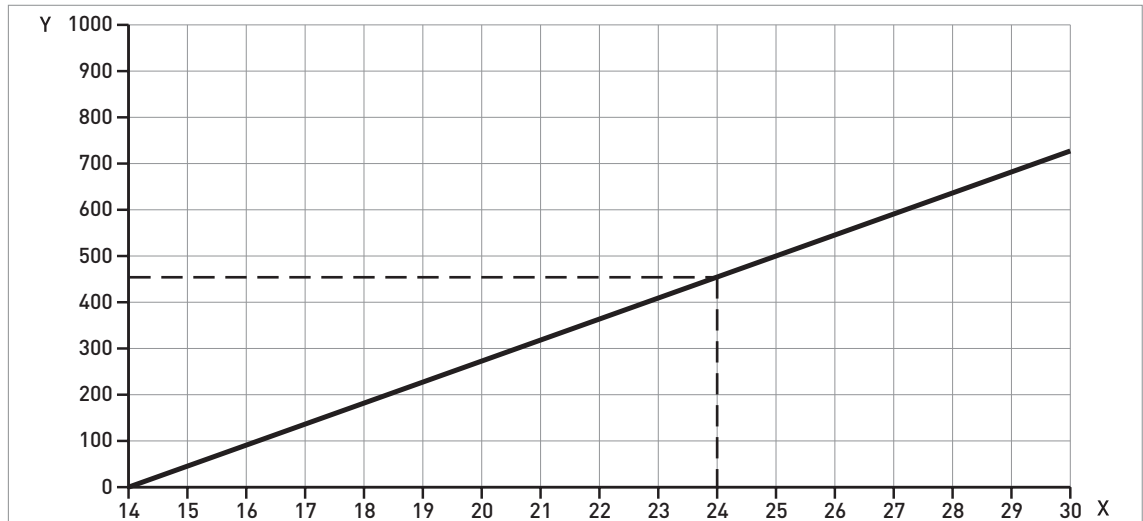

Figure 8-2: Minimum power supply voltage for an output of 22 mA at the terminal

X: Power supply U [VDC]

Y: Current output load R_L [Ω]

8.4 Measurement limits

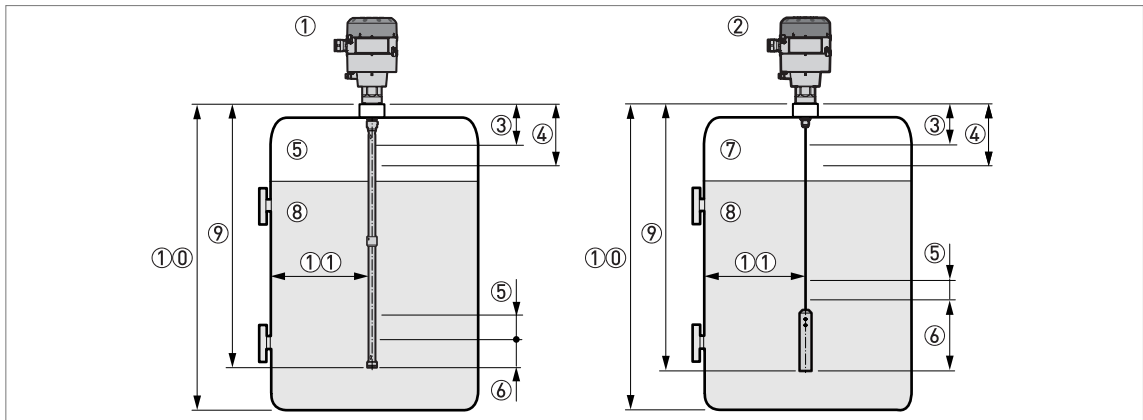

Figure 8-3: Measurement limits

- ① Device with a coaxial probe
- ② Device with a single cable probe
- ③ **Top dead zone:** Top part of the probe where measurement is not possible
- ④ **Top non-linearity zone:** Top part of the probe with a lower accuracy of +40 mm/-10 mm / +1.57"/-0.39"
- ⑤ **Bottom non-linearity zone:** Bottom part of the probe with a lower accuracy of ±30 mm / ±1.18"
- ⑥ **Bottom dead zone:** Bottom part of the probe where measurement is not possible
- ⑦ Gas (Air)
- ⑧ Product
- ⑨ L, Probe length
- ⑩ Tank Height
- ⑪ **Minimum distance from the probe to a metallic tank wall:** Coaxial probe = 0 mm / 0". Single cable probes = 300 mm / 12".

Measurement limits (dead zone) in mm and inches

| Dead zone | $\epsilon_r = 80$ | | | | $\epsilon_r = 2.3$ | | | |
|---------------------|-------------------|----------|----------|----------|--------------------|----------|----------|----------|
| | Top ③ | | Bottom ⑥ | | Top ③ | | Bottom ⑥ | |
| | [mm] | [inches] | [mm] | [inches] | [mm] | [inches] | [mm] | [inches] |
| Coaxial probe | 100 | 3.94 | 30 | 1.18 | 150 | 5.91 | 170 | 6.69 |
| Single cable probes | 100 | 3.94 | 110 | 4.33 | 150 | 5.91 | 110 | 4.33 |

Measurement limits (non-linearity zone) in mm and inches

| Non-linearity zone | $\epsilon_r = 80$ | | | | $\epsilon_r = 2.3$ | | | |
|---------------------|-------------------|----------|----------|----------|--------------------|----------|----------|----------|
| | Top ④ | | Bottom ⑤ | | Top ④ | | Bottom ⑤ | |
| | [mm] | [inches] | [mm] | [inches] | [mm] | [inches] | [mm] | [inches] |
| Coaxial probe | 250 | 9.84 | 30 | 1.18 | 250 | 9.84 | 30 | 1.18 |
| Single cable probes | 250 | 9.84 | 80 | 3.15 | 250 | 9.84 | 140 | 5.51 |

80 is ϵ_r of water; 2.3 is ϵ_r of oil

8.5 Dimensions and weights

Converter

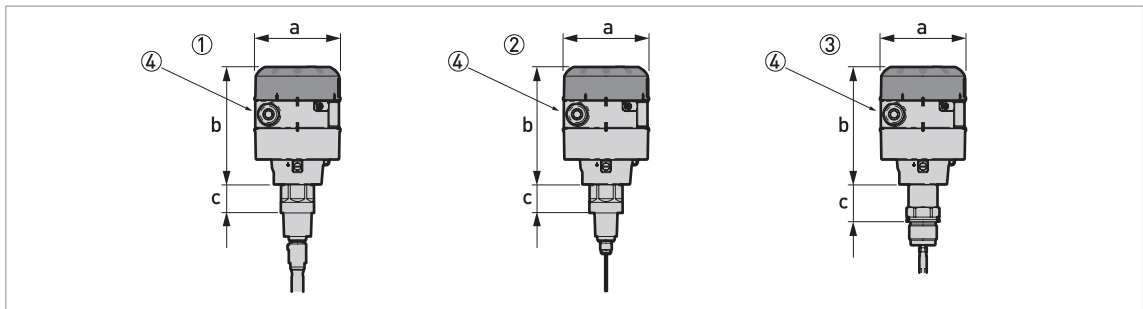

Figure 8-4: Converter dimensions

- ① Converter with a coaxial probe
- ② Converter with a $\varnothing 2$ mm / 0.08" single cable probe
- ③ Converter with a $\varnothing 4$ mm / 0.15" single cable probe
- ④ The diameter of the outer sheath of the cable must be 6...12 mm or 0.23...0.47" (cable entry size M20 \times 1.5)

Dimensions and weights

| | Dimensions | | | | | | Weights | |
|---------|-----------------|----------|------|----------|------|----------|---------|-----|
| | $\varnothing a$ | | b | | c | | | |
| | [mm] | [inches] | [mm] | [inches] | [mm] | [inches] | | |
| ① and ② | 104 | 4.1 | 141 | 5.6 | 34 | 1.3 | 3.3 | 7.3 |
| ③ | 104 | 4.1 | 141 | 5.6 | 45 | 1.8 | 3.3 | 7.3 |

Probes

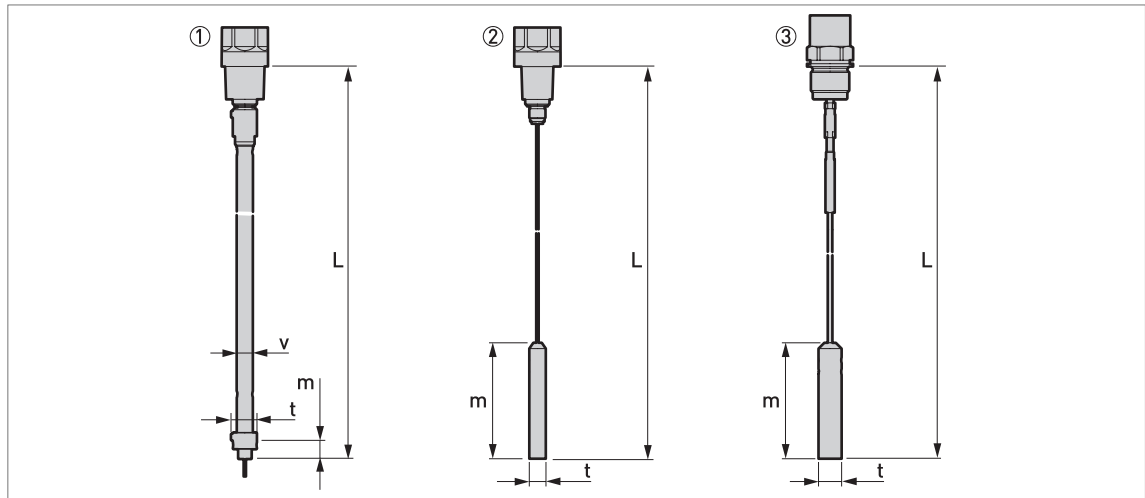

Figure 8-5: Probe dimensions

L is the total length of the probe. This includes the length of the counterweight for cable probes and the probe end cap for coaxial probes.

m is the length of the counterweight or the bottom of the probe end cap for coaxial probes

- ① Ø14 mm / Ø0.55" coaxial probe
- ② Ø2 mm / Ø0.08" single cable probe
- ③ Ø4 mm / Ø0.15" single cable probe



INFORMATION!

For more data, refer to Measurement limits on page 64.

Probes: Dimensions and Weights in mm and kg

| Probes | Dimensions [mm] | | | | | Weights [kg] |
|--------------------|-----------------|--------|-----|-----|-----|--------------|
| | L min. | L max. | m | t | v | |
| Coaxial Ø14 mm | 730 ① | 4067 ② | 15 | Ø21 | Ø14 | 0.45 ③ |
| Single cable Ø2 mm | 1000 ① | 20000 | 100 | Ø14 | - | 0.4 |
| Single cable Ø4 mm | 1000 ① | 10000 | 100 | Ø20 | - | 1.2 |

① All the probes can be shortened on site

② The coaxial probe can be supplied in 6 standard lengths: 730 mm, 1397 mm, 2065 mm, 2732 mm, 3400 mm or 4067 mm

③ This is the weight for each segment of the coaxial probe

Probes: Dimensions in inches and lb

| Probes | Dimensions [inches] | | | | | Weights [lb] |
|---------------------|---------------------|--------|-----|------|-------|--------------|
| | L min. | L max. | m | t | v | |
| Coaxial Ø0.55" | 29 ① | 160 ② | 0.6 | Ø0.8 | Ø0.55 | 0.30 ③ |
| Single cable Ø0.08" | 40 ① | 787 | 4.0 | Ø0.5 | - | 0.88 |
| Single cable Ø0.15" | 40 ① | 394 | 4.0 | Ø0.8 | - | 2.64 |

① All the probes can be shortened on site

② The coaxial probe can be supplied in 6 standard lengths: 29", 55", 81", 108", 134" or 160"

③ This is the weight for each segment of the coaxial probe

9.1 Order code

The characters of the order code highlighted in light grey describe the standard.

| | | | | | |
|------|---|---|--|--|--|
| VF25 | 4 | OPTIFLEX 1100 C 2-wire loop-powered 4...20 mA Guided Radar (TDR) level meter: -50...+100°C and -1...16 barg / -58...212°F and -14.5...232 psig | | | |
| | | Housing material | | | |
| | 1 | Aluminium | | | |
| | | Probe type / probe length (probe material) | | | |
| | 3 | Single cable Ø2 mm / 0.08"; length 20 m / 65.6 ft (St. steel 316/1.4401) | | | |
| | 6 | Single cable Ø4 mm / 0.15"; length 10 m / 32.8 ft (St. steel 316/1.4401) | | | |
| | A | Coaxial; 1 segment; length <730 mm / 29" (St. steel 316L/1.4404) | | | |
| | B | Coaxial; 2 segments; length <1397 mm / 55" (St. steel 316L/1.4404) | | | |
| | C | Coaxial; 3 segments; length <2065 mm / 81" (St. steel 316L/1.4404) | | | |
| | D | Coaxial; 4 segments; length <2732 mm / 108" (St. steel 316L/1.4404) | | | |
| | E | Coaxial; 5 segments; length <3400 mm / 134" (St. steel 316L/1.4404) | | | |
| | F | Coaxial; 6 segments; length <4067 mm / 160" (St. steel 316L/1.4404) | | | |
| | | Process connection | | | |
| | 2 | G ¾A (ISO 228) | | | |
| | 3 | G 1A (ISO 228) | | | |
| | 5 | ¾ NPT (ASME B1.20.1) | | | |
| | 6 | 1 NPT (ASME B1.20.1) | | | |
| | | Cable entry / cable gland | | | |
| | 1 | M20 × 1.5 / plastic | | | |
| | 2 | ½ NPT (Brass) / without | | | |
| | | Display | | | |
| | 1 | Blind version | | | |
| | 2 | With an integrated display | | | |
| | | Display language (English is supplied with all devices) | | | |
| | 0 | Without (for the blind version of the device) | | | |
| | 1 | English | | | |
| | 2 | German | | | |
| | 3 | French | | | |
| | 4 | Italian | | | |
| | 5 | Spanish | | | |
| | 6 | Portuguese | | | |
| | 7 | Japanese | | | |
| | 8 | Chinese (Mandarin) | | | |
| | A | Russian | | | |
| VF25 | 4 | Order code | | | |

9.2 Glossary

C

Cable This is a wire rope. It is used as a measurement pulse guide.

D

Dielectric constant An electrical property of the product to be measured used in TDR measurement. Also known as ϵ_r , DK and relative permittivity. This gives the strength of the measurement pulse reflected back to the device's signal converter.

Discontinuities These are objects or parts of objects (including the tank) that are in the tank, are possibly in the probe's empty space and can potentially influence the electromagnetic field around the probe. This can cause a measurement error.

Distance This is a display option. It is the distance from the thread stop to the level (1 product) or the surface of the top product (2 or more products). Refer to the diagrams at the end of this section.

E

Electromagnetic compatibility Defines how much a device influences or is influenced by other devices that generate electromagnetic fields during operation. Refer to European standard EN 61326-1 and EN 61326-2-3 for further details.

Electromagnetic field This is a physical field that is produced by electrically-charged objects and which may affect the behaviour of other objects near to the field.

Empty space A minimum diameter around a probe that should have no objects in it for the device to work correctly. This depends on the probe type. Refer to **Installation** for more details.

L

Level This is a display option. It is the height from the bottom of the tank (user-defined) to the surface of the top product (Tank height – distance). Refer to the diagrams at the end of this section.

M

Mass This is a display option. It shows the total mass of tank contents. Use a mass table or a volume table to display measurement data with mass units.

Measurement pulse The device transmits a short, low-powered electrical pulse or wave transmitted down a guide to the process. The process (or the probe end if in TBF measurement mode) reflects the pulse back to the device.

Measuring length Length, L' , of from the thread stop to end of the guide. If you ordered a cable probe, this does not include the counterweight. Refer to the diagram at the end of this section.

O

Operators Users who can choose how to display measurements. They cannot configure the device in supervisor mode.

P**Probe**

This is either a metallic cable or rod used to guide the measurement pulse to the process.

Probe length

Ordered length of probe, L, from the thread stop to end of the guide. If you ordered a cable probe, this includes the counterweight. Refer to the diagrams at the end of this section.

S**Supervisors**

Users who can configure the device in supervisor mode. They cannot configure the device in service mode.

T**TDR**

Time domain reflectometry (TDR). The principle used by the device to measure level.

Top dead zone

The distance from the thread stop to the top limit of the measuring range. Also refer to *Measurement limits* on page 64.

Threshold

A number of limits set either manually or automatically by the signal converter to identify the reflected measurement pulses from the level and the probe end.

U**Ullage mass**

This is a display option. It shows empty mass or mass of the product that can be put into the tank. Refer to the diagrams at the end of this section.

Ullage volume

This is a display option. It shows the unfilled volume. Refer to the diagrams at the end of this section.

V**Volume**

Total volume of tank contents. Calculated with a volume table.

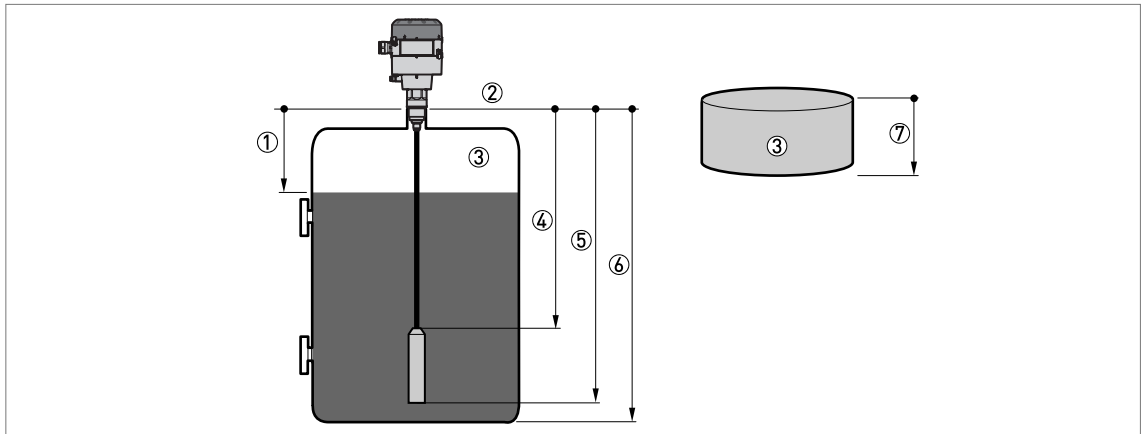

Figure 9-1: Measurement definitions 1

- ① Distance
- ② Thread stop (process connection)
- ③ Gas (Air)
- ④ Measuring length, L'
- ⑤ Probe length, L
- ⑥ Tank height
- ⑦ Ullage volume or mass

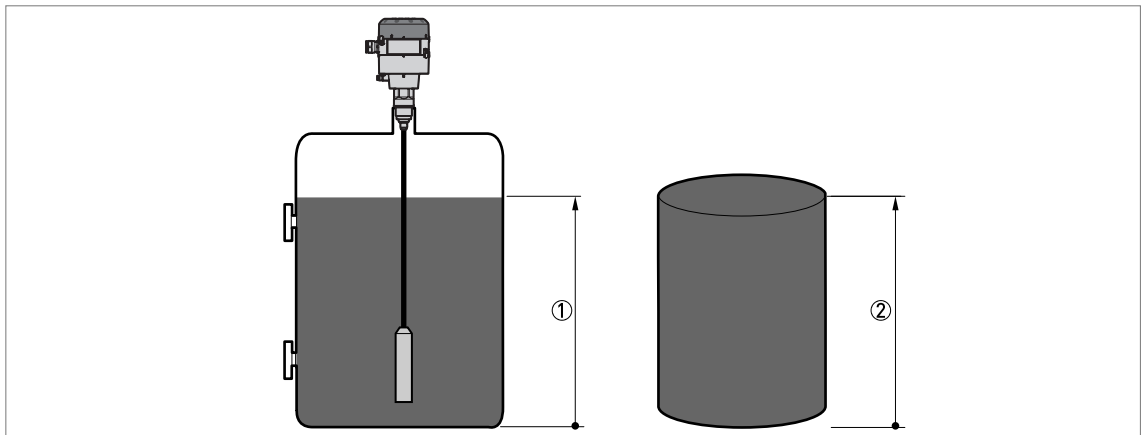

Figure 9-2: Measurement definitions 2

- ① Level
- ② Volume or mass





KROHNE product overview

- Electromagnetic flowmeters
- Variable area flowmeters
- Ultrasonic flowmeters
- Mass flowmeters
- Vortex flowmeters
- Flow controllers
- Level meters
- Temperature meters
- Pressure meters
- Analysis products
- Measuring systems for the oil and gas industry
- Measuring systems for sea-going tankers

Head Office KROHNE Messtechnik GmbH
Ludwig-Krohne-Str. 5
D-47058 Duisburg (Germany)
Tel.: +49 (0)203 301 0
Fax: +49 (0)203 301 10389
info@krohne.de

The current list of all KROHNE contacts and addresses can be found at:
www.krohne.com

KROHNE