



OPTIFLEX 1100 C **Technical Datasheet**

Guided Radar (TDR) Level Meter

- Continuous measurement of liquids and solids
- Cost-effective 2-wire loop-powered TDR level meter
- Intuitive 5-step quick setup procedure

1	Product features	3
1.1	The cost-effective TDR solution	3
1.2	Applications	5
1.3	Application table for probe selection	6
1.4	Measuring principle	7
2	Technical data	8
2.1	Technical data	8
2.2	Minimum power supply voltage	10
2.3	Guidelines for maximum operating pressure	11
2.4	Measurement limits	12
2.5	Dimensions and weights	13
3	Installation	15
3.1	Ø2 mm / 0.08" single cable probe (liquid applications)	15
3.1.1	Intended use	15
3.1.2	Mounting position	15
3.2	Coaxial probe (low-viscosity liquid applications)	15
3.2.1	Intended use	15
3.2.2	Mounting position	16
3.3	Ø4 mm / 0.15" single cable probe (solid applications)	16
3.3.1	Intended use	16
3.3.2	Mounting position	16
4	Electrical connections	18
4.1	Electrical installation: 2-wire, loop-powered	18
5	Order information	19
5.1	Order code	19
6	Notes	21

1.1 The cost-effective TDR solution

OPTIFLEX 1100 C is a 2-wire TDR level meter for measuring distance, level, volume and mass of liquids and solids. Its simple, compact design allows service technicians to quickly assemble the probe and attach it to a threaded connection. It is an affordable solution for applications that do not require a high level of accuracy and is also an excellent alternative to traditional level controls such as RF Capacitance, conductive and DP transmitters.



- ① Aluminium housing with optional LCD display screen
- ② Converter is rotatable and removable under process conditions
- ③ Threaded connection (NPT or G)
- ④ Choice of cable or coaxial probe
- ⑤ 2-wire loop-powered level meter

Optional integrated display

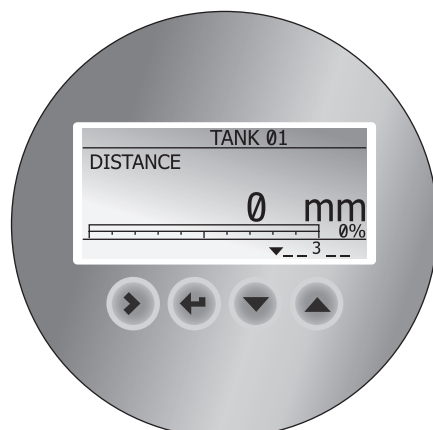

The display can be ordered with the device or as an accessory. It shows measurement data on a 128 × 64 pixel screen. The configuration menu permits the device to be set up in a small number of intuitive steps.

Highlights

- 2-wire loop-powered level meter for liquids and solids
- For general-purpose use (non-hazardous areas)
- Measuring range up to 20 m / 65.6 ft (liquids) and 10 m / 32.8 ft (solids)
- Easy menu navigation without opening the housing
- Probes and process connections are made of stainless steel
- For process temperatures up to 100°C / 210°F and pressures up to 16 barg / 232 psig
- Display in 9 languages: including Chinese, Japanese and Russian

Industries

- **O.E.M. equipment**
e.g. as part of an automatic oil lubrication feed system
- **Machine & skid assembly**
The control of water and cleaning agents in industrial washing machines, filling machines for ink and beverages
- **Tank & silo building**
Tanks for water, oil, underground tanks, rental tanks for glycol etc.
- **Water & wastewater**
Level control in water basins, ports, locks
- **Pulp & paper**
All kinds of storage tanks and recycling tanks
- **Agriculture**
Water control for greenhouses, livestock feed management, blood recovery in abattoirs
- **Chemical**
Storage of plastic pellets
- **Automotive**
Paint booths, lubricant oils
- **Food & beverage**
Various storage and recycling tanks for wine, beer, fruit juice, ...

Applications

- Level measurement in buffer tanks, collectors and simple process applications
- Silo level monitoring in quarrying and agriculture
- Volume measurement for storage tanks (with a 30-point strapping table)

1.2 Applications

1. Level measurement of liquids

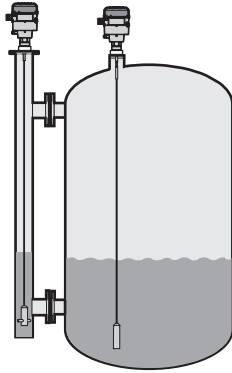

The level meter can measure the level of a wide range of liquid products on a large variety of installations within the stated pressure and temperature range. It does not require any calibration: it is only necessary to adapt the probe length and do a short configuration procedure.

2. Level measurement of solids

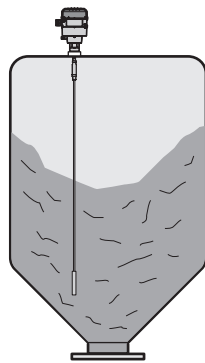

The level meter has a $\varnothing 4$ mm / 0.15" single cable probe for measuring powders and granulates in silos up to 10 m / 32.8 ft high. It does not require any calibration: it is only necessary to adapt the probe length and do a short configuration procedure.

3. Volume measurement

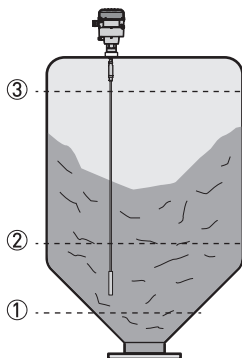

A strapping table function is available in the configuration menu for volume measurement. Up to 30 volume values can be related to level values. For example:

Level ① = 2 m / Volume ① = e.g. 0.7 m³

Level ② = 10 m / Volume ② = e.g. 5 m³

Level ③ = 20 m / Volume ③ = e.g. 17 m³

This data permits the device to calculate volumes between strapping table entries.

1.3 Application table for probe selection

	Segmented coaxial Ø14 mm / 0.55"	Single cable Ø2 mm / 0.08"	Single cable Ø4 mm / 0.15"
--	-------------------------------------	-------------------------------	-------------------------------

Maximum probe length, L

4 m / 13.1 ft			
10 m / 32.8 ft			
20 m / 65.6 ft			

Liquids

Liquid applications, ≤ 10000 mPa.s ($\epsilon_r \geq 2.1$)			
Liquid applications, ≤ 500 mPa.s ($\epsilon_r \geq 1.6$)			
Storage tanks			
Installation in a bypass chamber			
Installation in a stilling well			

Solids

Powders ($\epsilon_r \geq 2.1$)			
Granules, $< \text{Ø}5$ mm / 0.2" ($\epsilon_r \geq 2.1$)			

■ standard ■ optional □ on request

1.4 Measuring principle

This Guided Radar (TDR) level meter has been developed from a proven technology called Time Domain Reflectometry (TDR).

The device transmits low-intensity electromagnetic pulses of approximately one nanosecond width along a rigid or flexible conductor. These pulses move at the speed of light. When the pulses reach the surface of the product to be measured, the pulses are reflected back to the signal converter.

The device measures the time from when the pulse is transmitted to when it is received: half of this time is equivalent to the distance from the reference point of the device to the surface of the product. The time value is converted into an output current of 4...20 mA.

Dust, foam, vapour, agitated surfaces, boiling surfaces, changes in pressure, changes in temperature, changes in dielectric constant and changes in density do not have an effect on device performance.

TDR measurement of level

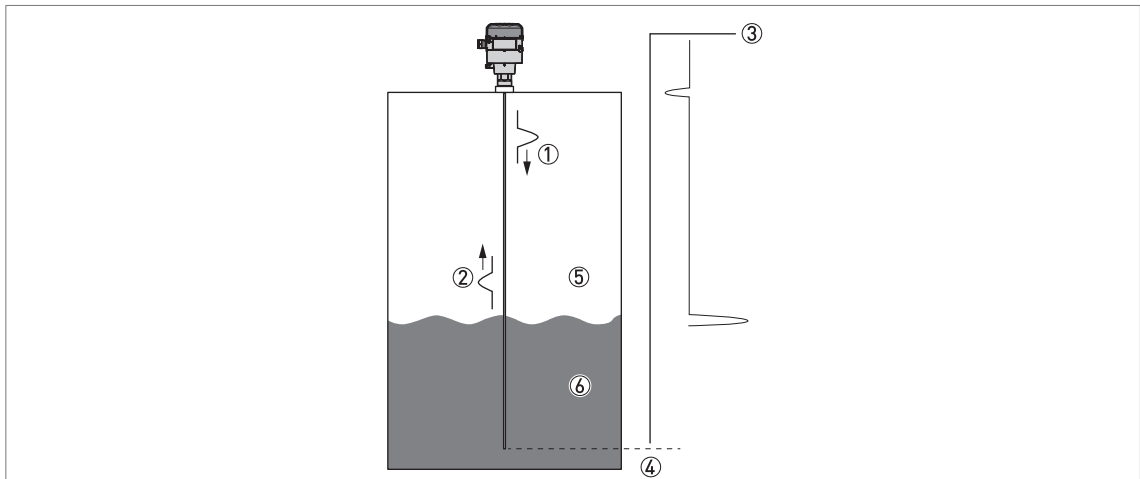

Figure 1-1: TDR measurement of level

- ① Transmitted pulses
- ② Reflected pulse
- ③ Pulse amplitude
- ④ Time of flight
- ⑤ Air, $\epsilon_r = 1$
- ⑥ Liquid, $\epsilon_r \geq 1.6$. Solid, $\epsilon_r \geq 2.1$.

2.1 Technical data

- The following data is provided for general applications. If you require data that is more relevant to your specific application, please contact us or your local representative.
- Complete product documentation can be downloaded free of charge from the website (Download Center).

Converter

Measuring system

Application	Level and volume measurement of liquids, pastes, powders and granulates
Measuring principle	TDR (time domain reflectometry)
Construction	Measuring probe attached directly to a signal converter

Operating conditions

Ambient temperature	-40...+80°C / -40...+176°F Integrated LCD display: -20...+60°C / -5...+140°F; if the ambient temperature is not in these limits, the display switches off
Storage temperature	-50...+85°C / -60...+185°F
Protection category	IP 66/67

Materials

Housing	Polyester-coated aluminium
Cable entry	M20 × 1.5 (plastic cable gland included) or ½ NPT (without cable gland)

Electrical connections

Power supply (terminals)	14...30 VDC
Current output load	$R_L [\Omega] \leq ((U_{ext} - 14 \text{ V}) / 22 \text{ mA})$. For more data, refer to <i>Minimum power supply voltage</i> on page 10.
Cable entry capacity (terminal)	0.5...1.5 mm ²

Input and output

Measured variable	Time between the emitted and received signal
Output signal	4...20 mA or 3.8...20.5 mA
Resolution	±1 µA
Error signal options	High: 22 mA; Low: 3.6 mA Hold (frozen value)

Display and user interface

User interface options	LCD display (128 × 64 pixels in 8-step greyscale with 4-button keypad)
Languages	9 languages are available: English, German, French, Italian, Spanish, Portuguese, Japanese, Chinese (Mandarin) and Russian

Approvals and certification

CE	This device fulfils the statutory requirements of the EC directives. The manufacturer certifies successful testing of the product by applying the CE mark.
Vibration resistance	EN 60068-2-27, -29, -34
EMC	Electromagnetic Compatibility Directive 2004/108/EC in conjunction with EN 61326-1 (2006). The device agrees with this standard if: - the device has a coaxial probe or - the device has a single probe that is installed in a metallic tank.

Probe options

	Segmented coaxial Ø14 mm / 0.55"	Single cable Ø2 mm / 0.08"	Single cable Ø4 mm / 0.15"
--	-------------------------------------	-------------------------------	-------------------------------

Measuring system

Application	Level measurement of liquids		Level measurement of solids
Measuring range	0.73...4.067 m / 2.4...13.3 ft ①	1...20 m / 3.3...65.6 ft	1...10 m / 3.3...32.8 ft
Dead zone	This depends on the type of probe. For more data, refer to <i>Measurement limits</i> on page 12.		

Measuring accuracy

Accuracy	±10 mm / ±0.4", when distance ≤ 10 m / 33 ft; ±0.1% of measured distance, when distance > 10 m / 33 ft	±20 mm / ±0.8"
Resolution	1 mm / 0.04"	
Repeatability	±2 mm / ±0.08"	
Maximum rate of change at 4 mA	10 m/min / 32.8 ft/min	

Operating conditions

Temperature	-50...+100°C / -60...+212°F		
Pressure	-1...16 barg / -14.5...232 psig		
Viscosity	≤500 mPa.s	10000 mPa.s	n/a
Dielectric constant	≥ 1.6	≥ 2.1	≥ 2.1

Materials

Probe	Stainless steel (1.4404 / 316L)	Stainless steel (1.4401 / 316)	Stainless steel (1.4401 / 316)
Gasket (process seal)	EPDM		
Process connection	Stainless steel (1.4404 / 316L)		

Process connections

Thread	G ¾...1A; ¾...1 NPT
--------	---------------------

① The coaxial probe can be supplied in 6 standard lengths: 730 mm / 29", 1397 mm / 55", 2065 mm / 81", 2732 mm / 108", 3400 mm / 134" or 4067 mm / 160". If necessary, shorten the probe. For more data, refer to the handbook.

2.2 Minimum power supply voltage

Use this graph to find the minimum power supply voltage for a given current output load.

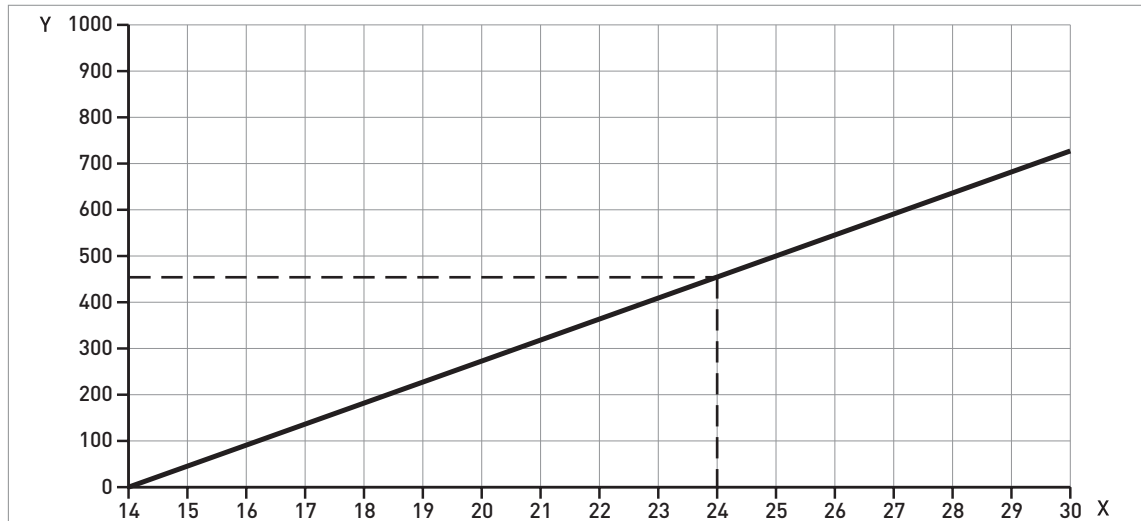

Figure 2-1: Minimum power supply voltage for an output of 22 mA at the terminal

X: Power supply U [VDC]

Y: Current output load R_L [Ω]

2.3 Guidelines for maximum operating pressure

Make sure that the devices are used within their operating limits.

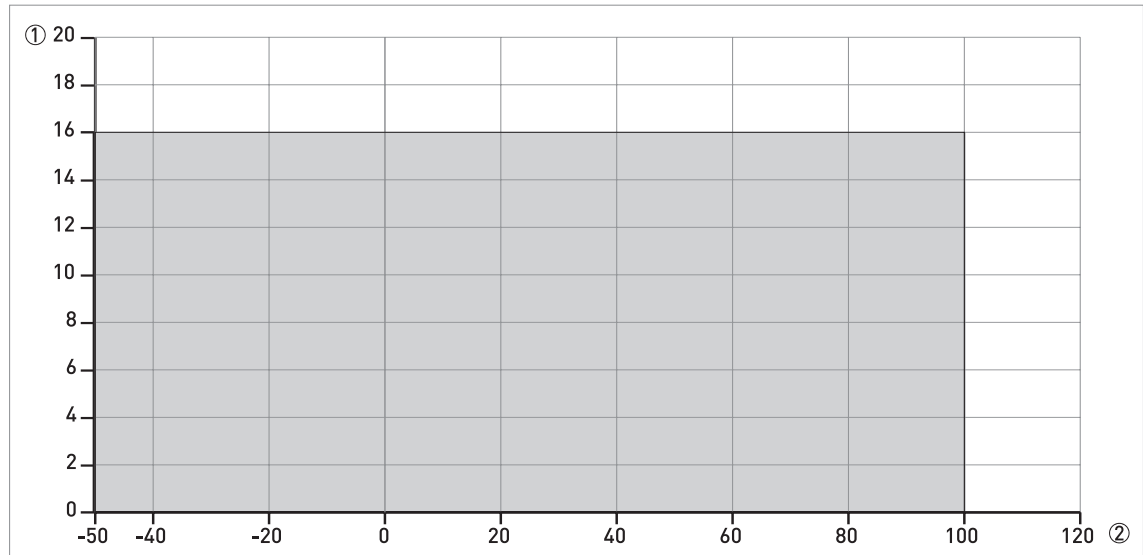

Figure 2-2: Pressure / temperature de-rating, all probe types, in °C and barg

① p [barg]

② T [°C]

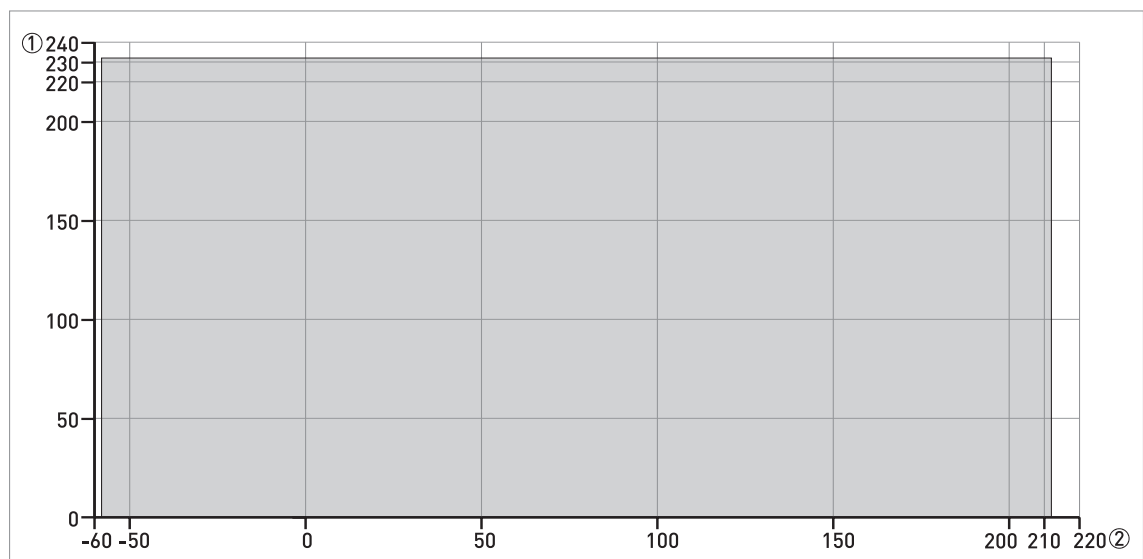

Figure 2-3: Pressure / temperature de-rating, all probe types, in °F and psig

① p [psig]

② T [°F]

2.4 Measurement limits

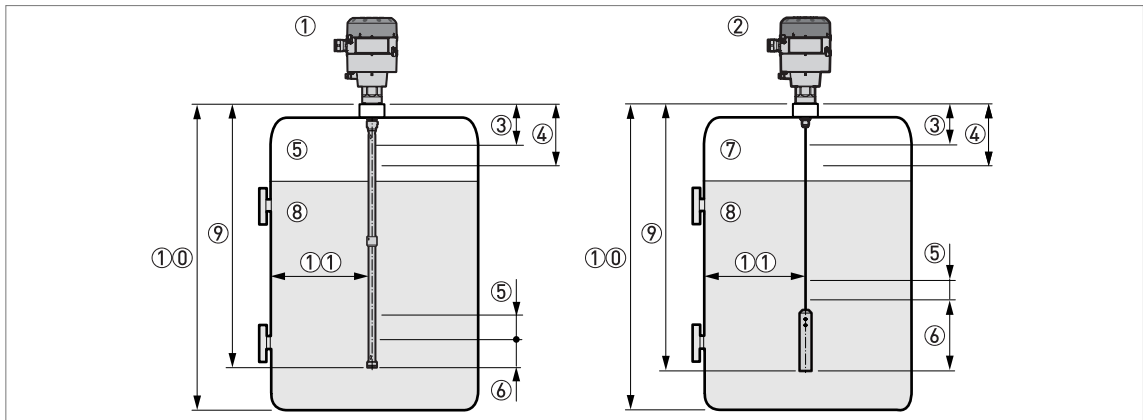

Figure 2-4: Measurement limits

- ① Device with a coaxial probe
- ② Device with a single cable probe
- ③ **Top dead zone:** Top part of the probe where measurement is not possible
- ④ **Top non-linearity zone:** Top part of the probe with a lower accuracy of +40 mm/-10 mm / +1.57"/-0.39"
- ⑤ **Bottom non-linearity zone:** Bottom part of the probe with a lower accuracy of ±30 mm / ±1.18"
- ⑥ **Bottom dead zone:** Bottom part of the probe where measurement is not possible
- ⑦ Gas (Air)
- ⑧ Product
- ⑨ L, Probe length
- ⑩ Tank Height
- ⑪ **Minimum distance from the probe to a metallic tank wall:** Coaxial probe = 0 mm / 0". Single cable probes = 300 mm / 12".

Measurement limits (dead zone) in mm and inches

Dead zone	$\epsilon_r = 80$				$\epsilon_r = 2.3$			
	Top ③		Bottom ⑥		Top ③		Bottom ⑥	
	[mm]	[inches]	[mm]	[inches]	[mm]	[inches]	[mm]	[inches]
Coaxial probe	100	3.94	30	1.18	150	5.91	170	6.69
Single cable probes	100	3.94	110	4.33	150	5.91	110	4.33

Measurement limits (non-linearity zone) in mm and inches

Non-linearity zone	$\epsilon_r = 80$				$\epsilon_r = 2.3$			
	Top ④		Bottom ⑤		Top ④		Bottom ⑤	
	[mm]	[inches]	[mm]	[inches]	[mm]	[inches]	[mm]	[inches]
Coaxial probe	250	9.84	30	1.18	250	9.84	30	1.18
Single cable probes	250	9.84	80	3.15	250	9.84	140	5.51

80 is ϵ_r of water; 2.3 is ϵ_r of oil

2.5 Dimensions and weights

Converter

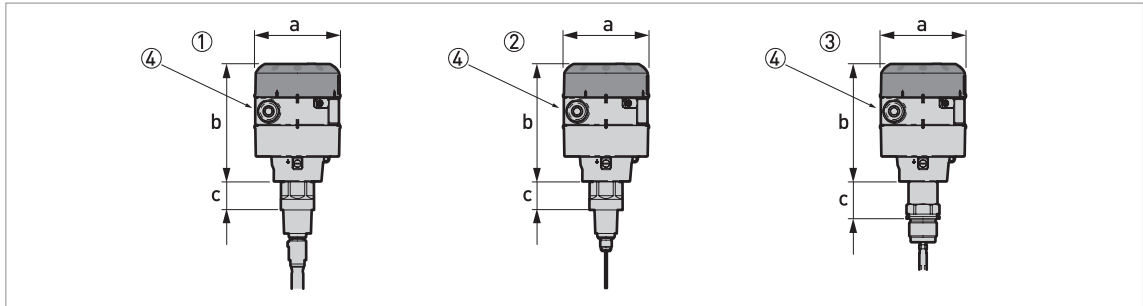

Figure 2-5: Converter dimensions

- ① Converter with a coaxial probe
- ② Converter with a $\varnothing 2$ mm / 0.08" single cable probe
- ③ Converter with a $\varnothing 4$ mm / 0.15" single cable probe
- ④ The diameter of the outer sheath of the cable must be 6...12 mm or 0.23...0.47" (cable entry size M20 \times 1.5)

Dimensions and weights

	Dimensions						Weights	
	$\varnothing a$		b		c			
	[mm]	[inches]	[mm]	[inches]	[mm]	[inches]		
① and ②	104	4.1	141	5.6	34	1.3	3.3	7.3
③	104	4.1	141	5.6	45	1.8	3.3	7.3

Probes

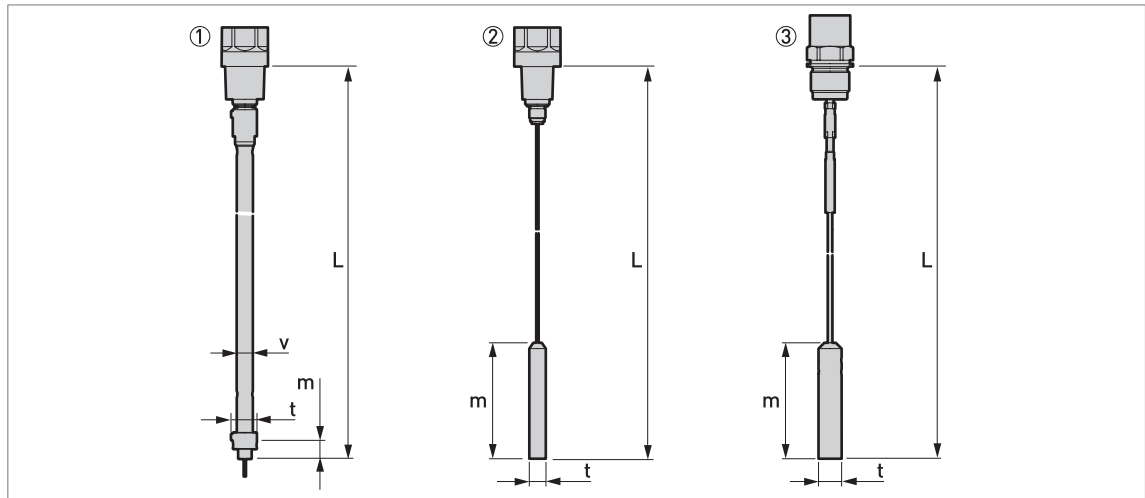

Figure 2-6: Probe dimensions

L is the total length of the probe. This includes the length of the counterweight for cable probes and the probe end cap for coaxial probes.

m is the length of the counterweight or the bottom of the probe end cap for coaxial probes

- ① Ø14 mm / Ø0.55" coaxial probe
- ② Ø2 mm / Ø0.08" single cable probe
- ③ Ø4 mm / Ø0.15" single cable probe

For more data, refer to Measurement limits on page 12.

Probes: Dimensions and Weights in mm and kg

Probes	Dimensions [mm]					Weights [kg]
	L min.	L max.	m	t	v	
Coaxial Ø14 mm	730 ①	4067 ②	15	Ø21	Ø14	0.45 ③
Single cable Ø2 mm	1000 ①	20000	100	Ø14	-	0.4
Single cable Ø4 mm	1000 ①	10000	100	Ø20	-	1.2

① All the probes can be shortened on site

② The coaxial probe can be supplied in 6 standard lengths: 730 mm, 1397 mm, 2065 mm, 2732 mm, 3400 mm or 4067 mm

③ This is the weight for each segment of the coaxial probe

Probes: Dimensions in inches and lb

Probes	Dimensions [inches]					Weights [lb]
	L min.	L max.	m	t	v	
Coaxial Ø0.55"	29 ①	160 ②	0.6	Ø0.8	Ø0.55	0.30 ③
Single cable Ø0.08"	40 ①	787	4.0	Ø0.5	-	0.88
Single cable Ø0.15"	40 ①	394	4.0	Ø0.8	-	2.64

① All the probes can be shortened on site

② The coaxial probe can be supplied in 6 standard lengths: 29", 55", 81", 108", 134" or 160"

③ This is the weight for each segment of the coaxial probe

3.1 Ø2 mm / 0.08" single cable probe (liquid applications)

3.1.1 Intended use

A device with the Ø2 mm / 0.08" single cable probe measures distance and level of liquids, pastes and slurries with a viscosity less than 10000 mPa.s.

3.1.2 Mounting position

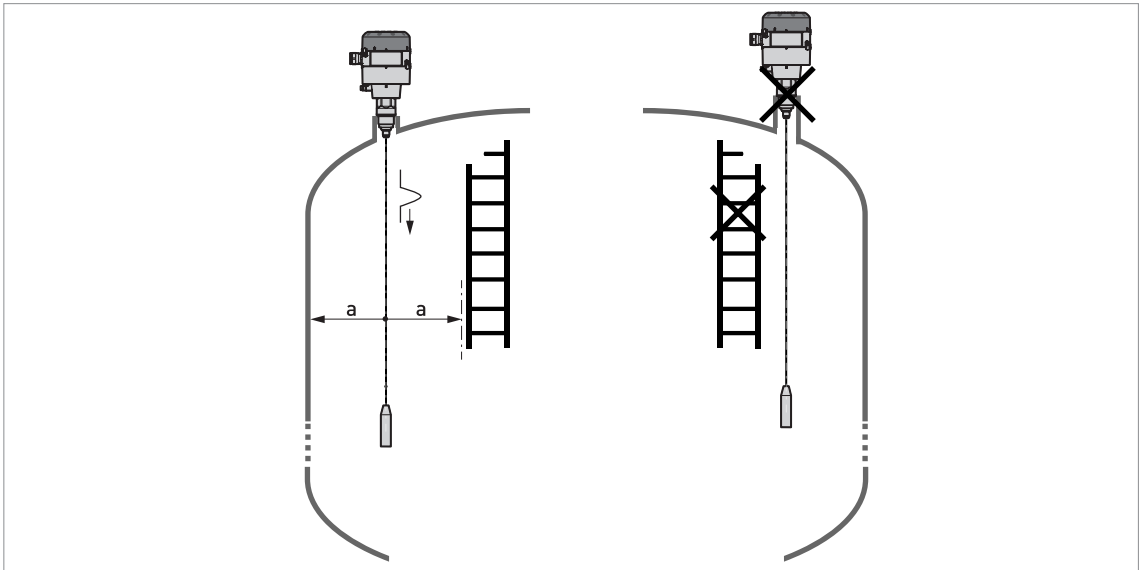

Figure 3-1: Cable probe: minimum distance from metallic walls and other metal objects
 $a \geq 300 \text{ mm} / 12''$

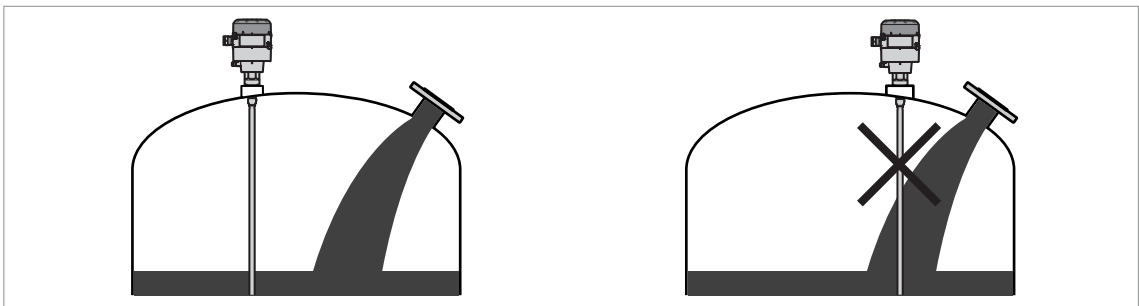

Figure 3-2: Do not install the probe near a product inlet

3.2 Coaxial probe (low-viscosity liquid applications)

3.2.1 Intended use

A device with the coaxial probe measures distance and level of liquids with a viscosity less than 500 mPa.s. It can be installed on tanks and open pits.

3.2.2 Mounting position

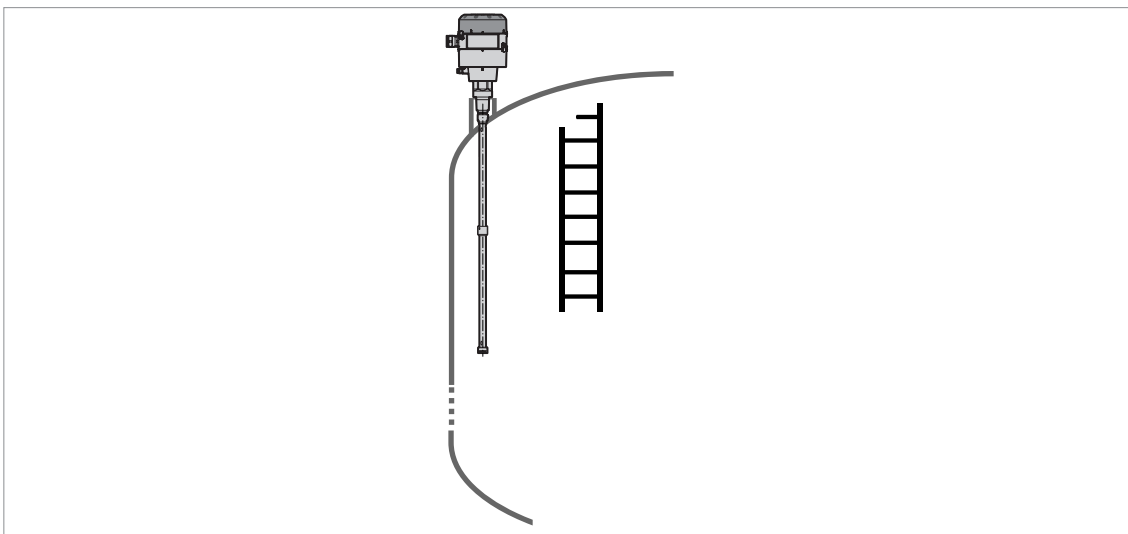

Figure 3-3: Coaxial probe: minimum distance from metallic walls and other metal objects

There is no minimum distance from the coaxial probe to metallic walls and other metal objects.

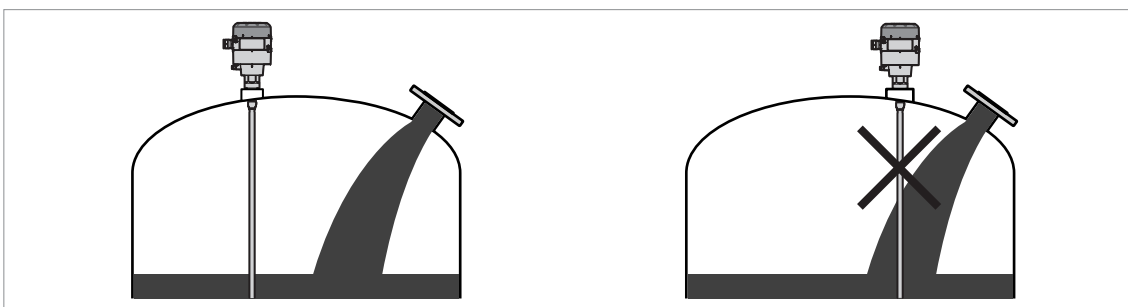

Figure 3-4: Do not install the probe near to a product inlet

3.3 Ø4 mm / 0.15" single cable probe (solid applications)

3.3.1 Intended use

A device with the Ø4 mm / 0.15" single cable probe measures distance and level of granulates and powders.

3.3.2 Mounting position

We recommend that you install the probe when the silo is empty.

Install the device at the correct location to measure level correctly and prevent too much bending and traction. If necessary, attach the probe to the bottom of the tank.

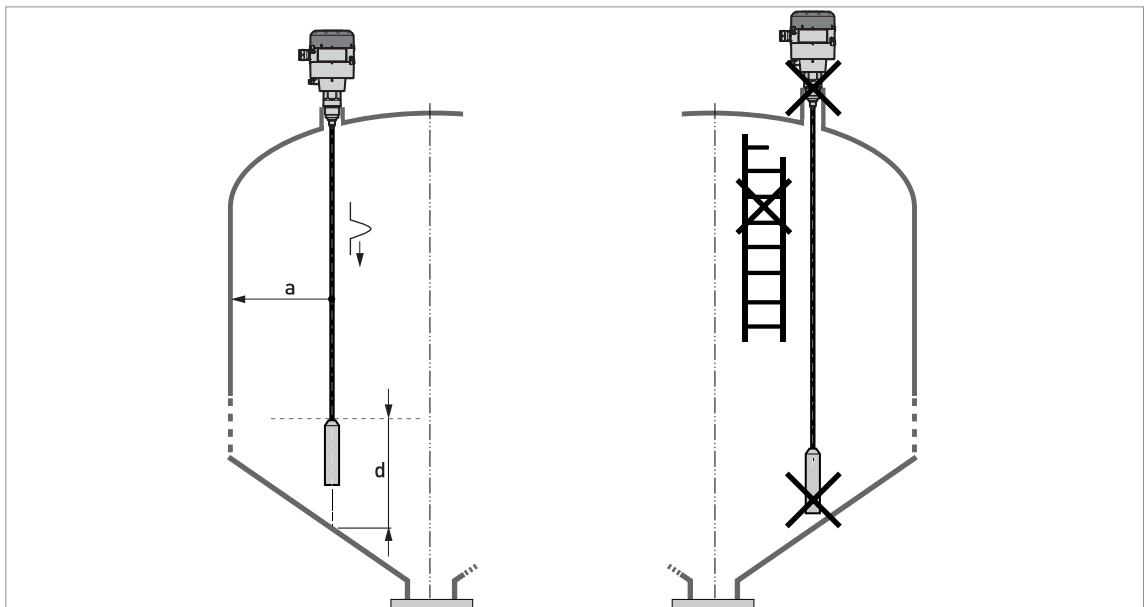

Figure 3-5: Installation recommendations for solids

$a \geq 300 \text{ mm} / 12''$

$d \geq 300 \text{ mm} / 12''$

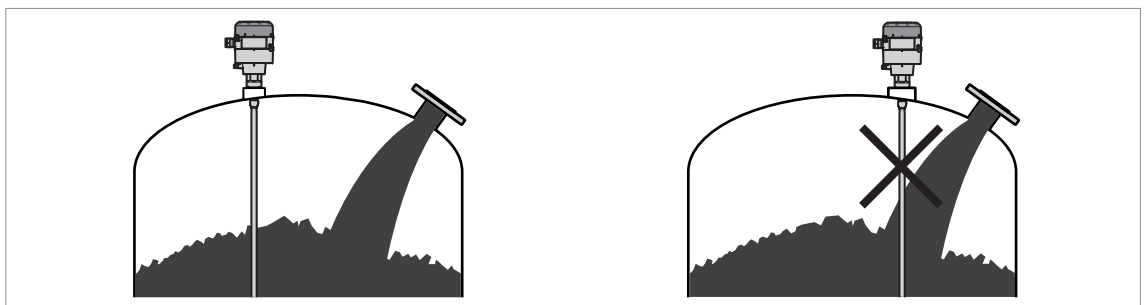

Figure 3-6: Do not install the probe near to a product inlet

4.1 Electrical installation: 2-wire, loop-powered

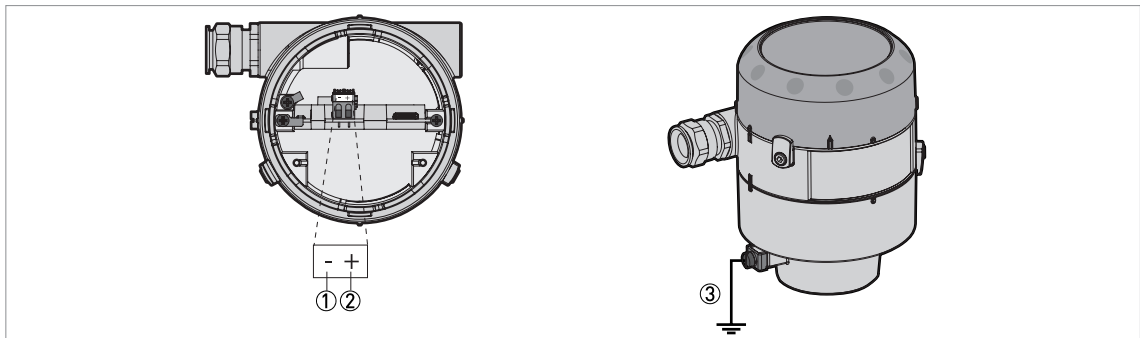

Figure 4-1: Terminals for electrical installation

- ① Current output -
- ② Current output +
- ③ Grounding terminal between the process connection and the converter

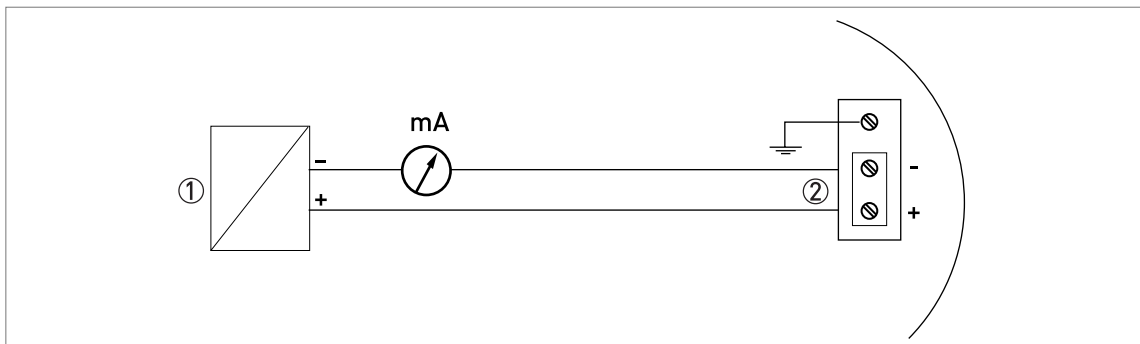

Figure 4-2: Electrical schematic

- ① Power supply
- ② Input: 14...30 VDC

5.1 Order code

The characters of the order code highlighted in light grey describe the standard.

VF25	4	OPTIFLEX 1100 C 2-wire loop-powered 4...20 mA Guided Radar (TDR) level meter: -50...+100°C and -1...16 barg / -58...212°F and -14.5...232 psig			
		Housing material			
	1	Aluminium			
		Probe type / probe length (probe material)			
	3	Single cable Ø2 mm / 0.08"; length 20 m / 65.6 ft (St. steel 316/1.4401)			
	6	Single cable Ø4 mm / 0.15"; length 10 m / 32.8 ft (St. steel 316/1.4401)			
	A	Coaxial; 1 segment; length <730 mm / 29" (St. steel 316L/1.4404)			
	B	Coaxial; 2 segments; length <1397 mm / 55" (St. steel 316L/1.4404)			
	C	Coaxial; 3 segments; length <2065 mm / 81" (St. steel 316L/1.4404)			
	D	Coaxial; 4 segments; length <2732 mm / 108" (St. steel 316L/1.4404)			
	E	Coaxial; 5 segments; length <3400 mm / 134" (St. steel 316L/1.4404)			
	F	Coaxial; 6 segments; length <4067 mm / 160" (St. steel 316L/1.4404)			
		Process connection			
	2	G ¾A (ISO 228)			
	3	G 1A (ISO 228)			
	5	¾ NPT (ASME B1.20.1)			
	6	1 NPT (ASME B1.20.1)			
		Cable entry / cable gland			
	1	M20 × 1.5 / plastic			
	2	½ NPT (Brass) / without			
		Display			
	1	Blind version			
	2	With an integrated display			
		Display language (English is supplied with all devices)			
	0	Without (for the blind version of the device)			
	1	English			
	2	German			
	3	French			
	4	Italian			
	5	Spanish			
	6	Portuguese			
	7	Japanese			
	8	Chinese (Mandarin)			
	A	Russian			
VF25	4	Order code			

Refer to the page that follows for accessory order codes.

Order codes for accessories

Description	Quantity	Part reference
HMI service tool ①	1	XF25410070X0 ②
Plastic strap wrench ③	2	XF2541000001

① Use only with devices without an integrated display

② The last "X" in the part reference refers to the display language. Use the Order Code table for the selection of the display language code.

③ For the removal of the housing cover







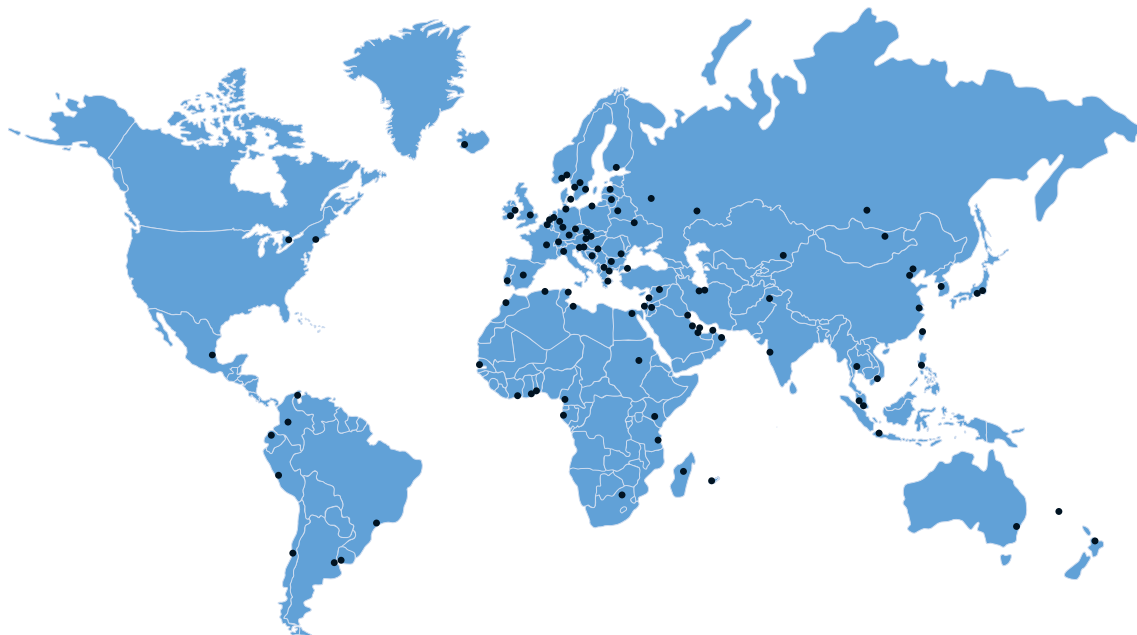

KROHNE product overview

- Electromagnetic flowmeters
- Variable area flowmeters
- Ultrasonic flowmeters
- Mass flowmeters
- Vortex flowmeters
- Flow controllers
- Level meters
- Temperature meters
- Pressure meters
- Analysis products
- Measuring systems for the oil and gas industry
- Measuring systems for sea-going tankers

Head Office KROHNE Messtechnik GmbH
Ludwig-Krohne-Str. 5
D-47058 Duisburg (Germany)
Tel.: +49 (0)203 301 0
Fax: +49 (0)203 301 10389
info@krohne.de

The current list of all KROHNE contacts and addresses can be found at:
www.krohne.com

KROHNE