



OPTIMASS 7000 Handbook

Sensor for mass flow

The documentation is only complete when used in combination with the relevant documentation for the signal converter.

All rights reserved. It is prohibited to reproduce this documentation, or any part thereof, without the prior written authorisation of KROHNE Messtechnik GmbH.

Subject to change without notice.

Copyright 2015 by
KROHNE Messtechnik GmbH - Ludwig-Krohne-Str. 5 - 47058 Duisburg (Germany)

1	Safety instructions	5
1.1	Software history	5
1.2	Intended use	5
1.3	CE certification	5
1.4	Associated documents	6
1.5	Pressure Equipment Directive (PED)	6
1.6	Dirty gas	7
1.7	Safety instructions from the manufacturer	7
1.7.1	Copyright and data protection	7
1.7.2	Disclaimer	8
1.7.3	Product liability and warranty	8
1.7.4	Information concerning the documentation	8
1.7.5	Warnings and symbols used	9
1.8	Safety instructions for the operator	9
2	Device description	10
2.1	Scope of delivery	10
2.1.1	Meters with hygienic connections	11
2.2	Nameplates	11
2.3	CSA Dual Seal	11
2.4	Temperature differential and thermal shock	12
3	Installation	14
3.1	General notes on installation	14
3.2	Storage	14
3.3	Handling	15
3.4	Installation conditions	17
3.4.1	Supporting the meter	17
3.4.2	Mounting the meter	18
3.4.3	Cross talk	19
3.4.4	Flange connections	19
3.4.5	Maximum pipework forces (end loadings)	20
3.4.6	Pipework reducers	20
3.4.7	Flexible connections	21
3.4.8	Hygienic installations	21
3.4.9	Heating and insulation	22
3.4.10	Purge ports	24
3.4.11	Zero calibration	25
3.4.12	Sunshades	26
4	Electrical connections	27
4.1	Safety instructions	27
4.2	Electrical and I/O connections	27

5 Service	28
5.1 Spare parts availability	28
5.2 Availability of services	28
5.3 Returning the device to the manufacturer	28
5.3.1 General information	28
5.3.2 Form (for copying) to accompany a returned device	29
5.4 Disposal	29
6 Technical data	30
6.1 Measuring principle (single tube)	30
6.2 Technical data	32
6.3 Measuring accuracy	38
6.4 Guidelines for maximum operating pressure	39
6.5 Dimensions and weights	43
6.5.1 Flanged versions	43
6.5.2 Hygienic versions	46
6.5.3 Heating jacket version	52
6.5.4 Purge port option	53
7 Notes	54

1.1 Software history

Release date	Software version	Documentation
Aug 2008	V2.2.xx	MA MFC 300 R02
		MA MFC 010 R03

1.2 Intended use

This mass flowmeter is designed for the direct measurement of mass flow rate, product density and product temperature. Indirectly, it also enables the measurement of parameters like total mass, concentration of dissolved substances and the volume flow. For use in hazardous areas, special codes and regulations are also applicable and these are specified in a separate documentation.



CAUTION!

Responsibility for the use of the measuring devices with regard to suitability, intended use and corrosion resistance of the used materials against the measured fluid lies solely with the operator.



INFORMATION!

This device is a Group 1, Class A device as specified within CISPR11:2009. It is intended for use in industrial environment. There may be potential difficulties in ensuring electromagnetic compatibility in other environments, due to conducted as well as radiated disturbances.



INFORMATION!

The manufacturer is not liable for any damage resulting from improper use or use for other than the intended purpose.

1.3 CE certification

CE marking



This device conforms with the following EC directives:

- EMC Directive 2004/108/EC
- ATEX Directive 94/9/EC
- Low Voltage Directive 2006/95/EC
- Pressure Equipment Directive 97/23/EC

The manufacturer declares conformity and the device carries the CE mark.

1.4 Associated documents

This handbook should be read in conjunction with relevant documents in relation to:

- hazardous areas
- communications
- concentration
- corrosion

1.5 Pressure Equipment Directive (PED)



LEGAL NOTICE!

The Pressure Equipment Directive places legal requirements on both the manufacturer and the end user. Please read this section carefully!

Visual check

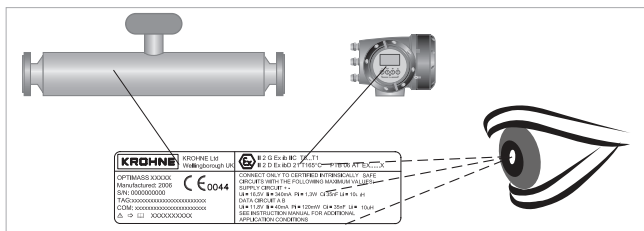

To ensure the PED integrity of the meter, you **MUST** check that the serial numbers on the converter nameplate and the sensor nameplate are the same.

To comply with the requirements of the Pressure Equipment Directive (PED) the manufacturer provides all the relevant technical data in the technical data section of this handbook. In addition to which, the following should also be noted:

- Secondary pressure containment is **NOT** supplied as standard.
- The non PED / CRN approved outer cylinder has a typical burst pressure greater than 100 barg / 1450 psig at 20°C / 68°F.
- The wiring feedthrough is made of Epoxy, PPS or PEEK with two O-rings made from FPM / FKM & Hydrogenated Nitrile.
- If the measuring tube/s fails, the O-ring and feedthrough will be in contact with the process product.
- You **MUST** make sure that the O-ring and feedthrough material is suitable for the application.
- Alternative O-ring materials are available on request.

Secondary pressure containment

Where the meter is being used to measure high pressure gases and / or gases kept as liquids by high pressure and / or where there is a risk of tube failure because of the use of corrosive or erosive fluids, frequent pressure and / or thermal cycling, seismic or other shock loading, a secondary containment option **MUST** be purchased

**DANGER!**

*If it is suspected that the primary measuring tube has failed, de-pressurise the meter and remove it from service as soon as it is safe to do so. Where the meter has a Tantalum primary measuring tube, extra care **MUST** be taken because the process fluid might be highly toxic and / or corrosive to the outer cylinder, wiring feedthrough and O-rings.*

1.6 Dirty gas

Dirty gas is gas that carries sand or other solid particles. Dirty gas causes excessive wear to the primary measuring tube that can eventually result in complete tube failure. In some situations tube failure where gas is being measured, can be very dangerous.

**DANGER!**

If the meter is being used to measure gas and there is a risk that the gas might be dirty, you must fit a filter upstream of the meter to catch solid particles.

1.7 Safety instructions from the manufacturer

1.7.1 Copyright and data protection

The contents of this document have been created with great care. Nevertheless, we provide no guarantee that the contents are correct, complete or up-to-date.

The contents and works in this document are subject to copyright. Contributions from third parties are identified as such. Reproduction, processing, dissemination and any type of use beyond what is permitted under copyright requires written authorisation from the respective author and/or the manufacturer.

The manufacturer tries always to observe the copyrights of others, and to draw on works created in-house or works in the public domain.

The collection of personal data (such as names, street addresses or e-mail addresses) in the manufacturer's documents is always on a voluntary basis whenever possible. Whenever feasible, it is always possible to make use of the offerings and services without providing any personal data.

We draw your attention to the fact that data transmission over the Internet (e.g. when communicating by e-mail) may involve gaps in security. It is not possible to protect such data completely against access by third parties.

We hereby expressly prohibit the use of the contact data published as part of our duty to publish an imprint for the purpose of sending us any advertising or informational materials that we have not expressly requested.

1.7.2 Disclaimer

The manufacturer will not be liable for any damage of any kind by using its product, including, but not limited to direct, indirect or incidental and consequential damages.

This disclaimer does not apply in case the manufacturer has acted on purpose or with gross negligence. In the event any applicable law does not allow such limitations on implied warranties or the exclusion of limitation of certain damages, you may, if such law applies to you, not be subject to some or all of the above disclaimer, exclusions or limitations.

Any product purchased from the manufacturer is warranted in accordance with the relevant product documentation and our Terms and Conditions of Sale.

The manufacturer reserves the right to alter the content of its documents, including this disclaimer in any way, at any time, for any reason, without prior notification, and will not be liable in any way for possible consequences of such changes.

1.7.3 Product liability and warranty

The operator shall bear responsibility for the suitability of the device for the specific purpose. The manufacturer accepts no liability for the consequences of misuse by the operator. Improper installation or operation of the devices (systems) will cause the warranty to be void. The respective "Standard Terms and Conditions" which form the basis for the sales contract shall also apply.

1.7.4 Information concerning the documentation

To prevent any injury to the user or damage to the device it is essential that you read the information in this document and observe applicable national standards, safety requirements and accident prevention regulations.

If this document is not in your native language and if you have any problems understanding the text, we advise you to contact your local office for assistance. The manufacturer can not accept responsibility for any damage or injury caused by misunderstanding of the information in this document.

This document is provided to help you establish operating conditions, which will permit safe and efficient use of this device. Special considerations and precautions are also described in the document, which appear in the form of icons as shown below.

1.7.5 Warnings and symbols used

Safety warnings are indicated by the following symbols.



DANGER!

This warning refers to the immediate danger when working with electricity.



DANGER!

This warning refers to the immediate danger of burns caused by heat or hot surfaces.



DANGER!

This warning refers to the immediate danger when using this device in a hazardous atmosphere.



DANGER!

These warnings must be observed without fail. Even partial disregard of this warning can lead to serious health problems and even death. There is also the risk of seriously damaging the device or parts of the operator's plant.



WARNING!

Disregarding this safety warning, even if only in part, poses the risk of serious health problems. There is also the risk of damaging the device or parts of the operator's plant.



CAUTION!

Disregarding these instructions can result in damage to the device or to parts of the operator's plant.



INFORMATION!

These instructions contain important information for the handling of the device.



LEGAL NOTICE!

This note contains information on statutory directives and standards.



• **HANDLING**

This symbol designates all instructions for actions to be carried out by the operator in the specified sequence.

➔ **RESULT**

This symbol refers to all important consequences of the previous actions.

1.8 Safety instructions for the operator



WARNING!

*In general, devices from the manufacturer may only be installed, commissioned, operated and maintained by properly trained and authorized personnel.
This document is provided to help you establish operating conditions, which will permit safe and efficient use of this device.*

2.1 Scope of delivery

Compact version

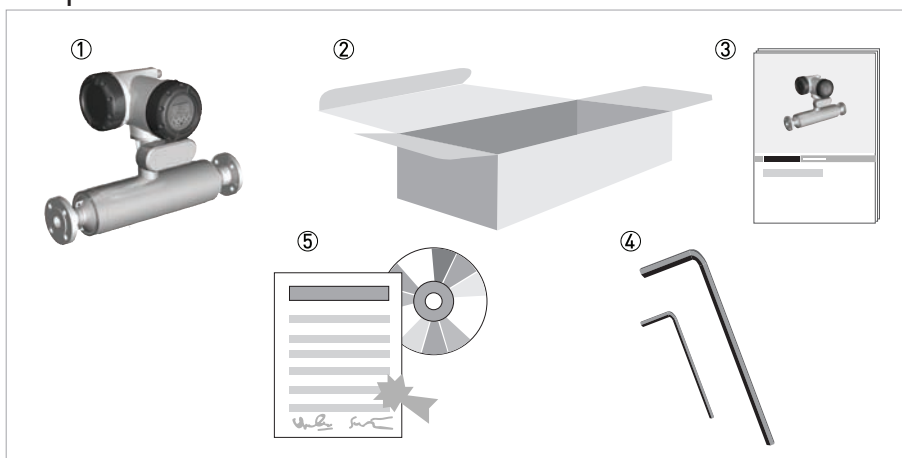

- ① Mass flowmeter.
- ② Carton.
- ③ Documentation.
- ④ 2.5 mm and 5 mm hex head tools.
- ⑤ CD-ROM and calibration certificate.

Remote version

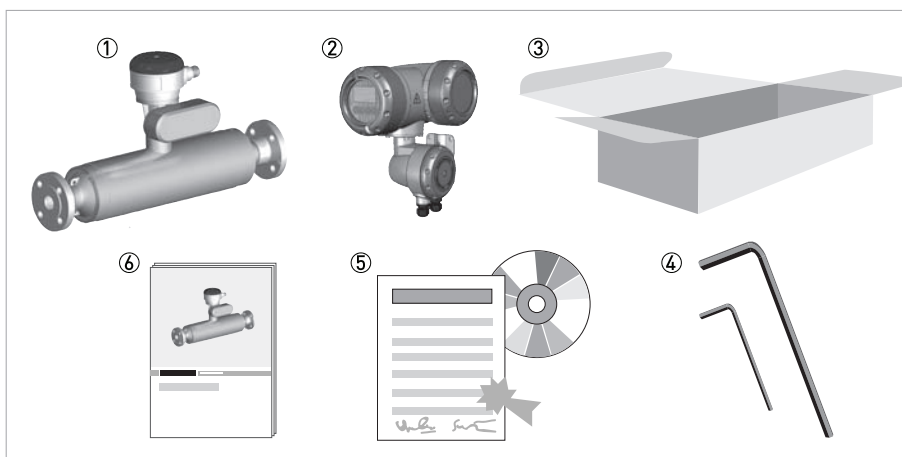

- ① Mass flowmeter.
- ② Converter. This will be either: field (as shown), wall or rack.
- ③ Carton.
- ④ 2.5 mm and 5 mm hex head tools.
- ⑤ CD-ROM and calibration certificate.
- ⑥ Documentation.

If any items are missing, please contact the manufacturer.

If your meter has flange connections, the flange specification is stamped on the outer edge of the flange. Check that the specification on the flange is the same as your order.

2.1.1 Meters with hygienic connections

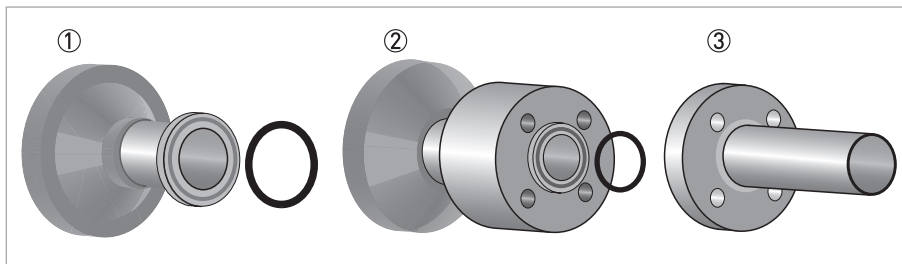

- ① Fully welded - the O-rings between the meter and the process pipework are not supplied as standard but can be ordered.
- ② DIN 11864-2 Form A - the O-rings between the Form A and Form B parts of the connection are not supplied as standard but can be ordered.
- ③ The 11864-2 Form B is not supplied as part of this connection but it can be ordered.

2.2 Nameplates



INFORMATION!

Look at the device nameplate to ensure that the device is delivered according to your order. Check for the correct supply voltage printed on the nameplate.

2.3 CSA Dual Seal

To comply with the requirements of ANSI/ISA -12.27.01-2003 "Requirements for process Sealing Between electrical systems and Flammable or Combustible process Fluids" a secondary seal is incorporated into all OPTIMASS / GAS products. If the primary seal fails, the secondary seal will prevent escaping fluid reaching the electronic compartment.

Pressures and / or temperatures are limited by tube, temperature, connection and Ex limits. Check the meter nameplates and relevant documentation for full details. On all meters operating on gas measurement, the casing of the meter is fitted with a burst disc. If the primary seal (tube) fails leakage will occur from the burst disc. Install the meter so that the burst disc is pointing away from personnel.

Liquids (Example model code: OPTIMASS 7000C S25)

Pressure and temperature data:

OPTIMASS 7000 / 7300 / 7010 -40°C...+150°C and 100...10000 kPa

Pressures and/or temperatures may be further limited by tube, temperature, connection and Ex limits. Consult the meter nameplate and relevant documentation for full details

If the primary seal fails, the casing of the meter will fill with liquid and the meter will stop working. The meter will notify the operator by going into <Startup> mode and a diagnostic error will be shown on the converter or PLC display. This is an indication that the primary seal (tube) has failed and the status of the meter should be checked.

Meter status:

The meter will also go into <Startup> mode if the primary seal (tube) fails, or if they are not completely filled with fluid. For example, if the meter is drained or re/filled.

To check the status of the meter, drain and re/fill with fluid and note the converter or PLC display. See the relevant section of the converter handbook for a list of status messages and diagnostics information.

If the meter remains in <Startup> mode you MUST assume that the primary seal (tube) has failed and the appropriate action MUST be taken.

Gases (Example model code: OPTIMASS 7000C S25)

Pressure / temperature data:

OPTIMASS 7000 / 7300 / 7010 -40°C...+150°C and 500...10000 kPa

Pressures and/or temperatures may be further limited by tube, temperature, connection and Ex limits. Consult the meter nameplate and relevant documentation for full details.

On all meters operating on gas measurement the casing of the meter is fitted with a burst disc. If the primary seal (tube/s) fails leakage will occur from the burst disc. Install the meter so that the burst disc is pointing away from personnel.

Regular maintenance of the burst disc:

Carry out regular maintenance checks on burst discs for leakage and/or blockages. On all OPTIMASS meters, the primary seal is considered to be the measuring tube of the meter. The materials of construction of the measuring tube/s are described within the relevant sections of this handbook and the customer's product and any other fluid flowing through the tube must be compatible with the material of construction. If failure of the primary seal is suspected then the process line should be de-pressurised and the meter removed as soon as it is safe to do so. Please contact customer service for servicing or replacement of the meter.

2.4 Temperature differential and thermal shock

Temperature differential

The maximum difference between ambient temperature and process (operating) temperature varies according to the measuring tube material.

Meter	Maximum temperature differential
Titanium	+130°C / +266°F
Stainless Steel	+80°C / +176°F
Hastelloy	+80°C / +176°F
Tantalum	+80°C / +176°F

Extended range

Stainless Steel meters sizes 25, 40, 50 and 80 (fitted with hygienic connections) may be exposed to a temperature difference of 110°C / 230°F for a maximum of 2 hours.

Thermal shock

Thermal shock occurs when there is a sudden and extreme change (shift) in process temperature. To avoid thermal shock, refer to the following table for the maximum temperature shift.

Meter	Maximum temperature shift
Titanium	+130°C / +266°F
Stainless Steel	+80°C / +176°F
Hastelloy®	+80°C / +176°F
Tantalum	+80°C / +176°F



CAUTION!

Operation outside these limits may result in shifts in density and mass flow calibration. Repeated shocking may also lead to premature failure of the meter! However, higher thermal shocks are possible at lower working pressures. For more information, please contact your nearest representative.

3.1 General notes on installation

**INFORMATION!**

Inspect the packaging carefully for damages or signs of rough handling. Report damage to the carrier and to the local office of the manufacturer.

**INFORMATION!**

Do a check of the packing list to make sure that you have all the elements given in the order.

**INFORMATION!**

Look at the device nameplate to ensure that the device is delivered according to your order. Check for the correct supply voltage printed on the nameplate.

3.2 Storage

- Store the device in a dry and dust-free location.
- Avoid direct exposure to the sun.
- Store the device in its original packing.
- Do not allow the ambient temperature to fall below -50°C / -58°F or rise above $+85^{\circ}\text{C}$ / $+185^{\circ}\text{F}$.

3.3 Handling

Using a sling to lift and carry the meter

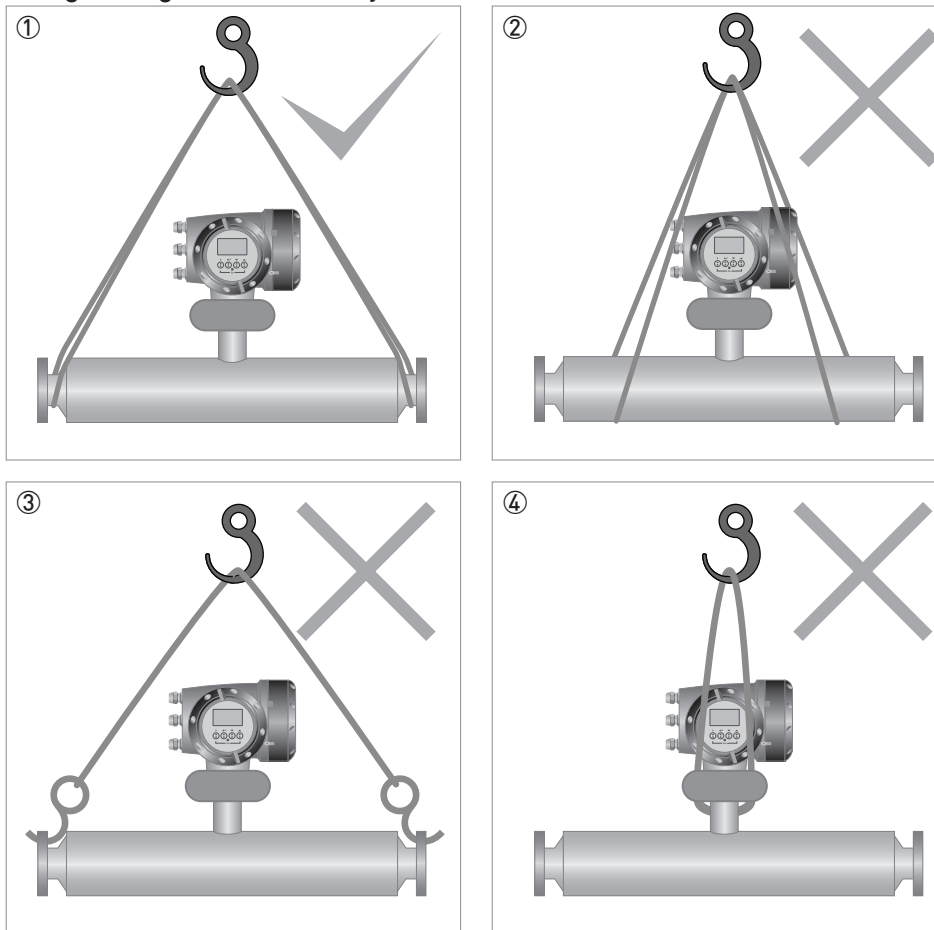

- ① Use a well maintained sling to lift the meter by the spigots.
- ② DO NOT lift the meter with the sling part way along the outer cylinder.
- ③ DO NOT lift the meter using the flange bolt holes.
- ④ DO NOT lift the meter by the converter housing or the electronics stem.

Standing the meter before installation

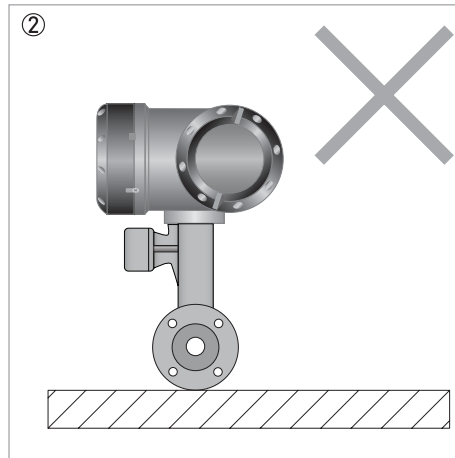
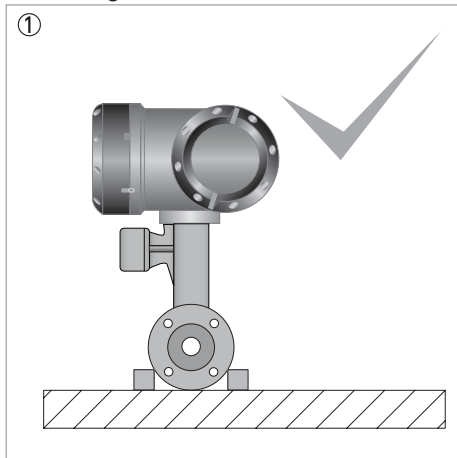

- ① When standing the meter prior to installation, use blocks or similar to keep the meter upright.
- ② NEVER stand the meter upright without blocks (or similar) .

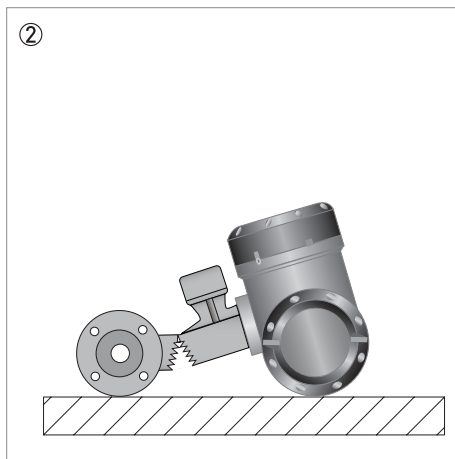
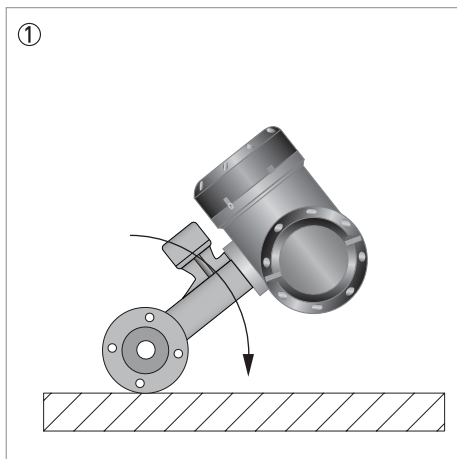

- ① If the meter is not blocked it can roll over
- ② This can cause severe damage to the meter, or injury to personnel

3.4 Installation conditions

3.4.1 Supporting the meter

Support for meters with flange connections

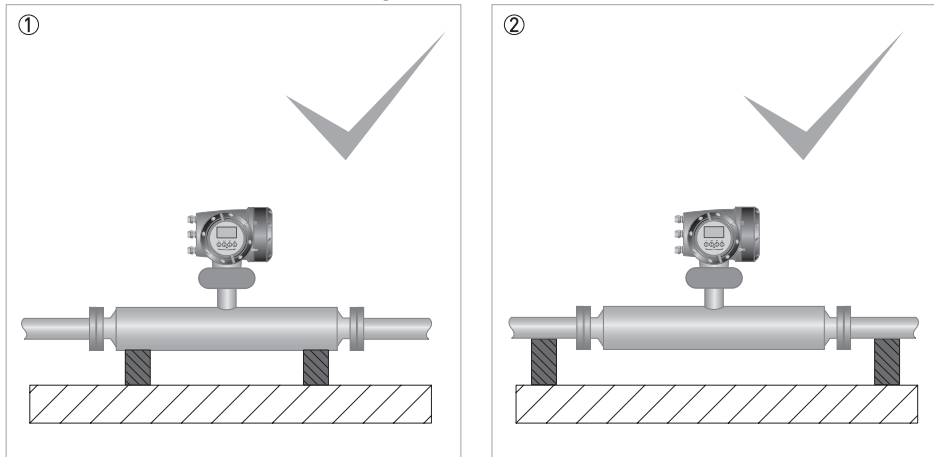

- ① The meter can be supported directly by its body
- ② The meter can also be supported by the process pipework

Support for meters with hygienic connections

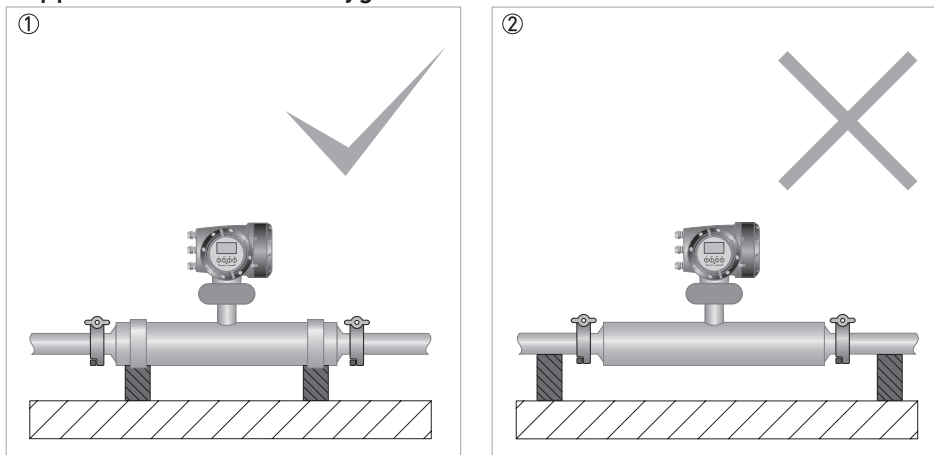

- ① Always support the meter body.
- ② DO NOT use the process pipework to support the weight of the meter. The thin wall of the pipework usually used in the hygienic industry, is not strong enough to carry the weight of the meter.



CAUTION!

If there is excessive vibration in the process pipework, you must isolate the meter from its mounting. It is recommended that you place an insert made from rubber (or similar material) between the meter body, or pipework, and the mounting clamp or fixing point. For more information, contact the manufacturer.

3.4.2 Mounting the meter

Mounting positions

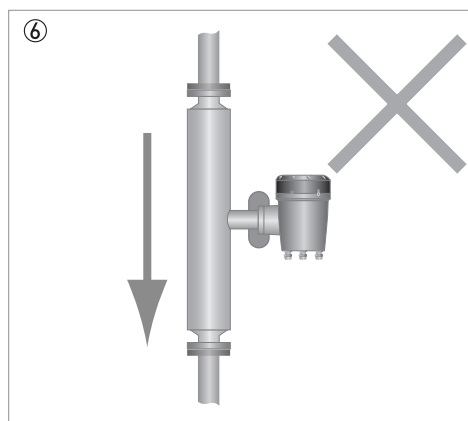
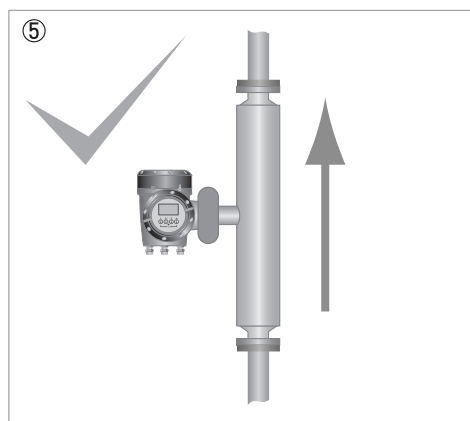
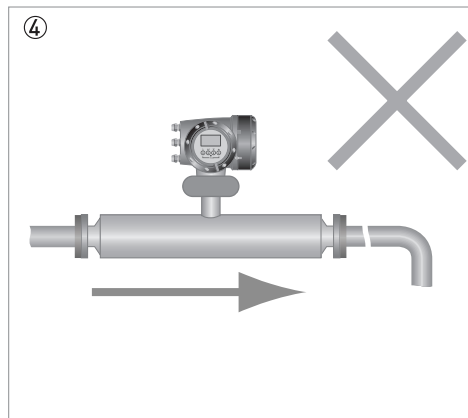
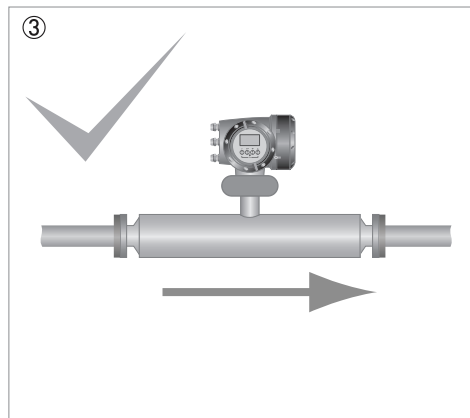
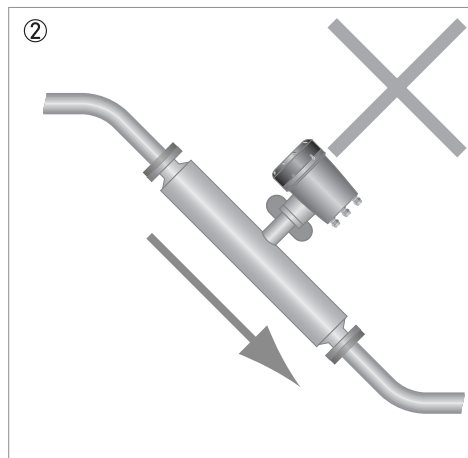
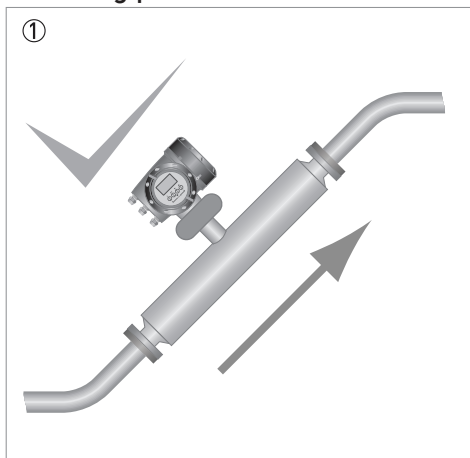

- ① The meter can be mounted at an angle but it is recommended that the flow is uphill.
- ② Avoid mounting the meter with the flow running downhill because it can cause siphoning. If the meter has to be mounted with the flow running downhill, install an orifice plate or control valve downstream of the meter to maintain backpressure.
- ③ Horizontal mounting with flow running left to right.
- ④ Avoid mounting meter with long vertical runs after the meter as it can cause cavitation. Where the installation includes a vertical run after the meter, install an orifice plate or control valve downstream to maintain backpressure.
- ⑤ The meter can be mounted vertically but it is recommended that the flow is uphill.
- ⑥ Avoid mounting the meter vertically with the flow running downhill. This can cause siphoning. If the meter has to be installed this way, install an orifice plate or control valve downstream to maintain backpressure.

3.4.3 Cross talk

Where more than one meter is being installed, a very high level of immunity to cross talk means that the meters can be mounted within close proximity to each other. The meters can be mounted either in series or parallel, as shown.

Meters in series

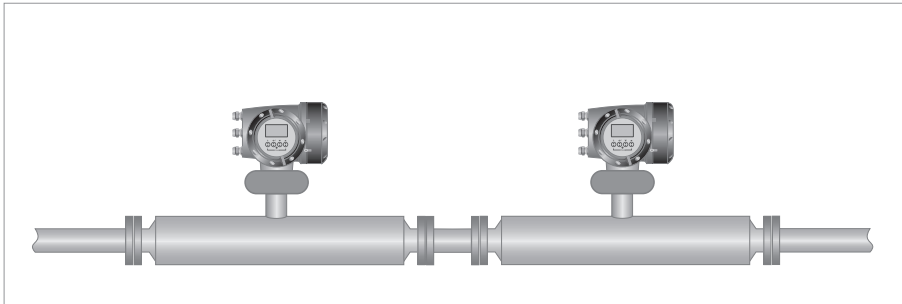

INFORMATION!

Where the meters are installed in series, it is strongly recommended that the process pipe diameter remains constant. For more information, please contact the manufacturer.

Meters in parallel

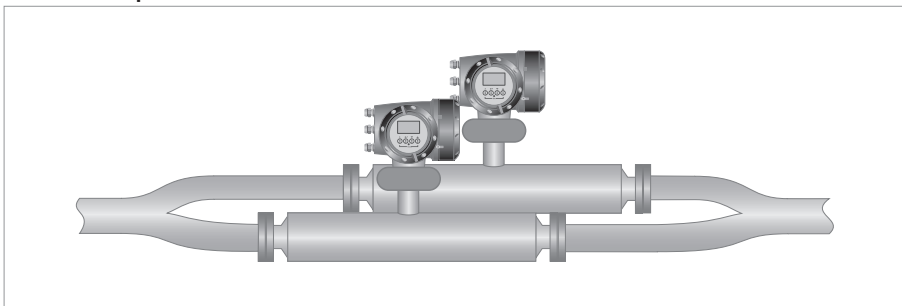

3.4.4 Flange connections

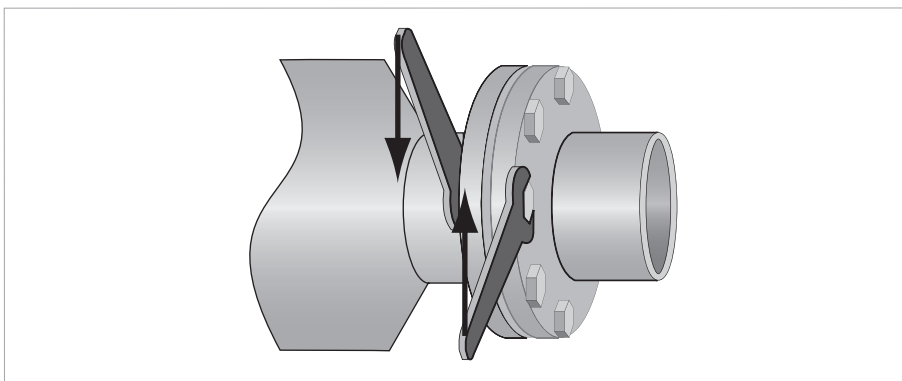

Tighten the flange bolts evenly and in turn.

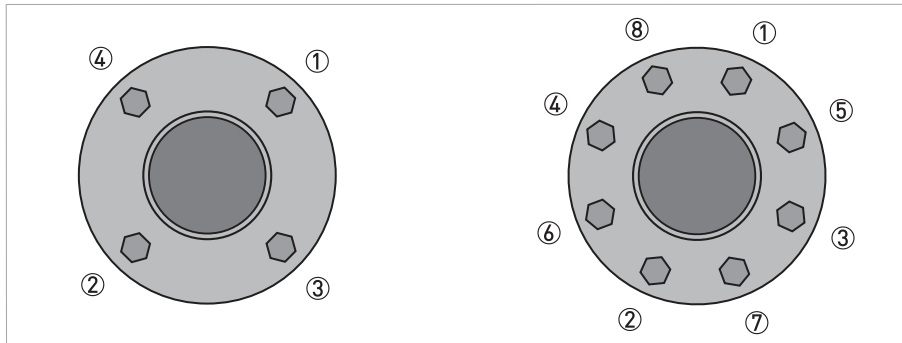

Use a regular pattern to tighten the bolts evenly

3.4.5 Maximum pipework forces (end loadings)

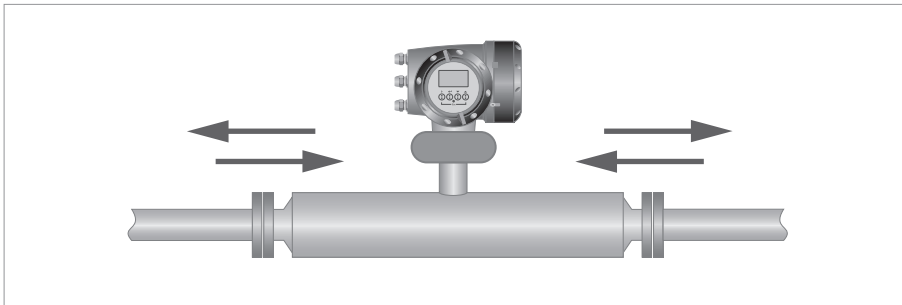

Mass flowmeters have a maximum level of force (negative or positive) that can be applied to the ends of the meter. Refer to the table below for permitted forces.

Please refer to the table in the technical data section of this Handbook for the maximum end loadings.

3.4.6 Pipework reducers

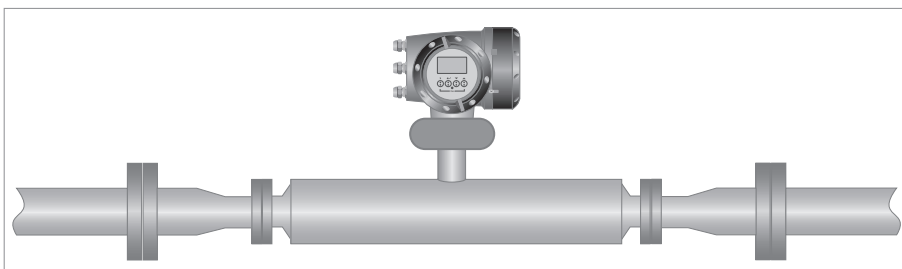

Always avoid extreme step changes in pipe size. Use pipework reducers, where there is a large difference between pipework size and meter flanges.

3.4.7 Flexible connections

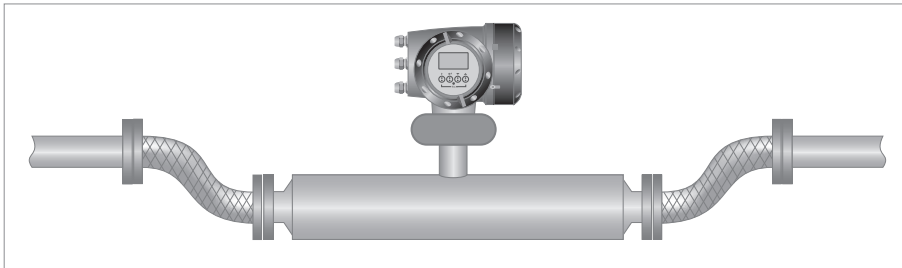

Flexible connections can be used but because of the high flow rates associated with large diameter meters, it is recommended that flexible connections are not used on meters larger than size 80.

3.4.8 Hygienic installations

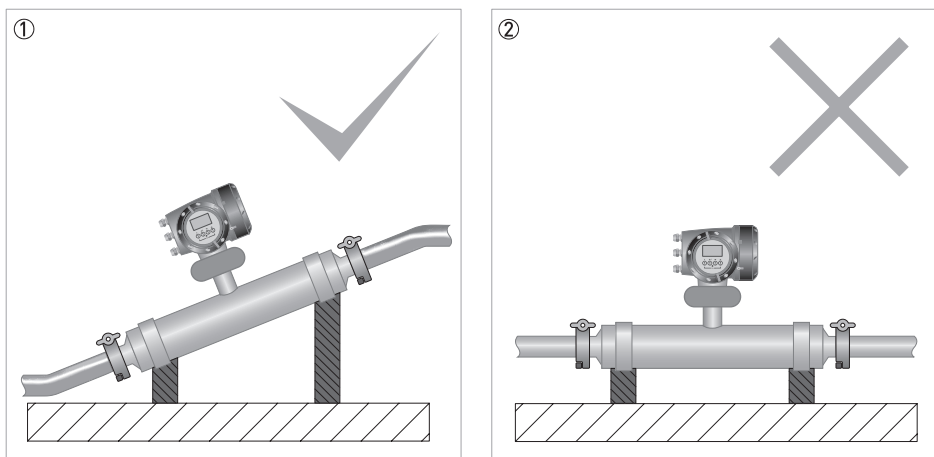

- ① Install the meter at an angle to allow self-draining.
- ② DO NOT install the meter horizontally.

Where the meter has been approved by the sanitary requirements of the European Hygienic Engineering and Design Group, you **MUST** give consideration to:

- Installation - install the meter at an angle to allow self-draining (see illustration).
- Cleaning fluids - cleaning fluids should flow uphill with a velocity rate greater than 1.5 m/s / 5ft/s. If the process flow is downhill, install a flow restrictor downstream of the meter. This will make sure that the meter is completely filled with the cleaning fluid.
- Process connections and seals **MUST** be in accordance with EHEDG documentation.

The manufacturer also recommends that you refer to EHEDG (www.ehedg.org) document number 8 "HYGIENIC EQUIPMENT DESIGN CRITERIA".

3.4.9 Heating and insulation

Heating

The meter can be heated by electrical tape (or similar) as shown. ONLY heat the meter in the area marked A.

Insulation

The meter can also be insulated to a maximum depth as shown (B). Do not insulate above this depth as this will cause the electronics to overheat.

Electrical heating and insulation

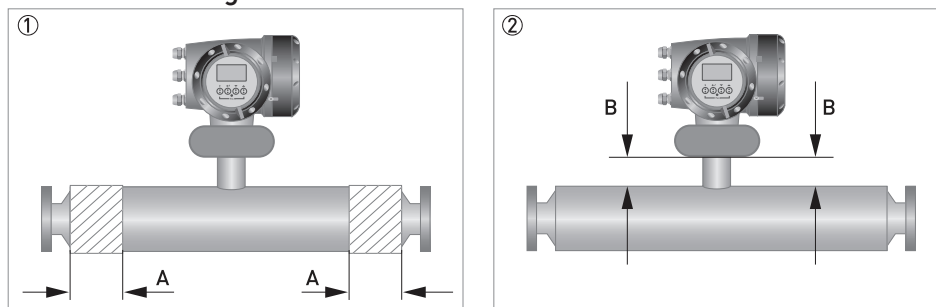

- ① Area that can be heated (A). Refer to the table for the maximum sizes.
- ② Maximum depth of insulation (B). DO NOT insulate above this depth.

Heated area

Dimension of A [mm]	10	15	25	40	50	80
Titanium	50	65	120	150	200	410
Stainless Steel / Hastelloy® / Tantalum	-	65	75	150	125	225
Dimension of A [inches]	10	15	25	40	50	80
Titanium	1.97	2.56	4.7	5.9	7.9	16.1
Stainless Steel / Hastelloy® / Tantalum	-	2.56	2.9	5.9	4.9	8.8

Factory fitted heating jacket

If the meter has been ordered with a heating jacket, it will be supplied with NPT, Ermeto or flange connections.

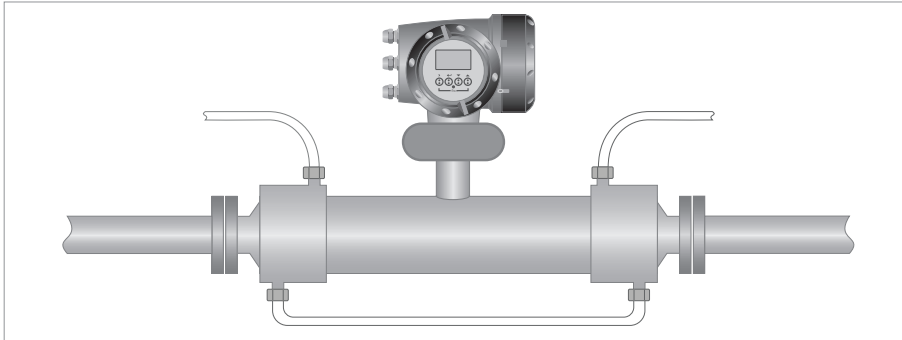

Connecting / using the heating jacket

- Use reinforced flexible hoses to connect the heating jacket to the heat source.
- The heating jacket material is 316L but the heating medium is also in contact with the outer cylinder, which might be a lower grade Stainless Steel.
- Suitable heating mediums are steam or hot oil. Avoid the use of heating mediums that can cause crevice corrosion in Stainless Steel.
- Where liquid is being used, set up the pipe configuration so that air can be vented from the system.
- Where steam is being used, set up the pipe configuration so that condensation can be drained off.
- Heat the jacket to working temperature before flowing the process fluid through the meter.



CAUTION!

The maximum heating jacket pressure and temperature is 10 barg at 150°C / 145 psig at 302°F for Titanium measuring tubes and 10 barg at 100°C / 145 psig at 212°C for Stainless Steel, Hasteloy and Tantalum measuring tubes.

Heating times

Temperature [°C / °F] ①	Time [minutes] for Titanium measuring tube					
	10	15	25	40	50	80
40 / 104		30			90	
60 / 140		80			160	
80 / 176		120			330	
100 / 212		190			495	
120 / 248		270			735	
140 / 284		480			1320	
① Measured at the centre of the measuring tube.						

Temperature [°C / °F] ①	Time [minutes] for Stainless Steel, Hastelloy® and Tantalum measuring tubes					
	10	15	25	40	50	80
40 / 104		105			90	
60 / 140		190			240	
80 / 176		330			480	
100 / 212		495			800	
① Measured at the centre of the measuring tube.						

Reference conditions

Ambient temperature	+25°C / +80°F
Heating medium	Hot liquid
Heating medium temperature	
Titanium	+150°C / +302°F
Stainless Steel, Hastelloy® and Tantalum	+100°C / +212°F

3.4.10 Purge ports

If the meter has been ordered with a purge port, it will be supplied with NPT female connections which are clearly marked. The connections are sealed with NPT plugs and PTFE tape.



CAUTION!

DO NOT remove these plugs.

The meter is factory sealed with a dry nitrogen gas fill and if moisture is allowed to enter the meter casing it will cause damage. The plugs should only be removed to purge the meter casing in the event that the primary measuring tube fails.

If it is suspected that the primary measuring tube has failed, de-pressurise the meter and remove it from service, as soon as it is safe to do so.

3.4.11 Zero calibration

The procedure for zero calibration is contained in the converter handbook. However, the following information should be considered when installing the meter.

Zero calibration

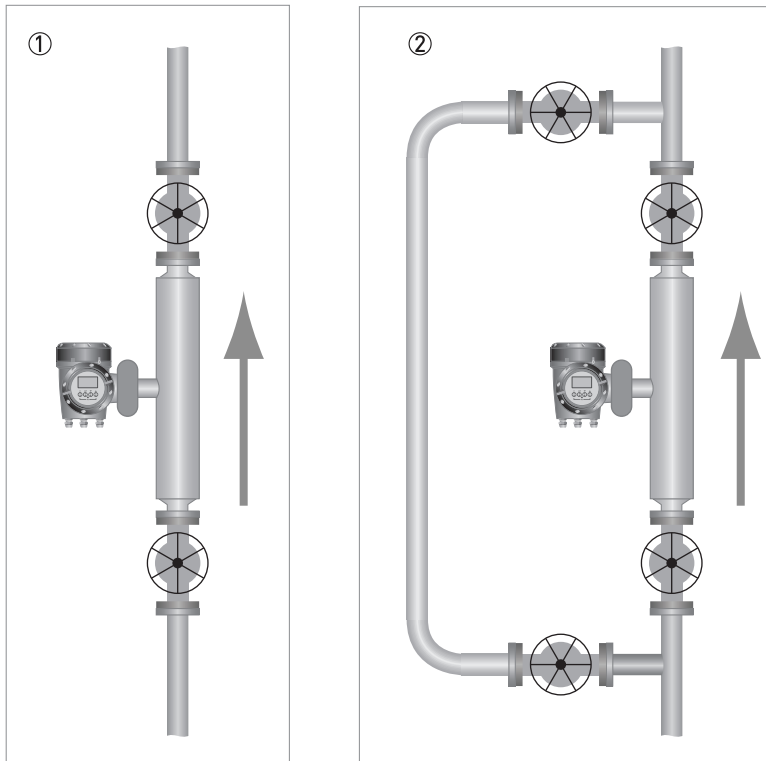

- ① Where the meter has been installed vertically, install shut-off valves either side of the meter to assist with zero calibration.
- ② If the process flow cannot be stopped, install a bypass section for zero calibration.

3.4.12 Sunshades

The meter MUST be protected from strong sunlight.

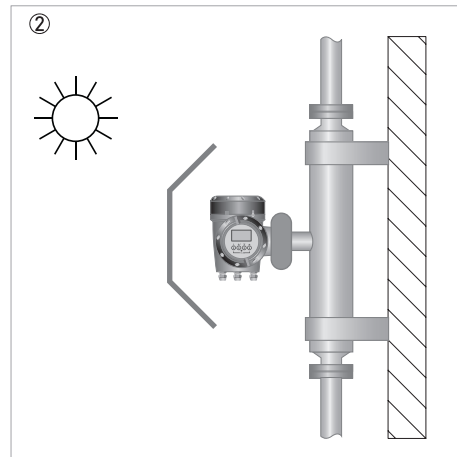
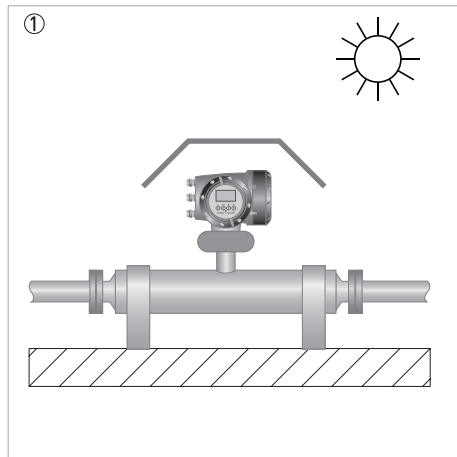

- ① Horizontal installation
- ② Vertical installation

4.1 Safety instructions

**DANGER!**

All work on the electrical connections may only be carried out with the power disconnected. Take note of the voltage data on the nameplate!

**DANGER!**

Observe the national regulations for electrical installations!

**DANGER!**

For devices used in hazardous areas, additional safety notes apply; please refer to the Ex documentation.

**WARNING!**

Observe without fail the local occupational health and safety regulations. Any work done on the electrical components of the measuring device may only be carried out by properly trained specialists.

**INFORMATION!**

Look at the device nameplate to ensure that the device is delivered according to your order. Check for the correct supply voltage printed on the nameplate.

4.2 Electrical and I/O connections

For information regarding electrical and I/O connections, please refer to the handbook for the relevant signal converter.

5.1 Spare parts availability

The manufacturer adheres to the basic principle that functionally adequate spare parts for each device or each important accessory part will be kept available for a period of 3 years after delivery of the last production run for the device.

This regulation only applies to spare parts which are subject to wear and tear under normal operating conditions.

5.2 Availability of services

The manufacturer offers a range of services to support the customer after expiration of the warranty. These include repair, maintenance, technical support and training.



INFORMATION!

For more precise information, please contact your local sales office.

5.3 Returning the device to the manufacturer

5.3.1 General information

This device has been carefully manufactured and tested. If installed and operated in accordance with these operating instructions, it will rarely present any problems.



CAUTION!

Should you nevertheless need to return a device for inspection or repair, please pay strict attention to the following points:

- *Due to statutory regulations on environmental protection and safeguarding the health and safety of the personnel, the manufacturer may only handle, test and repair returned devices that have been in contact with products without risk to personnel and environment.*
- *This means that the manufacturer can only service this device if it is accompanied by the following certificate (see next section) confirming that the device is safe to handle.*



CAUTION!

If the device has been operated with toxic, caustic, flammable or water-endangering products, you are kindly requested:

- *to check and ensure, if necessary by rinsing or neutralising, that all cavities are free from such dangerous substances,*
- *to enclose a certificate with the device confirming that it is safe to handle and stating the product used.*

5.3.2 Form (for copying) to accompany a returned device



CAUTION!

To avoid any risk for our service personel, this form has to be accessible from outside of the packaging with the returned device.

Company:		Address:	
Department:		Name:	
Tel. no.:		Fax no. and/or Email address:	
Manufacturer's order no. or serial no.:			
The device has been operated with the following medium:			
This medium is:	<input type="checkbox"/>	radioactive	
	<input type="checkbox"/>	water-hazardous	
	<input type="checkbox"/>	toxic	
	<input type="checkbox"/>	caustic	
	<input type="checkbox"/>	flammable	
	<input type="checkbox"/>	We checked that all cavities in the device are free from such substances.	
	<input type="checkbox"/>	We have flushed out and neutralized all cavities in the device.	
We hereby confirm that there is no risk to persons or the environment through any residual media contained in the device when it is returned.			
Date:		Signature:	
Stamp:			

5.4 Disposal



CAUTION!

Disposal must be carried out in accordance with legislation applicable in your country.

Separate collection of WEEE (Waste Electrical and Electronic Equipment) in the European Union:



According to the directive 2012/19/EU, the monitoring and control instruments marked with the WEEE symbol and reaching their end-of-life **must not be disposed of with other waste.**

The user must dispose of the WEEE to a designated collection point for the recycling of WEEE or send them back to our local organisation or authorised representative.

6.1 Measuring principle (single tube)

Static meter not energised and with no flow

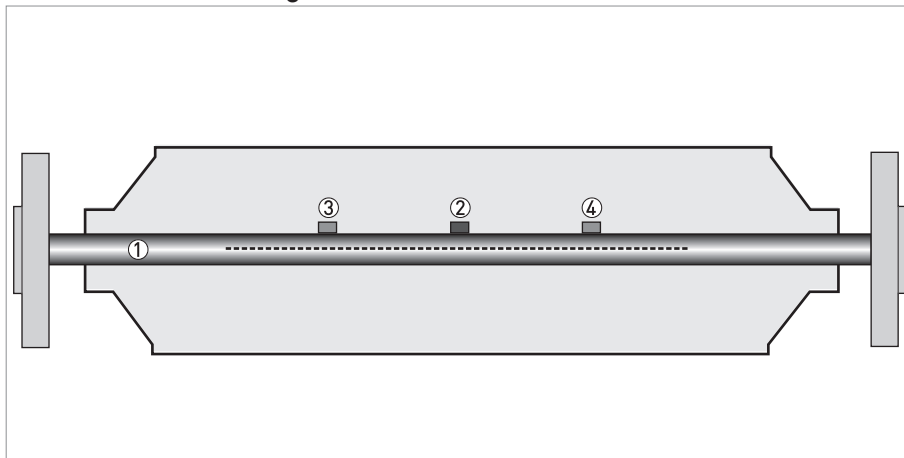

- ① Measuring tube
- ② Drive coil
- ③ Sensor 1
- ④ Sensor 2

A Coriolis single tube mass flowmeter consists of a single measuring tube ① a drive coil ② and two sensors (③ and ④) that are positioned either side of the drive coil.

Energised meter

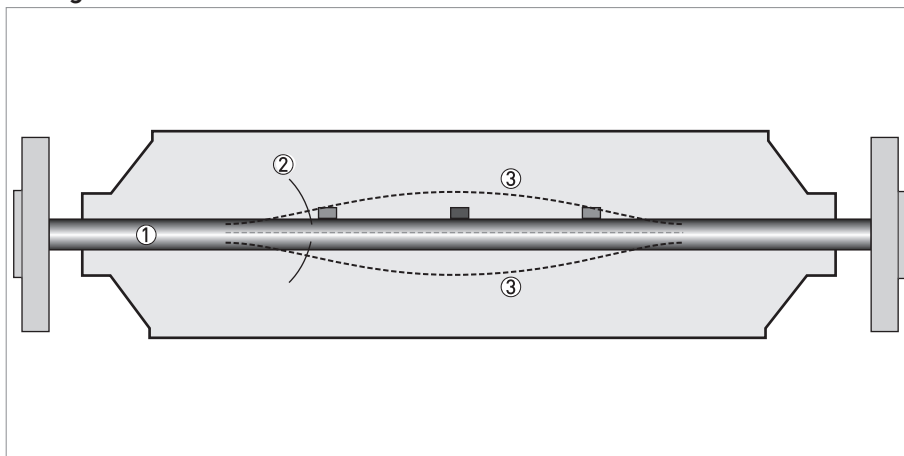

- ① Measuring tubes
- ② Direction of oscillation
- ③ Sine wave

When the meter is energised, the drive coil vibrates the measuring tube causing it to oscillate and produce a sine wave ③. The sine wave is monitored by the two sensors.

Energised meter with process flow

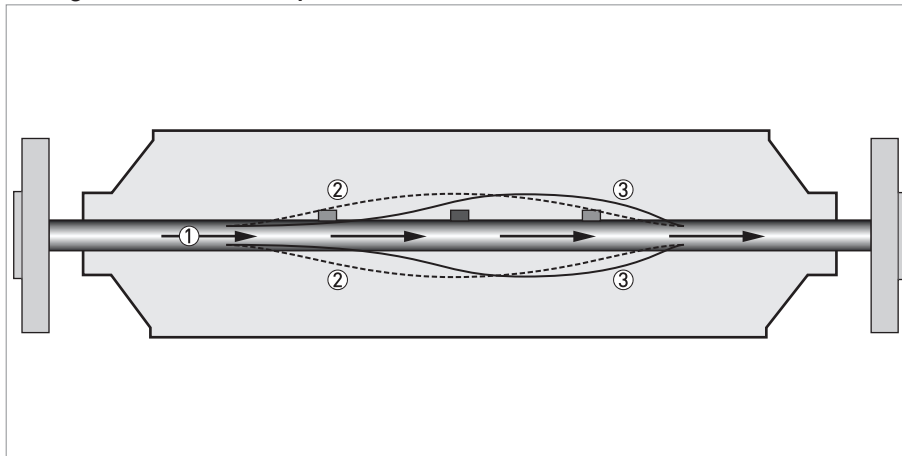

- ① Process flow
- ② Sine wave
- ③ Phase shift

When a fluid or gas passes through the tube, the coriolis effect causes a phase shift in the sine wave that is detected by the two sensors. This phase shift is directly proportional to the mass flow.

Density measurement is made by evaluation of the frequency of vibration and temperature measurement is made using a Pt500 sensor.

6.2 Technical data



INFORMATION!

- The following data is provided for general applications. If you require data that is more relevant to your specific application, please contact us or your local sales office.
- Additional information (certificates, special tools, software,...) and complete product documentation can be downloaded free of charge from the website (Downloadcenter).

Measuring system

Measuring principle	Coriolis mass flow
Application range	Mass flow and density measurement of fluids, gases and solids
Measured values	Mass, density, temperature
Calculated values	Volume, referred density, concentration, velocity

Design

Basic	System consists of a measuring sensor and a converter to process the output signal
Features	Fully welded maintenance free sensor with single straight measuring tube
Variants	
Compact version	Integral converter
Remote version	Available with field, wall or 19" rack mount versions of the converter
Modbus version	Sensor with integral electronics providing Modbus output for connection to a PLC

Measuring accuracy

Mass	
Liquid	±0.1% of actual measured flow rate + zero stability
Gas	±0.35% of actual measured flow rate + zero stability
Repeatability	Better than 0.05% plus zero stability (includes the combined effects of repeatability, linearity and hysteresis)
Zero stability	
Titanium	±0.004% of maximum flow rate with respective sensor size
Stainless Steel / Hastelloy® / Tantalum	±0.015% of maximum flow rate with respective sensor size
Reference conditions	
Product	Water
Temperature	+20°C / +68°F
Operating pressure	1 barg / 14.5 psig
Effect on sensor zero point caused by a shift in process temperature	
Titanium	0.001% per 1°C / 0.00055% per 1°F
Stainless Steel / Hastelloy® / Tantalum	0.004% per 1°C / 0.0022% per 1°F
Effect on sensor zero point caused by a shift in process pressure	
Titanium / Stainless Steel / Hastelloy® / Tantalum	0.0011% of the max flow rate per 1 bar _{rel.} / 0.000076% per 1 psig
Density	
Measuring range	400...2500 kg/m ³ / 25...155 lbs/ft ³

Accuracy	$\pm 2 \text{ kg/m}^3 / \pm 0.13 \text{ lbs/ft}^3$
On site calibration	$\pm 0.5 \text{ kg/m}^3 / \pm 0.033 \text{ lbs/ft}^3$
Temperature	
Accuracy	$\pm 1^\circ\text{C} / \pm 1.8^\circ\text{F}$

Operating conditions

Maximum flow rates	
06	1230 kg/h / 45 lbs/min
10	3500 kg/h / 129 lbs/min
15	14600 kg/h / 536 lbs/min
25	44800 kg/h / 1646 lbs/min
40	120000 kg/h / 4409 lbs/min
50	234000 kg/h / 8598 lbs/min
80	560000 kg/h / 20567 lbs/min
Ambient temperature	
Compact version with Aluminium converter	-40...+60°C / -40...+140°F
	Extended temperature range +65°C / +149°F for some I/O options. For more information contact manufacturer
Compact version with Stainless Steel converter	-40...+55°C / -40...+130°F
Remote versions	-40...+65°C / -40...+149°F
Process temperature	
Titanium	-40...+150°C / -40...+302°F
Stainless Steel	0...+100°C / 32...+212°F
	Extended temperature range 0...+130°C / 32...+266°F on Stainless Steel, sizes 25...80, hygienic connections only
Hastelloy®	0...+100°C / 32...+212°F
Tantalum	0...+100°C / 32...+212°F
Nominal pressure at 20°C / 68°F	
Measuring tube	
Titanium	-1...100 barg / -14.5...1450 psig
Stainless Steel / Hastelloy® / Tantalum	-1...50 barg / -14.5...725 psig
Outer cylinder	
Non PED / CRN approved	Typical burst pressure > 100 barg / 1450 psig at 20°C
PED approved secondary containment	
Titanium (Stainless Steel 304 or 316 outer cylinder)	-1...63 barg / -14.5...910 psig
Titanium (Stainless Steel 316 outer cylinder)	-1...100 barg / -14.5...1450 psig
Stainless Steel / Hastelloy® (Stainless Steel 304 or 316 outer cylinder)	-1...63 barg / -14.5...910 psig
Tantalum (316 outer cylinder)	-1...50 barg / -14.5...725 psig
CRN approved secondary containment	
Titanium (Stainless Steel 304 or 316 outer cylinder)	-1...63 barg / -14.5...910 psig
Stainless Steel / Hastelloy® (Stainless Steel 304 or 316 outer cylinder)	-1...63 barg / -14.5...910 psig

Fluid properties	
Permissible physical condition	Liquids, gases, slurries
Permissible gas content (volume)	Contact manufacturer for information
Permissible solid content (volume)	Contact manufacturer for information
Other operating conditions	
Protection category (acc. to EN 60529)	IP 67, NEMA 4X

Installation conditions

Inlet runs	None required
Outlet runs	None required

Materials

Titanium meter	
Measuring tube / raised faces	Titanium grade 9 / grade 2
Flanges	Stainless Steel 316 / 316L (1.4401 / 1.4404) dual certified
Outer cylinder	Stainless Steel 304 / 304L (1.4301 / 1.4307) dual certified
	Optional Stainless Steel 316 / 316L (1.4401 / 1.4404) dual certified
Stainless Steel meter	
Measuring tube / raised faces	Stainless Steel UNS S31803 (1.4462)
Flanges	Stainless Steel 316 / 316L (1.4401 / 1.4404) dual certified
Outer cylinder	Stainless Steel 304 / 304L (1.4301 / 1.4307) dual certified
	Optional Stainless Steel 316 / 316L (1.4401 / 1.4404) dual certified
Hastelloy® meter	
Measuring tube / raised faces	Hastelloy® C-22
Flanges	Stainless Steel 316 / 316L (1.4401 / 1.4404) dual certified
Outer cylinder	Stainless Steel 304 / 304L (1.4301 / 1.4307) dual certified
	Optional Stainless Steel 316 / 316L (1.4401 / 1.4404) dual certified
Tantalum meter	
Measuring tube / raised faces	UNS R05255 / R05200
Flanges	Stainless Steel 316 / 316L (1.4401 / 1.4404) dual certified
Outer cylinder	Stainless Steel 316 / 316L (1.4401 / 1.4404) dual certified
Heating jacket version	
Heating jacket	Stainless Steel 316L (1.4404)
	The outer cylinder is in contact with the heating medium
All versions	
Sensor electronics housing	Stainless Steel 316L (1.4409)
Junction box (remote version)	Die cast Aluminium (polyurethane coating)
	Optional Stainless Steel 316L (1.4401)

Process connections

Flange	
DIN	DN10...100 / PN40...100
ASME	½...4" / ASME 150...600
JIS	10...100A / 10...20K

Hygienic	
Tri-clover	½...4"
Tri-clamp DIN 32676	DN10...80
Tri-clamp ISO 2852	1½...4"
DIN 11864-2 form A	DN10...80
Male thread DIN 11851	DN10...80
Male thread SMS	1...3"
Male thread IDF / ISS	1...3"
Male thread RJT	1...3"

Electrical connections

Electrical connections	For full details, including power supply, power consumption etc., see technical data for the relevant converter
I/O	For full details of I/O options including data streams and protocols, see technical data for the relevant converter

Approvals and certifications

Mechanical	
Electromagnetic compatibility (EMC) acc. to CE	Namur NE 21/5.95
	2004/108/EC (EMC)
	2006/95/EC (Low Voltage Directive)
European Pressure Equipment Directive	PED 97-23 EC (acc. to AD 2000 Regelwerk)
Factory Mutual / CSA	Class I, Div 1 groups B, C, D
	Class II, Div 1 groups E, F, G
	Class III, Div 1 hazardous areas
	Class I, Div 2 groups B, C, D
	Class II, Div 2 groups F, G
	Class III, Div 2 hazardous areas
ANSI / CSA (Dual Seal)	12.27.901-2003
Hygienic	3A 28-03
	EHEDG
	ASME BPE
Custody transfer	MID 2004/22/EC MI-005
	OIML R117-1
ATEX (acc. 94/9/EC)	
OPTIMASS 7300C non Ex I signal outputs without heating jacket / insulation	
Ex d connection compartment	II 2 G Ex d [ib] IIC T6....T1
	II 2 D Ex tD A21 IP6x T160°C
Ex e connection compartment	II 2 G Ex de [ib] IIC T6....T1
	II 2 D Ex tD A21 IP6x T160°C
OPTIMASS 7300C non Ex I signal outputs with heating jacket / insulation	
Ex d connection compartment	II 2 G Ex d [ib] IIC T6....T1
	II 2 D Ex tD A21 IP6x T170°C
Ex e connection compartment	II 2 G Ex de [ib] IIC T6....T1
	II 2 D Ex tD A21 IP6x T170°C

OPTIMASS 7300C Ex I signal outputs without heating jacket / insulation	
Ex d connection compartment	II 2(1) G Ex d [ia/ib] IIC T6...T1
	II 2(1) D Ex tD [iaD] A21 IP6x T170°C
Ex e connection compartment	II 2(1) G Ex de [ia/ib] IIC T6...T1
	II 2(1) D Ex tD [iaD] A21 IP6x T160°C
OPTIMASS 7300C Ex I signal outputs with heating jacket / insulation	
Ex d connection compartment	II 2(1) G Ex d [ia/ib] IIC T6...T1
	II 2(1) D Ex tD [iaD] A21 IP6x T170°C
Ex e connection compartment	II 2(1) G Ex de [ia/ib] IIC T6...T1
	II 2(1) D Ex tD [iaD] A21 IP6x T170°C
OPTIMASS 7000 / 7010C without heating / insulation	II 2 G Ex ib IIC T6...T1
	II 2 D Ex ibD 21 T150 °C
OPTIMASS 7000 / 7010C with heating / insulation	II 2 G Ex ib IIC T6...T1
	II 2 D Ex ibD 21 T165 °C

ATEX (acc. 94/9/EC) temperature limits

	Ambient temp. T_{amb} °C	Max. medium temp. T_m °C	Temp. class	Max. surface temp. °C
OPTIMASS 7000 / 7010C - no heating jacket / insulation	40	70	T6	T80
		90	T5	T95
		130	T4	T130
		150	T3 – T1	T150
	50	70	T6	T80
		85	T5	T95
		130	T4	T130
		150	T3 – T1	T150
	65	85	T5	T95
		125	T4	T130
		150	T3 – T1	T150
	OPTIMASS 7000 / 7010C - heating jacket / insulation	40	65	T6
80			T5	T95
115			T4	T130
150			T3 – T1	T165
65		80	T5	T95
		115	T4	T130
		150	T3 – T1	T165
		OPTIMASS 7300C - Aluminium converter housing - no heating jacket / insulation	40	55
75	T5			T95
120	T4			T130
150	T3 - T1			T160
50	75		T5	T95
	115		T4	T130
	150		T3 - T1	T160
60	60		T4 - T1	T85
65 ①	65	T4 - T1	T90	

OPTIMASS 7300C- Aluminium converter housing - heating jacket / insulation	40	55	T6	T80
		70	T5	T95
		100	T4	T125
		145	T3 - T1	T170
	50	70	T4	T95
		100	T3 - T1	T125
	60	60	T4 - T1	T85
	65 ①	65	T4 - T1	T90
OPTIMASS 7300C - Stainless Steel converter housing - no heating jacket / insulation	40	55	T6	T80
		75	T5	T95
		120	T4	T130
		150	T3 - T1	T160
	50	75	T5	T95
		115	T4	T130
		135	T3 - T1	T145
	55	55	T4 - T1	T80
OPTIMASS 7300C - Stainless Steel converter housing - heating jacket / insulation	40	55	T6	T80
		70	T5	T95
		100	T4	T125
		145	T3 - T1	T170
	50	70	T5	T95
		75	T4 - T1	T100
	55	55	T4 - T1	T80

① depending on I/O option. Please call for more information.

Maximum end loadings

Size	06	10	15	25	40	50	80
Titanium							
Flanges	19kN	25kN	38kN	60kN	80kN	170kN	230kN
Hygienic (all connections)	1.5kN	2kN	5kN	9kN	12kN	12kN	30kN
Stainless Steel / Hastelloy® / Tantalum							
Flanges	19kN	25kN	38kN	60kN	80kN	80kN	170kN
Hygienic (all connections)	1.5kN	2kN	5kN	9kN	12kN	12kN	18kN

- These (axial) loads have been calculated, based on 316L schedule 40 process pipework, where un-radiographed butt welds have been used in pipe joints.
- The loads shown are the maximum permitted static load. If loads are cycling (between tension and compression) these loads should be reduced. For advice, consult the manufacturer.



CAUTION!

The maximum permitted end loading on size 15 meters fitted with ½" ASME flanges is 19kN

6.3 Measuring accuracy

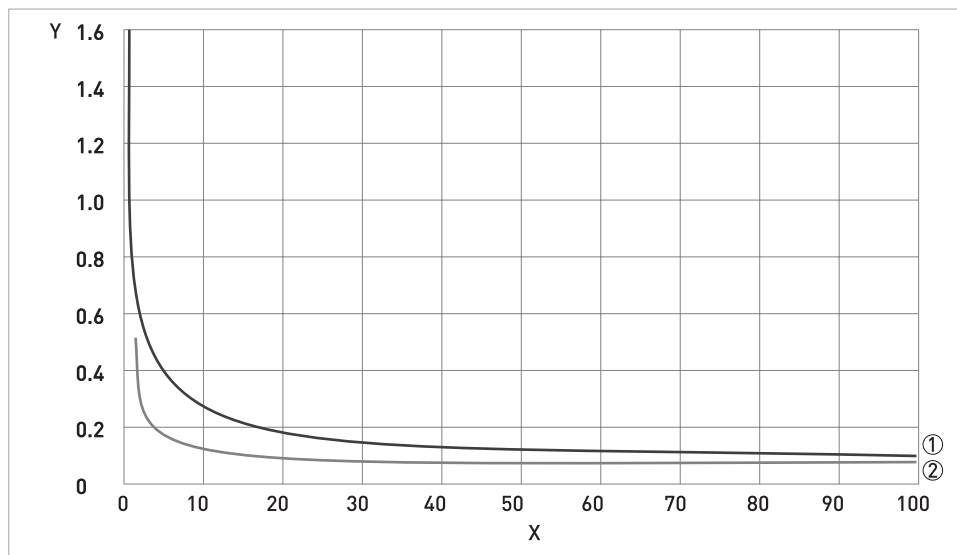

X flow rate [%]
 Y measuring error [%]

- ① Stainless Steel, Hastelloy® and Tantalum
- ② Titanium

Measuring error

The measuring error is obtained from the combined effects of accuracy and zero stability.

Reference conditions

Product	Water
Temperature	+20°C / +68°F
Operating pressure	1 barg / 14.5 psig

6.4 Guidelines for maximum operating pressure

Notes

- Ensure that the meter is used within its operating limits
- All hygienic process connections have a maximum operating rating of 10 barg at 150°C / 145 psig at 302°F

Pressure / temperature de-rating for Titanium Gr 9 meters (all meter sizes, with flanged connections as per EN 1092-1 and JIS B 2220)

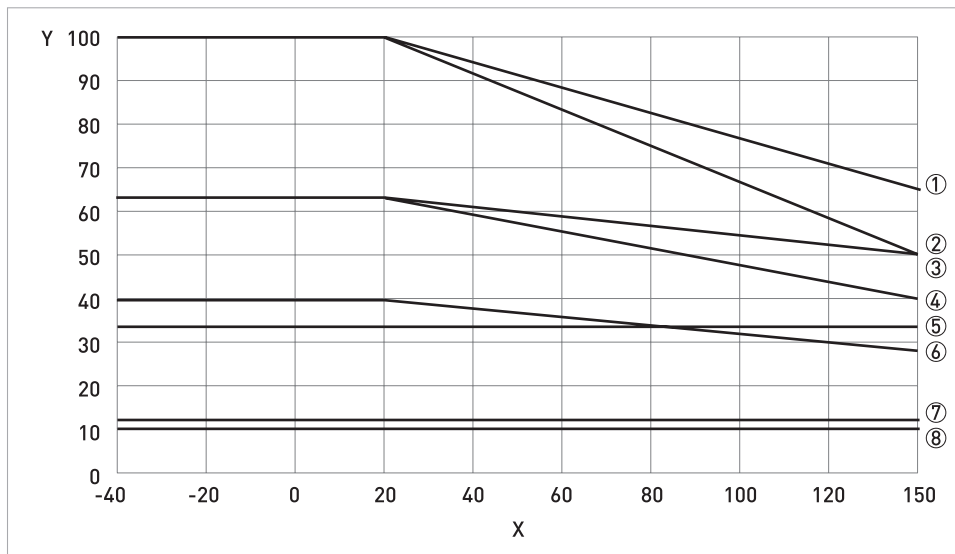

X temperature [°C]

Y pressure [barg]

- ① Standard tube and outer cylinder 316L (100 barg PED option) with PN100 flanges (sizes DN06...25)
- ② Standard tube and outer cylinder 316L (100 barg PED option) with PN100 flanges (sizes DN40...80)
- ③ DIN 2637 PN63 flanges
- ④ Outer cylinder (63 barg PED / CRN option)
- ⑤ JIS 20K flanges
- ⑥ DIN 2635 PN40 flanges
- ⑦ JIS 10K flanges
- ⑧ Hygienic connections

**Pressure / temperature de-rating for Titanium Gr 9 meters
(all meter sizes with flanged connections as per ASME B16.5)**

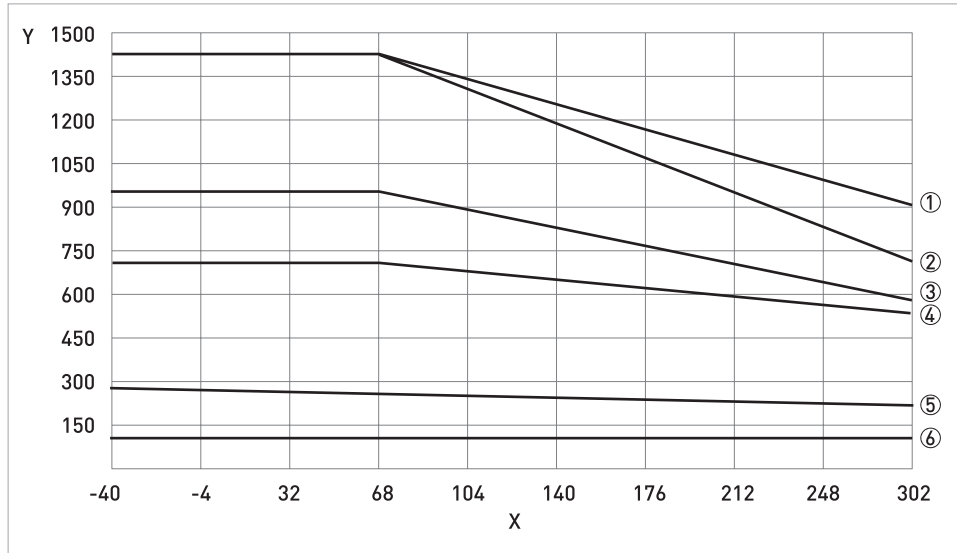

X temperature [°F]

Y pressure [psig]

- ① Standard tube and outer cylinder 316L (100 barg PED option) with ASME 600 lbs flanges (sizes DN06...25)
- ② Standard tube and outer cylinder 316L (100 barg PED option) with ASME 600 lbs flanges (sizes DN40...80)
- ③ Outer cylinder (63 barg PED / CRN option)
- ④ ASME 300 lbs
- ⑤ ASME 150 lbs
- ⑥ Hygienic connections

Pressure / temperature de-rating for Stainless Steel, Hastelloy® C22 and Tantalum meters (all meter sizes with flanged connections as per EN 1092-1 and JIS B 2220)

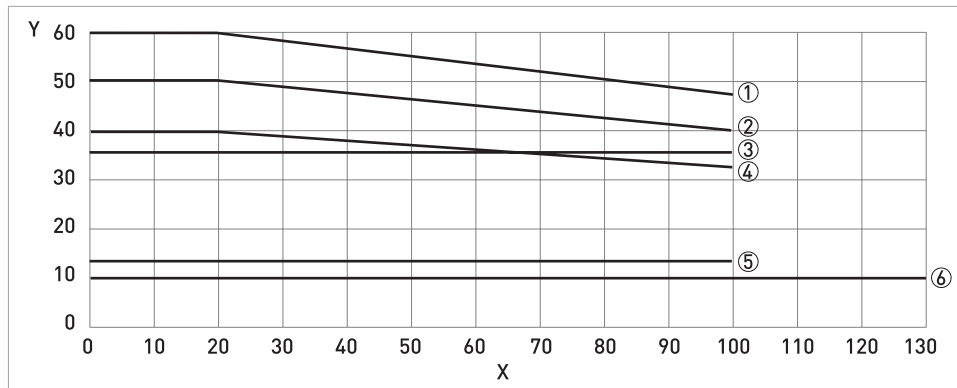

X temperature [°C]

Y pressure [barg]

- ① Outer cylinder de-rating for SS and Hastelloy® meters, all sizes. (63 barg PED / CRN option)
- ② De-rating for SS, Hastelloy® and Tantalum measuring tubes and outer cylinder de-rating for Tantalum meters (all sizes).
- ③ JIS 20K flanges
- ④ DIN 2635 PN40 flanges
- ⑤ JIS 10K flanges
- ⑥ Hygienic connections (extended temperature option, Stainless Steel only)

Pressure / temperature de-rating for Stainless Steel, Hastelloy® C22 and Tantalum meters (all meters with flanged connections as per ASME B16.5)

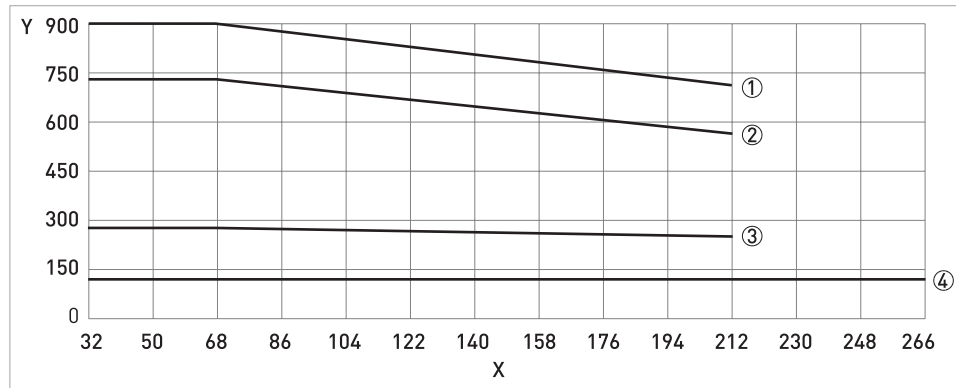

X temperature [°F]

Y pressure [psig]

- ① Outer cylinder de-rating for SS and Hastelloy® meters, all sizes. (63 barg PED / CRN option)
- ② De-rating for SS, Hastelloy® and Tantalum measuring tubes and outer cylinder de-rating for Tantalum meters (all sizes). De-rating for ASME 300 lbs flanges
- ③ De-rating for ASME 150 lbs flanges
- ④ Hygienic connections (extended temperature option, Stainless Steel only)

Flanges

- DIN flange ratings are based on EN 1092-1 2001 table 18, 1% proof stress material group 14E0
- ASME flange ratings are based on ASME B16.5 2003 table 2 material group 2.2
- JIS flange ratings are based on JIS B 2220: 2012 table 11 division 1 material group 022a

Notes

- The maximum operating pressure will be either the flange rating or the measuring tube rating, **WHICHEVER IS THE LOWER!**
- The manufacturer recommends that the seals are replaced at regular intervals. This will maintain the hygienic integrity of the connection.

6.5 Dimensions and weights

6.5.1 Flanged versions

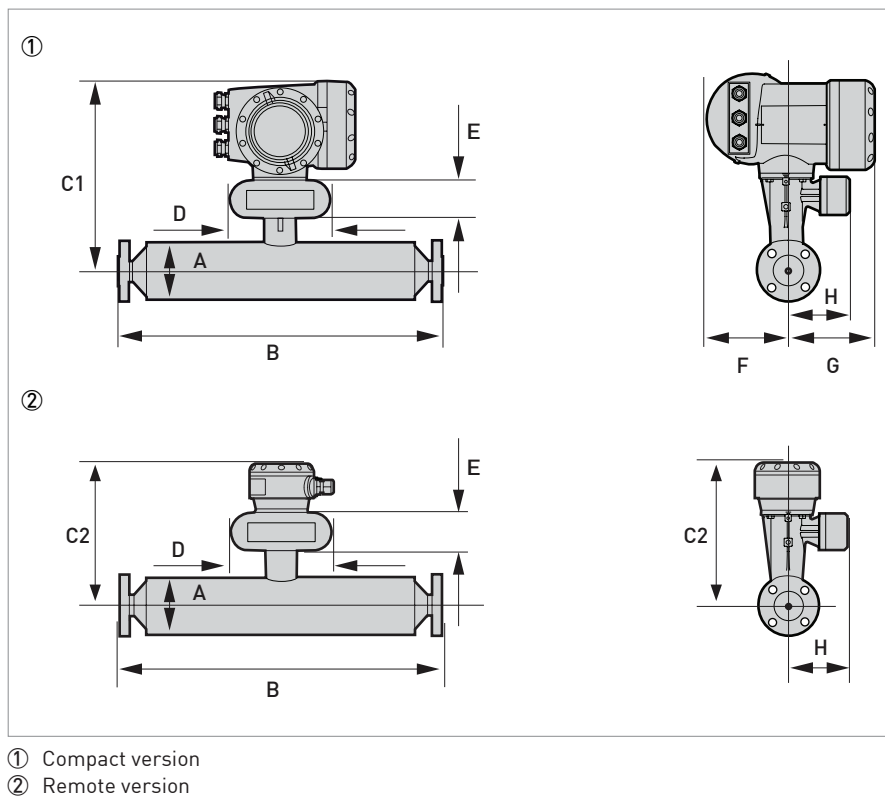

Meter weights for Titanium (T), Stainless Steel (S), Hastelloy®(H) and Tantalum (A)

	Weight [kg]						
	T/S 06	T/S/H/A 10	T/S/H/A 15	T/S/H/A 25	T/S/H/A 40	T/S/H/A 50	T/H 80
Aluminium (compact)	18.5	23	26	37	83	147	265
Stainless Steel (compact)	25.2	29.7	32.7	43.7	89.7	153.7	271.7
Aluminium (remote)	15.7	20.2	23.2	34.2	80.2	144.2	262.2
Stainless Steel (remote)	16.5	21	24	35	81	145	263
Tantalum add	-	1.8	2.7	4.5	9.2	15.1	-

	Weight [lbs]						
	T/S 06	T/S/H/A 10	T/S/H/A 15	T/S/H/A 25	T/S/H/A 40	T/S/H/A 50	T/H 80
Aluminium (compact)	40.7	50.6	57.2	81.4	182.6	323.4	583
Stainless Steel (compact)	55.4	65.3	71.9	96.1	197.3	338.1	597.7
Aluminium (remote)	34.5	44.4	51	75.2	176.4	317.2	576.8
Stainless Steel (remote)	36.3	46.2	52.8	77	178.2	319	578.6
Tantalum add	-	4	5.9	9.9	20.2	33.2	-

Measuring tube in Titanium (T), Stainless Steel (S) or Hastelloy®(H)

	Dimensions [mm]						
	T/S 06	T/S/H 10	T/S/H 15	T/S/H 25	T/S/H 40	T/S/H 50	T/S/H 80
A	102			115	170	220	274
B ①	420 ±2	510 ±2	548 ±2	700 ±2	925 ±2	1101 ±2	1460 ±4
B ②	428 ±2	518 ±2	556 ±2	708 ±2	933 ±2	1109 ±2	1468 ±4
C1 (compact)	311			318	345	370	397
C2 (remote)	231 ±2			237 ±2	265 ±2	290 ±2	317 ±4
D	160						
E	60						
F	123.5						
G	137						
H	98.5						

① all pressure ratings up to 600 lbs and all DIN flanges with standard raised faces.

② ASME flange 600 lbs and all DIN flanges with raised face types: C; D; E and F.

	Dimensions [inches]						
	T/S 06	T/S/H 10	T/S/H 15	T/S/H 25	T/S/H 40	T/S/H 50	T/S/H 80
A	4			4.5	6.7	8.7	10.8
B ①	16.5±0.08	20 ±0.08	21.6 ±0.08	27.5 ±0.08	36.4 ±0.08	43.3 ±0.08	57.5 ±0.16
B ②	16.8 ±0.08	20.4±0.08	21.9 ±0.08	27 ±0.08	36.7±0.08	43.3 ±0.08	57.8 ±0.16
C1 (compact)	12.2			12.5	13.6	14.6	15.6
C2 (remote)	9 ±0.08			9.3 ±0.08	10.4 ±0.08	11.4 ±0.08	12.5 ±0.16
D	6.3						
E	2.4						
F	4.9						
G	5.4						
H	3.9						

① all pressure ratings up to 600 lbs and all DIN flanges with standard raised faces.

② ASME flange 600 lbs and all DIN flanges with raised face types: C; D; E and F.

Measuring tube in Tantalum (A)

	Dimensions [mm]				
	A 10	A 15	A 25	A 40	A 50
A	102	102	115	170	220
B (standard flange)	557 ±2	633 ±2	800 ±2	1075 ±2	1281 ±2
C1 (compact)	311	311	318	345	370
C2 (remote)	231 ±2	231 ±2	237 ±2	265 ±2	290 ±2
D	160				
E	60				
F	123.5				
G	137				
H	98.5				

	Dimensions [inches]				
	A 10	A 15	A 25	A 40	A 50
A	4	4	4.5	6.7	8.7
B (standard flange)	21.9 ±0.08	21.6 ±0.08	27.5 ±0.08	36.4 ±0.08	43.3 ±0.08
C1 (compact)	12.2	12.2	12.5	13.6	14.6
C2 (remote)	9 ±0.08	9 ±0.08	9.3 ±0.08	10.4 ±0.08	11.4 ±0.08
D	6.3				
E	2.4				
F	4.9				
G	5.4				
H	3.9				

6.5.2 Hygienic versions

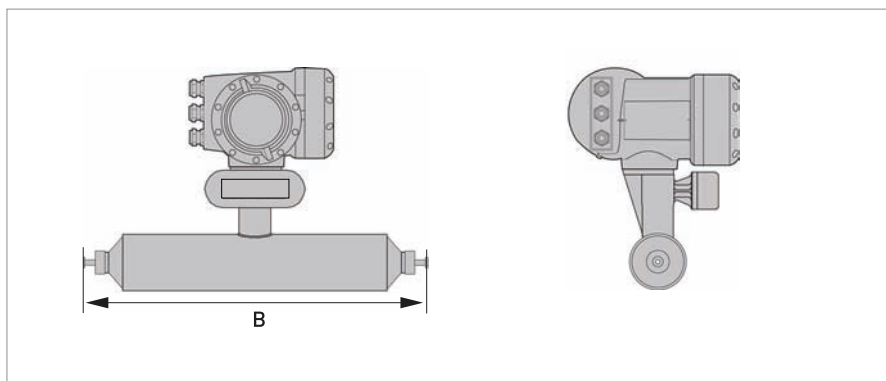

Hygienic connections: all welded versions

	Dimension B [mm]						
	T/S 06	T/S 10	T/S 15	T/S 25	T/S 40	T/S 50	T/S 80
Tri-clover							
½"	480 ±2	558 ±2	-	-	-	-	-
¾"	-	-	596 ±2	-	-	-	-
1½"	-	-	-	816 ±2	-	--	-
2"	-	-	-	-	1043	-	-
3"	-	-	-	-	-	1305 ±2	-
4"	-	-	-	-	-	-	1527 ±2
Tri-clamp DIN 32676							
DN10	484 ±2	564 ±2	-	-	-	-	-
DN15	-	-	602 ±2	-	-	-	-
DN25	-	-	-	761 ±2	-	-	-
DN40	-	-	-	-	986 ±2	-	-
DN50	-	-	-	-	-	1168 ±2	-
DN80	-	-	-	-	-	-	1584 ±2
Tri-clamp ISO 2852							
1½"	-	-	-	816 ±2	-	-	-
2"	-	-	-	-	1043 ±2	-	-
3"	-	-	-	-	-	1305 ±2	-
4"	-	-	-	-	-	-	1527 ±2
DIN 11864-2 form A							
DN10	-	528 ±2	-	-	-	-	-
DN15	-	-	566 ±2	-	-	-	-
DN25	-	-	-	718 ±2	-	-	-
DN40	-	-	-	-	948 ±2	-	-
DN50	-	-	-	-	-	1124 ±2	-
DN80	-	-	-	-	-	-	1538 ±2

	Dimension B [inches]						
	T/S 06	T/S 10	T/S 15	T/S 25	T/S 40	T/S 50	T/S 80
Tri-clover							
1/2"	18.9 ±0.08	22 ±0.08	-	-	-	-	-
3/4"	-	-	23.5 ±0.08	-	-	-	-
1 1/2"	-	-	-	32.1 ±0.08	-	-	-
2"	-	-	-	-	41 ±0.08	-	-
3"	-	-	-	-	-	51.4 ±0.08	-
4"	-	-	-	-	-	-	49.5 ±0.08
Tri-clamp DIN 32676							
DN10	19 ±0.08	22.2 ±0.08	-	-	-	-	-
DN15	-	-	23.7 ±0.08	-	-	-	-
DN25	-	-	-	30 ±0.08	-	-	-
DN40	-	-	-	-	38.8 ±0.08	-	-
DN50	-	-	-	-	-	46 ±0.08	-
DN80	-	-	-	-	-	-	62.4 ±0.08
Tri-clamp ISO 2852							
1 1/2"	-	-	-	32.2 ±0.08	-	-	-
2"	-	-	-	-	41.1 ±0.08	-	-
3"	-	-	-	-	-	51.4 ±0.08	-
4"	-	-	-	-	-	-	60.1 ±0.08
DIN 11864-2 form A							
DN10	-	20.8 ±0.08	-	-	-	-	-
DN15	-	-	22.3 ±0.08	-	-	-	-
DN25	-	-	-	28.3 ±0.08	-	-	-
DN40	-	-	-	-	37.3 ±0.08	-	-
DN50	-	-	-	-	-	44.3 ±0.08	-
DN80	-	-	-	-	-	-	60.5 ±0.08

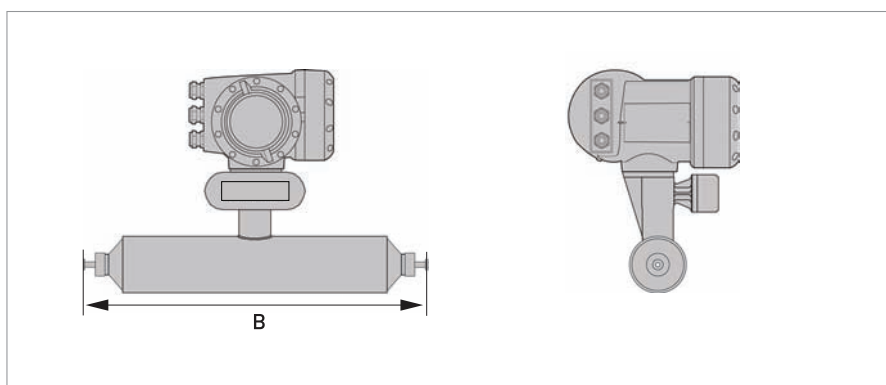

Hygienic connections: adapter versions (Tri-Clover & Tri-clamp)

	Dimension B [mm]				
	T/S 10	T/S 15	T/S 25	T/S 40	T/S 50
Tri-clover					
½"	597 ±2	-	-	-	-
¾"	-	635 ±2	-	-	-
1"	-	665 ±2	-	-	-
1½"	-	-	855 ±2	-	-
2"	-	-	-	1077 ±2	-
3"	-	-	-	-	1355 ±2
Tri-clamp DIN 32676					
DN10	590 ±2	-	-	-	-
DN15	-	628 ±2	-	-	-
DN25	-	-	787 ±2	-	-
DN40	-	-	-	1017 ±2	-
DN50	-	-	-	-	1193 ±2
Tri-clamp ISO 2852					
1"	-	665 ±2	-	-	-
1½"	-	-	855 ±2	-	-
2"	-	-	-	1077 ±2	-
3"	-	-	-	-	1355 ±2

	Dimension B [inches]				
	T/S 10	T/S 15	T/S 25	T/S 40	T/S 50
Tri-clover					
1/2"	23.5 ±0.08	-	-	-	-
3/4"	-	25 ±0.08	-	-	-
1"	-	26.2 ±0.08	-	-	-
1 1/2"	-	-	33.7 ±0.08	-	-
2"	-	-	-	42.4 ±0.08	-
3"	-	-	-	-	53.3 ±0.08
Tri-clamp DIN 32676					
DN10	23.2 ±0.08	-	-	-	-
DN15	-	24.7 ±0.08	-	-	-
DN25	-	-	31 ±0.08	-	-
DN40	-	-	-	40 ±0.08	-
DN50	-	-	-	-	47 ±0.08
Tri-clamp ISO 2852					
1"	-	26.2 ±0.08	-	-	-
1 1/2"	-	-	33.7 ±0.08	-	-
2"	-	-	-	42.4 ±0.08	-
3"	-	-	-	-	53.3 ±0.08

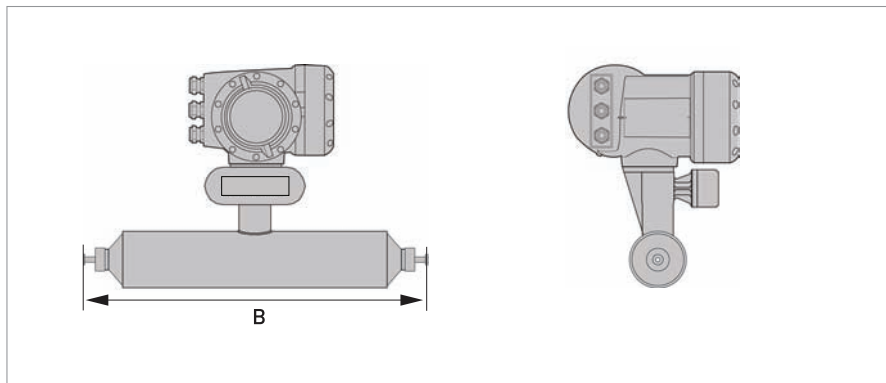

Hygienic connections: adapter versions (male thread)

	Dimension B [mm]					
	T/S 10	T/S 15	T/S 25	T/S 40	T/S 50	T/S 80
Male thread DIN 11851						
DN10	596 ±2	-	-	-	-	-
DN15	-	634 ±2	-	-	-	-
DN25	-	-	802 ±2	-	-	-
DN40	-	-	-	1040 ±2	-	-
DN50	-	-	-	-	1220 ±2	-
DN80	-	-	-	-	-	1658 ±2
Male thread SMS						
1"	-	665 ±2	-	-	-	-
1½"	-	-	852 ±2	-	-	-
2"	-	-	-	1074 ±2	-	-
3"	-	-	-	-	1360 ±2	-
Male thread IDF/ISS						
1"	-	664 ±2	-	-	-	-
1½"	-	-	854 ±2	-	-	-
2"	-	-	-	1076 ±2	-	-
3"	-	-	-	-	1354 ±2	-
Male thread RJT						
1"	-	676 ±2	-	-	-	-
1½"	-	-	866 ±2	-	-	-
2"	-	-	-	1088 ±2	-	-
3"	-	-	-	-	1366 ±2	-

	Dimension B [inches]					
	T/S 10	T/S 15	T/S 25	T/S 40	T/S 50	T/S 80
Male thread DIN 11851						
DN10	23.5 ±0.08	-	-	-	-	-
DN15	-	25 ±0.08	-	-	-	-
DN25	-	-	31.6 ±0.08	-	-	-
DN40	-	-	-	41 ±0.08	-	-
DN50	-	-	-	-	48 ±0.08	-
DN80	-	-	-	-	-	65.3 ±0.08
Male thread SMS						
1"	-	26.2 ±0.08	-	-	-	-
1½"	-	-	33.5 ±0.08	-	-	-
2"	-	-	-	42.3 ±0.08	-	-
3"	-	-	-	-	53.5 ±0.08	-
Male thread IDF/ISS						
1"	-	26.1 ±0.08	-	-	-	-
1½"	-	-	33.6 ±0.08	-	-	-
2"	-	-	-	42.4 ±0.08	-	-
3"	-	-	-	-	53.3 ±0.08	-
Male thread RJT						
1"	-	26.6 ±0.08	-	-	-	-
1½"	-	-	34.1 ±0.08	-	-	-
2"	-	-	-	42.8 ±0.08	-	-
3"	-	-	-	-	53.8 ±0.08	-

6.5.3 Heating jacket version

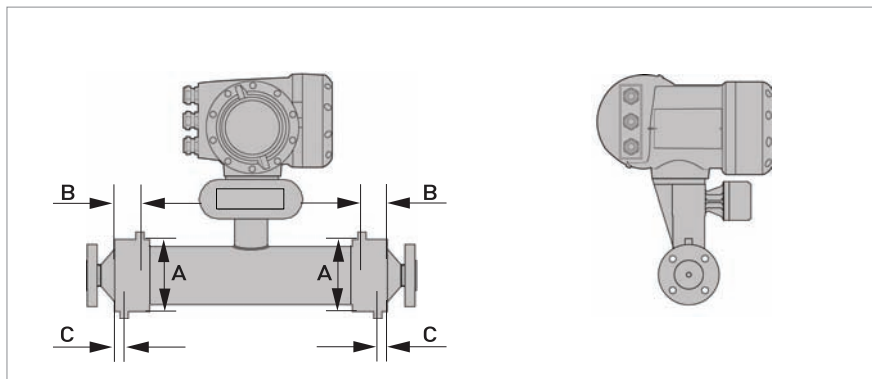

	Dimensions [mm]					
	10	15	25	40	50	80
Heating connection size	12 mm (ERMETO)			25 mm (ERMETO)		
A	115 ±1		142 ±1	206 ±1	254 ±1	305 ±1
Titanium						
B	36 ±1	51 ±1	100 ±1	90 ±1	175 ±1	385 ±1
C	20			26 ±1		
Stainless Steel & Hastelloy®						
B	-	51 ±1	55 ±1	90 ±1	100 ±2	200 ±2
C	-	20		26 ±1		
Tantalum						
B	-	51 ±1	55 ±1	90 ±1	100 ±1	-
C	-	20		26 ±1		-

	Dimensions [inches]					
	10	15	25	40	50	80
Heating connection size	½" (NPTF)			1" (NPTF)		
A	4.5 ±0.04		5.6 ±0.04	8.1 ±0.04	10 ±0.04	12 ±0.04
Titanium						
B	1.4 ±0.04	2 ±0.04	3.9 ±0.04	3.5 ±0.04	6.9 ±0.04	15.2 ±0.04
C	0.8			1.0 ±0.04		
Stainless Steel & Hastelloy®						
B	-	2 ±0.04	2.2 ±0.04	3.5 ±0.04	3.9 ±0.08	7.9 ±0.08
C	-	0.8		1.0 ±0.04		
Tantalum						
B	-	2 ±0.04	2.2 ±0.04	3.5 ±0.04	3.9 ±0.04	-
C	-	0.8		1.0 ±0.04		-

6.5.4 Purge port option

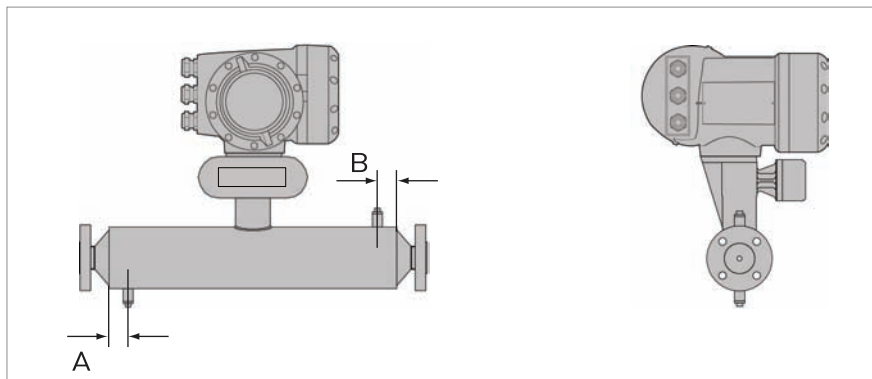

Dimensions [mm]							
	06	10	15	25	40	50	80
Titanium & Stainless Steel							
A	65	30			65		
B	30				65		
Hastelloy®							
A	-	30			65		
B	-	30			65		
Tantalum							
A	-	-	30	65		-	
B	-	-	30	65		-	

Dimensions [inches]							
	06	10	15	25	40	50	80
Titanium & Stainless Steel							
A	2.6	1.2			2.6		
B	1.2				2.6		
Hastelloy®							
A	-	1.2			2.6		
B	-	1.2			2.6		
Tantalum							
A	-	-	1.2	2.6		-	
B	-	-	1.2	2.6		-	

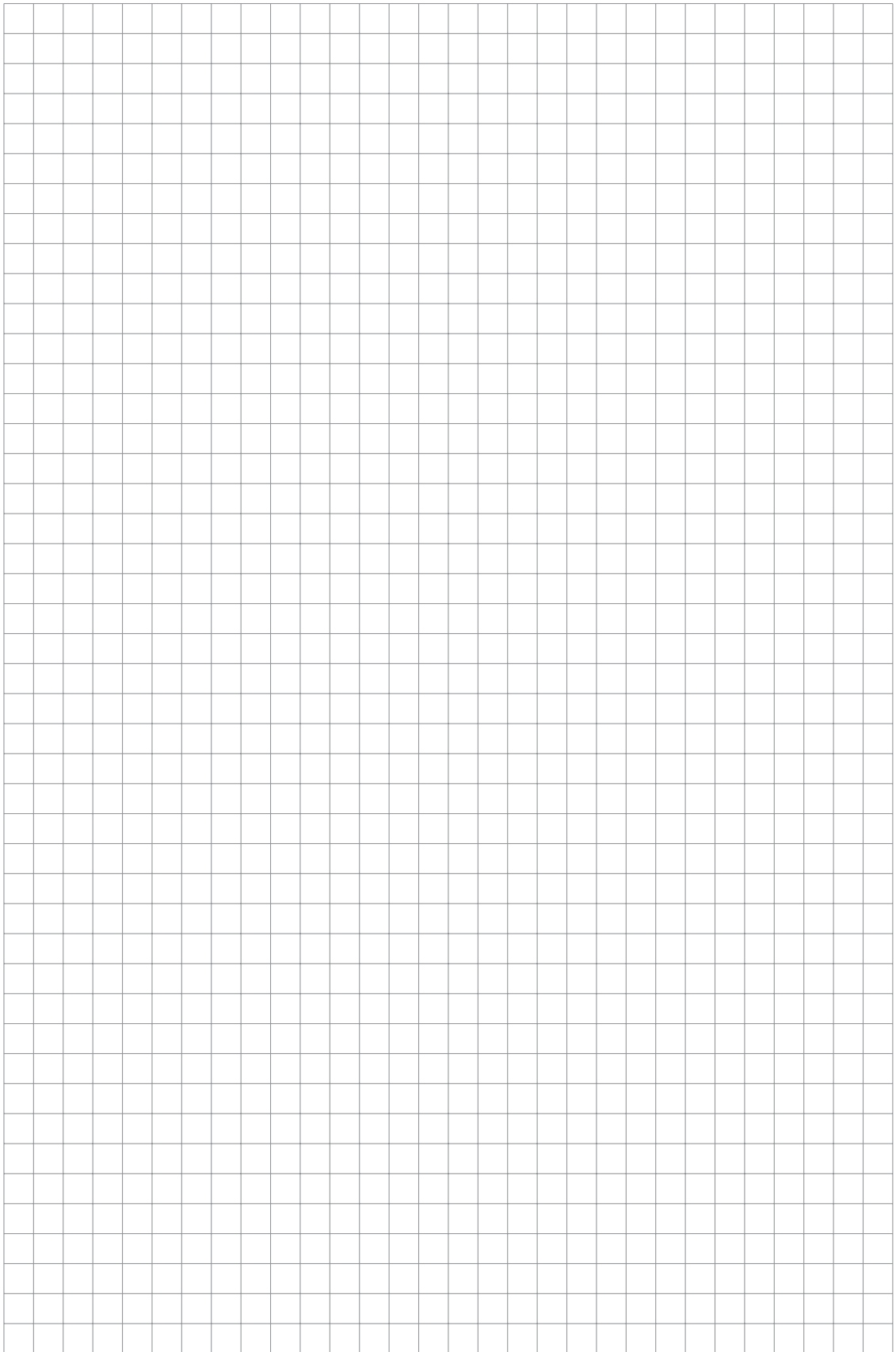

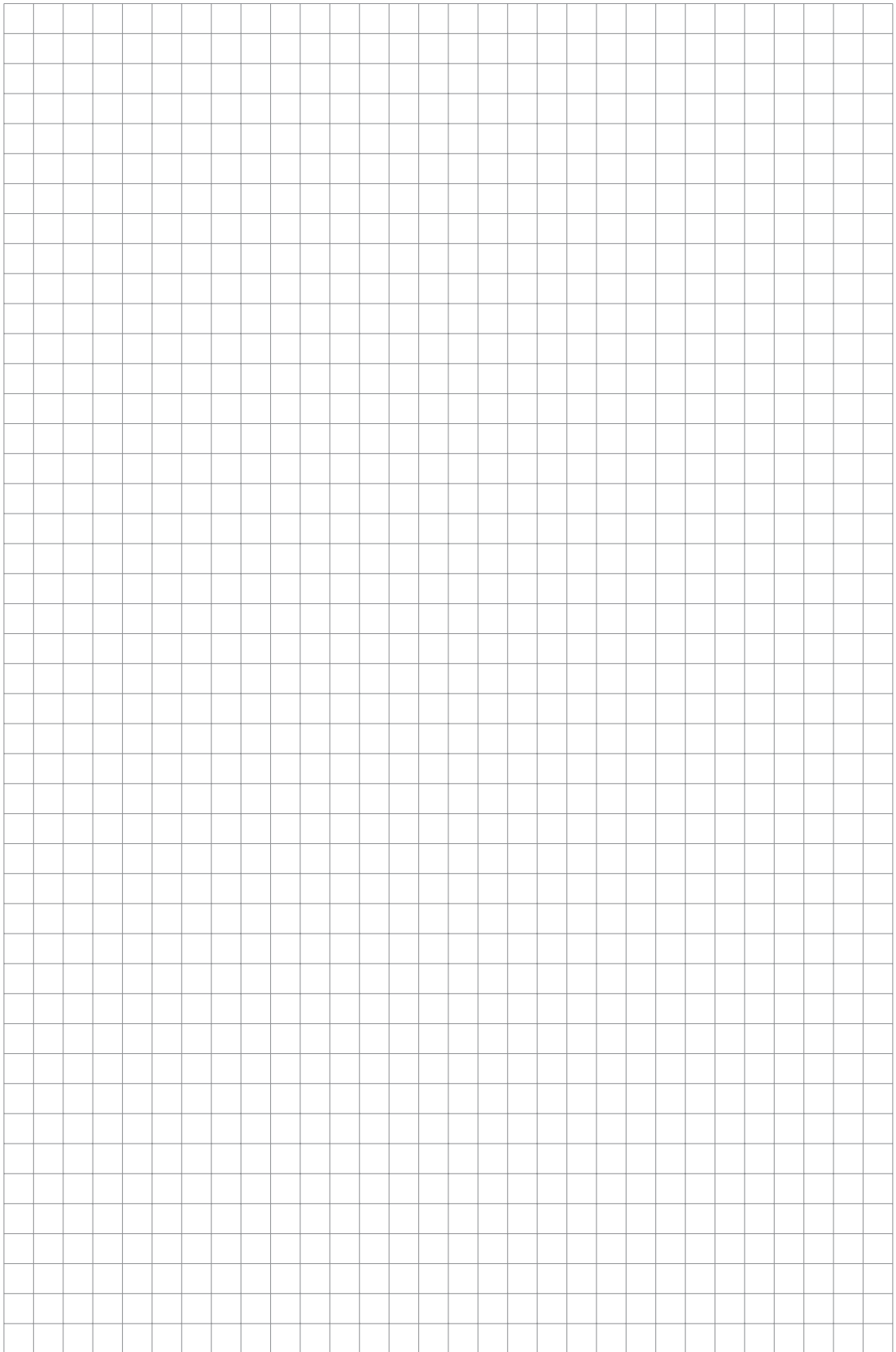



KROHNE – Process instrumentation and measurement solutions

- Flow
- Level
- Temperature
- Pressure
- Process Analysis
- Services

Head Office KROHNE Messtechnik GmbH
Ludwig-Krohne-Str. 5
47058 Duisburg (Germany)
Tel.: +49 203 301 0
Fax: +49 203 301 10389
info@krohne.com

The current list of all KROHNE contacts and addresses can be found at:
www.krohne.com

KROHNE