

DewPro[®] MMR101

*High-Temperature Moisture Transmitter
with Two Current Loops*

User's Manual



DewPro[®] MMR101

High-Temperature Moisture Transmitter

User's Manual

BH067C11 EN C

May 2023

panametrics.com

Copyright 2023 Baker Hughes company.

This material contains one or more registered trademarks of Baker Hughes Company and its subsidiaries in one or more countries. All third-party product and company names are trademarks of their respective holders.

[no content intended for this page]

Chapter 1. General Information

1.1 Introduction1
 1.2 Unpacking1
 1.3 Safety Notes1
 1.4 Order Code2
 1.5 Instrument Components3
 1.6 Mode of Operation3

Chapter 2. Installing the DewPro MMR101

2.1 Introduction5
 2.2 Manually Setting the Measurement Units5
 2.3 Choosing a Mounting Location7
 2.4 Mounting the Unit8
 2.4.1 Using a Compression Fitting8
 2.4.2 Using a Bracket9
 2.5 Making Electrical Connections9
 2.5.1 Preparation10
 2.5.2 System Configuration with One or Two 24 VDC Power Supplies11
 2.5.3 System Configuration with One 24 VDC Power Supply and Loop Powered Display12
 2.5.4 System Configuration with External Power Supply and Display13

Chapter 3. Operating the MMR101

3.1 Introduction15
 3.2 Powering Up15
 3.3 Displaying Measurements15
 3.4 Description of Matrix Options17
 3.4.1 System Administration Options17
 3.4.2 Moisture Measurement Options18
 3.4.3 Temperature Measurement Options20
 3.5 Error Codes and Messages21
 3.6 Measurement Accuracy21

Chapter 4. Troubleshooting

Chapter 5. Maintenance

5.1 Cleaning25
 5.2 Calibration25
 5.3 Repairs25

Chapter 6. Specifications

[no content intended for this page]

Chapter 1. General Information

1.1 Introduction

The DewPro MMRI01 is a moisture and temperature transmitter featuring two patented isolated 4 to 20-mA current loops. The measuring range lies between 0 to 100% relative humidity at temperatures of up to 150°C (300°F). This transmitter has been designed for use in low and high-temperature ranges, such as chemical processes, textile production and the glass, cement and steel industries. This instrument can be used in pressurized and not pressurized systems with pressures of up to 10 bar.

1.2 Unpacking

Inspect for any damaged packaging and contents. The post office or freight carrier must be informed of any damage. Damaged merchandise must be retained until the matter has been settled.

Check that the delivery is complete and agrees with the shipping documents of your order (refer to nameplate for type and variant).

The delivery comprises:

- DewPro[®] MMRI01
- User's Manual
- Depending on your order: process connection and display
- Calibration certificate

If you have any questions, consult your supplier or the Panametrics sales agency in your area (see back cover of these operating instructions for addresses).

1.3 Safety Notes

- You should strictly adhere to the notes and warnings in this manual.
- Operating this instrument in any way other than as described in this manual may compromise the safety and function of the measuring instrument.
- Troubleshooting should only be performed by authorized and trained personnel.
- To prevent accidental startup, remove the unit from service if you cannot remedy faults.
- Damaged equipment should be clearly identified as such to prevent danger.
- Repair work must be performed by authorized Panametrics Service Personnel.

1.4 Order Code

You can identify the various options for your unit by order code on the nameplate of the instrument.



Figure 1: Nameplate

Moisture Sensor DewPro MMR101

Certification/Approvals

- R Standard (not certified)
- A FM IS Class I, II, III; Division 1, Groups A-G, T4
- B FM XP-IS Class I, Division 1, Groups A-D, T5
- C FM NI Class, Division 2, Groups A-D, T4;
DIP Class II, III; Division 1, Groups E-G, T4
- F ATEX II 3G EEx nA IIC T4
- S Other

Process Connection

- 3 1/2" NPT-M compression fitting
- 8 G 1/2" compression fitting
- 6 No mounting hardware
- 2 3/4" NPT-M compression fitting
- 4 3/4" x 16 "O" ring seal compression fitting (UNF thread)
- S Other

Moisture output units

- R % Relative Humidity
- C °C Dew Point
- F °F Dew Point
- D g/m³

X	g/kg
V	% by volume
W	°C Wet bulb Temperature
T	°F Wet bulb Temperature
S	Special Version
Display	
1	With Display/User Interface
2	w/o Display, current at error: 22 mA
3	w/o Display, current at error: hold
4	w/o Display, current at error: 3,6 mA
S	Special Version
Probe Length	
A	16" (406 mm) long
B	9" (229 mm) long
S	Special Version

MMR101R	R	3	C	2	B	(example of order code)
---------	---	---	---	---	---	-------------------------

1.5 Instrument Components

The DewPro MMR101 consists of the following components:

- electronics module in industrial IP 67, type 4X enclosure
- 1/2" stainless steel sensor tube
- Compression fitting, G 1/2 or 1/2" NPT thread
- Sensor:- capacitive polymer sensor for moisture measurement- Pt 1000 for temperature measurement
- Protective filter made of sintered stainless steel with a porosity of 40 pm
- Conduit adapter M20 to 1/2 NPT-M

1.6 Mode of Operation

The DewPro MMR101 measures the relative humidity and the temperature of the process. The sensor tube is designed for direct measurement in the process (in-line measurement). The relative humidity is measured using the capacitive measuring principle. The moisture sensor consists of a capacitor with two electrodes. The dielectric constant of an organic dielectric located between the electrodes changes with relative humidity. The capacitance determined is converted to a frequency by the microprocessor. This moisture signal is compared to a calibration table permanently stored in the instrument. The relative humidity in the process is determined based on this signal. A Pt 1000 sensor is used to measure the process temperature. The process temperature is available to the user via a second 4 to 20 mA output. It is also used for moisture measurement temperature compensation. All the moisture units provided by the instrument are determined from relative humidity and temperature.

[no content intended for this page]

Chapter 2. Installing the DewPro MMR101

2.1 Introduction

Installing the DewPro MMR101 consists of finding a suitable installation location, mounting the unit and then making the necessary wiring connections. However, if your unit does not have a display, you should make sure the moisture units have been configured.

Use the following sections to properly install you unit:

- Selecting the Measurement Units, below
- Choosing a Mounting Location on page 7
- Mounting the Unit on page 8
- Making Electrical Connections on page 9

2.2 Manually Setting the Measurement Units

If your MMR101 is not equipped with a display, your unit will already be configured for the measurement units you specified at the time of ordering. Use the steps below to select different units or verify the units is setup as specified.

Note: *The sensor measures relative humidity and temperature. Other moisture units are derived from these live measurements. The temperature loop is 0 to 150°C (32 to 300°F) and is not selectable. See Measurement Accuracy on page 21 for more details on accuracy.*

Use the steps below to reset the desired measurement units.



CAUTION! If your instrument is connected to power, disconnect it before performing the following procedure.

1. If your unit is already installed, disconnect it from the power supply.
2. Remove the housing cover opposite to the terminal side.

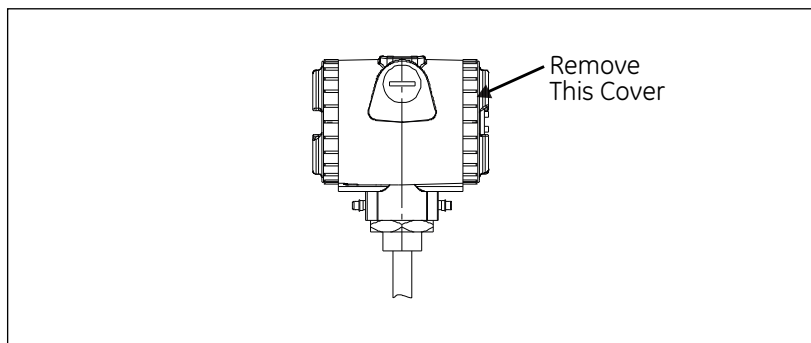

3. Locate the four DIP switches on the printed circuit board.

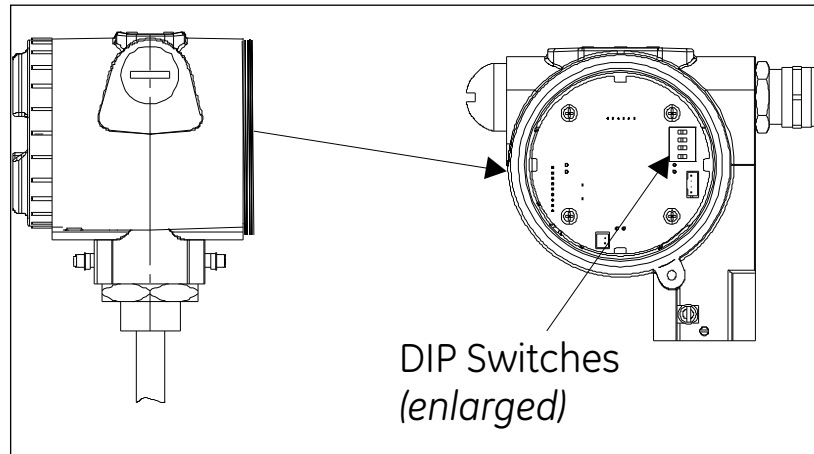

4. Use a pointed object (e.g. a screwdriver) and set switches 1-3 according to the desired output unit (see Table 1 below). Switch No. 4 has no effect.

Table 1: DIP Switch Positions for Unit Selection

Unit	Switch No.			
	1	2	3	4
Relative Humidity %	On	On	On	-
Dew Point °C	Off	On	On	-
Dew Point °F	On	Off	On	-
Absolute humidity g/m ³	Off	Off	On	-
Mixing ratio g/kg	On	On	Off	-
Volume %	Off	On	Off	-
Wet bulb temperature °C	On	Off	Off	-
Wet bulb temperature °F	Off	Off	Off	-

2.3 Choosing a Mounting Location

Choose a mounting location that allows enough clearance for installation and convenient access during normal operation. Refer to Figure 2, below.

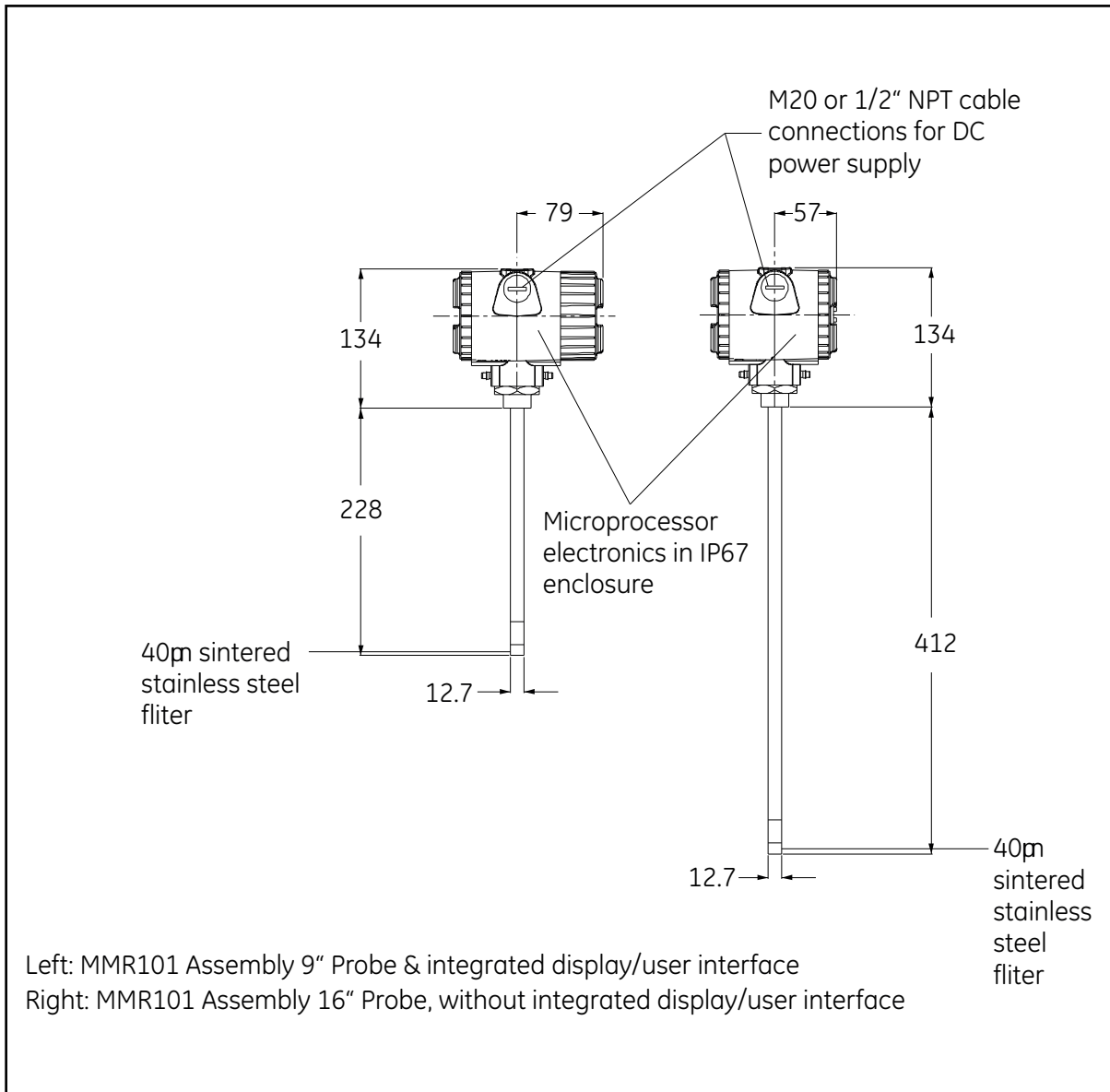

Figure 2: Dimension Drawing

2.4 Mounting the Unit



CAUTION! Only trained personnel should install and operate this unit. Be sure to follow all applicable national electrical codes and safety codes when installing this unit, especially for units installed in hazardous (classified) locations (IS or XP)

You can mount the MMR101 using a:

- Compression Fitting – when installing into a pipe or container.
- Bracket – when measuring trace humidity in ambient air.

Use the appropriate section that follows to select a mounting location and properly install and mount the MMR101.

2.4.1 Using a Compression Fitting



CAUTION! If you are installing the DewPro into a pressurized system (up to 10 bar), depressurize the system before installing or removing the sensor. Pressurized systems require a stainless steel compression fitting.

1. If you are installing the DewPro into a pressurized system, mount it after the shut-off valve and then depressurize the pipe/container.
2. The MMR101 is supplied with a stainless steel compression fitting with a stainless steel ferrule. If you are supplying a fitting, it should be a stainless steel compression fitting with the following:
 - For insertion into pressurized systems, the fitting should have a 1.471 stainless steel ferrule.
 - For un-pressurized systems, the fitting only needs a nylon ferrule; however, a stainless steel ferrule can be used.
3. Adjust the compression fitting to obtain a minimum sensor immersion depth of 3 in. (75 mm).
4. Insert the sensor into the pipe/container into the mating connector. Ideally, the sensor tip should be positioned in the center of the pipe.



CAUTION! When inserting the sensor into the pipe/container, make sure it does not touch the inside wall of the pipe/container.

5. Hand-tighten the nut.
6. Using a wrench, tighten the nut $1\frac{1}{4}$ turns. When tightened properly, the fitting can withstand the specified maximum pressure.

2.4.2 Using a Bracket

When measuring ambient air, the MMRI01 can be mounted directly on a wall, panel or pipe using an optional mounting kit. Mounting kits can be ordered from the factory. Use Figure 3, below to properly install your unit in the desired configuration.

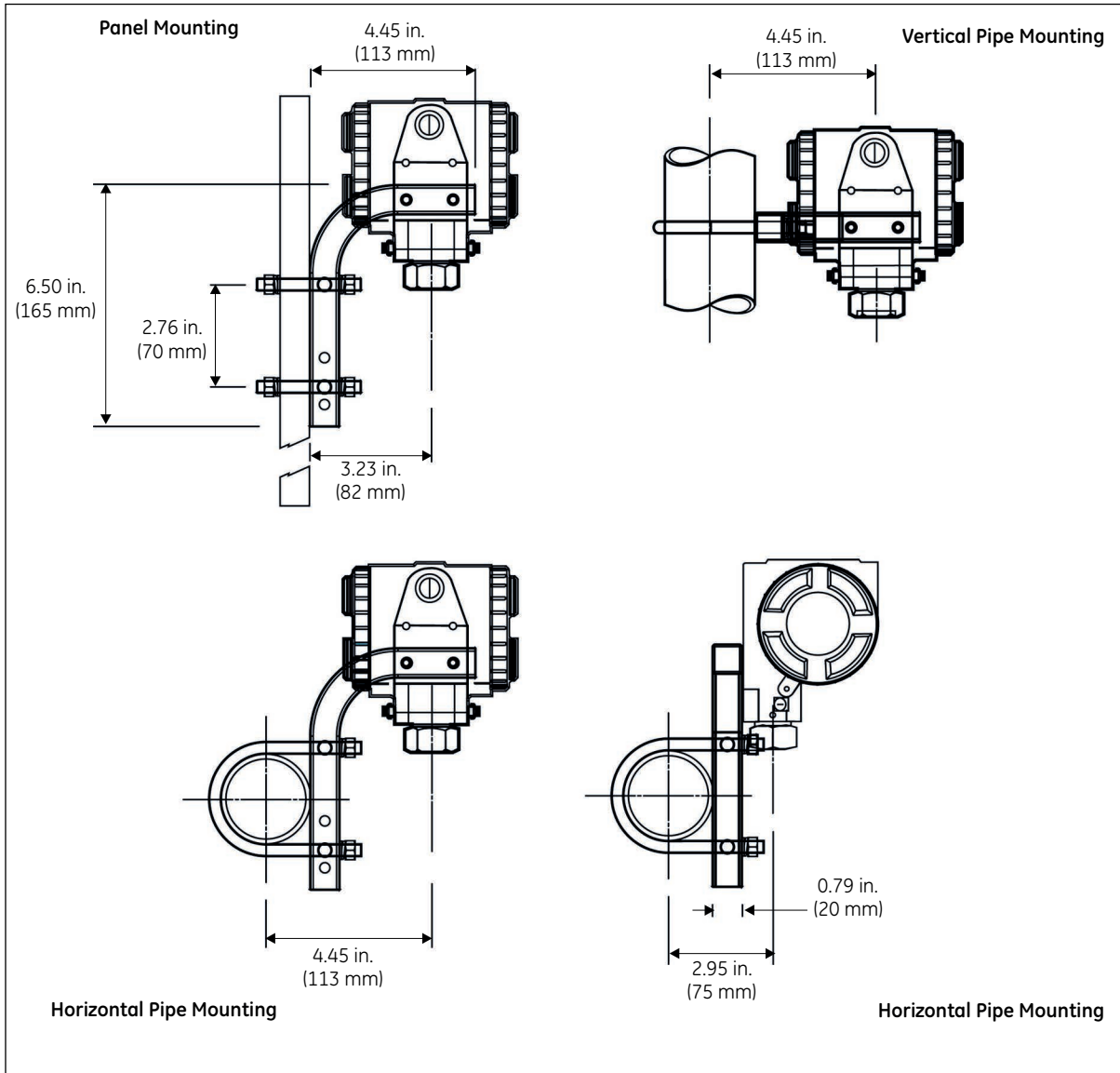

Figure 3: Mounting Kit Configurations

2.5 Making Electrical Connections

The DewPro MMRI01 is a loop-powered moisture and temperature transmitter for two- or four-wire connection being supplied via the signal line (moisture signal). The first circuit transmits the moisture unit selected, the second the process temperature. The DewPro can be optionally supplied from a common or two separate power sources (12 ... 28 V DC). Additional power supply connections are not required.

2.5.1 Preparation

Use the steps below to make electrical connections to the instrument.



CAUTION! Make sure that the voltage between the + and - terminals lies between 12 and 28 V DC.

1. Unscrew the lateral connection cover and remove from the housing.
2. Loosen the lateral cable gland.

Note: If you are using a cable conduit, remove the cable gland and replace with the corresponding M20 1/2" NPT adapter.

3. Feed the cable through the cable opening. Use a shielded 4-wire cable with an outside diameter of 5 mm or greater.
4. Make connection to the terminal block as shown in Figure 4 on the next page. Connect the cable as follows:

Table 2: Cable Connections

Position	Signal
1	Temperature +
2	Temperature -
3	Moisture +
4	Moisture -
5	External Earth Ground
6	Internal Earth Ground

Note: The moisture signal output must always be connected; connecting the temperature signal output is optional. If the signal output for temperature is not needed, the corresponding terminals should not be used.

5. In order to meet EMI/RFI immunity, a 2- or 4-wire shielded cable with a common foil shield layer is being used to power the MMR101. Removing the insulation by 3" allows the user to pull back the foil, clamping it in between the metal cable gland. The ground wire must be connected to the internal grounding screw. This way the MMR101 meets EMC requirements according to IEC 61326, Criterion A (see details under Chapter 6, Specifications.).

6. Tighten the cable gland to assure protection type IP 67 and to provide strain relief for the cable.

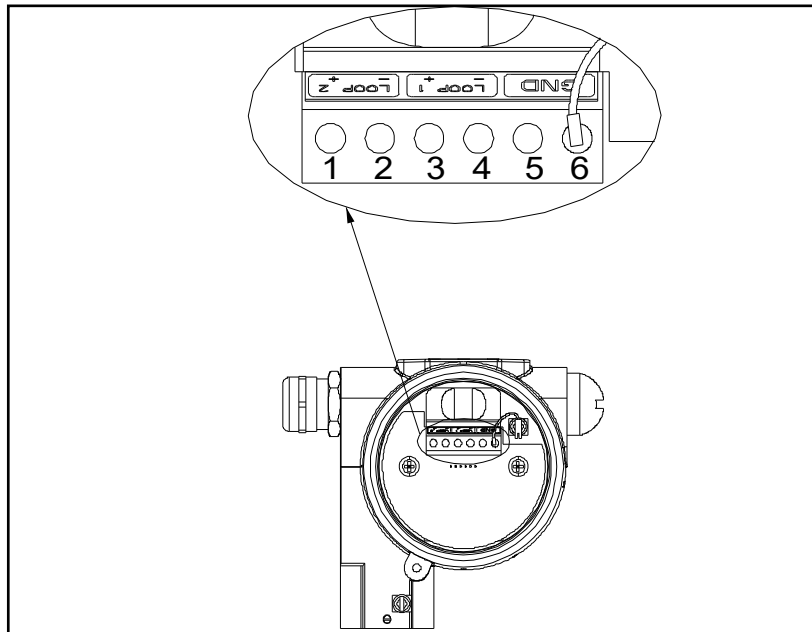

Figure 4: Terminal Block Connections

The DewPro provides various options for making electrical connections. Use the appropriate section that follows to make electrical connections.

2.5.2 System Configuration with One or Two 24 VDC Power Supplies

Use the figure below to make moisture and temperature connections using one or two 24 VDC power supplies.

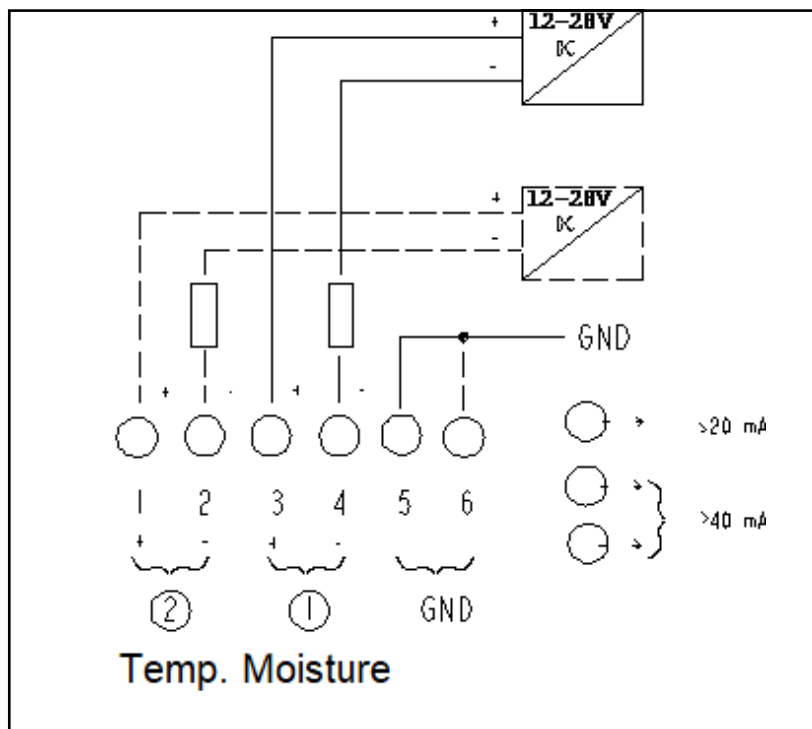

Figure 5: Connection with One or Two 24 VDC Power Supply

Connection 1 above shows a two wire line with power supply and moisture signal output (must always be connected).

Connection 2 shows a galvanically separated signal output for process temperature that can be connected to the same or separate power source.

2.5.3 System Configuration with One 24 VDC Power Supply and Loop Powered Display

When making electrical connection for power and the display you should adhere to the following guidelines:

- The voltage between the + and - terminals must not drop below 12 V DC.
- Every component connected to the loop causes a voltage drop. To determine the supply voltage required, add up the voltage drops of the components connected to the loop and add 12 V. This sum is the required minimum voltage. A safety margin of 20% should be added into the calculated.
- For precision measurement, make sure that both loops are connected to the power supply at the power supply, **do not** use a jumper at the transmitter terminals.
- Adapt the external display to the following measuring ranges based on the 4 to 20 mA current range:
 - 0 to 100% relative humidity
 - -40 to 100°C dew point (*up to 150°C for pressurized systems*)
 - -40 to 212°F dew point (*up to 300°F for pressurized systems*)
 - 0 to 1000 g/m³ absolute humidity
 - 0 to 1000 g/kg mixing ratio
 - 0 to 100% by volume
 - -40 to 212°F wet bulb temperature

Use the Figure 6, below to make moisture and temperature connections using one or two 24 VDC power supplies.

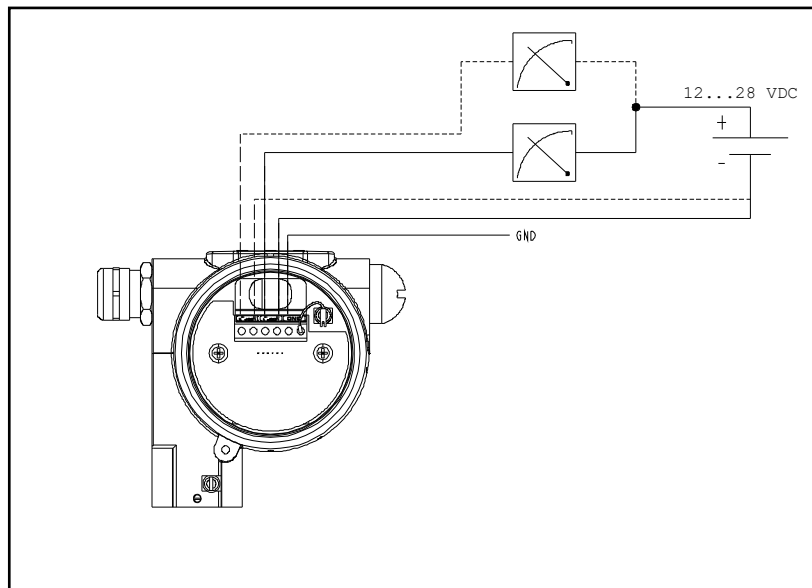

Figure 6: Connection with One 24 VDC Power Supply

2.5.4 System Configuration with External Power Supply and Display

Use Figure 7, below to make electrical connections for the external power supply and display.

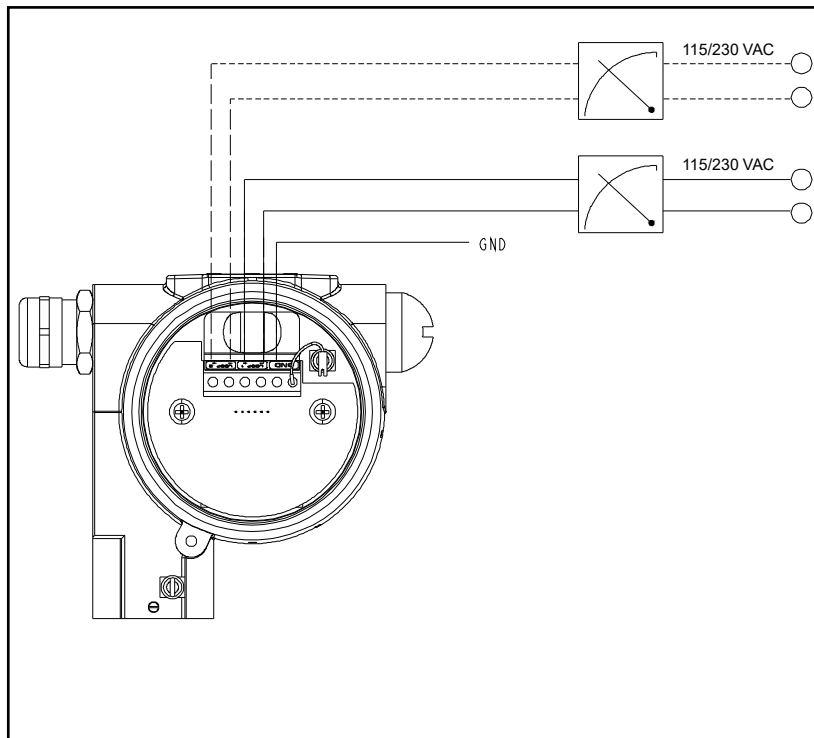

Figure 7: Connection with External Power Supply and Display

[no content intended for this page]

Chapter 3. Operating the MMR101

3.1 Introduction

This section gives a brief description of the MMR101 operation including powering up and displaying measurements. This section includes the following:

- Powering Up
- Displaying Measurements
- Measurement Accuracy

Use these instructions to properly operate the MMR101.



CAUTION! To ensure the safe operation of this unit, you must install and operate the MMR101 as described in this manual. In addition, be sure to follow all applicable safety codes and regulations for installing electrical equipment in your area.

3.2 Powering Up



CAUTION! Before powering up make sure that all equipment in proximity to the unit (e.g. valve, pumps, etc.) is functioning properly.

The MMR101 has a power supply that accepts 12 to 28 VDC (24 VDC nominal). After making electrical connections, including grounding, as described in the previous section, *Installing the MMR101*, connect power. Use the following section to display the desired data.

IMPORTANT: The power line/connection is the main disconnect device.

3.3 Displaying Measurements

If your MMR101 is supplied with a display, you can display the desired measurements using the key located to the left and right of the display as shown in Figure 8, below. Units without the display, must be manually setup as described in *Manually Setting the Measurement Units* on page 5.

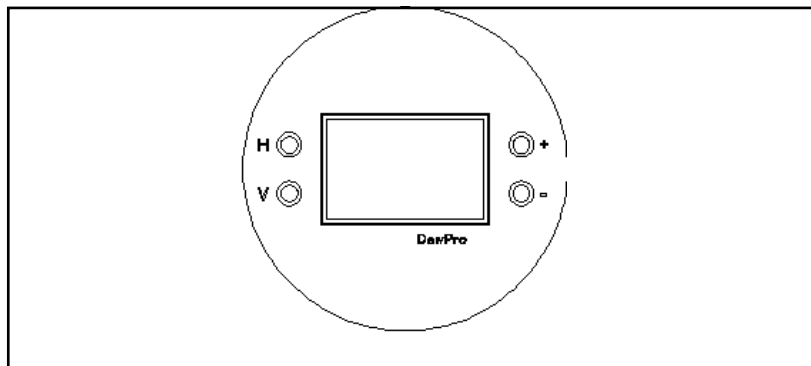

Figure 8: Display and Keys

The available measurements options are arranged in a matrix format. Each option is assigned coordinates on the 10 by 10 matrix, specified with V (vertical), H (horizontal) and a number for each. You select the desired option by entering the matrix position. The matrix, on the next page, shows all the possible options. See below for an example of how to program the unit.

Example:

To set the dew point value to 5°C for 4 mA (V1 H3 on matrix):

1. Press the V key until the display shows V1.
2. Press the H key until the display shows H3.
3. Use the + or - key to change the numeric value to 5.
4. Proceed to any part of the matrix.

See Description of Matrix Options on page 17 for a description of all the possible options.

Note: You can return to position V0 H0 from any field by pressing the V and H keys simultaneously.

MMR101	H0	H1	H2	H3	H4	H5	H6	H7	H8	H9
V0	Display Moisture Value	Select Display Unit	Select Output Unit					Loop #1 at Fault 0 = 110% 1 = -10% 2 = Hold	Display Moisture Freq.	
V1	%RH 4 mA	%RH 20 mA	Dew point °C 4 mA	Dew point °C 20 mA	Dew point °F 4 mA	Dew point °F 20 mA	g/m ³ 4 mA	g/m ³ 20 mA	g/kg 4 mA	g/kg 20 mA
V2	Volume % 4 mA	Volume % 20 mA	°C Wet bulb 4 mA	°C Wet bulb 20 mA	°F Wet bulb 4 mA	°F Wet bulb 20 mA				
V3	Pressure Constant in mmHg								Output #1 D/A Cal 4 mA	Output #1 D/A Cal 20 mA
V4	Display Temp. Value	Select Display Unit 0 = °C 1 = °F				Temp. 4 mA	Temp. 20 mA	Loop #1 at Fault 0 = 110% 1 = -10% 2 = Hold		
V5										
V6										
V7									Output #2 D/A Cal 4 mA	Output #2 D/A Cal 20 mA
V8										Input Locking 50 = unlock
V9	Display present Error Code			Software Version						System Reset 50 = Reset

Matrix Moisture Units: 0=% Relative Humidity 3=g/m³ 6=°C wet bulb temp.
 1=Dew Point °C 4=g/kg 7=°F wet bulb temp.
 2=Dew Point °F 5=% by vol.

3.4 Description of Matrix Options

The options available can be divided up into the following groups:

- system administration
- moisture measurement
- temperature measurement
- error codes/messages

Use the tables below for a description of each option and the corresponding matrix coordinates.

3.4.1 System Administration Options

Table 3: System Administration Options

Location of Matrix	Description of Function
	Unlock/Lock the Matrix
V8 H9	Unlocks and locks the matrix functions. When the matrix is locked, the V and H keys continue to be functional, but the + and - keys are disabled. This prevents unauthorized changes to the user functions. Entering the value, 50 unlocks the matrix. Entering any other value locks the matrix. Default: 0
	System Reset
V9 H9	Resets the instrument settings, similar to switching the instrument off and back on again. No instrument settings are changed. Entering a value of 50 in this position initiates the reset, which is performed after approx. 5 seconds. Normal operation in matrix position VH 00 is resumed after the reset. Default: 0
	Software Version
V9 H3	Displays the software version installed in the instrument.

3.4.2 Moisture Measurement Options

Table 4: Moisture Measurement Options

Location of Matrix	Description of Function
	Measured Values Display
V0 H0	Displays the measured process humidity value. The bar graph shows the output value for the programmed output range as a percentage.
	Selection of the Unit
V0 H1	Unit to be used to display the moisture value in matrix field V0 H0. Options available: 0 = % relative humidity 1 = °C dew point 2 = °F dew point 3 = g/m ³ 4 = g/kg 5 = % of volume 6 = °C wet bulb temperature 7 = °F wet bulb temperature Default = pre selected based on order code
	Sets the moisture range of the 4 to 20 mA output (circuit 1)
V0 H2	Unit to be used for the 4 to 20 mA moisture output. The same selections are available as in position V0 H1. The display and current output units are selected independent of each other. Options available, see V0 H1 Default = pre-selected based on order code
	Loop 1 at fault (circuit 1)
V0 H7	Status of current output 1 according to error detection by the moisture sensor or measuring circuit. Options available: 0 = 110% (22 mA) 1 = -10% (3.6 mA) 2 = hold at previous level Default: on instruments equipped with display: 0 on instruments not equipped with display: selected by order code
	Display of frequency measured (circuit 1)
V0 H8	Displays the current moisture frequency.
	Adjustment of moisture range for 4 to 20 mA output (circuit 1)

Table 4: Moisture Measurement Options

Location of Matrix	Description of Function
V1 H0 V1 H1 V1 H2 V1 H3 V1 H4 V1 H5 V1 H6 V1 H7 V1 H8 V1 H9	% RH = 4 mA, default 0 % RH = 20 mA, default 100 °C dew point = 4 mA, default -40 °C dew point = 20 mA, default 100 °F dew point = 4 mA, default -40 °F dew point = 20 mA, default 212 g/m ³ = 4 mA, default 0 g/m ³ = 20 mA, default 1000 g/kg dry air = 4 mA, default 0 g/kg dry air = 20 mA, default 1000
V2 H0 V2 H1 V2 H2 V2 H3 V2 H4 V2 H5	% by volume = 4 mA, default 0 % by volume = 20 mA, default 100 °C wet bulb temp. = 4 mA, default -40 °C wet bulb temp. = 20 mA, default 150 °F wet bulb temp. = 4 mA, default -40 °F wet bulb temp. = 20 mA, default 300
	Constant pressure adjustment
V3 H0	This function can be used to enter a value for the process pressure (in mm Hg column). This value is only needed to compute the mixing ratio in g/kg. Default: 760
	Adjustment of current output 1
V3 H8 V3 H9	Adjustment of the 4 to 20 mA hardware settings for the moisture output. This output is pre adjusted by the factory and normally does not need readjustment. To check the setting, connect a current measuring instrument in series with circuit 1 (see chapter 2). The output signal in position V3 H8 is automatically switched to the 4 mA setting, and V3 H9 is automatically switched to the 20 mA setting. The + and - keys can be used for fine adjustment. Move on to any other matrix field to return the current value measured.

3.4.3 Temperature Measurement Options

Table 5: Temperature Measurement Options

Location of Matrix	Description of Function
V4 H0	Displays the temperature measured. The bar graph shows the output value for the programmed output range as a percentage.
	Selection of unit
V4 H1	Unit of measure to be used to display the temperature in matrix field V4 H0. Options available for selection: 0 = °C 1 = °F
	Adjustment of temperature range of 4 to 20 mA output (circuit 2)
V4 H5 V4 H6	Unit value of measure to be used for the 4 to 20 mA temperature output. The value range for both positions lies between 0 and 150. The output range is always specified in °C independent of the display unit selected. Default: 0 (V5 H5) 150 (V4 H6)
	Loop 2 at fault
V4 H7	Status of current output 2 when an error has occurred in the temperature measuring circuit. Options available for selection: 0 = 110% (22 mA) 1 = - 10% (3.6 mA) 2 = hold at previous level Default: on instruments equipped with display: 0 on instruments not equipped with display: selected by order code.
	Adjustments of current output 2
V7 H8 V7 H9	Adjustment of 4 to 20 mA hardware settings for the temperature output. This output is pre adjusted by the factory and normally does not need readjustment. To check the setting, connect a current measuring instrument in series with circuit 2. The output signal in position V7 H8 is automatically switched to the 4 mA setting, and V7 H9 is automatically switched to the 20 mA setting. The + and - keys can be used for fine adjustment. Move on to any other matrix field to return the output signal to reflect current measured values. Default: On instruments not equipped with display: based on order code

3.5 Error Codes and Messages

The MMRI01 has a series of error codes and messages that appear on the display to indicate certain conditions.

Note: Fields that display data cannot be modified. Fields that can be modified have a flashing digit.

Table 6: Error Codes and Messages

Location of Matrix	Description of Function	
" - - - - "	If this appears in the matrix field, it indicates that the matrix position is assigned.	
V9 H0	Displays the current error code. If no error code is active, dashes (" - - - ") are displayed in this matrix position. If several errors exist, the error codes are displayed using the following priority:	
	Error Code	Error Status
	401	Moisture sensor error
	201	Relative humidity outside upper measuring range
	202	Relative humidity outside lower measuring range
	203	Temperature outside upper measuring range
	204	Temperature outside lower measuring range
	205	RH loop span too large
	206	RH loop span too small
	207	Temperature loop span too large
	208	Temperature loop span too small

3.6 Measurement Accuracy

The sensor measures relative humidity and temperature. Other moisture units are derived from these live measurements.

The accuracy of the instrument is specified as a percentage of relative humidity. Inaccuracy is a result of the temperature dependence of relative humidity. This dependence is due to physical properties and is independent of the measuring apparatus. The influence of temperature fluctuation should be taken into account for relative humidity, as well as the derived moisture units.

Below Table 7 shows the influence of temperature fluctuations of $\pm 1^\circ\text{C}$ on relative humidity.

Table 7: Change in Relative Humidity as a Function of the Temperature

RH	Temperature				
	10°C	20°C	30°C	40°C	50°C
10%	$\pm 0,7\%$	$\pm 0,6\%$	$\pm 0,5\%$	$\pm 0,5\%$	$\pm 0,5\%$
50%	$\pm 3,5\%$	$\pm 3,2\%$	$\pm 3,0\%$	$\pm 2,6\%$	$\pm 2,3\%$
90%	$\pm 6,3\%$	$\pm 5,7\%$	$\pm 5,4\%$	$\pm 4,6\%$	$\pm 4,1\%$

Note: The temperature loop is 0 to 150°C (32 to 300°F).

[no content intended for this page]

Chapter 4. Troubleshooting

Failure	Possible Cause	Remedy
Current signal outside 4 to 20 mA range	The sensor circuit has measured a value which lies outside the calibration table range. This may be caused by very dry process conditions (current < 4 mA) or by condensation effects on the sensor (current > 20 mA).	Check the display diagram on instruments equipped with the optional display module. If the signal arrows on either side are lit or error code 201 or 202 is displayed in pos. V9 H0, this means that the measuring range has been exceeded. Remove the sensor from the process and expose it to ambient air or another air source with a relative humidity between 10 and 90%. Contact Panametrics if the measured value does not return to the 10 to 90% range.
	The dew point or another operand is outside the permissible range.	All operands are limited by specific output ranges. The signal arrows on the display module only light up when the relative humidity lies outside the calibration range. The computed quantity, e.g. for the dew point, may be outside the operating range for several combinations of temperature and relative humidity Operation outside these ranges does not damage the instrument.
No power	Incorrect instrument connection.	Check the voltage and polarity at the + and - connection terminals. The voltage should be between 12 and 28 VDC. Contact Panametrics if there is no current flow even though the voltage and polarity are correct.
Instrument response too slow	The protective filter is soiled.	Remove the instrument from the process. Unscrew the protective filter and clean it with a solvent (e.g. hexing, cleaner's naphtha). If possible, blow clean air (oil- and dust-free) through the filter to loosen dirt.

Note: The instrument settings and calibration data are retained in the event of a power failure thanks to storage in non-volatile memory.

[no content intended for this page]

Chapter 5. Maintenance

5.1 Cleaning

Particulate substances in the process gas may clog the protective filter. This may impair the function of the sensor.

Remove the filter and clean with a strong (halogen-free) solvent or by flushing with oil- and dust-free, dry air.

In the case of processes with a high concentration of finely distributed particles, additional filtering may be required to prevent clogging of the sintered protective filter.

Make sure that the filter does not contain any solvent residue before screwing it back onto the sensor.

The sensor element must always be handled very carefully. If soiled, it may be briefly swished in a solvent (pure hexing, toluene or acetone).

After cleaning the sensor with solvent, allow sufficient time for it to dry before reinstalling it.

5.2 Calibration

Factory Calibration

Fifty-five calibration values covering the entire measuring range are determined at the factory. NIST-certified reference instruments are used for calibration (NIST = National Institute for Standardization Technology). The calibration certificate supplied with the sensor confirms that the sensor matches the reference values.

Recalibrations

Just like moisture measurement, the recalibration cycle greatly depends on the operating conditions (contamination, aggressive media, etc.) and sensor stress. Under normal process conditions, the sensor check / recalibration should be performed after one to two years.

This cycle may be longer or shorter depending on operating conditions and accuracy requirements.

Field Validation

The user can perform a sensor check in the field. This validation takes place at room temperature (approx. 25°C) using saturated salt solutions. It is intended as a decision aid in determining whether or not recalibration or sensor replacement is required.

This check should be performed using an Panametrics test unit with saturated salt solutions of 11.3 and 75.4% relative humidity that can be ordered from the factory.

5.3 Repairs

Repairs must be carried out directly by the manufacturer or by the Panametrics Service Engineer.

[no content intended for this page]

Chapter 6. Specifications

Parameter	Specification
Sensing Element	Polymer; capacitance
RH Range	0 to 100%
RH Accuracy	± 2% up 65°C (150°F) process temperature
Temperature Sensor	Platinum RTD
Temperature Accuracy	± 1.1°C (± 2°F)
Temperature Resolution	0.05°C (0.09°F)
Operating Temperature Range	Process: 0°C to +150°C (+32°F to +300°F) Electronics: -40°C to +85°C (-40°F to 185°F)
Maximum Operating Pressure	150 psi (10.2 bar)
Electronics	Microcontroller operated, loop-powered
Loop Power Supply	24 VDC nominal, 12 to 28 VDC range
Outputs	Two fully isolated 4 to 20 mA current loops (moisture and temperature) patented (U.S. patent #5,677,476)
Hardware Selectable Units	0% to 100% RH, -40°C to 100°C or -40°F to 212°F dew point (up to 300°F or 150°C under system pressure), 0 to 1000 g/m ³ absolute humidity, and 0 to 1000 g/kg mixing ratio dry air, 0 to 100% by volume, -40°C to 100°C or -40°F to 212°F wet bulb temperature.
Standard Temperature Output	0°C to 150°C (32°F to 300°F) range
Display	Four-digit number display with bar graph and matrix position indication. Four user interface keys for unit selections, output adjustments and ranging.
Protection	Type 4X/IP67
Probe Tube	<i>16-in. (406 mm) Probe:</i> 316 stainless steel, 0.5 in diameter. Adjustable insertion length from 3 in. (76 mm) to 14.25 in. (362 mm) <i>9-in. (228 mm) Probe:</i> 3 in. (76 mm) to 7.25 in. (184 mm).
Typical Mounting Adapter	1/2 in. tube X 1/2 in. NPT-M or G1/2 compression fitting; flanges and other sizes available upon request.
Sensor Guard	40 micron sintered filter, 316 stainless steel cap
Weight	4.4 lbs (2 kg)

Parameter	Specification
EMC	Meets IEC 61326 Performance Criterion A: - Conducted Emission Test as per CISPR 11 Class A, 2004 - Radiated Emission Test as per CISPR 11 Class A, 2004 - Radiated Susceptibility Test as per IEC 61000-4-3, 2002 - Electrostatic Discharge Test as per IEC 61000-4-2, 2001 - Electrical Fast Transient Test as per IEC 61000-4-4, 2004 - High Energy Surge Immunity Test as per IEC 61000-4-5, 2001 - Power Frequency Magnetic Field Test as per IEC 61000-4-8, 2001
Hazardous area approvals (optional)	<ul style="list-style-type: none"> • MMR101-Axxxx: Intrinsically safe, Class I, II & III, Division 1, Groups A, B, C, D, E, F & G, Type 4X, T5 Ta = 60°C, Entity, per drawing FM-IS-DewPro (FM Approvals) • MMR101-Bxxxx: Explosionproof with intrinsically safe sensor, Class I, Division 1, Groups A, B, C & D, Type 4X, T5 Ta = 60°C, per drawing FM-XP-Dewpro (FM Approvals) • MMR101-Cxxxx: Non-incendive, Class I, Division 2, Groups A, B, C & D, Type 4X, T4A Ta = 60°C; Dust-ignitionproof, Class II and III, Division 1, Groups E, F and G, Type 4X, T5 Ta = 60°C (FM Approvals) • MMR101-Fxxxx: Non-Sparking apparatus for ATEX Zone 2, II 3 G Ex nA IIC T4 (ATEX declaration by the manufacturer Panametrics)

Warranty

Each instrument manufactured by Panametrics is warranted to be free from defects in material and workmanship. Liability under this warranty is limited to restoring the instrument to normal operation or replacing the instrument, at the sole discretion of Panametrics. Fuses and batteries are specifically excluded from any liability. This warranty is effective from the date of delivery to the original purchaser. If Panametrics determines that the equipment was defective, the warranty period is:

- one year for general electronic failures of the instrument
- one year for mechanical failures of the sensor

If Panametrics determines that the equipment was damaged by misuse, improper installation, the use of unauthorized replacement parts, or operating conditions outside the guidelines specified by Panametrics, the repairs are not covered under this warranty.

The warranties set forth herein are exclusive and are in lieu of all other warranties whether statutory, express or implied (including warranties of merchantability and fitness for a particular purpose, and warranties arising from course of dealing or usage or trade).

Return Policy

If a Panametrics instrument malfunctions within the warranty period, the following procedure must be completed:

1. Notify Panametrics, giving full details of the problem, and provide the model number and serial number of the instrument. If the nature of the problem indicates the need for factory service, Panametrics will issue a RETURN AUTHORIZATION number (RA), and shipping instructions for the return of the instrument to a service center will be provided.
2. If Panametrics instructs you to send your instrument to a service center, it must be shipped prepaid to the authorized repair station indicated in the shipping instructions.
3. Upon receipt, Panametrics will evaluate the instrument to determine the cause of the malfunction.

Then, one of the following courses of action will then be taken:

- If the damage is covered under the terms of the warranty, the instrument will be repaired at no cost to the owner and returned.
- If Panametrics determines that the damage is not covered under the terms of the warranty, or if the warranty has expired, an estimate for the cost of the repairs at standard rates will be provided. Upon receipt of the owner's approval to proceed, the instrument will be repaired and returned.

[no content intended for this page]

Customer Support Centers

U.S.A.

The Boston Center
1100 Technology Park Drive
Billerica, MA 01821

U.S.A.

Tel: 800 833 9438 (toll-free)
978 437 1000

E-mail: panametricstechsupport@bakerhughes.com

Ireland

Sensing House
Shannon Free Zone East
Shannon, County Clare
Ireland

Tel: +353 61 61470200

E-mail: panametricstechsupport@bakerhughes.com

Copyright 2022 Baker Hughes company.

This material contains one or more registered trademarks of Baker Hughes Company and its subsidiaries in one or more countries. All third-party product and company names are trademarks of their respective holders.

BH067C11 EN C

Baker Hughes 