

9491-PS

Intrinsically Safe Power Supply



Instruction Manual

INM9491



CONTENTS

- 1 FEATURES 1**
- 2 DESCRIPTION 1**
- 3 DIN-RAIL INSTALLATION METHOD. 3**
 - 3.1 Protection of equipment 3**
 - 3.2 DIN rail mounting 3**
 - 3.3 Power bus - Installation and use 5**
 - 3.4 Earth rail and tagging accessories 6**
 - 3.5 Assembly 8**
- 4 BACKPLANE MOUNTING METHOD 10**
 - 4.1 Accessories 10**
 - 4.2 Protection of equipment 10**
 - 4.3 Backplane mounting 10**
 - 4.4 Backplanes - identification and tagging 12**
 - 4.5 Backplanes - earth rails 14**
 - 4.6 Backplanes - power supply connections 14**
 - 4.7 Fitting 9491-PS modules to backplane 14**
- 5 ENVIRONMENTAL 16**
- 6 WASTE REMOVAL INFORMATION 16**
- 7 APPROVALS 16**
- 8 FM CERTIFICATION INFORMATION 16**
- 9 ATEX & IECEx CERTIFICATION INFORMATION 17**



1 FEATURES

- ◆ Isolated power supply
- ◆ Zone 2 and Division 2 mountable
- ◆ DIN-rail or backplane mounting
- ◆ ATEX / IECEx approvals
- ◆ FM (USA & Canada) approved
- ◆ 200mA @10.9V DC - Ex ia IIB Groups C, D output
- ◆ 400mA @11.8V DC - Ex ib IIB output
- ◆ Power over Ethernet option (PoEx)*
- ◆ Multiple outputs achieved by ganging 9491 modules using 24V DC power distribution backplane

**Note – PoEx is a simple adaptation of the IEEE 802.3af Power over Ethernet (PoE) standard to bring the benefits to the 9400 Range of Hazardous Area devices. This allows two spare pairs in the existing Cat5e cable to distribute the power supplied to a 9466 Ethernet Switch (Power Sourcing Equipment – PSE) to each of the devices connected to its five ports (PD – Powered Device). This adaptation is necessary due to restrictions for Hazardous Area use. It is not implied that the device conforms to the 802.3af (PoE) standard.*

2 DESCRIPTION

The 9491-PS Power Supply is the recommended method for supplying the 9460-ET series of intrinsically safe Ethernet modules and is based on an isolating power supply. It takes a 24V DC safe area / Zone 2 / Division 2 supply and produces an intrinsically safe, 12V DC nominal output capable of powering any one of the 94xx Series Ethernet modules mounted in a Zone 1 / Division 1 hazardous area. The 9491-PS may be mounted in a safe area, Zone 2 or Division 2 hazardous area.

The output can be from either the Ex ia IIB Groups C, D or Ex ib IIB output connectors depending upon application. The 'ib' IIB output providing a higher useable output power where the Gas Group and Zone allows. See Figures 2.1 and 2.2 for connection details.

Figure 2.1
Zone 0
Ex ia IIB
application

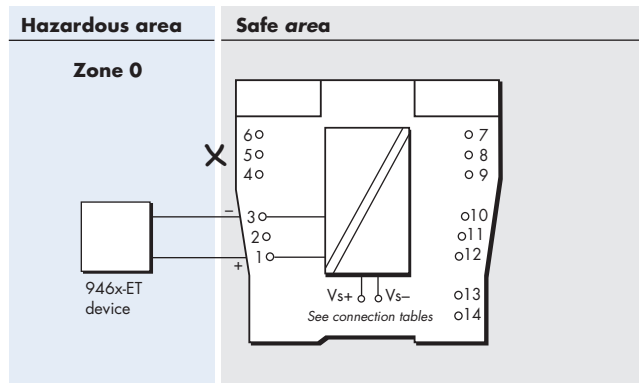

Figure 2.2
Zone 1
Ex ib IIB
application

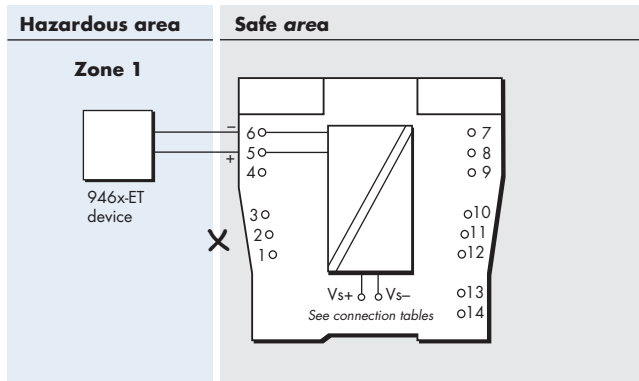

Table 2.1
DIN-rail
mounting
connections

Terminal	Function
1	Ex ia IIB Groups C,D output +ve
2	n.c.
3	Ex ia IIB Groups C,D output -ve
4	n.c.
5	Ex ib IIB Output +ve
6	Ex ib IIB Output -ve
13	Supply -ve (Vs-)
14	Supply +ve (Vs+)

Table 2.2
Backplane
mounting
connections

Terminal	Function
1	Ex ia IIB Groups C,D output +ve
2	n.c.
3	Ex ia IIB Groups C,D output -ve
4	n.c.
5	Ex ib IIB Output +ve
6	Ex ib IIB Output -ve
7, 8 & 9	Supply -ve (Vs-)
10, 11 & 12	Supply +ve (Vs+)

Each 9491-PS can power a single 946x-ET Ethernet module.

It is not permitted to connect to both ia and ib outputs on the same 9491-PS module.

If multiple outputs are required for several Ethernet modules, there is a power distribution backplane available to simplify the 24VDC input connection to the modules, or alternatively a number of them can be DIN-rail mounted with a convenient "Powerbus" input.

The 9491-PS module has LED power indication for both input and output (see Figure 2.3) along with internal current limiting and electronic auto-reset circuit breaker action to protect the module in the event of its output being short circuited or overloaded. This also minimises the power dissipation during the fault to a negligible level, thus improving reliability.

Figure 2.3
9491-PS
top label and
LED indicators

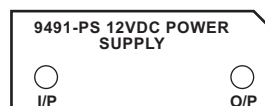

3 DIN-RAIL INSTALLATION METHOD

This section deals with mounting the individual 9491-PS power supplies on DIN rail, for backplane mounting see **Section 4**.



WARNING: If this module is to be connected to intrinsically safe apparatus, it must be installed, operated and maintained only by trained competent personnel and in accordance with all appropriate international, national and local standard codes of practice and site regulation and in accordance with the instructions contained here. See also Sections 7, 8 and 9 for approvals and important conditions of safe use.

3.1 Protection of equipment

When the power supply is mounted in a safe area ensure that the local environment is clean and free of dirt and dust and note the ambient temperature considerations given in Section 5.



WARNING: When mounted in a Zone 2 hazardous area the module *must* be protected by a suitably certified enclosure.

3.2 DIN rail mounting

Mount the 9491-PS power supplies on low-profile (7mm) or high-profile (15mm) type T35 (top-hat) DIN-rail to EN50022, BS5584, DIN46277; this is available from MTL, in 1 metre lengths (THR2 DIN rail). It is recommended that, in normal practice, the DIN rail is earthed to ensure personnel safety in the event of mains being put accidentally on the rail.

See Figure 3.1 for power supply dimensions.

Figure 3.1
9491-PS package
dimensions
& connections

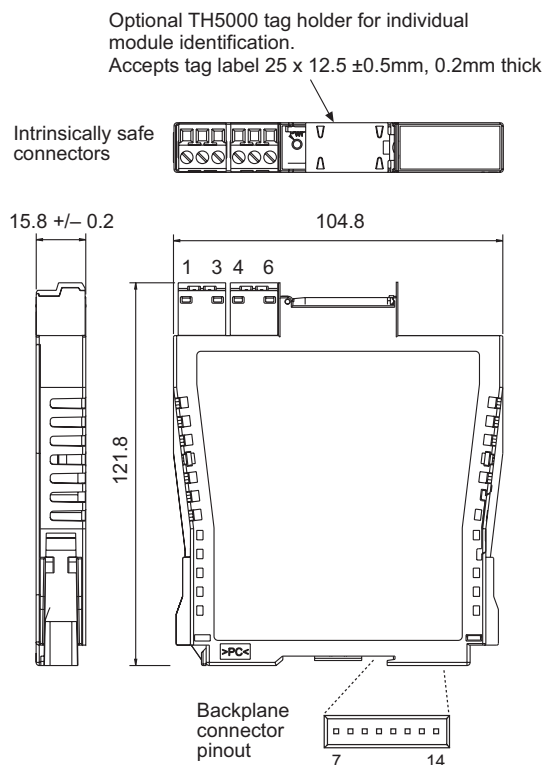

3.2.1 Mounting power supplies on DIN rail

Clip power supplies onto type T35 DIN rail as shown in Figure 3.2, with the blue signal plugs facing towards the hazardous-area wiring. To remove a power supply from the rail, insert a screwdriver blade into the clip as shown and lever the clip gently outwards; pivot the power supply off the rail. Allow a maximum mounting pitch of 16.2mm for each unit.

Figure 3.2
DIN rail mounting
and removal
of module

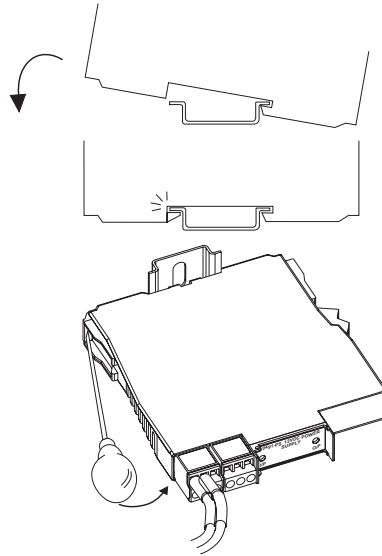

3.2.2 Wiring up power supplies

Depending on the installation, it may be easier to wire up power supplies with power plugs either in place or removed. Either way, allow sufficient free cable to permit plugs to be removed easily for future maintenance and/or replacement purposes.

Power conductors

The removable power plugs are fitted with screw clamp terminals. Note that the conductors should be between 14 and 24 AWG (1.6 and 0.5mm dia) in size. Plugs, located on top of the modules, are mechanically keyed to fit in only one position. The input power plug slots into the socket at terminals 13 and 14 on the safe-area side of each module.

Figure 3.2
Removable
power plugs

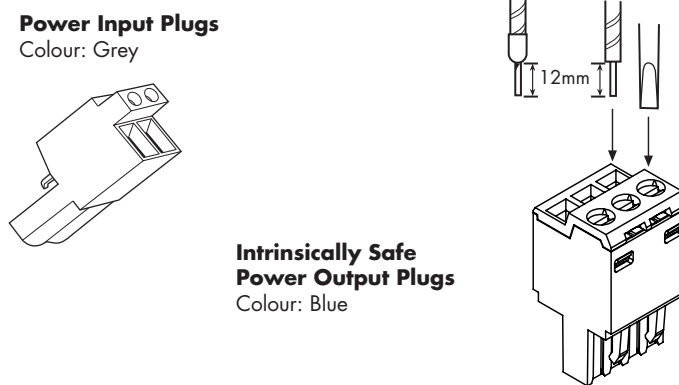

Making connections

- Trim back the insulation of conductors by 12mm.
- Check the terminal assignments shown in section 6 or on the side label of the unit.
- Insert conductors according to the terminal assignments and tighten screws.

If the wires are to be fitted with crimp ferrules, 10–12mm is the recommended length of the metal tube. If longer ones are used, they must be trimmed to 12mm before fitting.

Finishing

Wire up individual power supplies in accordance with wiring schedules. Daisy-chain power supply connections between individual power plugs or use the power bus (see section 4.1).

Segregate hazardous- and safe-area wiring into separate trunking or looms wherever possible to avoid errors and maintain a tidy installation.

3.2.3 Ambient temperature considerations

Ambient temperature limits for unenclosed power supplies are from 0°C to +70°C with units close-packed.

3.3 Power bus - Installation and use

A PB-8T power bus kit enables power supply terminals (13 and 14) of up to 8 installed 9491-PS power supplies to be linked to a standard 24V power supply. The bus consists of a chain of power plugs and different lengths are available to suit various numbers of modules as follows.

3.3.1 Check to make sure the bus length is correct for the number of modules involved.

3.3.2 If the number of modules is less than the maximum number the chain will support, cut off the surplus power plugs at the tail end of the chain - leaving sufficient cable to attach further power plugs if it becomes necessary later.

3.3.3 Insert power plugs into the power terminals on the safe- area side of each module in sequence.

3.3.4 Connect the power supply source to the tail end of the chain (using the insulation displacement connectors [Scotchlocks] provided if required).

Notes:

1. To avoid excessive voltage drop or over-current, DO NOT connect power buses in series.
2. Surplus sections can be used (and, if required) connected together provided the cut ends are safely terminated and/or connected together. Use single ferrules with a crimp tool or insulation displacement connectors (Scotchlocks). Suitable ferrules and connectors are provided with the kits.

Figure 3.3
Power bus
wiring, joining
and terminating

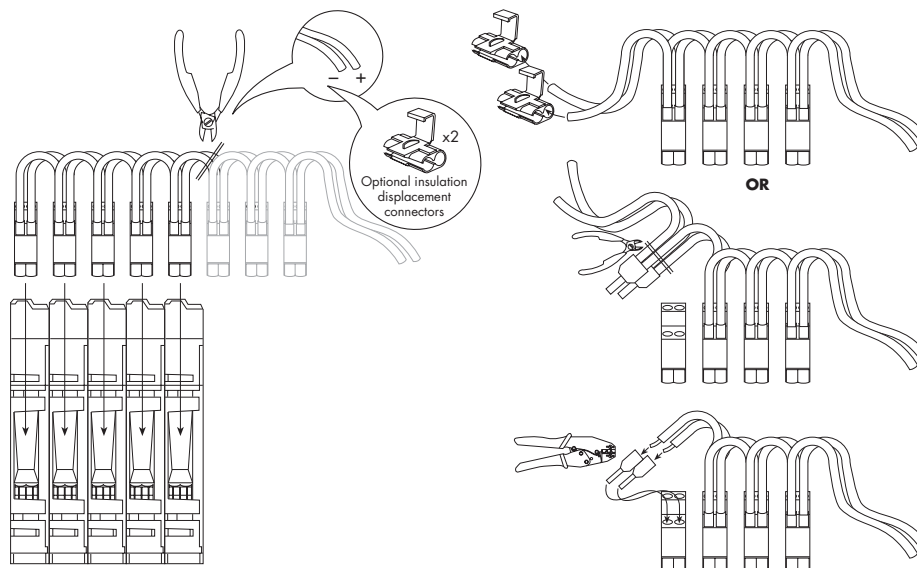

3.4 Earth rail and tagging accessories

This section explains how to specify and assemble earth rail and tagging strip accessories for the 9491-PS power supplies. The accessories consist of mounting brackets, earth rails, tagging strips and associated parts. They provide facilities for earthing, terminating cable screens and tagging (identifying) the positions of individual units.

3.4.1 Parts list

IMB57 Insulating mounting block (Figures 3.4, 3.5 & 3.6)

One required at each end of a tagging strip/earth rail. Suitable for low-profile (7.5mm) and high-profile (15mm) symmetrical DIN rail.

ERB57S Earth-rail bracket, straight (figure 3.10)

Nickel-plated bus bar; supplied with two push fasteners, one earth-rail clamp (14mm, 35mm²) and one earth cable clamp (10mm, 16mm²).

Note: ERB57S is the preferred choice of earth-rail bracket. It is usually fitted in the upper slot on insulating mounting block IMB57.

*Where the earth rail is required to be positioned at a lower height and to allow access to the IMB57 mounting screws, the straight earth-rail bracket ERB57S can be inserted in the lower slot, but only **after** insulating mounting blocks IMB57 are clamped to the DIN rail. This may not be possible if, for example, trunking is fitted. In this case, fit offset earth-rail bracket ERB570 (see figure 3.4 & 3.10) in the upper slot: the mounting blocks can then be fitted in a restricted space with this bracket already fitted.*

ERB570 Earth-rail bracket, offset (figure 3.10)

Nickel-plated bus bar; supplied with two push fasteners, one earth-rail clamp (14mm, 35mm²) and one earth cable clamp (10mm, 16mm²).

ERL7 Earth rail, 1m length (figure 3.10)

Nickel-plated bus bar; may be cut to length.

TAG57 Tagging strip, 1m length (figure 3.10)

Cut to size. Supplied with tagging strip label.

TGL57 Tagging strip labels, set of 10 x 0.5m

Spares replacement, for use with TAG57 tagging strip.

MS010 DIN rail module spacer, 10mm, pack of 5 (figure 3.8)

Grey spacer; one required between each 9491-PS and any adjacent module on a DIN rail, to provide 10mm air-circulation space between modules.

ETM7 Earth terminal, bag of 50 (figure 3.9)

For terminating cable screens and OV returns on the ERL7 earth rail. For cables ≤ 4mm².

TH5000 Tag holder

Spares replacement.

Connectors

Spares replacement: HAZ1-3, HAZ4-6, HAZ-CJC, PWR5000, SAF7-9, SAF10-12 (SAF1-3 and SAF4-6 grey connectors, also available for use in safe-area applications).

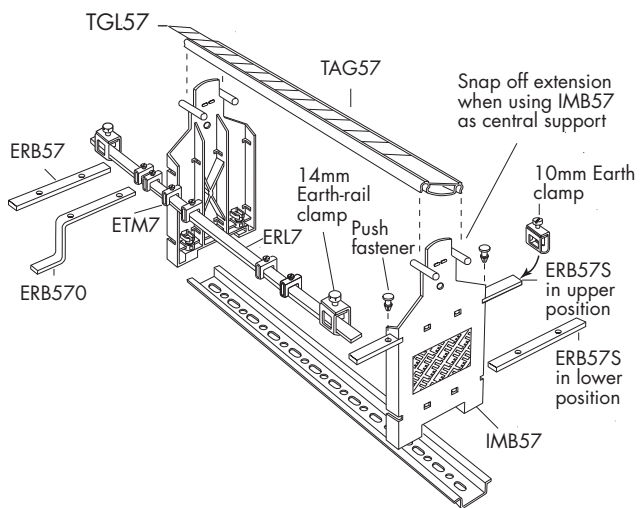

Figure 3.4: Assembly drawing showing part numbers

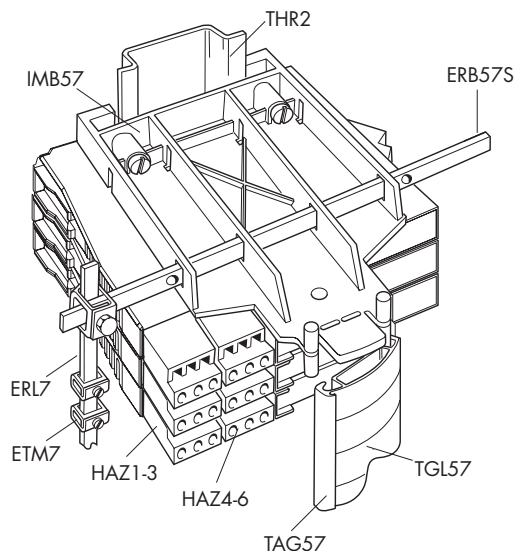

Figure 3.5: Mounting details

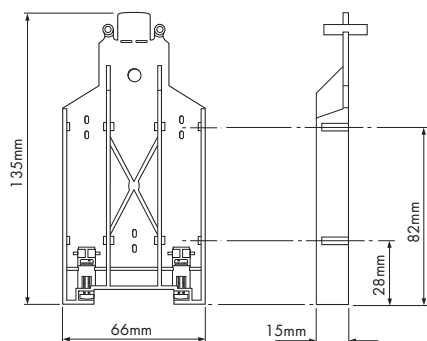

Figure 3.6: IMB57 Insulating mounting block

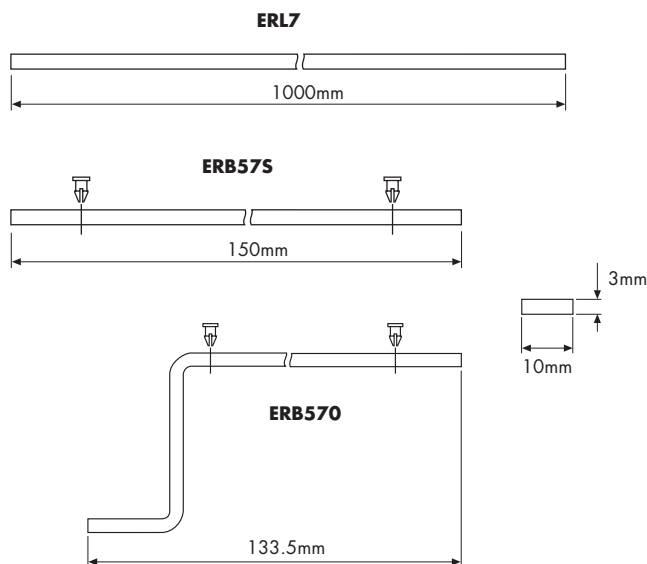

Figure 3.7: TAG57 Tagging strip, 1m length



Figure 3.8: MS010 DIN rail module spacers

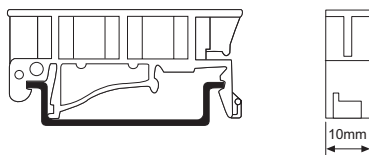

Figure 3.9: ETM7 Earth terminals

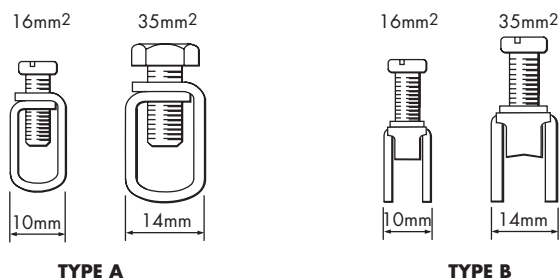

Figure 3.10: Earth rails and clamps

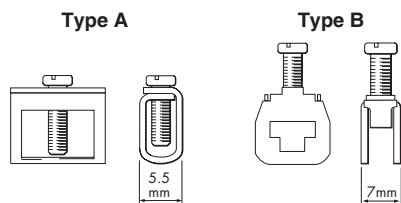

Figure 3.9: ETM7 Earth terminals

3.5 Assembly

3.5.1 Fitting earth rails

a) In upper position

Before fitting insulating mounting blocks IMB57, check that the swing nuts in the base of each unit are turned back into the moulding. Locate the mounting blocks on the DIN rail in the chosen position and tighten the screws (see figure 3.11). Check that the swing nuts rotate correctly to locate underneath the flanges of the DIN rail.

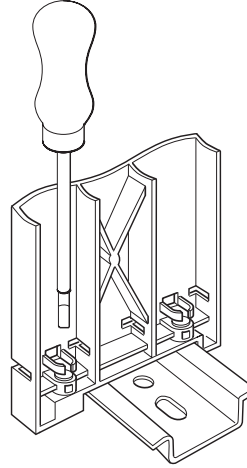

Figure 3.11:
Fitting IMB57

Slide a straight earth-rail bracket ERB57S into the upper slot in each mounting block. Push two plastic push fasteners into each bracket to locate the brackets in the mounting blocks.

Cut earth rail ERL7 to the length needed. Slide the required number of ETM7 earth terminals (5mm or 7mm wide) onto the rail. Clamp each end of the earth rail to earth-rail brackets ERB57S using the terminal clamps (14mm, 35mm²) supplied. Fit an earth clamp (10mm, 16mm²) to the free end of each earth-rail bracket.

Note: For lengths of earth-rail greater than 500mm, provide additional support by installing a third IMB57 mounting block and earth-rail bracket, mid-way between the end mounting blocks. Snap out the perforated extension between the lugs on this mounting block if a continuous tagging strip is to be fitted (see figure 3.4).

b) In lower position, where at least 150mm clearance exists on one side, measured from the edge of the mounting block.

As for a), but slide earth-rail brackets ERB57S into the lower slots in each mounting block.

c) In lower position, where there is insufficient clearance to fit earth-rail brackets ERB57S.

As for a), but slide offset earth-rail brackets ERB57O into the upper slot in each mounting block before assembling the mounting blocks to the DIN rail. ERB57S brackets cannot be used because they obscure the mounting blocks' fixing screws.

3.5.2 Fitting tagging strips

Assemble mounting blocks IMB57 to the DIN rail as above. Cut TAG57 tagging strip and label to the length needed, and insert label so that the appropriate side is visible. Clip the strip onto the lugs on the mounting blocks. Hinge up the strip to provide access to the tops of the power supplies.

Note: If necessary, provide additional support for long lengths of tagging strip by installing an extra IMB57 mounting block mid-way between the end mounting blocks. Snap out the perforated extension between the lugs on this mounting block.

3.5.3 Completed assemblies

Figure 3.12 illustrates a complete assembly of 9491-PS power supplies using the accessories mentioned above.

The broken-line boxes either side of the assembly represent cable trunking, and the accompanying dimensions represent the minimum spacing between trunking and assemblies.

Figure 3.12:
9491-PS
power supplies-
complete assembly

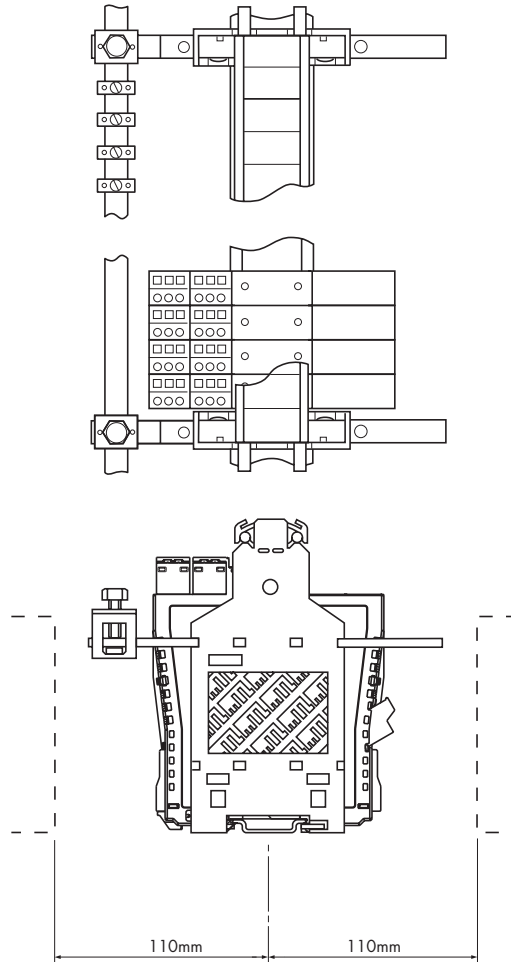

4 BACKPLANE MOUNTING METHOD

The alternative to DIN-rail mounting is to use a standard MTL backplane that accommodates 8 modules with 24V dc dual redundant power supplies. In applications where a number of backplanes are installed, the power supply can be interconnected. Optional earth-rail and tagging-strip kits are available for the backplanes.



WARNING: If this module is to be connected to intrinsically safe apparatus, it must be installed, operated and maintained only by trained competent personnel and in accordance with all appropriate international, national and local standard codes of practice and site regulation and in accordance with the instructions contained here.

4.1 Accessories

Accessories are available that enable the user to mount the backplanes. These include surface-mounting kits, T-section and G-section DIN-rail mounting kits and end stops.

MOUNTING KITS			ACCESSORIES		
Surface	DIN-rail (T or G)	19-inch rack	Earth-rail kit	Tagging strip kit	Spare fuse pack
SMS01	DMK01	–	ERK08–	TSK08	FUS08

4.2 Protection of equipment

When the power supply is mounted in a safe area ensure that the local environment is clean and free of dirt and dust and note the ambient temperature considerations given in Section 5.



WARNING: When mounted in a Zone 2 hazardous area the module *must* be protected by a suitably certified enclosure. See the *Special Conditions for Safe Use* provided in the ATEX Safety Instructions at the end of this manual for further details of operation in Zone 2 hazardous areas.

4.3 Backplane mounting

See the table for details of the kits and accessories applicable to the mounting methods and Figure 4.1 for dimensions and mounting centres.

Note: Before mounting a 9491-PS on a backplane two minor modifications must be made.

1. Remove the DIN-rail mounting clip by compressing the small spring inside the clip with a screwdriver and then removing it; the clip may then be removed easily from its mounting.
2. Remove the power supply plug located in the side of the unit, then fit the small plastic plate supplied to cover the hole in the module case.

Figure 4.1:
CPS08 backplane
for 9491-PS
modules

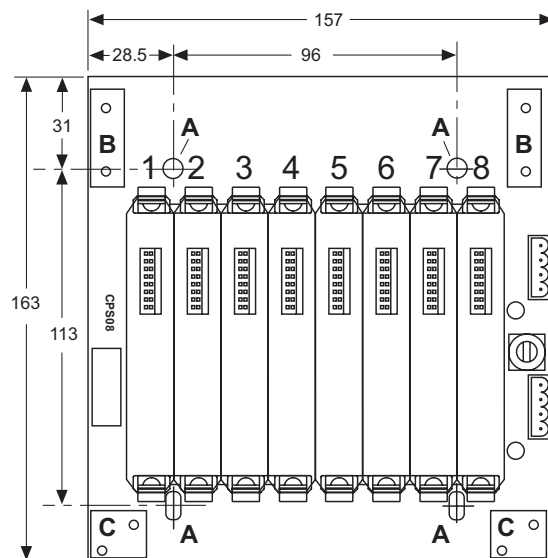

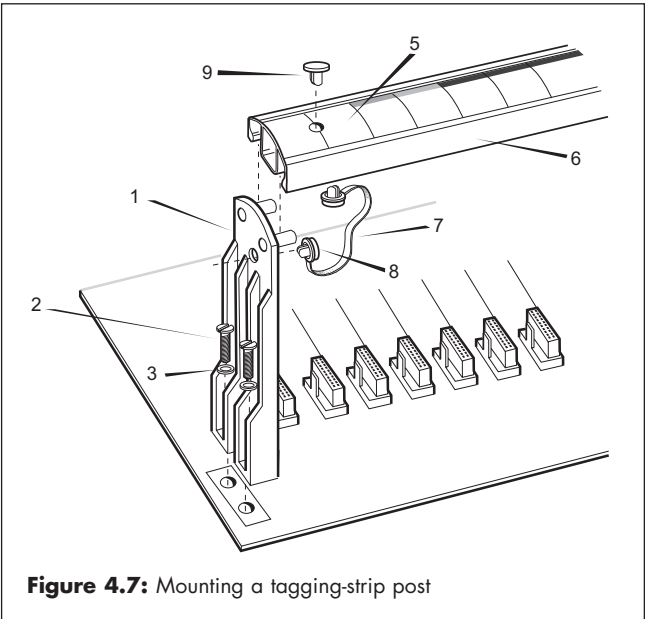
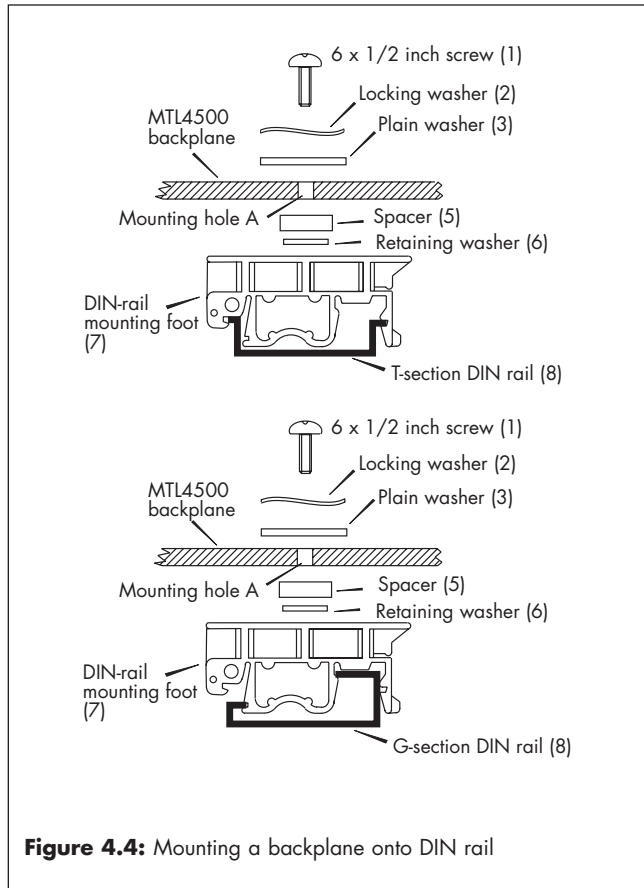
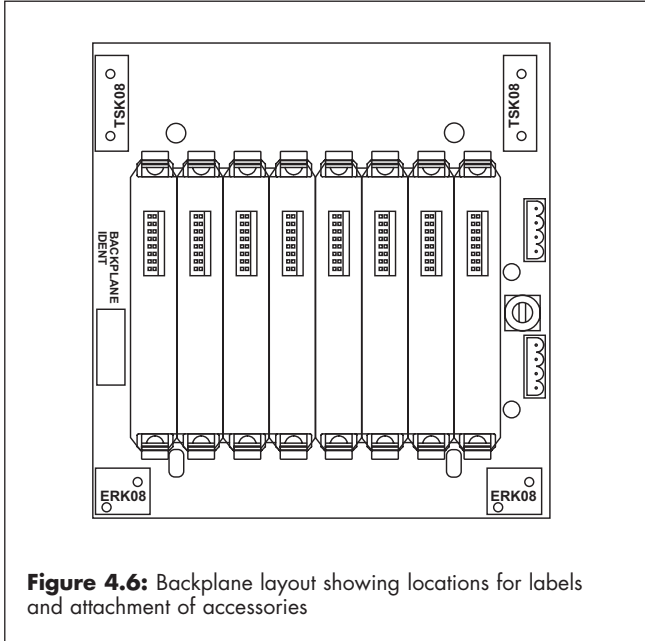
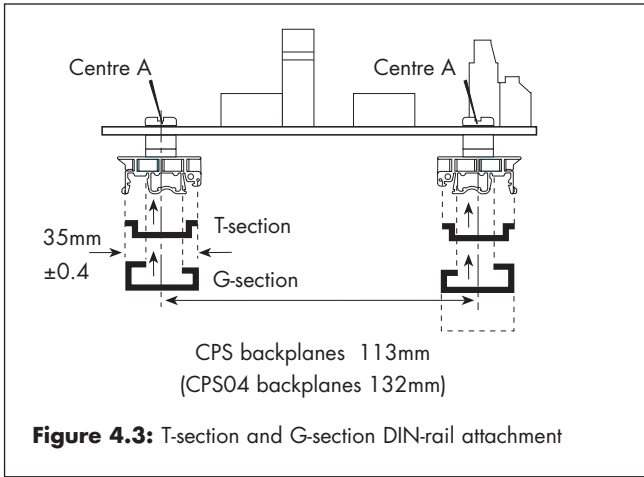
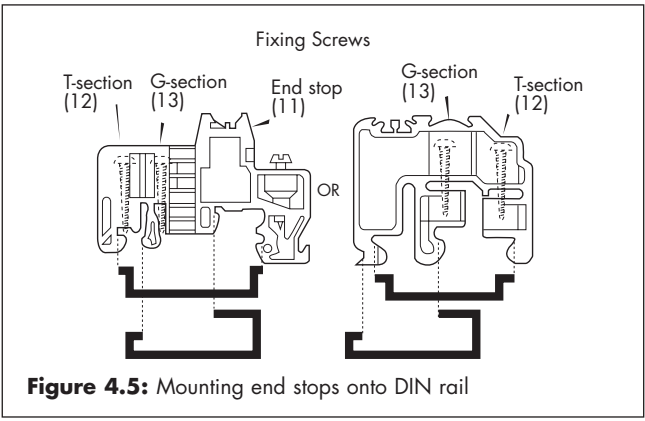
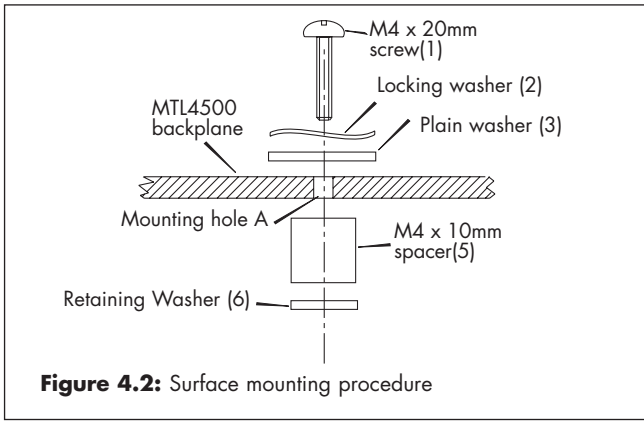

4.3.1 Surface mounting – with kit SMS01

See Figures 4.1 and 4.2.

- a) Select four M4 x 20mm screws.
- b) Prepare holes in the surface at centres A, tapping these if retaining nuts are not required (Figure 4.1).
- c) Place a locking washer (2) and a plain washer (3) over each M4 x 20mm screw (1) (Figure 4.2).
- d) Insert the screws through the backplane at each mounting centre A (Figures 4.1 and 4.2).
- e) Fit M4 x 10mm spacers (5), retaining them with retaining washers (6) (Figure 4.2).
- f) Attach the assemblies into the pre-drilled surface holes at centres A, retaining the screws with a suitable nut if the holes are not tapped.

4.3.2 T- or G-section DIN-rail mounting –with kit DMK01

See Figures 4.1, 4.3, 4.4 and 4.5.

- a) Select two pieces of T- or G-section DIN-rail of the appropriate length.
- b) Mount the two lengths of DIN-rail side-by-side at centres A, 113mm apart (Figure 4.1).
- c) Clip four mounting feet (7) to the DIN rail (8) at centres A (Figure 4.4).
- d) Select the appropriate number of No. 6 x 1/2-inch screws.
- e) Place a locking washer (2) and a plain washer (3) onto each No. 6 x 1/2-inch screw (1) (Figure 4.4).
- f) Insert the assemblies through the mounting holes A on the backplane (Figures 4.1 and 4.4).
- g) Fit spacers (5), retaining them with the washers (6) (Figure 4.4).
- h) Locate the assemblies over the mounting feet and attach the screws (1) to the feet (Figure 4.4).
- i) For backplanes that are mounted in a vertical orientation, attach one end stop (11) to the lower end of each DIN-rail supporting a column of backplanes by clipping the stops into place and tightening the appropriate screw [(12) for T-section and (13) for G-section DIN-rails] (Figure 4.5).
- j) Additional end stops should be attached between backplanes to increase the stability of tall columns of backplanes.

4.4 Backplanes – identification and tagging

Marked areas are provided for identifying backplanes. Mounting holes for earth-rail and tagging-strip attachments are similarly marked.

4.4.1 Backplane identification labels

- a) Attach a suitably marked label to the area marked BACKPLANE IDENT. to identify an individual backplane. See Figure 4.6.

4.4.2 Tagging strip mounting kit (TSK08)

See Figures 4.1, 4.9, 4.10 and 4.11.

- a) Locate the tagging strip mounting posts (1) at backplane centres B (Figure 4.1).
- b) Attach each mounting post (1) to the backplane with two M3 x 12mm mounting screws (2) and washers (3) (Figure 4.7).
- c) Slide the tag label (5) into the plastic holder (6) and retain with a plastic rivet (9) (Figure 4.7).
- d) Attach the plastic retaining tie (7) with two plastic rivets (8) (Figure 4.7).
- e) Clip the tag strip holder (6) onto the mounting posts (1) by pushing it downwards (Figure 4.8).
- f) If required, swivel the tagging strip vertically (Figure 4.9)

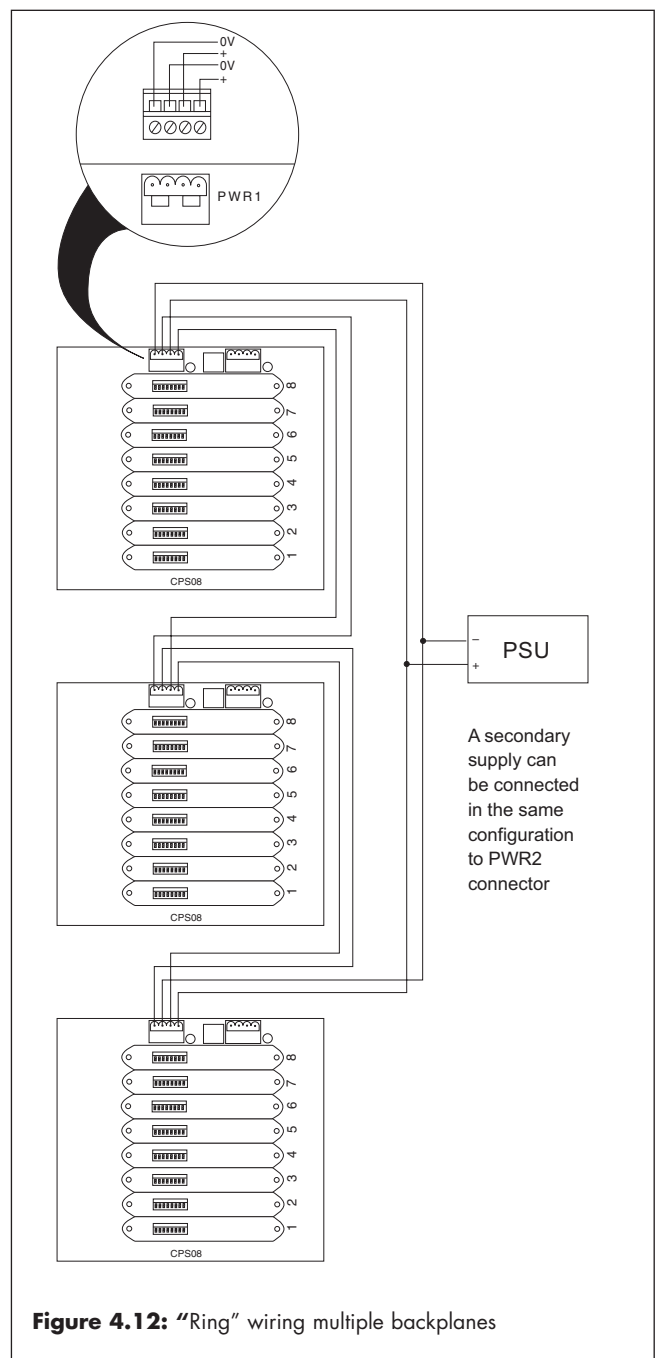
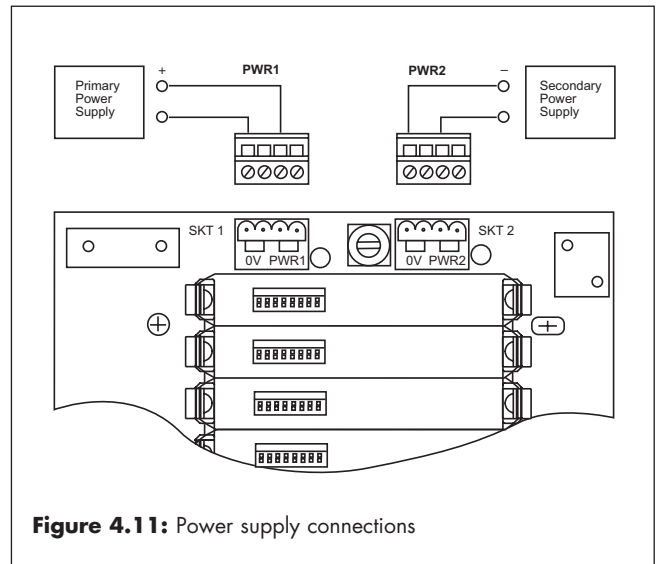
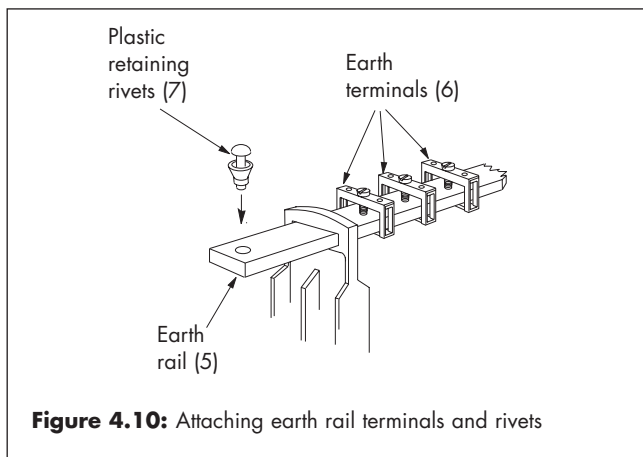
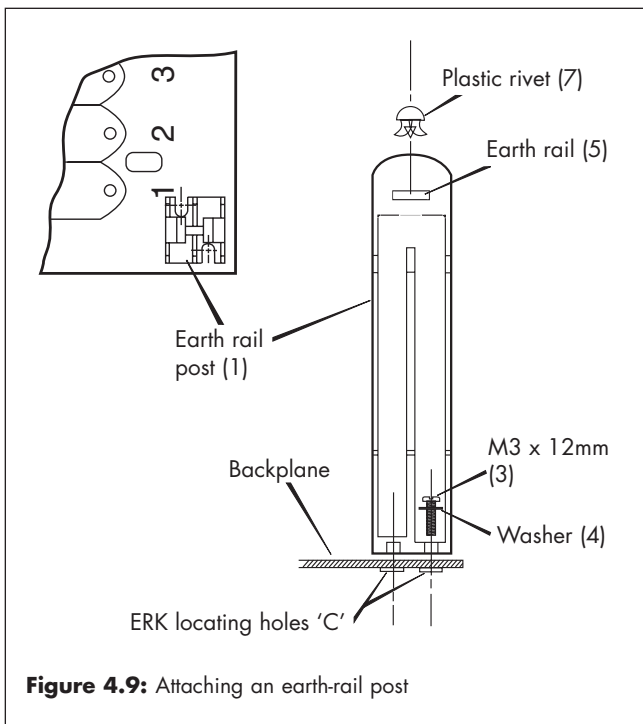
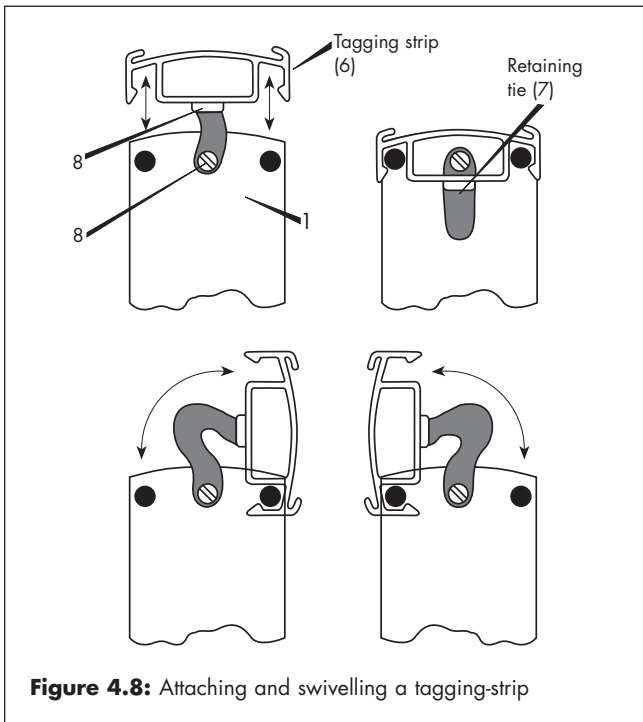

4.5 Backplanes - earth rails

Optional earth rails are available for backplanes (kit ERK08). Cable screens from hazardous-area circuits, or spare pairs from a multicore cable, are connected to the terminals on the earth rails, which are mounted on the backplane at about the same height as the front of the modules, close to the hazardous-area connectors. Earth rails are attached using the following procedure:–

4.5.1 Earth rail kit (ERK08)

See Figures 4.1, 4.9 and 4.10.

- a) Locate the earth rail mounting posts (1) at backplane centres C (Figures 4.1 and 4.9).
- b) Attach the mounting posts (1) with M3 x 12 screws (3) and washers (4) (Figure 4.9).
- c) Slide the earth rail (5) through the slots in the of the mounting posts (1) (Figure 4.10).
- d) Fit the earth terminal(s) (6) on the rail (5) (Figure 4.10).
- e) Attach plastic retaining rivets (7) to each end of the earth rail (5) (Figure 4.10).

4.6 Backplanes – power supply connections

4.6.1 Single backplane

Dual 24V power supplies, to provide redundancy, are routed to the backplane by plug-in connectors and then bussed by the backplane to individual power supply modules. LEDs on the backplane indicate that the two supplies are operational. A diode circuit between the two ensures that the highest voltage supply is the one in use at any given moment, so providing automatic switchover of supplies if the primary source fails. The procedure for connecting power supplies is:–

- a) Connect each of the two 21V to 35V dc power supply connectors to the independent supply sources according to the terminal assignments shown in Figure 4.11. The maximum permissible wire size is 2.5mm² (14 AWG).
- b) Plug the power supply connectors into the base connectors on the backplanes.
- c) The rating for the fuse located between the two supply connectors on the backplanes is 1A.-

4.6.2 Interconnection of power supplies for multiple backplanes

Power supplies for backplanes can be interconnected in the form of a ring. This will reduce wiring and also permit individual backplanes to be taken out of service without affecting supplies to other backplanes. More than one backplane can be removed, provided that they are neighbours and do not leave any other backplanes without an active supply.

- a) Make the connections shown in Figure 4.12.

Wire sizes up to 2.5mm² (14 AWG) can be used and should be chosen according to load and voltage drop.

4.7 Fitting 9491-PS modules to backplane

WARNING: When installing 9491-PS power supply modules it is essential to make sure that intrinsically safe and non-intrinsically safe wiring is segregated as required by a nationally accepted authority or as described in BS EN 60079-14, ISA RP 12.6 or DIN VDE-165.

4.7.1 Installation - Figure 4.15

- a) Trim insulation to suit bare or ferrule wire end (Figure 4.13)
- b) Terminate IS power (PoEx) wiring on blue connector(s).
- c) Mount interface unit on the backplane.
- d) Locate input bulk power connector(s) on backplane safe-area/power supply connector(s).

4.7.2 Module removal - Figure 4.16

- a) Unclip the latch nearest the CE mark on the module label.
- b) Rotate the module away from this latch.
- c) When the module is unplugged from the power connector, move the module clear of the other latch and remove.

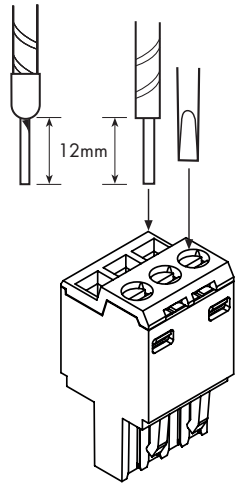

Figure 4.13: Wiring hazardous-area power output plugs

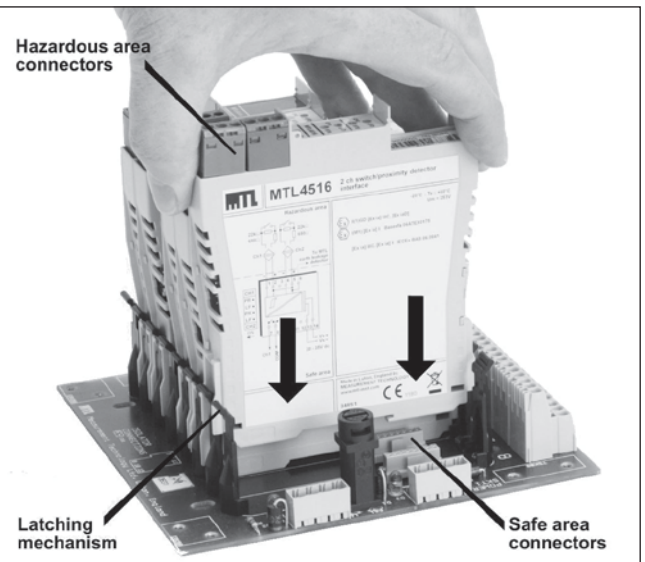

Figure 4.15: Fitting power supplies to backplane

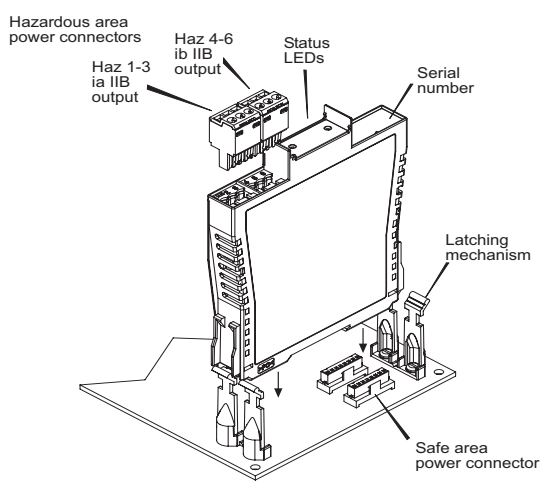

Figure 4.14: Key elements of the 9491-PS power supply

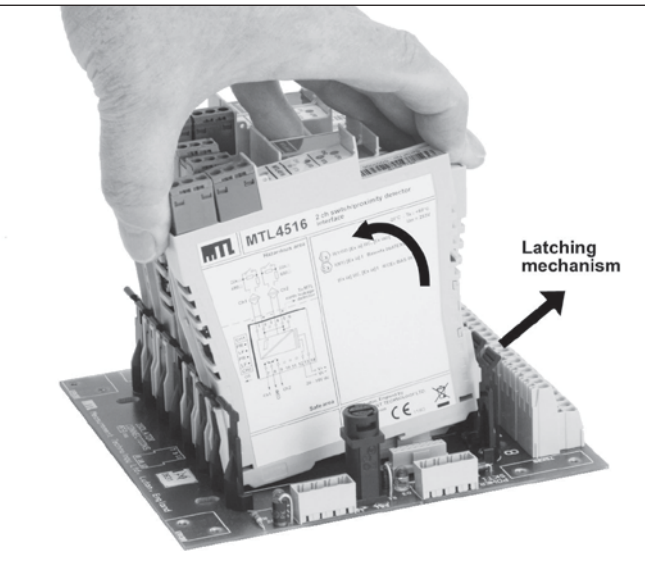

Figure 4.16: Removing power supplies from backplane

5 ENVIRONMENTAL

Operating Temperature	0°C...+70°C
Storage Temperature	-20°C...+70°C
Humidity	5...95% RH, non condensing

6 WASTE REMOVAL INFORMATION



The electronic equipment within must not be treated as general waste. By ensuring that this product is disposed of correctly you will be helping to prevent potentially negative consequences for the environment and human health, which could otherwise be caused by incorrect waste handling of this product.

For more detailed information about the take-back and recycling contact **MTL**.

7 APPROVALS

The operating parameters must not exceed those as detailed on the certificate.

- 2004/108/EC EMC Directive
- 2006/95/EC Low Voltage Directive

Region	Europe (ATEX)	International IECEx	USA	Canada
Authority	SIRA	SIRA	FM	FMC
Standard	EN 60079-0: 2006, EN 60079-11: 2007, IEC 60079-26: 2006, EN 61241-0: 2006, IEC 61241-11: 2005	IEC 60079-0: 2004, IEC 60079-11: 2006, IEC 61241-0: 2004, IEC 61241-11: 2005	3600: 1998 3610: 2007 3810: 2005 ANSI/ISA-12.12.02: 2003 ANSI/ISA-61010.1: 2004	C22.2 No. 61010.1: 2004 C22.2 No. 157: 1992 CAN/CSA-E60079-0: 2007 CAN/CSA-E60079-11: 2002
Approved for	⊕ II (1/2) GD (Ga) [Ex ia] IIB (Gb) [Ex ib] IIB [Ex iaD] [Ex ibD] ⊕ I (M1/M2) (Ma) [Ex ia] I (Mb) [Ex ib] I Ta = 0°C to +70°C	(Ga) [Ex ia] IIB (Gb) [Ex ib] IIB [Ex iaD] [Ex ibD] (Ma) [Ex ia] I (Mb) [Ex ib] I Ta = 0°C to +70°C	AIS/I/1/CD/ Ta = 70°C Note 1 I/0/[AEx ia] IIB, Ta = 70°C Note 1 I/1/[AEx ib] IIB, Ta = 70°C Note 2	AIS/I/1/CD/ Ta = 70°C Note 1 I/0/[Ex ia] IIB, Ta = 70°C Note 1 I/1/[Ex ib] IIB, Ta = 70°C Note 1
Cert. no.	Sira 08ATEX2188	IECEX SIR 08.0072	3036457	3036457C
Standard	EN 60079-0: 2006, EN 60079-11: 2007, EN 60079-15: 2005, EN 60079-26: 2007, IEC 60079-0: 2007*,	IEC 60079-0: 2007-10, IEC 60079-11: 2006, IEC 60079-15: 2005-03, IEC 60079-26: 2006	3611: 2004	C22.2 No. 213:1987 CAN/CSA-E60079-15: 2002
Approved for	⊕ II 3G (1)G (2)G Ex nAc [ia] [ib] IIB T4 (Ta = 0°C to +70°C)	Ex nAc [ia] [ib] IIB T4 (Ta = 0°C to +70°C)	NI/I/2/CD/T4, Ta = 70°C I/2/AEx nA II T4, Ta = 70°C	NI/I/2/CD/T4, Ta = 70°C I/2/Ex nA II T4, Ta = 70°C
Cert. no.	Sira 08ATEX4310X	IECEX SIR 08.0117X	3036457	3036457C

* (for guidance on marking)

Notes

1. Terminals 1 and 3
2. Terminals 5 and 6

8 FM CERTIFICATION INFORMATION

Special Condition of Use - Factory Mutual USA

1. In Class I, Division 2 installations, the subject equipment shall be mounted within a tool-secured enclosure which is capable of accepting one or more of the Class I, Division 2 wiring methods specified in the National Electrical Code ANSI/NFPA 70.
2. In Class I, Zone 2 installations, the subject equipment shall be mounted within a tool-secured enclosure which is capable of accepting one or more of the Class I, Zone 2 wiring methods specified in the National Electrical Code ANSI/NFPA 70. The equipment shall be installed in an enclosure with a minimum ingress protection rating of IP54 unless the apparatus is intended to be afforded an equivalent degree of protection by location.
3. When optionally connecting the power supply module to an external backplane via connector X1 the following conditions apply:

The external backplane shall be fitted with two retention clips type MTL 012-533 (Honeywell part no. 51153961-100) that allow the power supply module to be 'clipped' to the backplane. The power supply module being 'clipped' to the backplane forms part of the hazardous location protection and as such the retention clips shall always be in place when the power supply module is energized.

Special Condition of Use - Factory Mutual Canada

1. In Class I, Division 2 installations, the subject equipment shall be mounted within a tool-secured enclosure which is capable of accepting one or more of the Class I, Division 2 wiring methods specified in the Canadian Electrical Code (C22. 1).
2. In Class I, Zone 2 installations, the subject equipment shall be mounted within a tool-secured enclosure which is capable of accepting one or more of the Class I, Zone 2 wiring methods specified in the Canadian Electrical Code (C22. 1). The equipment shall be installed in an enclosure with a minimum ingress protection rating of IP54 unless the apparatus is intended to be afforded an equivalent degree of protection by location.
3. When optionally connecting the power supply module to an external backplane via connector X1 the following conditions apply:

The external backplane shall be fitted with two retention clips type MTL 012-533 (Honeywell part no. 51153961-100) that allow the power supply module to be 'clipped' to the backplane. The power supply module being 'clipped' to the backplane forms part of the hazardous location protection and as such the retention clips shall always be in place when the power supply module is energized.

9 ATEX & IECEx CERTIFICATION INFORMATION

The following information is in accordance with the Essential Health and Safety Requirements (Annex II) of the EU Directive 94/9/EC [the ATEX Directive - safety of apparatus] and is provided for those locations where the ATEX Directive is applicable.

General

- a) This equipment must only be installed, operated and maintained by competent personnel. Such personnel shall have undergone training, which included instruction on the various types of protection and installation practices, the relevant rules and regulations, and on the general principles of area classification. Appropriate refresher training shall be given on a regular basis. [See clause 4.2 of EN 60079-17].
- b) This equipment has been designed to provide protection against all the relevant additional hazards referred to in Annex II of the directive, such as those in clause 1.2.7.
- c) This equipment has been designed to meet the requirements of intrinsically safe electrical apparatus in accordance with EN 60079-0, EN 60079-11, EN 60079-15 and EN 60079-26.

Installation

- a) reference to the IEC code of practice IEC 60079-14. In addition, particular industries or end users may have specific requirements relating to the safety of their installations and these requirements should also be met. For the majority of installations the Directive 1999/92/EC [the ATEX Directive - safety of installations] is also applicable.

continued on next page

- b) Unless already protected by design, this equipment must be protected by a suitable enclosure against:
 - i) mechanical and thermal stresses in excess of those noted in the certification documentation and the product specification.
 - ii) aggressive substances, excessive dust, moisture and other contaminants.
- c) This apparatus is intrinsically safe electrical apparatus and is normally mounted in a safe area. When mounted in a Zone 2 location the apparatus must be provided with an enclosure, which offers an additional degree of protection appropriate to the area classification.

Special conditions for safe use (when mounted in a Zone 2 hazardous area)

- a) The equipment shall be installed in an additional enclosure that is certified as meeting or exceeding the enclosure requirements of EN/IEC 60079-0 and EN/IEC 60079-15 (e.g. a certified Ex e enclosure). The minimum level of ingress protection provided shall be IP 54.
- b) When using the option to connect the power supply module to an external backplane via connector X1, the following conditions apply:
 - ◆ The external backplane shall be fitted with two retention clips type MTL 012-533 (Honeywell part no. 51153961-100) that allow the power supply module to be 'clipped' to the backplane.
 - ◆ The power supply module being 'clipped' to the backplane forms part of the hazardous area protection and as such the retention clips shall always be in place when the power supply module is energised.
 - ◆ Any backplane used does not form part of this certified equipment and as such shall be separately certified or assessed for use in Zone 2.
- c) The maximum current drawn from terminals 1, 3, 5 and 6 combined shall not exceed 480mA in normal operation.

Inspection and maintenance

- a) Inspection and maintenance should be carried out in accordance with European, national and local regulations which may refer to the IEC standard IEC 60079-17. In addition specific industries or end users may have specific requirements which should also be met.
- b) Access to the internal circuitry must not be made during operation.

Repair

This product cannot be repaired by the user and must be replaced with an equivalent certified product.

Marking

Each device is marked in accordance with the Directive and CE marked with the Notified Body Identification Number.

This information applies to products manufactured during or after the year 2010.

Figure 8.1
9491-PS
product label



9491-PS

DO NOT SEPARATE INPUT OR BACKPLANE
CONNECTOR WHEN ENERGISED

12VDC IS Power Supply Module

Safe Area Supply Input 24VDC (20-30V) 350mA
Nominal Output 12V 200mA 'ia', 400mA 'ib'

Safe Area Installation:
Associated Apparatus providing IS circuits for CL I, DIV 1, GP C-D (US);
Associated Equipment [Ex ia], CL I, DIV 1, GP C-D (Canada);
[AEx ia] IIB, [AEx ib] IIB (US); [Ex ia] IIB, [Ex ib] IIB (Canada);
Class 1 Zone 2/Division 2 Installation:
Provides IS circuits for CL I, DIV 1, GP C-D; CL I, DIV 2, GP C-D, T4;
CL I, ZN 2, AEx IA [ia IIB] [ib IIB] IIB T4 (US);
Ex IA [ia IIB] [ib IIB] IIB T4 (Canada);
Install per Control Drawing: 9491 System
Voltage: 20-30Vdc, Current: 350mA, Um = 253V

Sira 08ATEX2188 IECEx SIR 08.0072
Sira 08ATEX4310X IECEx SIR 08.0117X

(Ma) [Ex ia] I, (Mb) [Ex ib] I
[Ex iaD], [Ex ibD]
(Ga) [Ex ia] IIB, (Gb) [Ex ib] IIB
Ex nAc [ia] [ib] IIB T4

Serial No.

Made in Derbyshire, England
Controlled Systems Limited
In partnership with MEASUREMENT TECHNOLOGY LTD.

Hazardous Area Output Terminals

1 = +12V 'ia'
2 = n.c.
3 = 0V
4 = n.c.
5 = +12V 'ib'
6 = 0V

Safe Area Input Terminals

13 = 0Vin
14 = +24Vin
(or via Backplane)

Ta = 0°C to +70°C

CE 0518 

 APPROVED

H

HAZARDOUS (CLASSIFIED) LOCATION
Class I, Division 2, Groups C, D
Class I, Zone 2, Groups IIB, IIA

HAZARDOUS (CLASSIFIED) LOCATION
Class I, Division 1, Groups C, D
Class I, Zones 0 or 1, Groups IIB, IIA

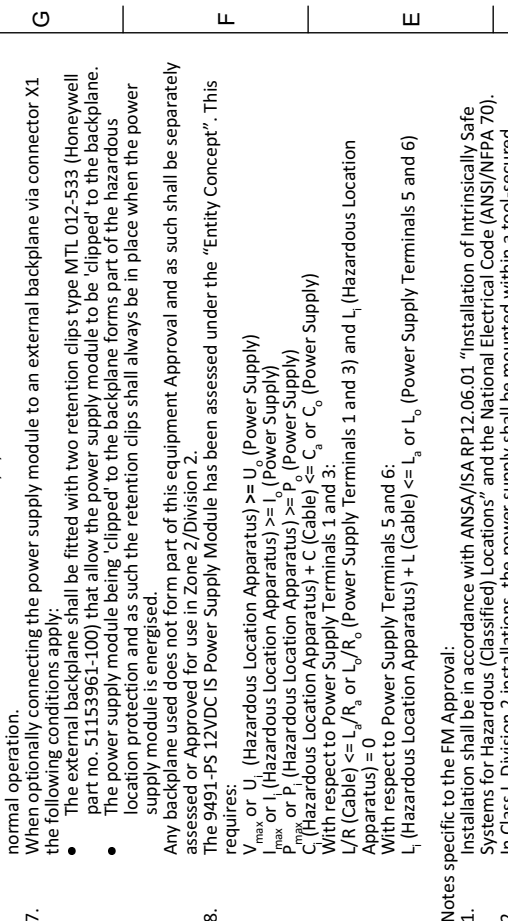

G

HAZARDOUS (CLASSIFIED) LOCATION
Class I, Division 2, Groups C, D
Class I, Zone 2, Groups IIB, IIA

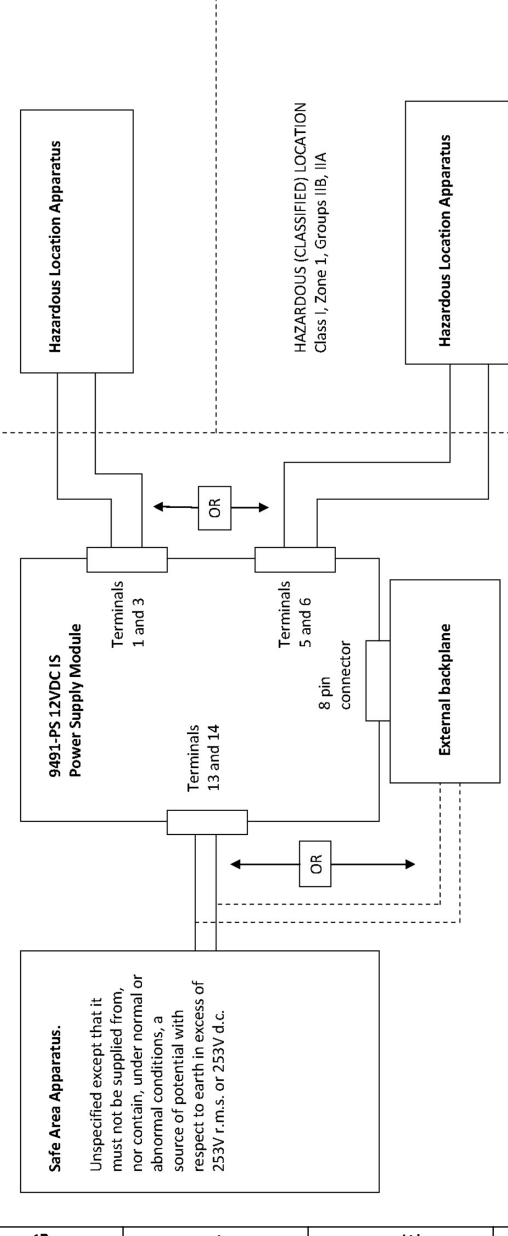

F

HAZARDOUS (CLASSIFIED) LOCATION
Class I, Division 2, Groups C, D
Class I, Zone 2, Groups IIB, IIA

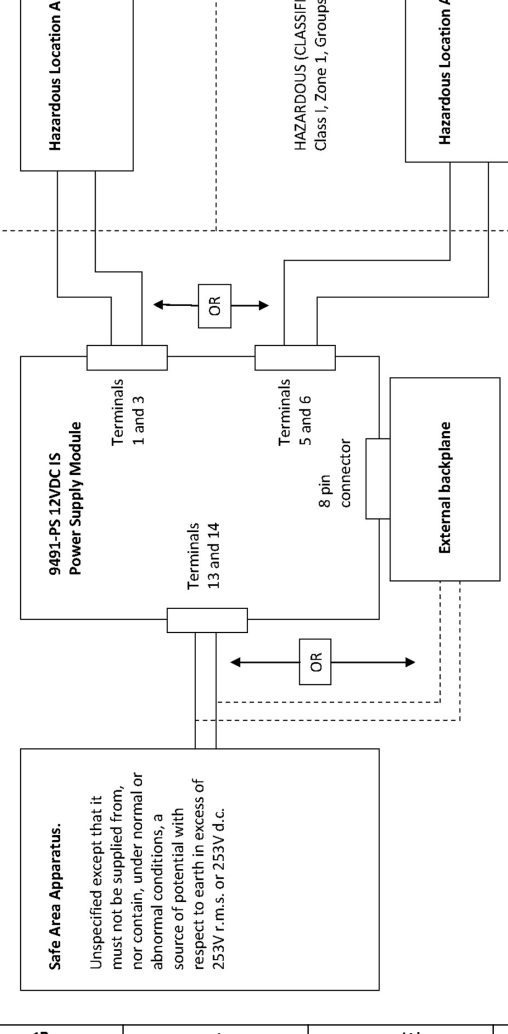

E

HAZARDOUS (CLASSIFIED) LOCATION
Class I, Division 2, Groups C, D
Class I, Zone 2, Groups IIB, IIA

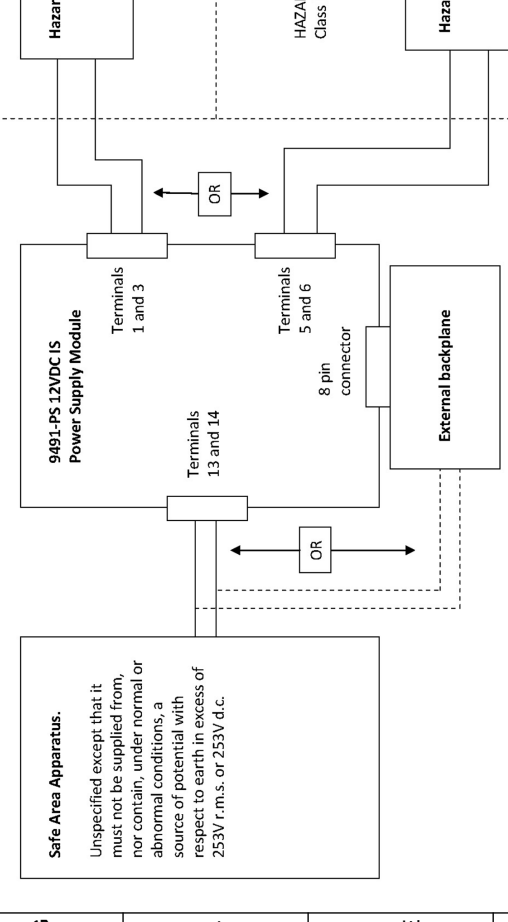

D

HAZARDOUS (CLASSIFIED) LOCATION
Class I, Division 2, Groups C, D
Class I, Zone 2, Groups IIB, IIA

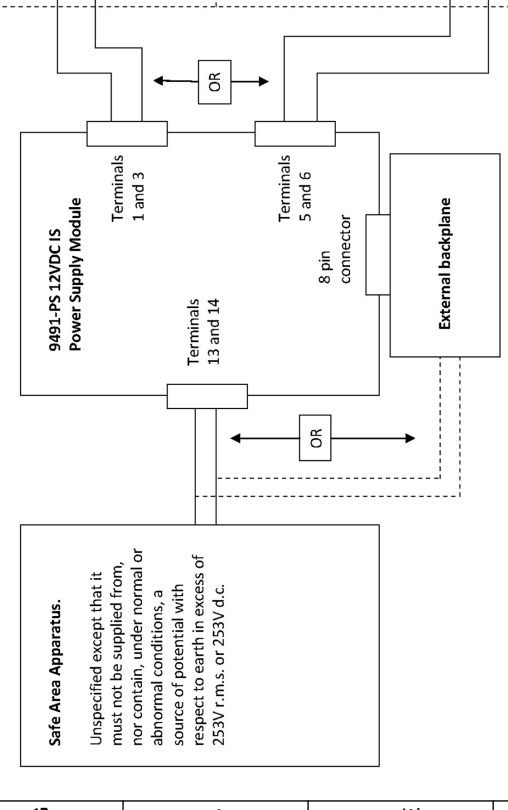

C

HAZARDOUS (CLASSIFIED) LOCATION
Class I, Division 2, Groups C, D
Class I, Zone 2, Groups IIB, IIA

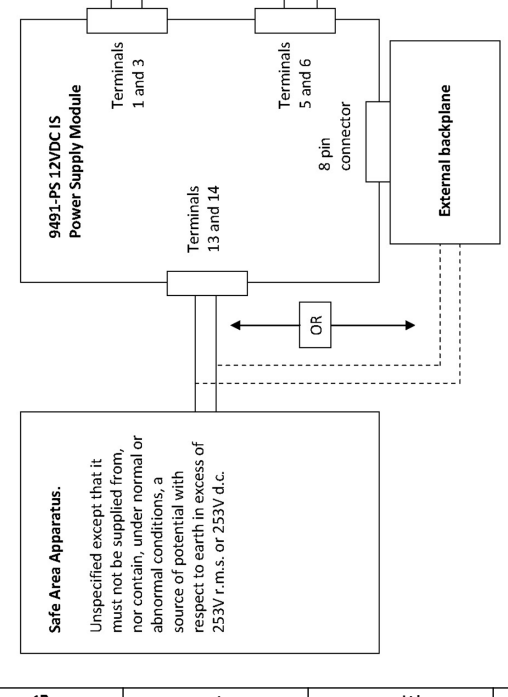

B

HAZARDOUS (CLASSIFIED) LOCATION
Class I, Division 2, Groups C, D
Class I, Zone 2, Groups IIB, IIA

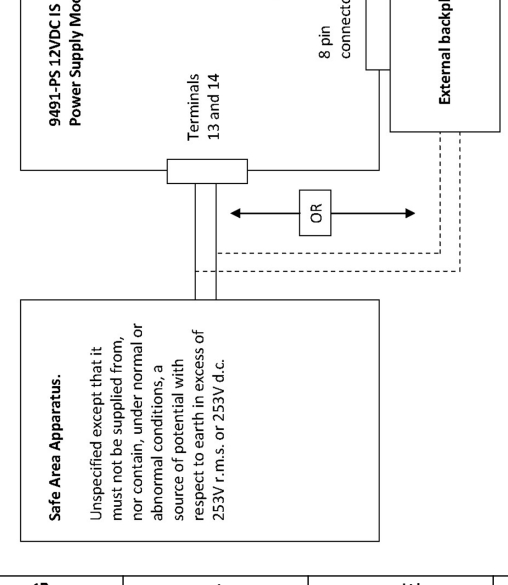

A

HAZARDOUS (CLASSIFIED) LOCATION
Class I, Division 2, Groups C, D
Class I, Zone 2, Groups IIB, IIA

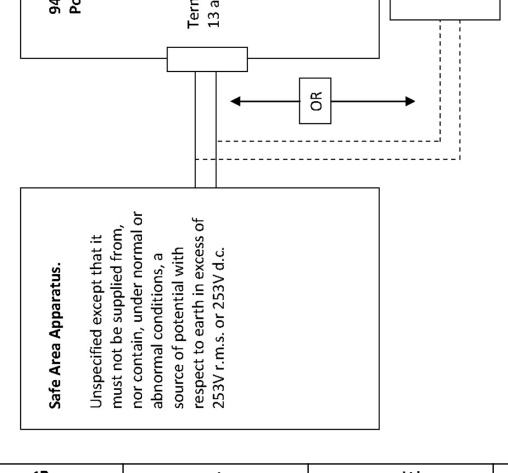

Entity parameters:

Terminals 13 and 14 or 8 pin connector	30V d.c.
Rated input voltage	253V
U_o or V_{oc}	12.4V
I_o or I_{oc}	2.67A
P_o	8.27W
C_o or C_s	Group IIB Class I, Group C 7.9µF
	Group IIA Class I, Group D 30µF
L_o/R_o or L_o/R_s	Group IIB Class I, Group C 17.2µH/Ω
	Group IIA Class I, Group D 34.4µH/Ω
Terminals 5 and 6 - 'ib' output (non-linear, active current 'switch-off', source)	
U_o or V_{oc}	12.4V
I_o or I_{oc}	505mA
P_o	6.3W
C_o or C_s	500nF
L_o or L_s	100µH

General notes:

- No revision to drawing without prior FM Approval.
- The supply output at terminals 5 and 6 of power supply is non-linear (active current 'switch-off').
- WARNING: Substitution of components may impair Intrinsic Safety.
- WARNING: To prevent ignition of flammable atmospheres, disconnect power before servicing.
- WARNING: Substitution of components may impair suitability for Division 2
- The maximum current drawn from Terminals 1, 3, 5 and 6 combined shall not exceed 480mA in normal operation.
- When optionally connecting the power supply module to an external backplane via connector X1 the following conditions apply:
 - The external backplane shall be fitted with two retention clips type MTL 012-533 (Honeywell part no. 51153961-100) that allow the power supply module to be 'clipped' to the backplane.
 - The power supply module being 'clipped' to the backplane forms part of the hazardous location protection and as such the retention clips shall always be in place when the power supply module is energised.
- Any backplane used does not form part of this equipment Approval and as such shall be separately assessed or Approved for use in Zone 2/Division 2.

Notes specific to the FM Approval:

- Installation shall be in accordance with ANSA/ISA RP 12.06.01 "Installation of Intrinsically Safe Systems for Hazardous (Classified) Locations" and the National Electrical Code (ANSI/NFPA 70).
- In Class I, Division 2 installations, the power supply shall be mounted within a tool-secured enclosure which is capable of accepting one or more of the Class I, Division 2 wiring methods specified in the National Electrical Code (ANSI/NFPA 70). This additional enclosure shall be capable of meeting the performance requirements of clause 5.0 of FM Class Number 3600 - November 1998.
- In Class I, Zone 2 installations, the power supply shall be mounted within a tool-secured enclosure which is capable of accepting one or more of the Class I, Zone 2 wiring methods specified in the National Electrical Code (ANSI/NFPA 70). This additional enclosure shall provide a minimum ingress protection rating of IP54 unless the apparatus is intended to be afforded an equivalent degree of protection by location. Any cable and conduit entries into this additional enclosure shall be in accordance with clause 7.1.3 and clause 7.1.4 of ANS/ISA-12.02-2003 (IEC 60079-15-1987).

Notes specific to the FMc Approval:

- Installation shall be in accordance with the Canadian Electrical Code (C22.1).
- In Class I, Division 2 installations, the power supply shall be mounted within a tool-secured enclosure which is capable of accepting one or more of the Class I, Division 2 wiring methods specified in the Canadian Electrical Code (C22.1).
- In Class I, Zone 2 installations, the power supply shall be mounted within a tool-secured enclosure which is capable of accepting one or more of the Class I, Zone 2 wiring methods specified in the Canadian Electrical Code (C22.1). This additional enclosure shall provide a minimum ingress protection rating of IP54 unless the power supply is intended to be afforded an equivalent degree of protection by location.

Requirements:

- V_o or U_o (Hazardous Location Apparatus) $\geq U_o$ (Power Supply)
- I_{max} or I_o (Hazardous Location Apparatus) $\geq I_o$ (Power Supply)
- P_{max} or P_o (Hazardous Location Apparatus) $\geq P_o$ (Power Supply)
- C_o (Hazardous Location Apparatus) + C (Cable) $\leq C_o$ or C_s (Power Supply)
- With respect to Power Supply Terminals 1 and 3:
 - L/R (Cable) $\leq L_o/R_o$ or L_o/R_s (Power Supply Terminals 1 and 3) and L_1 (Hazardous Location Apparatus) = 0
- With respect to Power Supply Terminals 5 and 6:
 - L_1 (Hazardous Location Apparatus) + L (Cable) $\leq L_o$ or L_s (Power Supply Terminals 5 and 6)

Control Drawing

DRAWN : IAC
DATE: 28/02/2010
SCALE
DWG NO 9491 System
REV 1

CONTROLLED SYSTEMS LTD.
SWADLINCOTE, DERBYSHIRE, ENGLAND

TITLE
9491-PS IS Power Supply
FM/FMc (Hazardous Location)

1 OF 2

NON-HAZARDOUS (UNCLASSIFIED) LOCATION (SAFE AREA)

HAZARDOUS (CLASSIFIED) LOCATION
Class I, Division 1, Groups C, D
Class I, Zones 0 or 1, Groups IIB, IIA

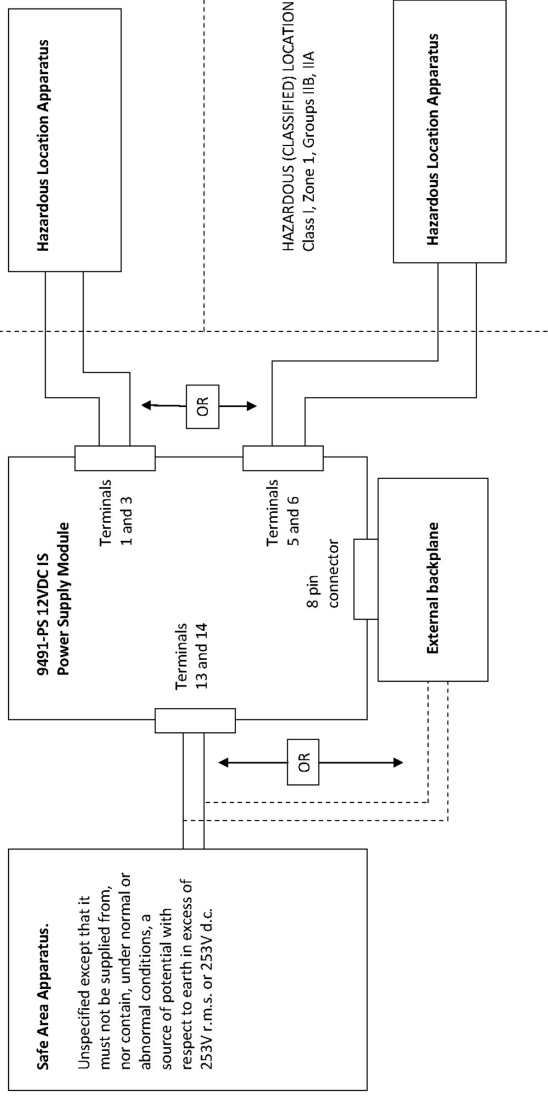

General notes:

1. No revision to drawing without prior FM Approval.
2. The supply output at terminals 5 and 6 of power supply is non-linear (active current 'switch-off').
3. Warning - Substitution of components may impair Intrinsic Safety.
4. Warning - To prevent ignition of flammable atmospheres, disconnect power before servicing.
5. The 9491-PS 12VDC IS Power Supply Module has been assessed under the "Entity Concept". This requires:

V_{max} or U_i (Hazardous Location Apparatus) $\geq U_o$ (Power Supply)
 I_{max} or I_i (Hazardous Location Apparatus) $\geq I_o$ (Power Supply)
 P_{max} or P_i (Hazardous Location Apparatus) $\geq P_o$ (Power Supply)
 C_i (Hazardous Location Apparatus) + C (Cable) $\leq C_a$ or C_o (Power Supply)
 With respect to Power Supply Terminals 1 and 3:
 L/R (Cable) $\leq L_a/R_a$ or L_o/R_o (Power Supply Terminals 1 and 3) and L_i
 (Hazardous Location Apparatus) = 0
 With respect to Power Supply Terminals 5 and 6:
 L_i (Hazardous Location Apparatus) + L (Cable) $\leq L_a$ or L_o (Power Supply Terminals 5 and 6)

Notes specific to the FM Approval:

1. Installation shall be in accordance with ANSA/ISA RP12.06.01 "Installation of Intrinsically Safe Systems for Hazardous (Classified) Locations" and the National Electrical Code (ANSI/NFPA 70).

Notes specific to the FMc Approval:

1. In Class I, Division 1 installations, the power supply shall be either installed where it is not exposed to falling moisture, weather, streams of water or dust or shall be fitted in an addition enclosure that complies with the requirements of CSA Enclosures Types 2, 3, 4 or 5 as outlined in CSA Standard C22.2 No. 94.
2. Installation shall be in accordance with the Canadian Electrical Code (C22.1).

Entity parameters:

Terminals 13 and 14 or 8 pin connector	30V d.c.
Rated input voltage	253V
U_m	253V
Terminals 1 and 3 - 'ia' output (linear characteristic, resistive current limit, source)	
U_o or V_{oc}	12.4V
I_o or I_{sc}	2.67A
P_o	8.27W
C_o or C_a	Group IIB Class I, Group C
	7.9µF
	Group IIA Class I, Group D
	30µF
L_a/R_a or L_o/R_o	Group IIB Class I, Group C
	17.2µH/Ω
	Group IIA Class I, Group D
	34.4µH/Ω
Terminals 5 and 6 - 'ib' output (non-linear, active current 'switch-off', source)	
U_o or V_{oc}	12.4V
I_o or I_{sc}	505mA
P_o	6.3W
C_o or C_a	500nF
L_o or L_a	100µH

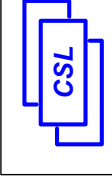

DRAWN : IAC
DATE: 28/02/2010

CONTROLLED SYSTEMS LTD. SWADLINCOTE, DERBYSHIRE, ENGLAND	
TITLE	9491-PS IS Power Supply FM/FMc (Non-Hazardous Location) Control Drawing
SIZE	DWG NO
A3	9491 System
SCALE	SHEET
	1
	2 OF 2

MTL Instruments Pty Limited

9 /12 Billabong Street
Stafford
Queensland 4053
Australia
Tel: + 61 1300 308 374 Fax: + 61 1300 308 463
E-mail: enquiries@mtlaus.com.au

Cooper Electric (Shanghai) Co.Ltd.

Room 2001, China Life Tower
16 Chao Yang Men Wai Street
Chao Yang District, Beijing
China 100020
Tel: + 86 10 5980 0288 Fax: + 86 10 8562 5725
E-mail: bjsales@mtl-inst.cn

MTL Instruments sarl

Les Carrés du Parc
10 rue des Rosiéristes
69410 Champagne au Mont d'Or
France
Tel: +33 (0)4 78 64 98 32 Fax: +33 (0)4 78 35 79 41
E-mail: info@mtl-inst.fr

MTL Instruments GmbH

An der Gumpgesbrücke 17
D-41564 Kaarst
Germany
Tel: +49 (0)2131 718930 Fax: +49 (0)2131 7189333
E-mail: info@mtl.de

MTL India

No. 36, Nehru Street
Off Old Mahabalipuram Road
Sholinganallur
Chennai - 600 119
India
Tel: + 91 (0)44 24501660/24501857 Fax: + 91 (0)44 24501463
E-mail: sales@mtlindia.com

MTL Italia srl

Via Cantù 11
I - 20092 Cinisello Balsamo MI
Italy
Tel: +39 (0)2 61802011 Fax: +39 (0)2 61294560
E-mail: info@mtl-inst.it

MTL Instruments KK

MT Building 3F
2-7-5 Shiba Daimon
Minato-ku Tokyo
Japan 105-0012
Tel: +81 (0)3 6430 3128 Fax: +81 (0)3 6430 3129
E-mail: sales@mtlkk.co.jp

Cooper Crouse-Hinds Korea

12F, Vision Tower
707-2 Yeoksam-dong, Gangnam-gu
Seoul 135-080
South Korea
Tel: +82 2 3484 6795 Fax: +82 2 3484 6778

MTL Instruments BV

MTL Instruments BV
Terheijdensweg 465
4825BK Breda
The Netherlands
Tel: +31(0)76 7505360 Fax: +31(0)76 7505370
E-mail: info@mtlbenelux.com

Cooper Crouse-Hinds Pte Ltd

No.2 Serangoon North Avenue 5
#06-01 Fu Yu Building
Singapore 554911
Tel: +65 6 487 7887 Fax: +65 6 487 7997
E-mail: sales@mtlsing.com.sg

MTL Instruments

Villa No. 4, Sector 2-17, Street 6
PO Box 53234,
Abu Dhabi, UAE
Tel: +971 2 446 6840 Fax: +971 2 446 6841
E-mail: mtlgulf@mtl-inst.com

Measurement Technology Limited

Great Marlings, Butterfield, Luton, Beds
England LU2 8DL
Tel: +44 (0)1582 723633 Fax: +44 (0)1582 422283
E-mail: enquiry@mtl-inst.com

MTL Incorporated

3413 N. Sam Houston Parkway W.
Suite 210
Houston TX 77086
USA
Tel: +1 281 571 8065 Fax: +1 281 571 8069
E-mail: csinfo@mtl-inst.com

