



## AS-TX

AS Series Conductivity Sensor  
with direct 4-20mA output



Installation and Operation Manual

## Contents

1	Introduction .....	3
2	Safety .....	3
3	Specifications .....	4
4	Setup .....	5
	Wiring to the controller .....	5
5	Mounting .....	5
	General Installation Requirements .....	5
	Submersion Mounting with the AM-ARM-5 .....	5
	Inline Mounting with the AM-TEE-5 .....	6
6	Operation .....	8
	Maintenance .....	8
	Digital Communication .....	8
	Wiring .....	8
	PC configuration: .....	9
	CLI Commands: .....	10
	Conductivity Range Selection .....	11
7	User Calibration .....	11
	One Point Calibration Using PLC .....	12
	Calibrating By Adjusting PLC Range .....	12
	One Point Calibration Using RS485 .....	12
	Current Calibration .....	13
8	In Field Upgrade: .....	14
9	Disposal .....	15
10	Warranty .....	15
11	Contact .....	15

## 1 Introduction

The AS-TX is a third-generation conductivity sensor built on the 50-year AquaMetrix legacy of building durable and easy-to-use sensors. It is designed to work with our AquaMetrix 2300 as well as virtually any PLC controller with 4-20mA input.

Water Analytics built on design experience and feedback from its customers to bring to market the AS-TX sensor. Some of the design improvements include:

1. Only “smart” contacting conductivity sensor on the market
2. Form factor that enables both inline and submersible mounting
3. Loop powered, direct 4-20 mA output
4. Compatible with virtually any PLC controller

## 2 Safety



### **WARNING**

**Electrical hazard:** Do not install the probe unless you have electrical training and you have read the instruction manual. The probe uses a nominal 24V, 16-32V, power supply and improper installation, and handling can result in injury or damage to surrounding equipment including this probe.



### **NOTICE**

**The probe should only be installed, stored, and serviced in the manner described in this manual. Improper handling may result in damage to the unit and surrounding equipment and may void the warranty.**

### 3 Specifications

Probe Parameters	
Sensor type	Conductivity
Wetted materials	CVPC Body Electrodes: 316 SS (cell constants 0.1 and 01) or graphite (cell constants 10)
Temperature Elements	Embedded
Measurement Range	10-200 $\mu\text{S}/\text{cm}$ (cell constant 0.1) 100-2,000 $\mu\text{S}/\text{cm}$ (cell constant 1) 1,000-25,000 $\mu\text{S}/\text{cm}$ (cell constant 10)
Calibration Mode	Factory calibrated Optional 1-Point in-situ calibration User-configurable 4 & 20 mA points and temperature coefficient
Ratings	
Voltage	24VDC nominal, 16-32VDC (depending on the loop resistor)
Ingress Protection	Fully submersible, NEMA 6 (IP68)
Temperature	-20 to 75°C (-4 to 167°F)
Physical	
Mounting Options	Inline or submersion
Cable Length	15 ft standard, Custom length available
Dimensions	Length 7.6", Max OD 1.315"
Weight	0.8 lbs

## 4 Setup

The AS-TX sensor is factory calibrated and works out of the box. No additional programming is required.

### Wiring to the controller

1. Before wiring the sensor, make sure the controller is disconnected from live (AC) voltage.
2. Connect the probe wires to the controller according to the wiring diagram shown in Figure 4-1.

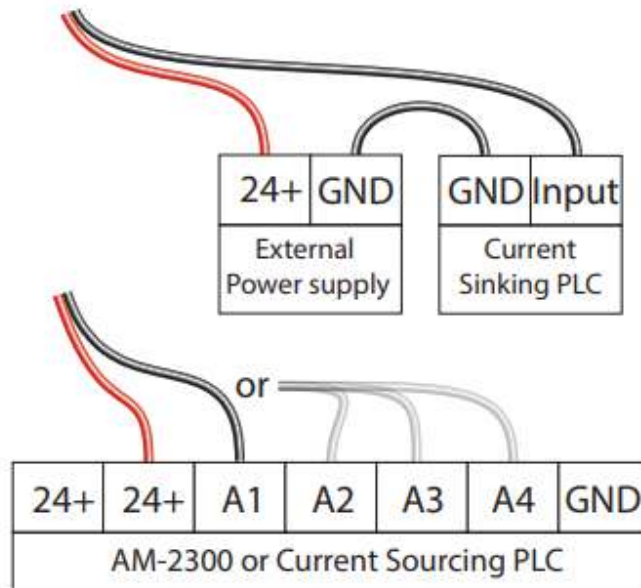

Figure 4-1 Wiring AS-TX to Current Sinking (top) or Current Sourcing Controllers (bottom).

To make wiring easy, each sensor comes with a printed wiring diagram located in the shipping box.

The AS-TX can work with the new AM-2252 controller or AM-2300 controller, as well as most third-party PLC controllers. Contact AquaMetrix to confirm compatibility.

## 5 Mounting

### General Installation Requirements

Check the probe to ensure that no air bubbles have formed on the electrodes during submersion.

### Submersion Mounting with the AM-ARM-5

The AS-TX is a fully submersible sensor. Although not required, submersion hardware to protect the cable from wear and tear is advisable. The AM-ARM-5 consists of a 4-foot long CPVC pipe with a 1" FNPT fitting on the front end on which to mount the probe and a strain relief on the back end. A wire bracket, constructed of thick aluminum wire, is used to secure the arm onto the edge of a tank or basin.

To mount the AS-TX on the AM-ARM-5:

1. Guide the probe cable from the 1" NPT fitting side from the front end of the submersion arm all the way through and back out the back.
2. Loosen the strain relief, thread the cable through, and tighten it.

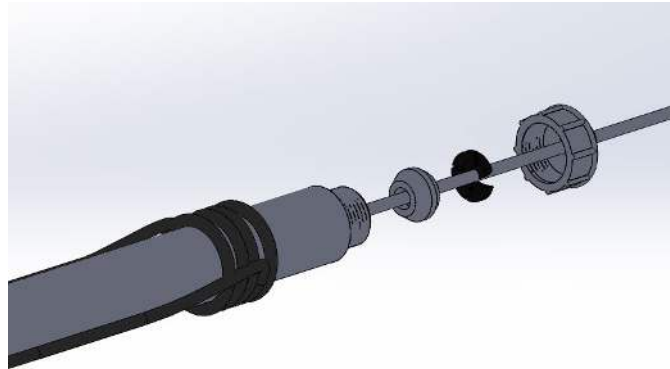

3. Slide the aluminum wire mounting bracket onto the probe.

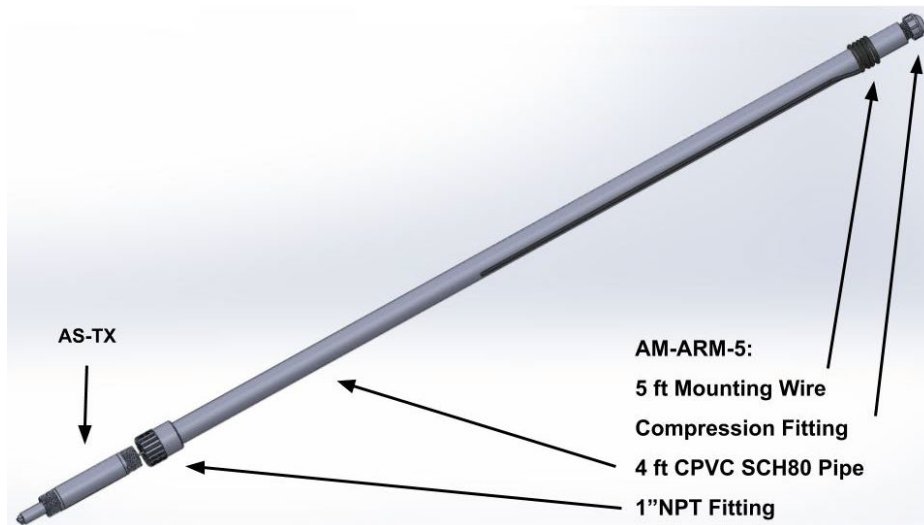

4. Apply sealant onto the back thread of the probe.
5. Screw the sensor (hand tight) into the 1" FNPT fitting on the front end.
6. Tighten the compression fitting (hand tight) on the back end.

### Inline Mounting with the AM-TEE-5

In-line measurements must be made with a 1" tee adapter. An off the shelf tee fitting will work. For mounting that allows quick removal of the probe without twisting the cable, consider the AM-TEE-5. This customized tee consists of a 1" FNPT compression fitting for the probe and a large lock nut for securing the probe.

To mount the AS-TX probe in the AM-TEE-5:

1. Insert split ring and nut over the sensor.

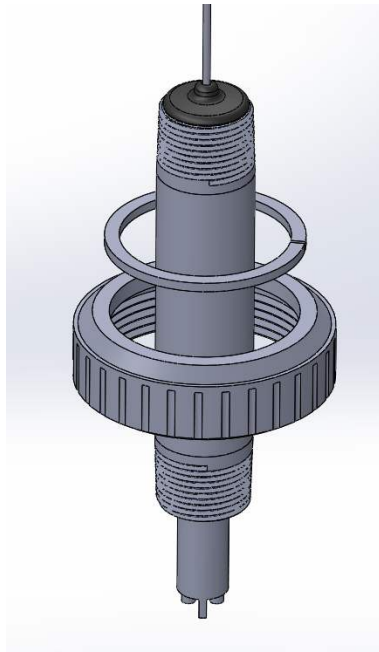

2. Screw the AS-TX into the 1" Insert bushing.

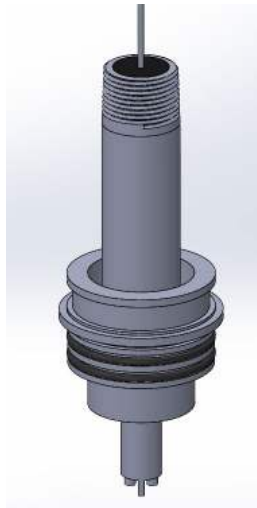

3. Slide the bushing assembly into the tee and screw on the compression nut. Install lock nut into a groove to keep the nut attached to the assembly.



## 6 Operation

### Maintenance

Periodic cleaning is required to remove any coating that has formed on the exterior of the electrodes. Ensure there is no rust forming as well.

### Digital Communication

The AS-TX comes ready to use out of the box. However, if desired, further calibration can be performed. To do so a computer, USB-RS485 Converter, and a power supply must be used.

### Wiring

To complete any of the following steps, the AS-TX sensor must be powered appropriately.

- a. Connect red and black wires to AM-2252 controller (red to 22, black to 21) or any 24VDC power supply (red – 24V+, Black – GND).

Connect RS-485 wires to USB converter: A- Yellow, B- Green, X-Blue (optional ground)

### PC configuration:

Download and install any terminal emulator that supports serial port (for example: Tera Term, HyperTerminal). We are going to use TeraTerm in the

Make sure the USB-RS485 ModBus Converter is plugged in

Open Tera Term

- d. Select Serial and identify correct USB port
- e. Type "Help" to display available commands

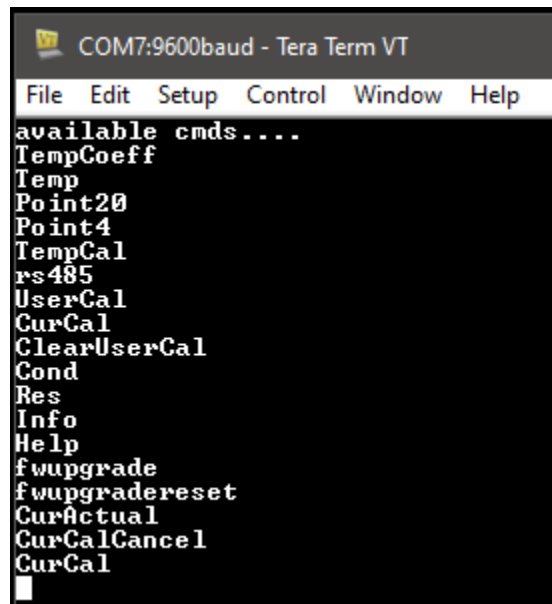

The image shows a screenshot of a Tera Term terminal window. The title bar reads "COM7:9600baud - Tera Term VT". The menu bar includes "File", "Edit", "Setup", "Control", "Window", and "Help". The terminal content displays a list of available commands:

```
available cmds....
TempCoeff
Temp
Point20
Point4
TempCal
rs485
UserCal
CurCal
ClearUserCal
Cond
Res
Info
Help
fwupgrade
fwupgradereset
CurActual
CurCalCancel
CurCal
```

## CLI Commands:

TempCoeff	Returns the current temperature coefficient.
TempCoeff:X	Sets the temperature coefficient to a user specified value between 0 and 10 %/°C with up to 2 decimal points. The default temperature coefficient is 2.
Temp	Returns the current temperature in °C
Point20	Point20 – returns conductivity value set for 20mA output
Point20:XXX	Sets conductivity for 20mA point (user can choose any value between 0 and 100,000 $\mu$ S/cm with up to 2 decimal points). Default is 10,000
Point4	Returns conductivity value for 4mA output
Point4:XXX	Sets conductivity for 4mA point (user can choose any value between 0 and 100,000 $\mu$ S/cm with up to 2 decimal points) Default is 0
TempCal	Begins a one-point temperature calibration
rs485	Checks rs485 functionality
UserCal:xxxxx	Begins a one-point conductivity calibration routine
ClearUserCal	Removes previously saved one-point user calibration “UserCal”
CurCal:4	Beings a two-point mA calibration routine. The mA output is set to 4.00mA
CurActual:XXX	Set the mA value to the value displayed by the reading device.
CurCal:20	Sets the mA output to 20 mA
CurCalCancel	Cancel the mA calibration at any point without saving and exit from the mA calibration routine.
Cond	Returns the current conductivity in $\mu$ s/cm.
Res	Returns the current resistivity in $\Omega$ .
Info	Return information about the transmitter: FW version, FW date, and all user-entered data.
Help	Return the list of availavle CLI commands
fwupgrade	Starts FW upgrade routine via RS485 without erasing the factory calibration
fwupgradereset	Starts FW upgrade routine via RS485 and reset all calibration. *Factory calibration will be lost, the transmitter requires recalibration

## Conductivity Range Selection

The AS-TX comes programmed using the following table based on the sensor's cell constant. If the range needs to be adjusted for whatever reason, follow the steps below. However, please note that if the range is increased, the accuracy of the sensor will decrease.

K-Factor	Point4	Point20
1	0	2,000
0.1	0	200
10	0	25,000

- a. Open Tera Term and plug in the flash drive adapter
- b. Type "Point20" and ensure the value matches the table above for the appropriate cell constant.

To change the Point20 value, type: "Point20:XXXX" where XXXX is the conductivity of the solution in  $\mu\text{S}/\text{cm}$  of the upper bound.

## 7 User Calibration

The AS-TX sensor comes with a factory calibration and is ready to use as is. The AS-TX has a mA output that is linear with default values of 4 mA = 0  $\mu\text{S}/\text{cm}$  and 20 mA = 2,000  $\mu\text{S}/\text{cm}$  (for cell constant  $k=1.0$ ). Since the conductivity is not linear by its nature, the linear 4-20mA output will not accurately represent the conductivity curve across the full range (see picture below). To improve the error at any specific point within the range, it is recommended that the user perform a user calibration at the point of interest. Doing so will modify the factory calibration, reducing the error at the user specified point to allow for a more accurate reading. However, the user should be aware that doing so will sacrifice the accuracy of the sensor at other points. The further away from the user specified point of interest, the greater the error. The graphs below illustrate the conductivity curves of the sensor before and after user calibration at various points. It is also possible for the user to increase the range using the RS485, but as the range is increased the accuracy of the sensor will decrease. Please note that the mA output is temperature compensated at 2% /  $^{\circ}\text{C}$  by default. This value can be changed by using the RS485 command.

User calibration can be done by one of the following methods:

- One-point calibration at the PLC (controller)
- Adjusting 20mA point at the PLC
- RS485 command

### One Point Calibration Using PLC

If the PLC allows calibration at any point, the user can use a calibration standard or a sample liquid with a known value to make that a calibration point.

### Calibrating By Adjusting PLC Range

In case where a PLC only allows to set 4mA and 20mA points and RS485 commands are not an option to perform calibration, the user can manipulate the 20mA point to achieve better accuracy in a specific point. As a reminder, the factory calibration provides the smallest error across the entire range, and it is most accurate around 1,200  $\mu\text{S}/\text{cm}$  (for a cell constant of  $k=1.0$ ). If the point of interest, for example, is 1,500  $\mu\text{S}/\text{cm}$ , the 20mA point should be set at 2,500  $\mu\text{S}/\text{cm}$ . On the other hand, if the point of interest is 500  $\mu\text{S}/\text{cm}$ , the 20mA point should be set to 1,500  $\mu\text{S}/\text{cm}$ . This is not as accurate as the other two methods and may take additional tuning of the 20mA value. As with the PC method, performing the PLC version of the user calibration will sacrifice the accuracy of the sensor at other points.

### One Point Calibration Using RS485

AS-TX sensors also have a digital interface that a user can access through a serial communication protocol RS485. The full list of commands can be found in section 6.2. One such command is “UserCal” that adjust the slope of the factory calibration to make the conductivity reading most accurate at the point of calibration.

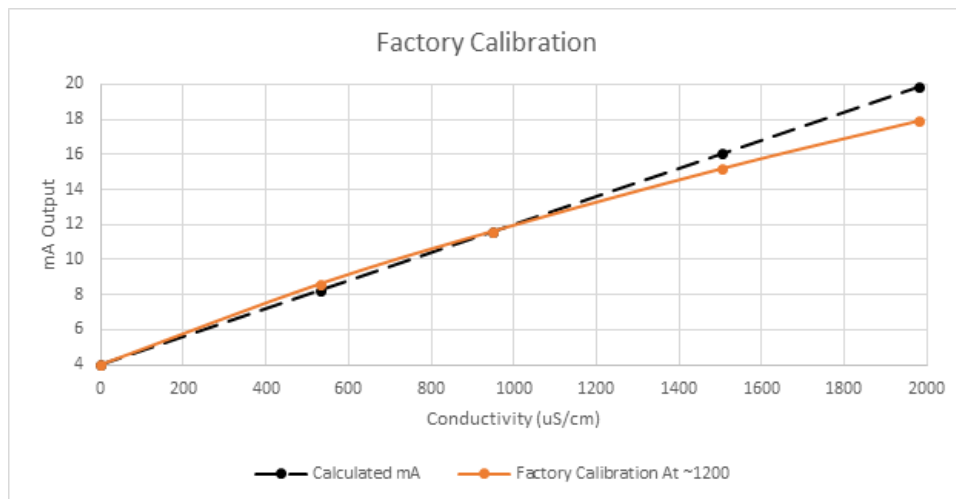

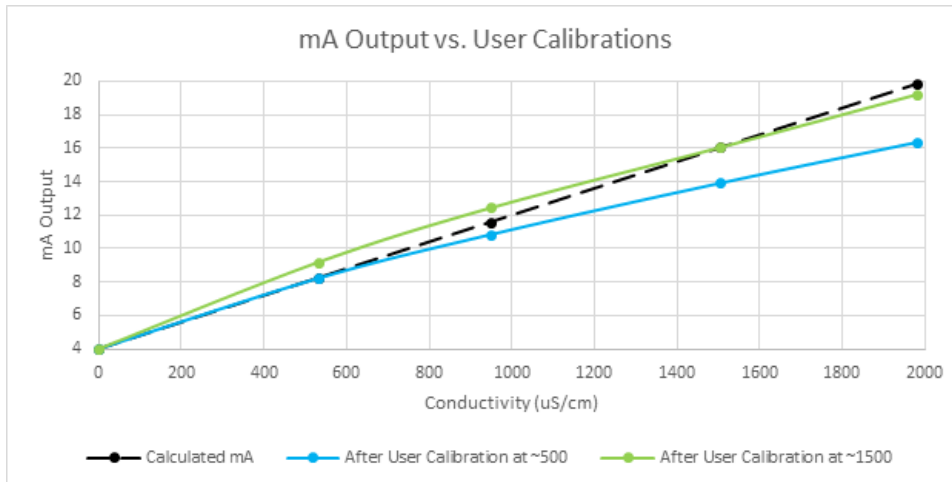

## Current Calibration

Using AM-2252 controller, navigate to Menu --> Diagnostic --> Sensors Output

b. In Tera Term window type "CurCal:4"

Read mA output from the AM-2252 screen

d. Type "CurActual:XXXX" where XXXX is the mA output value (Value should be close to 4.00 mA)

e. In Tera Term window press enter

Program will say proceed to next point (mA reading will not change yet)

Type "CurCal:20" (reading will change, value should be close to 20.00 mA)

h. Type "CurActual:XXXX" where XXXX is the mA output value

Current Calibration is complete. Slope and Offset are displayed.

Slope should be close to  $1 \pm 0.1$  offset should be close to  $0 \pm 1$ .

*\*CurCalCancel will cancel calibration at any point\**

## 8 In Field Upgrade:

- a. Load Tera Term
- b. Connect yellow, green, and blue wires to RS485-USB adapter
- c. Provide power to the sensor (red and black wires). Loop wiring is OK.
- d. Calibration data should appear. If not, power cycle by disconnecting and reconnecting either the red or black wires to the 2252 controller.
- b. Type “fwupgrade” and press enter.

A message should appear that reads: “AS\_TX BootLoader”. Three options will appear. Press 1  
You will be prompted to select an image file. To do so, navigate to File> Transfer> YMODEM> SEND.

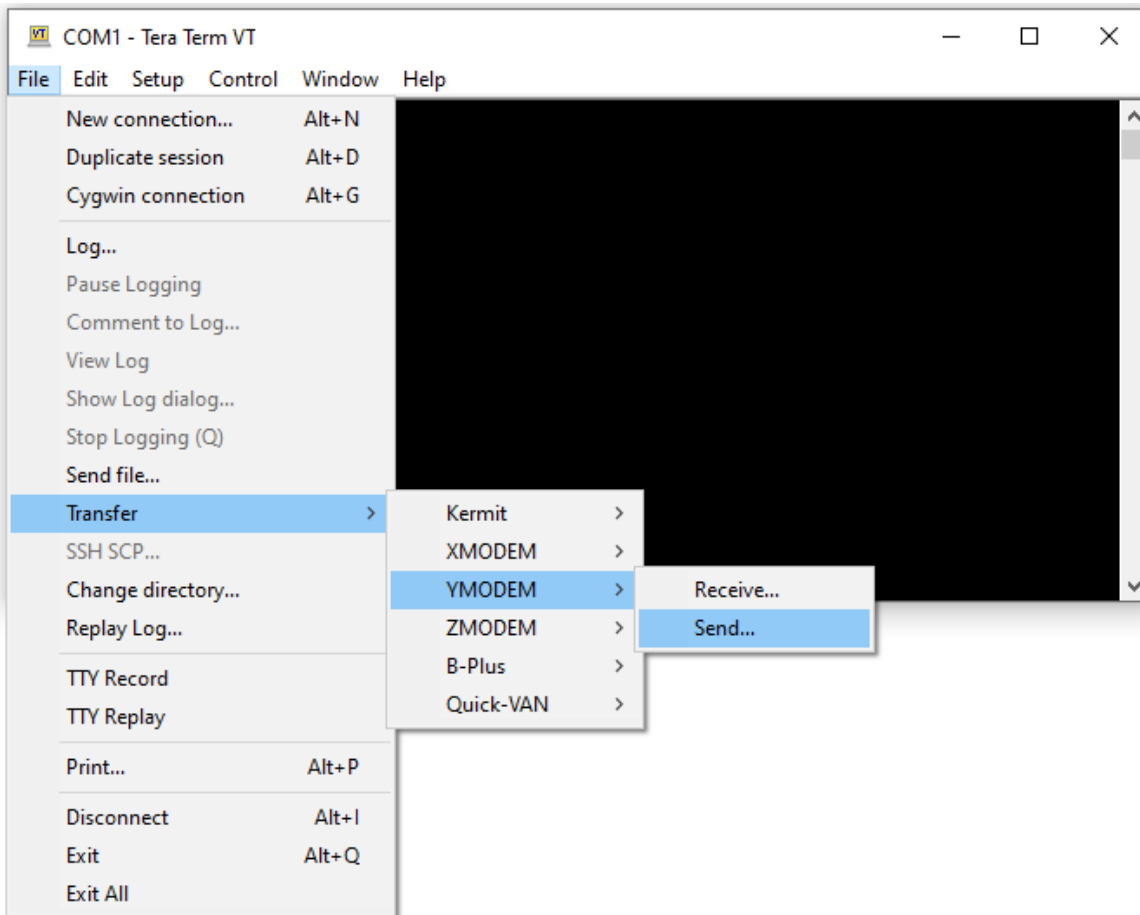

When the file selection window appears, navigate to the location of the new firmware. Select the most recent “XXXX.binary” file and press “Open”.

Once the file is selected, a loading screen will appear. It will take approximately 1-2 minutes to finish loading. Once this is completed, the window will close, and the upgrade will be finished.

## 9 Disposal

In accordance with local regulations, please dispose of this product at specified locations for electrical and electronic equipment. Please contact the local government/authority or party responsible from which you purchased this device. Should this device be passed on to other parties (for private or professional use), the content of this regulation must also be related.

## 10 Warranty

Water Analytics provides this material as-is and makes no warranties, express or implied, regarding its suitability for any specific purpose. Water Analytics shall not be held responsible for any errors or damages, whether incidental or consequential, arising from the use or performance of this material.

Under no circumstances shall Water Analytics be liable for any direct, incidental, or consequential damages resulting from the sale, manufacture, delivery, or use of any product.

Warranty information available on the website [www.AquaMetrix.com](http://www.AquaMetrix.com) or [www.wateranalytics.net](http://www.wateranalytics.net)

## 11 Contact

Please contact us at [support@wateranalytics.net](mailto:support@wateranalytics.net) or call us at 978-749-9949.

This manual contains confidential and copyrighted information owned by Water Analytics. The contents of this document may not be reproduced, photocopied, or translated into another language without the prior written consent of Water Analytics.



978-749-9949

[www.WaterAnalytics.net](http://www.WaterAnalytics.net)