



611 Series

Small Diameter Submersible
Pressure Transducers



Operating Instructions

Table Of Contents

| | |
|--|-----------|
| 1. General information | 4 |
| 2. Design and function | 5 |
| 3. Safety | 7 |
| 4. Transport, packaging and storage | 9 |
| 5. Usage, operation | 10 |
| 6. Faults | 15 |
| 7. Maintenance and cleaning | 17 |
| 8. Dismounting, return and disposal | 18 |
| 9. Specifications | 20 |

EU Declaration of Conformity can be found online at www.noshok.com.

1. General information

- The pressure transmitter described in the operating instructions has been designed and manufactured using state-of-the-art technology. All components are subject to stringent quality and environmental criteria during production. Our management systems are certified to ISO 9001:2015 and ISO 14001.
- These operating instructions contain important information on handling the instrument. Working safely requires that all safety instructions and work instructions are observed.
- Observe the relevant local accident prevention regulations and general safety regulations for the instrument's range of use.
- The operating instructions are part of the product and must be kept in the immediate vicinity of the instrument and readily accessible to skilled personnel at any time.
- Skilled personnel must have carefully read and understood the operating instructions prior to beginning any work.
- The manufacturer's liability is void in the case of any damage caused by using the product contrary to its intended use, non-compliance with these operating instructions, assignment of insufficiently qualified skilled personnel or unauthorized modifications to the instrument.
- The general terms and conditions contained in the sales documentation shall apply.
- Subject to technical modifications.
- For more information:
www.noshok.com
T: 440.243.0888
F: 440.243.3472
info@noshok.com

2. Design and function

2.1 Overview

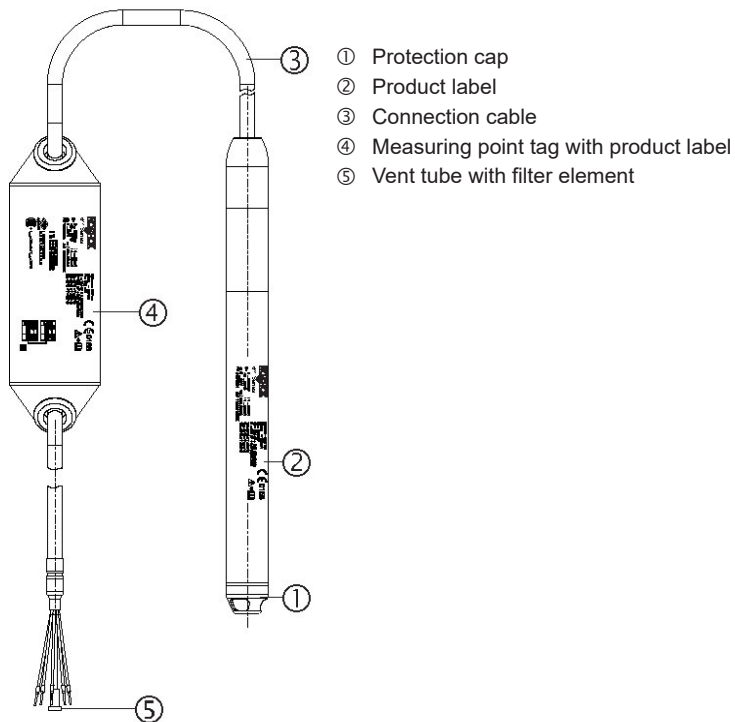

2. Design and function

2.2 Functional description

The prevailing hydrostatic pressure is measured at the sensor element through the deformation of a diaphragm. By supplying power, this deformation of the diaphragm is converted into an electrical signal. The output signal from the submersible pressure sensor is amplified and standardized. The output signal is proportional to the measured hydrostatic pressure.

HART® (option)

The instrument version with HART® can communicate with a controller (master).

Measuring range scaling (turndown)

The start and end of the measuring range can be set within the measuring range. Do not exceed a turndown of 10:1.

2.3 Scope of delivery

- Submersible pressure sensor
- Operating instructions
- Test report
- Measuring point tag for fixing to the cable end
- Further certificates (optional)

Cross-check scope of delivery with delivery note.

3. Safety

3.1 Explanation of symbols

**WARNING!**

... indicates a potentially dangerous situation that can result in serious injury or death, if not avoided.

**CAUTION!**

... indicates a potentially dangerous situation that can result in light injuries or damage to property or the environment, if not avoided.

**Information**

... points out useful tips, recommendations and information for efficient and trouble-free operation.

3.2 Intended use

The submersible pressure sensor is used to convert hydrostatic pressure into an electrical signal.

Only use the submersible pressure sensor in applications that lie within its technical performance limits (e.g. max. ambient temperature, material compatibility, ...).

→ For performance limits see chapter 9 "Specifications".

The instrument has been designed and built solely for the intended use described here, and may only be used accordingly.

The manufacturer shall not be liable for claims of any type based on operation contrary to the intended use.

3. Safety

3.3 Personnel qualification

Skilled personnel

Skilled personnel, authorized by the operator, are understood to be personnel who, based on their technical training, knowledge of measurement and control technology and on their experience and knowledge of country-specific regulations, current standards and directives, are capable of carrying out the work described and independently recognizing potential hazards.

3.4 Labeling, safety marks

Product label

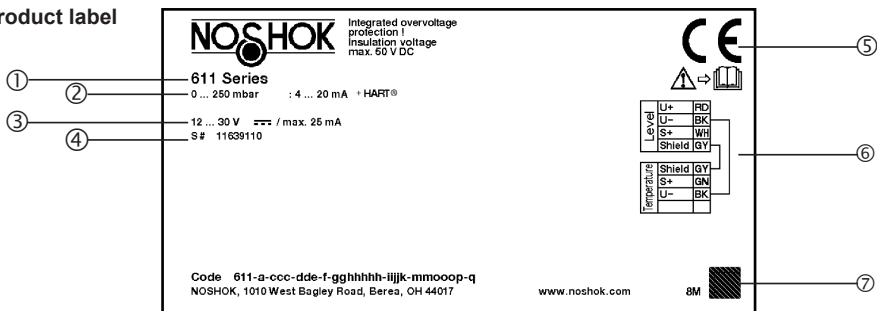

- ① Part number
- ② Measuring range / Output signal
- ③ Power supply / Total current consumption
- ④ Serial number
- ⑤ Approvals
- ⑥ Pin assignment
- ⑦ Date of manufacture



Before mounting and commissioning the instrument, ensure you read the operating instructions!



DC voltage

4. Transport, packaging and storage

4.1 Transport

Check the submersible pressure sensor for any damage that may have been caused by transport.

Obvious damage must be reported immediately.

Make sure that the connection contacts are not damaged.

4.2 Packaging and storage

Do not remove packaging until just before mounting.

Keep the packaging as it will provide optimum protection during transport (e.g. change in installation site, sending for repair).

Prior to storage, clean the submersible pressure sensor thoroughly (→ see chapter 7.3.2 “Cleaning”)

Permissible conditions at the place of storage:

- Storage temperature: -40 °F to -112 °F (-40 °C to 80 °C)
- Humidity: 45 to 75 % relative humidity (no condensation)

Avoid exposure to the following factors:

- Direct sunlight or proximity to hot objects
- Mechanical vibration, mechanical shock (putting it down hard)
- Soot, vapor, dust and corrosive gases
- Humid or wet environment
- Hazardous environments, flammable atmospheres

5. Usage, operation

5.1 Unpacking

When unpacking, do not use any sharp objects (e.g. cutter knives), as this may damage the cable.

Submersible pressure sensors with cable lengths >100 m are wound on cable drums and wrapped with foil. Unwind the foil manually. The end of the foil is marked with blue tape.

5.2 Suitability for the process conditions

All components of the instrument that are in contact with the process must be suitable for the process conditions that may exist. Included in this are particularly the process pressure, process temperature and also the chemical properties of the media. Prior to usage, the suitability of the instrument must be ensured (For specifications, see chapter 9 "Specifications" and the product label).

5.3 Requirements for mounting point

The mounting point must meet the following conditions:

- The diaphragm is protected from contact with abrasive media and against any impacts.
- The cable contains a capillary for the pressure compensation. Therefore, the cable must be connected in a dry space or a suitable terminal enclosure.
- Sufficient space for a safe electrical installation.
- Permissible ambient and medium temperatures remain within the performance limits. For performance limits see chapter 9 "Specifications".

5.4 Connecting the instrument

5.5 Requirements for voltage supply

For power supply see product label

5. Usage, operation

5.4.2 Requirements for electrical connection

Cable diameter matches the cable bushing of the terminal enclosure.

Cable gland and seals are correctly seated.

No humidity can ingress at the cable end.

5.4.3 Requirement for shielding and grounding

The submersible pressure sensor must be shielded and grounded in accordance with the grounding concept of the plant.

5.4.4 Fitting the measuring point tag

Before the submersible pressure sensor is wired, the measuring point tag must be attached to the cable. The measuring point tag acts to identify the submersed instrument and contains a copy of the product label.

1. Remove the packaging at the cable end



2. Thread the measuring point tag onto the cable.

The rubber stops at the measuring point tag protect the cable and must be undamaged and correct mounted. Position the measuring point tag so that, in the mounted state, it is easily reachable and protected against harsh environmental conditions.

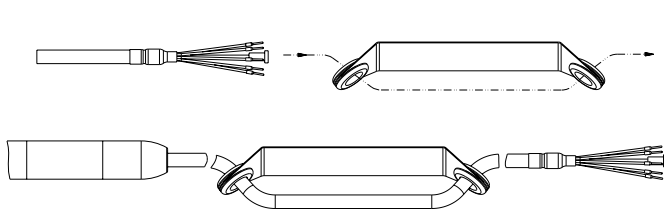

5. Usage, operation

5.4.5 Shortening the cable

The cable can be shortened as required. With submersible pressure sensors with voltage output, a shortening of the cable results in an offset error: $\leq 0.014 \% / \text{m}$ of shortened cable.

After the shortening, provide the wire ends with end splices and position the filter element on the vent tube.

5.4.6 Connecting the instrument to the electric system

- ▶ Connect the cables to the terminals.
- ▶ For voltage outputs, the load must be specified so that the output current does not exceed 1 mA.

Load

Current output: $\leq (U_+ - (U_{+\text{min}} - 0.5 \text{ V})) / 0.023 \text{ A}$

Voltage output: $\leq 1 \text{ mA}$

Additional load of the cable:

$\leq \text{cable length in m} \times 0.084 \Omega$

Pin assignment

4 ... 20 mA, 4 ... 20 mA + HART® (2-wire)

| | |
|--------|------------|
| U+ | brown (BN) |
| U- | blue (BU) |
| Shield | grey (GY) |

2 x 4 ... 20 mA (2 x 2-wire, galvanically isolated)

| | |
|-------------------------|------------|
| U+ (pressure sensor) | brown (BN) |
| U- (pressure sensor) | blue (BU) |
| U+ (temperature sensor) | green (GN) |
| U- (temperature sensor) | white (WH) |
| Shield | grey (GY) |

5. Usage, operation

DC 0.1 ... 2.5 V (3-wire, low power)

| | |
|--------|------------|
| U+ | brown (BN) |
| U- | blue (BU) |
| S+ | black (BK) |
| Shield | grey (GY) |

2 x DC 0.1 ... 2.5 V (3-wire, low power)

| | |
|-------------------------|------------|
| U+ | brown (BN) |
| U- | blue (BU) |
| S+ (pressure sensor) | black (BK) |
| S+ (temperature sensor) | green (GN) |
| Shield | grey (GY) |

Legend

- U+ Positive power supply terminal
- U- Negative power supply terminal
- S+ Analog output

5.4.7 Mounting the instrument

Prior to usage, the submersible pressure sensor must be subjected to a visual inspection.

- Leaking fluid is indicative of damage.
- Only use the submersible pressure sensor if it is in perfect condition with respect to safety.

The protection cap protects the internal diaphragm from damage during transport and during the lowering of the probe. With viscous or contaminated media, the protection cap can be removed in order to ensure trouble-free operation.

When laying the cable, a minimum bending radius of 120 mm must be ensured.

5. Usage, operation

5.5 Configuring via HART® interface

The HART® modem with RS232, USB or Bluetooth interface (→ see Accessories) enables the connection of communicating instruments to the respective interface of a PC. To parameterize these instruments, operating software with COMM DTM HART and Device DTM Generic HART (e.g. PACTware®) is needed.



The operating software and the required DTMs are available for download at www.noshok.com.

Connecting submersible pressure sensor to PC (HART®)

Any work should only be carried out in a non-hazardous area.

1. Connect HART® modem to submersible pressure sensor.
2. Connect HART® modem to PC or notebook.

With repeater power supplies with integrated HART resistances (internal resistance approx. 250 Ω), no additional external resistance is necessary.

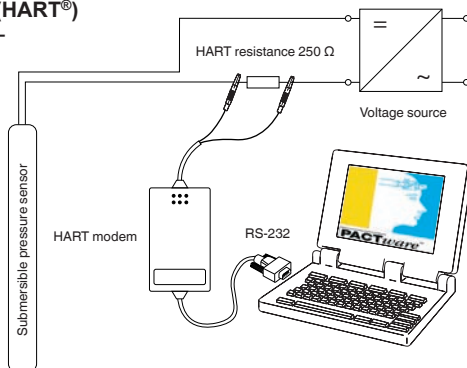

For further information see the operating instructions of the respective display and control unit.

6. Faults



CAUTION!

Physical injuries and damage to property and the environment

If faults cannot be eliminated by means of the listed measures, the submersible pressure sensor must be taken out of operation immediately.

- ▶ Ensure that pressure or signal is no longer present and protect against accidental commissioning.
- ▶ Contact the manufacturer.
- ▶ If a return is needed, please follow the instructions given in chapter 8.2 "Return".



WARNING!

Physical injuries and damage to property and the environment caused by hazardous media

Upon contact with hazardous media (e.g. oxygen, acetylene, flammable or toxic substances), harmful media (e.g. corrosive, toxic, carcinogenic, radioactive), and also with refrigeration plants and compressors, there is a danger of physical injuries and damage to property and the environment.

- ▶ Should a failure occur, aggressive media with extremely high temperature and under high pressure or vacuum may be present at the instrument.
- ▶ For these media, in addition to all standard regulations, the appropriate existing codes or regulations must also be followed.
- ▶ Wear the required protective equipment.



For contact details see chapter 1 "General information" or the back page of the operating instructions

In the event of any faults, first check whether the submersible pressure sensor is mounted correctly, mechanically and electrically.

6. Faults

| Faults | Causes | Measures |
|-------------------------------|--|--|
| No output signal | Cable break | Check the continuity |
| | Incorrect power supply connected | Rectify the power supply |
| Deviating zero point signal | Overpressure limit exceeded | Observe the permissible overpressure limit |
| | Too high/low working temperature | Observe the permissible temperatures |
| | Diaphragm damage | Replace instrument; if it fails repeatedly, contact the manufacturer |
| Zero point varies/inaccurate | Moisture has entered at the cable end | Fit the cable correctly |
| | Cable damaged | Replace instrument; if it fails repeatedly, contact the manufacturer |
| Signal span varies/inaccurate | Too high/low working temperature | Observe the permissible temperatures |
| Signal span drops/too small | Mechanical overload caused by overpressure | Replace instrument; if it fails repeatedly, contact the manufacturer |
| | Diaphragm damage | Replace instrument; if it fails repeatedly, contact the manufacturer |
| Signal span drops | Moisture has entered at the cable end | Fit the cable correctly |
| | Cable damaged | Replace instrument; if it fails repeatedly, contact the manufacturer |

7. Maintenance and cleaning

7.1 Maintenance

When used in strongly contaminated and adhesive media, the pressure port of the submersible pressure sensor has to be cleaned regularly. The cleaning interval is dependent upon the respective application. The checking and cleaning of the pressure port should thus be added to the maintenance plan. Since the cleaning intervals are dependent on the operating conditions, no universal time periods can be specified.

Repairs must only be carried out by the manufacturer.

7.2 Cleaning



WARNING!

Physical injuries and damage to property and the environment through residual media

Residual media at the dismantled instrument can result in a risk to persons, the environment and equipment.

- ▶ With hazardous substances, observe the material safety data sheet for the corresponding medium.
- ▶ Wear the requisite protective equipment.



CAUTION!

Unsuitable cleaning agents

Cleaning with unsuitable cleaning agents may damage the instrument and the product label.

- ▶ Do not use any aggressive cleaning agents.
- ▶ Do not use any hard or pointed objects.
- ▶ Do not use any abrasive cloths or sponges.

Recommended cleaning agents

- Water
- Conventional dishwashing detergent

Cleaning the instrument

1. Disconnect the submersible pressure sensor from the mains.
2. Wipe the instrument surface using a soft, damp cloth.

8. Dismounting, return and disposal

8.1 Dismounting



WARNING!

Physical injuries and damage to property and the environment caused by hazardous media

Upon contact with hazardous media (e.g. oxygen, acetylene, flammable or toxic substances), harmful media (e.g. corrosive, toxic, carcinogenic, radioactive), and also with refrigeration plants and compressors, there is a danger of physical injuries and damage to property and the environment.

- ▶ Should a failure occur, aggressive media with extremely high temperature and under high pressure or vacuum may be present at the instrument.
- ▶ Wear the required protective equipment.

Dismounting the instrument

1. Disconnect the submersible pressure sensor from the mains.
2. Disconnect the electrical connection.
3. Withdraw the submersible pressure sensor from the medium.

8.2 Return

Strictly observe the following when shipping the instrument:

All instruments delivered to NOSHOK must be free from any kind of hazardous substances (acids, bases, solutions, etc.) and must therefore be cleaned before being returned.



WARNING!

Physical injuries and damage to property and the environment through residual media

Residual media in the dismantled instrument can result in a risk to persons, the environment and equipment.

- ▶ With hazardous substances, include the material safety data sheet for the corresponding medium.
- ▶ Clean the instrument, see chapter 7.2 "Cleaning".

8. Dismounting, return and disposal

When returning the instrument, use the original packaging or a suitable transport packaging.



Information on returns (RMA Requests) can be found under the heading “Contact Us” on our website at www.noshok.com.

8.3 Disposal

Incorrect disposal can put the environment at risk. Dispose of instrument components and packaging materials in an environmentally compatible way and in accordance with the country-specific waste disposal regulations.

9. Specifications

Measuring ranges (gauge pressure), 611 Series

| | | | | | | | |
|-------------------|-----------|------------|------------|-----------|-----------|-----------|-----------|
| bar | 0 ... 0.1 | 0 ... 0.16 | 0 ... 0.25 | 0 ... 0.4 | 0 ... 0.6 | 0 ... 1 | 0 ... 1.6 |
| | 0 ... 2.5 | 0 ... 4 | 0 ... 6 | | | | |
| inWC | 0 ... 50 | 0 ... 100 | 0 ... 150 | 0 ... 250 | | | |
| psi | 0 ... 5 | 0 ... 10 | 0 ... 15 | 0 ... 25 | 0 ... 50 | 0 ... 100 | |
| mH ₂ O | 0 ... 1 | 0 ... 1.6 | 0 ... 2.5 | 0 ... 4 | 0 ... 6 | 0 ... 10 | 0 ... 16 |
| | 0 ... 25 | 0 ... 40 | 0 ... 60 | | | | |

Measuring ranges (absolute pressure), 611 Series

| | | | | | | | |
|-----|-----------|-----------|-----------|---------|--|--|--|
| bar | 0 ... 1.6 | 0 ... 2.5 | 0 ... 4 | 0 ... 6 | | | |
| psi | 0 ... 25 | 0 ... 50 | 0 ... 100 | | | | |

| Specifications | 611 Series |
|----------------------------------|---|
| Overpressure limit | ≥ 3 times |
| Temperature measurement (option) | see product label |
| Output signal | see product label |
| Load | Current output: $\leq (U_+ - (U_{+min} - 0.5 \text{ V})) / 0.023 \text{ A}$ Voltage output: $\leq 1 \text{ mA}$ Additional load of the cable: $\leq \text{cable length in m} \times 0.084 \text{ } \Omega$ |
| Power supply | see product label |
| Current consumption | Current output: max. 25 mA per output Voltage output: max. 5 mA |

9. Specifications

| Specifications | 611 Series |
|--|---|
| Accuracy (pressure sensor) (at reference conditions) | $\leq \pm 1 \%$ of span $\leq \pm 0.5 \%$ of span (option) |
| Accuracy (temperature sensor) | $\pm 1.8 \text{ K}$ (-10 °C to 80 °C) |
| Accuracy after turndown 5:1 via HART® | $\leq \pm 1.25 \%$ of scaled span $\leq \pm 0.75 \%$ of scaled span (option) |
| Non-linearity (per IEC 61298-2) | $\leq \pm 0.5 \%$ of span BFSL $\leq \pm 0.25 \%$ of span BFSL (option) |
| Non-repeatability | $\leq 0.1 \%$ of span $\leq 0.2 \%$ of span (with voltage output and cable length >100 m) |
| Temperature error | see table "Temperature error" |
| Long-term stability (per DIN 16086:2006-01) | Measuring range > 0 ... 0.1 bar: $\leq \pm 0.1 \%$ of span/year Measuring range ≤ 0 ... 0.1 bar: $\leq \pm 0.2 \%$ of span/year |
| Reference conditions | |
| <ul style="list-style-type: none"> ■ Ambient temperature | 59°F - 77 °F (15 °C - 5 °C) |
| <ul style="list-style-type: none"> ■ Atmospheric pressure | 860 ... 1,060 mbar (86 ... 106 kPa /12.5 ... 15.4 psig) |
| <ul style="list-style-type: none"> ■ Humidity | 45 ... 75 % r. h. |
| <ul style="list-style-type: none"> ■ Power supply | DC 24 V with current output DC 5 V with voltage output |
| <ul style="list-style-type: none"> ■ Mounting position | Calibrated in vertical mounting position with protection cap thread facing downwards. |
| Ingress protection | IP68 |
| Insulation voltage | DC 850 V Option of increased overvoltage protection for lightning strikes: DC 50 V |
| Resistance to overvoltage | DC 40 V |
| Reverse polarity protection | U+ vs. U- |
| Short-circuit resistance | S+ vs. U- |

9. Specifications

| Specifications | 611 Series |
|---------------------------------|---|
| Immersion depth | max. 100 m |
| Max. tensile force of the cable | 1,000 N |
| Weight | Submersible pressure sensor: approx. 300 g Cable: approx. 80 g/m Additional weight: 300 g |
| Permissible temperature ranges | Medium: -40 °F - 176 °F (-40 °C - +80 °C) Ambient: -40 °F - 176 °F (-40 °C - +80 °C) Storage: -22 °F - 176 °F (-30 °C - +80 °C) |
| Switch-on time | Output signals without HART®: ≤ 150 ms Output signals with HART®: ≤ 250 ms |
| Settling time | Output signals without HART®: ≤ 100 ms Output signals with HART®: ≤ 250 ms |
| Wetted parts | |
| ■ Case | 316L (high-resistance option: 318LN) |
| ■ Sensor | 316L (high-resistance option: Hastelloy C276) |
| ■ Cable | PUR (high-resistance option: FEP) |
| ■ Sealing | FKM |
| ■ Protection cap | PVDF |
| CE conformity | EMC directive, emission (group 1, class B) and interference immunity (industrial application) |

9. Specifications

Dimensions in mm [in]

Cable outlet without conduit

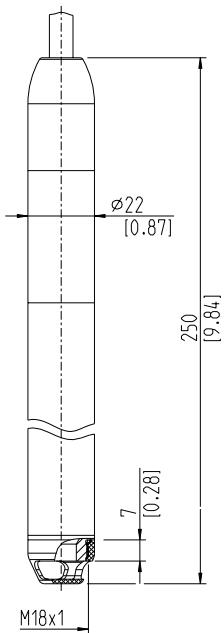

Cable outlet with conduit

