



# PDFM 6.1

**Instruction Manual**



Note: This page has been left blank intentionally.

**CONTENTS**

CARRY CASE.....	4
INTERNAL BATTERY.....	5
CHARGER.....	5
TRANSDUCER CONNECTIONS.....	6
USB-C CONNECTIONS (CHARGER, MODULES) .....	6
TRANSDUCER & CABLE .....	7
KEYPAD.....	7
POWER ON/OFF & CHARGING .....	9
MENU STRUCTURE .....	10
MESSAGES.....	12
STATUS.....	12
PASSWORD.....	13
MAIN MENU.....	14
UNITS/MODE .....	14
CALIBRATION.....	16
DATA LOGGING .....	17
RETRIEVING LOG FILE.....	17
SPECIAL FUNCTIONS .....	18
CONFIGURATION.....	19
SENSOR MOUNTING LOCATION.....	20
SENSOR MOUNTING .....	21
COMMON QUESTIONS AND ANSWERS .....	24
APPLICATIONS HOTLINE.....	26
PRODUCT RETURN PROCEDURE .....	26
APPENDIX A - CONVERSION TABLE.....	30
APPENDIX B - PIPE CHARTS.....	31

**IMPORTANT NOTE:** *This instrument is manufactured and calibrated to meet product specifications. Please read this manual carefully before installation and operation. Any unauthorized repairs or modifications may result in a suspension of the warranty.*

*If this product is not used as specified by the manufacturer, protection may be impaired.*

**CARRY CASE**

The PDFM 6.1 is packaged in an orange IP67 carry case with protective molded foam. The picture below shows how the various components included with the PDFM 6.1 are populated into the molds:

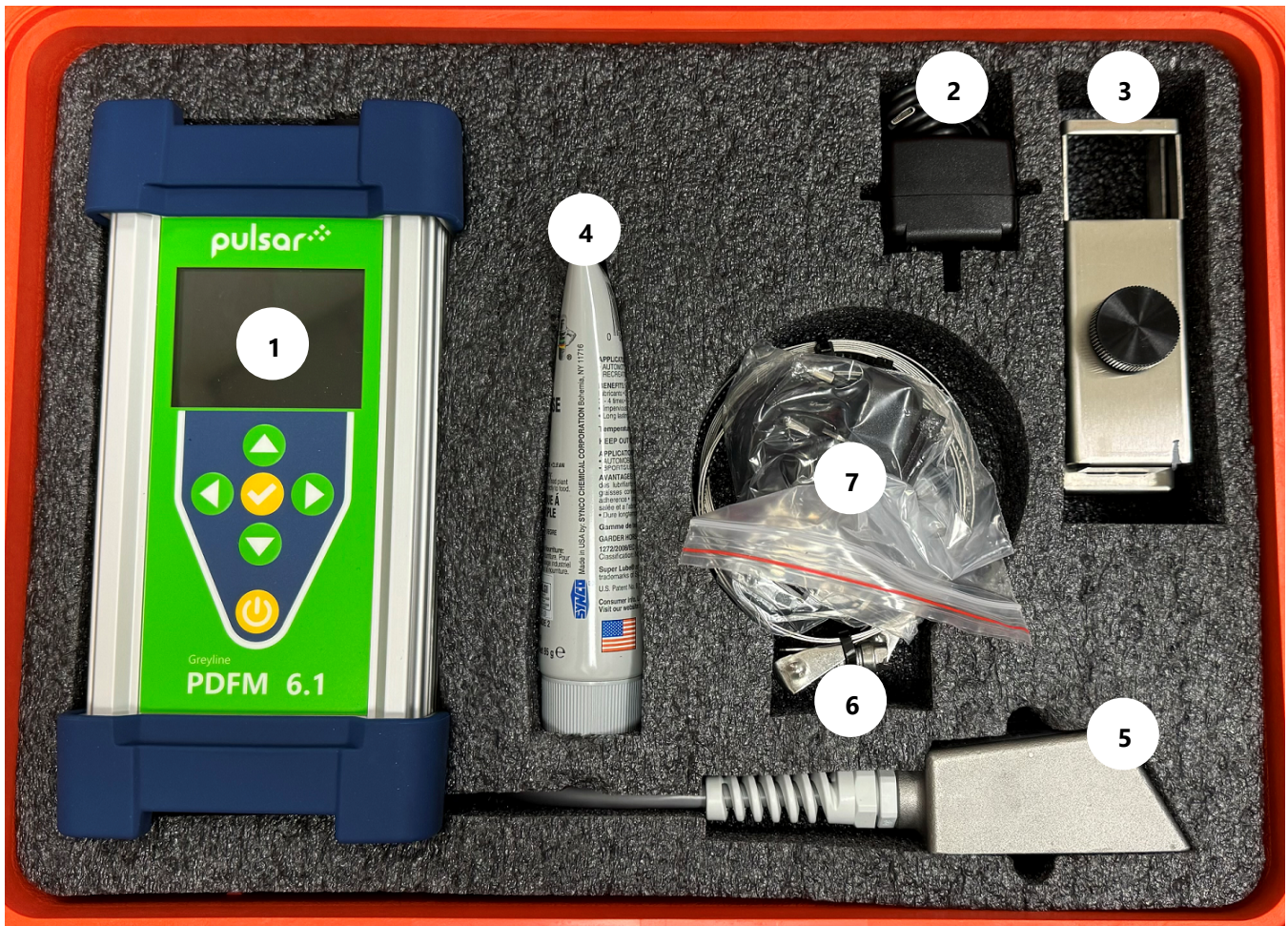

**Legend**

Position	Description	Position	Description
1	PDFM Electronics	6	QTY 2, Hose Clamps 0.05 to 8.56 in OD 1.75 to 22 in OD Can be combined for up to 30 in OD
1 (Underneath)	Transducer cable	7	International Plug Adapters for USB-C Wall Charger
2	USB-C Wall Charger		
3	SE14-A2 Transducer Mounting Bracket		
4	Coupling Compound, 3 oz Super Lube®		
5	SE14-A2 Transducer w/ Cable		

## INTERNAL BATTERY

**WARNING: The PDFM 6.1 includes a lithium-ion battery. For your safety, operate only within the specifications put forth by Pulsar.**

- A built-in rechargeable lithium-ion battery supplies power for approximately 15 hours of continuous operation when fully charged.
- When you first use the PDFM 6.1, the battery fuel gauge system needs a couple of charge and discharge cycles to full acclimate. The meter may reach 100% charge or 0% discharge faster than anticipated until the acclimation is complete.
- State of charge is shown when the meter is ON, or when the meter is in STANDBY mode while connected to a charger only. The rate of charge is the highest only when ON or in STANDBY mode as well. Therefore, it is recommended that the meter is only charged while in one of these two modes.
- When the charge of the battery reaches 100%, the meter will reduce the charge current to avoid damaging or degrading the battery. In this state, there will be a very slow discharge. When the meter reaches 98% charge while in this state, the current will go back up to charging levels until a 100% charge is reached. This cycle will repeat until the charger is disconnected or the meter powered OFF.
- When the battery reaches 5%, a pop-up message will appear stating that the charge is low, and that the meter will automatically shut-down at 0%. To clear this message permanently, connect the charger. To temporarily clear the message, press any button on the meter.
- A full charge from empty requires approximately 6 hours of charging using the included 3 Amp (15 Watt) charger.

## CHARGER

Included with the PDFM 6.1 package is a mains-powered to USB-C charging adapter rated for 5 Volt & 3 Amp (15 Watt). The power outlet connection type can be changed via the included modular plates.

For best results, use the included charger. However, a third-party USB-C cable connected to a third-party charger or battery bank will suffice. Charge speed may be slower than the included charger if the output is not capable of delivering 2 Amps at 5 Volts (10 Watts).

### **TRANSDUCER CONNECTIONS**

The transducer cable is connected via the IP67 socket on the top of the PDFM 6.1:

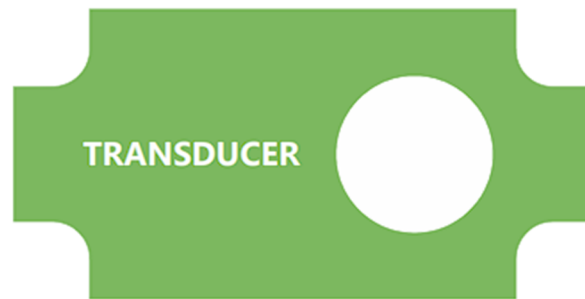

### **USB-C CONNECTIONS (CHARGER, MODULES)**



USB-C is a USB connector system with a rotationally symmetrical connector. Devices connected to USB-C may be hosts or peripherals. The PDFM 6.1 is able to make itself both, referred to as "Dual-Role-Data (DRD)" or "USB On-The-Go".

When connected to a USB power delivery system, such as the included wall charger, a laptop port, an automobile port, or a portable USB power delivery device, the PDFM 6.1 becomes the peripheral and will charge.

When connected to a USB storage device, such as the included flash drive, the PDFM 6.1 becomes the host and will transfer data to the storage device.

The design of the PDFM 6.1 allows for future deployment of "modules" which will be able to plug in to the USB-C port on the PDFM, and expand its capability.

## TRANSDUCER & CABLE

The PDFM 6.1 is equipped with a single PSE4-A2 transducer which has an integral 12 foot (3.4 meter) cable ready for connection to the PDFM 6.1 socket. The PDFM 6.1 will be “wet” calibrated against a secondary standard for every order. The suitable pipe size range for the PDFM 6.1 is 0.5 to 180 inches (13mm to 4.6m), nominal.

## KEYPAD

Keypad layout and functionality is as shown and described below:

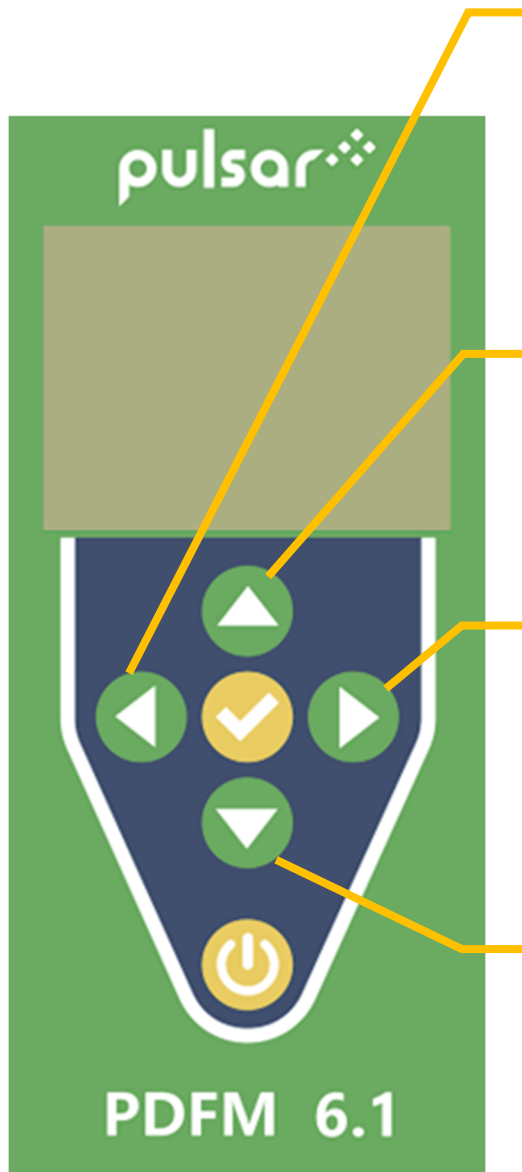

### LEFT Arrow:

- From Main screen – Navigate to 24 Hr Log page
- In programming menus – navigate out of the Main Menu or sub-menu
- In pop-out menus – cancel the selection of a parameter. For numerical entries – moves the cursor left, unless on the left-most number, which will then cancel the numerical entry.

### UP Arrow:

- From Main screen – Navigate to Messages page
- In programming menus – navigate up in the menus
- In pop-out menus – change the selection or numeric entry

### RIGHT Arrow:

- From Main screen – Navigate to Main Menu programming page or Passcode entry
- In programming menus – navigate into the selected sub-menus, or bring up a pop-out menu for a parameter
- In pop-out menus – change the selected number in a numerical entry

### DOWN Arrow:

- From Main screen – Navigate to Status page
- In programming menus – navigate down in the menus
- In pop-out menus – change the selection or numeric entry

**KEYPAD (CONT.)**

Keypad layout and functionality continues as shown and described below:

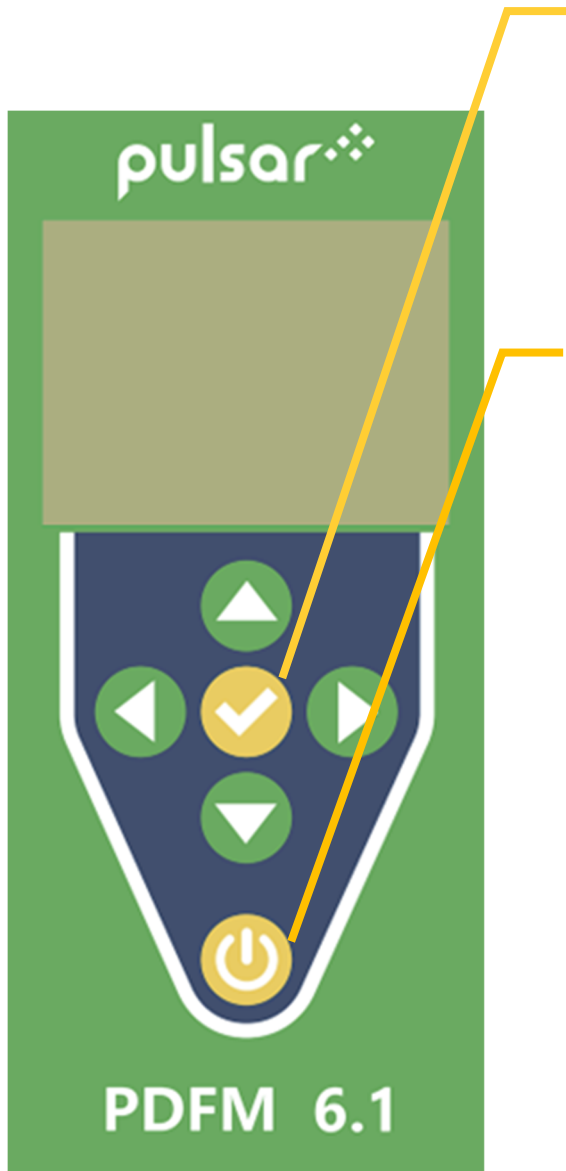

**CHECK Button:**

- From Main screen – not applicable
- In programming menus – will move the cursor back one level. Example: if in the Units/Mode sub menu, CHECK will move back to Main Menu.
- In pop-out menus – confirms the selection of a parameter or numerical entry.

**POWER Button:**

- From Main screen – Press for the Power Mode selection pop-out.
- In programming menus – exits to Main screen
- In pop-out menus – exits to Main screen
- From Sleep/Standby Logging mode – Press for the WakeUp selection pop-out.

## POWER ON/OFF & CHARGING

Press and hold the POWER button for 3-5 seconds to turn the meter on. When powering on, the meter will display a boot-up screen with the Pulsar Measurement logo:

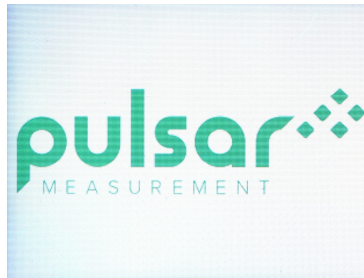

When powering off, press the POWER button and the meter will display a pop-up message that asks for input on which power mode to use. Select Cancel to return to normal operation, select Sleep Logging (only appears when the Log In Standby parameter is ON in the Data Logging menu) to put the meter in a low power (standby) state where it will "wake up" to make a measurement at the Interval defined in the Data Logging menu, or select Power Off to turn the PDFM 6.1 off:

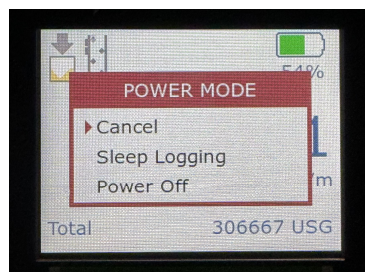

**IMPORTANT: Charging should only be done while the meter is ON or in Sleep/Standby.**

This allows the charging regulation circuit to charge at the optimum rate, ensuring a fast and efficient charge, and maximizing battery life. The meter will automatically slow the charging rate when maximum charge is approached. Once the battery charge drains slightly, to 97% with the charger still connected, the meter will automatically turn on the charger current again to return to 100%.

Third-party USB-C charging devices or battery banks are acceptable to use. Charge speed may be slower than the included charger if the output is not capable of delivering 2 Amps at 5 Volts (10 Watts).

**MENU STRUCTURE**

The structure of the menu pages on the PDFM 6.1 is as follows. Using the buttons as shown below will navigate between the different menus:



1 – Inserting a USB drive while on this page will download the 24 hr log data to the USB in .csv format

2 – Will not appear if the Set Password parameter in the Special Functions menu is set to 0000

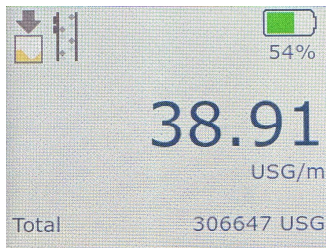
**MAIN DISPLAY**

The main display's top row shows icons for the status of the data logger, signal quality, charging status, battery fuel gauge percentage, and data logging download status when a USB-C drive is inserted while on this page.

In the middle row of the main display you will see the current numeric value of either the flow rate or velocity, and the associated units of measurement as selected in the Units/Mode menu.

The bottom row shows the total volume accumulated over time, with associated units of measurement as selected in the Units/Mode menu.

**ICONS:**

Data Logger LOGGING



Data Logger STOPPED



Signal Strength > 0%

Animation shows particles moving in the pipe (for Doppler effect to function)



Signal Strength = 0%

The screen will also display a "LOW SIGNAL" message



Data Logger downloading (animation shows USB filling)



Data Logger download complete



Battery charging

### MESSAGES

Messages	
Data Log	Logging
Log Used	0.00025%
Battery Level	54%
Charger	Off
Sensor	Good

Pressing the UP arrow button from the Main Display will take you to the Messages page. This page shows the status of the Data Log in plain text, percentage of the Log Used, the Battery Level fuel gauge in plain text, Charger status, and Sensor status in plain text. Press DOWN, CHECK, or POWER to return to the Main Display.

**Data Log** – Status can be Stopped (not logging) or Logging. Matches state of the icon on the Main Display.

**Log Used** – Percentage used of the internal storage for the data log. The PDFM 6.1 has storage for approximately 12.5 million logs, or almost 4 years at the fastest logging interval of 10 seconds/log.

**Battery Level** – Percentage remaining in the fuel gauge. Meter will automatically shut-down at 0% with no charger connected.

**Charger** – Shows either Charging or Off depending if charger is connected and charging (Charging) or meter is not charging with/without charger connected (Off). The meter can be not charging with charger connected when the battery reaches 100% with the charger connected.

**Sensor** – Shows Low Signal, Good, or SystemFault. Low Signal indicates that the sensor connection is good, but there is no signal (no detectable movement of entrained air or solids in the line, or empty pipe). SystemFault indicates a hardware issue, and if you see this message please contact Pulsar Measurement for support.

### STATUS

Status	
Velocity	0.99 ft/s
Flow	38.91 USG/m
Min Flow	4.00 USG/m
Signal	24%
Signal Cutoff	10%

Pressing DOWN from the Main Display will take you to the Status page. This page shows the status of the measurement itself, Flow Velocity currently measured, Flow Rate currently measured, Min Flow (read-only) as set in the Calibration menu, Signal strength, Exp. SOS (Expected fluid Speed Of Sound), and Meas. SOS (Measured fluid Speed Of Sound). Press UP, CHECK, or POWER to return to the Main Display.

**Velocity** – Shows the measured velocity in either ft/s or m/s, as set in the Units/Mode menu.

**Flow** – Shows the measured flow rate in units set in the Units/Mode menu.

**Min Flow** – Shows the minimum flow rate as set in the Calibration menu. Any flow rate below the Min Flow results in the flow rate displaying as 0.0

**Signal** – Displays the strength of the received Doppler signal on a 0-100% scale. There are a few factors which determine the signal strength, such as the velocity of the fluid, the prevalence of a similar Doppler shift from the moving particles/air in the fluid, and the strength of the received Doppler signal. Acceptable signal strengths have a wide range. Anywhere above the default cutoff of 10% should be considered usable.

**STATUS (CONT.)**

Status	
Velocity	0.99 ft/s
Flow	38.91 USG/m
Min Flow	4.00 USG/m
Signal	24%
Signal Cutoff	10%

**Signal Cutoff** - Displays the cutoff where any Signal less than Signal Cutoff will cause the Flow reading to measure 0.0. This value is configurable in the Calibration menu.

**24 HR LOG**

24 hr log	
Date	*Feb 09/2024
Total	381 USG
Average	3.52 USG/m
Maximum	60.48 USG/m
Max Time	09:19:46
Minimum	0.00 USG/m
Min Time	00:00:00

Pressing LEFT from the Main Display will take you to the 24 HR LOG page. This page shows a summary view of the flow, starting with today's data. Pressing the DOWN or UP arrows will scroll to previous day's data. Up to 365 days will be stored. Newer data will overwrite the oldest, automatically, once the 365 day limit is reached. Press RIGHT, CHECK, or POWER to return to the Main Display.

**IMPORTANT:** Inserting a USB-C drive into the meter while on this screen will transfer the 24 hr log data to the drive in .csv format. The Date, Total, Average, Maximum, Max Time, Minimum, and Min Time for the last 365 days are transferred.

**PASSWORD**

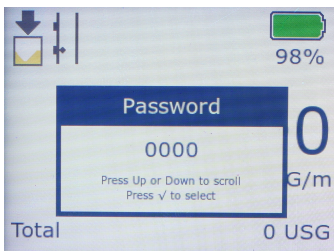

The password (a number from 0000 to 9999) prevents unauthorized access to the Main Menu for programming.

Pressing RIGHT from the Main Display will take you to the Password pop-out screen if the factory default Set Password parameter in the Special Functions menu was changed from 0000. If a password is required, the cursor will automatically be flashing on the leftmost numeral. Press either UP or DOWN to change the selection of that numeral, and RIGHT or LEFT to change the flashing cursor position. Press the CHECK button to accept the password and proceed to the Main Menu, or, press the POWER button to return to the Main Display.

**IMPORTANT:** If you have misplaced your password, contact Pulsar Measurement for assistance recovering it.

**MAIN MENU**

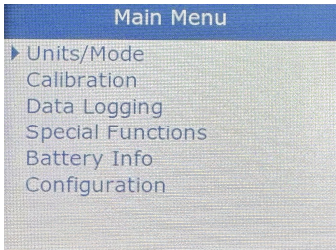

Pressing RIGHT from the Main Display (Set Password in Special Functions = 0000) or CHECK from the Password pop-out (Set Password ≠ 0000) will bring you to the Main Menu screen. The Main Menu functions to provide a simple, easy-to-understand starting point to navigate the programming parameters. The function of each sub-menu is described in subsequent sections. Use UP or DOWN to move the cursor position and RIGHT to navigate into the selected menu.

**UNITS/MODE**

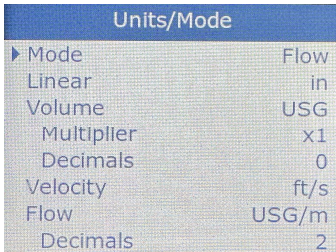

Pressing RIGHT on Units/Mode in the Main Menu will bring you to the Units/Mode programming sub-menu. In this menu you can use UP and DOWN to move the cursor, then RIGHT to access and change any value. When changing a value, a pop-up message will appear. Follow the on-screen prompts to change the value, CHECK to accept the change, or LEFT to cancel.

**Mode** – Select “Flow” (default) or “Velocity” for the mode of operation in the Main Display and Data Log.

**Linear** – Select “in” (inches, default), “ft” (feet), “mm” (millimeters), or “m” (meters) to define distances for pipe diameter.

**Volume** – Select engineering units for the flow volume (totalizer) on the Main Display and Data Log. Options:

Option	Description	Option	Description
<b>USG</b>	US gallons (US default)	<b>m<sup>3</sup></b>	cubic meters
<b>USMG</b>	US million gallons	<b>L</b>	liters (metric default)
<b>IG</b>	imperial gallons	<b>bbl</b>	barrels (1 bbl = 42 USG)
<b>IMG</b>	imperial million gallons	<b>ft<sup>3</sup></b>	cubic feet

**Multiplier** – Select the multiplier for the Volume totalizer. As examples, Multipliers are used when resolution down to the singles place is not required, or when you don’t want to convert from gallons to thousands of gallons. Default = x1.

**Decimals** – Select the number of decimals to show for the Volume totalizer. Default = 0. Options = 0, 1, 2

**Velocity** – Select the units for flow velocity. US Default = “ft/s” (feet per second). Metric Default = “m/s” (meters per second). Options = ft/s or m/s.

**UNITS/MODE (CONT.)**

Units/Mode	
Mode	Flow
Linear	in
Volume	USG
Multiplier	x1
Decimals	0
Velocity	ft/s
Flow	USG/m
Decimals	2

**Flow** – Select engineering units for the flow rate on the Main Display and Data Log. Options:

Option	Description	Option	Description
<b>USG/d</b>	US gallons per day	<b>L/d</b>	liters per day
<b>USG/h</b>	US gallons per hour	<b>L/h</b>	liters per hour
<b>USG/m</b>	US gallons per minute (US default)	<b>L/m</b>	liters per minute
<b>USG/s</b>	US gallons per second	<b>L/s</b>	liters per second (metric default)
<b>ft<sup>3</sup>/d</b>	cubic feet per day	<b>m<sup>3</sup>/d</b>	cubic meters per day
<b>ft<sup>3</sup>/h</b>	cubic feet per hour	<b>m<sup>3</sup>/h</b>	cubic meters per hour
<b>ft<sup>3</sup>/m</b>	cubic feet per minute	<b>m<sup>3</sup>/m</b>	cubic meters per minute
<b>ft<sup>3</sup>/s</b>	cubic feet per second	<b>m<sup>3</sup>/s</b>	cubic meters per second
<b>bbl/d</b>	barrels per day (1 bbl = 42 USG)	<b>IG/d</b>	imperial gallons per day
<b>bbl/h</b>	barrels per hour (1 bbl = 42 USG)	<b>IG/h</b>	imperial gallons per hour
<b>bbl/m</b>	barrels per minute (1 bbl = 42 USG)	<b>IG/m</b>	imperial gallons per minute
<b>bbl/s</b>	barrels per second (1 bbl = 42 USG)	<b>IG/s</b>	imperial gallons per second
<b>USMG/d</b>	US million gallons per day	<b>IMG/d</b>	imperial million gallons per day
<b>USMG/h</b>	US million gallons per hour	<b>IMG/h</b>	imperial million gallons per hour
<b>USMG/m</b>	US million gallons per minute	<b>IMG/m</b>	imperial million gallons per minute
<b>USMG/s</b>	US million gallons per second	<b>IMG/s</b>	imperial million gallons per second

**Decimals** - Select the number of decimals to show for the Flow rate. Default = 0. Options = 0, 1, 2

**CALIBRATION**

Calibration	
Mode	Flow
Min Flow	4.00 USG/m
Signal Cutoff	10%
LOS Time	05 sec
Damping	
Mode	FIR
Percent	10%
Window	1.000 ft/s

**Mode** – Read-only. Shows the selected Mode from the Units/Mode menu.

**Pipe ID** – Enter the Pipe ID for the pipe the sensor is clamped on to. This allows for an accurate conversion from the measured signal (velocity) to flow rate.

**Min Flow** – Enter the Min Flow cutoff, which means any flow rate below Min Flow measured by the PDFM 6.1 will result in 0 flow on the display and data log. Default = 4 GPM (0.25 L/s) for a 4 in (100 mm) nominal pipe, which is the approximately equal to 0.1 ft/s (0.03 m/s) flow velocity. This is the suggested flow velocity to be used for Min Flow values in other nominal pipe sizes. Setting the Min Flow to 0 will result in small measurements to display and accumulate on the totalizer, so this should be avoided.

**LOS Time** – Enter the amount of time the meter will suppress a loss of signal. During the suppression, the meter will HOLD the last measurement until either a good signal is measured in which case normal operation will take place, or if no good signal is measured after the LOS Time is expired, the meter will start reading zero.

**Damping Mode** - Select OFF, FIR (Default), or LOW PASS. When measured flows are outside the Window of the previous measurement, the FIR filter will reduce the damping average so that a fast response can be made to the sudden change in flow rate. The LOW PASS filter will ignore measured flow rates outside the window, while holding the previous measurement, until there are enough measurements made outside the window to cause a step-response to the most current measured value. While measured flows are within the window of the previous measurement, both the FIR and LOW PASS filter behave the same.

**Damping Percent** - Higher percentages increase the number of measurements which are averaged together to produce a stable flow reading. Higher percentages also increase the time it takes for the meter to make a step-response to the measured flow rate outside the window in the LOW PASS Mode. Default = 10%. Options = 0-100%.

**Damping Window** - Defines the window around the running average, in units of Velocity set in the Units/Mode menu. Measurements made inside the window are added to the running average, and measurements outside the window effect the response of the meter as described in the Mode section. Default = 1 ft/s (0.3 m/s). Options = 0-20 ft/s (6.096 m/s).

**Cal Constant** – Calibration constant defined when the PDFM 6.1 was calibrated at the factory. Should this value accidentally be changed, reference the calibration certificate included with the PDFM in order to determine the factory Cal Constant.

## DATA LOGGING

Data Logging	
Log Site ID	00
Logging Mode	Flow
File Format	.LG2
Date	Feb 09/2024
Time	09:38:24
Interval	30 sec
Data Log	Logging
Log in Standby	YES

**Log Site ID** – Enter a number from 00 (Default) to 99. The Site ID will become part of the filename for any file downloaded from the PDFM, to help distinguish from other installation sites. This parameter can be changed at any time.

**Logging Mode** – Select the logging mode. Default = Flow. Options = Flow, Velocity. This setting cannot be changed if Data Log = Logging. Either STOP or DELETE the Data Log to change the Logging Mode.

**File Format** – Choose the file format for downloading the log. Default = .LG2. Options = .LG2, .CSV. LG2 format is used for viewing the logged data with the free Greyline Logger Software. CSV format is used for importing into spreadsheet software like Microsoft Excel. This parameter can be changed at any time.

**Date** – Select the current Date in MMM DD/YYYY format. It is strongly suggested that the Data Log is deleted and restarted after changing the Date, Time, and Interval.

**Time** – Select the current Time in HH:MM:SS format. Options: 00:00:00-23:59:59. It is strongly suggested that the Data Log is deleted and restarted after changing the Date, Time, and Interval.

**Interval** – Select the interval between samples to be stored to the data log. Smaller intervals provide better resolution and understanding of changes in flow rate or velocity over time, at the expense of file size and storage capacity. The PDFM has capacity for approximately 3.8 years of continuous logged data at a 10 second interval. Default = 30 sec. Options = 10 sec, 30 sec, 1 min, 2 min, 5 min, 10 min, 15 min, 30 min, and 60 min.

**Data Log** – Shows the status of the Data Log, and is used to change the status. Logging = Data Log is active. Stopped = Data Log is stopped. Delete = deleted the Data Log and sets the status to Stopped. Start = starts the Data Log and sets the status to Logging. Stop = stops the Data Log and sets the status to Stopped.

**Log In Standby** – Choose YES to enable the option to log in a low-power state. When pressing the POWER button from the Main Screen, a pop-up will prompt you to select either POWER OFF or SLEEP LOGGING. Choose SLEEP LOGGING to log in the low power state. Only valid for Intervals  $\geq$  30s. See specifications section for details on estimated battery life in sleep logging mode.

**IMPORTANT:** It is strongly encouraged to DELETE then START the Data Log after making all your parameter changes in the meter.

## RETRIEVING LOG FILE

Plug a USB-C drive (one is included with the PDFM 6.1) into the USB-C port on the bottom the electronics enclosure. The display will show a downloading icon, then a check mark on the icon when the download is complete. When the check mark appears, the USB-C drive can be removed. The downloaded file name will appear in this format: **PDFM\_0A.LG2**. The "0" will change based on the Log Site ID parameter. The "A" will increment: B, C, etc.; with each subsequent download of the data log.

**SPECIAL FUNCTIONS**

Special Functions	
▶ Language	English
Backlight	High
Mode	Fixed
Reset Totalizer	NO
Neg. Totals	NO
Rev. Flow	Off
Restore Defaults	NO
Capture Parameters	NO
Capture Waveform	NO
Set Password	0000

**Language** – Select the language for the user interface. Options = English (Default), Spanish, or French.

**Backlight** – Select the backlight level, which affects brightness for readability in sunlight, as well as energy usage. Options = Very Low, Low, Medium, High (Default), and Very High. There is approximately 100mA difference in operating current between the Very Low and Very High brightness levels.

**Mode** – Select the mode for the backlight level. Options = Fixed (Default), Dark 10 sec, Dark 30 sec, Dark 60 sec. The “Dark” options will set the backlight to the level selected in the Backlight parameter when any button is pressed, then go to dark (slightly less brightness compared to Backlight = Very Low), until a button is pressed again. When in a “Dark” mode, the first button press after the screen has gone dark will set the brightness to the Backlight level.

**Reset Totalizer** – Selecting Yes will reset the volume totalizer on the Main Display to 0. Choose No or press the LEFT arrow to exit this menu option without making a change.

**Neg. Totals** – This parameter turns the totalizer on the Main Display into a NET totalizer. Positive flow will increment the totalizer, and negative flows will decrement the totalizer. Options = No (Default), Yes.

**Rev. Flow** – This parameter enables the flow direction indication on the PDFM 6.1. When flow velocity moves in the direction opposite of the arrow on the transducer, that is negative when Rev. Flow = ON. Rev. Flow = Invert reverses this orientation. Rev. Flow = Off (Default) ignores transducer orientation, such that all flows are positive (absolute value).

**Restore Defaults** – The parameter restores the configuration settings to the factory default values. Options = US, Metr. The “US” option will set the units in the Units/Mode menu to US/Imperial defaults, while the “Metr” option will set them to the Metric defaults. This parameter does not change any factory calibration settings, like the Cal Constant in the Calibration menu. Nor does it change any settings in the Data Logging menu.

**Capture Parameter** – Choose Yes to download the programming parameters and current measurements to a USB drive. After selecting Yes, the meter will take a couple of seconds to package the parameters, then prompt you to Insert USB (flashing). Insert your USB-C drive when this prompt appears, and the transfer will occur automatically while displaying Saving (flashing). Once the save is complete, the meter will display Done (static). Remove the USB-C drive and the pop-out menu automatically clears.

**SPECIAL FUNCTIONS (Cont.)**

Special Functions	
▶ Language	English
Backlight Mode	High Fixed
Reset Totalizer	NO
Neg. Totals	NO
Rev. Flow	Off
Restore Defaults	NO
Capture Parameters	NO
Capture Waveform	NO
Set Password	0000

**Capture Waveform** – Choose Yes to capture and display the waveform on the display of the PDFM. After selecting Yes, Working (blinking) will appear, and then the waveform will appear on the screen.

If you press the CHECK button while on the Waveform screen, a pop-up message will appear, providing the following options: Exit, Recapture, Save. Choosing Exit will return you to the Special Functions menu. Recapture will take another waveform at that instant and display it on the screen. Save will take the waveform and package it for download to a USB-C drive. When prompted on the screen via Insert USB, insert your USB-C drive into the meter, and the PDFM will save the file.

Pulsar Measurement technical support will occasionally request this waveform file in order to help diagnose and resolve measurement questions.

**Set Password** – The default password of 0000 allows for unrestricted access to the programming Main Menu and its sub-menus. Change the password to restrict access for those who do not know the password.

**BATTERY INFO**

Battery Info	
Battery Voltage	3.736 V
Battery Current	-586.2 mA
Battery Level	53%
USB Voltage	3.200 V
USB Current	0 mA
Charge Current	0 mA
USB Device	None

The Battery Info page is used for diagnostic purposes, and is not used for any configuration of meter behavior.

**Battery Voltage** – Shows the battery voltage in volts (V).

**Battery Current** – Shows the charge (positive) or discharge (negative) current in milliamps (mA).

**Battery Level** – Shows the battery fuel gauge charge percent. Matches the percentage shown on the Main Display and Messages page.

**USB Voltage** – Shows the voltage on the USB connector. Typically 3.2 V when no charger is connected, and 5.0 V when a charger is connected.

**USB Current** – Shows the current from the external USB-C charger.

**Charge Current** – Shows the current into the battery.

**USB Device** – Shows the state of the USB connection: None, Charger, Drive

**CONFIGURATION**

Configuration	
▶ Serial#	000012345
Utility	1.1.11.22
Doppler	1.49.1
Bootloader	1.4

The Configuration page shows the serial number of the PDFM, and the firmware versions of the utility board, transit time board, and bootloader. Pulsar may ask for this information to help diagnose measurement questions.

## SENSOR MOUNTING LOCATION

The position of the sensor is one of the most important considerations for accurate flow measurement. The same location guidelines apply to Doppler as they do for most other flow meter technologies.

**VERTICAL OR HORIZONTAL PIPE** - Vertical pipe runs generally provide evenly distributed flow. On Horizontal pipes and liquids with high concentrations of gas or solids, the sensor should be mounted on the side (3 or 9 o'clock position) to avoid concentrations of gas at the top of the pipe, or solids at the bottom. For liquids with minimal gas bubbles (e.g. potable water) the sensor should be mounted on the top of a horizontal pipe (12 o'clock position) to obtain the best signal strength.

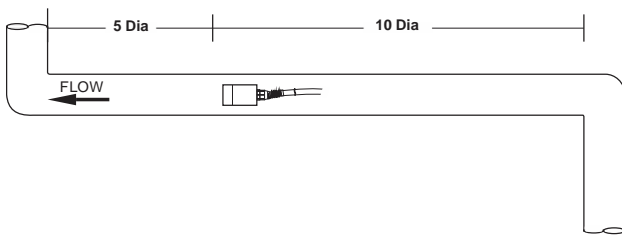
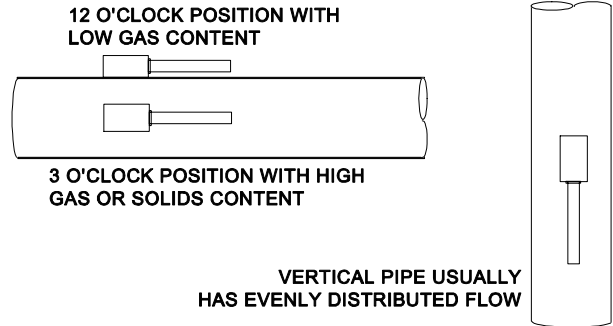

**STRAIGHT RUN REQUIREMENTS** – For best results, the transducers must be installed on a straight run of pipe, free of bends, tees, valves, transitions, insertion probes and obstructions of any kind. **For most installations, ten straight unobstructed pipe diameters upstream and five diameters downstream of the transducers is the minimum recommended distance for proper operation.** Additional considerations are outlined below.

- Do not, if possible, install the transducers downstream from a throttling valve, a mixing tank, the discharge of a positive displacement pump or any other equipment that could possibly aerate the liquid. The best location will be as free as possible from flow disturbances, vibration, sources of heat, noise, or radiated energy.
- Avoid mounting the transducers on a section of pipe with any external scale. Remove all scale, rust, loose paint, etc., from the location prior to mounting the transducers. A sanding block is included with every meter to facilitate proper pipe preparation.
- Do not mount the transducers on a surface aberration (pipe seam, etc.).
- Do not mount transducers from different ultrasonic flow meters on the same pipe.
- Do not run the transducer triaxial cables in common bundles with cables from other instrumentation. You can run these cables through a common conduit **ONLY** if they originate at the same flow meter.
- Never mount transducers under water.

**IMPORTANT NOTE:** In some cases, longer straight runs may be necessary where the transducers are placed downstream from devices which cause unusual flow profile disruptions or swirl. For example: modulating valves, or two elbows in close proximity and out of plane.

## SENSOR MOUNTING

Prepare an area 2" wide by 4" long (50mm x 100mm) for sensor bonding by removing loose paint, scale and rust. The objective of site preparation is to eliminate any discontinuity between the sensor and the pipe wall, which would prevent acoustical coupling.

A PC4 Sensor Mounting Kit is supplied with each flow meter. It includes recommended coupling compound and a stainless steel mounting bracket with adjustable pipe straps.

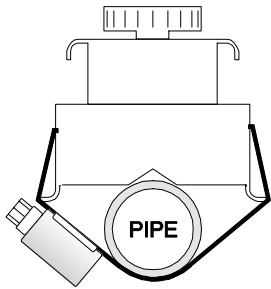

END VIEW

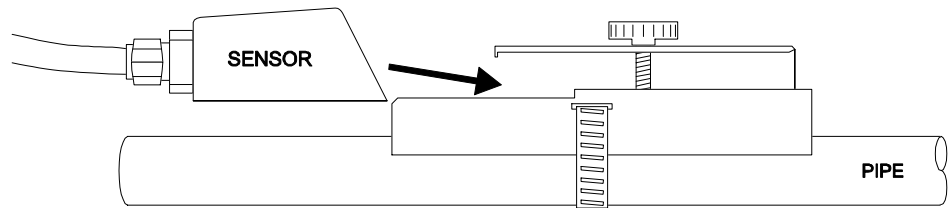

Mount the PC4 pipe clamp as illustrated on pipes 0.6" / 15 mm OD or larger. Stainless steel bands are included for mounting on pipes up to 32" / 81 cm OD.

Additional stainless steel bands (by customer) may be combined to mount on pipes up to 180" / 4.5 m OD.

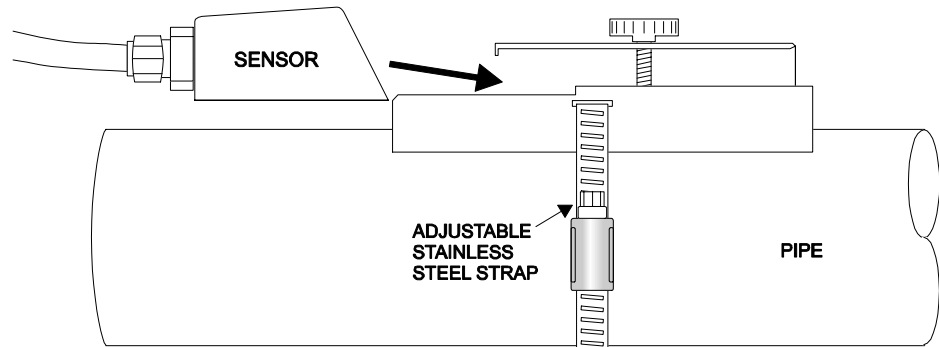
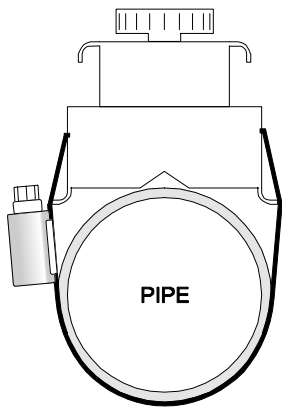

### SENSOR COUPLING

For permanent or temporary bonding, the following are recommended:

- a) Super Lube ® (supplied)  
Additional supply: order Option CC-SL30 or your local home improvement store.
- b) Electrocardiograph gel
- c) Petroleum gel (Vaseline)

The above are arranged in their order of preferred application.  
b & c are only good for temporary bonding at room temperature.  
DO NOT USE: Silicon RTV caulking compound (silicon rubber).

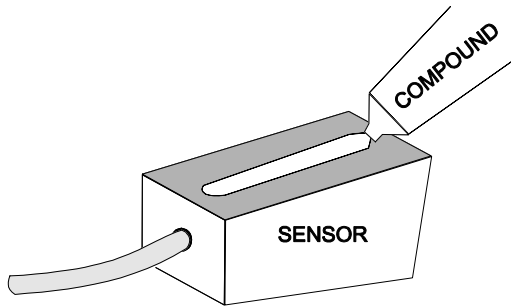

Use the PC4 pipe clamp (supplied) as illustrated on the previous page. Apply Super Lube ® to the colored face of the sensor. A bead, similar to toothpaste on a toothbrush, is ideal. Do not overtighten (crush the sensor).

The sensor must be fixed securely to the pipe with coupling material between the sensor face and the pipe. Sensor installation with excessive coupling compound can result in gaps or voids in the coupling and cause errors or loss of signal. Insufficient coupling compound will create similar conditions.

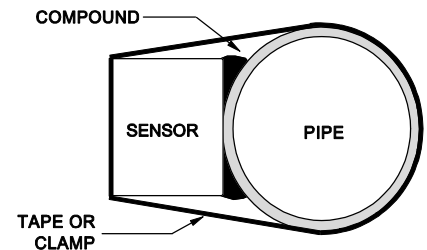

Over time temporary coupling compounds (e.g. Petroleum Gel) may gradually sag away from the sensor resulting in reduced signal strength and finally complete loss of signal. Warm temperatures, moisture and vibration will accelerate this process. Super Lube ® as supplied with the DFM 6.1 (and available from Pulsar Measurement or home improvement stores) is recommended for semi-permanent installations.

**SENSOR MOUNTING/COUPLING RECOMMENDATIONS**

**BAD**

Avoid air traveling at the top of a horizontal pipe.

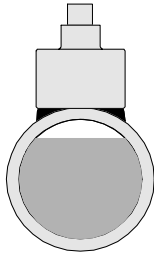

Avoid debris traveling at the bottom of a horizontal pipe.

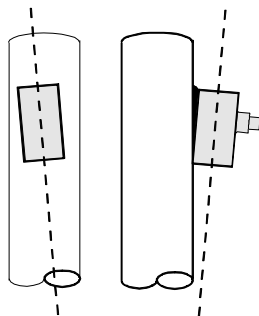
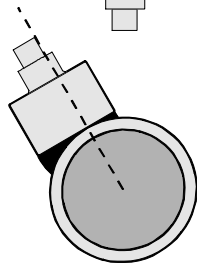
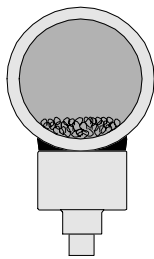

**GOOD**

Installing between 1 and 5 o'clock, and 7 and 11 o'clock on horizontal pipes is acceptable.

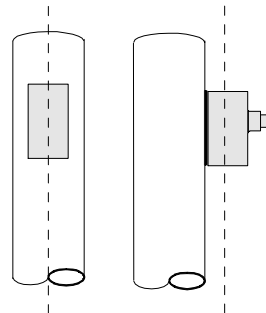
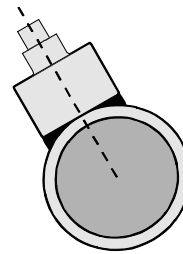
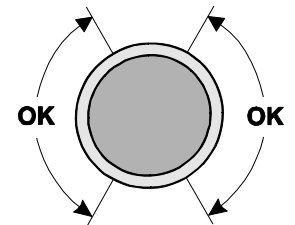
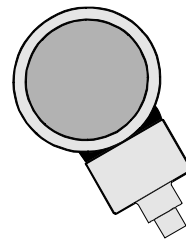
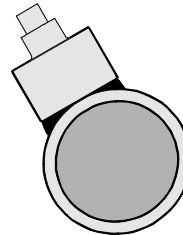

## COMMON QUESTIONS AND ANSWERS

*The pipe vibrates. Will it affect the flow meter?*

Common vibration frequencies are far lower than the sonic frequencies used by the flow meter and will not normally affect accuracy or performance. However, applications where very weak Doppler signal is present (when sensitivity is adjusted to maximum and signal strength is low), accuracy may be affected by pipe vibration, or the flow meter may show readings under no-flow conditions. Attempt to relocate the sensor on a pipe section where vibration is reduced, or arrange pipe mounting brackets to reduce vibration at the sensor mounting location.

*The flow meter must be installed in a high noise environment. Will this affect operation?*

Our flow meters are designed to discriminate between environmental noise and the Doppler signal. High noise environments may affect the flow meter's performance where low signal strength and/or low flow velocities are being measured.

*Will pipe corrosion affect accuracy of the flow meter?*

Yes. Rust, loose paint etc. must be removed from the outside of the pipe to provide a clean mounting position when installing a Doppler sensor. Severe corrosion/oxidation on the inside of the pipe may prevent the Doppler signal from penetrating into the flow. If the pipe cannot be cleaned, a spool piece (PVC recommended) should be installed for sensor mounting.

*What effect do pipe liners have on the flow meter?*

The air gap between loose insertion liners and the pipe wall prevent the Doppler signal from entering the flow. Better results can be expected with bonded liners such as cement, epoxy or tar, however an on site test is recommended to determine if the application is suitable for a Doppler flow meter.

*Why is Doppler only recommended for liquids containing suspended solids or gases?*

The Doppler sensor transmits sound into the flow stream which must be reflected back to the sensor to indicate flow velocity. Gas bubbles or suspended solids act as reflectors for the Doppler signal. As a guideline, our Doppler flow meters are recommended for liquids containing solids or bubbles with a minimum size of 100 microns and a minimum concentration of 75 ppm. Most applications (except potable, distilled or deionized water) will meet this minimum requirement.

*Can the sensor be submerged in water?*

Yes, for short periods of time or by accident, but it is not recommended for continuous operation. The sensor is constructed to withstand submersion to 10 psi without damage, but external liquid moving in contact with the sensor can be interpreted as flow and cause false readings.

*What is the purpose of the Signal Strength Display?*

Doppler signals of very low strength are not accepted or processed by the instrument. This feature assists in rejection of environmental noise and vibration. Use the display to evaluate signal strength in your application. Strong signals will increase in percentage to a maximum of 100% or greater.

**COMMON QUESTIONS AND ANSWERS (Cont.)**

*Can I change the length of the sensor cable?*

Yes. The optional PXC4 sensor cable extension kit is available, which will extend the cable an additional 50 feet (15 meters) for a total length of 62 feet (18.5 meters).

*Does the PDFM 6.1 require periodic recalibration?*

PDFM 6.1 calibration does not drift over time. The solid-state sensor has no moving parts to wear and affect calibration. The Doppler flow technique generates an ultrasonic signal proportional to the velocity of flow. All timing/counting circuits use crystal-controlled frequency references to eliminate any drift in the processing circuitry.

ISO 9000 or similar quality management systems may require periodic and verifiable recalibration of flow meters. PDFM 6.1 Doppler Flow Meters may be returned to Pulsar Measurement for factory calibration and issue of a new NIST traceable certificate. Refer to the 'Product Return Procedure' section of this manual for return instructions.

**APPLICATIONS HOTLINE**

For applications assistance, advice or information on any Pulsar Measurement instrument contact your Sales Representative, write to Pulsar Measurement or phone the Applications Hotline below:

COUNTRY	TEL	FAX	E-MAIL	ADDRESS
<b>United States</b>	888-473-9546	613-938-4857	<a href="mailto:northamerica@pulsarmeasurement.com">northamerica@pulsarmeasurement.com</a>	11451 Belcher Road South Largo, FL 33773
<b>Canada</b>	855-300-9151	613-938-4857	<a href="mailto:northamerica@pulsarmeasurement.com">northamerica@pulsarmeasurement.com</a>	16456 Sixsmith Drive Long Sault, Ont. K0C 1P0
<b>UK</b>	+44 (0) 1684 891371	+44 (0) 1684 575985	<a href="mailto:europa@pulsarmeasurement.com">europa@pulsarmeasurement.com</a>	Cardinal Building Enigma Commercial Centre Sandy's Road, Malvern WR14 1JJ
<b>Asia</b>	N/A	N/A	<a href="mailto:asiapacific@pulsarmeasurement.com">asiapacific@pulsarmeasurement.com</a>	34-1A, Jalan 10A/KU5 Taman Aman Perdana 41050 Klang, Selangor, Malaysia
<b>Oceania</b>	+61 428 692 274	N/A	<a href="mailto:oceania@pulsarmeasurement.com">oceania@pulsarmeasurement.com</a>	N/A

**PRODUCT RETURN PROCEDURE**

Instruments may be returned to Pulsar Measurement for service or warranty repair.

**1 Obtain an RMA Number from Pulsar Measurement -**

Before shipping a product to the factory please contact Pulsar Measurement by telephone, fax or email to obtain an RMA number (Returned Merchandise Authorization). This ensures fast service and correct billing or credit.

When you contact Pulsar Measurement please have the following information available:

1. Model number / Software Version
2. Serial number
3. Date of Purchase
4. Reason for return (description of fault or modification required)
5. Your name, company name, address and phone number

**2 Clean the Sensor/Product -**

***Important: unclean products will not be serviced and will be returned to the sender at their expense.***

1. Rinse sensor and cable to remove debris.
2. If sensor has been exposed to sewage, immerse both sensor and cable in a solution of 1 part household bleach (Javex, Clorox etc.) to 20 parts water for 5 minutes. Important: do not immerse open end of sensor cable.
3. Dry with paper towels and pack sensor and cable in a sealed plastic bag.
4. Wipe the outside of the enclosure to remove dirt or deposits.
5. Return to Pulsar Measurement for service.

## LIMITED WARRANTY

---

Pulsar Measurement warrants, to the original purchaser, its products to be free from defects in material and workmanship for a period of two years from date of invoice. Pulsar Measurement will replace or repair, free of charge, any Pulsar product if it has been proven to be defective within the warranty period. This warranty does not cover any expenses incurred in the removal and re-installation of the product.

If a product manufactured by Pulsar should prove defective within the first year, return it freight prepaid to Pulsar Measurement along with a copy of your invoice.

This warranty does not cover damages due to improper installation or handling, acts of nature, or unauthorized service. Modifications to or tampering with any part shall void this warranty. This warranty does not cover any equipment used in connection with the product or consequential damages due to a defect in the product.

All implied warranties are limited to the duration of this warranty. This is the complete warranty by Pulsar Measurement and no other warranty is valid against Pulsar Measurement. Some states do not allow limitations on how long an implied warranty lasts or limitation of incidental or consequential damages, so the above limitations or exclusions may not apply to you.

This warranty gives you specific legal rights, and you may also have other rights which vary from state to state.

Pulsar Measurement

## SPECIFICATIONS

### General Specifications

<b>Operating Parameters:</b>	Liquids containing suspended solids or bubbles minimum size of 100 microns, minimum concentration 75 ppm.														
<b>Flow Rate Range:</b>	±0.03 m/s to 12.2 m/s (±0.1 ft/s to 40 ft/s) in most applications														
<b>Pipe Size:</b>	Ultrasonic sensor mounts on any pipe from 12.7 mm to 4.6 m ID (0.5 in to 15 ft)														
<b>Display:</b>	Color TFT LCD display, IPS type, 2.8" screen size, 320 x 240 resolution, 500 NITS brightness, super wide view														
<b>Power Input:</b>	<ul style="list-style-type: none"> <li>Built-in rechargeable lithium polymer battery for up to 15 hours continuous operation</li> <li>External mains to USB-C charger with 100-240V AC, 50-60Hz, 0.6A input; and 5.0V DC, 3A, 15W output</li> </ul>														
<b>Outputs:</b>	Log files, daily log files, parameter settings files, and waveform capture files via USB-C flash drive (included)														
<b>Data Logger:</b>	12 million point capacity, configurable for velocity or flow rate, date and time stamped, configurable format for Greyline Logger Software (LG2) or CSV, available intervals of 10 s, 30 s, 1 min, 2 min, 5 min, 10 min, 15 min, 30 min, and 1 hr														
<b>Extended Logging:</b>	<p>Can be deployed in sleep-logging mode for extended battery duration.</p> <table border="1"> <thead> <tr> <th>Log Interval</th> <th>30 s</th> <th>1 min</th> <th>2 min</th> <th>5 min</th> <th>10 min</th> <th>15 min</th> </tr> </thead> <tbody> <tr> <th>Est. Batt. Duration</th> <td>5 days</td> <td>8 days</td> <td>15 days</td> <td>30 days</td> <td>45 days</td> <td>60 days</td> </tr> </tbody> </table>	Log Interval	30 s	1 min	2 min	5 min	10 min	15 min	Est. Batt. Duration	5 days	8 days	15 days	30 days	45 days	60 days
Log Interval	30 s	1 min	2 min	5 min	10 min	15 min									
Est. Batt. Duration	5 days	8 days	15 days	30 days	45 days	60 days									
<b>PC Software:</b>	Free Greyline Logger Software for Windows. For display, manipulation, analysis, and exporting of data.														
<b>Operating Temp. (Electronics):</b>	-20 °C to +60 °C (-5 °F to +140 °F)														
<b>Electronics Enclosure:</b>	IP67 when transducer cables connected. IP65 when transducers cables not connected. Aluminum enclosure with silicone protective end covers.														
<b>Carry Case:</b>	IP67, with protective molded foam with room for transducer and installation hardware														
<b>Accuracy:</b>	±2% of reading or 0.03 m/s (0.1 ft/s), whichever is greater. Requires solids or bubbles minimum size of 100 microns, minimum concentration 75 ppm. Repeatability: ±0.1%, Linearity ±0.5%														
<b>Configuration:</b>	Built-in 5-button keypad interface with English, French, and Spanish menu language selection. Optional user-configured password protection.														
<b>Approvals:</b>	CE														
<b>Approximate Shipping Weight:</b>	4.5 kg (14 lbs)														

**SPECIFICATIONS (Cont.)**

**Transducer Specifications**

<b>Standard Model PSE4-A2:</b>	Clamp-on, single-head ultrasonic for pipes from 12.7 mm to 4.6 m ID (0.5 in to 15 ft) with 3.4 m (12 ft) shielded dual-coaxial cable and latching connector
<b>Sensor Mounting Kit:</b>	Stainless steel pipe clamp and 3.0 fl oz coupling compound
<b>Pipe Materials:</b>	Steel, stainless steel, cast iron, ductile iron, concrete-lined ductile iron, PVC, HDPE, or any contiguous pipe material that conducts sound, including lined pipes with a liner bonded to the pipe wall. Avoid pipes with loose insertion liners and pipe walls that contain air.
<b>Operating Temperature:</b>	-40 °C to +150 °C (-40 °F to +300 °F)
<b>Ingress Protection:</b>	IP68, can withstand 10psi (approx. 23 ft or 7 m of H2O) for 24 hours

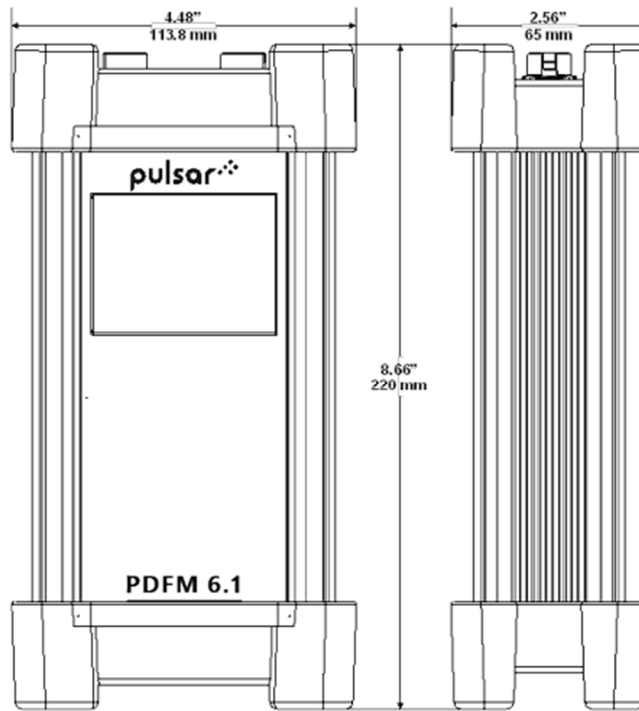

Enclosure

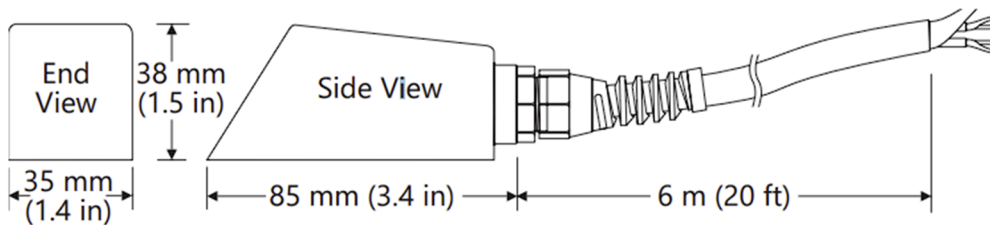

SE4 Ultrasonic Doppler Sensor

**APPENDIX A - CONVERSION TABLE**

CONVERSION GUIDE		
FROM	TO	MULTIPLY BY
US GALLONS	CUBIC FEET	0.1337
US GALLONS	IMPERIAL GALS	0.8327
US GALLONS	LITRES	3.785
US GALLONS	CUBIC METERS	0.003785
LITRES/SEC	GPM	15.85
LITRES	CUBIC METERS	0.001
BARRELS	US GALLONS	42
BARRELS	IMPERIAL GALS	34.9726
BARRELS	LITRES	158.9886
INCHES	MM	25.4
DEGREES F	DEGREES C	$(^{\circ}\text{F}-32) \times 0.556$
POUNDS	KILOGRAMS	0.453
PSI	BAR	0.0676
FOOT <sup>2</sup>	METER <sup>2</sup>	0.0929

Note: BARRELS are U.S. oil barrels.

**APPENDIX B - PIPE CHARTS**

**Carbon Steel & PVC Pipe**

Pipe Size	Pipe O.D.	Standard Schedule 40		Extra Heavy Schedule 80		Dbl. Extra Heavy		Schedule 10		Schedule 20		Schedule 30		Schedule 40	
		I.D.	WALL	I.D.	WALL	I.D.	WALL	I.D.	WALL	I.D.	WALL	I.D.	WALL	I.D.	WALL
½	.840	.622	.109	.546	.147	.252	.294							.622	.109
¾	1.050	.824	.113	.742	.154	.434	.308							.824	.113
1	1.315	1.049	.133	.957	.179	.599	.358							1.049	.133
1¼	1.660	1.380	.140	1.278	.191	.896	.382							1.380	.140
1½	1.900	1.610	.145	1.500	.200	1.100	.400							1.610	.145
2	2.375	2.067	.154	1.939	.218	1.503	.436							2.067	.154
2½	2.875	2.469	.203	2.323	.276	1.771	.552							2.469	.203
3	3.500	3.068	.216	2.900	.300	2.300	.600							3.068	.216
3½	4.000	3.548	.226	3.364	.318	2.728	.636							3.548	.226
4	4.500	4.026	.237	3.826	.337	3.152	.674							4.026	.237
5	5.563	5.047	.258	4.813	.375	4.063	.750							5.047	.258
6	6.625	6.065	.280	5.761	.432	4.897	.864							6.065	.280
8	8.625	7.981	.322	7.625	.500	6.875	.875			8.125	.250	8.071	.277	7.981	.322
10	10.750	10.020	.365	9.750	.500	8.750	1.000			10.250	.250	10.136	.307	10.020	.365
12	12.750	12.000	.375	11.750	.500	10.750	1.000			12.250	.250	12.090	.330	11.938	.406
14	14.000	13.250	.375	13.000	.500			13.500	.250	13.376	.312	13.250	.375	13.124	.438
16	16.000	15.250	.375	15.000	.500			15.500	.250	15.376	.312	15.250	.375	15.000	.500
18	18.000	17.250	.375	17.000	.500			17.500	.250	17.376	.312	17.124	.438	16.876	.562
20	20.000	19.250	.375	19.000	.500			19.500	.250	19.250	.375	19.000	.500	18.814	.593
22	22.000	21.250	.375	21.000	.500			21.500	.250	21.250	.375	21.000	.500		
24	24.000	23.250	.375	23.000	.500			23.500	.250	23.250	.375	22.876	.562	22.626	.687
26	26.000	25.250	.375	25.000	.500			25.376	.312	25.000	.500				
28	28.000	27.250	.375	27.000	.500			27.376	.312	27.000	.500	26.750	.625		
30	30.000	29.250	.375	29.000	.500			29.376	.312	29.000	.500	28.750	.625		
32	32.000	31.250	.375	31.000	.500			31.376	.312	31.000	.500	30.750	.625		
34	34.000	33.250	.375	33.000	.500			33.376	.312	33.000	.500	32.750	.625		
36	36.000	35.250	.375	35.000	.500			35.376	.312	35.000	.500	34.750	.625		
42	42.000	41.250	.375	41.000	.500					41.000	.500	40.750	.625		

**Ductile Iron Pipe - Standard Classes**

Size INCH	OUTSIDE DIA. INCH	Class 50		Class 51		Class 52		Class 53		Class 54		Class 55		Class 56		CEMENT LINING	
		WALL	I.D.	WALL	I.D.	WALL	I.D.	WALL	I.D.	WALL	I.D.	WALL	I.D.	WALL	I.D.	**STD	**DOUBLE
																THICKNESS	THICKNESS
3	3.96			0.25	3.46	0.28	3.40	0.31	3.34	0.34	3.28	0.37	3.22	0.41	3.14		
4	4.80			0.26	4.28	0.29	4.22	0.32	4.16	0.35	4.10	0.38	4.04	0.44	3.93		
6	6.90	0.25	6.40	0.28	6.34	0.31	6.28	0.34	6.22	0.37	6.16	0.40	6.10	0.43	6.04	.125	.250
8	9.05	0.27	8.51	0.30	8.45	0.33	8.39	0.36	8.33	0.39	8.27	0.42	8.21	0.45	8.15		
10	11.10	0.39	10.32	0.32	10.46	0.35	10.40	0.38	10.34	0.41	10.28	0.44	10.22	0.47	10.16		
12	13.20	0.31	12.58	0.34	12.52	0.37	12.46	0.40	12.40	0.43	12.34	0.46	12.28	0.49	12.22		
14	15.30	0.33	14.64	0.36	14.58	0.39	14.52	0.42	14.46	0.45	14.40	0.48	14.34	0.51	14.28		
16	17.40	0.34	16.72	0.37	16.66	0.40	16.60	0.43	16.54	0.46	16.48	0.49	16.42	0.52	16.36		
18	19.50	0.35	18.80	0.38	18.74	0.41	18.68	0.44	18.62	0.47	18.56	0.50	18.50	0.53	18.44	.1875	.375
20	21.60	0.36	20.88	0.39	20.82	0.42	20.76	0.45	20.70	0.48	20.64	0.51	20.58	0.54	20.52		
24	25.80	0.38	25.04	0.41	24.98	0.44	24.92	0.47	24.86	0.50	24.80	0.53	24.74	0.56	24.68		
30	32.00	0.39	31.22	0.43	31.14	0.47	31.06	0.51	30.98	0.55	30.90	0.59	30.82	0.63	30.74		
36	38.30	0.43	37.44	0.48	37.34	0.62	37.06	0.58	37.14	0.63	37.04	0.68	36.94	0.73	36.84		
42	44.50	0.47	43.56	0.53	43.44	0.59	43.32	0.65	43.20	0.71	43.08	0.77	42.96	0.83	42.84	.250	.500
48	50.80	0.51	49.78	0.58	49.64	0.65	49.50	0.72	49.36	0.79	49.22	0.86	49.08	0.93	48.94		
54	57.10	0.57	55.96	0.65	55.80	0.73	55.64	0.81	55.48	0.89	55.32	0.97	55.16	1.05	55.00		

\*\*REDUCE I.D. BY DIMENSION SHOWN

**Stainless Steel, Hastelloy "C" & Titanium Pipe**

Pipe Size	Pipe O.D.	Schedule 5 S (a)		Schedule 10 S (a)		Schedule 40 S		Schedule 80 S	
		I.D.	WALL	I.D.	WALL	I.D.	WALL	I.D.	WALL
½	.840	.710	.065	.674	.083	.622	.109	.546	.147
¾	1.050	.920	.065	.884	.083	.824	.113	.742	.154
1	1.315	1.185	.065	1.097	.109	1.049	.133	.957	.179
1¼	1.660	1.530	.065	1.442	.109	1.380	.140	1.278	.191
1½	1.900	1.770	.065	1.682	.109	1.610	.145	1.500	.200
2	2.375	2.245	.065	2.157	.109	2.067	.154	1.939	.218
2½	2.875	2.709	.083	2.635	.120	2.469	.203	2.323	.276
3	3.500	3.334	.083	3.260	.120	3.068	.216	2.900	.300
3½	4.000	3.834	.083	3.760	.120	3.548	.226	3.364	.318
4	4.500	4.334	.083	4.260	.120	4.026	.237	3.826	.337
5	5.563	5.345	.109	5.295	.134	5.047	.258	4.813	.375
6	6.625	6.407	.109	6.357	.134	6.065	.280	5.761	.432
8	8.625	8.407	.109	8.329	.148	7.981	.322	7.625	.500
10	10.750	10.482	.134	10.420	.165	10.020	.365	9.750	.500
12	12.750	12.438	.156	12.390	.180	12.000	.375	11.750	.500
14	14.000	13.688	.156	13.624	.188				
16	16.000	15.670	.165	15.624	.188				
18	18.000	17.670	.165	17.624	.188				
20	20.000	19.634	.188	19.564	.218				
22	22.000	21.624	.188	21.564	.218				
24	24.000	23.563	.218	23.500	.250				

Pipe Size	Pipe O.D.	Schedule 60		Schedule 80		Schedule 100		Schedule 120		Schedule 140		Schedule 160	
		I.D.	WALL	I.D.	WALL	I.D.	WALL	I.D.	WALL	I.D.	WALL	I.D.	WALL
½	.840			.546	.147							.466	.187
¾	1.050			.742	.154							.614	.218
1	1.315			.957	.179							.815	.250
1¼	1.660			1.278	.191							1.160	.250
1½	1.900			1.500	.200							1.338	.281
2	2.375			1.939	.218							1.689	.343
2½	2.875			2.323	.276							2.125	.375
3	3.500			2.900	.300							2.624	.438
3½	4.000			3.364	.318								
4	4.500			3.826	.337			3.624	.438			3.438	.531
5	5.563			4.813	.375			4.563	.500			4.313	.625
6	6.625			5.761	.432			5.501	.562			5.189	.718
8	8.625	7.813	.406	7.625	.500	7.439	.593	7.189	.718	7.001	.812	6.813	.906
10	10.750	9.750	.500	9.564	.593	9.314	.718	9.064	.843	8.750	1.000	8.500	1.125
12	12.750	11.626	.562	11.376	.687	11.064	.843	10.750	1.000	10.500	1.125	10.126	1.312
14	14.000	12.814	.593	12.500	.750	12.126	.937	11.814	1.093	11.500	1.250	11.188	1.406
16	16.000	14.688	.656	14.314	.843	13.938	1.031	13.564	1.218	13.124	1.438	12.814	1.593
18	18.000	16.500	.750	16.126	.937	15.688	1.156	15.250	1.375	14.876	1.562	14.438	1.781
20	20.000	18.376	.812	17.938	1.031	17.438	1.281	17.000	1.500	16.500	1.750	16.064	1.968
22	22.000	20.250	.875	19.750	1.125	19.250	1.375	18.750	1.625	18.250	1.875	17.750	2.125
24	24.000	22.064	.968	21.564	1.218	20.938	1.531	20.376	1.812	19.876	2.062	19.314	2.343

**Cast Iron Pipe - ASA Standard**

Pipe Size	Pipe O.D.	Class 50		Class 100		Class 150		Class 200		Class 250		Class 300		Class 350	
		WALL	I.D.	WALL	I.D.	WALL	I.D.	WALL	I.D.	WALL	I.D.	WALL	I.D.	WALL	I.D.
3	3.96	0.32	3.32	0.32	3.32	0.32	3.32	0.32	3.32	0.32	3.32	0.32	3.32	0.32	3.32
4	4.80	0.35	4.10	0.35	4.10	0.35	4.10	0.35	4.10	0.35	4.10	0.35	4.10	0.35	4.10
6	6.90	0.38	6.14	0.38	6.14	0.38	6.14	0.38	6.14	0.38	6.14	0.38	6.14	0.38	6.14
8	9.05	0.41	8.23	0.41	8.23	0.41	8.23	0.41	8.23	0.41	8.23	0.41	8.23	0.41	8.23
10	11.10	0.44	10.22	0.44	10.22	0.44	10.22	0.44	10.22	0.44	10.22	0.48	10.14	0.52	10.06
12	13.20	0.48	12.24	0.48	12.24	0.48	12.24	0.48	12.24	0.52	12.16	0.52	12.16	0.56	12.08
14	15.30	0.48	14.34	0.51	14.28	0.51	14.28	0.55	14.20	0.59	14.12	0.59	14.12	0.64	14.02
16	17.40	0.54	16.32	0.54	16.32	0.54	16.32	0.58	16.24	0.63	16.14	0.68	16.04	0.68	16.04
18	19.50	0.54	18.42	0.58	18.34	0.58	18.34	0.63	18.24	0.68	18.14	0.73	18.04	0.79	17.92
20	21.60	0.57	20.46	0.62	20.36	0.62	20.36	0.67	20.26	0.72	20.16	0.78	20.04	0.84	19.92
24	25.80	0.63	24.54	0.68	24.44	0.73	24.34	0.79	24.22	0.79	24.22	0.85	24.10	0.92	23.96

**Cast Iron Pipe - AWWA Standard**

Pipe Size	Class A 100 Ft. 43 PSIG			Class B 200 Ft. 86 PSIG			Class C 300 Ft. 130 PSIG			Class D 400 Ft. 173 PSIG		
	O.D.	WALL	I.D.	O.D.	WALL	I.D.	O.D.	WALL	I.D.	O.D.	WALL	I.D.
3	3.80	0.39	3.02	3.96	0.42	3.12	3.96	0.45	3.06	3.96	0.48	3.00
4	4.80	0.42	3.96	5.00	0.45	4.10	5.00	0.48	4.04	5.00	0.52	3.96
6	6.90	0.44	6.02	7.10	0.48	6.14	7.10	0.51	6.08	7.10	0.55	6.00
8	9.05	0.46	8.13	9.05	0.51	8.03	9.30	0.56	8.18	9.30	0.60	8.10
10	11.10	0.50	10.10	11.10	0.57	9.96	11.40	0.62	10.16	11.40	0.68	10.04
12	13.20	0.54	12.12	13.20	0.62	11.96	13.50	0.68	12.14	13.50	0.75	12.00
14	15.30	0.57	14.16	15.30	0.66	13.98	15.65	0.74	14.17	15.65	0.82	14.01
16	17.40	0.60	16.20	17.40	0.70	16.00	17.80	0.80	16.20	17.80	0.89	16.02
18	19.50	0.64	18.22	19.50	0.75	18.00	19.92	0.87	18.18	19.92	0.96	18.00
20	21.60	0.67	20.26	21.60	0.80	20.00	22.06	0.92	20.22	22.06	1.03	20.00
24	25.80	0.76	24.28	25.80	0.89	24.02	26.32	1.04	24.22	26.32	1.16	24.00
30	31.74	0.88	29.98	32.00	1.03	29.94	32.40	1.20	30.00	32.74	1.37	30.00
36	37.96	0.99	35.98	38.30	1.15	36.00	38.70	1.36	39.98	39.16	1.58	36.00
42	44.20	1.10	42.00	44.50	1.28	41.94	45.10	1.54	42.02	45.58	1.78	42.02
48	50.50	1.26	47.98	50.80	1.42	47.96	51.40	1.71	47.98	51.98	1.96	48.06
54	56.66	1.35	53.96	57.10	1.55	54.00	57.80	1.90	54.00	58.40	2.23	53.94
60	62.80	1.39	60.02	63.40	1.67	60.06	64.20	2.00	60.20	64.82	2.38	60.06
72	75.34	1.62	72.10	76.00	1.95	72.10	76.88	2.39	72.10			
84	87.54	1.72	84.10	88.54	2.22	84.10						

Pipe Size	Class E 500 Ft. 217 PSIG			Class F 600 Ft. 260 PSIG			Class G 700 Ft. 304 PSIG			Class H 800 Ft. 347 PSIG		
	O.D.	WALL	I.D.	O.D.	WALL	I.D.	O.D.	WALL	I.D.	O.D.	WALL	I.D.
6	7.22	0.58	6.06	7.22	0.61	6.00	7.38	0.65	6.08	7.38	0.69	6.00
8	9.42	0.66	8.10	9.42	0.71	8.00	9.60	0.75	8.10	9.60	0.80	8.00
10	11.60	0.74	10.12	11.60	0.80	10.00	11.84	0.86	10.12	11.84	0.92	10.00
12	13.78	0.82	12.14	13.78	0.89	12.00	14.08	0.97	12.14	14.08	1.04	12.00
14	15.98	0.90	14.18	15.98	0.99	14.00	16.32	1.07	14.18	16.32	1.16	14.00
16	18.16	0.98	16.20	18.16	1.08	16.00	18.54	1.18	16.18	18.54	1.27	16.00
18	20.34	1.07	18.20	20.34	1.17	18.00	20.78	1.28	18.22	20.78	1.39	18.00
20	22.54	1.15	20.24	22.54	1.27	20.00	23.02	1.39	20.24	23.02	1.51	20.00
24	26.90	1.31	24.28	26.90	1.45	24.00	27.76	1.75	24.26	27.76	1.88	24.00
30	33.10	1.55	30.00	33.46	1.73	30.00						
36	39.60	1.80	36.00	40.04	2.02	36.00						

**Copper Tubing**

Pipe Size	K			L			M			Copper & Brass Pipe			Aluminum		
	O.D.	I.D.	WALL	O.D.	I.D.	WALL	O.D.	I.D.	WALL	O.D.	I.D.	WALL	O.D.	I.D.	WALL
½"	0.625	0.527	0.049	0.625	0.545	0.040	0.625	0.569	0.028	0.840	0.625	0.108			
⅝"	0.750	0.652	0.049	0.750	0.666	0.042	0.750	0.690	0.030						
¾"	0.875	0.745	0.065	0.875	0.785	0.045	0.875	0.811	0.032	1.050	0.822	0.114			
1"	1.125	0.995	0.065	1.125	1.025	0.050	1.125	1.055	0.035	1.315	1.062	0.127			
1 ¼"	1.375	1.245	0.065	1.375	1.265	0.055	1.375	1.291	0.042	1.660	1.368	0.146			
1 ½"	1.625	1.481	0.072	1.625	1.505	0.060	1.625	1.527	0.049	1.900	1.600	0.150			
2"	2.125	1.959	0.083	2.125	1.985	0.070	2.125	2.009	0.058	2.375	2.062	0.157			
2 ½"	2.625	2.435	0.095	2.625	2.465	0.080	2.625	2.495	0.065	2.875	2.500	0.188	2.500	2.400	0.050
3"	3.125	2.907	0.109	3.125	2.945	0.090	3.125	2.981	0.072	3.500	3.062	0.219	3.000	2.900	0.050
3 ½"	3.625	3.385	0.120	3.625	3.425	0.100	3.625	3.459	0.083	4.000	3.500	0.250			
4"	4.125	3.857	0.134	4.125	3.905	0.110	4.125	3.935	0.095	4.500	3.935	0.095	4.000	4.000	0.250
4 ½"													5.000	4.500	0.250
5"	5.125	4.805	0.160	5.125	4.875	0.125	5.125	4.907	0.109	5.563	5.063	0.250	5.000	4.874	0.063
6"	6.125	5.741	0.192	6.125	5.845	0.140	6.125	5.881	0.122	6.625	6.125	0.250	6.000	5.874	0.063
7"										7.625	7.062	0.282	7.000	6.844	0.078
8"	8.125	7.583	0.271	8.125	7.725	0.200	8.125	7.785	0.170	8.625	8.000	0.313	8.000	7.812	0.094
10"	10.125	9.449	0.338	10.125	9.625	0.250	10.125	9.701	0.212	10.000	9.812	0.094			
12"	12.125	11.315	0.405	12.125	11.565	0.280	12.125	11.617	0.254						



[www.pulsarmeasurement.com](http://www.pulsarmeasurement.com)

Copyright © 2024 Pulsar Measurement Ltd.  
 Registered Address: 1 Chamberlain Square CS, Birmingham B3 3AX  
 Registered No.: 3345604 England & Wales  
 Rev 1.0