

# Technical Information

## Cerabar PMC21

### IO-Link

Process pressure measurement



Pressure transducer with ceramic sensors

#### Application

The Cerabar is a pressure transducer for the measurement of absolute and gauge pressure in gases, vapors, liquids and dust. The Cerabar can be used internationally thanks to a wide range of approvals and process connections.















#### Your benefits

- High reproducibility and long-term stability
- Reference accuracy: up to 0.3%
- Customized measuring ranges
  - Turn down up to 5:1
  - Sensor for measuring ranges up to 40 bar (600 psi)
- Housing made of 316L
- Ceramic process membrane

## Table of contents

<b>About this document</b> . . . . .	<b>3</b>	<b>Environment</b> . . . . .	<b>14</b>
Document function . . . . .	3	Ambient temperature range . . . . .	14
Symbols . . . . .	3	Storage temperature range . . . . .	14
Documentation . . . . .	3	Climate class . . . . .	15
Terms and abbreviations . . . . .	4	Degree of protection . . . . .	15
Turn down calculation . . . . .	4	Vibration resistance . . . . .	15
Registered trademarks . . . . .	5	Electromagnetic compatibility . . . . .	15
<b>Function and system design</b> . . . . .	<b>5</b>	<b>Process</b> . . . . .	<b>15</b>
Measuring principle - process pressure measurement . . . . .	5	Process temperature range for devices with ceramic process membrane . . . . .	15
Measuring system . . . . .	5	Pressure specifications . . . . .	16
Device features . . . . .	6	<b>Mechanical construction</b> . . . . .	<b>16</b>
Product design . . . . .	7	Design, dimensions . . . . .	16
System integration . . . . .	7	Electrical connection . . . . .	17
<b>Input</b> . . . . .	<b>7</b>	Housing . . . . .	17
Measured variable . . . . .	7	Process connections with internal, ceramic process membrane . . . . .	17
Measuring range . . . . .	8	Materials in contact with process . . . . .	21
<b>Output</b> . . . . .	<b>9</b>	Materials not in contact with process . . . . .	22
Output signal . . . . .	9	Cleaning . . . . .	22
Switching capacity . . . . .	9	<b>Operability</b> . . . . .	<b>23</b>
Signal range 4 to 20 mA . . . . .	9	IO-Link . . . . .	23
Load (for 4 to 20 mA devices ) . . . . .	9	<b>Certificates and approvals</b> . . . . .	<b>23</b>
Signal on alarm 4 to 20 mA . . . . .	9	CE mark . . . . .	23
Dead time, time constant . . . . .	10	RoHS . . . . .	23
Dynamic behavior . . . . .	10	RCM marking . . . . .	23
Dynamic behavior of switch output . . . . .	10	EAC conformity . . . . .	24
<b>Energy supply</b> . . . . .	<b>10</b>	Approval . . . . .	24
Terminal assignment . . . . .	10	Pressure Equipment Directive 2014/68/EU (PED) . . . . .	24
Supply voltage . . . . .	11	External standards and guidelines . . . . .	24
Current consumption and alarm signal . . . . .	11	CRN approval . . . . .	25
Power supply fault . . . . .	11	Calibration unit . . . . .	25
Electrical connection . . . . .	11	Calibration . . . . .	25
Residual ripple . . . . .	11	Inspection certificates . . . . .	25
Influence of power supply on the process value . . . . .	11	<b>Ordering information</b> . . . . .	<b>25</b>
Overvoltage protection . . . . .	11	Scope of delivery . . . . .	26
<b>Performance characteristics of the ceramic process membrane</b> . . . . .	<b>11</b>	<b>Accessories</b> . . . . .	<b>26</b>
Reference conditions . . . . .	11	M12 plug-in jacks . . . . .	26
Measuring uncertainty for small absolute pressure measuring ranges . . . . .	11	<b>Documentation</b> . . . . .	<b>27</b>
Resolution . . . . .	11	Field of activities . . . . .	27
Reference accuracy . . . . .	12	Technical Information . . . . .	27
Thermal change of the zero output and the output span . . . . .	12		
Long-term stability . . . . .	12		
Switch-on time . . . . .	12		
<b>Mounting</b> . . . . .	<b>12</b>		
Mounting requirements . . . . .	12		
Influence of orientation . . . . .	12		
Mounting location . . . . .	13		
Mounting instructions for oxygen applications . . . . .	14		

## About this document

<b>Document function</b>	The document contains all the technical data on the device and provides an overview of the accessories and other products that can be ordered for the device.
<b>Symbols</b>	<p><b>Safety symbols</b></p> <p> <b>DANGER</b></p> <p>This symbol alerts you to a dangerous situation. Failure to avoid this situation will result in serious or fatal injury.</p> <p> <b>WARNING</b></p> <p>This symbol alerts you to a dangerous situation. Failure to avoid this situation can result in serious or fatal injury.</p> <p> <b>CAUTION</b></p> <p>This symbol alerts you to a dangerous situation. Failure to avoid this situation can result in minor or medium injury.</p> <p><b>NOTICE</b></p> <p>This symbol contains information on procedures and other facts which do not result in personal injury.</p> <p><b>Electrical symbols</b></p> <p> Protective earth (PE) Ground terminals, which must be grounded prior to establishing any other connections. The ground terminals are located on the inside and outside of the device.</p> <p> Ground connection Grounded clamp, which is grounded via a grounding system.</p> <p><b>Tool symbols</b></p> <p> Open-ended wrench</p> <p><b>Symbols for certain types of Information</b></p> <p> Permitted Procedures, processes or actions that are permitted.</p> <p> Forbidden Procedures, processes or actions that are forbidden.</p> <p> Tip Indicates additional information</p> <p> Reference to documentation</p> <p> 1, 2, 3 Series of steps</p> <p>Reference to page: </p> <p>Result of an individual step: </p> <p><b>Symbols in graphics</b></p> <p><b>A, B, C ...</b> View</p> <p>1, 2, 3 ... Item numbers</p> <p> 1, 2, 3 Series of steps</p>
<b>Documentation</b>	<p>The following document types are available in the Downloads area of the Endress+Hauser website (<a href="http://www.endress.com/downloads">www.endress.com/downloads</a>):</p> <p> For an overview of the scope of the associated Technical Documentation, refer to the following:</p> <ul style="list-style-type: none"> <li>■ <i>W@M Device Viewer</i> (<a href="http://www.endress.com/deviceviewer">www.endress.com/deviceviewer</a>): Enter the serial number from the nameplate</li> <li>■ <i>Endress+Hauser Operations App</i>: Enter the serial number from the nameplate or scan the matrix code on the nameplate</li> </ul>

**Operating Instructions (BA)**

**Your reference guide**

These Operating Instructions contain all the information that is required in various phases of the life cycle of the device: from product identification, incoming acceptance and storage, to mounting, connection, operation and commissioning through to troubleshooting, maintenance and disposal.

**Brief Operating Instructions (KA)**

**Guide that takes you quickly to the 1st measured value**

The Brief Operating Instructions contain all the essential information from incoming acceptance to initial commissioning.

**Terms and abbreviations**

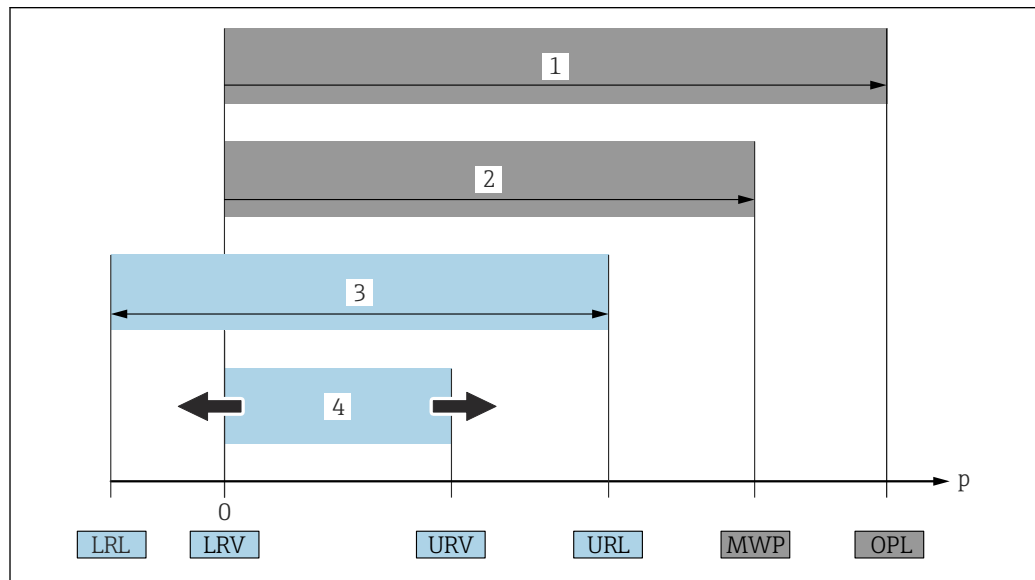

A0029505

- 1 OPL: The OPL (over pressure limit = sensor overload limit) for the measuring device depends on the lowest-rated element, with regard to pressure, of the selected components, i.e. the process connection has to be taken into consideration in addition to the measuring cell. Observe pressure-temperature dependency. The OPL may only be applied for a short period of time.
- 2 MWP: The MWP (maximum working pressure) for the sensors depends on the lowest-rated element, with regard to pressure, of the selected components, i.e. the process connection has to be taken into consideration in addition to the measuring cell. Observe pressure-temperature dependency. The maximum working pressure may be applied at the device for an unlimited period. The MWP can be found on the nameplate.
- 3 The maximum sensor measuring range corresponds to the span between the LRL and URL. This sensor measuring range is equivalent to the maximum calibratable/adjustable span.
- 4 The calibrated/adjusted span corresponds to the span between the LRV and URV. Factory setting: 0 to URL. Other calibrated spans can be ordered as customized spans.

p Pressure

LRL Lower range limit

URL Upper range limit

LRV Lower range value

URV Upper range value

TD Turn down Example - see the following section.

The turn down is preset in the factory and can be changed.

**Turn down calculation**

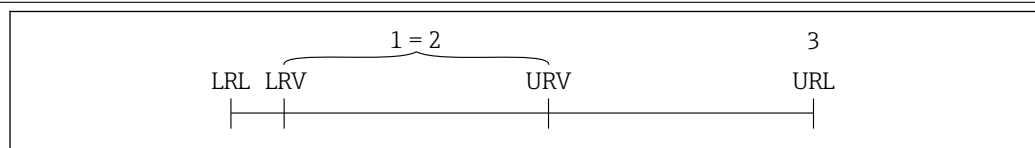

A0029545

1 Calibrated/adjusted span

2 Zero point-based span

3 Upper range limit

**Example**

- Sensor: 10 bar (150 psi)
- Upper range limit (URL) = 10 bar (150 psi)
- Turn down (TD):
- Calibrated/adjusted span: 0 to 5 bar (0 to 75 psi)
- Lower range value (LRV) = 0 bar (0 psi)
- Upper range value (URV) = 5 bar (75 psi)

$$TD = \frac{URL}{|URV - LRV|}$$

$$TD = \frac{10 \text{ bar (150 psi)}}{|5 \text{ bar (75 psi)} - 0 \text{ bar (0 psi)}|} = 2$$

In this example, the TD is 2:1.  
This span is based on the zero point.

**Registered trademarks**



is a registered trademark of the IO-Link Consortium.

## Function and system design

**Measuring principle - process pressure measurement**

**Devices with ceramic process membrane (Ceraphire®)**

The ceramic sensor is an oil-free sensor, i.e. the process pressure acts directly on the robust ceramic process membrane and causes it to deflect. A pressure-dependent change in capacitance is measured at the electrodes of the ceramic substrate and the process membrane. The measuring range is determined by the thickness of the ceramic process membrane.

**Advantages:**

- Guaranteed overload resistance up to 40 times the nominal pressure
- Thanks to ultrapure 99.9 % ceramic (Ceraphire®, see also "www.endress.com/ceraphire")
  - Extremely high chemical durability
  - High mechanical durability
- Can be used in absolute vacuum
- Small measuring ranges

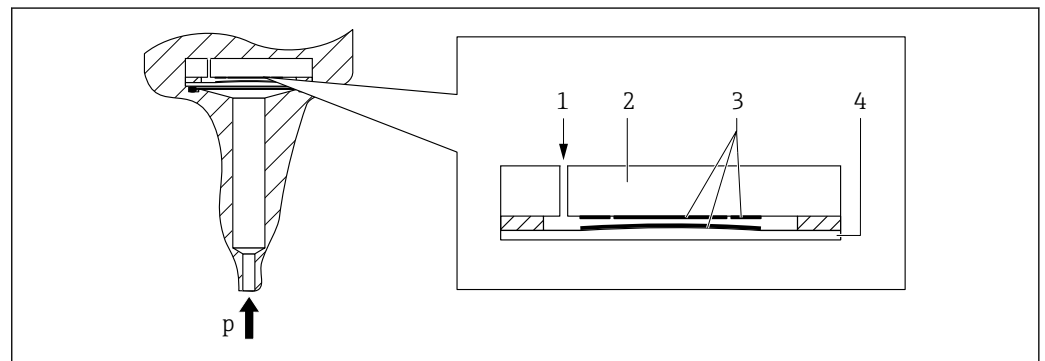

- 1 Air pressure (gauge pressure sensors)
- 2 Ceramic substrate
- 3 Electrodes
- 4 Ceramic process membrane

A0020465

**Measuring system**

A complete measuring system comprises:

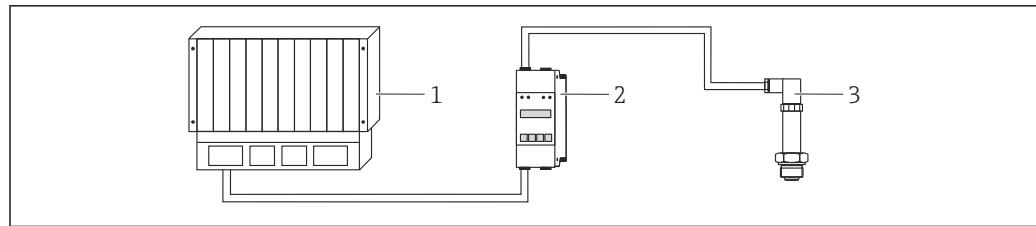

A0021926

- 1 PLC (programmable logic controller)
- 2 e.g. RN221N/RMA42 (if required)
- 3 Pressure transducer

## Device features

### Field of application

Gauge pressure and absolute pressure

### Process connections

- Thread ISO 228
- Thread DIN 13
- Thread ASME
- Thread JIS

### Measuring ranges

from -100 to +100 mbar (-1.5 to +1.5 psi) to -1 to +40 bar (-15 to +600 psi).

### OPL (depends on the measuring range)

Max. 0 to +60 bar (0 to +900 psi)

### MWP

Max. 1 to +40 bar (14.5 to +600 psi)

### Process temperature range (temperature at process connection)

-25 to +100 °C (-13 to +212 °F)

### Ambient temperature range

-40 to +70 °C (-40 to +158 °F)

### Reference accuracy

Up to 0.3 %, TD 5:1, for details, see "Reference accuracy" section.

### Supply voltage

Electronic version	Supply voltage
IO-Link	10 to 30 V <sub>DC</sub> IO-Link communication is guaranteed only if the supply voltage is at least 18 V.

### Output



- C/Q output for communication (SIO mode (switch output))
- Current output 4 to 20 mA

### Material

- Housing made of 316L (1.4404)
- Process connections made of 316L
- Process membrane made of Al<sub>2</sub>O<sub>3</sub> aluminum-oxide ceramic, (Ceraphire®), ultrapure 99.9 %

**Options**

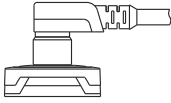
- Min. alarm current setting
- 3.1 Material certificates
- Calibration certificate
- Cleaned of oil and grease
- Cleaned for O<sub>2</sub> applications

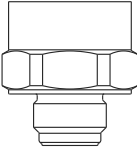
Overview	Item	Description
<p><b>C - 1</b></p>  <p>A0021987</p> <p><b>D</b></p>  <p><b>E</b></p>  <p>A0027226</p>	C - 1	M12 plug Housing cap made of plastic
	D E	Housing Process connection (sample illustration)

**System integration**

The device can be given a tag name (max. 32 alphanumeric characters).

Description	Option <sup>1)</sup>
Measuring point (TAG), see additional specifications	Z1

1) Product Configurator, order code for "Marking"

For devices with IO-Link, an IO-DD is available in the Downloads area of the Endress+Hauser website.

**Input**

**Measured variable**

**Measured process variable**

Gauge pressure or absolute pressure

**Calculated process variable**

Pressure

## Measuring range Ceramic process membrane

### Devices for gauge pressure measurement

Sensor	Maximum sensor measuring range		Smallest calibratable span <sup>1)</sup>	MWP	OPL	Factory settings <sup>2)</sup>	Option <sup>3)</sup>
	lower (LRL)	upper (URL)					
	[bar (psi)]	[bar (psi)]					
100 mbar (1.5 psi) <sup>4)</sup>	-0.1 (-1.5)	+0.1 (+1.5)	0.02 (0.3)	2.7 (40.5)	4 (60)	0 to 100 mbar (0 to 1.5 psi)	1C
250 mbar (4 psi) <sup>5)</sup>	-0.25 (-4)	+0.25 (+4)	0.05 (1)	3.3 (49.5)	5 (75)	0 to 250 mbar (0 to 4 psi)	1E
400 mbar (6 psi) <sup>6)</sup>	-0.4 (-6)	+0.4 (+6)	0.08 (1.2)	5.3 (79.5)	8 (120)	0 to 400 mbar (0 to 6 psi)	1F
1 bar (15 psi) <sup>6)</sup>	-1 (-15)	+1 (+15)	0.2 (3)	6.7 (100.5)	10 (150)	0 to 1 bar (0 to 15 psi)	1H
2 bar (30 psi) <sup>6)</sup>	-1 (-15)	+2 (+30)	0.4 (6)	12 (180)	18 (270)	0 to 2 bar (0 to 30 psi)	1K
4 bar (60 psi) <sup>6)</sup>	-1 (-15)	+4 (+60)	0.8 (12)	16.7 (250.5)	25 (375)	0 to 4 bar (0 to 60 psi)	1M
6 bar (90 psi) <sup>6)</sup>	-1 (-15)	+6 (+90)	2.4 (36)	26.7 (400.5)	40 (600)	0 to 6 bar (0 to 90 psi)	1N
10 bar (150 psi) <sup>6)</sup>	-1 (-15)	+10 (+150)	2 (30)	26.7 (400.5)	40 (600)	0 to 10 bar (0 to 150 psi)	1P
16 bar (240 psi) <sup>6)</sup>	-1 (-15)	+16 (+240)	6.4 (96)	40 (600)	60 (900)	0 to 16 bar (0 to 240 psi)	1Q
25 bar (375 psi) <sup>6)</sup>	-1 (-15)	+25 (+375)	10 (150)	40 (600)	60 (900)	0 to 25 bar (0 to 375 psi)	1R
40 bar (600 psi) <sup>6)</sup>	-1 (-15)	+40 (+600)	8 (120)	40 (600)	60 (900)	0 to 40 bar (0 to 600 psi)	1S

- 1) Highest turn down that can be set at the factory: 5:1. The turn down is preset and cannot be changed.
- 2) Other measuring ranges (e.g. -1 to +5 bar (-15 to 75 psi)) can be ordered with customer-specific settings (see the Product Configurator, order code for "Calibration; Unit" option "J"). It is possible to invert the output signal (LRV = 20 mA; URV = 4 mA). Prerequisite: URV < LRV
- 3) Product Configurator, order code for "Sensor range"
- 4) Vacuum resistance: 0.7 bar (10.5 psi) abs.
- 5) Vacuum resistance: 0.5 bar (7.5 psi) abs.
- 6) Vacuum resistance: 0 bar (0 psi) abs.

### Devices for absolute pressure measurement

Sensor	Maximum sensor measuring range		Smallest calibratable span <sup>1)</sup>	MWP	OPL	Factory settings <sup>2)</sup>	Option <sup>3)</sup>
	lower (LRL)	upper (URL)					
	[bar (psi)]	[bar (psi)]					
100 mbar (1.5 psi) <sup>4)</sup>	0	+0.1 (+1.5)	0.1 (1.5)	2.7 (40.5)	4 (60)	0 to 100 mbar (0 to 1.5 psi)	2C
250 mbar (4 psi) <sup>4)</sup>	0	+0.25 (+4)	0.25 (4)	3.3 (49.5)	5 (75)	0 to 250 mbar (0 to 4 psi)	2E
400 mbar (6 psi) <sup>4)</sup>	0	+0.4 (+6)	0.4 (6)	5.3 (79.5)	8 (120)	0 to 400 mbar (0 to 6 psi)	2F
1 bar (15 psi) <sup>4)</sup>	0	+1 (+15)	0.4 (6)	6.7 (100.5)	10 (150)	0 to 1 bar (0 to 15 psi)	2H
2 bar (30 psi) <sup>4)</sup>	0	+2 (+30)	0.4 (6)	12 (180)	18 (270)	0 to 2 bar (0 to 30 psi)	2K
4 bar (60 psi) <sup>4)</sup>	0	+4 (+60)	0.8 (12)	16.7 (250.5)	25 (375)	0 to 4 bar (0 to 60 psi)	2M
10 bar (150 psi) <sup>4)</sup>	0	+10 (+150)	2 (30)	26.7 (400.5)	40 (600)	0 to 10 bar (0 to 150 psi)	2P
40 bar (600 psi) <sup>4)</sup>	0	+40 (+600)	8 (120)	40 (600)	60 (900)	0 to 40 bar (0 to 600 psi)	2S

- 1) Highest turn down that can be set at the factory: 5:1. The turn down is preset and cannot be changed.
- 2) Other measuring ranges (e.g. -1 to +5 bar (-15 to 75 psi)) can be ordered with customer-specific settings (see the Product Configurator, order code for "Calibration; Unit" option "J"). It is possible to invert the output signal (LRV = 20 mA; URV = 4 mA). Prerequisite: URV < LRV
- 3) Product Configurator, order code for "Sensor range"
- 4) Vacuum resistance: 0 bar (0 psi) abs.

*Maximum turn down which can be ordered for absolute pressure and gauge pressure sensors*

Devices for gauge pressure measurement

- 6 bar (90 psi), 16 bar (240 psi), 25 bar (375 psi): TD 1:1 to TD 2.5:1
- All other measuring ranges: TD 1:1 to TD 5:1

Devices for absolute pressure measurement

- 100 mbar (1.5 psi), 250 mbar (4 psi), 400 mbar (6 psi): TD 1:1
- 1 bar (15 psi): TD 1:1 to TD 2.5:1
- All other measuring ranges: TD 1:1 to TD 5:1

## Output

Output signal	Description	Option <sup>1)</sup>
	IO-Link (SSP Ed. 2 V1.1), 4 to 20 mA	A

1) Product Configurator, order code for "Output"

<b>Switching capacity</b>	<ul style="list-style-type: none"> <li>▪ Switch status ON: <math>I_a \leq 200 \text{ mA}</math> <sup>1) 2)</sup>; Switch status OFF: <math>I_a \leq 1 \text{ mA}</math></li> <li>▪ Switch cycles: &gt;10,000,000</li> <li>▪ Voltage drop PNP: <math>\leq 2 \text{ V}</math></li> <li>▪ Overload protection: Automatic load testing of switching current;                             <ul style="list-style-type: none"> <li>▪ Max. capacitance load: 1 <math>\mu\text{F}</math> at max. supply voltage (without resistive load)</li> <li>▪ Max. cycle duration: 0.5 s; min. <math>t_{\text{on}}</math>: 40 <math>\mu\text{s}</math></li> <li>▪ Periodic disconnection from protective circuit in the event of overcurrent (<math>f = 2 \text{ Hz}</math>) and "F804" displayed</li> </ul> </li> </ul>
---------------------------	-------------------------------------------------------------------------------------------------------------------------------------------------------------------------------------------------------------------------------------------------------------------------------------------------------------------------------------------------------------------------------------------------------------------------------------------------------------------------------------------------------------------------------------------------------------------------------------------------------------------------------------------------------------------------------------------------------------------------------------------------------------------------------------------------------

<b>Signal range 4 to 20 mA</b>	3.8 to 20.5 mA
--------------------------------	----------------

**Load (for 4 to 20 mA devices )** In order to guarantee sufficient terminal voltage, a maximum load resistance  $R_L$  (including line resistance) must not be exceeded depending on the supply voltage  $U_B$  of the supply unit.

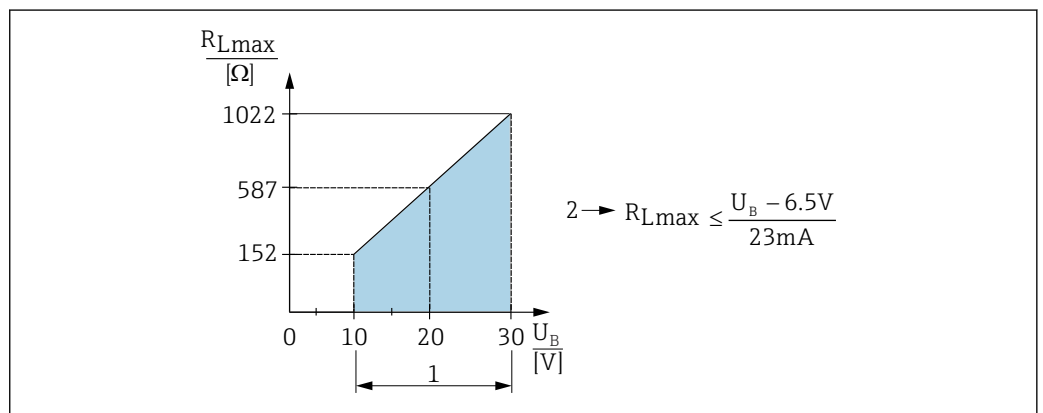

- 1 Power supply 10 to 30  $V_{DC}$   
 2  $R_{Lmax}$  Maximum load resistance  
 $U_B$  Supply voltage

If load is too great:

- Failure current is indicated and "S803" displayed (indication: MIN alarm current)
- Periodic checking to establish if it is possible to quit fault state
- In order to guarantee sufficient terminal voltage, a maximum load resistance  $R_L$  (including line resistance) must not be exceeded depending on the supply voltage  $U_B$  of the supply unit.

<b>Signal on alarm 4 to 20 mA</b>	The response of the output to error is regulated in accordance with NAMUR NE43. Factory setting MAX alarm: >21 mA
-----------------------------------	----------------------------------------------------------------------------------------------------------------------

- 1) For the switch output 1 x PNP + 4 to 20 mA output 100 mA can be guaranteed over the entire temperature range. For lower ambient temperatures, higher currents are possible but cannot be guaranteed. Typical value at 20 °C (68 °F) approx. 200 mA. For the switch output "1 x PNP", 200 mA can be guaranteed over the entire temperature range.
- 2) Larger currents are supported, thus deviating from the IO-Link standard.

**Alarm current**

Description	Option
Min. alarm current set	IA <sup>1)</sup>

1) Product Configurator, order code for "Service"

**Dead time, time constant**

Presentation of the dead time and the time constant:

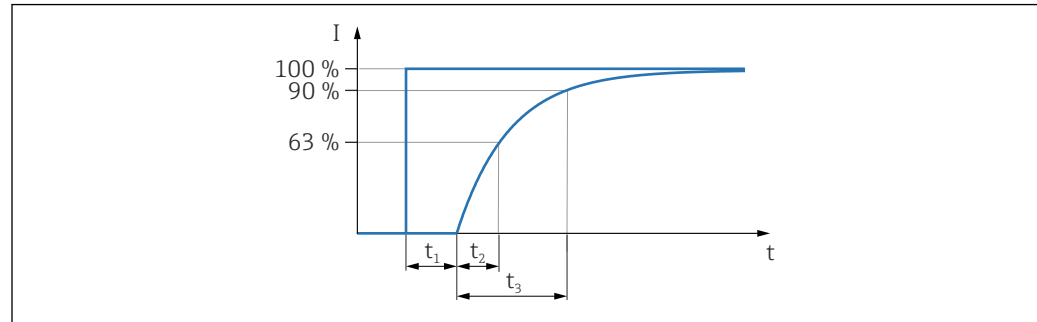

A0019786

**Dynamic behavior**

Dead time ( $t_1$ ) [ms]	Time constant (T63), $t_2$ [ms]	Time constant (T90), $t_3$ [ms]
7 ms	11 ms	16 ms

**Dynamic behavior of switch output**

Response time  $\leq 20$  ms

**Energy supply**

**⚠ WARNING**

**An incorrect connection compromises electrical safety!**

- ▶ A suitable circuit breaker must be provided for the device in accordance with IEC/EN 61010.
- ▶ **Non-hazardous area:** To meet device safety specifications according to the IEC/EN 61010 standard, the installation must ensure that the maximum current is limited to 500 mA.
- ▶ When using the measuring device in hazardous areas, installation must also comply with the applicable national standards and regulations and the Safety Instructions or Installation or Control Drawings.
- ▶ All explosion protection data are provided in separate Ex documentation, which is available on request. The Ex documentation is supplied as standard with all devices approved for use in explosion hazardous areas.
- ▶ Protective circuits against reverse polarity are integrated.

**Terminal assignment**

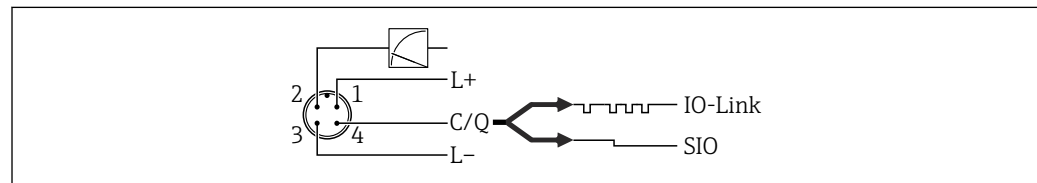

A0034006

- 1 M12 plug
- 1 Supply voltage +
- 2 4-20 mA
- 3 Supply voltage -
- 4 C/Q (IO-Link communication or SIO mode)

<b>Supply voltage</b>	<b>Electronic version</b>	<b>Supply voltage</b>
	IO-Link	10 to 30 V <sub>DC</sub> IO-Link communication is guaranteed only if the supply voltage is at least 18 V.

<b>Current consumption and alarm signal</b>	<b>Electronic version</b>	<b>Current consumption</b>	<b>Alarm signal<sup>1)</sup></b>
	IO-Link	Maximum current consumption: ≤ 300 mA	

1) For MAX alarm (factory setting)

<b>Power supply fault</b>	<ul style="list-style-type: none"> <li>■ Behavior in the event of overvoltage (&gt;30 V): The device works continuously up to 34 V DC without damage. If the supply voltage is exceeded, the specified characteristics are no longer guaranteed.</li> <li>■ Behavior in the event of undervoltage: If the supply voltage falls below the minimum value, the device switches off in a defined manner.</li> </ul>
---------------------------	-------------------------------------------------------------------------------------------------------------------------------------------------------------------------------------------------------------------------------------------------------------------------------------------------------------------------------------------------------------------------------------------------------------------------

<b>Electrical connection</b>	<b>Degree of protection</b>						
	<table border="1"> <thead> <tr> <th>Connection</th> <th>Degree of protection</th> <th>Option<sup>1)</sup></th> </tr> </thead> <tbody> <tr> <td>M12 plug</td> <td>IP65/67 NEMA Type 4X enclosure</td> <td>M</td> </tr> </tbody> </table>	Connection	Degree of protection	Option <sup>1)</sup>	M12 plug	IP65/67 NEMA Type 4X enclosure	M
Connection	Degree of protection	Option <sup>1)</sup>					
M12 plug	IP65/67 NEMA Type 4X enclosure	M					

1) Product Configurator, order code for "Electrical connection"

<b>Residual ripple</b>	The device operates within the reference accuracy up to ±5 % of the residual ripple of the supply voltage, within the permitted voltage range.
------------------------	------------------------------------------------------------------------------------------------------------------------------------------------

<b>Influence of power supply on the process value</b>	≤0.005 % of URV/1 V
-------------------------------------------------------	---------------------

<b>Overvoltage protection</b>	The device does not contain any special elements to protect against overvoltage ("wire to ground"). Nevertheless the requirements of the applicable EMC standard EN 61000-4-5 (testing voltage 1kV EMC wire/ground) are met.
-------------------------------	------------------------------------------------------------------------------------------------------------------------------------------------------------------------------------------------------------------------------

## Performance characteristics of the ceramic process membrane

<b>Reference conditions</b>	<ul style="list-style-type: none"> <li>■ As per IEC 60770</li> <li>■ Ambient temperature T<sub>A</sub> = constant, in the range of: +21 to +33 °C (+70 to +91 °F)</li> <li>■ Humidity φ = constant, in the range of 5 to 80 % rH</li> <li>■ Ambient pressure p<sub>A</sub> = constant, in the range of: 860 to 1 060 mbar (12.47 to 15.37 psi)</li> <li>■ Position of the measuring cell = constant, in the range of: horizontal ±1°</li> <li>■ Zero based span</li> <li>■ Material of process membrane: Al<sub>2</sub>O<sub>3</sub> (aluminum-oxide ceramic, Ceraphire®)</li> <li>■ Supply voltage: 24 V DC ±3 V DC</li> <li>■ Load: 320 Ω (at 4 to 20 mA output)</li> </ul>
-----------------------------	-------------------------------------------------------------------------------------------------------------------------------------------------------------------------------------------------------------------------------------------------------------------------------------------------------------------------------------------------------------------------------------------------------------------------------------------------------------------------------------------------------------------------------------------------------------------------------------------------------------------------------------------------------------------------------

<b>Measuring uncertainty for small absolute pressure measuring ranges</b>	<p><b>The smallest extended uncertainty of measurement that can be delivered by our standards is</b></p> <ul style="list-style-type: none"> <li>■ in the range of 1 to 30 mbar (0.0145 to 0.435 psi): 0.4 % of reading</li> <li>■ in the range of &lt; 1 mbar (0.0145 psi): 1 % of reading.</li> </ul>
---------------------------------------------------------------------------	--------------------------------------------------------------------------------------------------------------------------------------------------------------------------------------------------------------------------------------------------------------------------------------------------------

<b>Resolution</b>	Current output: min. 1.6 µA
-------------------	-----------------------------

**Reference accuracy**

The reference accuracy contains the non-linearity [DIN EN 61298-2 3.11] including the pressure hysteresis [DIN EN 61298-23.13] and non-repeatability [DIN EN 61298-2 3.11] in accordance with the limit point method as per [DIN EN 60770].

% of the calibrated span to the maximum turn down		
Reference accuracy	Non-linearity <sup>1)</sup>	Non-repeatability
±0.3	±0.1	±0.1

- 1) The non-linearity for the 40 bar (600 psi) sensor can be up to ± 0.15% of the calibrated span up to the maximum turn down.

Overview of the turn down ranges →  7

Measuring ranges	Turn down	% of URL
100 mbar (1.5 psi) to 40 bar (600 psi)	1:1 to TD 5:1	±0.5
		±0.3 <sup>1)</sup>

- 1) For the 100 mbar (1.5 psi) and 250 mbar (4 psi) measuring ranges, the following applies: In the event of heat effects on the initial reference conditions, an additional deviation of max. 0.3 mbar (4.5 psi) from the zero point or the output span is possible.

**Thermal change of the zero output and the output span**

Measuring cell	-20 to +85 °C (-4 to +185 °F)	-40 to -20 °C (-40 to -4 °F) +85 to +100 °C (+185 to +212 °F)
	% of the calibrated span for TD 1:1	
<1 bar (15 psi)	<1	<1.2
≥1 bar (15 psi)	<0.8	<1

**Long-term stability**

1 year	5 years	8 years
% of the URL		
±0.2	±0.4	±0.45

**Switch-on time**

≤2 s

For small measuring ranges, pay attention to the thermal compensation effects.

## Mounting

**Mounting requirements**

- No moisture may enter the housing when installing or operating the device, or when establishing the electrical connection.
- Point the cable and plug downwards where possible to prevent moisture from entering (e.g. rain or condensation water).

**Influence of orientation**

Any orientation is possible. However, the orientation may cause a zero point shift, i.e. the measured value does not show zero when the vessel is empty or partially full.

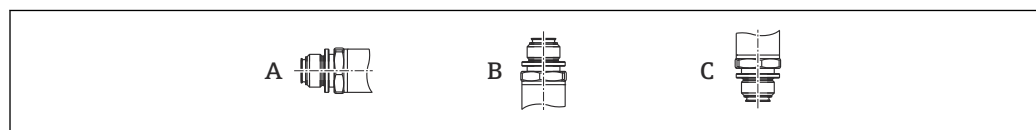

A0024708

Type	Process membrane axis is horizontal (A)	Process membrane pointing upwards (B)	Process membrane pointing downwards (C)
< 1 bar (15 psi)	Calibration position, no effect	Up to +0.3 mbar (+0.0044 psi)	Up to -0.3 mbar (-0.0044 psi)
> 1 bar (15 psi)	Calibration position, no effect	Up to +3 mbar (+0.0435 psi)	Up to -3 mbar (-0.0435 psi)

**Mounting location**

**Pressure measurement**

*Pressure measurement in gases*

Mount the device with the shutoff device above the tapping point to allow any condensate to flow into the process.

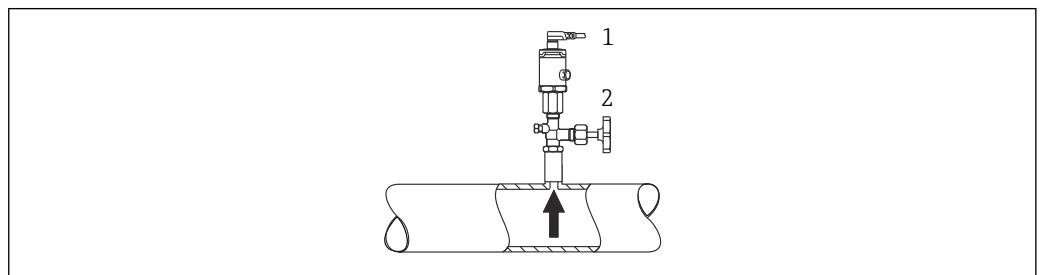

A0021904

- 1 Device
- 2 Shutoff device

*Pressure measurement in vapors*

For pressure measurement in vapors, use a siphon. The siphon reduces the temperature to almost ambient temperature. Mount the device with the shutoff device at the same level as the tapping point.

Advantage:

only minor/negligible heat effects on the device.

Note the max. permitted ambient temperature of the transmitter!

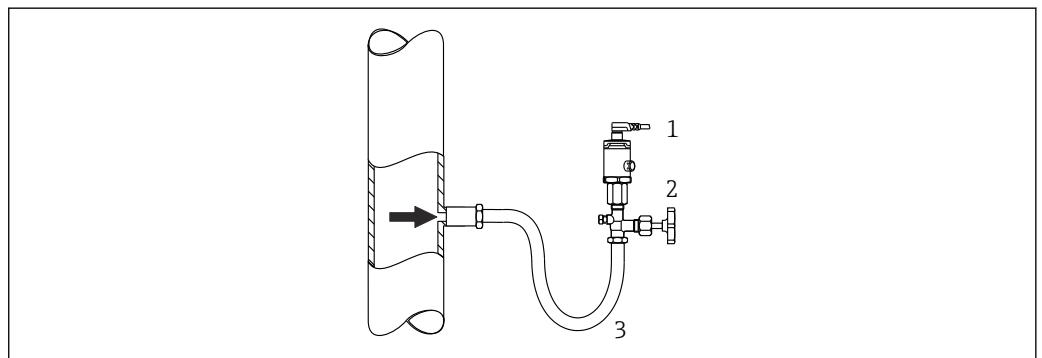

A0024395

- 1 Device
- 2 Shutoff device
- 3 Siphon

*Pressure measurement in liquids*

Mount the device with the shutoff device at the same level as or below the tapping point.

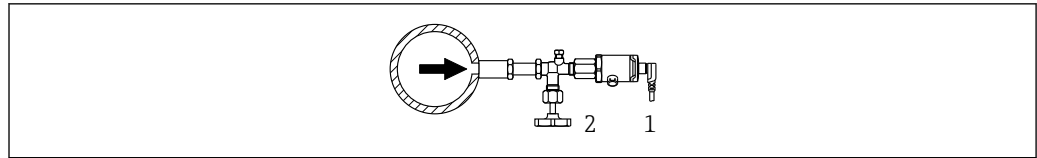

A0024399

- 1 Device
- 2 Shutoff device

### Level measurement

- Always install the device below the lowest measuring point.
- Do not install the device at the following positions:
  - In the filling curtain
  - In the tank outlet
  - In the suction area of a pump
  - At a point in the tank which could be affected by pressure pulses from the agitator

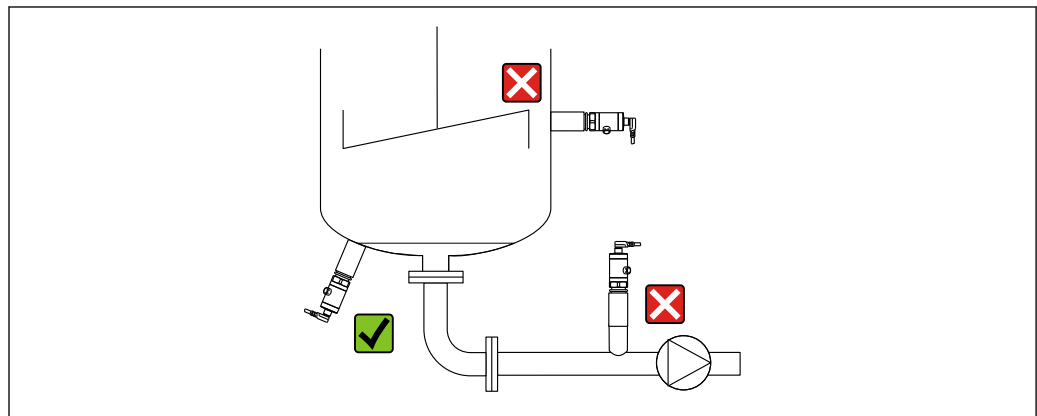

A0024405

### Mounting instructions for oxygen applications

Oxygen and other gases can react explosively to oils, grease and plastics, such that, among other things, the following precautions must be taken:

- All components of the system, such as measuring devices, must be cleaned in accordance with the BAM requirements.
- Depending on the materials used, a certain maximum temperature and a maximum pressure must not be exceeded for oxygen applications.
- The following table lists devices (devices only, not accessories or enclosed accessories), which are suitable for gaseous oxygen applications.

$p_{max}$ for oxygen applications	$T_{max}$ for oxygen applications	Option <sup>1)</sup>
40 bar (600 psi)	-10 to +60 °C (+14 to +140 °F)	HB

1) Product Configurator, order code for "Service"

## Environment

Ambient temperature range    Ambient temperature range <sup>3)</sup>  
 -40 to +70 °C (-40 to +158 °F)

Storage temperature range    -40 to +85 °C (-40 to +185 °F)

3) Exception: the following cable is designed for an ambient temperature range of -25 to +70 °C (-13 to +158 °F): Product Configurator, order code for "Accessory enclosed" option "RZ".

Climate class	Climate class	Note
	Class 3K5	Air temperature: -5 to +45 °C (+23 to +113 °F), relative humidity: 4 to 95 % satisfied according to IEC 721-3-3 (condensation not possible)

Degree of protection	Connection	Degree of protection	Option <sup>1)</sup>
	M12 plug	IP65/67 NEMA Type 4X enclosure	M

1) Product Configurator, order code for "Electrical connection"

Vibration resistance	Test standard	Vibration resistance
	IEC 60068-2-64:2008	Guaranteed for 5 to 2000Hz: 0.05g <sup>2</sup> /Hz

**Electromagnetic compatibility**

- Interference emission as per EN 61326-1 equipment B
- Interference immunity as per EN 61326-1 (industrial environment)  
For intended use, the switch output can switch to the communication mode for 0.2 s in the event of transient faults
- Maximum deviation: 1.5% with TD 1:1

For more details, please refer to the Declaration of Conformity.

## Process

**Process temperature range for devices with ceramic process membrane**

- -25 to +100 °C (-13 to +212 °F)
- For oxygen applications -10 to +60 °C (+14 to +140 °F)
- For saturated steam applications, use a device with a metallic process membrane, or provide a siphon for temperature isolation when installing.
- Pay attention to the process temperature range of the seal. See also the following table.

Seal	Notes	Process temperature range	Option
FKM	-	-20 to +100 °C (-4 to +212 °F)	A <sup>1)</sup>
FKM	Cleaned for oxygen application	-10 to +60 °C (+14 to +140 °F)	A <sup>1)</sup> and HB <sup>2)</sup>
EPDM 70	-	-25 to +100 °C (-13 to +212 °F)	J <sup>1)</sup>

- 1) Product Configurator, order code for "Seal"  
2) Product Configurator, order code for "Service"

**Applications with changes in temperature**

Frequent extreme changes in temperatures can temporarily cause measuring errors. Internal temperature compensation occurs more quickly the smaller the change in temperature and the longer the time interval involved.

For further information please contact your local Endress+Hauser Sales Center.

## Pressure specifications



**The maximum pressure for the measuring device depends on the lowest-rated element with regard to pressure.**

- ▶ For pressure specifications, see the "Measuring range" section and the "Mechanical construction" section.
- ▶ The Pressure Equipment Directive (2014/68/EU) uses the abbreviation "PS". The abbreviation "PS" corresponds to the MWP (maximum working pressure) of the measuring device.
- ▶ MWP (maximum working pressure): The MWP (maximum working pressure) is specified on the nameplate. This value is based on a reference temperature of +20 °C (+68 °F) and may be applied to the device for an unlimited period of time. Observe the temperature dependency of the MWP.
- ▶ OPL (over pressure limit): The test pressure corresponds to the over pressure limit of the sensor and may only be applied temporarily to ensure that the measurement is within the specifications and no permanent damage develops. In the case of sensor range and process connections where the over pressure limit (OPL) of the process connection is smaller than the nominal value of the sensor, the device is set at the factory, at the very maximum, to the OPL value of the process connection. If you want to use the entire sensor range, select a process connection with a higher OPL value.
- ▶ Oxygen applications: In oxygen applications, the values for  $p_{\max}$  and  $T_{\max}$  for oxygen applications may not be exceeded.
- ▶ Devices with ceramic process membrane: Avoid steam hammering! Steam hammering can cause zero point drift. Recommendation: Residue (water droplets or condensation) may remain on the process membrane following CIP cleaning and can result in local steam hammering the next time steam cleaning takes place. In practice, drying the process membrane (e.g. by blowing off excess moisture) has proven to be a successful way of avoiding steam hammering.

## Mechanical construction



For the dimensions, see the Product Configurator: [www.endress.com](http://www.endress.com)

Search for product → click "Configuration" to the right of the product image → after configuration click "CAD"

The following dimensions are rounded values. For this reason, they may deviate slightly from the dimensions given on [www.endress.com](http://www.endress.com).

## Design, dimensions

### Device height

**The device height is calculated from**

- the height of the electrical connection
- the height of the housing and
- the height of the individual process connection.

The individual heights of the components are listed in the following sections. To calculate the device height simply add up the individual heights of the components. If necessary, the installation clearance (the space used to install the device) must also be taken into account. You can use the following table for this:

Section	Height	Example
Electrical connection	(A)	
Housing height	(B)	
Process connection height	(C)	
Installation clearance	(D)	

A0027252

**Electrical connection**

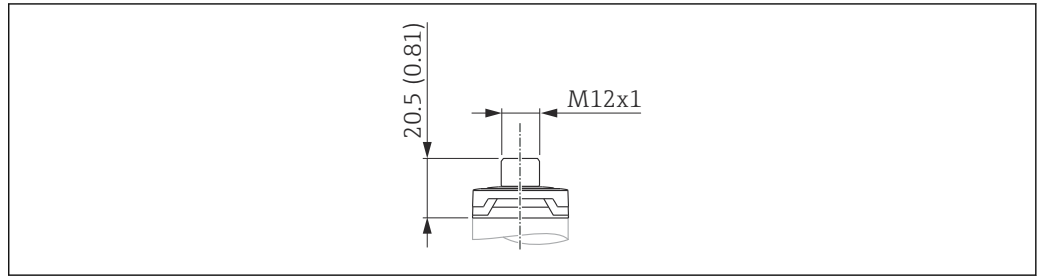

A0024426

2 M12 plug IP65/67. Unit of measurement mm (in)

Material	Weight kg (lbs)	Option <sup>1)</sup>
Housing cap made of plastic	0.012 (0.03)	M Plug connector with cable can be ordered as an accessory

1) Product Configurator, order code for "Electrical connection"

**Housing**

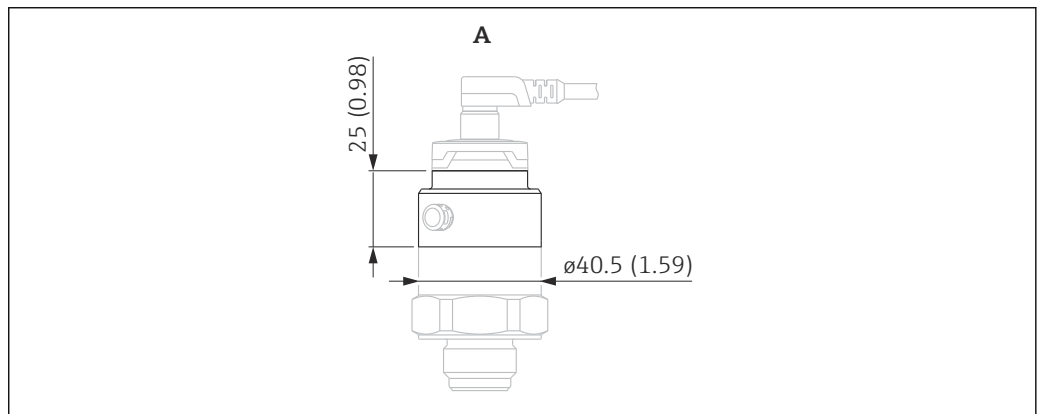

A0022243

Item	Material	Weight kg (lbs)
A	Stainless steel 316L	0.150 (0.33)

**Process connections with internal, ceramic process membrane**

**Thread ISO 228 G**

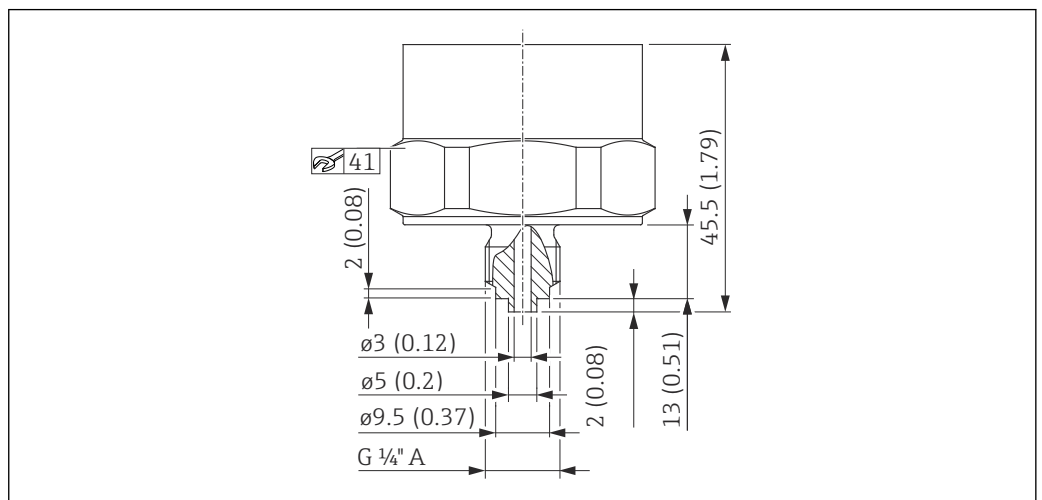

A0022236

3 Thread ISO 228 G 1/4" A, EN 837. Unit of measurement mm (in)

Material	Weight	Option <sup>1)</sup>
	kg (lbs)	
316L	0.160 (0.35)	WTJ

1) Product Configurator, order code for "Process connection"

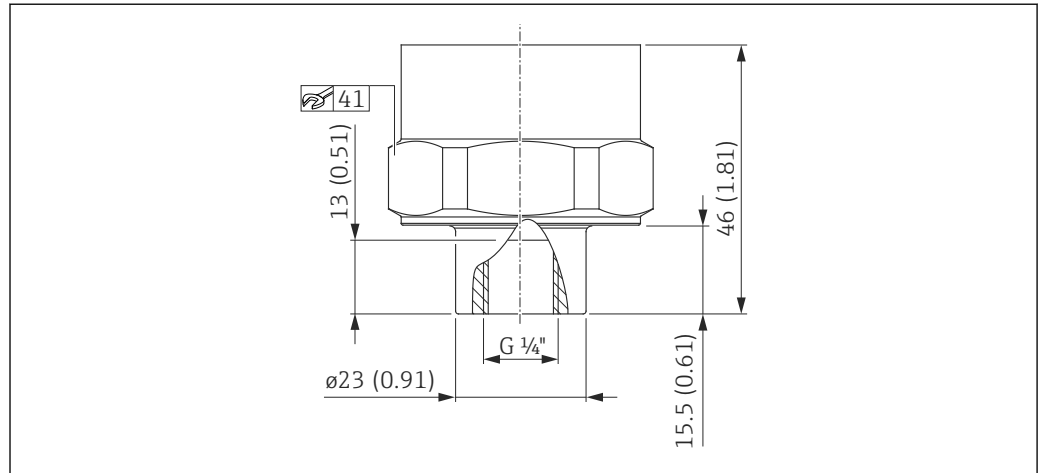

A0022237

4 Thread ISO 228 G 1/4" (female). Unit of measurement mm (in)

Material	Weight	Option <sup>1)</sup>
	kg (lbs)	
316L	0.180 (0.40)	WAJ

1) Product Configurator, order code for "Process connection"

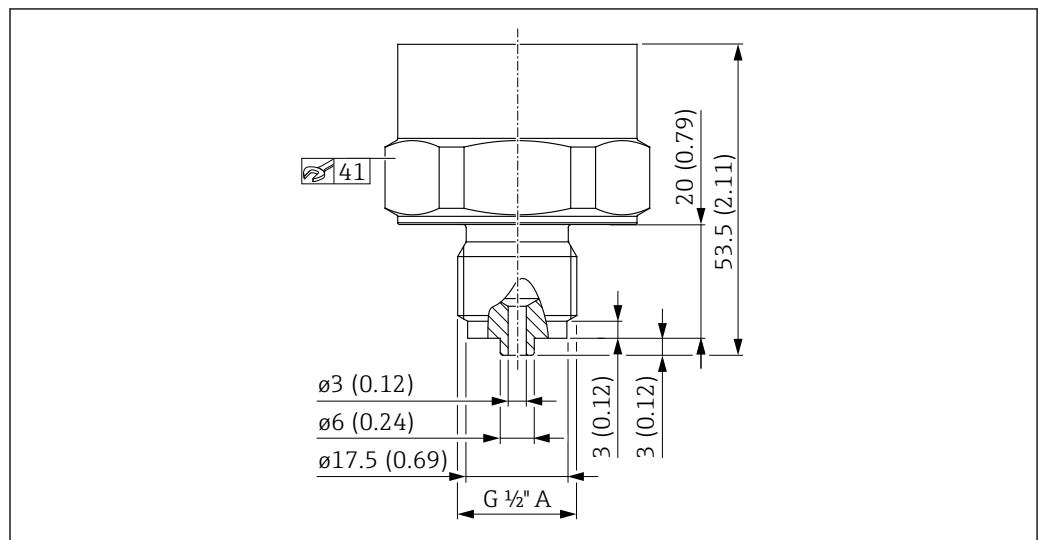

A0022238

5 Thread ISO 228 G 1/2" A, EN 837. Unit of measurement mm (in)

Material	Weight	Option <sup>1)</sup>
	kg (lbs)	
316L	0.180 (0.40)	WBJ

1) Product Configurator, order code for "Process connection"

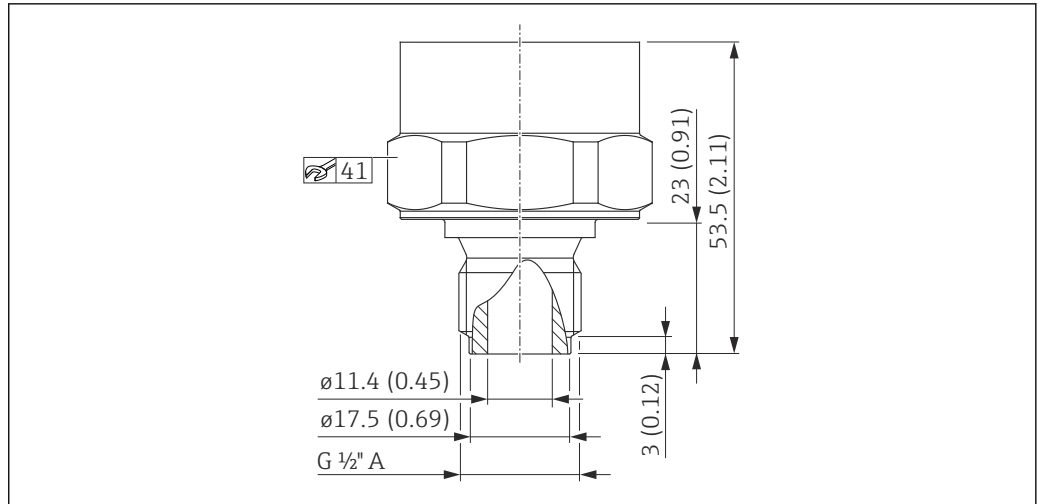

A0022239

6 Thread ISO 228 G 1/2" A, bore 11.4 mm (0.45 in). Unit of measurement mm (in)

Material	Weight	Option <sup>1)</sup>
	kg (lbs)	
316L	0.180 (0.40)	WWJ

1) Product Configurator, order code for "Process connection"

**Thread ASME**

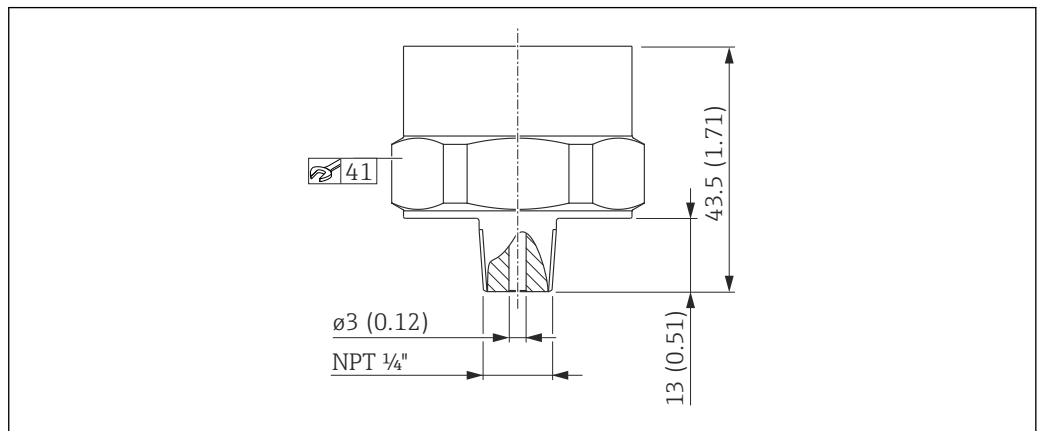

A0022242

7 ASME 1/4" MNPT, bore 3 mm (0.12 in). Unit of measurement mm (in)

Material	Weight	Approval	Option <sup>1)</sup>
	kg (lbs)		
316L	0.160 (0.35)	CRN	VUJ

1) Product Configurator, order code for "Process connection"

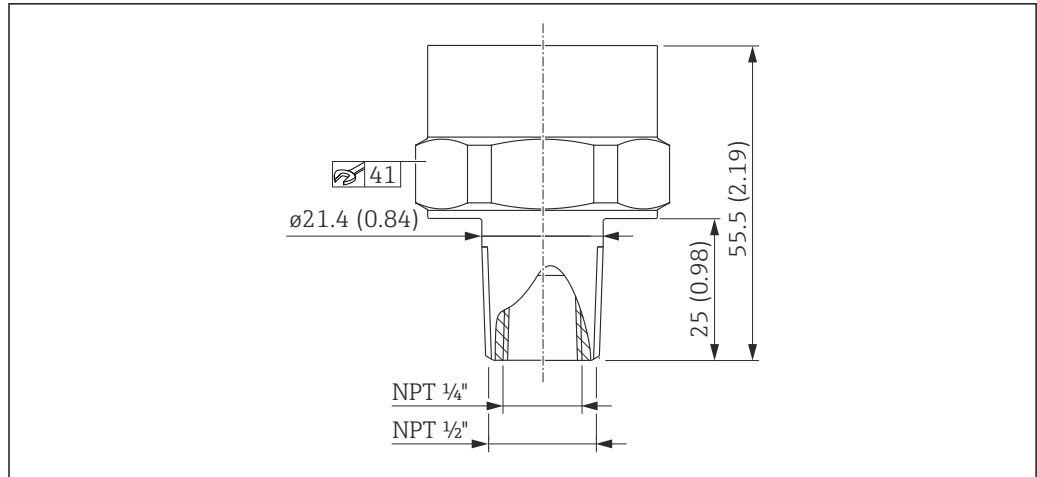

A0022241

8 ASME 1/2" MNPT, 1/4" FNPT (female). Unit of measurement mm (in)

Material	Weight	Approval	Option <sup>1)</sup>
	kg (lbs)		
316L	0.190 (0.42)	CRN	VXJ

1) Product Configurator, order code for "Process connection"

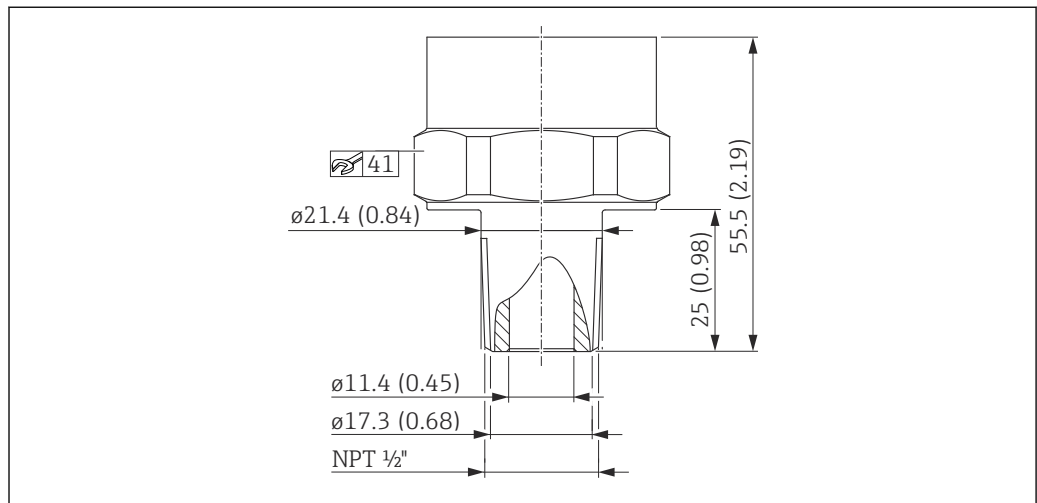

A0022240

9 ASME 1/2" MNPT, bore 11.4 mm (0.45 in). Unit of measurement mm (in)

Material	Weight	Approval	Option <sup>1)</sup>
	kg (lbs)		
316L	0.190 (0.42)	CRN	VWJ

1) Product Configurator, order code for "Process connection"

**Thread DIN13**

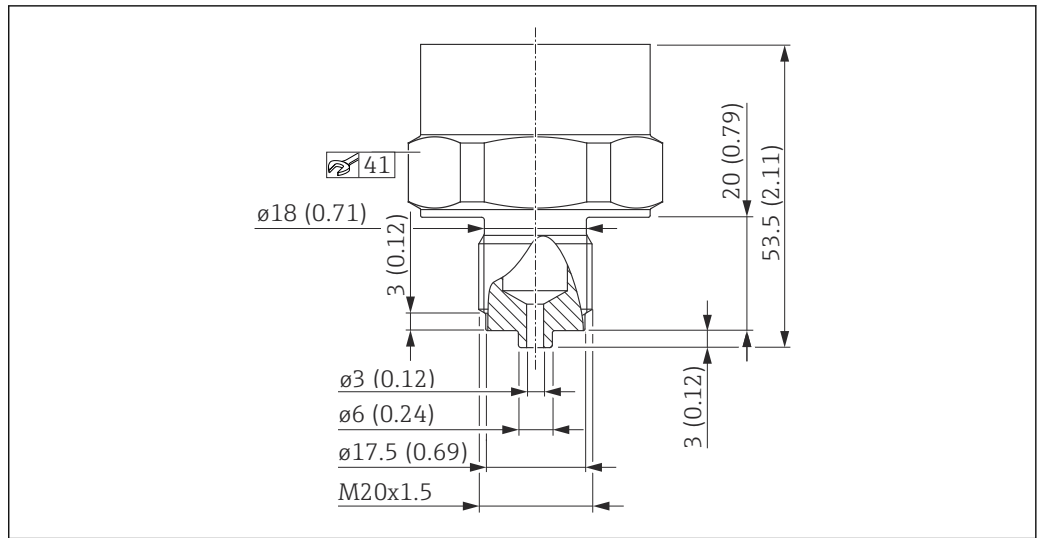

10 DIN 13 M20 x 1.5, EN 837, bore 3 mm (0.12 in)

Material	Weight	Option <sup>1)</sup>
	kg (lbs)	
316L	0.180 (0.40)	X4J

1) Product Configurator, order code for "Process connection"

**Thread JIS B0203**

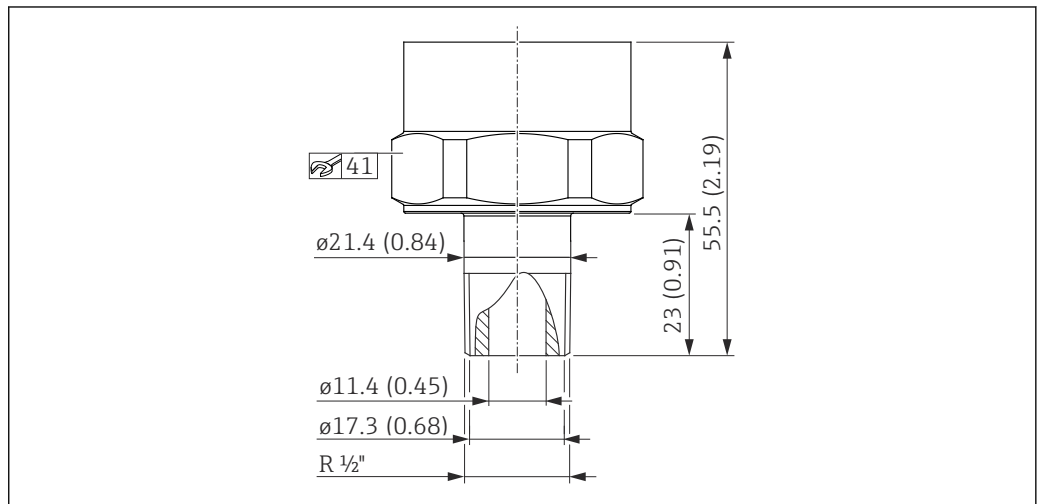

11 JIS B0203 R 1/2 (male). Unit of measurement mm (in)

Material	Weight	Option <sup>1)</sup>
	kg (lbs)	
316L	0.180 (0.40)	ZJJ

1) Product Configurator, order code for "Process connection"

**Materials in contact with process**

 Device components in contact with the process are listed in the "Mechanical construction" and "Ordering information" sections.

**TSE Certificate of Suitability**

The following applies to all device components in contact with the process:

- They do not contain any materials derived from animals.
- No additives or operating materials derived from animals are used in production or processing.

**Process connections**

Endress+Hauser supplies a threaded connection made of stainless steel in accordance with AISI 316L (DIN/ EN material number 1.4404 or 1.4435). With regard to their stability-temperature property, the materials 1.4404 and 1.4435 are grouped together under 13E0 in EN 1092-1: 2001 Tab. 18. The chemical composition of the two materials can be identical.

**Process membrane**

Ceramic process membrane

- Al<sub>2</sub>O<sub>3</sub> aluminum-oxide ceramic, Ceraphire® FDA, ultrapure 99.9 % (see also [www.endress.com/ceraphire](http://www.endress.com/ceraphire))
- The US Food & Drug Administration (FDA) has no objections to the use of ceramics made from aluminum oxide as a surface material in contact with foodstuffs. This declaration is based on the FDA certificates of our ceramic suppliers.

**Seals**

See the specific process connection.

**Materials not in contact with process**

**Housing**

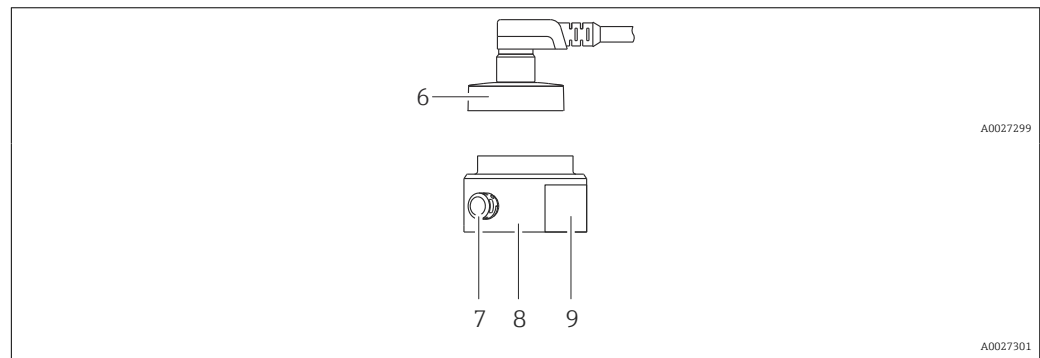

Item number	Component	Material
6	M12 plug	316L (1.4404)
7	Pressure compensation element	Standard: PBT/PC
8	Housing	316L (1.4404)
9	Nameplates	Plastic foil (attached to housing) or directly lasered onto the housing

**Cleaning**

Description	Option <sup>1)</sup>
Cleaned of oil and grease	HA
Cleaned for oxygen application	HB

1) Product Configurator, order code for "Service"

## Operability

### IO-Link

#### Operating concept for devices with IO-Link

*Operator-oriented menu structure for user-specific tasks*

*Reliable operation*

Operation in the following languages:

Via IO-Link: English

*Efficient diagnostics increase measurement reliability*

- Remedial measures
- Simulation options

#### IO-Link information

IO-Link is a point-to-point connection for communication between the measuring device and an IO-Link master. The measuring device features an IO-Link communication interface type 2 with a second IO function on pin 4. This requires an IO-Link-compatible assembly (IO-Link master) for operation. The IO-Link communication interface enables direct access to the process and diagnostic data. It also provides the option of configuring the measuring device while in operation.

Physical layer, the measuring device supports the following features:

- IO-Link specification: Version 1.1
- IO-Link Smart Sensor Profile 2nd Edition
- SIO mode: Yes
- Speed: COM2; 38.4 kBaud
- Minimum cycle time: 2.5 msec.
- Process data width: 48 bits (Float32+14-bit vendor-spec. + 2 bits SSC)
- IO-Link data storage: Yes
- Block configuration: Yes

#### IO-Link download

<http://www.endress.com/download>

- Select "Software" as the media type.
- Select "Device Driver" as the software type.  
Select IO-Link (IODD).
- In the "Text Search" field enter the device name.

<https://ioddfinder.io-link.com/>

Search by

- Manufacturer
- Article number
- Product type

## Certificates and approvals

### CE mark

The measuring system meets the legal requirements of the applicable EC guidelines. These are listed in the corresponding EC Declaration of Conformity together with the standards applied.

Endress+Hauser confirms successful testing of the device by affixing to it the CE mark.

### RoHS

The measuring system complies with the substance restrictions of the Restriction on Hazardous Substances Directive 2011/65/EU (RoHS 2).

### RCM marking

The supplied product or measuring system meets the ACMA (Australian Communications and Media Authority) requirements for network integrity, interoperability, performance characteristics as well as health and safety regulations. Here, especially the regulatory arrangements for electromagnetic compatibility are met. The products bear the RCM marking on the nameplate.



A0029561

<b>EAC conformity</b>	<p>The device meets the legal requirements of the applicable EAC Directives. These are listed in the corresponding EAC Declaration of Conformity along with the standards applied.</p> <p>Endress+Hauser confirms successful testing of the device by affixing to it the EAC mark.</p>
<b>Approval</b>	CSA C/US General Purpose
<b>Pressure Equipment Directive 2014/68/EU (PED)</b>	<p><b>Pressure equipment with permitted pressure <math>\leq 200</math> bar (2 900 psi)</b></p> <p>Pressure equipment (maximum allowable pressure (MWP) <math>PS \leq 200</math> bar (2 900 psi)) can be classified as pressure accessories in accordance with Pressure Equipment Directive 2014/68/EU. If the maximum allowable pressure is <math>\leq 200</math> bar (2 900 psi) and the pressurized volume of the pressure equipment is <math>\leq 0.1</math> l, the pressure equipment is subject to the Pressure Equipment Directive (see Pressure Equipment Directive 2014/68/EU, Article 4, point 3). The Pressure Equipment Directive only requires that the pressure equipment shall be designed and manufactured in accordance with the "sound engineering practice of a Member State".</p> <p><i>Reasons:</i></p> <ul style="list-style-type: none"> <li>▪ Pressure Equipment Directive (PED) 2014/68/EU Article 4, point 3</li> <li>▪ Pressure equipment directive 2014/68/EU, Commission's Working Group "Pressure", Guideline A-05 + A-06</li> </ul> <p><i>Note:</i></p> <p>A partial examination shall be performed for pressure instruments that are part of safety equipment for the protection of a pipe or vessel from exceeding allowable limits (safety accessory in accordance with Pressure Equipment Directive 2014/68/EU Article 2, point 4).</p>
<b>External standards and guidelines</b>	<p>The applicable European guidelines and standards can be found in the relevant EU Declarations of Conformity. The following standards were also applied:</p> <p><b>DIN EN 60770 (IEC 60770):</b></p> <p>Transmitters for use in industrial process control systems Part 1: Methods for performance evaluation</p> <p>Methods for evaluating the performance of transmitters for control and regulation in industrial process control systems.</p> <p><b>DIN 16086:</b></p> <p>Electrical pressure measuring instruments, pressure sensors, pressure transmitters, pressure measuring instruments, concepts, specifications in data sheets</p> <p>Procedure for writing specifications in data sheets for electrical pressure measuring instruments, pressure sensors and pressure transmitters.</p> <p><b>EN 61326-X:</b></p> <p>EMC product family standard for electrical equipment for measurement, control, regulation and laboratory procedures.</p> <p><b>EN 60529:</b></p> <p>Degrees of protection provided by enclosures (IP code)</p> <p><b>NAMUR - User association of automation technology in process industries.</b></p> <p>NE21 - Electromagnetic Compatibility (EMC) of Industrial Process and Laboratory Control Equipment.</p> <p>NE43 - Standardization of the Signal Level for the Failure Information of Digital Transmitters.</p>

NE44 - Standardization of Status Indicators on PCT Instruments with the Help of Light Emitting Diodes

NE53 - Software of Field Devices and Signal-processing Devices with Digital Electronics

**CRN approval**

Some device versions have CRN approval. A CRN-approved process connection with a CSA approval must be ordered for a CRN-approved device. The CRN-approved devices are assigned the registration number OF18141.5C.

Ordering information: Product Configurator, order code for "Process connection" (the CRN process connections are indicated appropriately in the "Mechanical construction" section.)

**Calibration unit**

Description	Option <sup>1)</sup>
Sensor range; %	A
Sensor range; mbar/bar	B
Sensor range; kPa/MPa	C
Sensor range; psi	F
Customer-specific; see additional spec.	J

1) Product Configurator, order code for "Calibration; unit"

**Calibration**

Description	Option <sup>1)</sup>
3-point calibration certificate <sup>2)</sup>	F3

- 1) Product Configurator, order code for "Calibration"
- 2) No final test report for PNP outputs.

**Inspection certificates**

Description	Option <sup>1)</sup>
3.1 Material documentation, wetted metal parts, EN10204-3.1 inspection certificate	YES

1) Product Configurator, order code for "Test, Certificate"



Documentation currently available on the Endress+Hauser website: [www.endress.com](http://www.endress.com) → Downloads or with the serial number of the device under Online Tools in the Device Viewer.

**Service**

- Cleaned of oil+grease (wetted)
- Checked, cleaned for oxygen application
- Min. alarm current set

*Product documentation on paper*

A printed (hard copy) version of test reports, declarations and inspection certificates can optionally be ordered via order code 570 "Service", option I7 "Product documentation on paper". The documents are then provided with the device upon delivery.

## Ordering information

Detailed ordering information is available from your nearest sales organization [www.addresses.endress.com](http://www.addresses.endress.com) or in the Product Configurator at [www.endress.com](http://www.endress.com):

1. Select the product using the filters and search field.
2. Open the product page.

### 3. Select Configuration.



#### Product Configurator - the tool for individual product configuration

- Up-to-the-minute configuration data
- Depending on the device: Direct input of measuring point-specific information such as measuring range or operating language
- Automatic verification of exclusion criteria
- Automatic creation of the order code and its breakdown in PDF or Excel output format
- Ability to order directly in the Endress+Hauser Online Shop

#### Scope of delivery

- Measuring device
- Optional accessories
- Brief Operating Instructions
- Certificates

## Accessories

#### M12 plug-in jacks

##### M12 plug (self-configurable connection to M12 plug)

- Degree of protection: IP67
- Material:
  - Union nut: Cu Sn/Ni
  - Body: PBT
  - Seal: NBR
- Option <sup>4)</sup>: R1
- Order number: 52006263

##### M12 plug, angled with 5 m (16 ft) cable

- Degree of protection: IP67
- Material:
  - Union nut: GD Zn/Ni
  - Body: PUR
  - Cable: PVC
- Cable colors:
  - 1 = BN = brown
  - 2 = WT = white
  - 3 = BU = blue
  - 4 = BK = black
- Option <sup>5)</sup>: RZ
- Order number: 52010285

##### M12 plug, angled (self-configurable connection to M12 plug)

- Degree of protection: IP67
- Material:
  - Union nut: GD Zn/Ni
  - Body: PBT
  - Seal: NBR
- Option <sup>6)</sup>: RM
- Order number: 71114212

4) Product Configurator: order code "620"

5) Product Configurator: order code "620"

6) Product Configurator: order code "620"

## Documentation

The following document types are available in the Downloads area of the Endress+Hauser website ([www.endress.com/downloads](http://www.endress.com/downloads)):



For an overview of the scope of the associated Technical Documentation, refer to the following:

- *W@M Device Viewer* ([www.endress.com/deviceviewer](http://www.endress.com/deviceviewer)): Enter the serial number from the nameplate
- *Endress+Hauser Operations App*: Enter the serial number from the nameplate or scan the matrix code on the nameplate

---

<b>Field of activities</b>	Pressure measurement, powerful instruments for process pressure, differential pressure, level and flow: FA00004P
----------------------------	---------------------------------------------------------------------------------------------------------------------

---

<b>Technical Information</b>	<ul style="list-style-type: none"><li>▪ TI00241F: EMC Test Procedures</li><li>▪ TI00426F: Weld-in adapters, process adapters and flanges (overview)</li></ul>
------------------------------	---------------------------------------------------------------------------------------------------------------------------------------------------------------



[www.addresses.endress.com](http://www.addresses.endress.com)

---