

TransPort® PT900

Portable Ultrasonic Flow Meter for Liquids User's Manual



TransPort® PT900

Portable Ultrasonic Flow Meter for Liquids

User's Manual

BH033C11 Rev. D
Sep 2022

panametrics.com

Copyright 2022 Baker Hughes company.

This material contains one or more registered trademarks of Baker Hughes Company and its subsidiaries in one or more countries. All third-party product and company names are trademarks of their respective holders.

[no content intended for this page]

Typographical Conventions	vii
Safety Issues	viii
Auxiliary Equipment	ix
Product Registration	x
Services	x
Terms and Conditions	x
Regulatory Compliance	xi
Chapter 1. Introduction	
1.1 Product Registration	1
1.2 System Description	1
Chapter 2. Installation	
2.1 Introduction	3
2.2 Unpacking the PT900	4
2.3 Installing a Battery Pack in the Transmitter	6
2.4 Mounting the PT900 Transmitter	7
2.5 Installing the Clamp-On Fixture and Transducers	7
2.5.1 A Sample Installation	8
2.5.2 Transducer Spacing Calculation	9
2.5.3 Mounting the PT9 Clamp-On Fixture	9
2.5.4 Checking the Transducer Holders	16
2.5.5 Installing the Transducers.	17
2.5.6 Even and Odd-Transpose Installations	21
2.6 Making the Electrical Connections	33
2.6.1 Connecting the Line Power	33
2.6.2 Connecting the Transducers	35
2.6.3 Connecting the Digital Output	36
2.6.4 Connecting the Analog Inputs and Output	37
2.6.5 Connecting the Energy Cables	37
2.6.6 Using the USB Port	38
2.6.7 Using the Bluetooth Wireless Interface	38
2.7 Caring for the PT900 Batteries	38
2.7.1 Charging and Storing the Batteries	39
2.7.2 Replacing the Batteries	40
2.7.3 Disposing of the Batteries	41
2.8 Powering On and Off	41
2.9 PT900 LED Indicators	42
2.9.1 Power LED	43
2.9.2 Bluetooth LED	43
2.9.3 Status LED	43
2.9.4 Battery LED	43

Chapter 3. Initial Setup

3.1 Introduction..... 45

3.2 Charging the PT900 Transmitter and Tablet..... 45

3.3 Installing or Updating the PT900 APP..... 45

 3.3.1 Checking the APP Version..... 45

 3.3.2 Installing or Updating the PT900 Android and iOS APP..... 46

 3.3.3 Installing the Tablet APP from the SD Card (Applicable only to Android APP)47

3.4 Pairing the Tablet and the Transmitter..... 49

 3.4.1 Removing paired devices from PT900 APP..... 58

 3.4.2 Removing paired devices from iPhone/Tablet..... 59

3.5 Using the APP Main Menu and the Slide Menu..... 61

 3.5.1 The Main Menu..... 61

 3.5.2 The Slide Menu (Applicable only to Android)..... 62

Chapter 4. Programming

4.1 Configuring the Units of Measurement..... 63

4.2 Configuring a Channel..... 65

4.3 Programming the PIPE Menu..... 67

 4.3.1 Pipe Materials..... 68

 4.3.2 Pipe Dimensions..... 68

 4.3.3 Pipe Lining..... 69

4.4 Programming the FLUID Menu..... 70

4.5 Programming the TRANSDUCERS Menu..... 73

 4.5.1 Programming the Transducer Parameters..... 74

 4.5.2 Setting the Reynolds Correction Factor..... 76

 4.5.3 Programming the Meter Factor..... 76

4.6 Programming the PLACEMENT Menu..... 78

 4.6.1 Viewing the Traverse Configuration..... 78

 4.6.2 Viewing the Transducer Spacing..... 79

4.7 Configuring the Program Options..... 83

 4.7.1 Programming the ENERGY Tab..... 85

 4.7.2 Programming the INPUTS Tab..... 87

 4.7.3 Programming the OUTPUTS Tab..... 88

 4.7.4 Programming the USER FUNCTIONS Tab..... 93

Chapter 5. Measurements

5.1 Introduction..... 97

5.2 Setting Up the Measurements for Display..... 98

5.3 Viewing Measurements..... 100

 5.3.1 Displaying Multiple Measurements..... 101

 5.3.2 Displaying a Single Measurement..... 102

 5.3.3 Displaying the Totalizer Screen..... 105

 5.3.4 Displaying the Diagnostics Parameters..... 106

Chapter 6. Logging Data	
6.1	Introduction.....107
6.2	Adding a Log.....108
6.3	Deleting, Stopping or Editing a Log.....110
6.3.1	Deleting a Log.....111
6.3.2	Editing a Log.....112
6.3.3	Viewing a Log.....113
Chapter 7. Configuring the Transmitter	
7.1	Introduction.....115
7.2	Updating the PT900 Transmitter Software.....118
7.3	Programming the Transmitter SERVICE Menu.....121
7.3.1	Programming the CALIBRATION Menu.....121
7.3.2	Programming the METER SETUP Menu.....124
7.3.3	Programming the TESTING Menu.....127
7.3.4	Programming the ERROR LIMITS Menu.....130
Chapter 8. Error Codes and Troubleshooting	
8.1	Error Codes.....133
8.1.1	Error Header.....133
8.1.2	Flow Errors.....133
8.2	Diagnostics.....135
8.2.1	Introduction.....135
8.2.2	Fluid and Pipe Problems.....135
8.3	Diagnostic Parameters.....138
8.4	Getting Help.....139
8.4.1	The About Screen.....140
8.4.2	The Diagnostics Screen.....141
8.4.3	The Service Screen.....142
8.4.4	The Spare Parts Screen.....143
8.5	Help Topics List.....144
8.6	The Quick-Start Guide.....146
Chapter 9. Communication	
9.1	Modbus Communication.....147
9.2	Modbus Register Map.....147
9.3	Bluetooth Communication.....156
Appendix A. Specifications	
A.1	Operation and Performance.....157
A.2	PT900 Flow Transmitter.....158
A.3	User Interface.....159
A.4	Software Application (PT900 APP).....159
A.5	Clamp-On Transducers.....160
A.6	Accessories.....160
A.7	Options.....161
A.8	Customer Cable Requirements for AIO/DIO Connections.....161

Appendix B. Data Records

B.1 Service Record 163

B.2 Initial Settings..... 164

B.3 Initial Diagnostic Parameters..... 165

Typographical Conventions

Note: *“Note” paragraphs provide additional information about the topic which is helpful but is not essential to proper completion of the task.*

Important : *“Important” paragraphs provide emphasis to instructions that are essential to proper setup of the equipment. Failure to follow these instructions carefully may cause unreliable performance.*



CAUTION! *“Caution” paragraphs indicate a potentially hazardous situation which can result in minor or moderate injury to personnel or damage to the equipment.*



WARNING! *“Warning” paragraphs indicate a potentially hazardous situation which can result in serious personal injury or death.*

Paragraphes d'informations

Remarque : *Ces paragraphes fournissent des informations à même de faciliter la compréhension de la situation, mais n'est pas indispensable à la bonne utilisation des instructions.*

Important: *Ces paragraphes fournissent des informations qui mettent l'accent sur les instructions qui sont essentielles à une configuration correcte de l'équipement. Le non-respect de ces instructions peut entraîner une dégradation des performances.*



MISE EN GARDE ! Ce symbole indique un risque potentiel mineur de blessure aux personnes et / ou de sérieux dommages à l'équipement, à moins que ces instructions soient rigoureusement suivies.



AVERTISSEMENT ! Ce symbole indique un risque potentiel grave de blessures aux personnes, à moins que ces instructions soient rigoureusement suivies.

Safety Issues



WARNING! It is the responsibility of the user to make sure all local, county, state and national codes, regulations, rules and laws related to safety and safe operating conditions are met for each installation.



WARNING! If the clamp-on fixture and transducers are installed on a pipeline above a work area or walkway, safe work site practices for protection from falling objects must be followed.



WARNING! It is the responsibility of the user to make sure the PWR, Hart, Modbus and IO cables meet the cable specifications listed in *Appendix A*.

Questions de sécurité



AVERTISSEMENT! Il est de la responsabilité de l'utilisateur de s'assurer que tous les règlements, codes et lois locaux, nationaux et européens relatifs à la sécurité et aux conditions d'exploitation en toute sécurité soient respectés pour chaque installation. La sécurité de tout système intégrant l'équipement est de la responsabilité de celui qui l'assemble.



AVERTISSEMENT! If the clamp-on fixture and transducers are installed on a pipeline above a work area or walkway, safe work site practices for protection from falling objects must be followed.



AVERTISSEMENT! Il est de la responsabilité de l'utilisateur de s'assurer que les câbles d'alimentation, Hart, Modbus et Entrées / Sorties répondent à la spécification décrite à l'annexe A.

Auxiliary Equipment

Local Safety Standards

The user must make sure that he operates all auxiliary equipment in accordance with local codes, standards, regulations, or laws applicable to safety.

Working Area



WARNING! Auxiliary equipment may have both manual and automatic modes of operation. As equipment can move suddenly and without warning, do not enter the work cell of this equipment during automatic operation, and do not enter the work envelope of this equipment during manual operation. If you do, serious injury can result.



WARNING! Make sure that power to the auxiliary equipment is turned OFF and locked out before you perform maintenance procedures on the equipment.

Matériel auxiliaire

Standards de sécurité locaux

L'utilisateur doit s'assurer que les équipements auxiliaires utilisés sont en tout point conforme aux codes, standards et réglementations relatifs à la sécurité.

Zone de travail



AVERTISSEMENT! Les équipements auxiliaires peuvent avoir à la fois des modes de fonctionnement manuel et automatique. Comme l'équipement peut bouger brusquement et sans signe préalable, ne pas entrer dans la zone de travail de ce dernier pendant le fonctionnement automatique, et ne pas s'en approcher de trop près pendant le fonctionnement manuel. Si vous le faites, cela peut entraîner de graves blessures.



AVERTISSEMENT! Assurez-vous que l'alimentation de l'équipement auxiliaire est éteinte et verrouillée avant d'effectuer toute opération de maintenance ou d'entretien de l'équipement.

Qualification of Personnel

Make sure that all personnel have manufacturer-approved training applicable to the auxiliary equipment.

Personal Safety Equipment

Make sure that operators and maintenance personnel have all the safety equipment applicable to the auxiliary equipment. Examples include safety glasses, protective headgear, safety shoes, etc.

Unauthorized Operation

Make sure that unauthorized personnel cannot gain access to the operation of the equipment.

Services

Panametrics provides customers with an experienced staff of customer support personnel ready to respond to technical inquiries, as well as other remote and on-site support needs. To complement our broad portfolio of industry-leading solutions, we offer several types of flexible and scalable support services including: Training, Product Repairs, Service Agreements and more. Please visit <https://www.bakerhughes.com/panametrics/panametrics-services> for more details.

Regulatory Compliance

Waste Electrical and Electronic Equipment (WEEE) Directive

Panametrics is an active participant in Europe's *Waste Electrical and Electronic Equipment* (WEEE) take-back initiative (Directive 2012/19/EU).

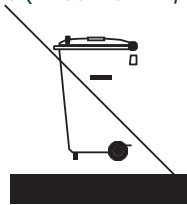

The equipment that you bought has required the extraction and use of natural resources for its production. It may contain hazardous substances that could impact health and the environment.

In order to avoid the dissemination of those substances in our environment and to diminish the pressure on the natural resources, we encourage you to use the appropriate take-back systems. Those systems will reuse or recycle most of the materials of your end life equipment in a sound way. The crossed-out wheeled bin symbol invites you to use those systems.

If you need more information on the collection, reuse and recycling systems, please contact your local or regional waste administration.

RoHS

The *TransPort*[®] PT900 fully complies with RoHS regulations (Directive 2011/65/EU).

FCC Rules/Industry Canada License



CAUTION! This device complies with Part 15 of the FCC Rules / Industry Canada licence-exempt RSS standard(s). Operation is subject to the following two conditions: (1) this device may not cause harmful interference, and (2) this device must accept any interference received, including interference that may cause undesired operation.



MISE EN GARDE ! Le présent appareil est conforme aux CNR d'Industrie Canada applicables aux appareils radio exempts de licence. L'exploitation est autorisée aux deux conditions suivantes : (1) l'appareil ne doit pas produire de brouillage, et (2) l'utilisateur de l'appareil doit accepter tout brouillage radioélectrique subi, même si le brouillage est susceptible d'en compromettre le fonctionnement.

Changes or modifications not expressly approved by the party responsible for compliance could void the user's authority to operate the equipment.

This equipment has been tested and found to comply with the limits for a Class B digital device, pursuant to part 15 of the FCC Rules. These limits are designed to provide reasonable protection against harmful interference in a residential installation. This equipment generates uses and can radiate radio frequency energy and, if not installed and used in accordance with the instructions, may cause harmful interference to radio communications. However, there is no guarantee that interference will not occur in a particular installation. If this equipment does cause harmful interference to radio or television reception, which can be determined by turning the equipment off and on, the user is encouraged to try to correct the interference by one or more of the following measures:

- Reorient or relocate the receiving antenna.
- Increase the separation between the equipment and receiver.
- Connect the equipment into an outlet on a circuit different from that to which the receiver is connected.
- Consult the dealer or an experienced radio/TV technician for help.

FCC Rules/Industry Canada License (cont.)

Under Industry Canada regulations, this radio transmitter may only operate using an antenna of a type and maximum (or lesser) gain approved for the transmitter by Industry Canada. To reduce potential radio interference to other users, the antenna type and its gain should be so chosen that the equivalent isotropically radiated power (e.i.r.p.) is not more than that necessary for successful communication.

Conformément à la réglementation d'Industrie Canada, le présent émetteur radio peut fonctionner avec une antenne d'un type et d'un gain maximal (ou inférieur) approuvé pour l'émetteur par Industrie Canada. Dans le but de réduire les risques de brouillage radioélectrique à l'intention des autres utilisateurs, il faut choisir le type d'antenne et son gain de sorte que la puissance isotrope rayonnée équivalente (p.i.r.e.) ne dépasse pas l'intensité nécessaire à l'établissement d'une communication satisfaisante.

This device complies with Industry Canada's licence-exempt RSSs. Operation is subject to the following two conditions:

1. This device may not cause interference; and
2. This device must accept any interference, including interference that may cause undesired operation of the device.

MPE Reminding

To satisfy FCC/IC RF exposure requirements, a separation distance of 20 cm or more should be maintained between the antenna of this device and persons during device operation. To ensure compliance, operations at closer than this distance is not recommended.

Les antennes installées doivent être situées de façon à ce que la population ne puisse y être exposée à une distance de moins de 20 cm. Installer les antennes de façon à ce que le personnel ne puisse approcher à 20 cm ou moins de la position centrale de l'antenne. La FCC des États-Unis stipule que cet appareil doit être en tout temps éloigné d'au moins 20 cm des personnes pendant son fonctionnement.

Taiwan Warning Letter

低功率電波輻射性電機管理辦法

第十二條 經型式認證合格之低功率射頻電機，非經許可，公司、商號或使用者均不得擅自變更頻率、加大功率或變更原設計之特性及功能。

第十四條 低功率射頻電機之使用不得影響飛航安全及干擾合法通信；經發現有干擾現象時，應立即停用，並改善至無干擾時方得繼續使用。

Korean KCC Warning

1. EMC (B Type) Warning

기기종별	사용자안내문
B 급 기기 (가정용 정보통신기기)	이 기기는 가정용 (B 급) 전자파적합기기로서 주로 가정에서 사용하는 것을 목적으로 하며, 모든 지역에서 사용할 수 있습니다. 이 기기는 가정용 (B 급) 전자파적합기기로서 주로 가정에서 사용하는 것을 목적으로 하며, 모든 지역에서 사용할 수 있습니다.

2. RF Warning

당해 무선설비는 전파혼신 가능성이 있으므로 인명안전과 관련된 서비스는 할 수 없음

[no content intended for this page]

Chapter 1. Introduction

1.1 Product Registration

Thank you for purchasing a TransPort[®] PT900 from Panametrics. Please register your product at www.bakerhughes.com/productregistration for product support such as the latest software/firmware upgrades, product information and special promotions.

1.2 System Description

The PT900 is a portable flow transmitter for the measurement of liquid products. It utilizes a new electronics platform and a simplified industrial design to make it extremely easy to install and use. The system includes: a transmitter, a pair of transducers, a new clamp-on fixture and a transducer cable (see *Figure 1* below).

Optional accessories for the PT900 include: a tablet with the Android[®] or iOS operating system (see *Figure 1* below), a thickness gauge, clamp-on temperature transmitters and a clamp-on mounting fixture for pipes up to 48" in diameter. The PT900 communicates with its remote *display tablet* via Bluetooth[®].



Figure 1: A PT900 Mounted on a Pipe and a Tablet (sold separately)

[no content intended for this page]

Chapter 2. Installation

2.1 Introduction

To ensure safe and reliable operation of the PT900, the system must be installed in accordance with established Panametrics guidelines. Those guidelines are explained in detail in this chapter and include the following topics:

- Unpacking the PT900 (see page 4)
- Mounting the PT900 Transmitter (see page 7)
- Installing the Clamp-On Fixture and Transducers (see page 7)
- Making the Electrical Connections (see page 33)



WARNING! The PT900 flow transmitter can measure the flow rate of many fluids, some of which are potentially hazardous. The importance of proper safety practices cannot be overemphasized.



WARNING! Be sure to follow all applicable local safety codes and regulations for installing electrical equipment and working with hazardous fluids or flow conditions. Consult company safety personnel or local safety authorities to verify the safety of any procedure or practice.



ATTENTION EUROPEAN CUSTOMERS! To meet CE Mark and UL Mark requirements, all cables must meet the specifications in *“Customer Cable Requirements for AIO/DIO Connections”* on page 161.

2.2 Unpacking the PT900

Before removing the PT900 from its carrying case (see the optional hard shell carrying case in *Figure 2 on page 5*), inspect the contents of the case carefully. Before discarding any of the packing materials, account for all components and documentation listed on the packing slip. If anything is missing or damaged, contact *Panametrics Customer Care* immediately for assistance.

Because the PT900 may be ordered in many different configurations, the following packing list is shown only as a typical example:

- | | |
|----------------------|-----------------------------------|
| 1. Transducers (2) | 7. Case |
| 2. Clamping Fixture | 8. PT900 Power Supply |
| 3. Transducer Cables | 9. OD Tape |
| 4. Transmitter | 10. Couplant |
| 5. Tablet Power Cord | 11. PT900 Mounting Strap w/Magnet |
| 6. SD Card | |

In addition to the standard components, the following optional components are available for use with the PT900:

12. Tablet with protective case
13. Energy kit with an RTD module and an RTD cable for connection to the PT900 transmitter
14. AIO cable with cabling box
 - DIO cable with cabling box
 - Battery charger
 - Transducer extension cable up to 100 ft long
 - 48" chain for the clamp-on fixture

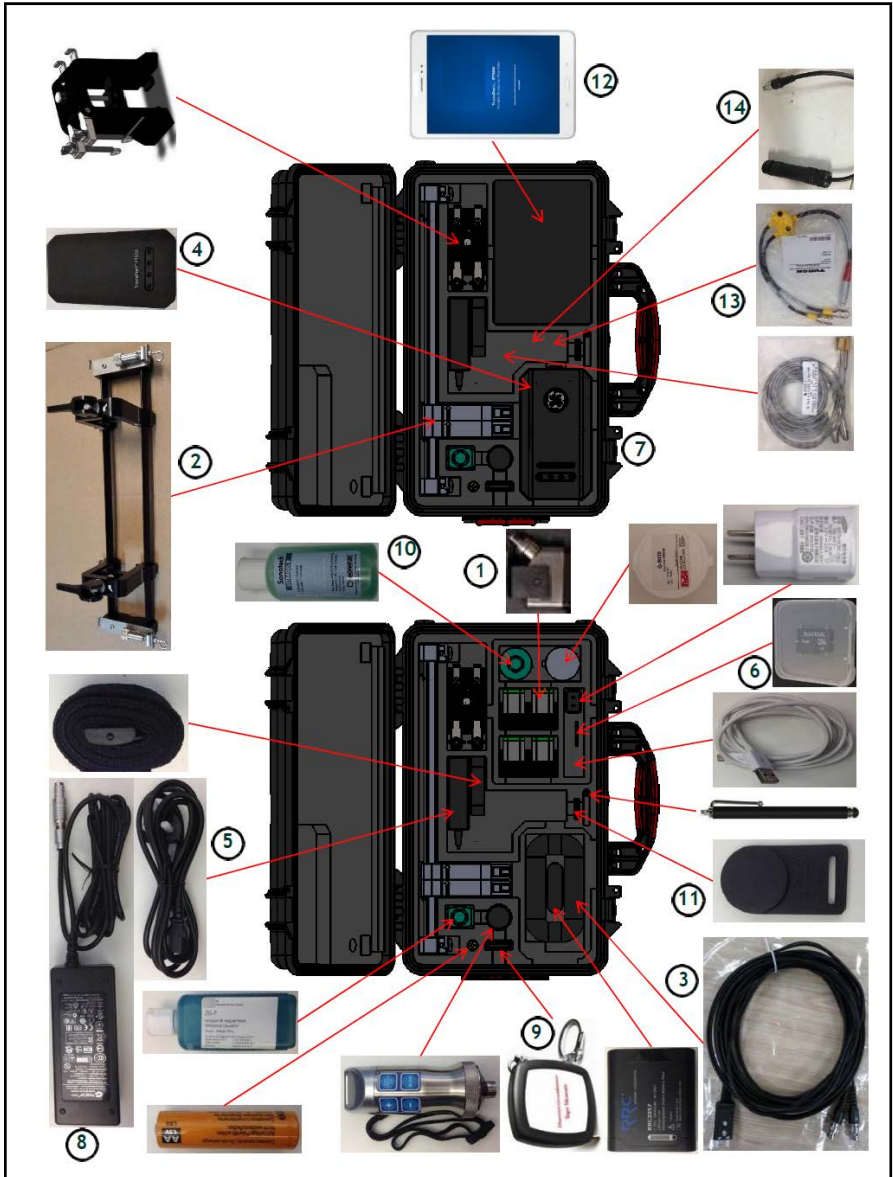

Figure 2: PT900 in Hard Carrier Case

2.3 Installing a Battery Pack in the Transmitter

To install a new battery pack in the transmitter (see *Figure 3* below):

1. Using a slotted screwdriver, rotate the two quick-screws on the battery cover 90° to open the transmitter.
2. Remove the existing battery pack.
3. Install the new battery pack in the battery compartment and replace the battery cover. Secure the cover by tightening the two quick-screws.

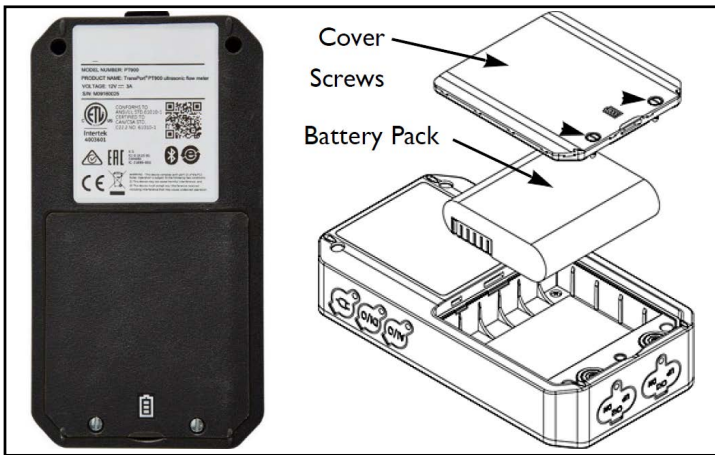

Figure 3: Installing the Battery Pack in the Transmitter

2.4 Mounting the PT900 Transmitter

The PT900 portable transmitter is housed in a durable rubberized enclosure suitable for indoor or outdoor use. It can be placed in the hard carrier case or mounted on the pipe with the either the soft strap or the magnetic clamp (see *Figure 4* below).

Note: *The pipe temperature must be between -20°C and about $+40^{\circ}\text{C}$ to safely use the soft strap or magnetic clamp for mounting the transmitter.*

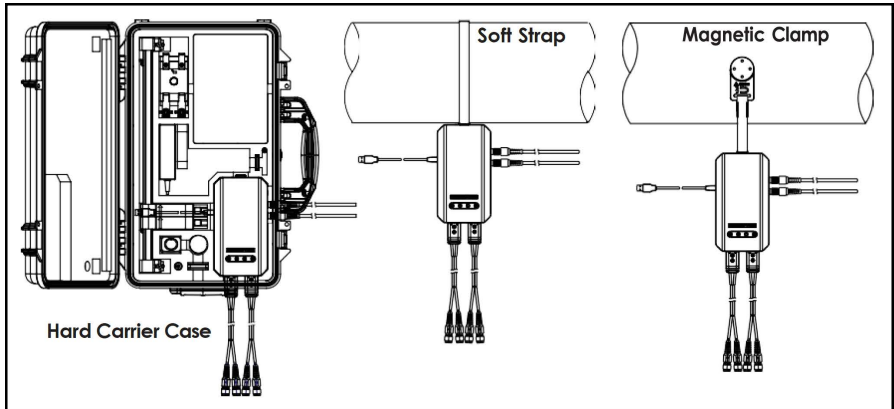

Figure 4: PT900 Transmitter Mounting Options

2.5 Installing the Clamp-On Fixture and Transducers

This section describes in detail how to mount the standard PT9 clamp-on transducer fixture on the pipe.

Note: *Consult Panametrics for instructions on installing the optional CF-LP clamping fixture (shown in *Figure 5* below).*

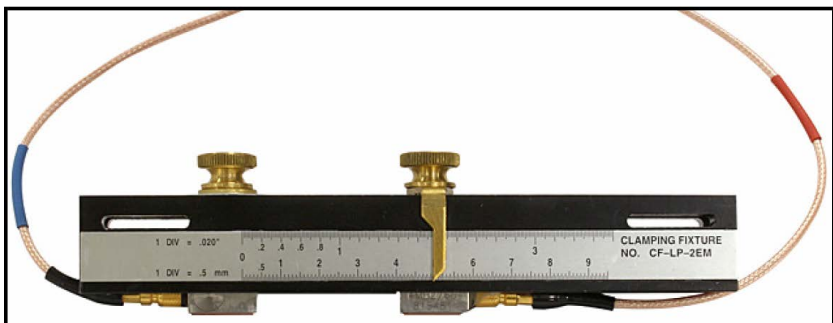

Figure 5: CF-LP Clamping Fixture

2.5.1 A Sample Installation

For reference, a typical completed PT900 installation is shown in Figure 6 below.

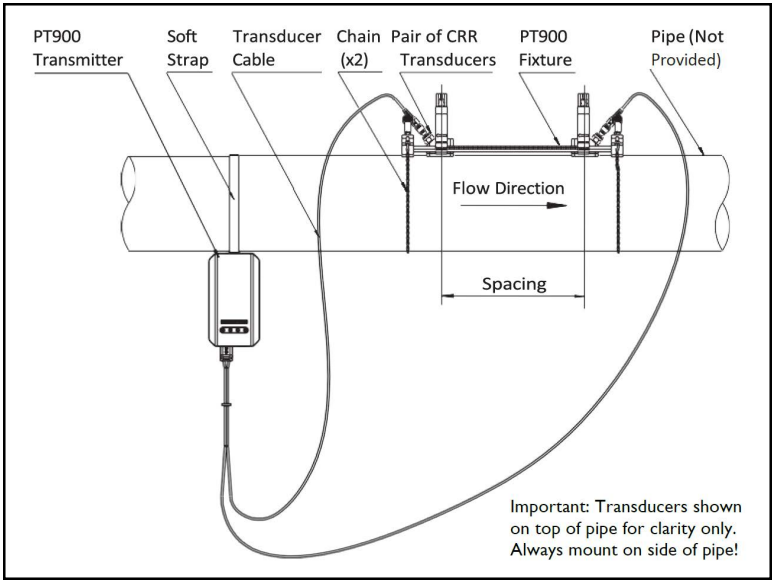

Figure 6: Typical PT900 Installation

2.5.2 Transducer Spacing Calculation



ATTENTION! The required transducer spacing is calculated by the APP after you program the PIPE, FLUID, TRANSDUCER and PLACEMENT menus. Before proceeding with this installation, you must complete the programming starting in Chapter 4.

Programming on page 63 up to “Viewing the Transducer Spacing” on page 79. Use that calculated transducer spacing in the following sections.

2.5.3 Mounting the PT9 Clamp-On Fixture

To mount the PT9 clamp-on fixture (see Figure 7 below) on the pipe, complete the following steps:

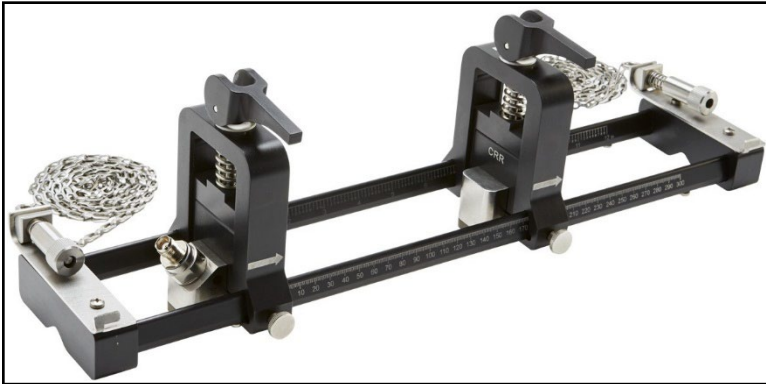

Figure 7: PT9 Clamp-On Fixture with CRR Transducers

1. Before mounting the clamp-on fixture, refer to Figure 8 on page 10 and proceed as follows:
 - Ensure that the chain mechanism screws (A) that are attached to the end piece flats are fully loosened.
 - Ensure that the last link on the chain is secured within the chain mechanism screw slot (B) on both sides of the end piece.
 - Ensure that the thumb screw (C) is tightened on the movable clamp so that no motion is allowed during the mounting process.

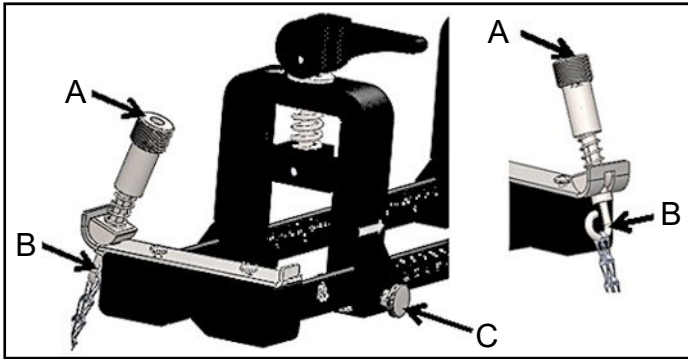

Figure 8: Bracket Preliminary Setup

2. Select a clamp-on fixture mounting location on the pipeline which meets the following requirements (see Figure 9 below):
 - A straight pipe run of at least 10 nominal pipe diameters (with no fittings or bends) before the upstream transducer
 - A straight pipe run of at least 5 nominal pipe diameters (with no fittings or bends) after the downstream transducer
 - A clearance of at least 6" (150 mm) from the outer edge of each end piece to the nearest joint, welding or flange in the pipeline

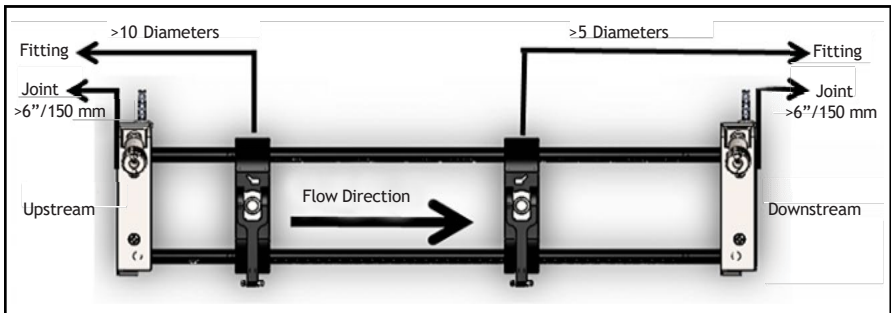

Figure 9: Selecting the Pipe Location

- Adjust the clamp-on fixture position so that the outer edge of the closest end piece is located at the chosen distance from the nearest inlet, outlet, joint or fitting in the pipeline (see Figure 10 below).

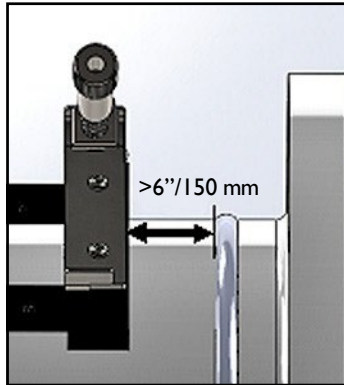

Figure 10: Adjusting the Fixture Position

- Place the clamp-on fixture on top of the pipe so that minimal effort is required to maintain its position during installation (see Figure 11 below).

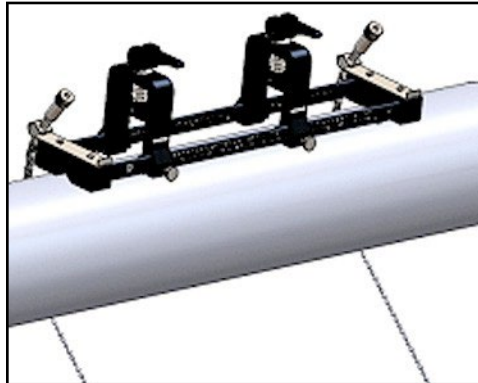

Figure 11: Fixture Placed on Top of Pipe

5. Verify that the pipe rests in the small cutout slot on the bottom of the end pieces (see Figure 12 below). Also, be sure that the scale markings on the rail rod of the clamp-on fixture can be easily read after the installation has been completed.



Figure 12: Cutout Slot

6. To install a chain around the pipe, refer to Figure 13 on page 13 and complete the following steps:
 - a. Identify the chain screw mechanism, the end flat and the chain slot on the clamping fixture end piece closest to the reference pipe fitting.
 - b. Unscrew the chain screw mechanism, then wrap the metal chain all the way around the pipe.
 - c. Push down on the top of the chain screw mechanism and hold it down. Then, pull the chain so that it is snug around the pipe and slide the chain into the small slot located at the opposite side of the end piece from the chain screw mechanism.
 - d. Release the chain screw mechanism and tighten it just enough to remove any slack in the chain.

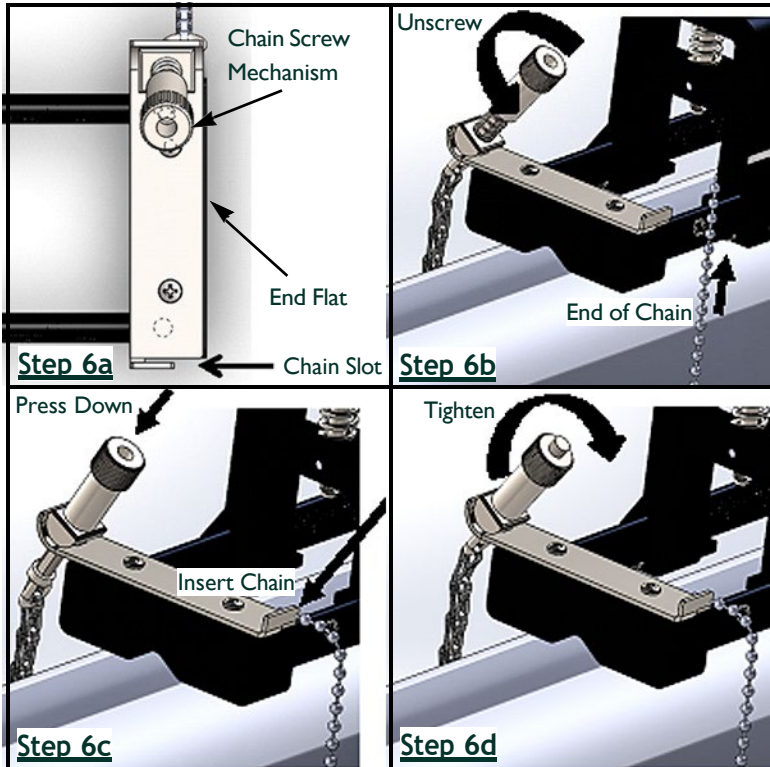

Figure 13: Installing a Chain

7. Repeat the previous steps to install the chain at the opposite end of the clamp-on fixture (see Figure 14 below). The clamp-on fixture should be firmly mounted to the pipe, but it should still be loose enough to allow final alignment.

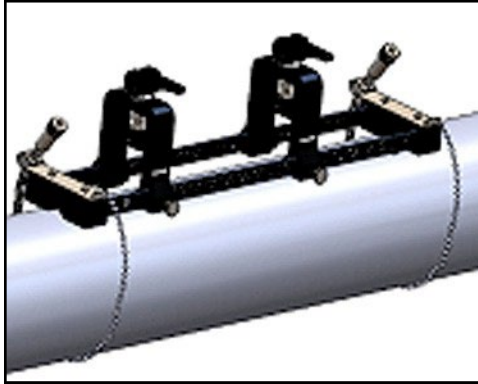

Figure 14: Fixture With Chains Installed

8. Rotate the fixture to the 3 o'clock or 9 o'clock position on the pipe (see Figure 15 below). Installation on the top or bottom of the pipe is not recommended. Make sure the pipe still rests in the cutout slot on the bottom of both end pieces, to ensure that the fixture is parallel to the pipe centerline.



Figure 15: Fixture Rotated to Horizontal Position

9. After final alignment is complete, fully tighten both chains by turning the nut on top of both chain screw mechanisms (see Figure 16 below) until the chain is tight enough to resist any fixture movement.

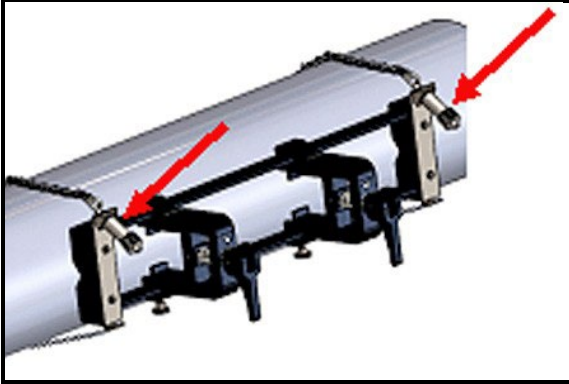

Figure 16: Secure the Fixture to the Pipe

Note: As the last two steps affect each other, repeat them until the fixture is both properly aligned and securely fastened to the pipe.

2.5.4 Checking the Transducer Holders

Before installing the transducers into the clamp-on fixture, a transducer holder must be attached to each transducer. A transducer holder is installed on each transducer by Panametrics prior to shipment. Verify that your transducers have their holders already installed and that they are secure. If so, you may skip this section.

A complete transducer assembly includes the following components:

- **Clamp Holder:** Permanently attached to the fixture clamp
- **Transducer Holder:** Semi-permanently attached to the transducer
- **Transducer:** Prior to mounting, the transducer is installed into the transducer holder and secured with set screws. During mounting, the transducer holder slides into the clamp holder and attaches with a plunger

If for some reason a transducer's holder was not installed or has been removed, refer to Figure 17 below and reinstall the holder as follows:

1. Slide the holder onto the top of the transducer so that the circle slots near the top of the transducer sides are closely aligned with the filled holes on the side of the transducer holder.
2. Screw the hex socket set screws from the transducer holder into the holes of the transducer. These screws will lock the holder into place.

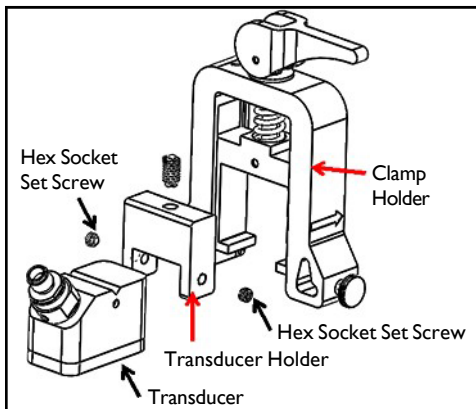

Figure 17: Transducer Assembly

2.5.5 Installing the Transducers

To install the transducers into the mounting bracket, complete the following steps:

1. If necessary, loosen the thumb screw on the movable transducer clamp to permit axial positioning.
2. Note that the fixed transducer clamp is set at the zero mark on the scale. Position the movable transducer clamp so that it aligns with the mark on the bracket's graduated scale that matches the calculated transducer spacing. Measurement markings should be read on the side of the transducer clamp indicated by the arrows. Typically, set the holder on the left to the zero position and the other holder to the desired spacing.

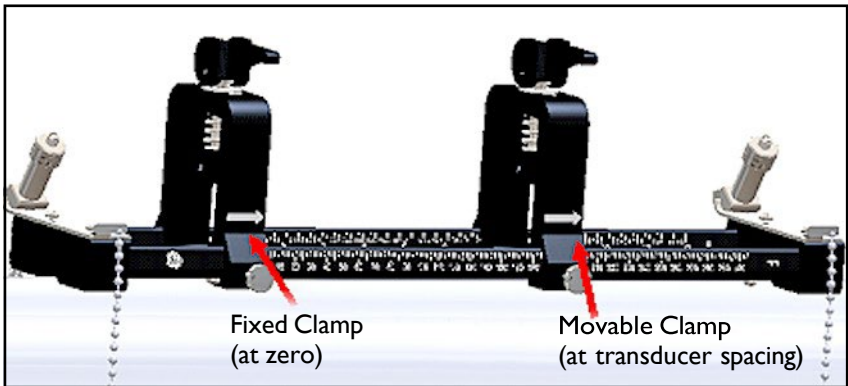

Figure 18: Secure the Fixture to the Pipe

Note: The required spacing between the transducers varies based on many factors. The tablet APP automatically calculates your transducer spacing. (see “Viewing the Transducer Spacing” on page 79).

3. Tighten the thumb screw to lock the movable transducer clamp into place, being cautious not to disturb the established axial positioning.

4. Move both cams to the loaded position, so that the clamp holders rest in their furthest radial position from the pipe (see Figure 19 below).

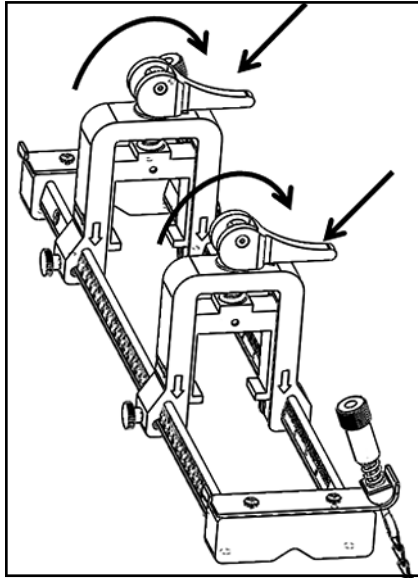

Figure 19: Loaded Cams

5. Apply the supplied couplant to both transducer faces (see Figure 20 below). The couplant displaces any air gaps between the transducer and the pipe to ensure a uniform acoustic signal path. For pipes up to 14" OD, do not apply couplant in the red areas shown; for pipes >14" OD, cover the entire surface with couplant.

Note: Using a water-based lubricant as a couplant is not recommended for heated or long-term installations.

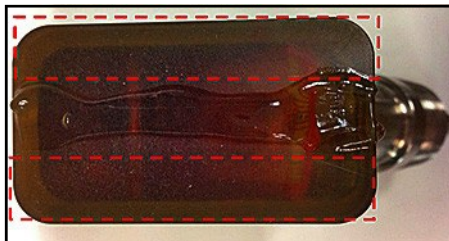

Figure 20: Transducer Face with Couplant

- Slide a transducer, which is already locked into its transducer holder, into one of the clamp-on fixture's clamp holders until the plunger from the top of the transducer holder snaps into its position on the bottom of the clamp holder (see Figure 21 below).

Important: The cable connectors on the mounted transducers must point away from each other and toward opposite ends of the clamp-on fixture. To assist in this requirement, the arrows on the end pieces help to indicate the cable connector direction.

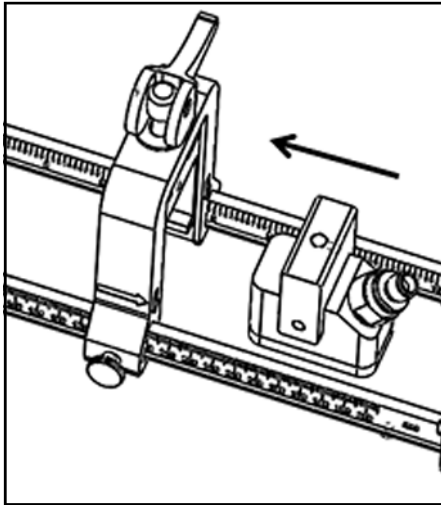

Figure 21: Inserting the Transducer

7. Release the cams on both transducer clamps so that the transducers are pushed towards the pipe to ensure that the couplant completely fills the gaps between the transducer faces and the pipe surface (see Figure 22 below).



CAUTION! When releasing the cams, the cam springs may cause the cam to make hard contact with the clamp face. Any objects or body parts between the contact faces could suffer damage or minor injury.

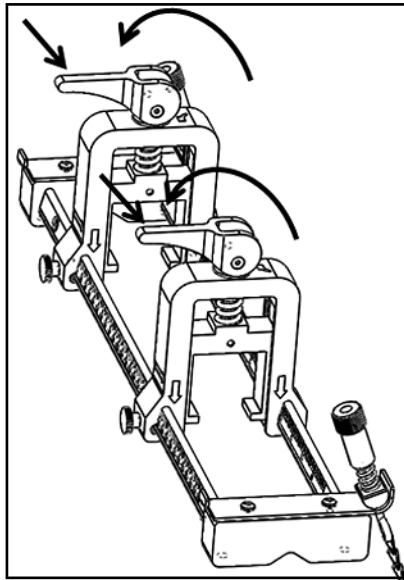

Figure 22: Released Cams

Important: You must determine the required transducer spacing before proceeding (see “Viewing the Transducer Spacing” on page 79).

2.5.5 Even and Odd-Traversal Installations

The transducers for a PT900 system may be installed in either of the following configurations:

- Even-Traversal - The signal from one of the transducers traverses the fluid flow an even number of times before being received by the other transducer (two traverses is recommended for most applications).
- Odd-Traversal - The signal from one of the transducers traverses the fluid flow once or an odd number of times before being received by the other transducer.

2.5.6 a Even-Traversal Installations (Spacing <305 mm/12 in.)

The standard PT900 clamp-on fixture is designed for an even-traversal installation, as illustrated in Figure 23 below. After mounting the clamp-on fixture on the pipe, refer to “Viewing the Transducer Spacing” on page 79 to adjust the spacing of the transducer clamps to the required axial distance.

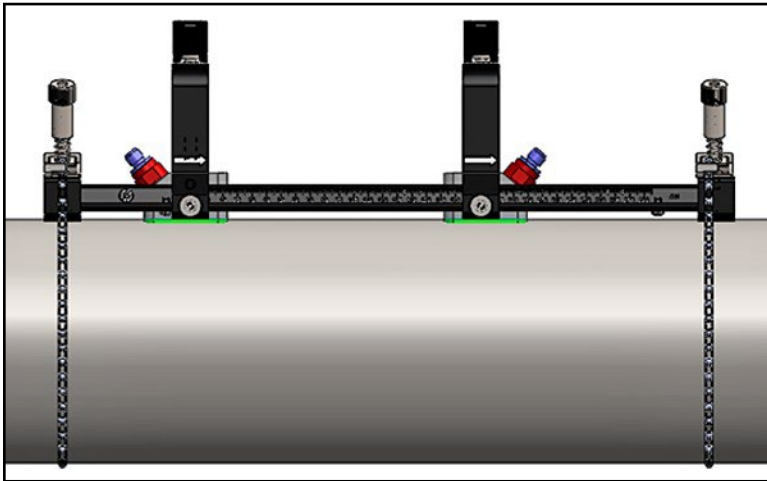

Figure 23: An Even-Traversal Installation (Top View)

Important: The installation above assumes a transducer spacing of <305 mm/12 in. For even-traversal installations with transducer spacings >305 mm/12 in., see “Even-Traversal Installations (Spacing >305 mm/12 in.)” on page 28 for instructions.

2.5.5 b Odd-Traversal Installations

For an odd-traverse installation, the separate yoke included with the clamp-on fixture is required (see Figure 24 below).

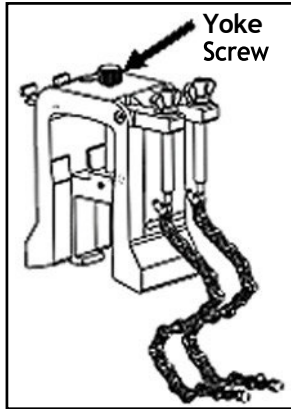

Figure 24: Yoke for Odd-Traversal Installations

Important: The clamping fixture must be installed before the yoke (see “Mounting the PT9 Clamp-On Fixture” on page 9). You must determine the required transducer spacing before proceeding (see “Viewing the Transducer Spacing” on page 79).

To install the yoke, complete the following steps:

1. Loosen the yoke screw at least 25 mm/1 in. (all the way for pipes <50 mm/2 in.) and loosen the J-Hooks all the way (see Figure 25 below).

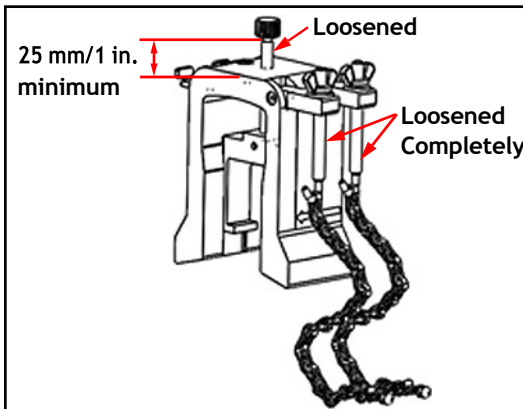

Figure 25: Loosened Yoke Screw and J-Hooks

2.5.6b Odd-Traversal Installations (cont.)

2. Place the yoke on the top of the pipe (see Figure 26 below). If the required transducer spacing is < 305 mm/12 in., the yoke chain must be placed within the clamping fixture as shown.

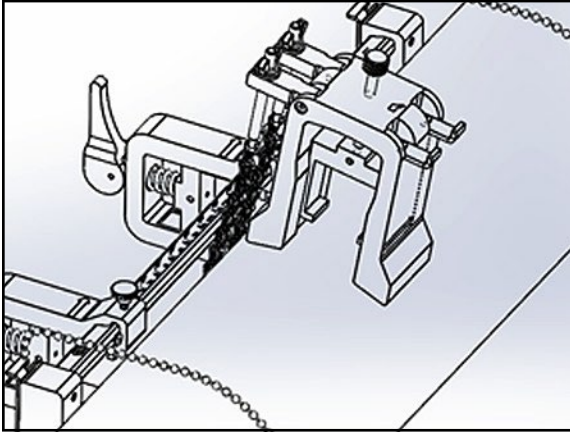

Figure 26: Yoke Placement On Top of Pipe

3. Wrap the yoke chains around the pipe and secure them to the yoke bracket, as shown in Figure 27 below.

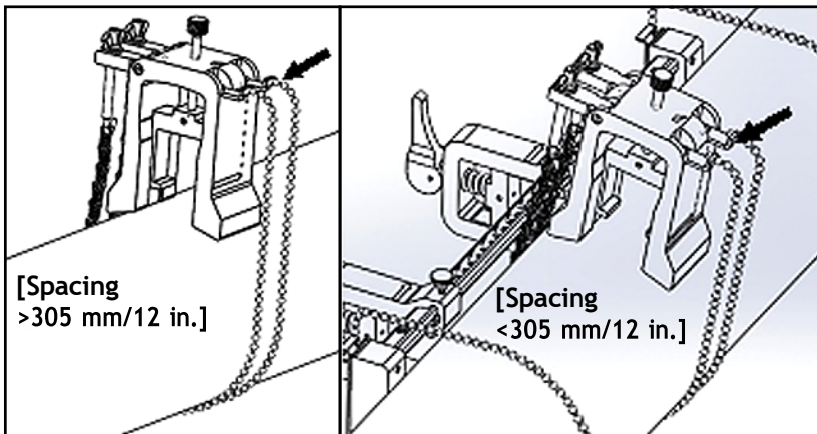

Figure 27: Yoke Chains Secured

2.5.6b Odd-Traversal Installations (cont.)

4. Rotate the yoke until it is located in a horizontal position on the opposite side of the pipe from the previously installed clamping fixture, as shown in Figure 28 below.

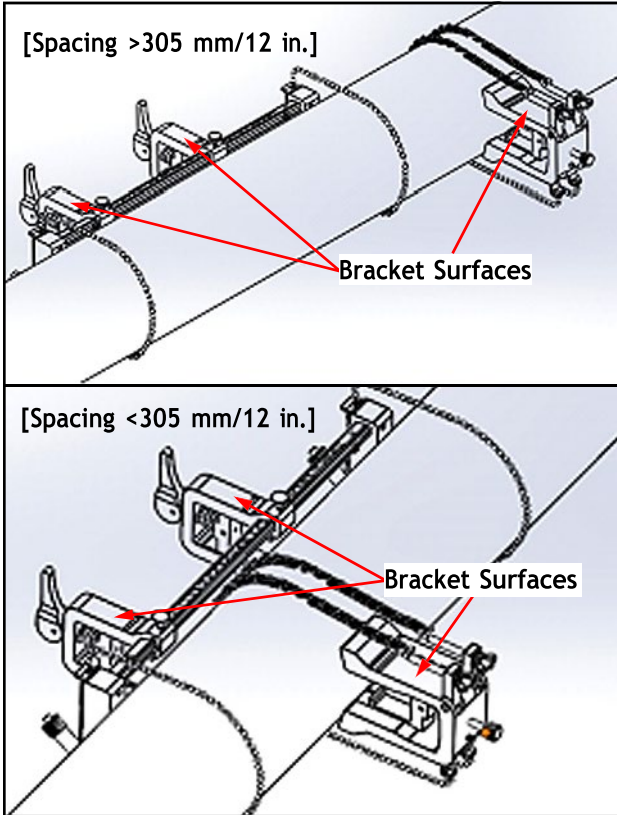

Figure 28: Yoke Rotated into Horizontal Position

5. Ensure that the top surfaces of the yoke bracket and the clamping fixture brackets lie precisely in the same horizontal plane (see Figure 28 above). Place the fixed clamp in the clamping fixture at zero on the scale.

Note: If the required axial spacing is 305–375 mm/12 in.–14.8 in., place the fixed clamp at 100/4 in. on the scale instead of zero.

2.5.6b Odd-Traverse Installations (cont.)

6. Set the yoke axial position as follows:
 - Spacing >305 mm/12 in. (435 mm/17.13 in. is used as an example): Measure the required 435 mm/17.13 in. distance from the edge of the fixed clamp to the marked line on the yoke (see Figure 29 below).

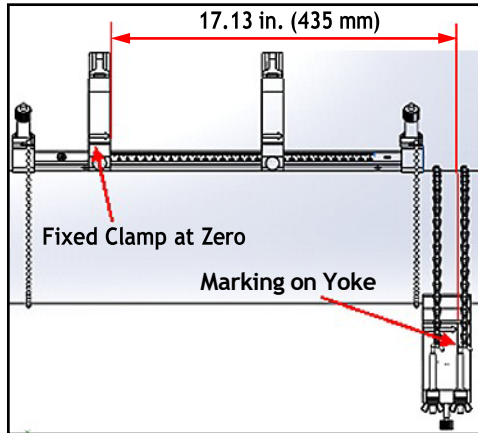

Figure 29: Yoke Set at 435 mm/17.13 in.

- Spacing <305 mm (120 mm/4.72 in. is used as an example): Measure the required 120 mm/4.72 in. distance from the edge of the fixed clamp to the marked line on the yoke (see Figure 30 below).

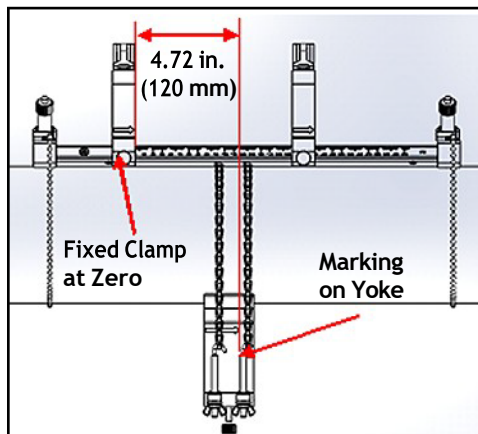

Figure 30: Yoke Set at 120 mm/4.72 in.

2.5.6b Odd-Traversal Installations (cont.)

7. Tighten the nuts to secure the yoke to the pipe (see Figure 31 below).

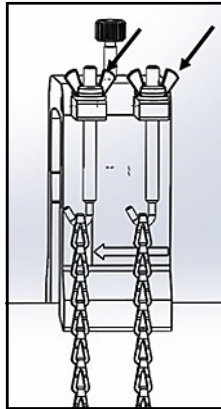

Figure 31: Secure the Yoke

8. Loosen the yoke screw. Then, apply couplant to the transducer face and insert the transducer into the yoke, as shown in Figure 32 below.

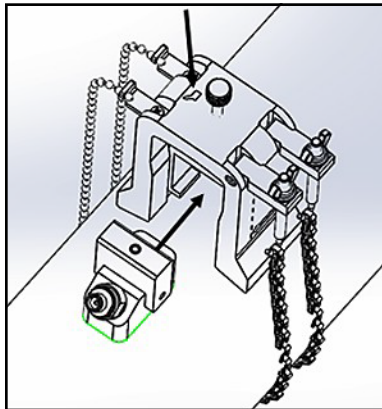

Figure 32: Insert Transducer into Yoke

2.5.6b Odd-Traversal Installations (cont.)

9. Tighten the yoke screw until the transducer firmly contacts the pipe. Your completed odd-traverse installation should look like Figure 33 below.

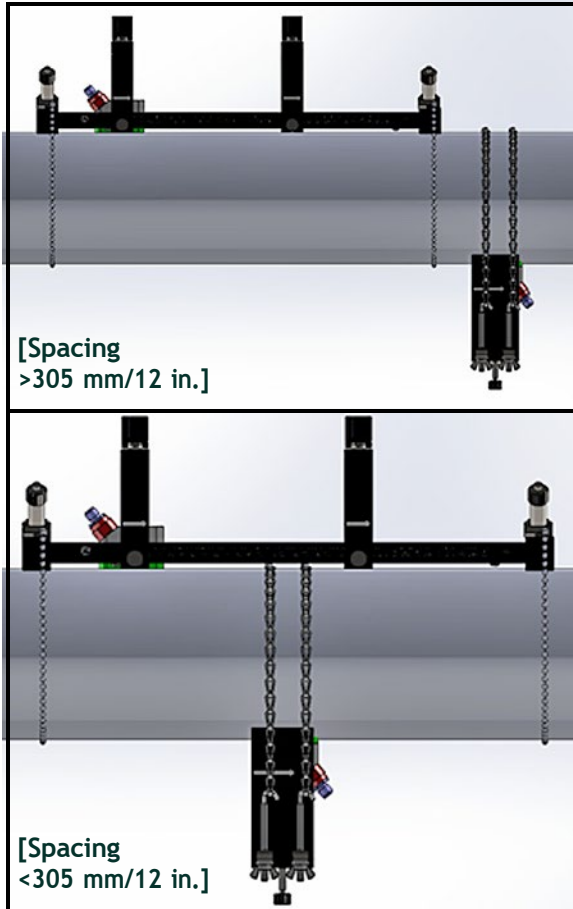

Figure 33: Completed Odd-Traversal Installation (Top View)

2.5.6c Even-Traversal Installations (Spacing >305 mm/12 in.)

For an even-traverse installation with a transducer spacing >305 mm/12 in., the separate yoke included with the clamp-on fixture is required (see Figure 34 below).

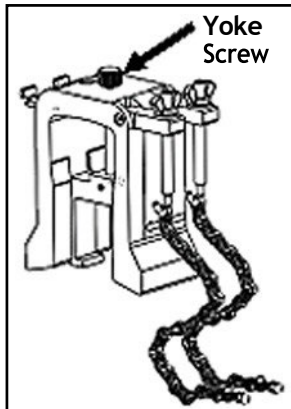

Figure 34: Yoke for Even-Traversal With $S > 305$ mm/12 in.

Important: The clamping fixture must be installed before the yoke (see "Mounting the PT9 Clamp-On Fixture" on page 9). You must determine the required transducer spacing before proceeding (see "Viewing the Transducer Spacing" on page 79).

To install the yoke, complete the following steps:

1. Loosen the yoke screw at least 25 mm/1 in. (all the way for pipes <50 mm/2 in.) and loosen the J-Hooks all the way (see Figure 25 below).

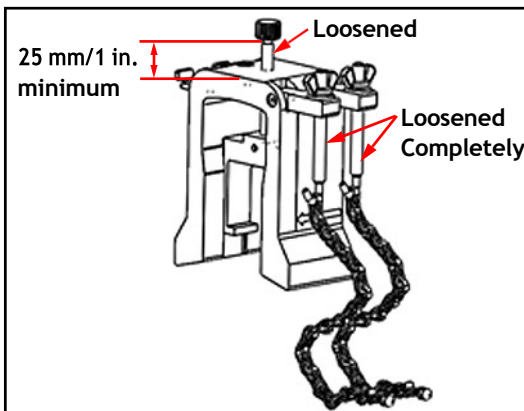

Figure 35: Loosened Yoke Screw and J-Hooks

2.5.6c Even-Traversal Installations (Spacing > 305 mm/12 in.) (cont.)

2. Place the yoke on the top of the pipe (see Figure 36 below). If the required transducer spacing is < 305 mm/12 in., the yoke chain must be placed within the clamping fixture as shown.

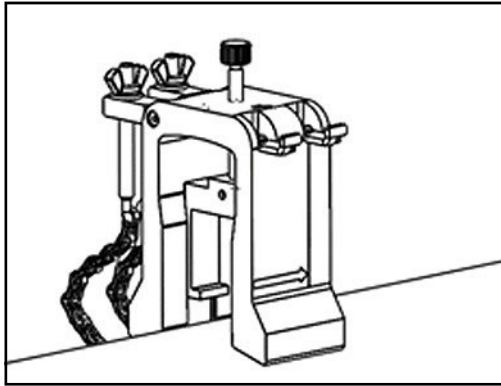

Figure 36: Yoke Placement On Top of Pipe

3. Wrap the yoke chains around the pipe and secure them to the yoke bracket, as shown in Figure 37 below.

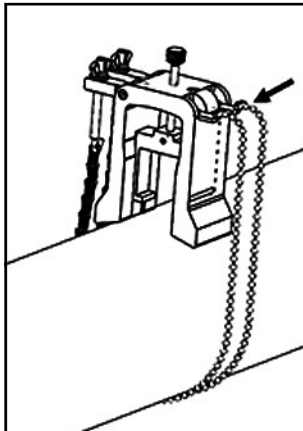

Figure 37: Yoke Chains Secured

2.5.6c Even- Traverse Installations (Spacing >305 mm/12 in.) (cont.)

4. Rotate the yoke until it is located in a horizontal position on the same side of the pipe as the previously installed clamping fixture, as shown in Figure 38 below.

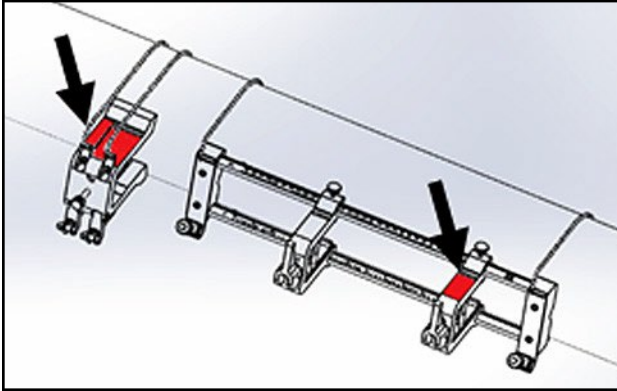

Figure 38: Yoke Rotated into Horizontal Position

5. Ensure that the top surfaces of the yoke bracket and the fixed clamping fixture bracket lie precisely in the same horizontal plane (see Figure 38 above).

2.5.6c Even- Traverse Installations (Spacing > 305 mm/12 in.) (cont.)

- Place the fixed clamp in the clamping fixture at zero on the scale. As an example, if the required transducer spacing is 435 mm/17.13 in., measure the required 435 mm/17.13 in. distance from the edge of the fixed clamp to the marked line on the yoke (see Figure 39 below).

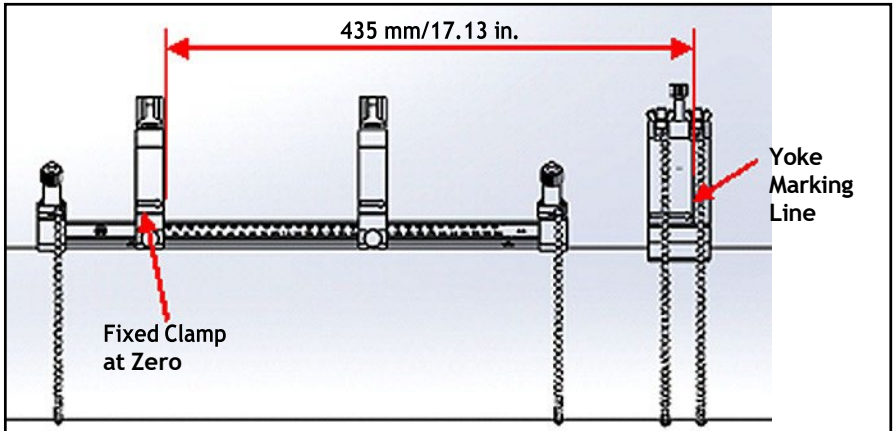

Figure 39: Yoke Set at 435 mm/17.13 in.

- Tighten the nuts to secure the yoke to the pipe (see Figure 40 below).

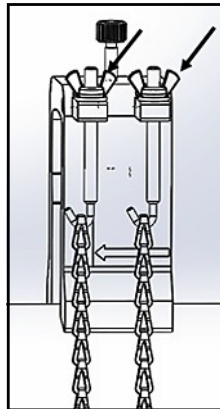

Figure 40: Secure the Yoke

2.5.6c Even-Traversal Installations (Spacing > 305 mm/12 in.) (cont.)

8. Loosen the yoke screw. Then, apply couplant to the transducer face and insert the transducer into the yoke, as shown in Figure 41 below.

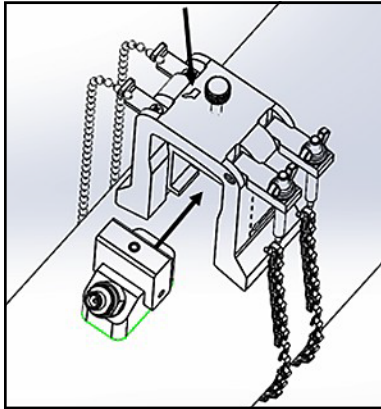

Figure 41: Insert Transducer into Yoke

9. Tighten the yoke screw until the transducer firmly contacts the pipe. Your completed odd-traverse installation should look like Figure 42 below.

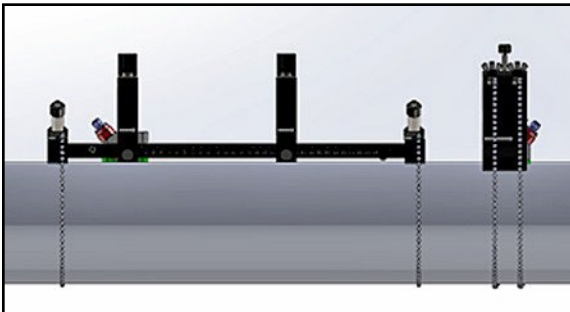

Figure 42: Completed Installation (Top View)

2.6 Making the Electrical Connections

Before taking measurements with the PT900, you must make all the necessary cable connections to the transmitter. To wire your transmitter, complete the following sections:

- Connecting the Line Power (see page 33)
- Connecting the Transducers (see page 35)
- Connecting the Digital Output (see page 36)
- Connecting the Analog Inputs and Output (see page 37)
- Using the USB Port (see page 38)
- Using the Bluetooth Wireless Interface (see page 38)

Note: For basic operation, you only need to connect the Transducer cables. The I/O connections are required only if you intend to use those features.

After the PT900 is completely wired, proceed to Chapter 3, Initial Setup, to configure the meter for operation.

2.6.1 Connecting the Line Power

An example of the PT900 transmitter product label is shown in Figure 43 below. Be sure to power the transmitter only with the voltage specified on the label.

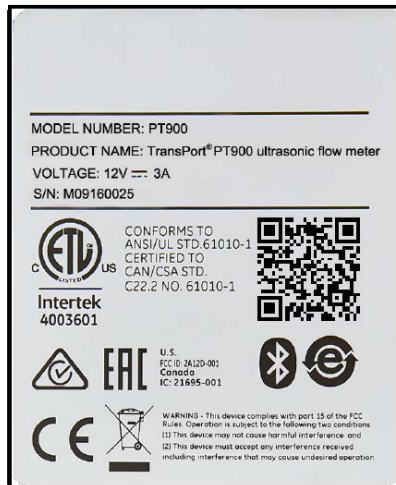

Figure 43: PT900 Transmitter Label



WARNING! To ensure the safe operation, you must install and operate the PT900 as described in this manual. Also, be sure to follow all applicable safety codes and regulations for installing electrical equipment in your area. The PT900 and its transducers are designed for use only in general-purpose locations.

The PT900 is powered by either a 100-240 VAC wall mount plug-in module or by a Lithium Ion high-energy rechargeable smart battery pack. In either case, you must connect the power cord to the Power connector (see Figure 44 below).

In normal operation mode, the PT900 can be operated with a battery pack in the transmitter. When you receive the PT900, the battery pack is not fully charged. To charge the battery pack, you must use an external power adapter with an input rating of 100-240VAC and output rating of 12VDC. When the AC power adapter is connected to the transmitter, the battery LED will start flashing, which indicates that the battery is charging. When the battery LED is continuously On, it indicates that the battery is at full charge. When the external power adapter is removed, the battery LED will be Off.



Figure 44: Transmitter Power Connection (Right Side)



WARNING! To ensure safe operation, do not turn the PT900 On while the battery pack is being charged by an external power adapter connected to a mains voltage of greater than 150VAC. If the PT900 is turned On in such a situation, make sure that you do not touch the transducer connectors.

2.6.2 Connecting the Transducers

To connect the transducers, see Figure 45 below and proceed as follows:

1. Connect the cables from each of the transducers to the transmitter:
 - a. Connect the transducer cable with the UP label on the cable connector to the transmitter connector labeled UP.
 - b. Connect the transducer cable with the DN label on the cable connector to the transmitter connector labeled DN.
2. If your transmitter is configured for two channels, connect the second transducer pair by repeating the above step.
3. Properly configure the transmitter to work properly with your specific transducer type. See “Programming the Transducer Parameters” on page 74 for instructions.

Important: Be sure to insert the cable connectors straight into the transmitter connectors to avoid damaging the connectors.



Figure 45: Transducer Connections (Bottom)

2.6.3 Connecting the Digital Output

The PT900 provides one RS485/Modbus digital output and also supports a digital frequency/pulse output and a totalizer/control gate input. Connect the digital output as shown in Figure 46 below (see the cable to the right). The pin numbers for the connector and the color code for the standard input/output cable are shown in Table 1 below.

Table 1: DIO Cable Wiring Diagram

Connection	Pin #	Color	Description
RS484-	1	Black	RS485/Modbus Negative
RS485+	2	Red	RS485/Modbus Positive
RS485 COM	3	Green	RS485/Modbus Common
DIO	4	White	Digital IO Positive
DRTN	5	Yellow	Digital IO Return
SHD	6	Silver	Cable Shield



Figure 46: Transmitter I/O Connections (Right Side)

2.6.4 Connecting the Analog Inputs and Output

The PT900 provides one 0/4-20 mA analog current output and two 4-20 mA analog inputs, with a switchable 16 V supply for loop-powered temperature transmitters. Connect the analog inputs and output as shown in Figure 46 on page 36 (see the cable to the left). The pin numbers for the connector and the color code for the standard input/output cable are shown in Table 2 below.

Table 2: AIO Cable Wiring Diagram

Connection	Pin #	Color	Description
Aout+	1	Red	4-20mA OUTPUT
Aout-	2	Black	4-20mA RETURN
16VDC	3	Blue	+16VDC OUTPUT
ARTN	4	Yellow	ANALOG INPUTS RETURN
AIN1	5	Orange	ANALOG INPUT 1
AIN2	6	Green	ANALOG INPUT 2
SHD	7	Silver	Cable Shield

Important: The Analog Output is an active mode type. Do not supply a 24V supply to this circuit, as the circuit is powered by the transmitter.

2.6.5 Connecting the Energy Cables

The AIO port is commonly used for connecting a pair of energy cables to permit energy measurements (see Figure 47 below).



Figure 47: Energy Cable Connection (Right Side)

2.6.6 Using the USB Port

The PT900 provides one USB2.0 full-speed interface. The receptacle is a micro-USB Type B connector, as shown in Figure 48 below. Data logs and other information from the transmitter's embedded storage can be uploaded to a PC via the USB port. In addition, the transmitter's configuration files can be changed directly via the USB port.



Figure 48: Transmitter USB Connector (Left Side)

2.6.7 Using the Bluetooth Wireless Interface

The PT900 comes equipped with an internal Bluetooth transceiver that enables wireless communication between the transmitter and Bluetooth-enabled tablets. The transmitter can then be configured by the PT900 APP software installed on a tablet connected via the wireless Bluetooth interface. For more information on the APP, see Chapter 3, Initial Setup.

2.7 Caring for the PT900 Batteries

The PT900 comes with a self-contained, built-in, rechargeable battery pack to support portable operation. For optimum performance, these batteries require a minimum of maintenance.



CAUTION! Use only Panametrics-approved batteries and desktop chargers, which are designed to maximize battery life. Using other batteries or chargers voids your warranty and may cause damage to the equipment.



CAUTION! For CE compliance, the PT900 is classified as a battery-powered device, and it is not to be operated with the AC power adapter connected.

2.7.1 Charging and Storing the Batteries

When you receive the PT900, you will need to initially charge the batteries. Also, the batteries may need to be recharged if they have not been used for a long period of time. The batteries must be charged for up to 3 hours to go from 0% (totally depleted) to 100% (fully charged). When fully charged, the batteries provide 18–20 hours of continuous operation. An internal battery gauge indicates the remaining power in the battery.

To charge the battery, simply plug the AC power adapter cord into the power jack (see Figure 44 on page 34) and be sure the battery pack is installed in the transmitter (see “Installing a Battery Pack in the Transmitter” on page 6). Whether the PT900 is On or Off, when the AC power adapter is plugged into line voltage the internal transmitter battery charger automatically charges the battery. The battery LEDs (see Figure 49 below) indicate the battery charging status.

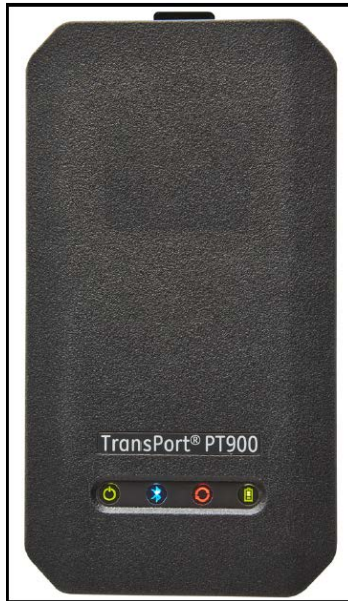

Figure 49: Battery Charging Status LEDs

For optimal run time, charge the batteries only in temperatures from 32°F to 113°F (0°C to 45°C). Otherwise, the batteries will not be properly charged and will have significantly reduced run time. Store the batteries at temperatures ranging from -4°F to 122°F (-20°C to 50°C). The recommended storage temperature range is -4°F to 77°F (-20°C to 25°C). Extended storage at temperatures above 104°F (40°C) could degrade battery performance and service life.

2.7.2 Replacing the Batteries



CAUTION! Replace the PT900 batteries only with the specified rechargeable batteries. The battery charges even when the unit is Off. Do not attempt to recharge non-rechargeable batteries.

To replace the battery pack:

1. Remove the rubber boot from the transmitter.
2. Open the panel on the back of the transmitter (see Figure 50 below).
3. Disconnect and remove the old battery pack.
4. Install the new battery pack.
5. Reinstall the panel and the rubber boot on the transmitter.



Figure 50: Battery Panel Location

2.7.3 Disposing of the Batteries



CAUTION! Never dispose of the batteries by incineration. Do not attempt to disassemble or short-circuit the batteries. For safety, do not handle a damaged or leaking battery.



CAUTION! Be sure to dispose of your batteries properly. In some areas, battery disposal in business or household trash may be prohibited. For safe disposal options, contact your nearest Panametrics authorized service center.

2.8 Powering On and Off

To operate the PT900, the power cord must be plugged into line voltage or the battery pack must be charged as described in the previous sections.



CAUTION! For CE compliance, the PT900 is classified as a battery-powered device, and it is not to be operated with the AC power adapter connected. To comply with CE certification, unplug the AC power adapter before operating the PT900.



WARNING! If the PT900 fails the backup battery test, you must send the unit back to the factory for a battery replacement. Make sure you keep the battery charged until you are ready to ship the unit back to the factory. Before shipping, print out all of the log and site data, or transfer it to your PC. Never dispose of the battery by incineration. Do not attempt to disassemble or short-circuit the battery pack. For safety, do not handle a damaged or leaking battery.

2.8 Powering On and Off (cont.)

To turn the PT900 On, press the Power On/Off button on the top of the transmitter (see Figure 51 below) for about 3 seconds. Initially, only the Green Power LED shows solid On. However, after the system powers up completely, all the LEDs show solid On.

To turn the PT900 Off, press the Power On/Off button on the top of the transmitter (see Figure 51 below) for about 3 seconds. All of the LEDs will turn Off.



Figure 51: Transmitter Power Button (Top)

2.9 PT900 LED Indicators

The four colored LEDs on the front of the PT900 transmitter (see Figure 52 below) provide real time information on the meter status. See the next page for details.

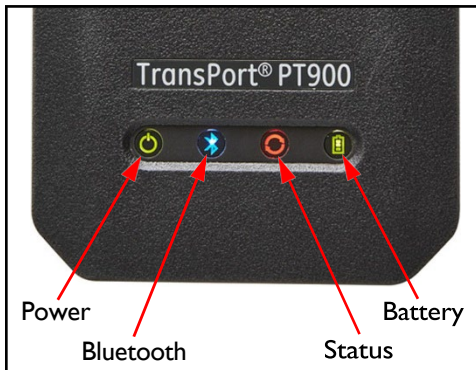

Figure 52: Transmitter LEDs (Front)

2.9.1 Power LED

- Solid Green light when the meter is powered On
- No light when the meter is Off
- Blinking Green light when the meter is in power save mode

2.9.2 Bluetooth LED

- Solid Blue light when Bluetooth® is linked to a transmitter
- Blinking Blue light when Bluetooth® is in the click-button to confirm pairing process
- Solid Red light when the meter is on and Bluetooth® is idle or is not linked to a transmitter
- No light when Bluetooth® is in configuration mode

2.9.3 Status LED

- Solid Green light when the meter is in measure mode without any errors
- Red light when an error occurs while the meter is in measure mode
- No light when the meter is in configure mode

2.9.4 Battery LED

- Solid Green light when the battery is fully charged (>99%), but the AC adapter is connected
- Solid Green light when the battery level is high (>20%), but the AC adapter is not connected
- Blinking Green light when the battery is not fully charged, but it is charging with the AC adapter connected
- Red light when the battery level is low (20%) and the battery needs to be charged immediately
- Blinking Red light when the battery level is low (10%) and the meter will be out of power soon
- Light off when the meter is On, but the battery is completely discharged and the AC adapter is connected

[no content intended for this page]

Chapter 3. Initial Setup

3.1 Introduction

This chapter provides instructions for programming the PT900 flow meter via the tablet APP prior to initial operation.

3.2 Charging the PT900 Transmitter and Tablet

Before proceeding, make sure that both the PT900 Transmitter and the Tablet are fully charged. The AC power adapters are shipped in the carry case. If either the transmitter or the tablet cannot be powered **On** after charging, contact your Panametrics representative or visit www.panametrics.com for transmitter assistance or contact the tablet manufacturer for tablet assistance.

3.3 Installing or Updating the PT900 APP

The instructions in the following sections explain the procedures for downloading the current version of the PT900 APP and installing it on your tablet.

3.3.1 Checking the APP Version

To check the APP version currently on your tablet, click on the About option in the Help menu to open a screen similar to Figure 53 below. This screen displays general information about the PT900. This information includes: model name, instrument type, software version, and the copyright year of the APP.

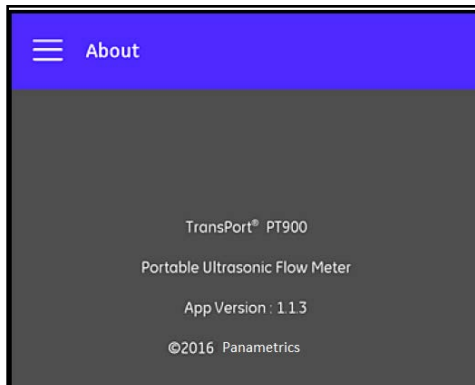

Figure 53: The About Screen

3.3.2 Installing or Updating the PT900 Android and iOS APP

Update your existing PT900 APP from one of the below options:

Android App

- **Google Play Store:** To obtain a newer version of the APP from Google Play Store, search for “Transport PT900” and install it. Google Play Store is the preferred method of installation because updates will automatically be loaded to your tablet with the latest version of the application.
- **QR Code or Panametrics Website:** To obtain a newer version of the APP, scan the QR Code in Figure 54 below.



Figure 54: QR Code

Alternatively, download the latest version of the APP from the Panametrics website, go to the below URL and search for “TransPort PT900” <https://www.industrial.ai/download-center>

- **SD Card:** To obtain a newer version of the APP from an SD card, plug the SD card directly into the Tablet. Then, select the APK file from the SD folder.

iOS App

- **Minimum iOS Device Requirements:** Device should have
 - BLE 4.0 and above
 - iOS version 11.0 and above
 - Capacity: 16GB and above
- **Apple App Store:** To obtain a newer version of the APP from Apple App Store, search for “Transport PT900” and install it. Apple App Store is the only method to install the iOS application and updates will automatically be loaded to your tablet with the latest version of the application.

3.3.3 Installing the Tablet APP from the SD Card (Applicable only to Android APP)

To install the APP, complete the following steps:

1. Open the “My Files” folder on the tablet screen and select the APP from the SD folder (see Figure 55 below).

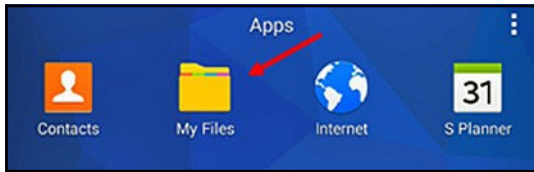

Figure 55: The “My Files” Folder

2. In the tablet settings, enable the security option to allow the installation of software from “Unknown sources” for this installation only (see Figure 56 below).

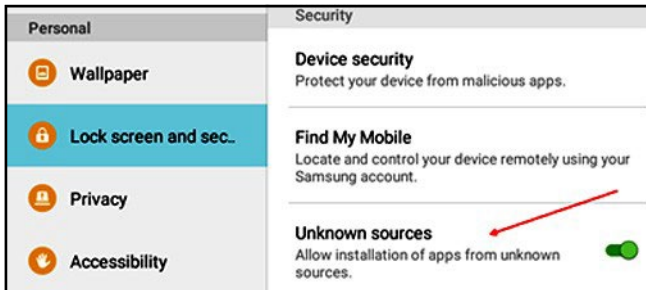

Figure 56: Security Settings

3.3.3 Installing the Tablet APP from the SD Card (cont.)

3. Click on the APK file, and the Android operating system will verify the checksum and signature for the file. Depending on whether this is an initial installation or an update installation, you will see one of the screens shown in Figure 57 below. Click INSTALL to begin the installation.

Note: If the file signature is not verified, the APP will be treated by the Android operating system as an unrecognized APP.

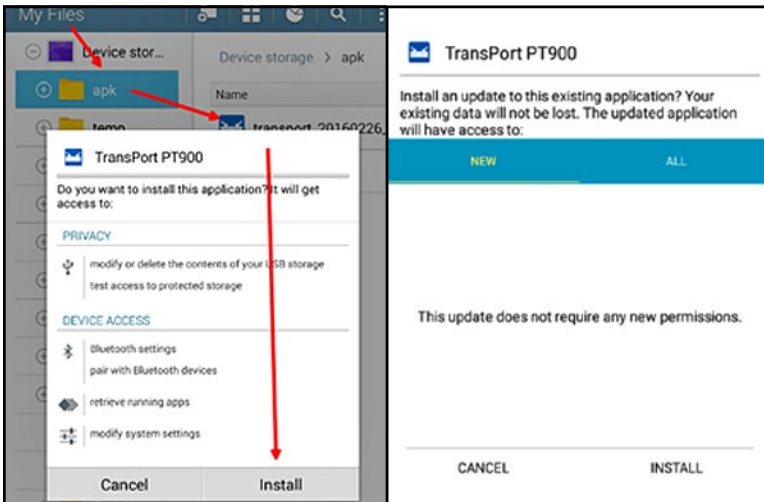

Figure 57: Initial (Left) and Update (Right) Installation Screens

3.4 Pairing the Tablet and the Transmitter

To set up the APP and pair with the PT900 transmitter, complete the following steps:

1. After the APP has been downloaded to your tablet, find the icon shown in Figure 58 below on the tablet APPS and click on it to launch the APP.



Figure 58: PT900 APP Icon

2. While the APP is loading, you should see the initialization screen shown in Figure 59 below.



Figure 59: APP Loading Screen

3.4 Setting Up the PT900 APP (cont.)

- At the screen shown in Figure 60 below, select the desired language for the APP and click OK.

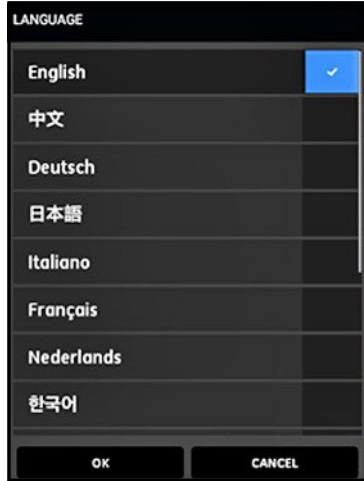

Figure 60: PT900 APP Language Options

- At the License Agreement screen (see Figure 61 below), read the agreement and then click AGREE to continue with the APP installation or click CANCEL to stop the APP installation.



Figure 61: PT900 APP License Agreement

3.4 Setting Up the PT900 APP (cont.)

- At the Registration screen (see Figure 62 below), click OK to register your PT900 or click CANCEL to skip the registration.

Note: If you skip the registration, the screen will popup as a reminder the first five times you launch the APP and then it will never appear again.

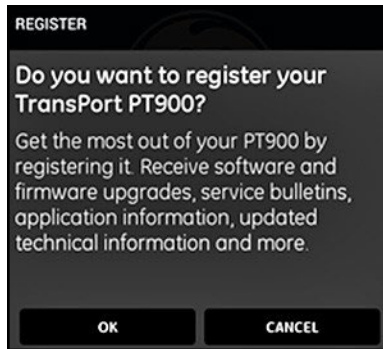

Figure 62: PT900 Registration

- After the APP finishes loading, the default Transmitter list is displayed. During initial installation, this list is empty (see Figure 63 below).



Figure 63: Initial Transmitter List

3.4 Setting Up the PT900 APP (cont.)

7. To connect to a new PT900 transmitter, click SCAN. Pairing steps are different for Android and iOS application. For Android, follow the below steps (8 & 9) and for iOS, follow the steps 10 & 11.

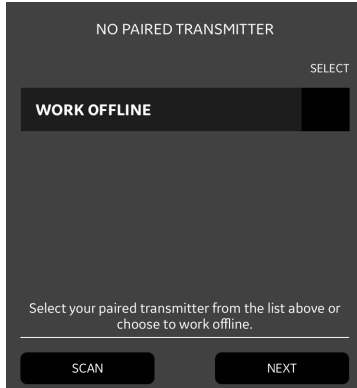

Figure 64: Scanning Transmitter

Note: Your PT900 transmitter is identified by the serial number on its label (see Figure 65 below).



Figure 65: Transmitter Serial Number

- In Android, APP will search for all available transmitters via Bluetooth. After the scan has been completed, any new transmitters which were found are listed in the AVAILABLE DEVICES section of the tablet screen (see red arrow in Figure 66 below). Click on your transmitter to pair it with the tablet via Bluetooth.

Important: Although Bluetooth is installed in many devices, the PT900 APP is designed to filter out all devices except those with names of the form PT900-Mxxxxxxx.

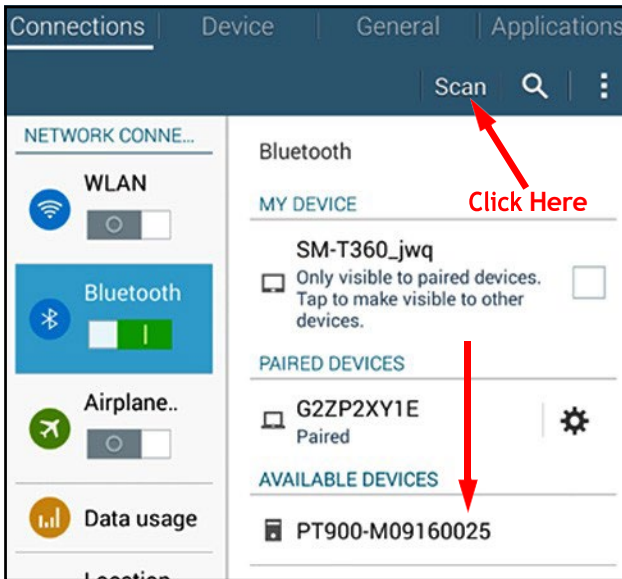

Figure 66: Available Devices List

- During the pairing process, PT900 security features require the user to confirm the pairing (see Figure 67 below). When the Bluetooth pairing request appears on the tablet (ignore the random passkey), click OK to continue. Then, confirm that the blue LED on the transmitter is flashing and click the transmitter power button.

Important: The pairing is completed only after it is confirmed at both the tablet and the transmitter. Otherwise, the pairing will fail.



Figure 67: Confirm the Pairing

For iOS:

10. In iOS, APP will search for all available transmitters via Bluetooth. After the scan has been completed, any new transmitters which were found are listed in the AVAILABLE DEVICES section of the tablet screen. Click on your transmitter to pair it with the tablet via Bluetooth.



Figure 68: Available Devices List

Note: In Android, if Bluetooth is turned off then app can turn on the Bluetooth programmatically but in iOS, there is no control over the Bluetooth to turn on from application side.

Note: If you try to pair iPhone with firmware below 1.2.1, then you may see a connection error popup. In such case after upgrading the firmware to 1.2.1 or above (supports iOS and android), turn the bluetooth off/on on your device settings to start the connection again.

11. During the pairing process, PT900 security features require the user to confirm the pairing (see Figure 69 below). When the Bluetooth pairing request appears on the tablet, enter the passkey and click Pair. Then, confirm that the blue LED on the transmitter is flashing and click the transmitter power button within 10s. Passkey for this device is 843278.

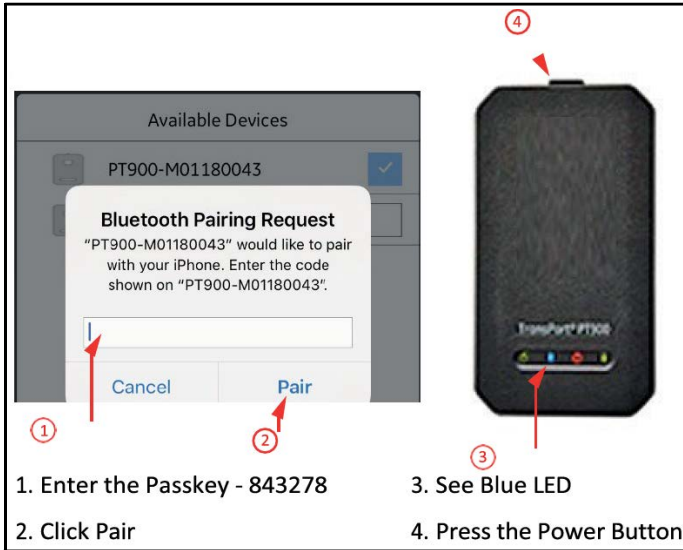

Figure 69: Confirm the Pairing

- Click the BACK button on the tablet to return to the PT900 APP main menu. Then, select your PT900 transmitter in the TRANSMITTERS PAIRED list and click NEXT to open the Main Menu. For example, the PT900-M09160025 transmitter is selected from the list in Figure 70 below.

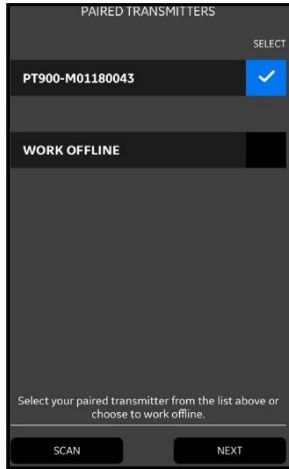

Figure 70: Paired Transmitters List

- Note:** If desired, you may simulate the APP operation without connecting to the transmitter. To do so, click the WORK OFFLINE option in Figure 70 above.
- Note:** The transmitter can hold only a maximum of four paired devices at a time. When you try to pair more than four devices, then the first paired device will be automatically removed from the transmitter to allow the new device for pairing.

13. In iOS, if the power button is not pressed within 10s, then the pairing process will fail at the transmitter end. Though it is not paired, this unpaired device will also be displayed in the transmitter paired list. But when you try to connect, below error pop-up will appear.

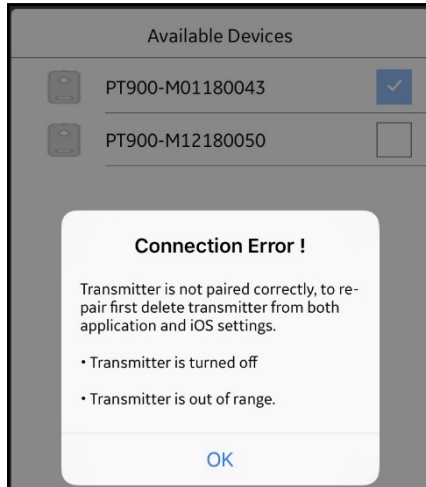

Figure 71: Connection Error

Important: To pair this transmitter again, user needs to remove the device manually from PT900 APP and iPhone. To remove the device, refer to “Removing paired devices from PT900 APP” on page 58 and “Removing paired devices from iPhone/Tablet” on page 59.

3.4.1 Removing paired devices from PT900 APP

1. Select the transmitter from the list that you want to remove and click Edit button in the top right of the below screen.

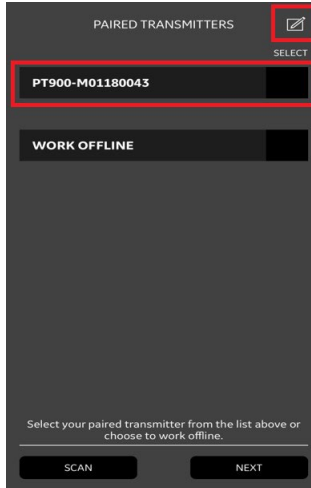

Figure 72: Paired Transmitter Screen

2. Below screen appears. Click Delete icon next to the transmitter name.

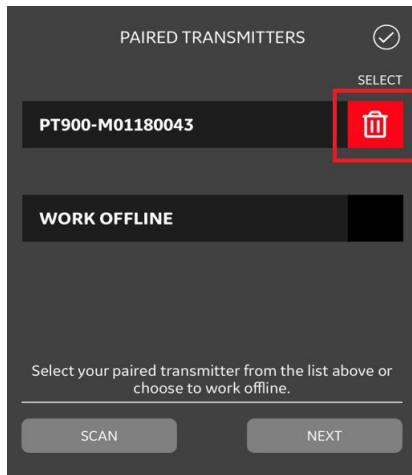

Figure 73: Delete icon

3. Click OK on the pop-up that appears to confirm the deletion. Now the device will be removed from the APP list.

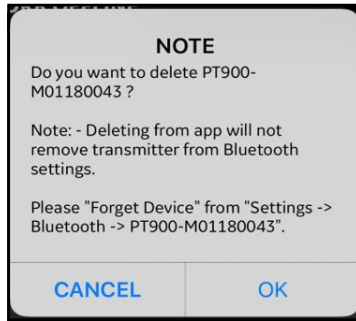

Figure 74: Pop-up Screen

3.4.2 Removing paired devices from iPhone/Tablet

1. On iPhone/tablet Go to Settings > Bluetooth.
2. Find the device that you want to remove and click ⓘ icon next to it.

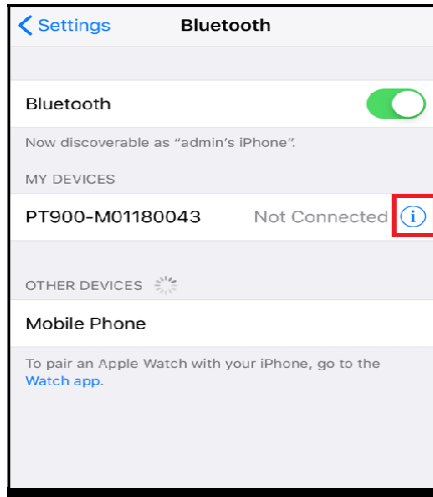

Figure 75: iPhone Bluetooth Settings Screen

3. Click Forget This Device on the below screen.

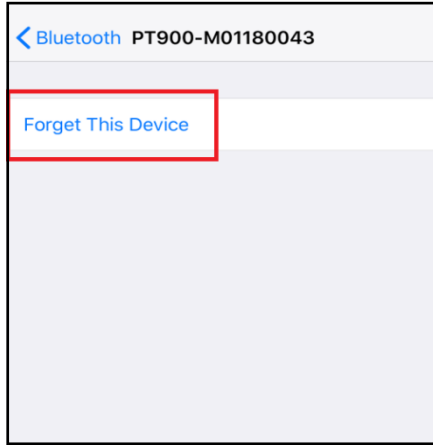

Figure 76: Bluetooth Settings Screen

4. Click Forget Device again on the below screen to confirm the deletion.
Now the device will be removed from the iPhone.

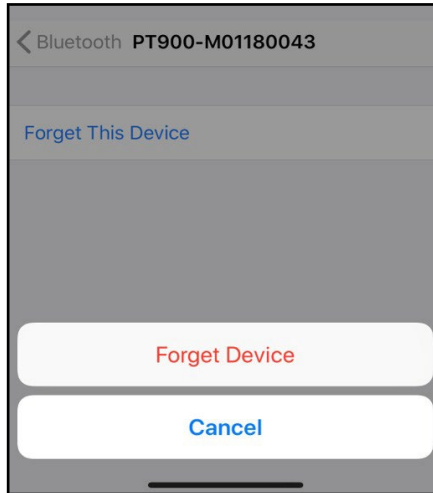

Figure 77: Confirm the Deletion

3.5 Using the APP Main Menu and the Slide Menu

3.5.1 The Main Menu

After successfully installing the APP on the tablet and pairing a PT900 transmitter with the tablet, the initial APP screen is the Main Menu shown in Figure 78 below.

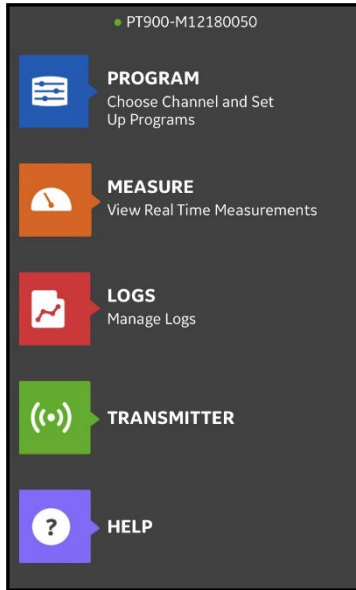

Figure 78: APP Main Menu Screen

The available options in the APP Main Menu are:

- **PROGRAM**, which is used for selecting and configuring a channel.
- **MEASURE**, which is used for viewing real time measurements, error reports and diagnostics information.
- **LOGS**, which is used for setting up log files and managing logs stored in the PT900 transmitter.
- **TRANSMITTER**, which is used get information about transmitter, performing calibrations, setting the error limits and saving the wave sample.
- **HELP**, which is used for accessing detailed information and instructions for your PT900.

3.5.2 The Slide Menu (Applicable only to Android)

In Android, as an alternative to the Main Menu discussed in the previous section, you may use the Slide Menu shown in Figure 79 below.

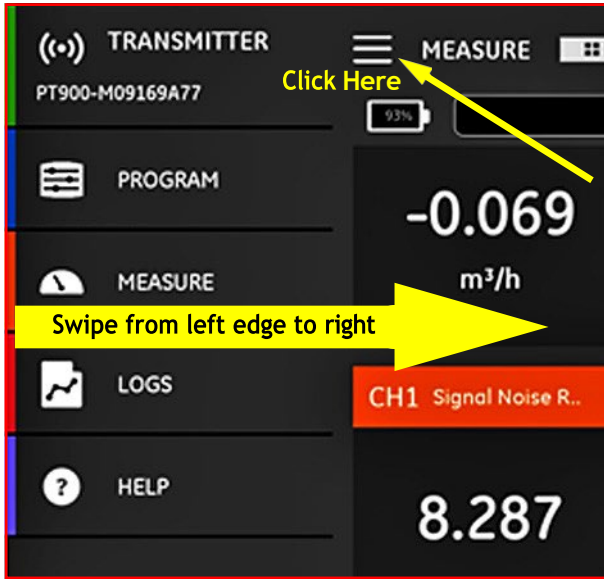



Figure 79: APP Slide Menu Screen

To access the Slide Menu, either click the  icon in the top left corner of the screen or swipe across the screen from the left edge to the right. The available options in the APP Slide Menu are:

- **PROGRAM**, which is used for selecting and configuring a channel.
- **MEASURE**, which is used for viewing real time measurements, error reports and diagnostics information.
- **LOGS**, which is used for setting up log files and managing logs stored in the PT900 transmitter.
- **HELP**, which is used for accessing detailed information and instructions for your PT900.

Note: In iOS, App main menu will appear if you swipe left edge to right.

Chapter 4. Programming

4.1 Configuring the Units of Measurement

The UNITS OF MEASUREMENT menu (see Figure 80 below) allows the user to select the measurement units displayed by the PT900 in all of its screens.

Note: Because the choice of Metric or English units is reflected in all other menu screens, this menu should be programmed first.

The screenshot shows the 'UNITS OF MEASUREMENT' menu. At the top, it says 'Select your units of measurement.' There is a toggle switch for 'Metric' (which is turned on) and 'English'. Below this, there are several sections, each with a label and a dropdown menu for selecting units:

- Velocity:** m/s
- Density:** kg/m³
- Acceleration:** m/s²
- Temperature:** °C
- Custom Enthalpy:** kJ/kg°C
- Energy:** kWh
- Power:** kCal/s
- Standard Volumetric:** SL/s
- Actual Volumetric:** m³/h
- Diameter:** mm
- Mass:** kg/s
- Totalizer:** Totalizer-Actual V...
- Batch Totalizer Time:** s

At the bottom of the menu are two buttons: 'OK' and 'CANCEL'.

Figure 80: The Units of Measurement Menu

4.1 Configuring the Units of Measurement (cont.)

From the APP main menu, click Unit Options under the PROGRAM menu. This will open the UNITS OF MEASUREMENT menu shown in Figure 80 on page 63.

To program the UNITS OF MEASUREMENT, complete the following steps:

1. Move the slide switch at the top of the menu to either Metric or English to select the desired PT900 global measurement units system.
2. Based on your selection above, the units for all of the PT900 measurement parameters will be automatically populated with default units.
 - a. Some of the parameters have only one units of measure choice available. The text boxes for these parameters are grayed out, and the default units cannot be changed.
 - b. Some of the parameters have multiple units of measure choices available. The text boxes for these parameters are active, and the default units can be changed by opening the drop-down list and selecting the desired units.
3. After you have completed your programming, click the OK button to save your choices or click the CANCEL button to discard the changes.

4.2 Configuring a Channel

Selecting the PROGRAM>Channel option on the APP screen (see Figure 81 below) enables you to set up a channel for measuring flow rate. The PT900 supports up to two channels, channel 1 and channel 2. They are programmed individually, and the programmed information can be saved in a PRESETS file.

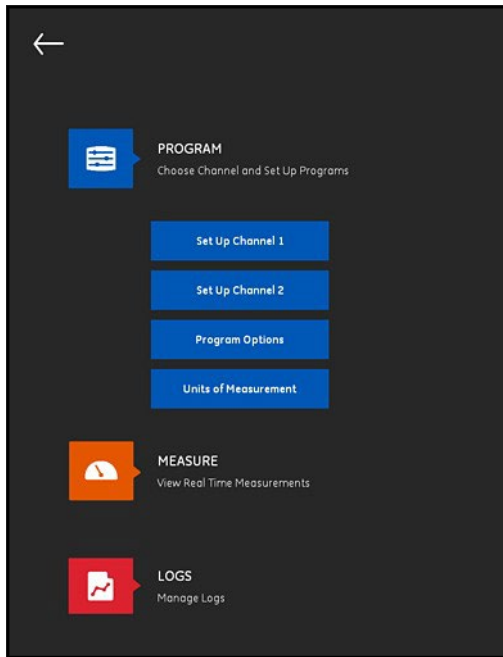

Figure 81: The Program Channel Menu

To completely configure a channel, the following menus must be programmed:

- **PIPE** (see “Programming the PIPE Menu” on page 67)
- **FLUID** (see “Programming the FLUID Menu” on page 70)
- **TRANSDUCERS** (see “Programming the TRANSDUCERS Menu” on page 73)
- **PLACEMENT** (see “Programming the PLACEMENT Menu” on page 78)

4.2 Configuring a Channel (cont.)

Using Channel 1 as an example, refer to Figure 82 below and complete the following steps:

1. Change the channel status from Off to On. This will not only activate the channel, but it will also activate the two programming buttons.
2. If the other channel has already been programmed, click the COPY CH button to copy all programming data from the other channel to the current channel. In this example, it will copy the Channel 2 data into Channel 1 to simplify the programming.
3. After the current channel has been programmed, click the PRESETS button to save the programming data to a file stored in the PT900 transmitter memory. These site data files may be uploaded to the APP via the USB link the next time the PT900 is installed at the same site.

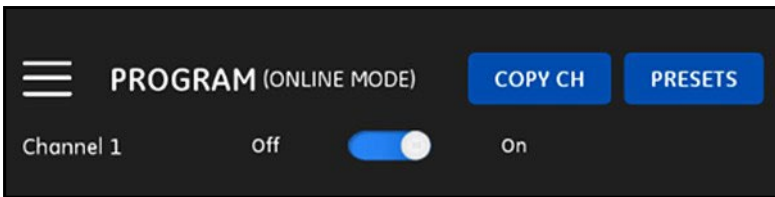

Figure 82: Channel 1 Programming (Android Screen)

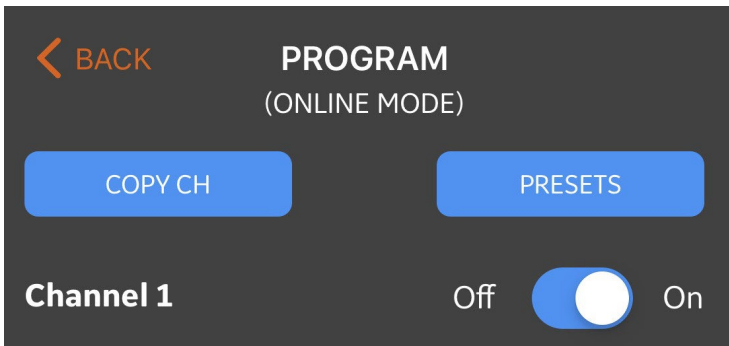

Figure 83: Channel 1 Programming (iOS Screen)

4.3 Programming the PIPE Menu

The PIPE menu allows the user to specify all pipe parameters that are required to ensure accurate ultrasonic flow rate measurements. An example of this menu is shown in Figure 84 below. See the following sub-sections for the options available in programming the various pipe parameters.

Note: The measurement units used for all pipe parameters in these menus depend on the choices made in the UNITS OF MEASUREMENT menu.

The screenshot shows the 'PROGRAM (ONLINE MODE)' interface with the 'PIPE' menu selected. The interface includes a 'Channel 1' indicator, a power toggle (Off/On), and buttons for 'COPY CH' and 'PRESETS'. The 'PIPE' menu is divided into four sections: PIPE, FLUID, TRANSDUCERS, and PLACEMENT. The 'PIPE' section contains the following parameters:

- PIPE MATERIAL:** Steel (Carbon)
- PIPE SOUND SPEED:** 3230.0 m/s
- PIPE STANDARD:** ANSI
- NOMINAL:** 1/8
- SCHEDULE:** 40
- OUTER DIAMETER:** 10.287 mm
- WALL THICKNESS:** 1.727 mm
- LINING:** Yes
- LINING MATERIAL:** Other
- LINING SOUND SPEED:** 2000.0 m/s
- LINING THICKNESS:** 0.0 mm

Figure 84: The PIPE Menu

4.3.1 Pipe Materials

From the drop-down list of pipe materials supported by the PT900 transmitter, select the pipe material for your application. For convenient reference, some of the available options are shown in Table 3 below.

Table 3: Pipe Materials

Material	Description	Material	Description
Other	Any material	Glass (Pyrex)	Pyrex glass
Steel (Carbon)	Carbon steel	Glass (Flint)	Flint glass
Steel (Stainless)	Stainless steel	Glass (Crown)	Crown glass
Iron (Duct)	Ductile iron	Plastic (Nylon)	Nylon
Iron (Cast)	Cast iron	Plastic (Polye)	Polyethylene
Copper	Copper	Plastic (Polyp)	Polypropylene
Aluminum	Aluminum	Plastic (PVC)	Polyvinyl chloride
Brass	Brass	Plastic (Acryl)	Acrylic plastics
30% Nickel	30% Ni/Cu alloy	Plastic (Glass)	Glass reinforced plastic
10% Nickel	10% Ni/Cu alloy		

Important: The pipe sound speed is automatically entered, based on the selected pipe material. If OTHER is selected for the pipe material, be sure to enter the correct sound speed for your specific pipe material.

4.3.2 Pipe Dimensions

Be sure to enter the following information for your pipe:

- If the **PIPE MATERIAL** is any type of steel and the **PIPE STANDARD** is ANSI, select the **NOMINAL** size and the pipe **SCHEDULE** from the drop down list.

Note: If the **PIPE MATERIAL** is not any type of steel, the above menu options are not available.

- In the **OUTER DIAMETER** box, enter the nominal outside diameter of the pipe.
- In the **WALL THICKNESS** box, enter the wall thickness of the pipe.

4.3.3 Pipe Lining

If you entered **YES** in the **LINING** box, the **LINING MATERIAL**, **LINING SOUND SPEED** and **LINING THICKNESS** must be programmed to ensure accurate flow rate measurements. From the drop-down list of pipe linings supported by the PT900 transmitter, select the pipe lining for your application. For convenient reference, the list of available options is shown in Table 4 below.

Table 4: Available Pipe Linings

Material	Description	Material	Description
Other	Any material	Mortar	Mortar
Tar Epoxy	Tar Epoxy	Rubber	Rubber
Pyrex Glass	Pyrex Glass	Teflon	Teflon
Asbestos Cement	Asbestos Cement		

Important: The lining sound speed is automatically entered, based on the selected lining material. If **OTHER** is selected for the pipe lining, be sure to enter the correct sound speed for your specific pipe lining.

Complete the lining programming by entering your **LINING THICKNESS**.

4.4 Programming the FLUID Menu

The FLUID menu allows the user to specify all the parameters of the fluid flowing through the pipe that are required to ensure accurate ultrasonic flow rate measurements. An example of this menu is shown in Figure 85 below. See the following sub-sections for the options available in programming the various fluid parameters.

Note: The measurement units used for all fluid parameters in these menus depend on the choices made in the UNITS OF MEASUREMENT menu.

PROGRAM
(ONLINE MODE)

COPY CH PRESETS

Channel 1 Off On

PIPE **FLUID** TRANSDU... PLACEMENT

FLUID **SOUND SPEED**
Water/Glycol > 1496.00 m/s

TEMPERATURE **FIXED TEMPERATURE**
Fixed > 25.0 °C

DENSITY **FIXED DENSITY**
Fixed > 1000.0 kg/m³

KINEMATIC VISCOSITY **REFERENCE DENSITY**
0.999999 cST 1000.0 kg/m³

GLYCOL IN WATER
0.0 %

TRACKING WINDOW Off On

MIN SOUND SPEED **MAX SOUND SPEED**
1198.40 m/s 1797.60 m/s

Figure 85: The FLUID Menu

4.4 Programming the FLUID Menu (cont.)

To program the **FLUID** menu, complete the following steps:

1. Select your **FLUID** from the drop-down list (see Table 5 below) and enter the expected **TEMPERATURE** of the fluid during flow rate measurements.
2. If the selected **FLUID** is water or water-based, the **SOUND SPEED** is a constant which is automatically entered in the **SOUND SPEED** box.
3. If you selected **OTHER** as the **FLUID**, the automatic entry in the **SOUND SPEED** box must be changed to the correct value by user.
4. In the **DENSITY** section, open the drop-down list and select Fixed or Active depends on your system. If you choose Fixed, you will need to enter the desired value in the **FIXED DENSITY** section. If you choose Active, you will be able to enter up to 10 Temperature/Density data points for your system in a table on clicking **VIEW/EDIT TABLE** as shown below.

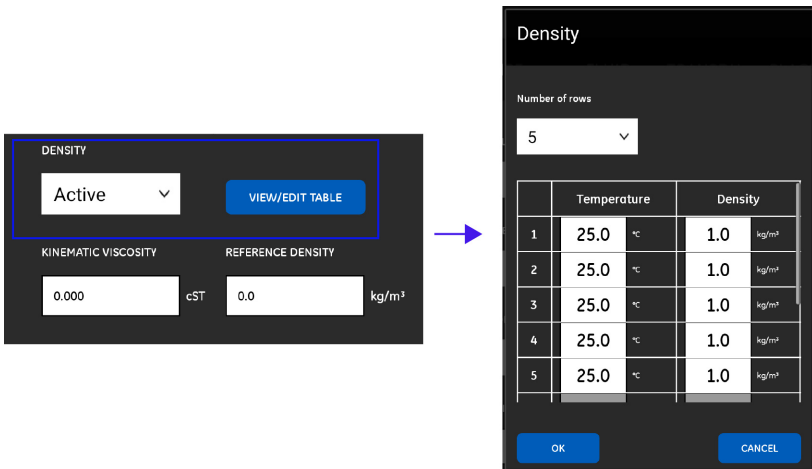

Figure 86: Fluid menu density options

5. The fluid **KINEMATIC VISCOSITY** (see Panametrics document 916-119) is used to calculate the Reynolds Number, which is then used calculate the Reynolds Correction.
6. In the **REFERENCE DENSITY** section, enter the value of reference density which is used to calculate mass for CHI and Ch2.

7. The **TRACKING WINDOW** is used to detect the receive signal when the user is unsure of the fluid sound speed. Set the **TRACKING WINDOW** to either On or Off (the default setting is Off).
8. If the **TRACKING WINDOW** is On, enter the values for the **MAX SOUND SPEED** and the **MIN SOUND SPEED** for the application.

The available FLUID types depends on the current setting for the **TRACKING WINDOW** (see Table 5 below).

Table 5: Available Fluid Types

Tracking Window Off		Tracking Window On
Other	Lube Oil (x200)	Other
Water	Oil	Water
Water/Glycol	Methanol	Water/Glycol
Sea Water	Ethanol	Oil
Oil (22°C)	LN2 (-199°C)	
Crude Oil	Freon (R-12)	

4.5 Programming the TRANSDUCERS Menu

The TRANSDUCERS menu allows the user to specify all the parameters of the transducers that are required to ensure accurate ultrasonic flow rate measurements.

An example of this menu is shown in Figure 87 below. See the following sub-sections for the options available in programming the transducers.

Note: The measurement units used for all transducer parameters in these menus depend on the choices made in the UNITS OF MEASUREMENT menu.

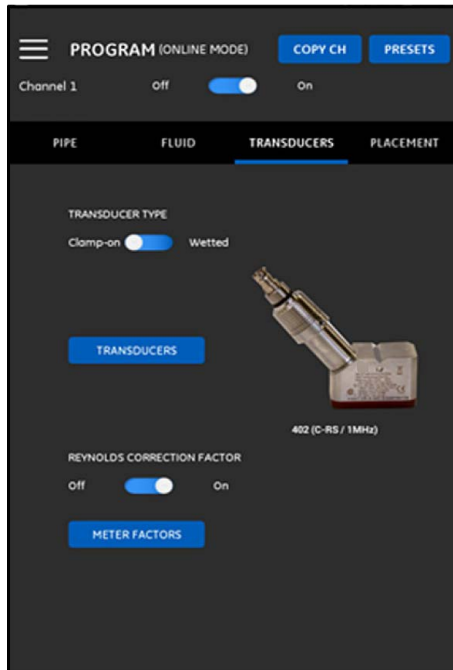

Figure 87: The TRANSDUCERS Menu

4.5.1 Programming the Transducer Parameters

To program your transducer parameters, refer to Figure 87 on page 73 and complete the following steps:

1. On TRANSDUCERS section and select your transducer model from the drop down list.

Note: The Panametrics Transducer Installation Guide for your transducer model provides more detailed information on transducer mounting configurations.

Table 6: Available Clamp-On Transducers

Transducer Number	Transducer Model Name
10	C-PT-N/0.5MHz
11	C-PT-N/2MHz
12	C-PT-H/0.5MHz
13	C-PT-H/1MHz
14	C-PT-M/2MHz
15	C-PT-H/0.5MHz
16	C-PT-H/1MHz
17	C-PT-H/2MHz
23*	CF-LP-H/4MHz
24*	CF-LP-N/4MHz
31	CF-WL/2MHz
401	C-RS/5MHz
402	C-RS/1MHz
403	C-RS/2MHz
407	UTXDR/2MHz
408	UTXDR/4MHz
505*	C-RR/0.5MHz
510*	C-RR/1MHz
520*	C-RR/2MHz
591*	C-RR/0.5MHz
592*	C-RR/1MHz
601	C-AT/0.5MHz
602	C-AT/1MHz
603	C-AT/2MHz
*the most common transducers used with the PT900	

4.5.1 Programming the Transducer Parameters (cont.)

2. If you select standard transducer from the drop down, you will need to enter only the WEDGE TEMPERATURE (see Figure 87). But if you select other as your transducer model, few additional parameters will appear on the screen (see Figure 88) and you must edit this data with the correct specific information.

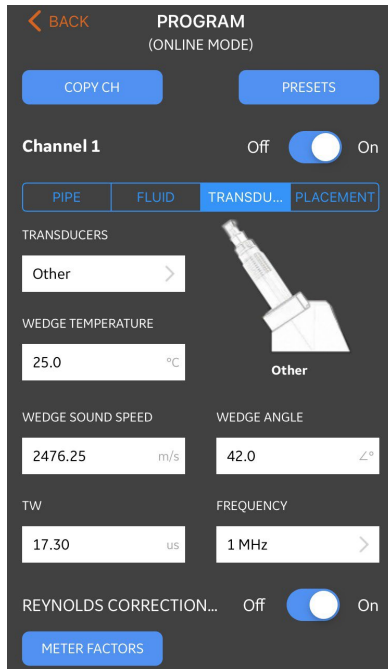

Figure 88: Transducer Menu parameters

- a. **WEDGE TEMPERATURE:** This parameter must be entered manually for all transducers. It should be the average of the ambient temperature and the process temperature.
- b. **WEDGE SOUND SPEED:** This parameter is entered automatically by the PT900 for all Standard transducers, but it must be edited with the correct value provided by Panametrics for Other transducers.

4.5.1 Programming the Transducer Parameters (cont.)

- c. WEDGE ANGLE: This parameter is entered automatically by the PT900 for all Standard transducers, but it must be edited with the correct value provided by Panametrics for Other transducers.
- d. The TW parameter is the time the transducer signal spends traveling through the transducer and the transducer cable. Enter the value provided by Panametrics with your transducer.
- e. Open the FREQUENCY drop-down list and select the frequency at which your transducer is designed to operate.

4.5.2 Setting the Reynolds Correction Factor

The REYNOLDS CORRECTION FACTOR can be set to either On or Off (see Figure 87 on page 73). This factor corrects the fluid velocity measured across a diametrical path so that it more accurately represents the average fluid velocity across the entire cross-sectional area of the pipe. The REYNOLDS CORRECTION FACTOR should be turned On for all clamp-on measurements.

4.5.3 Programming the Meter Factor

To program the METER FACTOR, refer to Figure 87 on page 73 and complete the following steps:

1. Click on the METER FACTOR button to open the menu shown in Figure 89 below.



Figure 89: The Calibrate Factor Menu

4.5.3 Programming the Meter Factor (cont.)

2. The CALIBRATE FACTOR is used to calibrate or adjust the flow rate readings of the PT900 to correspond with another flow rate reference. Use the slide switch to set it to On or Off, as desired.
3. Use the slide switch to set the K-FACTOR to either Single or Table. The, proceed to the appropriate step below:
 - SINGLE: A single multiplier is applied to all PT900 measurements. Generally, if the Reynolds Correction Factor is On, the K-FACTOR should be set to 1.00. Otherwise, the typical range is 0.5 to 2.00.
 - TABLE (CALIBRATE FACTOR = On): A table is displayed (see Figure 90 below) which allows the user to enter multiple K-FACTORS for data points from several different sources or flow variables. These points define a calibration curve for the PT900.

Number of rows

6

	DATA SOURCE	K-FACTOR
1	0.0 m/s	1.0
2	0.0 m/s	1.0
3	0.0 m/s	1.0
4	0.0 m/s	1.0
5	0.0 m/s	1.0
6	0.0 m/s	1.0

OK CANCEL

Figure 90: K-Factor Table

4.6 Programming the PLACEMENT Menu

The PLACEMENT menu allows the user to configure the mounting method of the transducers, based on the programmed information in the TRANSDUCERS menu (see “Programming the TRANSDUCERS Menu” on page 73).

4.6.1 Viewing the Traverse Configuration

For CLAMP-ON transducers, one of the six possible TRAVERSE configurations shown in Figure 91 below is displayed, as appropriate for your programmed transducer information. Typically, a two-traverse installation is used.

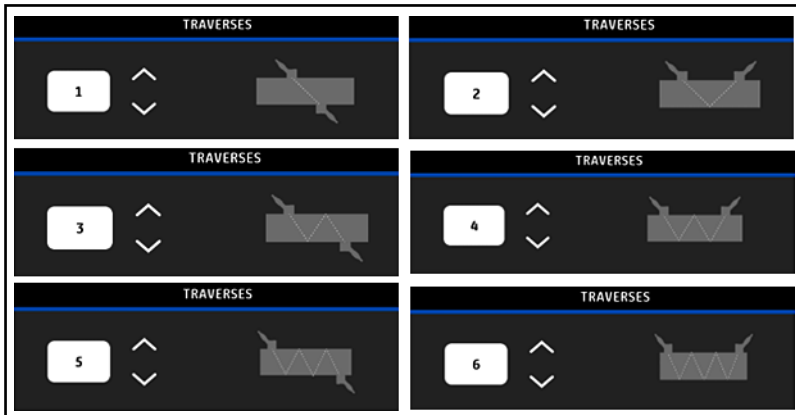

Figure 91: Clamp-On Traverse Configurations

For WETTED transducers, the values for the following parameters are listed, as calculated from your programmed transducer information:

- PATH LENGTH
- AXIAL LENGTH

4.6.2 Viewing the Transducer Spacing

The TRANSDUCER SPACING screen (see Figure 92 below) shows the value calculated by the PT900 for the correct distance between the upstream and downstream transducers, based on your programmed transducer data. This value should be used when installing your transducer clamping fixture on the pipe.

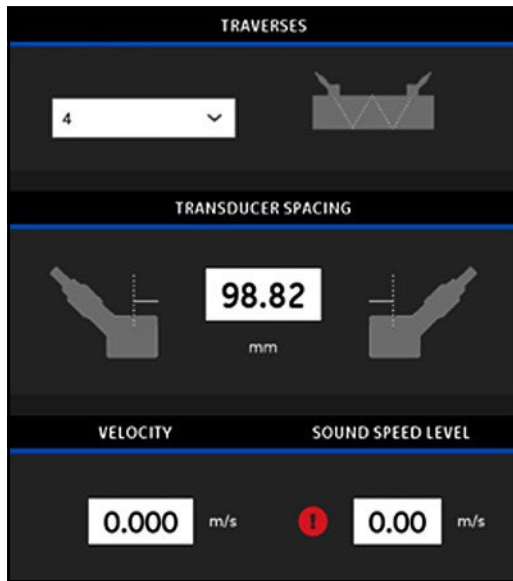

Figure 92: Transducer Spacing Value

4.6.2a Custom Transducer Spacing

If your transducers were installed with a spacing different from the value calculated by the APP, refer to Figure 93 below and input the actual spacing as follows:

Note: Be sure that, if the installed spacing you input is larger than the calculated value, it is not more than 10% above the calculated value.

1. Enter your actual transducer spacing in the units specified by your system UNITS setting.
2. Click the OK button to accept the new value.

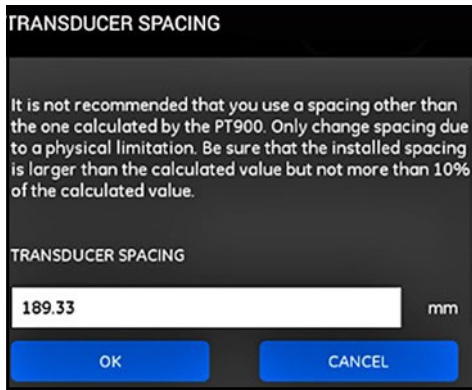

Figure 93: Custom Transducer Spacing

4.6.2b Zero Flow Validation

Important: You must make sure that the fluid in your pipe is not flowing before proceeding.

After the flow in the pipeline is verified to be static, refer to Figure 94 below and calibrate the zero flow setting by completing the following steps:

1. Click the VELOCITY input control.
2. Click the ZERO FLOW button, and then click the OK button.
3. If the displayed velocity value is not zero, record the displayed velocity.
4. Enter the recorded velocity value from the previous step in the MINIMUM FLOW CUTOFF box and click the OK button.

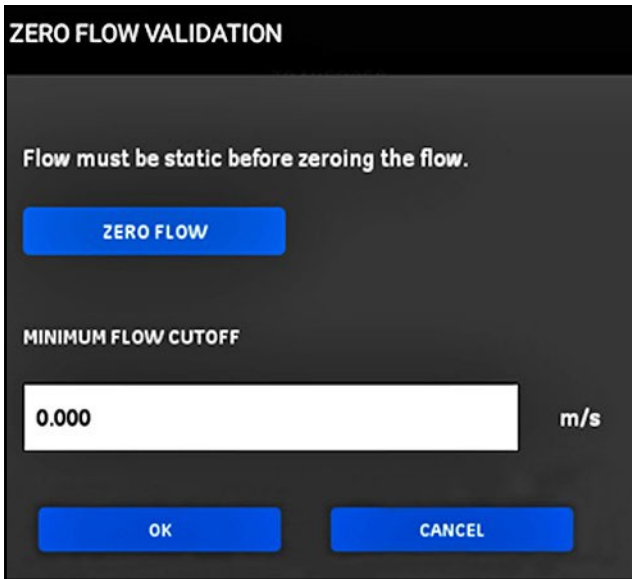

ZERO FLOW VALIDATION

Flow must be static before zeroing the flow.

ZERO FLOW

MINIMUM FLOW CUTOFF

0.000 m/s

OK **CANCEL**

Figure 94: Zero Flow Validation

4.6.2c Sound Speed Validation

When the speed of sound in your fluid does not equal published values, refer to Figure 95 below and set the SOUND SPEED LEVEL by completing the following steps:

1. Click the SOUND SPEED LEVEL input control.
2. Enter your actual sound speed in the units specified by your system UNITS setting.
3. Click the OK button to accept the new value.

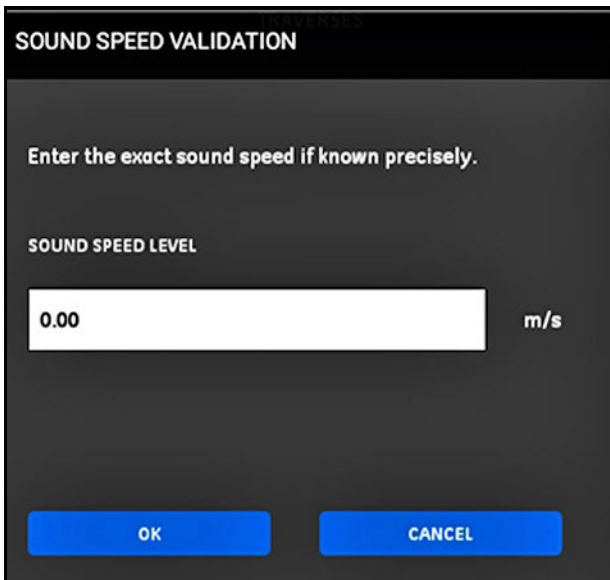

SOUND SPEED VALIDATION

Enter the exact sound speed if known precisely.

SOUND SPEED LEVEL

0.00 m/s

OK CANCEL

Figure 95: Sound Speed Validation

Important: You have now completed the programming of the PIPE, FLUID, TRANSDUCER and PLACEMENT menus. Click on the GO TO MEASURE button to change to the measurement display or click the LOG DATA button to begin logging data.

4.7 Configuring the Program Options

Note: The programming instructions in this section are only required if you will be using any of the options listed below.

From the APP main menu, click the Program Options sub-menu under the PROGRAM menu, as highlighted in Figure 96 below. This will open the Program Options menu shown in Figure 97 on page 84.

The Program Options menu includes the following tabs:

- ENERGY (see page 85)
- INPUTS (see page 87)
- OUTPUTS (see page 88)
- USER FUNCTIONS (see page 93)

Proceed to the appropriate section for programming instructions.

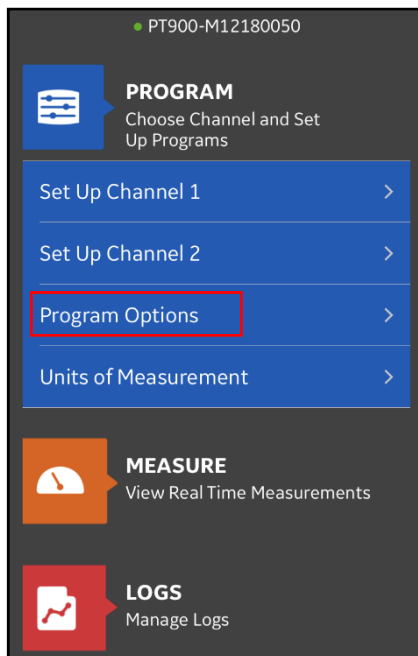

Figure 96: The PROGRAM Menu

4.7 Configuring the Program Options (cont.)

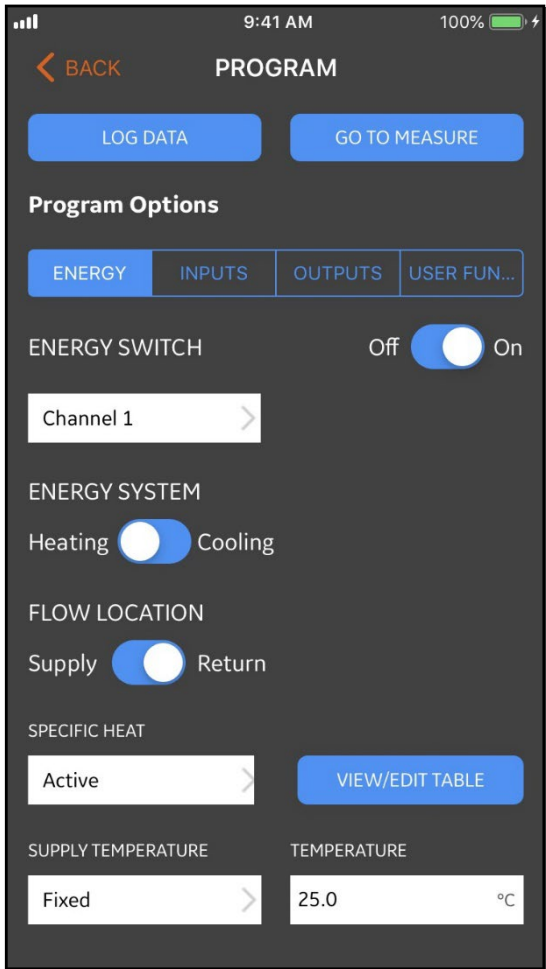

Figure 97: The Program Options Menu

4.7.1 Programming the ENERGY Tab

The first tab in the Program Options menu is ENERGY (see Figure 97 on page 84). The ENERGY tab enables the user to calculate the energy of a system based on the temperature at a supply point, the temperature at a return point and the flow of the fluid through the system. To program the energy tab, complete the following steps:

1. Move the ENERGY SWITCH to either Off or On. If you set it to Off, the ENERGY option is disabled and no additional programming is required in this section. If the ENERGY SWITCH is set to On, proceed to the next step.
2. In the ENERGY CHANNEL section, open the drop-down list and select either CHI or CH2.
3. In the ENERGY SYSTEM section, move the switch to either Heating or Cooling, based on your system type.
4. In the FLOW LOCATION section, move the switch to either Supply or Return, based on your desired flow measurement point. If you choose Supply, RETURN TEMPERATURE section will be displayed and if you choose Return, SUPPLY TEMPERATURE section will be displayed.

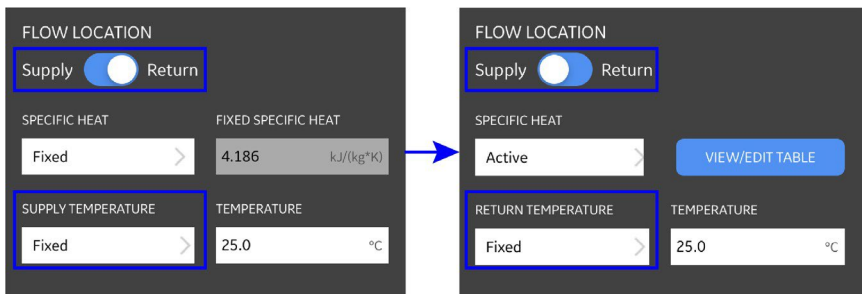

Figure 98: Flow Location selection

5. In the SUPPLY TEMPERATURE section, open the drop-down list and select Fixed or Analog Input 1 or Analog Input 2 as the type of supply for your system. If you choose Fixed, you will need to enter the desired value in the TEMPERATURE section.
6. In the RETURN TEMPERATURE section, open the drop-down list and select Fixed or Analog Input 1 or Analog Input 2 as the type of supply for your system. If you choose Fixed, you will need to enter the desired value in the TEMPERATURE section.

4.7.1 Programming the ENERGY Tab (cont.)

- In the SPECIFIC HEAT section, open the drop-down list and select Fixed or Active as the type of supply for your system. If you choose Fixed, you will need to enter the desired value in the FIXED SPECIFIC HEAT section. If you choose Active, you will be able to enter upto 10 Temperature/SPECIFIC HEAT data points for your system in a table on clicking VIEW/EDIT TABLE as shown below.

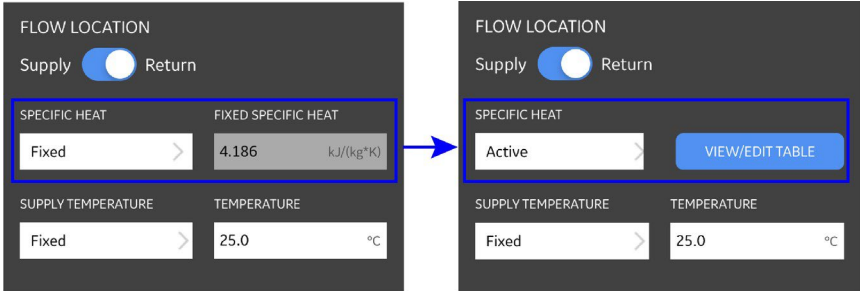

Figure 99: Specific Heat Selection

Cancel VIEW/EDIT TABLE Done

Number of rows
1

TEMPERATURE	SPECIFIC HEAT
25.0 °C	4.186 kJ/(kg*K)
25.0 °C	4.186 kJ/(kg*K)
25.0 °C	4.186 kJ/(kg*K)
25.0 °C	4.186 kJ/(kg*K)
25.0 °C	4.186 kJ/(kg*K)
25.0 °C	4.186 kJ/(kg*K)
25.0 °C	4.186 kJ/(kg*K)

Figure 100: Temperature/Specific heat table

4.7.2 Programming the INPUTS Tab

The INPUTS tab (see Figure 101 below) enables the user to specify the parameters for the energy supply temperature, the energy return temperature and the fixed temperature, based on your previous programming choices in the ENERGY tab.

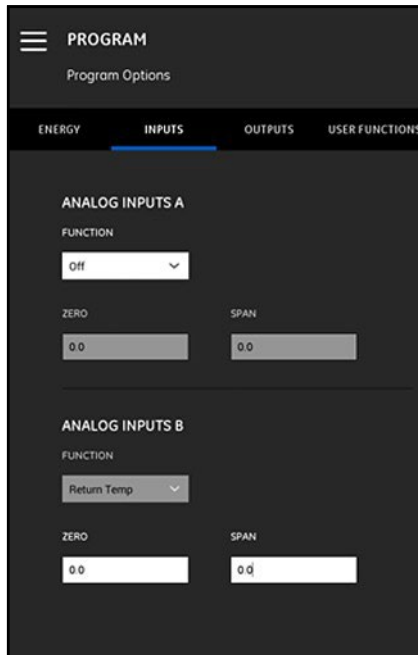

The screenshot shows a mobile application interface for programming a device. At the top, there is a 'PROGRAM' header with a menu icon and 'Program Options' below it. A navigation bar contains four tabs: 'ENERGY', 'INPUTS' (which is highlighted with a blue underline), 'OUTPUTS', and 'USER FUNCTIONS'. Below the navigation bar, there are two sections for configuring analog inputs. The first section is 'ANALOG INPUTS A', which includes a 'FUNCTION' dropdown menu currently set to 'Off', and two input fields for 'ZERO' and 'SPAN', both containing the value '0.0'. The second section is 'ANALOG INPUTS B', which includes a 'FUNCTION' dropdown menu currently set to 'Return Temp', and two input fields for 'ZERO' and 'SPAN', both containing the value '0.0'.

Figure 101: The Inputs Menu

To configure ANALOG INPUTS A, proceed as follows:

1. If either the SUPPLY TEMPERATURE or the RETURN TEMPERATURE has been set to ACTIVE INPUT A in the ENERGY tab, this will be the default value shown in the FUNCTION box. Enter the correct ZERO and SPAN values in the appropriate boxes.
2. If neither the SUPPLY TEMPERATURE nor the RETURN TEMPERATURE has been set to ACTIVE INPUT A in the ENERGY tab, Off is the default value shown in the FUNCTION box. No further action is required, unless the user chooses to change the default entry via the drop-down list. Only then would ZERO and SPAN values be required.

4.7.2 Programming the INPUTS Tab (cont.)

3. If General Purpose is chosen in the FUNCTION box, enter the correct ZERO and SPAN values in the appropriate boxes.

Program ANALOG INPUTS B using the same steps described for ANALOG INPUTS A.

4.7.3 Programming the OUTPUTS Tab

The OUTPUTS tab (see Figure 102 below) enables the user to specify the ANALOG OUTPUTS, DIGITAL OUTPUTS and MODBUS parameters.

The screenshot shows a dark-themed interface for programming a device. At the top, there is a hamburger menu icon and the word "PROGRAM". Below it, "Program Options" is displayed. A horizontal navigation bar contains four tabs: "ENERGY", "INPUTS", "OUTPUTS" (which is highlighted with a blue underline), and "USER FUNCTIONS".

The "OUTPUTS" tab is divided into three main sections:

- ANALOG OUTPUTS:** This section includes a "MEASUREMENT" dropdown menu set to "CH1", a "DATA SOURCE" dropdown menu set to "Amp Disc Up", a "ZERO" input field containing "0.0", a "SPAN" input field containing "0.0", and an "ERROR HANDLING" dropdown menu set to "Low".
- DIGITAL OUTPUTS:** This section includes a "FUNCTION" dropdown menu set to "Pulse", a "MEASUREMENT" dropdown menu set to "AVE", a "DATA SOURCE" dropdown menu set to "Inv Net Tot", a "PULSE VALUE" input field containing "0.0", a "PULSE WIDTH" input field containing "0" with "ms" to its right, and an "ERROR HANDLING" dropdown menu set to "Hold".
- MODBUS:** This section includes an "ADDRESS" input field containing "0", a "BAUD RATE" dropdown menu set to "9600", a "BITS PARITY" dropdown menu set to "None", and a "STOP BITS" dropdown menu set to "1 Bit".

Figure 102: The Outputs Menu

4.7.3 a Analog Outputs

To program the ANALOG OUTPUTS, complete the following steps:

1. Open the drop-down list in the MEASUREMENT box, and select either CHI (Channel 1), CH2 (Channel 2), Average (Average of CHI and CH2) or General (General Function List) for the output.
2. Open the drop-down list in the DATA SOURCE box, and select one of the available data source options from Table 7 below.

Table 7: Available Output Data Sources

Standard Variables		
Channel 1 & Channel 2	AVE (Average)	GEN (General)
Velocity	Velocity	AI 1 Current
Volumetric	Volumetric	AI 2 Current
Standard Volumetric	Standard Volumetric	AI 1 Value
Mass	Mass	AI 2 Value
Batch Forward Totalizer	Batch Forward Totalizer	Power
Batch Reverse Totalizer	Batch Reverse Totalizer	Forward Energy
Batch Net Totalizer	Batch Net Totalizer	Reverse Energy
Batch Totalizer Time	Batch Totalizer Time	User Func 1
Inventory Forward Totalizer	Inventory Forward Totalizer	User Func 2
Inventory Reverse Totalizer	Inventory Reverse Totalizer	User Func 3
Inventory Net Totalizer	Inventory Net Totalizer	User Func 4
Inventory Totalizer Time	Inventory Totalizer Time	User Func 5
Diagnostic Variables		
CHI (Channel 1) & CH2 (Channel 2) Only		
Sound Speed	Angle in Fluid	Peak Percent Down
Reynolds K-Factor	Gain Up	Signal Dynamic
Multi K-Factor	Gain Down	Signal Noise Ratio Up
Delta T	Partial Compression Up	Signal Noise Ratio Down
Active Time Up	Partial Compression Down	Signal Quality Up
Active Time Down	Peak Up	Signal Quality Down
Amplitude Discreet Up	Peak Down	Transit Time Up
Amplitude Discreet Down	Peak Percent Up	Transit Time Down

4.7.3a Analog Outputs (cont.)

3. In the ZERO box, enter the value which corresponds to a 4 mA output.
4. In the SPAN box, enter the value which corresponds to a 20 mA output.
5. Open the drop-down list in the ERROR HANDLING box, and select how the PT900 should handle an analog output fault condition. The options are:
 - Low (force the output to 3.6 mA)
 - High (force the output to 21 mA)
 - Hold (hold the current output value)
 - Other (force the output to a user-supplied value)

4.7.3b Digital Outputs

To program the DIGITAL OUTPUTS, complete the following steps:

1. Open the drop-down list in the FUNCTION box, and select either Off, Pulse, Frequency, Alarm or Gate for the type of digital output desired.
 - a. If Off was selected in the FUNCTION box, no additional programming is required for the DIGITAL OUTPUTS.
 - b. If Pulse was selected in the FUNCTION box, the meter outputs a square wave pulse for each unit of flow passing through the pipeline.
 - Open the drop-down list in the MEASUREMENT box, and select either CH1 (Channel 1), CH2 (Channel 2), Average (Average of CH1 and CH2) or General (General Function List) for the output.
 - Open the drop-down list in the DATA SOURCE box, and select one of the following data source options: Batch Forward Totalizer, Batch Reverse Totalizer, Batch Net Totalizer, Inventory Forward Totalizer, Inventory Reverse Totalizer or Inventory Net Totalizer.
 - Enter the PULSE VALUE and PULSE WIDTH values in the appropriate boxes. These values vary depending on the DATA SOURCE selection.
 - Open the drop-down list in the ERROR HANDLING box, and select either Hold (hold the current value) or Stop (stop the output).

4.7.3 b Digital Outputs (cont.)

- c. If Frequency was selected in the FUNCTION box:
- Open the drop-down list in the MEASUREMENT box, and select either CH1 (Channel 1), CH2 (Channel 2), Average (Average of CH1 and CH2) or General (General Function List) for the output.
 - Open the drop-down list in the DATA SOURCE box, and select the desired data source (see Table 7 on page 89).
 - In the BASE VALUE and FULL VALUE boxes, enter the minimum and maximum values for the selected data source.
 - In the FULL FREQUENCY box, enter the data value which corresponds to the FULL VALUE frequency.
 - Open the drop-down list in the ERROR HANDLING box, and select either Low (force the output to 0 kHz), High (force the output to 10 kHz), Hold (hold the last good value) or Other (force the output to a user-defined value).
- d. If Alarm was selected in the FUNCTION box:
- Open the drop-down list in the MEASUREMENT box, and select either CH1 (Channel 1), CH2 (Channel 2), Average (Average of CH1 and CH2) or General (General Function List) for the output.
 - Open the drop-down list in the DATA SOURCE box, and select the desired data source (see Table 7 on page 89).
 - Open the drop-down list in the ALARM STATE box, and select either Normal (normally-open contacts) or Fail-Safe (normally-closed contacts).
 - Open the drop-down list in the ALARM TYPE box, and select either Low (alarm activates if a measurement is less than or equal to the programmed ALARM VALUE), High (alarm activates if a measurement is greater than or equal to the programmed ALARM VALUE) or Fault (alarm activates on system fault condition).
 - In the ALARM VALUE box, enter the desired alarm trip point.

4.7.3b Digital Outputs (cont.)

- e. If Gate was selected in the FUNCTION box, no additional programming is required.

Note: Gate is used to synchronize the totalizer with the meter calibration system. The gate stops and starts the meter totalizer, so that the user can compare the totalizer value with the measured volume of water in a tank.

4.7.3c Modbus Outputs

The PT900 transmitter supports Modbus digital communication. To program the MODBUS OUTPUT, enter values for the following parameters in the appropriate boxes:

- ADDRESS (Default value is 1)
- BAUD RATE (Default value is 115200)
- BITS PARITY (Default value is 8 None)
- STOP BITS (Default value is 1 Bit)

4.7.4 Programming the USER FUNCTIONS Tab

The USER FUNCTIONS tab (see Figure 103 below) enables the user to program mathematical equations which perform custom calculations on meter measurements. For example, any standard meter parameter can be used to calculate a new custom parameter.

PROGRAM
Program Options

ENERGY INPUTS OUTPUTS **USER FUNCTIONS**

SET USER FUNCTION

FUNCTION: User Func 1 LABEL: label1

UNITS SYMBOL: sym1 DECIMAL: 1

$CH1_AMPup+tbl1|CH1_AMPup|$

OPERATOR:)

4 5 6 7 8 9
0 . 1 2 3
SELECT DELETE SAVE

USER TABLES

TABLE: Table 1 LABEL: table1

EDIT TABLE SAVE TABLE

LOG DATA GO TO MEASURE

Figure 103: The User Functions Menu

4.7.4 Programming the USER FUNCTIONS Tab (cont.)

To program the USER FUNCTIONS, complete the following steps:

1. Open the drop-down list in the FUNCTION box, and select the desired function number (User Func 1 through User Func 5).
2. In the LABEL box, enter a name for the function. A good choice would be the measurement type (e.g., velocity, temperature, etc.).
3. In the UNITS SYMBOL box, enter the units of measure for the function (e.g., feet/sec, degrees F, etc.).
4. Open the drop-down list in the DECIMAL box, and select the desired number of decimal places for the function value (0 to 4).
5. Define the User Function by completing the following steps:
 - a. Open the drop-down list in the OPERATOR box, and select the desired mathematical operator (see Table 8 below for the available options). These operators are used as building blocks to create your function.

Table 8: Available Mathematical Operators

+	-	*	/	^
()	E	MODE	exp
abs	inv	ln	log	sqrt
sin	cos	tan	asin	acos
atan	tbl1	tbl2	tbl3	tbl4

- b. Click the desired mathematical operator in the list.
- c. If your selection is a mathematical function, click the MODE operator in the table, and enter your desired data source and channel. Then, click the SELECT button to confirm your selections or click the DELETE button to cancel them.
- d. After you have completed defining your function from the available operators, click the SAVE button to save the user function to the PT900 memory.

4.7.4 Programming the USER FUNCTIONS Tab (cont.)

6. Define a User Table by completing the following steps:
 - a. Open the drop-down list in the TABLE box, and select a table number (Table 1 through Table 4).
 - b. In the LABEL box, enter a name for the table.
 - c. Click the EDIT TABLE button to open a blank table, as shown in Table 9 below. Then, enter your data in the table.

Table 9: User Table

USER TABLES		
Number of rows	X	Y
1		
2		
3		
4		
5		
6		
7		
8		
9		
10		

OK Cancel

- d. After you have completed the data entry in the table, click the SAVE TABLE button to save the user table to the PT900 memory.

Important: You have now completed the programming of the USER FUNCTIONS menu. Click on the GO TO MEASURE button to change to the measurement display or click the LOG DATA button to begin logging data.

[no content intended for this page]

Chapter 5. Measurements

5.1 Introduction

The PT900 is a transit-time ultrasonic flow meter. During signal processing, many different system parameters are measured or calculated. The PT900 APP provides the user a powerful tool for monitoring these parameters in real-time.

From the initial APP screen, click on the MEASURE  icon to display a screen similar to Figure 104 below. If the system is ONLINE, all of the displayed values are real-time values, but if the system is OFFLINE, the displayed values are the last values obtained when the system was ONLINE.

Note: In iOS application, HELP button is available in the measure screen to access the help screen easily.(marked in red in below image)

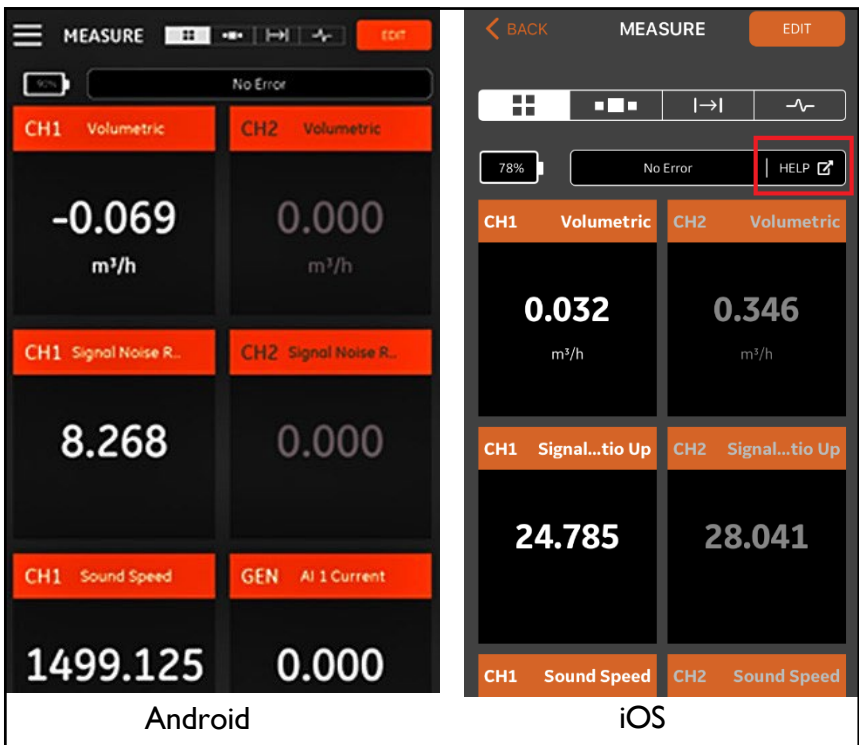

Figure 104: Typical Measurement Screen

5.2 Setting Up the Measurements for Display

The PT900 APP can display up to 10 different variables at the same time. To set up your display screen, click the EDIT button at the top right of the measurement screen to open the SET UP MEASUREMENTS menu, as shown in Figure 105 below.

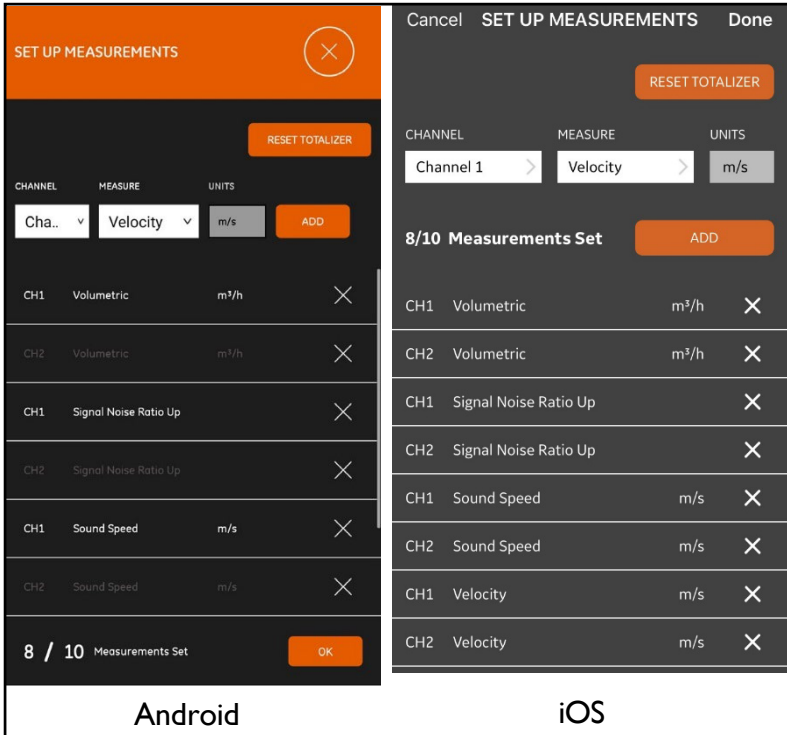

Figure 105: Set Up Measurements Menu

To set up your display measurements, complete the following steps:

1. Open the drop-down list in the CHANNEL box and select either CH1, CH2, Average or General as the channel to be displayed.
2. Open the drop-down list in the MEASURE box and select the desired measurement variable from the list (see Table 10 on page 99 for the options).

5.2 Setting Up the Measurement Screen (cont.)

Table 10: Available Measurement Variables

Standard Variables		
Channel 1 & Channel 2	AVE (Average)	GEN (General)
Velocity	Velocity	AI 1 Current
Volumetric	Volumetric	AI 2 Current
Standard Volumetric	Standard Volumetric	AI 1 Value
Mass	Mass	AI 2 Value
Batch Forward Totalizer	Batch Forward Totalizer	Power
Batch Reverse Totalizer	Batch Reverse Totalizer	Forward Energy
Batch Net Totalizer	Batch Net Totalizer	Reverse Energy
Batch Totalizer Time	Batch Totalizer Time	User Func 1
Inventory Forward Totalizer	Inventory Forward Totalizer	User Func 2
Inventory Reverse Totalizer	Inventory Reverse Totalizer	User Func 3
Inventory Net Totalizer	Inventory Net Totalizer	User Func 4
Inventory Totalizer Time	Inventory Totalizer Time	User Func 5
Diagnostic Variables		
CH1 (Channel 1) & CH2 (Channel 2) Only		
Sound Speed	Angle in Fluid	Peak Percent Down
Reynolds K-Factor	Gain Up	Signal Dynamic
Multi K-Factor	Gain Down	Signal Noise Ratio Up
Delta T	Partial Compression Up	Signal Noise Ratio Down
Active Time Up	Partial Compression Down	Signal Quality Up
Active Time Down	Peak Up	Signal Quality Down
Amplitude Discreet Up	Peak Down	Transit Time Up
Amplitude Discreet Down	Peak Percent Up	Transit Time Down

- Note that the UNITS box is grayed out, as the units are determined by your choices in the Units Options menu (see “Configuring the Units of Measurement” on page 63).
- Click the ADD button to add your new measurement to the real-time measurement set.

5.2 Setting Up the Measurement Screen (cont.)

5. To delete a measurement from the measurement set, click the  button to the right of the desired measurement.
6. Note that the number of measurements currently in the list and the maximum allowed number of measurements (10) are displayed. If you already have 10 measurements listed, you must delete a measurement from the list before you can add a new measurement.
7. At any time, you may reset the batch totalizer to zero by clicking the RESET TOTALIZER button.
8. Click the OK button or Done button(iOS) to close the set up menu and return to the measurement display screen.

5.3 Viewing Measurements

In Figure 106 below, note that CH1 has been turned On and CH2 has been turned Off in the PROGRAM menu. Also, no AI source is connected to the General channel, because the value is zero.

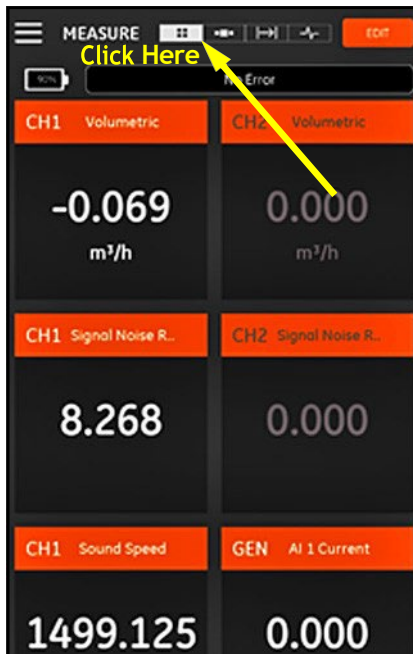

Figure 106: Multiple Measurement Screen

5.3 Viewing Measurements (cont.)

Clicking any measurement on the measurement screen will open a popup dialog box for changing the decimal format for that measurement (see Figure 107 below).

1. Select the desired decimal format from the drop-down list.
2. Select the desired number of decimal places from the drop-down list.
3. Click OK to confirm the selections, or click CANCEL to discard the changes.

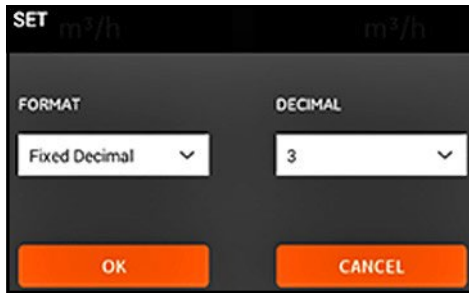



Figure 107: Setting the Decimal Format

5.3.1 Displaying Multiple Measurements

The default measurement screen is a multi-measurement format, which means that all measurements which have been set up are displayed on one page with scrolling

capability. An indication of this display type is the highlighted  icon at the top of the screen (see Figure 106 on page 100). Note the following:

- You may click the EDIT button at the top right of the screen at any time to open the SET UP MEASUREMENTS menu.
- An Error Status box is located just above the measurement display section of the screen. If there are no system errors, No Error is displayed (see Figure 106 on page 100). However, if a system error does occur, the error information is displayed in this location with a flashing red background.

5.3.2 Displaying a Single Measurement

To change the screen to a one-measurement display (see Figure 108 below), click the  icon. In this mode, one measurement is displayed at a time and you can switch between available measurements by swiping across the screen left or right.



Figure 108: Single Measurement Screen

5.3.2 Displaying a Single Measurement (cont.)

Note the following:

- The default one-measurement display is the numeric value of the real-time measurement, as shown in Figure 108 on page 102.
- To switch the display to GRAPH mode, click the  icon at the top right of the screen. As shown in Figure 109 below, the values of the measurement as a function of time are displayed as a graph.



Figure 109: Graph Measurement Screen

- To switch the display back to NUMERIC mode, click the  icon at the top right of the screen.

5.3.2 Displaying a Single Measurement (cont.)

- When in GRAPH mode, click the SETTING button just above the graph to open the SET Y AXIS menu shown in Figure 110 below.



Figure 110: Graph Parameters Menu

To edit the parameters for the Y axis, complete the following steps:

1. Move the slide switch to Manual.
2. The Min Y and Max Y text boxes are now active. You may now enter your desired values in these text boxes.
3. After editing the values, click the OK button and the new values will take effect, or click the CANCEL button to keep the old values.

5.3.3 Displaying the Totalizer Screen

The Batch Totalizer is used for measuring the total volume of fluid which passes the measurement point over a period of time. This can be done automatically by using the external Digital Output Gate (see “Digital Outputs” on page 90) or it can be done manually.

For manual operation, refer to Figure III below and proceed as follows:

1. From the measurement screen, click on the  icon at the top of the screen.
2. To start the batch totalizer, click the START button. Note that while the totalizer is running, the START button is replaced by a STOP button.
3. To stop the batch totalizer, click the STOP button. Note that when the totalizer is not running, the STOP button is replaced by a START button.
4. At any time, you may reset the batch totalizer to zero by clicking the RESET button. Note that this resets only the batch totalizer.

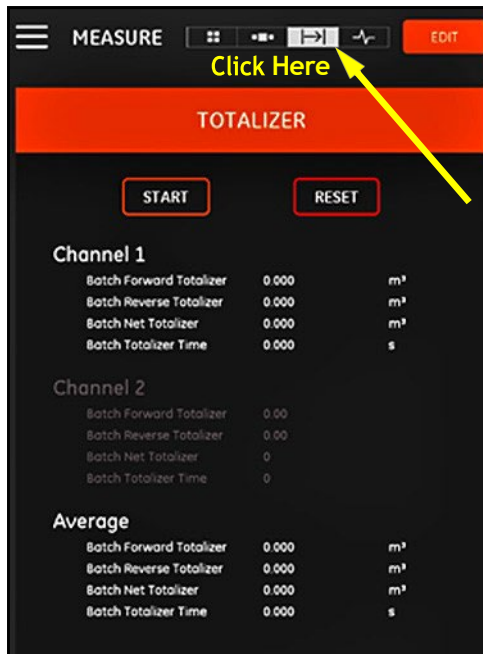

Figure III: Totalizer Screen

5.3.4 Displaying the Diagnostics Parameters

During operation, the PT900 measures various system parameters for the purpose of analyzing the system performance. These system diagnostic parameters are listed in the DIAGNOSTICS measurement screen (see Figure 112 below). To access

this screen, click the  icon at the top of the measurement screen.

After you have finished viewing the diagnostic parameters, click the appropriate icon at the top of the screen to return to the measurement display.

Note: In the screen below, Channel 1 is active and Channel 2 is inactive. Also, all the signal diagnostic parameters are within their normal range, as indicated by the green check marks to the right of each parameter.

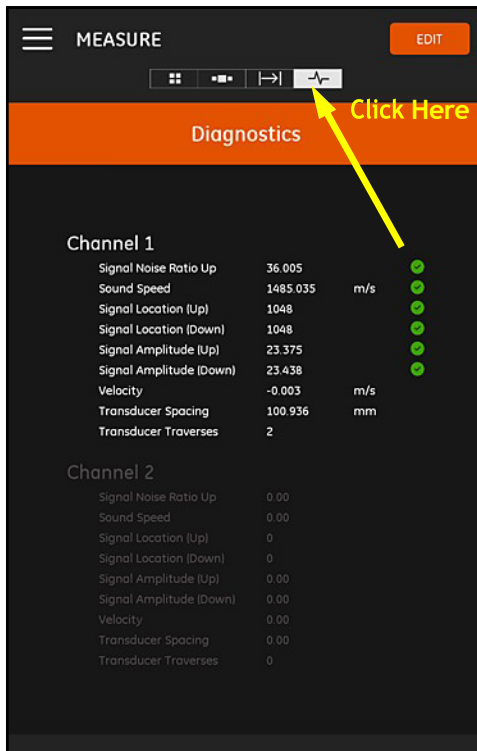

Figure 112: Diagnostics Measurement Screen

Chapter 6. Logging Data

6.1 Introduction

The PT900 transmitter supports an easy-to-use data logging function, which allows diagnostic and measurement data to be recorded in a log file. To create a log file, the following parameters must be specified:

- The following Channels are available for logging:
 - CHANNEL 1 (34 available variables)
 - CHANNEL 2 (34 available variables)
 - Average CHANNEL (12 available variables)
 - General CHANNEL (10 available variables)
- See Table 10 on page 99 for a complete list of the measurement variables available for each of the above channels.
- The start time and date, end time and date, and the time interval must be specified for the log.
- The logged data file is recorded in .CSV format. The log files can be accessed via the PT900 USB port, and they can be opened with most common text editors.
- The time interval, the length of the logging run and the number of logs all affect the total amount of memory required to store all of your log files. The total memory usage and the remaining unused memory can be viewed in the TRANSMITTER STORAGE menu.

6.2 Adding a Log

The LOG function can be accessed from the APP main menu. When you enter the LOG function for the first time, you will see the message shown in Figure 113 below.

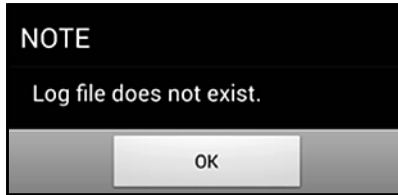

Figure 113: Initial Log Screen

Important: Before creating a new log, be sure to synchronize the transmitter and the tablet time settings by clicking the DATE & TIME button in the TRANSMITTER menu (see Figure 118 on page 116).

Just click the OK button to open the ADD LOG menu shown in Figure 114 below.

A screenshot of the "ADD LOG" menu. The title bar is red with "ADD LOG" in white and a close button (X) on the right. The main area is black with white text and input fields. Fields include: LOG NAME (text input with "12345abcdef"), FORMAT (radio buttons for "Linear" and "Circular", with "Circular" selected), CHANNEL (dropdown menu with "CH1"), INTERVAL (dropdown menu with "1" and a "s" unit), START DATE & TIME (text input with "06-15-2016 11:16"), and END DATE & TIME (text input with "06-15-2016 11:18"). A red "SAVE" button is at the bottom right.

Figure 114: ADD LOG Menu

6.2 Adding a Log (cont.)

Program the new log parameters as shown in Table 11 below:

Table 11: Programming the Log Parameters

Parameter	Entry Type	Description
LOG NAME:	Manual entry	11 characters maximum
FORMAT:	Slide switch	Linear: Record all values from start time to end time Circular: After 100 values are recorded, the oldest value is deleted before a new value can be added.
CHANNEL:	Drop-down list	CH1, CH2, Average, General (see Table 10 on page 99 for the available measurement variables).
INTERVAL:	Drop-down list	1–20 sec (the time between each pair of consecutive values).
START DATE & TIME:	Manual entry	When the log starts
END DATE & TIME:	Manual entry	When the log stops

Note the following:

- The PT900 transmitter will only start the log if the programmed START DATE & TIME arrives and the transmitter is powered On at that time.
- The programmed END DATE & TIME must occur after the programmed START DATE & TIME, or an error message is displayed.
- There is no defined limit for either the total number of logs or for the size of an individual log stored in the transmitter, but the total available amount of log storage memory is limited to the PT900 storage capacity.

6.3 Deleting, Stopping or Editing a Log

In the LOGS main menu (see Figure 115 below), all existing logs and their current status are listed. Each listed log may be edited, stopped or deleted, depending on their current status.

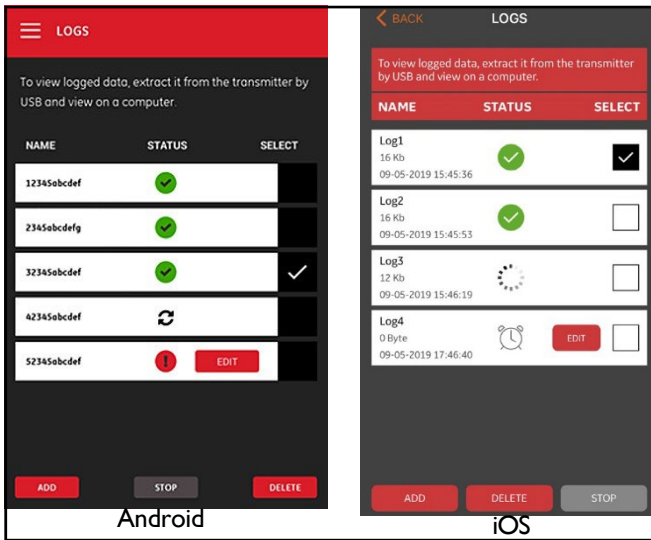







Figure 115: LOGS Main Menu

Each listed log has one of the following three status designations:

Table 12: Log Status

Status	Android Icon	iOS Icon	Explanation
Pending			This icon means the log is Pending, because the start time has not yet arrived. In this status, you can EDIT, DELETE but cannot STOP the log. STOP icon will be disabled in iOS for pending logs.
Stopped			This icon means the log is Stopped, because the end time has passed or the user has stopped it. In this status, you can only DELETE the log.
Running			This icon means the log is Running, because the end time has not yet arrived. In this status, you can only STOP the log prior to the end time.

6.3.1 Deleting a Log

To DELETE a Pending or Stopped log, complete the following steps:

1. On the LOGS main menu (see Figure 115 on page 110), click in the SELECT column to the right of the log you wish to delete.
2. Verify that the  icon is shown to the right of the log you wish to delete.
3. Click the DELETE button to delete the selected log.

6.3.1 a Stopping a Log

To STOP a Pending or Running log, complete the following steps:

1. On the LOGS main menu (see Figure 115 on page 110), click in the SELECT column to the right of the log you wish to stop.
2. Verify that the  icon is shown to the right of the log you wish to stop.
3. Click the STOP button to stop the selected log.

6.3.2 Editing a Log

To EDIT a Pending log, complete the following steps:

1. On the LOGS main menu (see Figure 115 on page 110), click in the SELECT column to the right of the log you wish to edit.
2. Verify that the  icon is shown to the right of the log you wish to stop.
3. Click the EDIT button to open the EDIT LOG menu shown in Figure 116 below.

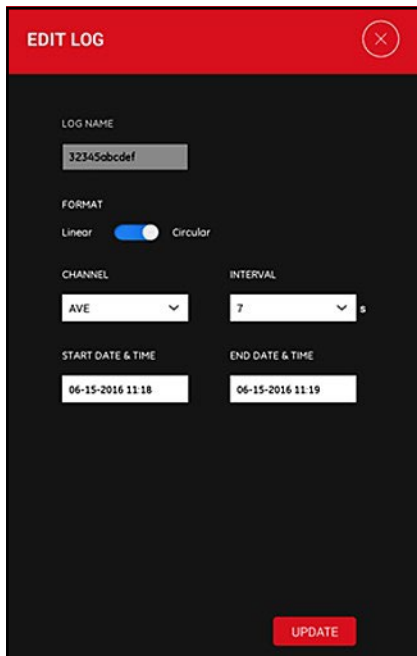

The screenshot shows a mobile application interface for editing a log. At the top, there is a red header bar with the text "EDIT LOG" and a circular close button with an "X" icon. Below the header, the form is set against a dark background with white text and input fields. The fields are: "LOG NAME" with a text box containing "32345abcdef"; "FORMAT" with a toggle switch currently set to "Linear" (blue) and "Circular" (grey); "CHANNEL" with a dropdown menu showing "AVE"; "INTERVAL" with a dropdown menu showing "7" and a small "s" for seconds; "START DATE & TIME" with a text box showing "06-15-2016 11:18"; and "END DATE & TIME" with a text box showing "06-15-2016 11:19". At the bottom right of the form is a red button with the white text "UPDATE".

Figure 116: The EDIT LOG Menu

4. Edit any of the log parameters in the above menu using the same instructions given in "Adding a Log" on page 108.
5. After your edits are complete, click UPDATE button to save your changes.

6.3.3 Viewing a Log

The logged data is stored in the PT900 transmitter. This data can be accessed from a PC via a USB connection.

To view a log, complete the following steps:

1. Be sure the transmitter and tablet time settings are synchronized by setting the transmitter time in the TRANSMITTER > DATE & TIME menu (see Figure 118 on page 116).
2. Unplug the USB cable and plug it back in after the PT900 transmitter is powered On.
3. Unplug the USB cable and plug it back in after completing a log. You can then access the finished log on the PT900.

[no content intended for this page]

Chapter 7. Configuring the Transmitter

7.1 Introduction

To configure the PT900 transmitter, click the TRANSMITTER icon in the APP main menu (see Figure 117 below).

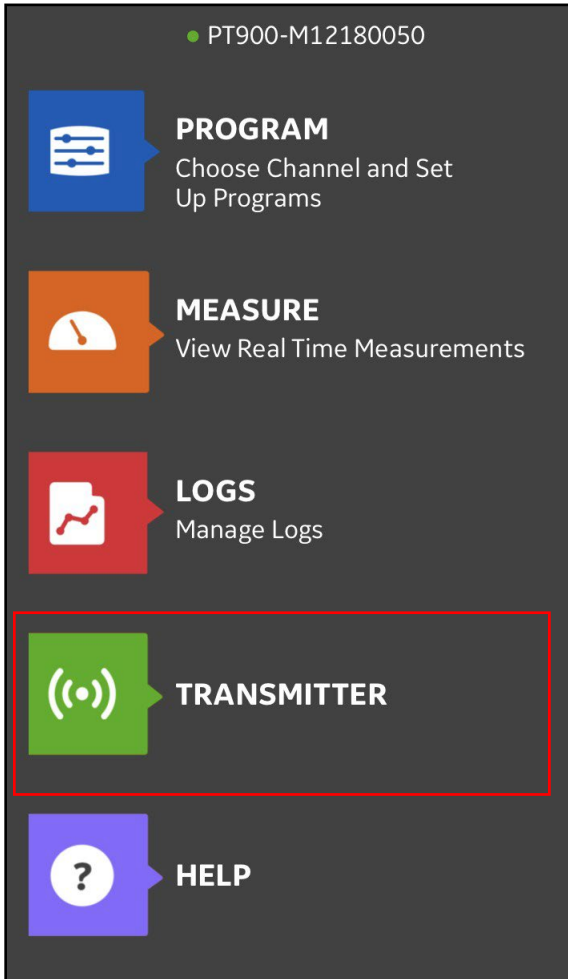

Figure 117: The Transmitter Menu

If a PT900 transmitter is CONNECTED to the tablet APP via Bluetooth, the TRANSMITTER menu shows device information about the PT900 transmitter, the battery and the memory usage. However, if the connection is OFFLINE, this information is unavailable. See examples of both possibilities in Figure 118 below.

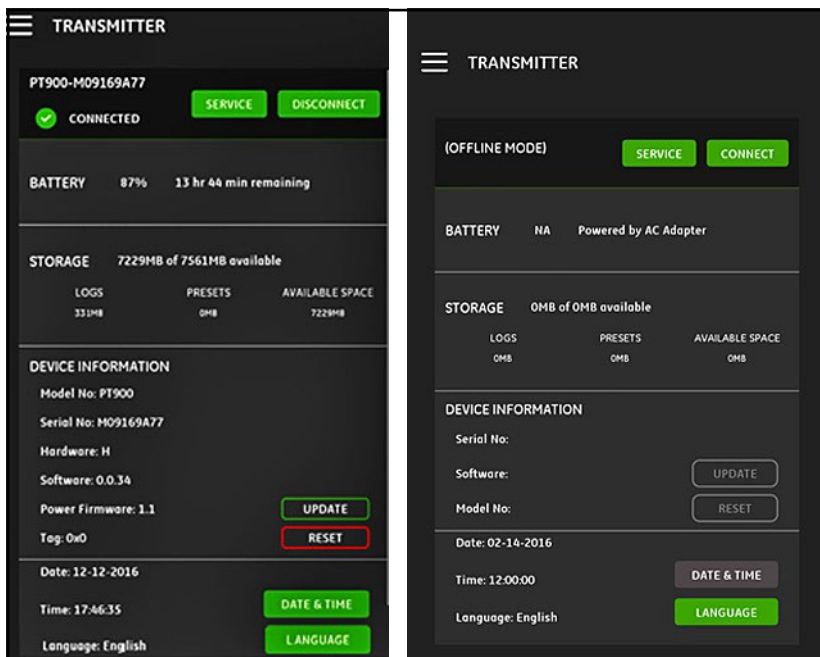

Figure 118: CONNECTED (Left) and OFFLINE (Right) Menus

The above menus include the following items:

- The CONNECT/DISCONNECT button is used to connect a transmitter which is currently OFFLINE or to DISCONNECT a transmitter which is currently ONLINE.
- The SERVICE button is used to configure transmitter functions.

- The BATTERY section shows the remaining battery time for an ONLINE transmitter (not available for an OFFLINE transmitter).
- The STORAGE section shows the current memory usage for Logs and Presets and the remaining unused embedded storage memory for an ONLINE transmitter (not available for an OFFLINE transmitter).
- The DEVICE INFORMATION section shows the Serial Number, Software Version and Model Number for an ONLINE transmitter (not available for an OFFLINE transmitter).

Note: If a firmware update is needed, upload the new firmware file to the transmitter via the USB connection, then click the UPDATE button. The transmitter is unavailable during the update and it will automatically reboot when the update is complete. After the reboot, the transmitter will be OFFLINE.

- The RESET button enables the user to reset the transmitter remotely (not available for an OFFLINE transmitter).

Note: Resetting the transmitter erases all PRESETS and LOGS, but all factory calibrated data is kept. After the reset, the transmitter will be OFFLINE., and a warning message is displayed as a reminder.

- The DATE & TIME button is used to set the transmitter's Real Time Clock (RTC). This date and time are synchronized with tablet settings.
- The LANGUAGE button is used to select the language used by the tablet APP. The languages listed in Table 13 below are supported:

Table 13: Supported APP Languages

• English	• Français	• Castellano
• 中文	• Nederlands	• Português
• Deutsch	•	• Español
• 日本語	• Svenska	• Türkçe
• Italiano	• Русский	• العربية

7.2 Updating the PT900 Transmitter Software

To update the PT900 transmitter software, complete the following steps:

1. Obtain the image file (ipl-ifs-PT900_vx.x.xx_svnxxx.bin) for the new PT900 software version.
2. Rename the new image file as image.bin.
3. Copy the new image.bin file to the PT900 from a PC, using a USB cable as shown in Figure 119 below.

Note: If an old image.bin file is already on the PT900, overwrite it.



Figure 119: USB Cable Connected to the Transmitter

Note: The image.bin file should be copied to the root directory of the PT900, as shown in Figure 120 below.

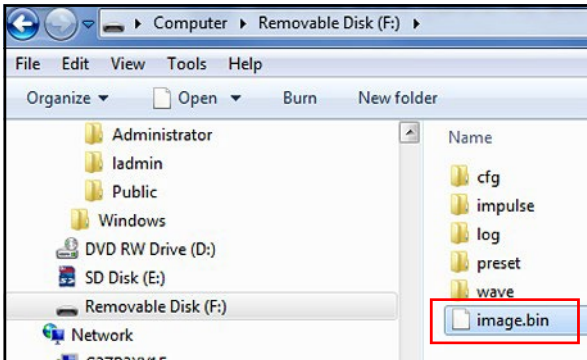

Figure 120: Image.bin File Location on PT900

- In the APP TRANSMITTER menu, click the UPDATE button (see Figure 121 below) to start the update.

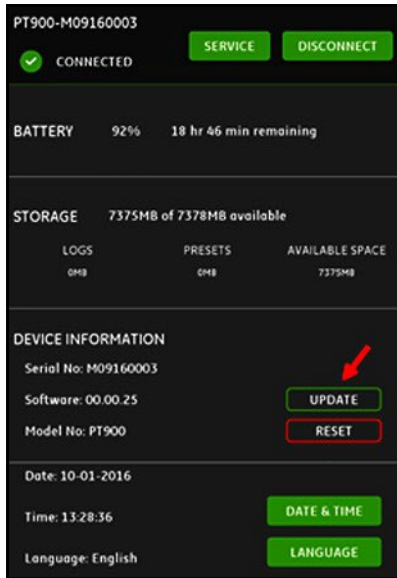

Figure 121: UPDATE Button in TRANSMITTER Menu

The system will check the validation of the new image file by checksum. If the check is OK, the new software will load in the next reboot. If the check is NO, the original software will load in the next reboot.

- At the screen shown in Figure 122 below, click the OK button to confirm the update and continue.

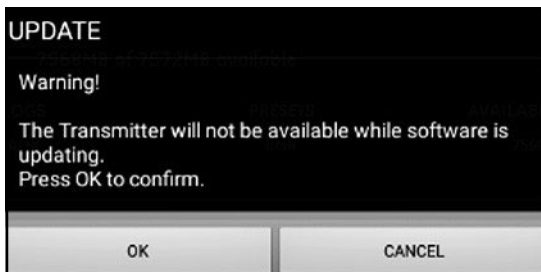

Figure 122: Update Confirmation Screen

The update will take about 30 seconds to complete, and the screen shown in Figure 123 below will be displayed during the update.

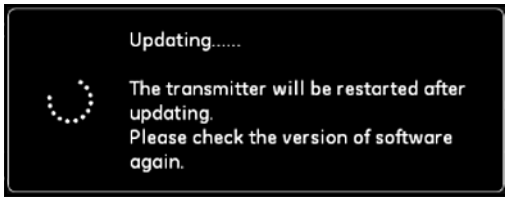

Figure 123: Update in Progress Screen

6. After the transmitter reboots, the message shown in Figure 124 below will pop up. Click the OK button to reconnect the transmitter.



Figure 124: Transmitter Reconnection Screen

7. Go to the TRANSMITTER menu (see Figure 118 on page 116) and verify that the device information is correct.

If you had any problems during the update, make sure that the following conditions were met:

- Make sure that the power is always ON during an update, and check that the battery capacity is > 20% or the AC power adapter is connected.
- Make sure that the transmitter is NOT in configure mode. It must be in either IDLE or normal measurement mode.
- If you want to reinstall your old system Presets, do not delete the preset directory on the PT900.
- If you want the original factory settings, click RESET.
- Sometimes, the new software will include a new version of the factory Presets. If so, the old Presets will automatically be overwritten by new ones during the update.

7.3 Programming the Transmitter SERVICE Menu

The transmitter SERVICE menu includes the following sub-menus:

- CALIBRATION (see page 121)
- METER SETUP (see page 124)
- TESTING (see page 127)
- ERROR LIMITS (see page 130)

7.3.1 Programming the CALIBRATION Menu

The CALIBRATION option (see Figure 125 below) is used to calibrate the transmitter's ANALOG OUTPUT and the ANALOG INPUT.

Important: The CALIBRATION function only works if the transmitter is ONLINE.

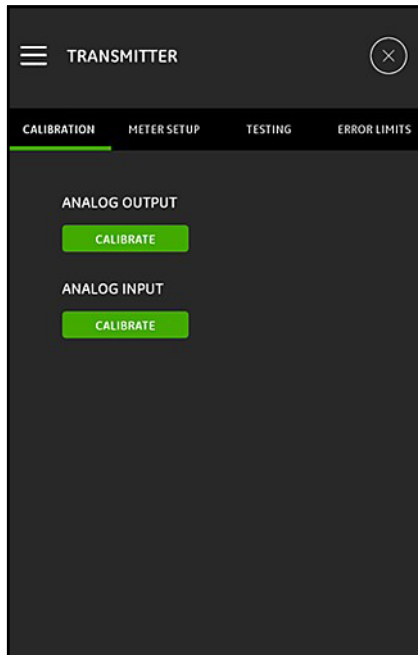

Figure 125: The Calibration Menu

7.3.1 a Calibrating the ANALOG OUTPUT Option

To calibrate the transmitter ANALOG OUTPUT, refer to Figure 126 below and complete the following steps:

1. Click the CALIBRATE button to open the ANALOG OUTPUT CALIBRATION menu.
2. Move the slide switch to the 4 mA position.
3. In the Actual 4 mA text box, enter the output current actually measured with a digital ammeter at the transmitter's analog output.
4. Click the ADJUST button to perform the calibration or click the CANCEL button to discard the new value.
5. Move the slide switch to the 20 mA position.
6. In the Actual 20 mA text box, enter the output current actually measured with a digital ammeter at the transmitter's analog output.
7. Click the ADJUST button to perform the calibration or click the CANCEL button to discard the new value.
8. Click the RESET button to reset both the 4mA and 20mA calibrations.

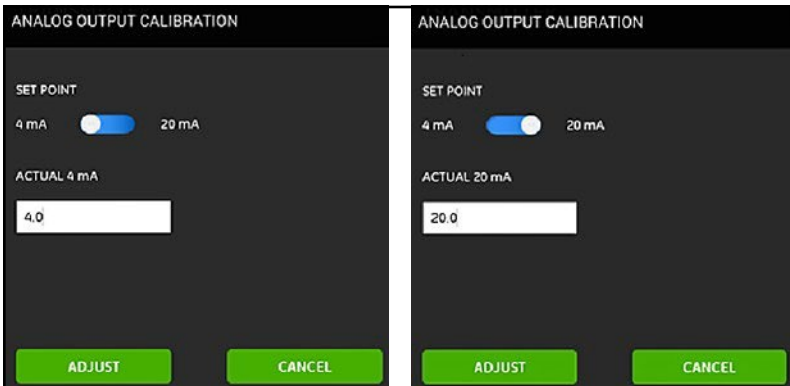

Figure 126: 4 mA (Left) and 20 mA (Right) Calibration Menus



WARNING! Transmitter remains in configure mode when the App is killed from calibration screen

7.3.1 b Calibrating the ANALOG INPUT Option

To calibrate the transmitter ANALOG INPUT, refer to Figure 127 below and complete the following steps:

1. Click the CALIBRATE button to open the ANALOG INPUT CALIBRATION menu.
2. Move the first slide switch to the AI 1 position.
3. Connect a 4 mA calibrated current source to the transmitter's analog input.
4. Move the next slide switch to the 4 mA position.
5. In the 4 mA text box, the input current measured by the PT900 transmitter is displayed (see Before screen below).
6. Click ADJUST to perform the calibration or click CANCEL to discard the displayed value. After clicking the ADJUST button, the current value displayed in the 4 mA text box should be much closer to 4 mA (see After screen below).
7. Repeat steps 2-6 to calibrate the 4 mA and 20 mA inputs for AI 1 and AI 2.
8. Click the RESET button to reset all the analog input calibrations.

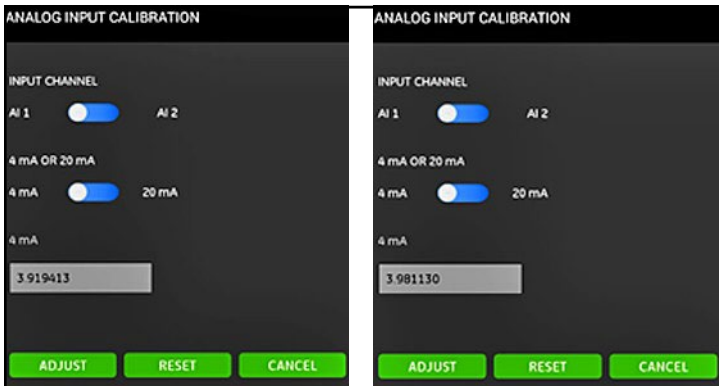

Figure 127: Before (Left) and After (Right) 4 mA Values

7.3.2 Programming the METER SETUP Menu

The METER SETUP option (see Figure 128 below) is used to configure the following PT900 system parameters (see the following section for instructions):

- TOTALIZER
- RESPONSE TIME
- POWER SAVING MODE
- POWER SAVING TIME
- PEAK DETECTION METHOD
- PEAK THRESHOLDS

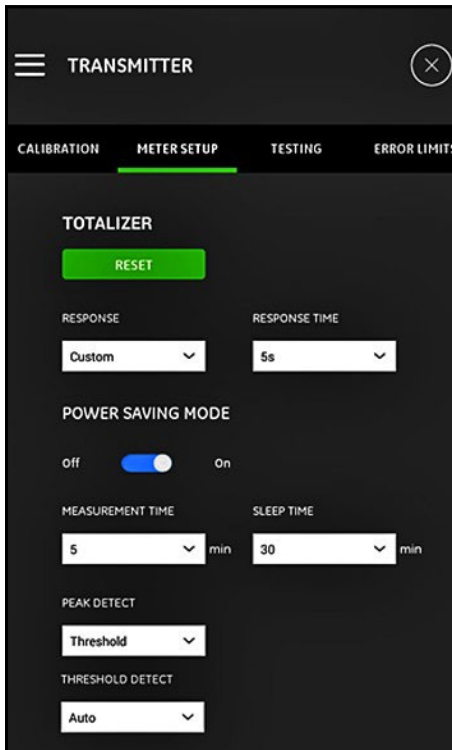

Figure 128: The METER SETUP Menu

7.3.2 a Programming the TOTALIZER Option

The TOTALIZER option enables the user to reset the values of all batch and inventory totalizers (i.e., Forward Totalizer, Reverse Totalizer, Net Totalizer and Totalizer Time) in all channels to zero by clicking the RESET button.

The RESPONSE option enables the user to choose the time interval in seconds between any two measurements:

- If Custom is selected from the drop-down list, the following options are available: 1s, 2s, 5s, 10s, 30s, 60s, 100s, 200s, 300s or 500s.
- If Fast is selected from the drop-down list, the default time interval is used.

7.3.2b Programming the POWER SAVING MODE Option

The POWER SAVING MODE slide switch changes the PT900 transmitter into a power saving measurement mode. After turning the POWER SAVING MODE to On, the following parameters must be set:

- From the MEASUREMENT TIME drop down list, select one of the following options: 5min, 10min, 20min, 30min or 60min.
- From the SLEEP TIME drop down list, select one of the following options: 30min, 60min, 90min, 120min, 150min, 180min, 210min or 240min.

For example, if the MEASUREMENT TIME is 5 min and the SLEEP TIME is 30 min, the PT900 transmitter would take measurements for 5 minutes and then sleep for 30 minutes, before repeating the cycle.

7.3.2c Programming the PEAK DETECT Option

From the drop-down list in the PEAK DETECT option, select the desired method for identifying the peak of the received signal. The following options are available:

- The PEAK method is no longer available.
- With the THRESHOLD method, the peak is identified as the point where the signal crosses a threshold that is a percentage of the maximum signal detected. This method is more reliable in marginal signal conditions.

7.3.2 d Programming the THRESHOLD Option

If the THRESHOLD method is selected in the PEAK DETECT option, the THRESHOLD DETECT parameter must be configured. From the drop-down list, select one of the following options:

- With the Auto method, the threshold is detected automatically.
- With the Manual method, the minimum and maximum threshold percentage (0 to 100%) must be input. The Peak Percentage is also required.

7.3.2 e Saving Your Settings

Important: Be sure to click the SAVE button before leaving the METER SETUP menu, or all of your settings will be discarded.

7.3.3 Programming the TESTING Menu

The TESTING menu (see Figure 129 below) is used to ensure that the PT900 is performing properly. The following tests are included:

- WATCHDOG METER
- WAVE SAMPLE CHANNEL

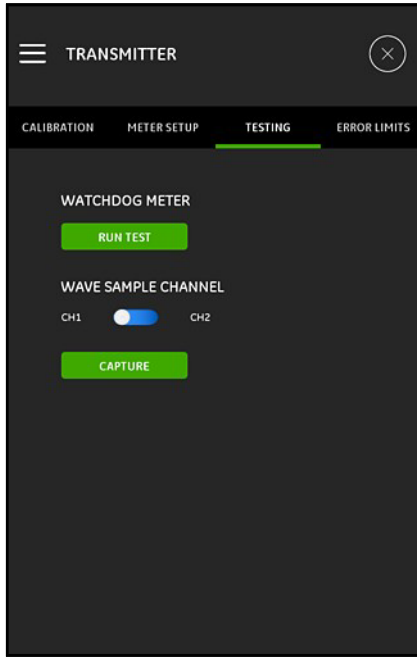

Figure 129: The TESTING Menu

7.3.3 a Running the Watchdog Test

The PT900 transmitter includes a Watchdog Timer Circuit. This circuit automatically resets the transmitter. Proceed as follows:

1. Click the RUN TEST button in the TESTING menu (see Figure 129 on page 127).
2. A properly functioning PT900 restarts if the Watchdog Test is run, and a warning message similar to Figure 130 below is displayed.

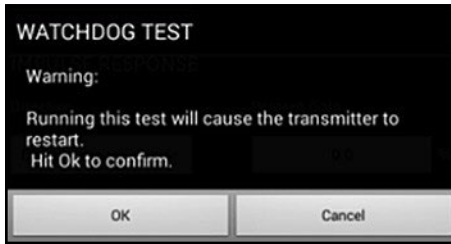

Figure 130: Watchdog Test Warning

3. Click the OK button to proceed with the test or click the Cancel button to abort the test.

Important: The PT900 transmitter is disconnected from the tablet after the reset. You must reconnect them via Bluetooth before further use.

7.3.3 b Testing with the Wave Sample Channel

The WAVE SAMPLE CHANNEL test captures signals and displays them in a graph similar to Figure 131 below. Click the DOWNLOAD button to save the screen capture to the <internal storage of tablet>/TransPort/ScreenShot folder.

Important: Wave samples are only required for troubleshooting with Panametrics's guidance.

Note: "If permission of photos is not available while saving the waveform and the user tries to change it from settings, the App will restart.

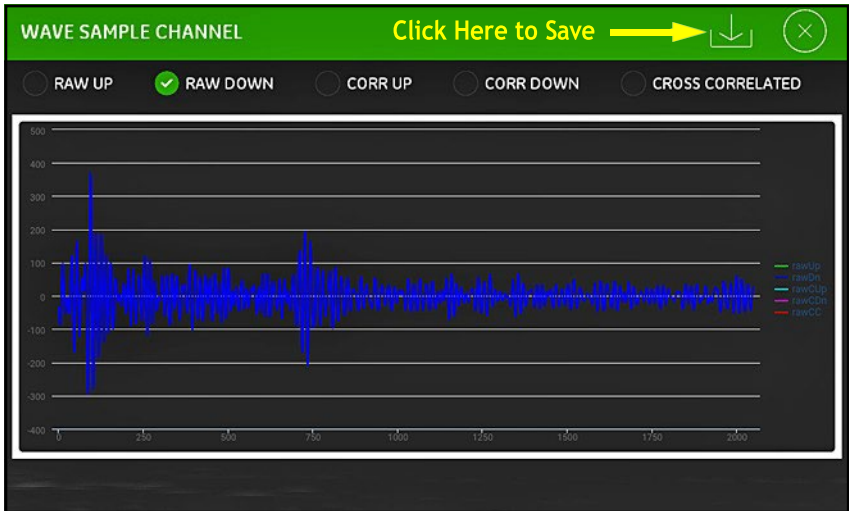

Figure 131: Wave Sample Channel Capture

7.3.4 Programming the ERROR LIMITS Menu

The ERROR LIMITS menu (see Figure 132 below) enables the user to set limits for an incoming signal. When the signal falls outside these programmed limits, an error indication is displayed on the MEASUREMENT screen.

TRANSMITTER

CALIBRATION METER SETUP TESTING **ERROR LIMITS**

VELOCITY

MIN LIMIT MAX LIMIT

-12.0 m/s 12.0 m/s

AMPLITUDE

MIN LIMIT MAX LIMIT

14.0 30.0

SOUND SPEED (+/-)

20.0 %

ACCELERATION

15.0 m/s²

COMPRESSION RATIO

1.05

SOS VARIATION RATE

1.0 m/s

SAVE

Figure 132: The ERROR LIMITS Menu

7.3.4 Programming the ERROR LIMITS Menu (cont.)

To program the ERROR LIMITS menu, complete the following steps:

1. In the VELOCITY section, enter the desired MIN LIMIT and MAX LIMIT values in the appropriate text boxes. If the measured velocity is outside these limits, the E3: VELOCITY RANGE message is displayed on the measurement screen.
2. In the AMPLITUDE section, enter the desired MIN LIMIT and MAX LIMIT values in the appropriate text boxes. If the amplitude discriminator measures a signal amplitude outside these limits, the E5: AMPLITUDE ERROR message is displayed on the measurement screen.
3. In the SOUND SPEED [+|-] section, enter the desired maximum percentage of variation allowed from the sound speed programmed in the FLUID menu (the default value is 20%). If the fluid sound speed exceeds the programmed nominal value by more than this percentage, the E2: SOUND SPEED ERROR message is displayed on the measurement screen.
4. In the ACCELERATION section, enter the desired upper limit value in the text box. If the measured velocity changes by more than this limit from one reading to the next, the E6: CYCLE SKIP ERROR message is displayed on the measurement screen.
5. In the COMPRESSION RATIO section, enter the desired upper limit value in the text box. If the ratio of the correlation peak value to the secondary peak value exceeds this limit, the E4: SIGNAL QUALITY ERROR message is displayed on the measurement screen.
6. In the SIGNAL LOW LIMIT section, enter the desired low limit value in the text box. If the SNR (Signal to Noise Rate) is less than this limit or the signal cannot be found when the flow is started, the E1: LOW SIGNAL ERROR message is displayed on the measurement screen.

7.3.4 Programming the ERROR LIMITS Menu (cont.)

7. There is an acceptable range for each of the parameters entered in this menu. If you enter a value outside of these limits a message similar to Figure 133 below is displayed.

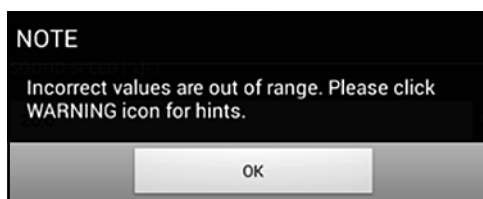



Figure 133: Out of Limits Message

Click the OK button to close the above message, then click the  icon on the ERROR LIMITS menu for help (see the example below).

SOUND SPEED VARIATION RATE incorrect value [0.0 to 10000.0 range]

Click the  button to the right of the help message. Then, enter a new value within the specified range.

8. Be sure to click the SAVE button before leaving the ERROR LIMITS menu, or all of your settings will be discarded.

Chapter 8. Error Codes and Troubleshooting

8.1 Error Codes

The bottom line of the Tablet LCD displays a single, top-priority error message during operation. This line, called the Error Line and it includes the following:

- Error Header: gives the Error Pattern and the Error Number
- Error String: gives detailed error information

8.1.1 Error Header

The possible Error Headers are listed in Table 14 below.

Table 14: Error Headers

Error Channel	Error Header
Channel 1	CH1
Channel 2	CH2
Meter	No specified channel

8.1.2 Flow Errors

Flow Errors are errors which occur while taking flow measurements. These errors can be caused by disturbances in the fluid, such as excessive particles in the flow stream or extreme temperature gradients. The errors could also be caused by an empty pipe or issues with the fluid. Flow errors are typically not caused by a malfunction of the flow measurement device, but by an issue with the fluid itself.

8.1.2a EI: Low Signal

Problem: Poor ultrasonic signal strength or the signal exceeds the programmed limit.

Cause: SNR is less than the Signal Low Limit or the signal cannot be found. Poor signal strength may be caused by a defective cable, a fluid or pipe problem, a defective transducer or a transmitter problem. A signal that exceeds the programmed limits is probably caused by an improper user value.

Action: Check the components listed above. Also, check the programmed error limits value.

8.1.2b E2: Sound Speed Error

Problem: The sound speed exceeds the programmed limits.

Cause: This error may be caused by incorrect programming, poor flow conditions or poor transducer orientation.

Action: Correct the programming errors. Be sure to check the programmed Error Limits value.

8.1.2c E3: Velocity Range

Problem: The velocity exceeds the programmed limits.

Cause: This error may be caused by improper programming, poor flow conditions or excessive turbulence.

Action: Make sure the actual flow rate is within the programmed limits. Also, check the programmed Error Limits value. Correct any fluid, pipe and transducer problems.

8.1.2d E4: Signal Quality

Problem: The signal quality is outside the programmed limits.

Cause: The peak of the upstream or downstream correlation signals has fallen below the programmed correlation peak limit. This may also be caused by a fluid, pipe or electrical problem.

Action: Check for sources of electrical interference and verify the integrity of the tablet by temporarily using the PT900 on a test fluid/pipe that is known to be good. Check the transducers and relocate them, if necessary.

8.1.2e E5: Amplitude Error

Problem: The signal amplitude exceeds the programmed limits.

Cause: Solid or liquid particulates may be present in the fluid or pipe. Poor couplant used on the clamp-on transducers;

Action: Correct any fluid and pipe problems.

8.1.2f E6: Cycle Skip

Problem: The ACCELERATION exceeds the programmed limits.

Cause: This condition is usually caused by poor flow conditions or improper transducer alignment.

Action: Correct any fluid, pipe and transducer problems.

8.2 Diagnostics

8.2.1 Introduction

This section explains how to troubleshoot the PT900 if problems arise with the transmitter, the fluid, the pipe, or the transducers. Indications of a possible problem include:

- Display of an error message on the tablet screen
- Erratic flow readings
- Readings of doubtful accuracy (i.e., readings that are not consistent with readings from another flow measuring device connected to the same process).

If any of the above conditions occurs, proceed to the instructions in the following sections.

8.2.2 Fluid and Pipe Problems

If preliminary troubleshooting with the Error Code messages indicates a possible fluid or pipe problem, proceed with this section. Read the following sections carefully to determine if the problem is indeed related to the fluid or pipe. If the instructions in this section fail to resolve the problem, contact Panametrics for assistance.

8.2.2a Fluid Problems

Most fluid-related problems result from a failure to observe the flow meter system installation instructions. Refer to Chapter 2, Installation, to correct any installation problems. If the physical installation of the system meets the recommended specifications, it is possible that the fluid itself may be preventing accurate flow rate measurements. The fluid being measured must meet the following requirements:

- The fluid must be homogeneous, single-phase, relatively clean, and flowing steadily.

Although a low level of entrained particles may have little effect on the operation of the PT900, excessive amounts of solid or gas particles will absorb or disperse the ultrasound signals. This interference with the ultrasound transmissions through the fluid will cause inaccurate flow rate measurements. In addition, temperature gradients in the fluid flow may result in erratic or inaccurate flow rate readings.

- The fluid must not cavitate near the measurement point.

Fluids with a high vapor pressure may cavitate near the measurement point. This causes problems resulting from gas bubbles in the fluid. Cavitation can usually be controlled through proper installation design.

- The fluid must not excessively attenuate ultrasound signals.

Some fluids, particularly those that are very viscous, readily absorb ultrasound energy. In such a case, an Error Code message will appear on the display screen to indicate that the ultrasonic signal strength is insufficient for reliable measurements.

- The fluid sound speed must not vary excessively.

The PT900 will tolerate relatively large changes in the fluid sound speed, as may be caused by variations in fluid composition and/or temperature. However, such changes must occur slowly. Rapid fluctuations in the fluid sound speed, to a value that is considerably different from that programmed into the PT900, will result in erratic or inaccurate flow rate readings. Refer to Chapter 4, Programming, and make sure that the appropriate sound speed is programmed into the meter.

8.2.2b Pipe Problems

Pipe-related problems may result either from a failure to observe the installation instructions in Chapter 2, Installation, or from improper programming of the meter. By far, the most common pipe problems are the following:

- The collection of material at the transducer locations.
Accumulated debris at the transducer locations will interfere with the transmission of the ultrasound signals. As a result, accurate flow rate measurements are not possible. Realignment of the transducers often cures such problems, and in some cases, wetted transducers must be used. Refer to Chapter 2, Installation, for more details on proper installation practices.
- Inaccurate pipe measurements.
The accuracy of the flow rate measurements is no better than the accuracy of the programmed pipe dimensions. Measure the pipe wall thickness and diameter with the same accuracy desired in the flow rate readings. Also, check the pipe for dents, eccentricity, weld deformity, straightness and other factors that may cause inaccurate readings. Refer to Chapter 4, Programming, for instructions on entering the pipe data.
- The inside of the pipe or pipe is not sufficiently clean.
Excessive buildup of scale, rust or debris inside the pipe will interfere with flow measurements. Generally, a thin coating or a solid well-adhered build up on the pipe wall will not cause problems. Loose scale and thick

coatings (such as tar or oil) will interfere with ultrasound transmission and may result in incorrect or unreliable flow rate measurements.

8.2.2c Transducer Problems

Ultrasonic transducers are rugged, reliable devices. However, they are subject to physical damage from mishandling and chemical attack. Contact Panametrics for assistance if you cannot solve a transducer-related problem.

8.3 Diagnostic Parameters

If you suspect fluid, pipe, transducer or electrical problems with your PT900 system, the diagnostic parameters listed in Table 15 below are available to help you troubleshoot the problem. To display these parameters, see “Displaying the Diagnostics Parameters” on page 106.

Table 15: Available Diagnostic Parameters

Parameter	Description	Good	Bad
Transit Time Up	Transit time of upstream signal	N/A	N/A
Transit Time Dn	Transit time of downstream signal	N/A	N/A
Delta T	Difference between upstream and downstream transit times	N/A	N/A
Signal Quality Up	Quality of upstream signal	1200	<400
Signal Quality Dn	Quality of downstream signal	1200	<400
Amplitude Discrete Up	Amplitude discriminator value of upstream transducer	19~29	<19 or >29
Amplitude Discrete Dn	Amplitude discriminator value of downstream transducer	19~29	<19 or >29
Signal Noise Rate Up	Signal to noise ratio of upstream signal	4	<4
Signal Noise Rate Dn	Signal to noise ratio of downstream signal	4	<4
Gain Up	Upstream gain in db	9~85	<9 or >85
Gain Dn	Downstream gain in db	9~85	<9 or >85
Peak Up	Peak value of upstream correlation signal	N/A	N/A
Peak Dn	Peak value of downstream correlation signal	N/A	N/A
Peak Percent Up	% of peak of upstream signal	N/A	N/A
Peak Percent Dn	% of peak of downstream signal	N/A	N/A

8.4 Getting Help

The HELP menu (see Figure 134 below), which is available from the APP main menu, provides information for resolving problems and answering questions. The following sub-menus are included:

- About (see page 140)
- Diagnostics (see page 141)
- Service (see page 142)
- Spare Parts (see page 143)

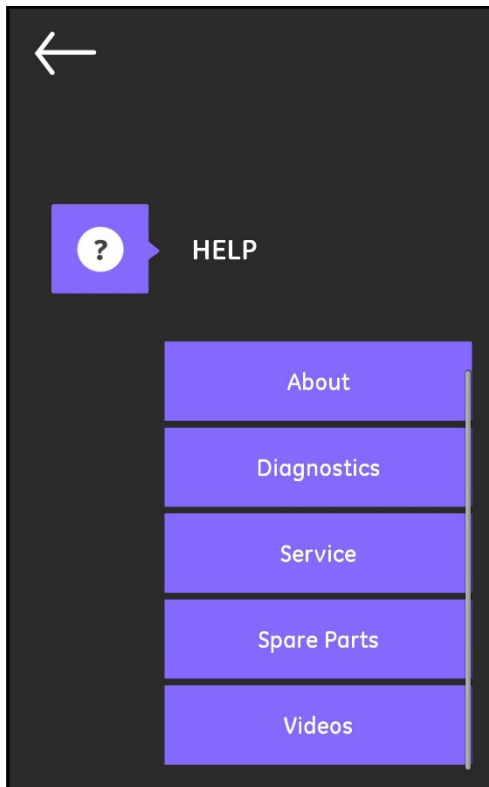

Figure 134: The HELP Menu

Important: Please contact your Panametrics sales representative at any time for help with any questions not answered in this manual.

8.4.1 The About Screen

Click on the About option to open a screen similar to Figure 135 below. This screen displays general information about the PT900 system. This information includes: model name, instrument type, software version, and the copyright year of the APP.



Figure 135: The About Screen

8.4.2 The Diagnostics Screen

Click on the Diagnostics option to open a screen similar to Figure 136 below. This screen displays the possible flow errors that can be generated by the PT900 system, such as the E1:Low Signal error shown in the example below. Just click on any of the listed error codes to display a description of that error.

Note: See “Flow Errors” on page 133 for a complete description of the PT900 error codes.

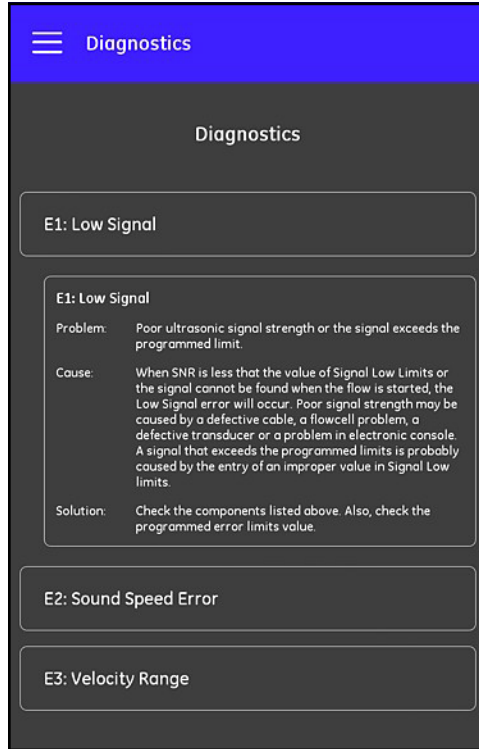

Figure 136: The Diagnostics Screen

8.4.3 The Service Screen

Click on the Service option to open a screen similar to Figure 137 below. This screen provides links to the many services provided by Panametrics for the PT900.

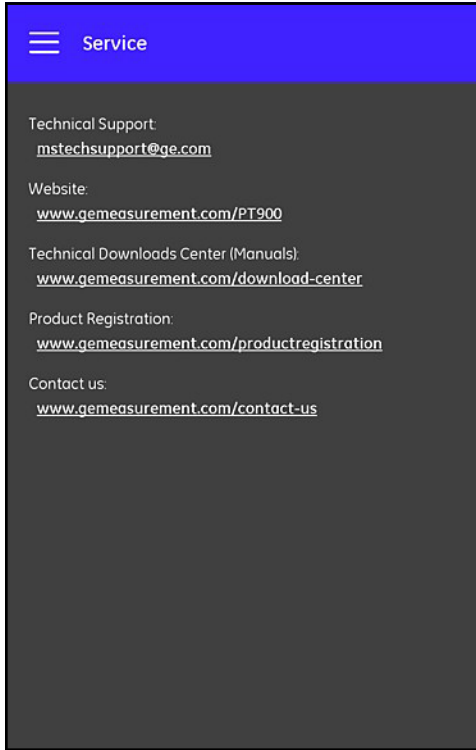

Figure 137: The Service Screen

8.4.4 The Spare Parts Screen

Click on the Spare Parts option to open a screen similar to Figure 138 below. This screen lists the spare parts available from Panametrics for the PT900 system. Just click on any of the listed parts to display a description of that part.

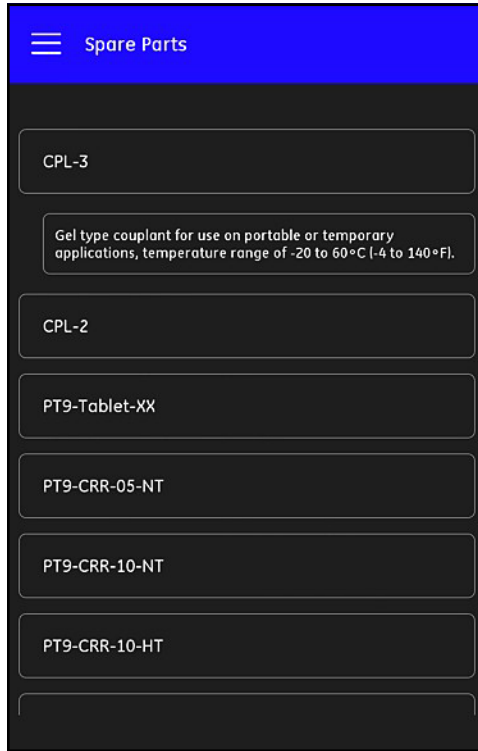

Figure 138: The Spare Parts Screen

8.5 Help Topics List

The following is a complete list of the available help topics:

1. What type of tablet may I use with the PT900 Applications?
2. Where can I get the PT900 application?
3. To update to the latest version of the PT900 APP, do I need to update both my APP and PT900 firmware?
4. I cannot connect to the PT900 transmitter with my tablet. What am I doing wrong?
5. Can someone connect to the PT900 transmitter with Bluetooth without the PT900 APP and damage my transmitter?
6. Can I work OFFLINE and save my settings before connecting to a transmitter?
7. How many PRESETs can the meter save?
8. Can I connect to more than one PT900 transmitter at a time with my APP?
9. How do I determine the material of my pipe?
10. How do I determine the SNSP of my pipe?
11. How do I determine the outer diameter of my pipe?
12. How do I determine the wall thickness of my pipe?
13. What is a pipe lining and how do I know if my pipe has a lining?
14. Do I need to turn on tracking windows? If yes, when do I turn on tracking windows?
15. If I do not know the fluid, what do I use for a sound speed?
16. How do I determine the Kinematic Viscosity of my fluid?
17. What is the difference between a wetted transducer and a clamp-on transducer?
18. What transducer should I use for my pipe?
19. How do I determine the type of transducer that I have?
20. What is wedge temperature and what temperature should I use?
21. What is Reynolds Correction Factor and should it be programmed On or Off?
22. What is Calibration Factor and should it be programmed On or Off?
23. What is traverse?
24. How many traverses should I use to install my transducers?
25. What is Transducer Spacing and how do I measure it?
26. What is signal level?
27. What is an acceptable value for signal level?
28. The meter is giving me a sound speed level. How do I know if the value is good or not?
29. What is the difference between a batch total and an inventory total?
30. What is Standard Volumetric?
31. What are the Diagnostics and what do they mean?

32. Do the diagnostic values update if the meter is showing an error code?
33. What are the Error Codes, what is the cause? How do you fix them?
34. Can you adjust the range in the graph?
35. What is the Energy Switch for?
36. What is the energy channel AVG for?
37. How do I know if my system is a heating or cooling system?
38. Does it make a difference if I put the flow measurement on the supply or return side?
39. What is Enthalpy?
40. How do I know if I should be using a default or custom enthalpy value?
41. What is General Purpose for the analog inputs?
42. What is a User Function?
43. What is a User Table?

8.6 The Quick-Start Guide

The Quick Start Guide, which can be found on your SD card, provides general instructions on using the flow meter and the APP. Start by watching the installation videos on Panametrics web site at www.gemeasurement.com/transport and then complete the following steps:

1. Check the PT900 transmitter and the tablet before use.
2. Load the APP onto tablet from either the SD card or from our web site (see the link above).
3. Turn on the transmitter by holding down the power button for more than two seconds. The green power LED indicates that the power is On.
4. Open the PT900 APP on the Tablet.
5. Connect the APP to the transmitter via Bluetooth communication.
6. Select the desired Measurement Units option and program the meter with correct pipe, fluid, transducer and placement information.
7. Install the transducers onto the pipe with the Spacing information calculated by the APP.
8. Set the tablet display to the desired values and to view the flow rate.
9. Continue with other operations, as described elsewhere in this manual.

Chapter 9. Communication

9.1 Modbus Communication

In general, the PT900 flow meter follows the standard Modbus communications protocol defined by the reference MODBUS APPLICATION PROTOCOL SPECIFICATION V1.1b. This specification is available at www.modbus.org. With this reference as a guide, the user may use any Modbus master to communicate with the flow meter.

Two limitations of this implementation are:

- The PT900 supports only four of the standard function codes. These are Read Holding Registers (0x03), Read Input Registers (0x04), Write Multiple Registers (0x10) and Read File Record (0x14).
- The flow meter needs a 15 ms gap between Modbus requests. The prime objective of the flow meter is to measure flow rate and drive the output, so the Modbus server has a low priority.

9.2 Modbus Register Map

Table 16 below lists the complete Modbus register map for the PT900.

Table 16: Modbus Register Map

	Register (in Hex)	Register (in Dec.)	Access Level	Description	RO/ RW	Format
100	100	256	User	Product Short Tag	RW	CHAR * 16
	108	264	User	Product Long Tag	RW	CHAR * 32
	118	280	User	eAllLabel	RW	CHAR * 16
	120	288	User	eAI2Label	RW	CHAR * 16
	128	296	User	eLogName	RW	CHAR * 16
	130	304	User	Product Electrical serial number	RW	CHAR * 16
	138	312	User	Product fixture serial number	RW	CHAR * 16
	140	320	User	Product transducer1 serial number	RW	CHAR * 16
	148	328	User	Product transducer2 serial number	RW	CHAR * 16
	150	336	User	Product transducer3 serial number	RW	CHAR * 16
	158	344	User	Product transducer4 serial number	RW	CHAR * 16
300	300	768	RO	Main Hardware version	RO	CHAR * 8
	304	772	RO	Option Hardware version	RO	CHAR * 8
	308	776	RO	Main Software version	RO	CHAR * 8
500	500	1280	User	Global Unit group 1 for Actual Volumetric	RW	INT32
	502	1282	User	Global Unit group 2 for Day	RW	INT32

	Register (in Hex)	Register (in Dec.)	Access Level	Description	RO/ RW	Format
	504	1284	User	Global Unit group 3 for dB	RW	INT32
	506	1286	User	Global Unit group 4 for Density	RW	INT32
	508	1288	User	Global Unit group 5 for Diamention	RW	INT32
	50A	1290	User	Global Unit group 6 for Hz	RW	INT32
	50C	1292	User	Global Unit group 7 for Viscosity	RW	INT32
	50E	1294	User	Global Unit group 8 for mA	RW	INT32
	510	1296	User	Global Unit group 9 for Mass	RW	INT32
	512	1298	User	Global Unit group 10 for Milli Second	RW	INT32
	514	1300	User	Global Unit group 11 for Nano Second	RW	INT32
	516	1302	User	Global Unit group 12 for Percent	RW	INT32
	518	1304	User	Global Unit group 13 for Second	RW	INT32
	51A	1306	User	Global Unit group 14 for Standard Volumetric	RW	INT32
	51C	1308	User	Global Unit group 15 for Therm	RW	INT32
	51E	1310	User	Global Unit group 16 for Totalizer time	RW	INT32
	520	1312	User	Global Unit group 17 for Totalizer	RW	INT32
	522	1314	User	Global Unit group 18 for Unitless	RW	INT32
	524	1316	User	Global Unit group 19 for Micro Second	RW	INT32
	526	1318	User	Global Unit group 20 for Velocity	RW	INT32
	528	1320	User	Global Unit group 21 for Accelaration	RW	INT32
	52A	1322	User	Global Unit group 22 for Energy	RW	INT32
	52C	1324	User	Global Unit group 22 for Energy	RW	INT32
	52E	1326	User	Global Unit for reserve 1	RW	INT32
	530	1328	User	Global Unit for reserve 2	RW	INT32
540	540	1344	Viewer	Batch request command	RW	INT32
	542	1346	User	inventory request command	RW	INT32
	544	1348	Viewer	system request password	RW	INT32
	546	1350	Viewer	system request command	RW	INT32
	548	1352	Viewer	system update command	RW	INT32
700	700	1792	RO	System Reported error	RO	INT32
	702	1794	RO	System Error Bitmap	RO	INT32
	704	1796	RO	System Startup error Bitmap	RO	INT32
	706	1798	RO	System Flow Ch1 error Bitmap	RO	INT32
	708	1800	RO	System Flow Ch2 error Bitmap	RO	INT32
	70A	1802	RO	System Device error Bitmap	RO	INT32
	70C	1804	RO	System Warning Bitmap	RO	INT32
720	720	1824	RO	System Power Status	RO	INT32
	722	1826	RO	battery status: charging, discharging	RO	INT32
	724	1828	RO	remaining battery capacity (%)	RO	INT32

	Register (in Hex)	Register (in Dec.)	Access Level	Description	RO/ RW	Format
	726	1830	RO	remaining battery life (minutes).	RO	INT32
	728	1832	RO	remaining time until Battery reaches full charge (minutes).	RO	INT32
	72A	1834	RO	the cell-pack's internal temperature (°C)	RO	INT32
	72C	1836	RO	the cell-pack voltage (mV)	RO	INT32
	72E	1838	RO	the current being supplied	RO	INT32
	730	1840	RO	eSystemRESVI	RO	INT32
	732	1842	RO	eSystemRESVI	RO	INT32
	734	1844	RO	eSystemRESVI	RO	INT32
C00	C00	3072	User	Analog Out Error Handling Value	RW	(IEEE 32 bit)
	C02	3074	User	Analog Out Test Value (Percent of Span)	RW	(IEEE 32 bit)
	C04	3076	User	Analog Out Zero Value	RW	(IEEE 32 bit)
	C06	3078	User	Analog Out Span Value	RW	(IEEE 32 bit)
	C08	3080	User	Analog Out Base Value	RW	(IEEE 32 bit)
	C0A	3082	User	Analog Out Full Value	RW	(IEEE 32 bit)
C40	C40	3136	User	Digital Out 1 Pulse Value	RW	(IEEE 32 bit)
	C42	3138	User	Digital Out 1 Frequency Base Value	RW	(IEEE 32 bit)
	C44	3140	User	Digital Out 1 Frequency Full Value	RW	(IEEE 32 bit)
	C46	3142	User	Digital Out 1 Alarm Value	RW	(IEEE 32 bit)
D00	D00	3328	User	Analog Out Mode	RW	INT32
	D02	3330	User	Analog Out Type	RW	INT32
	D04	3332	User	Digital Out 1 Mode	RW	INT32
	D06	3334	User	Digital Out 1 Type	RW	INT32
D20	D20	3360	User	Analog Out Measurement Type	RW	INT32
	D22	3362	User	Analog Out Error Handling	RW	INT32
D40	D40	3392	User	Digital Out 1 Pulse Measurement Type	RW	INT32
	D42	3394	User	Digital Out 1 Pulse Test Value	RW	INT32
	D44	3396	User	Digital Out 1 Pulse Error Handling	RW	INT32
	D46	3398	User	Digital Out 1 Pulse Time	RW	INT32
D60	D60	3424	User	Digital Out 1 Frequency Measurement Type	RW	INT32
	D62	3426	User	Digital Out 1 Test Frequency Value	RW	INT32
	D64	3428	User	Digital Out 1 Frequency Error Handling	RW	INT32
	D66	3430	User	Digital Out 1 Frequency Error Handling Value	RW	INT32
	D68	3432	User	Digital Out 1 Frequency Full Frequency	RW	INT32
D80	D80	3456	User	Digital Out 1 Alarm Measurement Type	RW	INT32
	D82	3458	User	Digital Out 1 Alarm Test Value	RW	INT32
	D84	3460	User	Digital Out 1 Alarm State	RW	INT32
	D86	3462	User	Digital Out 1 Alarm Type	RW	INT32

	Register (in Hex)	Register (in Dec.)	Access Level	Description	RO/ RW	Format
E00	E00	3584	RO	Analog Out Measurement Value	RO	(IEEE 32 bit)
	E02	3586	RO	Digital Out 1 Pulse Measurement Value	RO	(IEEE 32 bit)
	E04	3588	RO	Digital Out 1 Frequency Measurement Value	RO	(IEEE 32 bit)
	E06	3590	RO	Digital Out 1 Alarm Measurement Value	RO	(IEEE 32 bit)
1500	1500	5376	User	PC MODBUS baud rate	RW	INT32
	1502	5378	User	PC MODBUS parity	RW	INT32
	1504	5380	User	PC MODBUS stop bits	RW	INT32
	1506	5382	User	PC MODBUS meter addr	RW	INT32
1540	1540	5440	Viewer	Log control / status	RW	INT32
	1542	5442	Viewer	Log interval	RW	INT32
	1544	5444	Viewer	Logging time	RW	INT32
	1546	5446	Viewer	Number of variables to log	RW	INT32
	1548	5448	Viewer	eLogChannel	RW	INT32
	154A	5450	Viewer	eLogFormat	RW	INT32
	154C	5452	Viewer	eLogStartDate	RW	INT32
	154E	5454	Viewer	eLogEndtDate	RW	INT32
	1550	5456	Viewer	eLogStartTime	RW	INT32
	1552	5458	Viewer	eLogEndtTime	RW	INT32
1580	1580	5504	Viewer	variable address array	RW	INT32
15C0	15C0	5568	Viewer	Variable unit code array	RW	INT32
1740	1740	5952	RO	Number of records	RO	INT32
2000	2000	8192	User	channel 1 composite factor	RW	(IEEE 32 bit)
	2002	8194	User	channel 2 composite factor	RW	(IEEE 32 bit)
20C0	20C0	8384	User	Correlation peak low limit	RW	(IEEE 32 bit)
	20C2	8386	User	Acceleration Limit	RW	(IEEE 32 bit)
	20C4	8388	User	Velocity Low limit - Used for Volumetric low limit calculation	RW	(IEEE 32 bit)
	20C6		User	Velocity High limit - Used for Volumetric High limit calculation	RW	(IEEE 32 bit)
	20C8	8392	User	Amplitude discriminator min limit	RW	(IEEE 32 bit)
	20CA	8394	User	Amplitude discriminator max limit	RW	(IEEE 32 bit)
	20CC	8396	User	Soundspeed Plus minus limit	RW	(IEEE 32 bit)
	20CE	8398	User	signal low limit	RW	(IEEE 32 bit)
	20D0	8400	User	ePcr	RW	(IEEE 32 bit)
	20D2	8402	User	eSOSVariationRate	RW	(IEEE 32 bit)
	20D4	8404	Viewer	ePercentGain	RW	(IEEE 32 bit)
	20D6	8406	User	the maximum threshold	RW	(IEEE 32 bit)
	20D8	8408	User	the minimum threshold	RW	(IEEE 32 bit)

	Register (in Hex)	Register (in Dec.)	Access Level	Description	RO/ RW	Format
20E0	20E0	8416	User	Zero Cutoff	RW	(IEEE 32 bit)
	20E2	8418	User	DeltaT Offset	RW	(IEEE 32 bit)
	20E4	8420	User	the inputted threshold under manual mode	RW	(IEEE 32 bit)
2100	2100	8448	User	Enable Ch1	RW	INT32
	2102	8450	User	Enable Ch2	RW	INT32
	2104	8452	Viewer	elmpulseResponse	RW	INT32
	2106	8454	Viewer	elmpulseRespCmd	RW	INT32
	2108	8456	User	define how to find the peak of the correlation signal	RW	INT32
	210A	8458	User	define how to search the threshold	RW	INT32
21C0	21C0	8640	User	Response Time	RW	INT32
	21C2	8642	User	Response	RW	INT32
	21C4	8644	User	Sample Size	RW	INT32
2200	2200	8704	RO	Average Velocity	RO	(IEEE 32 bit)
	2202	8706	RO	Average Volumetric	RO	(IEEE 32 bit)
	2204	8708	RO	Average Standard Volumetric	RO	(IEEE 32 bit)
	2206	8710	RO	Average Mass Flow	RO	(IEEE 32 bit)
	2208	8712	RO	Average TransitTime	RO	(IEEE 32 bit)
2240	2240	8768	RO	Average Batch fwd totals	RO	(IEEE 32 bit)
	2242	8770	RO	Average Batch rev totals	RO	(IEEE 32 bit)
	2244	8772	RO	Average Batch net totals	RO	(IEEE 32 bit)
	2246	8774	RO	Average Batch totals time	RO	(IEEE 32 bit)
	2248	8776	RO	Average inventory fwd totals	RO	(IEEE 32 bit)
	224A	8778	RO	Average inventory rev totals	RO	(IEEE 32 bit)
	224C	8780	RO	Average inventory net totals	RO	(IEEE 32 bit)
	224E	8782	RO	Average inventory totals time	RO	(IEEE 32 bit)
2400	2400	9216	User	Ch1 Pipe Inner Diameter	RW	(IEEE 32 bit)
	2402	9218	User	Ch1 Pipe Outer Diameter	RW	(IEEE 32 bit)
	2404	9220	User	Ch1 Pipe Wall Thickness	RW	(IEEE 32 bit)
	2406	9222	User	Ch1 Pipe Soundspeed	RW	(IEEE 32 bit)
	2408	9224	User	Ch1 Lining Thickness	RW	(IEEE 32 bit)
	240A	9226	User	Ch1 Lining Soundspeed	RW	(IEEE 32 bit)
	240C	9228	User	Ch1 XDR wedge angle	RW	(IEEE 32 bit)
	240E	9230	User	Ch1 XDR wedge time	RW	(IEEE 32 bit)
	2410	9232	User	Ch1 Wedge Sound speed	RW	(IEEE 32 bit)
	2412	9234	User	Ch1 Fluid Sound speed	RW	(IEEE 32 bit)
	2414	9236	User	Ch1 Fluid Sound speed Min	RW	(IEEE 32 bit)
	2416	9238	User	Ch1 Fluid Sound speed Max	RW	(IEEE 32 bit)

	Register (in Hex)	Register (in Dec.)	Access Level	Description	RO/ RW	Format
	2418	9240	User	ChI Fluid Static Density	RW	(IEEE 32 bit)
	241A	9242	User	ChI Fluid Reference Density	RW	(IEEE 32 bit)
	241C	9244	User	Fluid Temperature	RW	(IEEE 32 bit)
	241E	9246	User	ChI XDR space	RW	(IEEE 32 bit)
	2420	9248	User	ChI Calibration Factor	RW	(IEEE 32 bit)
	2422	9250	User	ChI Kinematic Viscosity	RW	(IEEE 32 bit)
	2424	9252	User	ChI XDR Temperature	RW	(IEEE 32 bit)
	2426	9254	User	eChI Goycol	RW	(IEEE 32 bit)
2500	2500	9472	User	ChI Pipe Material	RW	INT32
	2502	9474	User	ChI Lining Material	RW	INT32
	2504	9476	User	ChI XDR Type	RW	INT32
	2506	9478	User	ChI XDR frequency	RW	INT32
	2508	9480	User	ChI XDR wedge type	RW	INT32
	250A	9482	User	ChI Fluid Type	RW	INT32
	250C	9484	User	ChI Lining existence	RW	INT32
	250E	9486	User	ChI Traverse number	RW	INT32
	2510	9488	User	ChI Couplant type	RW	INT32
2540	2540	9536	User	ChI Enable Reynolds Correction	RW	INT32
	2542	9538	User	ChI Enable Active MultiK	RW	INT32
	2544	9540	User	ChI MultiK Type	RW	INT32
	2546	9542	User	ChI MultiK Pairs	RW	INT32
	2548	9544	User	eChI Density	RW	INT32
	254A	9546	User	eChI DensityPairs	RW	INT32
2580	2580	9600	User	ChI Peak%	RW	INT32
	2582	9602	User	ChI Min Peak%	RW	INT32
	2584	9604	User	ChI Max Peak%	RW	INT32
	2586	9606	User	ChI Enable Tracking Windows	RW	INT32
2600	2600	9728	RO	ChI Velocity	RO	(IEEE 32 bit)
	2602	9730	RO	ChI Volumetric	RO	(IEEE 32 bit)
	2604	9732	RO	ChI Standard Volumetric	RO	(IEEE 32 bit)
	2606	9734	RO	ChI Mass Flow	RO	(IEEE 32 bit)
2640	2640	9792	RO	ChI Batch fwd totals	RO	(IEEE 32 bit)
	2642	9794	RO	ChI Batch rev totals	RO	(IEEE 32 bit)
	2644	9796	RO	ChI Batch net totals	RO	(IEEE 32 bit)
	2646	9798	RO	ChI Batch totals time	RO	(IEEE 32 bit)
	2648	9800	RO	ChI inventory fwd totals	RO	(IEEE 32 bit)
	264A	9802	RO	ChI inventory rev totals	RO	(IEEE 32 bit)
	264C	9804	RO	ChI inventory net totals	RO	(IEEE 32 bit)

	Register (in Hex)	Register (in Dec.)	Access Level	Description	RO/ RW	Format
	264E	9806	RO	Ch1 inventory totals time	RO	(IEEE 32 bit)
2680	2680	9856	RO	Ch1 Transit Time Up	RO	(IEEE 32 bit)
	2682	9858	RO	Ch1 Transit Time Dn	RO	(IEEE 32 bit)
	2684	9860	RO	Ch1 DeltaT	RO	(IEEE 32 bit)
	2686	9862	RO	Ch1 Up Signal Quality	RO	(IEEE 32 bit)
	2688	9864	RO	Ch1 Dn Signal Quality	RO	(IEEE 32 bit)
	268A	9866	RO	Ch1 Up Amp Disc	RO	(IEEE 32 bit)
	268C	9868	RO	Ch1 Dn Amp Disc	RO	(IEEE 32 bit)
	268E	9870	RO	Ch1 SNR on UP channel	RO	(IEEE 32 bit)
	2690	9872	RO	Ch1 SNR on DOWN channel	RO	(IEEE 32 bit)
	2692	9874	RO	Ch1 Time in buffer on Up channel	RO	(IEEE 32 bit)
	2694	9876	RO	Ch1 Time in buffer on Dn channel	RO	(IEEE 32 bit)
	2696	9878	RO	Ch1 Signal Gain Up	RO	(IEEE 32 bit)
	2698	9880	RO	Ch1 Signal Gain Down	RO	(IEEE 32 bit)
	269A	9882	RO	Ch1 Partial Corrolatoin Ratio Up	RO	(IEEE 32 bit)
	269C	9884	RO	Ch1 Partial Corrolatoin Ratio Dn	RO	(IEEE 32 bit)
26C0	26C0	9920	RO	Ch1 Sound Speed	RO	(IEEE 32 bit)
	26C2	9922	RO	Ch1 Current Reynolds Number	RO	(IEEE 32 bit)
	26C4	9924	RO	Ch1 Current Correction Factor	RO	(IEEE 32 bit)
	26C6	9926	RO	Ch1 Path Length P	RO	(IEEE 32 bit)
	26C8	9928	RO	Ch1 Axial Length L	RO	(IEEE 32 bit)
2700	2700	9984	RO	Ch1 Up +- Peak	RO	INT32
	2702	9986	RO	Ch1 Dn +- Peak	RO	INT32
	2704	9988	RO	Ch1 dynamic threshold on UP channel	RO	INT32
	2706	9990	RO	Ch1 dynamic threshold on DOWN channel	RO	INT32
2800	2800	10240	User	Ch2 Pipe Inner Diameter	RW	(IEEE 32 bit)
	2802	10242	User	Ch2 Pipe Outer Diameter	RW	(IEEE 32 bit)
	2804	10244	User	Ch2 Pipe Wall Thickness	RW	(IEEE 32 bit)
	2806	10246	User	Ch2 Pipe Soundspeed	RW	(IEEE 32 bit)
	2808	10248	User	Ch2 Lining Thickness	RW	(IEEE 32 bit)
	280A	10250	User	Ch2 Lining Soundspeed	RW	(IEEE 32 bit)
	280C	10252	User	Ch2 XDR wedge angle	RW	(IEEE 32 bit)
	280E	10254	User	Ch2 XDR wedge time	RW	(IEEE 32 bit)
	2810	10256	User	Ch2 Wedge Sound speed	RW	(IEEE 32 bit)
	2812	10258	User	Ch2 Fluid Sound speed	RW	(IEEE 32 bit)
	2814	10260	User	Ch2 Fluid Sound speed Min	RW	(IEEE 32 bit)
	2816	10262	User	Ch2 Fluid Sound speed Max	RW	(IEEE 32 bit)
	2818	10264	User	Ch2 Fluid Static Density	RW	(IEEE 32 bit)

	Register (in Hex)	Register (in Dec.)	Access Level	Description	RO/ RW	Format
	281A	10266	User	Ch2 Fluid Reference Density	RW	(IEEE 32 bit)
	281C	10268	User	Ch2 Fluid Temperature	RW	(IEEE 32 bit)
	281E	10270	User	Ch2 XDR space	RW	(IEEE 32 bit)
	2820	10272	User	Ch2 Calibration Factor	RW	(IEEE 32 bit)
	2822	10274	User	Ch2 Kinematic Viscosity	RW	(IEEE 32 bit)
	2824	10276	User	Ch2 XDR Temperature	RW	(IEEE 32 bit)
	2826	10278	User	eCh2 Goycol	RW	(IEEE 32 bit)
2900	2900	10496	User	Ch2 Pipe Material	RW	INT32
	2902	10498	User	Ch2 Lining Material	RW	INT32
	2904	10500	User	Ch2 XDR Type	RW	INT32
	2906	10502	User	Ch2 XDR frequency	RW	INT32
	2908	10504	User	Ch2 XDR wedge type	RW	INT32
	290A	10506	User	Ch2 Fluid Type	RW	INT32
	290C	10508	User	Ch2 Lining existence	RW	INT32
	290E	10510	User	Ch2 Traverse number	RW	INT32
	2910	10512	User	Ch2 Couplant type	RW	INT32
2940	2940	10560	User	Ch2 Enable Reynolds Correction	RW	INT32
	2942	10562	User	Ch2 Enable Active MultiK	RW	INT32
	2944	10564	User	Ch2 MultiK Type	RW	INT32
	2946	10566	User	Ch2 MultiK Pairs	RW	INT32
	2948	10568	User	eCh2 Density	RW	INT32
	294A	10570	User	eCh2 DensityPairs	RW	INT32
2980	2980	10624	User	Ch2 Peak%	RW	INT32
	2982	10626	User	Ch2 Min Peak%	RW	INT32
	2984	10628	User	Ch2 Max Peak%	RW	INT32
	2986	10630	User	Ch2 Enable Tracking Windows	RW	INT32
2A00	2A00	10752	RO	Ch2 Velocity	RO	(IEEE 32 bit)
	2A02	10754	RO	Ch2 Volumetric	RO	(IEEE 32 bit)
	2A04	10756	RO	Ch2 Standard Volumetric	RO	(IEEE 32 bit)
	2A06	10758	RO	Ch2 Mass Flow	RO	(IEEE 32 bit)
2A40	2A40	10816	RO	Ch2 Batch fwd totals	RO	(IEEE 32 bit)
	2A42	10818	RO	Ch2 Batch rev totals	RO	(IEEE 32 bit)
	2A44	10820	RO	Ch2 Batch net totals	RO	(IEEE 32 bit)
	2A46	10822	RO	Ch2 Batch totals time	RO	(IEEE 32 bit)
	2A48	10824	RO	Ch2 inventory fwd totals	RO	(IEEE 32 bit)
	2A4A	10826	RO	Ch2 inventory rev totals	RO	(IEEE 32 bit)
	2A4C	10828	RO	Ch2 inventory net totals	RO	(IEEE 32 bit)
	2A4E	10830	RO	Ch2 inventory totals time	RO	(IEEE 32 bit)

	Register (in Hex)	Register (in Dec.)	Access Level	Description	RO/ RW	Format
2A80	2A80	10880	RO	Ch2 Transit Time Up	RO	(IEEE 32 bit)
	2A82	10882	RO	Ch2 Transit Time Dn	RO	(IEEE 32 bit)
	2A84	10884	RO	Ch2 DeltaT	RO	(IEEE 32 bit)
	2A86	10886	RO	Ch2 Up Signal Quality	RO	(IEEE 32 bit)
	2A88	10888	RO	Ch2 Dn Signal Quality	RO	(IEEE 32 bit)
	2A8A	10890	RO	Ch2 Up Amp Disc	RO	(IEEE 32 bit)
	2A8C	10892	RO	Ch2 Dn Amp Disc	RO	(IEEE 32 bit)
	2A8E	10894	RO	Ch2 SNR on UP channel	RO	(IEEE 32 bit)
	2A90	10896	RO	Ch2 SNR on DOWN channel	RO	(IEEE 32 bit)
	2A92	10898	RO	Ch2 Time in buffer on Up channel	RO	(IEEE 32 bit)
	2A94	10900	RO	Ch2 Time in buffer on Dn channel	RO	(IEEE 32 bit)
	2A96	10902	RO	Ch2 Signal Gain Up	RO	(IEEE 32 bit)
	2A98	10904	RO	Ch2 Signal Gain Down	RO	(IEEE 32 bit)
	2A9A	10906	RO	Ch2 Partial Corrolatoin Ratio Up	RO	(IEEE 32 bit)
	2A9C	10908	RO	Ch2 Partial Corrolatoin Ratio Dn	RO	(IEEE 32 bit)
2AC0	2AC0	10944	RO	Ch2 Sound Speed	RO	(IEEE 32 bit)
	2AC2	10946	RO	Ch2 Current Reynolds Number	RO	(IEEE 32 bit)
	2AC4	10948	RO	Ch2 Current Correction Factor	RO	(IEEE 32 bit)
	2AC6	10950	RO	Ch2 Path Length P	RO	(IEEE 32 bit)
	2AC8	10952	RO	Ch2 Axial Length L	RO	(IEEE 32 bit)
2B00	2B00	11008	RO	Ch2 Up +- Peak	RO	INT32
	2B02	11010	RO	Ch2 Dn +- Peak	RO	INT32
	2B04	11012	RO	Ch2 dynamic threshold on UP channel	RO	INT32
	2B06	11014	RO	Ch2 dynamic threshold on DOWN channel	RO	INT32
3000	3000	12288	User	eSupplyTempLow	RW	(IEEE 32 bit)
	3002	12290	User	eEnergyRRWRESV1	RW	(IEEE 32 bit)
	3004	12292	User	eReturnTempLow	RW	(IEEE 32 bit)
	3006	12294	User	eEnergyRRWRESV2	RW	(IEEE 32 bit)
	3008	12296	User	Analog Input 1 Base Value	RW	(IEEE 32 bit)
	300A	12298	User	Analog Input 1 Full Value	RW	(IEEE 32 bit)
	300C	12300	User	Analog Input 2 Base Value	RW	(IEEE 32 bit)
	300E	12302	User	Analog Input 2 Full Value	RW	(IEEE 32 bit)
	3010	12304	User	Analog Input 1 Zero Cali Value	RW	(IEEE 32 bit)
	3012	12306	User	Analog Input 1 Span Cali Value	RW	(IEEE 32 bit)
	3014	12308	User	Analog Input 2 Zero Cali Value	RW	(IEEE 32 bit)
	3016	12310	User	Analog Input 2 Span Cali Value	RW	(IEEE 32 bit)
3100	3100	12544	User	eEnergyEnable	RW	INT32
	3102	12546	User	eEnergySystem	RW	INT32

	Register (in Hex)	Register (in Dec.)	Access Level	Description	RO/ RW	Format
	3104	12548	User	eFlowMeasure	RW	INT32
	3106	12550	User	eEnthalpyCalc	RW	INT32
	3108	12552	User	eSupplyTemp	RW	INT32
	310A	12554	User	eReturnTemp	RW	INT32
	310C	12556	User	eEnergyIRWRSEV1	RW	INT32
	310E	12558	User	eAllFunction	RW	INT32
	3110	12560	User	eEnergyIRWRSEV2	RW	INT32
	3112	12562	User	eAllFunction	RW	INT32
	3114	12564	User	eEnergyChannel	RW	INT32
	3116	12566	User	eEnergyPoint	RW	INT32
	3118	12568	User	eAllPairs	RW	INT32
	311A	12570	User	eAllPairs	RW	INT32
	311C	12572	User	eExtPwrEnable	RW	INT32
	311E	12574	User	enable power saving mode(long battery mode)	RW	INT32
	3120	12576	User	Measurement Time during power saving mode	RW	INT32
	3122	12578	User	Sleep Time during power saving mode	RW	INT32
3200	3200	12800	RO	eAllCurrent	RO	(IEEE 32 bit)
	3202	12802	RO	eAI2Current	RO	(IEEE 32 bit)
	3204	12804	RO	eAllVal	RO	(IEEE 32 bit)
	3206	12806	RO	eAllVal	RO	(IEEE 32 bit)
	3208	12808	RO	eEnergy	RO	(IEEE 32 bit)
3300	3300	13056	RO	eAllSample	RO	INT32
	3302	13058	RO	eAI2Sample	RO	INT32

9.3 Bluetooth Communication

The PT900 system uses the Bluetooth protocol for communication between the transmitter and the tablet. To protect the security of the product and the user data, a proprietary protocol based on the common Bluetooth 4.0 protocol was developed.

For details of the Bluetooth communication mode, refer to Bluetooth Spec 4.0.

Note: The PT900 transmitter does not automatically relink to a previously paired tablet, and it does not automatically link to an unpaired tablet. You must use the tablet APP to initiate the pairing of an unpaired transmitter. However, the transmitter might still be paired with other tablets.

Appendix A. Specifications

A.1 Operation and Performance

Fluid Types

Liquids: Acoustically conductive fluids, including most clean liquids, and many liquids with limited amounts of entrained solids or gas bubbles

Flow Measurement

Patented Correlation Transit-Time™ mode

Pipe Sizes

Standard: 0.5 to 24 in. (15 to 600 mm)

Optional: up to 300 in. (7500 mm) available upon request

Pipe Wall Thickness

up to 3 in. (76.2 mm)

Pipe Material

All metals and most plastics

Consult Panametrics for concrete, composite materials and highly corroded or lined pipes.

Accuracy

±1% of reading (2in./50mm or greater pipe sizes)

±2% of reading (0.5in./15mm to <2in./50mm pipe sizes)

Installation assumes a fully developed symmetrical flow profile (typically 10 pipe diameters upstream and 5 pipe diameters downstream of straight pipe run). Final installation accuracy is a function of multiple factors including fluid, temperature range, pipe centricity among other factors.

Repeatability

±0.2% of reading

Range (Bidirectional)

0.1 to 40 ft/s (0.03 to 12.19 m/s)

Response Time

Up to 2 Hz

Measurement Parameters

Velocity, Volume, Mass, Energy, Total Flow

Channels

1 or 2 channels

A.2 PT900 Flow Transmitter

Enclosure

IP65 rating

Specifications

Weight: 3 lb (1.4 kg)

Size (h x w x md): 7.9 x 4.3 x 1.5 in. (200 x 109 x 38 mm)

Mounting: Soft strap around pipe or magnetic clamp

Analog Inputs

4-20 mA (qty 2)

Analog Output

4-20 mA (qty 1)

Digital Output

Pulse (Totalizer), Frequency, Alarm (qty 1)

Digital Communication

- Modbus via RS485 Port
- Bluetooth® Wireless
- Micro-USB Port

Battery

Type: Lithium Ion (high-energy, rechargeable)

Life (continuous operation): 18-20 hours

Life (power saver mode): >4 days

Charger: 100 to 240 VAC (50/60/Hz)

Charging Time: Up to 3 hours (from 0% to 100%)

Operating Temperature

Charge: 0 to 45°C (32 to 113°F)

Discharge: -20 to 55°C (-4 to 131°F)

Storage Temperature

-20 to 60°C (-4 to 140°F)

Electronics Classifications

- CE (EMC Directive) IEC 61326-1:2013, IEC 61326-2-3:2013, LVD 2006/95/EC, EN 61010-1 2010
- ANSI/UL STD. 61010-1, CAN/CSA STD. C22.2 NO. 61010-1
- WEEE Compliant (Directive 2012/19/EU)
- RoHS Compliant (Directive 2002/95/EC)

A.3 User Interface

Display

Requires a tablet with Android operating system (version 4.4 or greater), LCD capacitive touchscreen, 800 x 1280 resolution

Dimensions

- 7 in. Tablet: 7.75 x 4.75 x 0.75 in. (196 x 120 x 19 mm) typical
- 8 in. Tablet: 8.75 x 6.00 x 0.75 in. (222 x 152 x 19 mm) typical

Battery Life

>12 hours of continuous use typical (based on specific tablet)

Battery Charger

100 to 250 VAC, 50/60Hz

Operating Temperature

0 to 50°C (32 to 122°F)

Communication with Flow Transmitter

Bluetooth®

A.4 Software Application (PT900 APP)

Intuitive, Swipe Screen Interface

- Colorful, icon-driven design
- Tutorial-style programming
- Site parameter presets
- Multiple display options
- Extensive online help

Languages

English, Arabic, Chinese (Simplified), Dutch, French, German, Italian, Japanese, Korean, Portuguese, Russian, Spanish, Swedish, Turkish

Installing the PT900 APP

- File provided on SD card
- Free download from Google Play Store
- Free download from Panametrics website (QR code available)

A.5 Clamp-On Transducers

Temperature Range*

Standard: -40 to 302°F (-40 to 150°C)

Optional: -328 to 752°F (-200 to 400°C)

*See individual transducer model specifications for exact temperature range

Mounting

- New PT9 clamping fixture for pipes 2 in. (50 mm)
- CF-LP clamping fixture for 0.5 in. (15 mm) to 2 in. (50 mm) pipes

PT9 Transducer Cables

Standard Length: 25 ft (8 m)

Maximum Length: 100 ft (30 m)

Temperature Range: -40° to 302°F (-40° to 150°C)

A.6 Accessories

Cases

Standard: Soft nylon carry bag with strap and dedicated equipment dividers

Optional: Hard case with wheels and dedicated equipment compartments

Cables

Input and Output Cables: Analog and Digital

Cable Adapters: TNC to BNC or UTDR connectors

A.7 Options

Tablet

- Android operating system (version 4.4 or higher)
- Protective case

Energy Measurement Kit

The optional Energy Measurement Kit calculates energy flow rate and totalized energy.

- Temperature Transmitter: loop-powered, 4-wire PT1000 surface-mount RTDs, NIST-certified
- Accuracy: $\pm 0.12^{\circ}\text{C}$ ($\pm 0.22^{\circ}\text{F}$) of reading
- Range: 0 to 149°C (32 to 300°F) standard

Panametrics PocketMike Thickness Gauge

- Compact stainless steel design, IP67
- Pivoting, high-contrast LCD display
- Easy operation via four keys
- Integrated, exchangeable 5 MHz probe
- Range from 1 to 250 mm (0.040 to 10 in.)
- Standard AA batteries

Spare Battery

Battery Pack: Lithium Ion, high-energy, rechargeable

Battery Charger: 100 to 240 VAC (50/60/Hz)

Cable Adapter

TNC to BNC or UTXDR connectors

A.8 Customer Cable Requirements for AIO/DIO Connections

- Diameter range of Customer Cable for AIO/DIO connections:
5 to 8 mm
- Temperature range of customer cable for AIO and DIO connections:
 14° to 131°F (-10° to 55°C)
- Conductor cross section range according to CE and UL standards:
20 to 28 AWG

[no content intended for this page]

B.2 Initial Settings

The values for the parameter settings immediately after initial installation of the meter and verification of proper operation should be entered in Table 18 below.

Table 18: Initial System Parameter Settings

Parameter	Initial Value
Pipe OD	
Pipe ID	
Pipe Wall Thickness	
Pipe Material	
Pipe Sound speed	
Lining Thickness	
Lining Material	
Transducer ID	
Transducer Frequency	
Transducer Wedge Type	
Transducer Wedge Angle	
Transducer Wedge SOS	
Transducer TW	
Traverses	
Fluid Type	
Fluid SOS	
Fluid Minimum SOS	
Fluid Maximum SOS	
Fluid Temperature	
Transducer Spacing	

B.3 Initial Diagnostic Parameters

The values for the transducer signal diagnostic parameters immediately after initial installation of the meter and verification of proper operation should be entered in Table 19 below. These initial values can then be compared to current values to help diagnose any future malfunction of the system.

Table 19: Initial Diagnostic Parameters

Parameter	Initial Value
Velocity	
Actual Volumetric	
Standardized Volumetric	
Fwd. Batch Totals	
Rev Batch Totals	
Net Batch Totals	
Batch Totalizer Time	
Fwd. Inventory Totals	
Rev Inventory Totals	
Net Inventory Totals	
Inventory Totalizer Time	
Mass Flow	
Sound Speed	
Reynolds Number	
Kfactor	
Transit Time Up	
Transit Time Dn	
DeltaT	
Up Signal Quality	
Signal Quality	
Amp Disc Up	
Dn Amp Disc Dn	
SNR Up	
SNR Dn	

Table 19: Initial Diagnostic Parameters (cont.)

Parameter	Initial Value
ActiveTW Up	
ActiveTW Dn	
Gain Up	
Gain Dn	
Error Status	
Reported Error	
Peak Up	
Peak Dn	
Peak % Up	
Peak % Dn	

A	
About Screen.....	140
Adding a Log.....	108
Analog Inputs	
Calibrating	123
Configuring.....	87
Analog Inputs and Outputs, Connecting	37
Analog Outputs	
Available Data Sources	89, 99
Calibrating	122
Configuring.....	89
APP (PT900)	
Error Codes	133, 141
Getting from Google Play Store	46
Getting from SD Card.....	46
Installing.....	47
Installing or Updating	45
Languages	50, 117, 159
License Agreement.....	50
Main Menu Screen	61
Measurement Screen	97
Setting Up.....	49
Slide Menu Screen.....	62
Specifications.....	159
Version	45
B	
Battery Pack	
Charging and Storing.....	39
Disposal.....	41
Installing.....	6
Maintenance.....	38
Remaining Time.....	117
Replacing.....	40
Specifications.....	158
Bluetooth	
Communication	38, 156
Pairing Confirmation	54
C	
Cable Requirements	161

Calibrate Factor.....	77
Calibrating	
Analog Inputs	123
Analog Outputs	122
Totalizer	125
CALIBRATION Menu.....	121
Carrier Case, Hard (with contents)	5
Charging the Battery Pack.....	39
Charging the Transmitter and Tablet.....	45
Clamp-On Fixture	
See Fixture	
Communication	
Bluetooth.....	38, 156
Modbus.....	147
Couplant, Applying.....	18
D	
Data Records	
Initial Diagnostic Parameters	165
Initial Settings	164
Service Record.....	163
Data Sources, Analog Outputs	89, 99
Decimal Format, Display.....	101
Deleting a Log	111
Density Table	85
Device Information, Transmitter	116
Diagnostics	
Available Parameters.....	138
Displaying Parameters.....	106
Initial Parameter Values.....	165
Parameter Values.....	138
Troubleshooting Guide.....	135
Digital Output	
Configuring	90
Connecting.....	36
Dimensions, Pipe	68

Display	
Decimal Format.....	101
Diagnostic Parameters.....	106
Graphical Format.....	103
Measurement Screen, Typical.....	97
Multiple Measurements.....	101
Single Measurement.....	102
Totalizer Screen.....	105
Variables Available.....	99
Disposing of the Battery Pack.....	41
Document Number.....	i
E	
Editing a Log.....	112
Electrical Connections	
Analog Inputs and Outputs.....	37
Digital Output.....	36
Energy Cables.....	37
Line Power.....	33
Requirements.....	33
Transducers.....	35
Transmitter Power.....	34
USB Cable.....	38
Energy Cables (Optional), Connecting.....	37
ENERGY Option, Programming.....	85
Enthalpy Calculation.....	85
Error Codes, PT900 APP.....	133, 141
ERROR LIMITS Menu.....	130
Errors, Flow.....	133, 141
Even-Transpose	
Installation (greater than 305 mm Spacing).....	28
Installation (less than 305 mm Spacing).....	21
F	
FCC Rules/Industry Canada License.....	xii
Fixture	
Chain Installation.....	12
Mounting, PT9.....	9
Flow Errors.....	133

Fluid

Available Types72
 Density Table 85
 Menu70
 Problems.....136

G

Google Play Store, Getting PT900 APP..... 46

Graphical Display

Configuring104
 Viewing.....103

H

HELP

Menu139
 Topics List144

I

Initial Settings Record.....164
 INPUTS Menu.....87

K

K-Factor77
 Kinematic Viscosity71
 Korean KCC Warning xiv

L

Label, Serial Number..... 33, 52
 Languages, PT900 APP 50, 117, 159
 LED Indicators, Transmitter42
 License Agreement, PT900 APP.....50
 Line Power, Connecting33
 Lining, Pipe.....69
 Links to Services.....142

Logs	
Adding.....	108
Configuring.....	107
Deleting.....	111
Editing.....	112
Menu.....	110
Parameters.....	109
Stopping.....	111
Viewing.....	113
M	
Main Menu Screen.....	61
Maintenance, Battery Pack.....	38
Materials, Pipe.....	68
Measurements	
Setting Up Screen.....	98
Typical Screen.....	97
Viewing Multiple.....	100
Menu.....	63
CALIBRATION.....	121
ERROR LIMITS.....	130
FLUID.....	70
HELP.....	139
INPUTS.....	87
LOGS.....	110
METER SETUP.....	124
OUTPUTS.....	88
PIPE.....	67
PLACEMENT.....	78
PROGRAM.....	65
Program Options.....	83
SERVICE.....	121
TESTING.....	127
TRANSDUCERS.....	73
TRANSMITTER.....	115
UNITS OF MEASUREMENT.....	63
USER FUNCTIONS.....	93
Meter Factor.....	76
METER SETUP Menu.....	124

Modbus	
Communication.....	147
Configuring Output.....	92
Register Map	147
Multiple Measurements, Displaying	101
	O
Odd-Traversal, Installation.....	22
Operators, User Functions.....	94
OUTPUTS Menu	88
	P
Pairing	
Confirmation	54
Initial Setup	52
Transmitter List	56
Parameters	
Logging.....	109
Transducers.....	74
Peak Detect, Programming.....	126
Pipe	
Dimensions.....	68
Lining	69
Materials	68
Menu.....	67
Problems.....	137
PLACEMENT Menu	78
Power Button, Transmitter.....	42
Power Saving Mode, Programming.....	125
Powering the Transmitter On and Off	41
Problems	
Fluid.....	136
Pipe.....	137
Transducer	138
Program Channel Menu.....	65
Program Options Menu.....	83

PT900	
Electrical Connections	33
Packed in Hard Carrier Case	5
Software, Updating.....	118
System Description.....	1
Typical Installation	8
Unpacking	4
PT900 Transmitter	
See Transmitter	
Publication Date.....	i
	Q
QR Code, Downloading New PT900 APP Version	46
Quick-Start Guide	146
	R
Register Map, Modbus.....	147
Registration, Panametrics Product	, 1, 51
Regulatory Compliance.....	, 158
Replacing the Battery Pack	40
Return Policy	178
Return Temperature	85
Reynolds Correction Factor.....	76
RoHS Compliance	xi
	S
Safety	
Auxiliary Equipment	ix
General Issues	viii
Personal Equipment.....	x
Saving Your Settings.....	126
SD Card	
Getting New PT900 APP.....	46
Quick-Start Guide	146
Service Links	142
SERVICE Menu.....	121
Service Programs	x
Service Record	163
Settings, Saving	126
Single Measurement, Displaying.....	102
Slide Menu Screen	62

Software, Transmitter	118
Sound Speed	
Entering	71
Validation	82
Spacing Calculation, Transducers	9
Spacing, Transducers	79
Spare Parts	143
Specifications	
Accessories	160
Battery Pack	158
Clamp-On Transducers	160
Flow Transmitter	158
Operation and Performance	157
Options	161
Software Application (PT900 APP)	159
User Interface	159
Stopping a Log	111
Storing the Battery Pack	39
Supply Temperature	85
Support	
Customer Support Centers	4
Panametrics Services	x
T	
Tablet	
Charging	45
Pairing to Transmitter	49
Taiwan Warning Letter	xiv
Terms and Conditions	x
Test	
Watchdog	128
Wave Sample Channel	129
TESTING Menu	127
Threshold, Programming	126
Totalizer	
Calibrating	125
Displaying	105
Tracking Window	72
Transducer Holders, Checking	16
Transducer Spacing, Custom	80

Transducers	
Couplant, Applying.....	18
Holders.....	16
Installing.....	17
Menu.....	73
Parameters.....	74
PLACEMENT Menu.....	78
Problems.....	138
Spacing.....	79
Spacing Calculation.....	9
Specifications.....	160
Transmitter Connections.....	35
Transmitter	
CALIBRATION Menu.....	121
Charging.....	45
Device Information.....	116
ERROR LIMITS Menu.....	130
Label, Serial Number.....	33, 52
LED Indicators.....	42
Menu.....	115
METER SETUP Menu.....	124
Mounting Options.....	7
Pairing List.....	56
Pairing to Tablet.....	49, 52
Power Button.....	42
Power Connection.....	34
Powering On and Off.....	41
SERVICE Menu.....	121
Software, Updating.....	118
Specifications.....	158
TESTING Menu.....	127
Transducer Connections.....	35
USB Port.....	38
Traverse Configuration.....	78
Typographical Conventions.....	vii
U	
Units of Measurement, Selecting.....	63
Unpacking the PT900.....	4
USB Port, Using.....	38

USER FUNCTIONS Menu	93
User Functions Operators.....	94
User Interface	
Specifications	159
User Tables.....	95
V	
Version, Checking PT900 APP.....	45
Viewing a Log	113
Viewing Measurements.....	100
W	
Warranty.....	, 177
Watchdog Test	128
Wave Sample Channel Test.....	129
WEEE Compliance	xi
Wireless Interface	
See Bluetooth	
Z	
Zero Flow Validation.....	81

Warranty

Each instrument manufactured by Panametrics is warranted to be free from defects in material and workmanship. Liability under this warranty is limited to restoring the instrument to normal operation or replacing the instrument, at the sole discretion of Panametrics. Fuses and batteries are specifically excluded from any liability. This warranty is effective from the date of delivery to the original purchaser. If Panametrics determines that the equipment was defective, the warranty period is:

- One year from delivery for electronic or mechanical failures
- One year from delivery for sensor shelf life

If Panametrics determines that the equipment was damaged by misuse, improper installation, the use of unauthorized replacement parts, or operating conditions outside the guidelines specified by Panametrics, the repairs are not covered under this warranty.

The warranties set forth herein are exclusive and are in lieu of all other warranties whether statutory, express or implied (including warranties or merchantability and fitness for a particular purpose, and warranties arising from course of dealing or usage or trade).

Return Policy

If a Panametrics instrument malfunctions within the warranty period, the following procedure must be completed:

1. Notify Panametrics, giving full details of the problem, and provide the model number and serial number of the instrument. If the nature of the problem indicates the need for factory service, Panametrics will issue a RETURN AUTHORIZATION NUMBER (RAN), and shipping instructions for the return of the instrument to a service center will be provided.
2. If Panametrics instructs you to send your instrument to a service center, it must be shipped prepaid to the authorized repair station indicated in the shipping instructions.
3. Upon receipt, Panametrics will evaluate the instrument to determine the cause of the malfunction.

Then, one of the following courses of action will then be taken:

- If the damage is covered under the terms of the warranty, the instrument will be repaired at no cost to the owner and returned.
- If Panametrics determines that the damage is not covered under the terms of the warranty, or if the warranty has expired, an estimate for the cost of the repairs at standard rates will be provided. Upon receipt of the owner's approval to proceed, the instrument will be repaired and returned.

We,

Panametrics LLC
1100 Technology Park Drive
Billerica, MA 01821
U.S.A.

declare under our sole responsibility that the

TransPort® PT900 Ultrasonic Flow Meter

to which this declaration relates, is in conformity with the following standards:

- EN 61326-1: 2013, **Power supply:** Group 1, Class B, Table 1, Basic EM Environment
Flow meter: Group 1, Class A, Table A.1, Portable Test and measurement
- EN 61326-2-3:2013
- EN 301 489-1 V1.9.2
- EN 301 489-17 V2.2.1
- EN 300 328 V1.9.1
- EN 62479: 2010
- EN 61010-1: 2010
- EN 60529:1991+A1:2000+A2:2013 IP65
- EN 62321: 2013

following the provisions of Directives 2014/30/EU (EMC),
2014/53/EU (RED), 2014/35/EU (LVD) and 2011/65/EU (RoHS).

13th March 2017

Issued



Mr. Chris Frail
Engineering Manager
Panametrics LLC
Billerica, MA U.S.A.

[no content intended for this page]

Customer Support Centers

U.S.A.

The Boston Center
1100 Technology Park Drive
Billerica, MA 01821
U.S.A.

Tel: 800 833 9438 (toll-free)
978 437 1000

E-mail: panametricstechsupport@bakerhughes.com

Ireland

Sensing House
Shannon Free Zone East
Shannon, County Clare
Ireland

Tel: +353 61 61470200

E-mail: panametricstechsupport@bakerhughes.com

Copyright 2022 Baker Hughes company.

This material contains one or more registered trademarks of Baker Hughes Company and its subsidiaries in one or more countries. All third-party product and company names are trademarks of their respective holders.

BH033C11 EN D (09/2022)

Baker Hughes 