



pro.IQ moisture analyzer packaged solution

Features

Deliver an accurate moisture measurement with the Panametrics pro.IQ. The new moisture analyzer packaged solution simplifies the selection and installation of your moisture analyzer. Only a few simple steps; install the moisture transmitter, and connect your loop power and sample gas or liquid to the inlet fitting and you are ready to measure. Other benefits include:

- IP66 and NEMA 4X package
- The moisture transmitter, sample system and Zener barrier (if ATEX Zone 1 or Class I Div. 1 hazardous area option selected)
- Features the HygroPro[®] moisture transmitter
- Sample system provides isolation, filtration, pressure indication on gas systems and flow indication on both gas and liquid systems. Enclosure is available in 304SS and 316SS and has a clear door for viewing all readings. Optional heater is also available.

Applications

The standard pro.IQ package is designed for moisture measurements in hydrocarbon gas, liquid or inert gas application. It may be used in environments classified as safe or hazardous areas, where the process gas or liquid pressure is up to 200 psig (14 bar) in safe areas, 400 psig/27 bar (gas system) or 500 psig/34.5 bar (liquid system) in hazardous area. The system combines the Panametrics HygroPro[®] with over 50 years of sample system design experience, to deliver the moisture measurement you have come to trust.

Markets and applications served include:

- Natural gas
- Hydrocarbon gases
- Hydrocarbon liquids
- Petrochemical
- Metal heat treatment
- Industrial gas
- Power generation

Ordering configuration

pro.IQ is comprised of the following items:

- HygroPro^{II} moisture transmitter
- Sample system with configurable options for gas or liquid applications, general purpose or hazardous area, enclosure heater, enclosure material and process connection
- Zener barrier open ATEX Zone 1 or Class I Div. 1 Hazardous area option only)

Available options

pro.IQ Price Option A	Console
pro.IQ	Hydrocarbon gas/liquid sample system
pro.IQ Price Option B	Gas/Liquid
pro.IQ-B-0	Gas System
pro.IQ-B-1	Liquid System
pro.IQ Price Option C	Certification
pro.IQ-C-0	Safe Area / General Purpose
pro.IQ-C-1	Class I, Div. 1, Group A-D
pro.IQ-C-2	Class I, Div. 2, Group A-D
pro.IQ-C-3	ATEX/IECEx Zone 1 IIC
pro.IQ-C-4	ATEX/IECEx Zone 2 IIC
pro.IQ Price Option D	Heater
pro.IQ-D-0	Without Heater
pro.IQ-D-1	With Heater (80W)
pro.IQ Price Option E	Enclosure
pro.IQ-E-0	304SS Enclosure
pro.IQ-E-1	316SS Enclosure
pro.IQ Price Option F	Fittings
pro.IQ-F-(I)	Imperial Components - 1/4 inch
pro.IQ-F-(M)	Metric components - 6mm

Application parameters

General purpose configuration

- Sample gas or liquid pressure: 0 to 200 psig (14 bar)
- Recommended operating temperature range: 32°F to 122°F (0 to +50°C)

Hazardous area configuration

- Sample gas pressure: 0 to 400 psig (27 bar)
- Sample liquid pressure: 0 to 500 psig (34.5 bar)
- Recommended operating temperature range: 32°F to 140°F (0 to +60°C)

Common

- Moisture content: -166°F to 68°F (-110°C to 20°C) dew/frost point, non-condensing

HygroPro^{II} specifications

Dew point/frost point calibration ranges

Standard: -112°F to 50°F (-80°C to +10°C) with data from -166°F to +68°F (-110°C to +20°C)

Operating temperature

-4°F to 140°F (-20°C to 60°C*)

*Refer to pro.IQ specifications for overall system limits

Storage temperature

158°F (70°C) maximum

Warm-up time

Meets specified accuracy in three minutes

Calibrated accuracy @ 77°F (25°C)

- ±3.6°F (±2°C) above -148°F (-100°C)
- ±5.4°F (±3°C) below -148°F (-100°C)

Repeatability

- ±0.4°F (±0.2°C) above -148°F (-100°C)
- ±0.9°F (±0.5°C) below -148°F (-100°C)

Electrical

Power

- Voltage: 12 to 30 VDC (loop-powered, customer supplied)
- Output: 4 to 20 mA analog and HART digital
- Output resolution: 0.01 mA/12 bits
- Cable: 6 ft (2 m), standard includes molded weatherproof connector with flying leads to connect transmitter to sample system terminal block

Display

- 128 x 64 LED backlit LCD
- Display from one to three parameters and diagnostics

Mechanical

Sample connection

- 3/4-16 in (19 mm) straight male thread with o-ring

Operating pressure

5 µm Hg to 5,000 psig (345 bar*)

*Refer to pro.IQ specifications for overall system limits

Enclosure

Type 4X/IP67

Dimensions

- H x W x D: 7.80 x 4.00 x 2.57 (198 x 102 x 65 mm)
- Weight: 2.75 lbs. (1250 g)

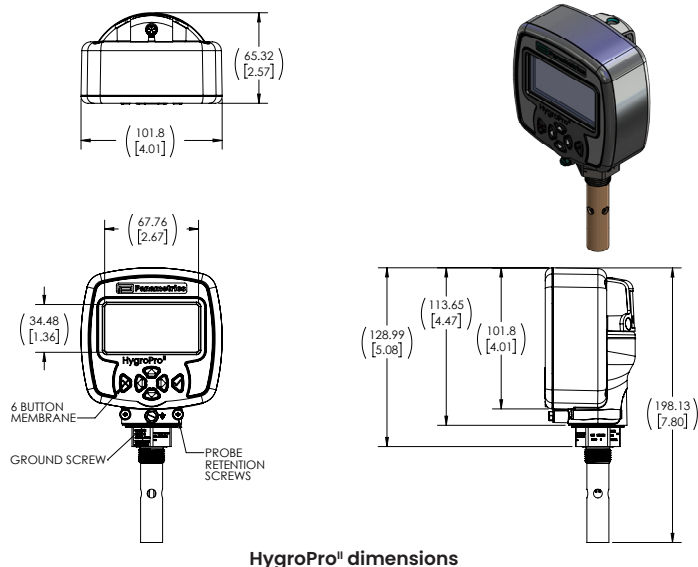

European compliance

Complies with EMC Directive 2004/108/EC and PED 97/23/EC for DN<25

Hazardous area certification

- US/Canada: Class I, Division 1, Groups A, B, C and D; T4
Class II, III Division 1, Groups E, F and G; T4 (US Only)
Class I, Zone 0, AEx ia IIC T4 Ga
- US/Canada: Class I, Division 2, Groups A, B, C and D; T4
Class II, III Division 2, Groups F and G; T4
Class I, Zone 2, AEx ic IIC T4 Gc (US Only)
- ATEX/IECEx: Ex ia IIC T4 Ga; Ex ic IIC T4 Gc

Moisture sensor

Sensor type

Thin-film aluminum oxide moisture sensor

Calibration

Each sensor is individually computer-calibrated against known moisture concentrations, traceable to national standards.

Calibration interval

Sensor recalibration by Panametrics is recommended every six to twelve months depending on application.

Flow rate

Gases: Static to 100 m/s linear velocity at 1 atm

Built-in temperature sensor

Type

NTC thermistor

Operating range

-22°F to 158°F (-30°C to 70°C)

Accuracy

±0.9°F (±0.5°C) overall

Response time (maximum)

One second in well stirred oil or 10 seconds in still air for a 63% step change in increasing or decreasing temperature

Built-in pressure sensor

Type

Solid state/piezoresistive

Available ranges

- 30 to 300 psig (3 to 21 bar)
- 50 to 500 psig (4 to 35 bar)

Accuracy

±1% of full scale (FS)

Pressure rating

Three times the span of the specified range to a maximum of 7500 psig (518 bar*)

*Refer to pro.iQ specifications for overall system limits

Start-up procedure

- Insert moisture transmitter into the sample cell and connect earth to ground connection of the transmitter.
- Follow HygroPro[®] manual wiring instructions to connect power, pay special attention to zener barrier installation and wiring if in hazardous area.

Gas application

- For gas applications with potential light liquid contaminant, install the fibre filter element (supplied loose) in the filter housing, removing the particulate filter element already installed.
- Start with the inlet valve, the drain valve and the sample outlet valve fully closed.
- For measurement at process pressure, slowly open the inlet valve until fully open; then crack the sample outlet valve to get flow on mid-range of the flowmeter scale.
- For measurement at atmospheric pressure, fully open the sample outlet valve; then crack the inlet needle valve to get flow on scale.
- For applications with potential light liquid contaminant crack the drain needle valve to ensure continuous removal of any liquid mists from the sample gas.

*Use appropriate filter element supplied

Liquid application

- Start with the inlet valve, the drain valve and the sample outlet valve fully closed.
- Slowly open the inlet valve until fully open; then crack the sample outlet valve to get flow on mid-range of the flowmeter scale.

Shut-down procedure

- Slowly close the inlet needle valve.
- Slowly open the drain needle valve until the pressure on the pressure gauge (or for liquid systems, the pressure reading on the HygroPro[®] display) is 0 psig.
- Remove the moisture transmitter.

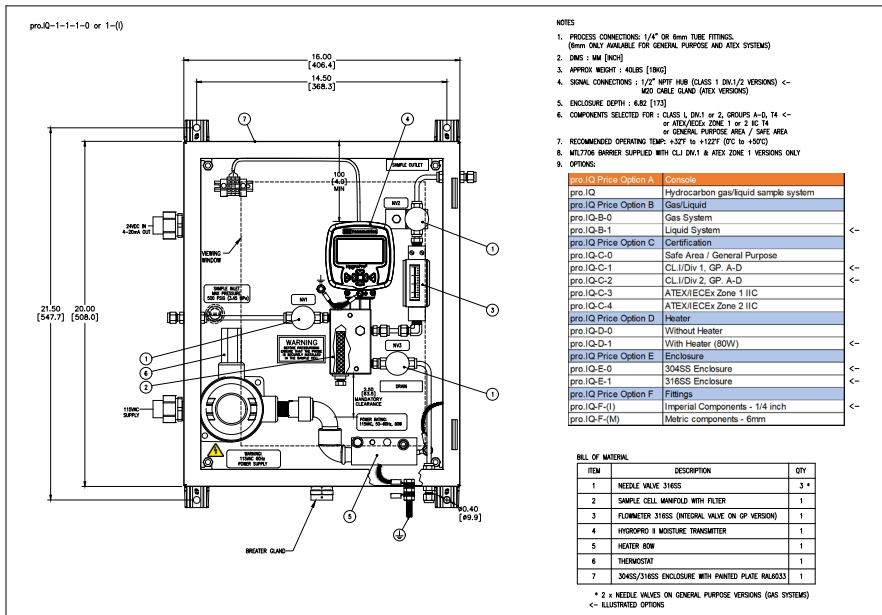
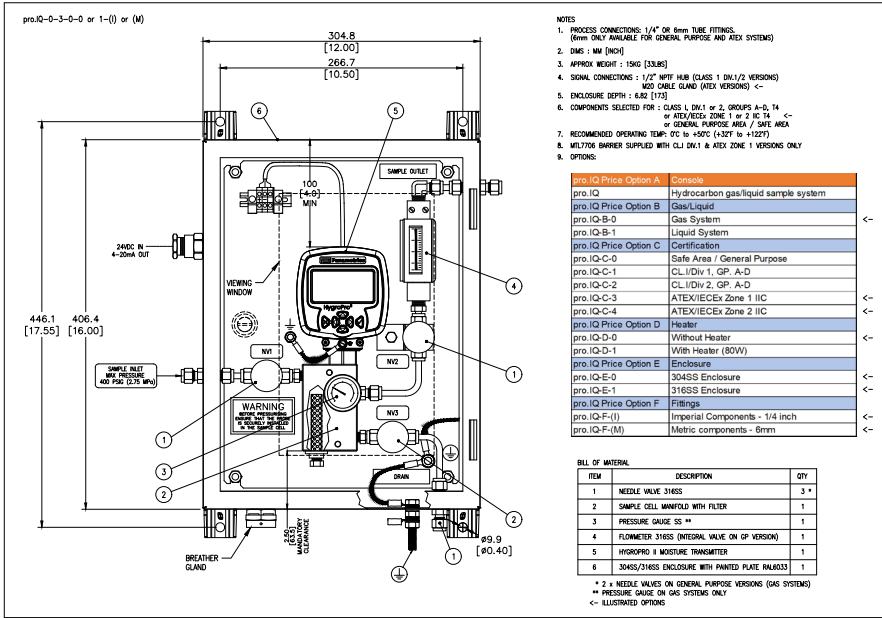

Panametrics, a Baker Hughes business, provides solutions in the toughest applications and environments for moisture, oxygen, liquid and gas flow measurement. Experts in flare management, Panametrics technology also reduces flare emissions and optimizes performance.

With a reach that extends across the globe, Panametrics' critical measurement solutions and flare emissions management are enabling customers to drive efficiency and achieve carbon reduction targets across critical industries including: Oil & Gas; Energy; Healthcare; Water and Wastewater; Chemical Processing; Food & Beverage and many others.

Join the conversation and follow us on LinkedIn
[linkedin.com/company/panametricscompany](https://www.linkedin.com/company/panametricscompany)