

Operating Instructions

Proline t-mass F 500

Modbus RS485

Thermal mass flowmeter

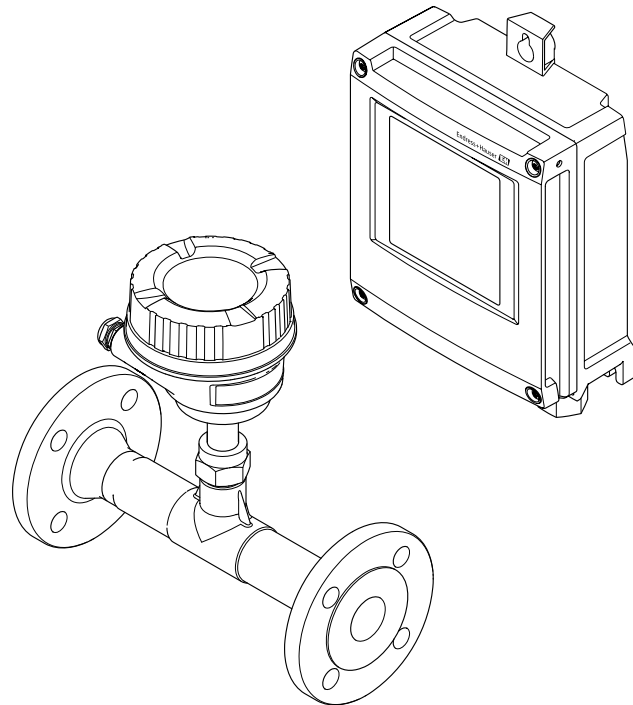

- Make sure the document is stored in a safe place such that it is always available when working on or with the device.
- To avoid danger to individuals or the facility, read the "Basic safety instructions" section carefully, as well as all other safety instructions in the document that are specific to working procedures.
- The manufacturer reserves the right to modify technical data without prior notice. Your Endress+Hauser Sales Center will supply you with current information and updates to these instructions.

Table of contents

1	About this document	6		
1.1	Document function	6		
1.2	Symbols	6		
1.2.1	Safety symbols	6		
1.2.2	Electrical symbols	6		
1.2.3	Communication symbols	6		
1.2.4	Tool symbols	7		
1.2.5	Symbols for certain types of information	7		
1.2.6	Symbols in graphics	7		
1.3	Documentation	8		
1.3.1	Standard documentation	8		
1.3.2	Supplementary device-dependent documentation	8		
1.4	Registered trademarks	9		
2	Safety instructions	10		
2.1	Requirements for the personnel	10		
2.2	Designated use	10		
2.3	Workplace safety	11		
2.4	Operational safety	11		
2.5	Product safety	12		
2.6	IT security	12		
2.7	Device-specific IT security	12		
2.7.1	Protecting access via hardware write protection	12		
2.7.2	Protecting access via a password	13		
2.7.3	Access via Web server	13		
2.7.4	Access via service interface (CDI- RJ45)	14		
3	Product description	15		
3.1	Product design	15		
3.1.1	Proline 500 – digital	15		
4	Incoming acceptance and product identification	16		
4.1	Incoming acceptance	16		
4.2	Product identification	16		
4.2.1	Transmitter nameplate	17		
4.2.2	Sensor nameplate	18		
4.2.3	Symbols on measuring device	19		
4.3	Storage and transport	19		
4.3.1	Storage conditions	19		
4.3.2	Transporting the product	19		
4.3.3	Packaging disposal	20		
5	Installation	21		
5.1	Installation conditions	21		
5.1.1	Mounting position	21		
5.1.2	Environment and process requirements	26		
5.1.3	Special mounting instructions	27		
5.2	Mounting the measuring device	28		
5.2.1	Required tool	28		
5.2.2	Preparing the measuring device	28		
5.2.3	Mounting the measuring device	28		
5.2.4	Mounting the transmitter housing: Proline 500 – digital	29		
5.3	Post-installation check	30		
6	Electrical connection	32		
6.1	Electrical safety	32		
6.2	Connection conditions	32		
6.2.1	Required tools	32		
6.2.2	Requirements for connecting cable	32		
6.2.3	Terminal assignment	36		
6.2.4	Shielding and grounding	37		
6.2.5	Preparing the measuring device	37		
6.3	Connecting the measuring device: Proline 500 - digital	38		
6.3.1	Connecting the connecting cable	38		
6.3.2	Connecting the signal cable and the supply voltage cable	41		
6.4	Ensuring potential equalization	42		
6.4.1	Requirements	42		
6.5	Special connection instructions	43		
6.5.1	Connection examples	43		
6.6	Hardware settings	45		
6.6.1	Setting the device address	45		
6.6.2	Enabling the terminating resistor	46		
6.7	Ensuring the degree of protection	47		
6.7.1	Degree of protection IP68, Type 6P enclosure, with "Cust-potted" option	48		
6.8	Post-connection check	48		
7	Operation options	49		
7.1	Overview of operation options	49		
7.2	Structure and function of the operating menu	50		
7.2.1	Structure of the operating menu	50		
7.2.2	Operating philosophy	51		
7.3	Access to the operating menu via the local display	52		
7.3.1	Operational display	52		
7.3.2	Navigation view	53		
7.3.3	Editing view	55		
7.3.4	Operating elements	57		
7.3.5	Opening the context menu	58		
7.3.6	Navigating and selecting from list	59		
7.3.7	Calling the parameter directly	59		
7.3.8	Calling up help text	60		
7.3.9	Changing the parameters	60		
7.3.10	User roles and related access authorization	61		

7.3.11	Disabling write protection via access code	61	9.5.4	WLAN configuration	112
7.3.12	Enabling and disabling the keypad lock	62	9.5.5	Configuration management	114
7.4	Access to the operating menu via the Web browser	62	9.5.6	Using parameters for device administration	116
7.4.1	Function range	62	9.5.7	In-situ adjustment	117
7.4.2	Prerequisites	63	9.6	Configuration management	124
7.4.3	Establishing a connection	64	9.6.1	Function scope of the "Configuration management" parameter	125
7.4.4	Logging on	66	9.7	Simulation	125
7.4.5	User interface	67	9.8	Protecting settings from unauthorized access	127
7.4.6	Disabling the Web server	68	9.8.1	Write protection via access code ...	127
7.4.7	Logging out	68	9.8.2	Write protection via write protection switch	129
7.5	Access to the operating menu via the operating tool	69	10	Operation	131
7.5.1	Connecting the operating tool	69	10.1	Reading the device locking status	131
7.5.2	FieldCare	71	10.2	Adjusting the operating language	131
7.5.3	DeviceCare	72	10.3	Configuring the display	131
8	System integration	73	10.4	Reading measured values	131
8.1	Overview of device description files	73	10.4.1	Process variables	132
8.1.1	Current version data for the device ...	73	10.4.2	System values	133
8.1.2	Operating tools	73	10.4.3	"Totalizer" submenu	133
8.2	Compatibility with earlier model	73	10.4.4	"Input values" submenu	134
8.3	Modbus RS485 information	74	10.4.5	Output values	135
8.3.1	Function codes	74	10.5	Adapting the measuring device to the process conditions	137
8.3.2	Register information	75	10.6	Performing a totalizer reset	137
8.3.3	Response time	75	10.6.1	Function scope of the "Control Totalizer" parameter	138
8.3.4	Data types	75	10.6.2	Function scope of the "Reset all totalizers" parameter	138
8.3.5	Byte transmission sequence	76	10.7	Showing data logging	138
8.3.6	Modbus data map	76	11	Diagnostics and troubleshooting ..	142
9	Commissioning	79	11.1	General troubleshooting	142
9.1	Function check	79	11.2	Diagnostic information via light emitting diodes	144
9.2	Switching on the measuring device	79	11.2.1	Transmitter	144
9.3	Setting the operating language	79	11.2.2	Sensor connection housing	146
9.4	Configuring the measuring device	80	11.3	Diagnostic information on local display	147
9.4.1	Defining the tag name	81	11.3.1	Diagnostic message	147
9.4.2	Configuring the measurement mode	81	11.3.2	Calling up remedial measures	149
9.4.3	Configuring reference conditions	85	11.4	Diagnostic information in the Web browser ..	149
9.4.4	Sensor adjustment	87	11.4.1	Diagnostic options	149
9.4.5	Configuring the status input	87	11.4.2	Calling up remedy information	150
9.4.6	Setting the system units	88	11.5	Diagnostic information in FieldCare or DeviceCare	150
9.4.7	Displaying the I/O configuration	90	11.5.1	Diagnostic options	150
9.4.8	Configuring the current input	91	11.5.2	Calling up remedy information	151
9.4.9	Configuring the current output	92	11.6	Diagnostic information via communication interface	152
9.4.10	Configuring the pulse/frequency/switch output	95	11.6.1	Reading out diagnostic information	152
9.4.11	Configuring the relay output	101	11.6.2	Configuring error response mode ...	152
9.4.12	Configuring the local display	102	11.7	Adapting the diagnostic information	152
9.4.13	Configuring the low flow cut off	106	11.7.1	Adapting the diagnostic behavior ...	152
9.5	Advanced settings	107	11.8	Overview of diagnostic information	153
9.5.1	Using the parameter to enter the access code	107	11.9	Pending diagnostic events	156
9.5.2	Configuring the totalizer	107			
9.5.3	Carrying out additional display configurations	109			

11.10	Diagnostic list	157
11.11	Event logbook	157
11.11.1	Reading out the event logbook	157
11.11.2	Filtering the event logbook	158
11.11.3	Overview of information events	158
11.12	Resetting the measuring device	160
11.12.1	Function scope of the "Device reset" parameter	160
11.13	Device information	160
11.14	Firmware history	161
11.15	Device history and compatibility	162
12	Maintenance	163
12.1	Maintenance tasks	163
12.1.1	Exterior cleaning	163
12.1.2	Sensing element cleaning	163
12.1.3	Recalibration	164
12.2	Measuring and test equipment	164
12.3	Endress+Hauser services	164
13	Repair	165
13.1	General notes	165
13.1.1	Repair and conversion concept	165
13.1.2	Notes for repair and conversion	165
13.2	Spare parts	165
13.3	Endress+Hauser services	165
13.4	Return	165
13.5	Disposal	166
13.5.1	Removing the measuring device	166
13.5.2	Disposing of the measuring device	166
14	Accessories	167
14.1	Device-specific accessories	167
14.1.1	For the transmitter	167
14.2	Communication-specific accessories	168
14.3	Service-specific accessories	169
14.4	System components	169
15	Technical data	170
15.1	Application	170
15.2	Function and system design	170
15.3	Input	171
15.4	Output	176
15.5	Power supply	180
15.6	Performance characteristics	182
15.7	Installation	183
15.8	Environment	183
15.9	Process	186
15.10	Mechanical construction	187
15.11	Human interface	190
15.12	Certificates and approvals	194
15.13	Application packages	197
15.14	Accessories	197
15.15	Supplementary documentation	198
Index	200	

1 About this document

1.1 Document function

These Operating Instructions contain all the information that is required in various phases of the life cycle of the device: from product identification, incoming acceptance and storage, to mounting, connection, operation and commissioning through to troubleshooting, maintenance and disposal.

1.2 Symbols

1.2.1 Safety symbols

DANGER

This symbol alerts you to a dangerous situation. Failure to avoid this situation will result in serious or fatal injury.

WARNING

This symbol alerts you to a dangerous situation. Failure to avoid this situation can result in serious or fatal injury.





CAUTION

This symbol alerts you to a dangerous situation. Failure to avoid this situation can result in minor or medium injury.



NOTICE



This symbol contains information on procedures and other facts which do not result in personal injury.

1.2.2 Electrical symbols



Symbol	Meaning
	Direct current
	Alternating current
	Direct current and alternating current
	Ground connection A grounded terminal which, as far as the operator is concerned, is grounded via a grounding system.
	Protective Earth (PE) A terminal which must be connected to ground prior to establishing any other connections. The ground terminals are situated inside and outside the device: <ul style="list-style-type: none"> ▪ Inner ground terminal: Connects the protective earth to the mains supply. ▪ Outer ground terminal: Connects the device to the plant grounding system.

1.2.3 Communication symbols













Symbol	Meaning
	Wireless Local Area Network (WLAN) Communication via a wireless, local network.
	LED Light emitting diode is off.

Symbol	Meaning
	LED Light emitting diode is on.
	LED Light emitting diode is flashing.





1.2.4 Tool symbols



Symbol	Meaning
	Torx screwdriver
	Phillips head screwdriver
	Open-ended wrench

1.2.5 Symbols for certain types of information

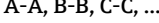
Symbol	Meaning
	Permitted Procedures, processes or actions that are permitted.
	Preferred Procedures, processes or actions that are preferred.
	Forbidden Procedures, processes or actions that are forbidden.
	Tip Indicates additional information.
	Reference to documentation.
	Reference to page.
	Reference to graphic.
	Notice or individual step to be observed.
	Series of steps.
	Result of a step.
	Help in the event of a problem.
	Visual inspection.

1.2.6 Symbols in graphics

Symbol	Meaning
	Item numbers
	Series of steps
	Views
	Sections
	Hazardous area

Symbol	Meaning
	Safe area (non-hazardous area)
	Flow direction

1.3 Documentation

 For an overview of the scope of the associated Technical Documentation, refer to the following:

- *W@M Device Viewer* (www.endress.com/deviceviewer): Enter the serial number from nameplate
- *Endress+Hauser Operations App*: Enter the serial number from the nameplate or scan the 2D matrix code (QR code) on the nameplate

 Detailed list of the individual documents along with the documentation code

1.3.1 Standard documentation

Document type	Purpose and content of the document
Technical Information	Planning aid for your device The document contains all the technical data on the device and provides an overview of the accessories and other products that can be ordered for the device.
Sensor Brief Operating Instructions	Guides you quickly to the 1st measured value - Part 1 The Sensor Brief Operating Instructions are aimed at specialists with responsibility for installing the measuring device. <ul style="list-style-type: none"> ▪ Incoming acceptance and product identification ▪ Storage and transport ▪ Installation
Transmitter Brief Operating Instructions	Guides you quickly to the 1st measured value - Part 2 The Transmitter Brief Operating Instructions are aimed at specialists with responsibility for commissioning, configuring and parameterizing the measuring device (until the first measured value). <ul style="list-style-type: none"> ▪ Product description ▪ Installation ▪ Electrical connection ▪ Operation options ▪ System integration ▪ Commissioning ▪ Diagnostic information
Description of Device Parameters	Reference for your parameters The document provides a detailed explanation of each individual parameter in the Expert operating menu. The description is aimed at those who work with the device over the entire life cycle and perform specific configurations. The document provides Modbus-specific information for each individual parameter in the Expert operating menu.

1.3.2 Supplementary device-dependent documentation

Additional documents are supplied depending on the device version ordered: Always comply strictly with the instructions in the supplementary documentation. The supplementary documentation is an integral part of the device documentation.

1.4 Registered trademarks

Modbus®

Registered trademark of SCHNEIDER AUTOMATION, INC.

2 Safety instructions

2.1 Requirements for the personnel

The personnel for installation, commissioning, diagnostics and maintenance must fulfill the following requirements:

- ▶ Trained, qualified specialists must have a relevant qualification for this specific function and task.
- ▶ Are authorized by the plant owner/operator.
- ▶ Are familiar with federal/national regulations.
- ▶ Before starting work, read and understand the instructions in the manual and supplementary documentation as well as the certificates (depending on the application).
- ▶ Follow instructions and comply with basic conditions.

The operating personnel must fulfill the following requirements:

- ▶ Are instructed and authorized according to the requirements of the task by the facility's owner-operator.
- ▶ Follow the instructions in this manual.

2.2 Designated use

Application and media

The measuring device described in this manual is intended only for the flow measurement of gases.

Depending on the version ordered, the measuring device can also measure potentially explosive, flammable, poisonous and oxidizing media.

Measuring devices for use in hazardous areas, or where there is an increased risk due to process pressure, are labeled accordingly on the nameplate.

To ensure that the measuring device remains in proper condition for the operation time:

- ▶ Keep within the specified pressure and temperature range.
- ▶ Only use the measuring device in full compliance with the data on the nameplate and the general conditions listed in the Operating Instructions and supplementary documentation.
- ▶ Based on the nameplate, check whether the ordered device is permitted for the intended use in the hazardous area (e.g. explosion protection, pressure vessel safety).
- ▶ Use the measuring device only for media to which the process-wetted materials are sufficiently resistant.
- ▶ If the ambient temperature of the measuring device is outside the atmospheric temperature, it is absolutely essential to comply with the relevant basic conditions as specified in the device documentation →  8.
- ▶ Protect the measuring device permanently against corrosion from environmental influences.

Incorrect use

Non-designated use can compromise safety. The manufacturer is not liable for damage caused by improper or non-designated use.

WARNING

Danger of breakage due to corrosive or abrasive fluids and ambient conditions!

- ▶ Verify the compatibility of the process fluid with the sensor material.
- ▶ Ensure the resistance of all fluid-wetted materials in the process.
- ▶ Keep within the specified pressure and temperature range.

NOTICE**Verification for borderline cases:**

- ▶ For special fluids and fluids for cleaning, Endress+Hauser is glad to provide assistance in verifying the corrosion resistance of fluid-wetted materials, but does not accept any warranty or liability as minute changes in the temperature, concentration or level of contamination in the process can alter the corrosion resistance properties.

⚠ WARNING**Risk of injury if the process connection and gland of the sensing element are opened under pressure.**

- ▶ The process connection and sensor gland should be opened only when in an unpressurized state.

NOTICE**Penetration of dust and moisture when the transmitter housing is opened.**

- ▶ Only open the transmitter housing briefly, ensuring that no dust or moisture enters the housing.

Residual risks**⚠ WARNING****The electronics and the medium may cause the surfaces to heat up. This presents a burn hazard!**

- ▶ For elevated fluid temperatures, ensure protection against contact to prevent burns.

2.3 Workplace safety

For work on and with the device:

- ▶ Wear the required personal protective equipment according to federal/national regulations.

For welding work on the piping:

- ▶ Do not ground the welding unit via the measuring device.

If working on and with the device with wet hands:

- ▶ Due to the increased risk of electric shock, gloves must be worn.

2.4 Operational safety

Risk of injury.

- ▶ Operate the device in proper technical condition and fail-safe condition only.
- ▶ The operator is responsible for interference-free operation of the device.

Conversions to the device

Unauthorized modifications to the device are not permitted and can lead to unforeseeable dangers.

- ▶ If, despite this, modifications are required, consult with Endress+Hauser.

Repair

To ensure continued operational safety and reliability,

- ▶ Carry out repairs on the device only if they are expressly permitted.
- ▶ Observe federal/national regulations pertaining to repair of an electrical device.
- ▶ Use original spare parts and accessories from Endress+Hauser only.

2.5 Product safety

This measuring device is designed in accordance with good engineering practice to meet state-of-the-art safety requirements, has been tested, and left the factory in a condition in which it is safe to operate.

It meets general safety standards and legal requirements. It also complies with the EU directives listed in the device-specific EU Declaration of Conformity. Endress+Hauser confirms this by affixing the CE mark to the device.





2.6 IT security

Our warranty is valid only if the device is installed and used as described in the Operating Instructions. The device is equipped with security mechanisms to protect it against any inadvertent changes to the settings.

IT security measures, which provide additional protection for the device and associated data transfer, must be implemented by the operators themselves in line with their security standards.

2.7 Device-specific IT security

The device offers a range of specific functions to support protective measures on the operator's side. These functions can be configured by the user and guarantee greater in-operation safety if used correctly. An overview of the most important functions is provided in the following section.

Function/interface	Factory setting	Recommendation
Write protection via hardware write protection switch →  12	Not enabled.	On an individual basis following risk assessment.
Access code (also applies for Web server login or FieldCare connection) →  13	Not enabled (0000).	Assign a customized access code during commissioning.
WLAN (order option in display module)	Enabled.	On an individual basis following risk assessment.
WLAN security mode	Enabled (WPA2-PSK)	Do not change.
WLAN passphrase (password) →  13	Serial number	Assign an individual WLAN passphrase during commissioning.
WLAN mode	Access Point	On an individual basis following risk assessment.
Web server →  13	Enabled.	On an individual basis following risk assessment.
CDI-RJ45 service interface →  14	–	On an individual basis following risk assessment.

2.7.1 Protecting access via hardware write protection

Write access to the device parameters via the local display, Web browser or operating tool (e.g. FieldCare, DeviceCare) can be disabled via a write protection switch (DIP switch on the motherboard). When hardware write protection is enabled, only read access to the parameters is possible.

Hardware write protection is disabled when the device is delivered →  129.

2.7.2 Protecting access via a password

Different passwords are available to protect write access to the device parameters or access to the device via the WLAN interface.

- **User-specific access code**
Protect write access to the device parameters via the local display, Web browser or operating tool (e.g. FieldCare, DeviceCare). Access authorization is clearly regulated through the use of a user-specific access code.
- **WLAN passphrase**
The network key protects a connection between an operating unit (e.g. notebook or tablet) and the device via the WLAN interface which can be ordered as an option.
- **Infrastructure mode**
When the device is operated in infrastructure mode, the WLAN passphrase corresponds to the WLAN passphrase configured on the operator side.

User-specific access code

Write access to the device parameters via the local display, Web browser or operating tool (e.g. FieldCare, DeviceCare) can be protected by the modifiable, user-specific access code (→  127).

When the device is delivered, the device does not have an access code and is equivalent to 0000 (open).

WLAN passphrase: Operation as WLAN access point

A connection between an operating unit (e.g. notebook or tablet) and the device via the WLAN interface (→  70), which can be ordered as an optional extra, is protected by the network key. The WLAN authentication of the network key complies with the IEEE 802.11 standard.

When the device is delivered, the network key is pre-defined depending on the device. It can be changed via the **WLAN settings** submenu in the **WLAN passphrase** parameter (→  114).

Infrastructure mode

A connection between the device and WLAN access point is protected by means of an SSID and passphrase on the system side. Please contact the relevant system administrator for access.

General notes on the use of passwords

- The access code and network key supplied with the device should be changed during commissioning.
- Follow the general rules for generating a secure password when defining and managing the access code or network key.
- The user is responsible for the management and careful handling of the access code and network key.
- For information on configuring the access code or on what to do if you lose the password, see the "Write protection via access code" section →  127

2.7.3 Access via Web server

The device can be operated and configured via a Web browser with the integrated Web server (→  62). The connection is via the service interface (CDI-RJ45) or the WLAN interface.

The Web server is enabled when the device is delivered. The Web server can be disabled if necessary (e.g. after commissioning) via the **Web server functionality** parameter.

The device and status information can be hidden on the login page. This prevents unauthorized access to the information.



For detailed information on device parameters, see:
The "Description of Device Parameters" document .

2.7.4 Access via service interface (CDI-RJ45)

The device can be connected to a network via the service interface (CDI-RJ45). Device-specific functions guarantee the secure operation of the device in a network.

The use of relevant industrial standards and guidelines that have been defined by national and international safety committees, such as IEC/ISA62443 or the IEEE, is recommended. This includes organizational security measures such as the assignment of access authorization as well as technical measures such as network segmentation.

3 Product description

The measuring system consists of a transmitter and a sensor. The transmitter and sensor are mounted in physically separate locations. They are interconnected by connecting cables.

3.1 Product design

3.1.1 Proline 500 – digital

Signal transmission: digital

Order code for "Integrated ISEM electronics", option **A** "Sensor"

For use in applications not required to meet special requirements due to ambient or operating conditions.

As the electronics are located in the sensor, the device is ideal:
For simple transmitter replacement.

- A standard cable can be used as the connecting cable.
- Not sensitive to external EMC interference.

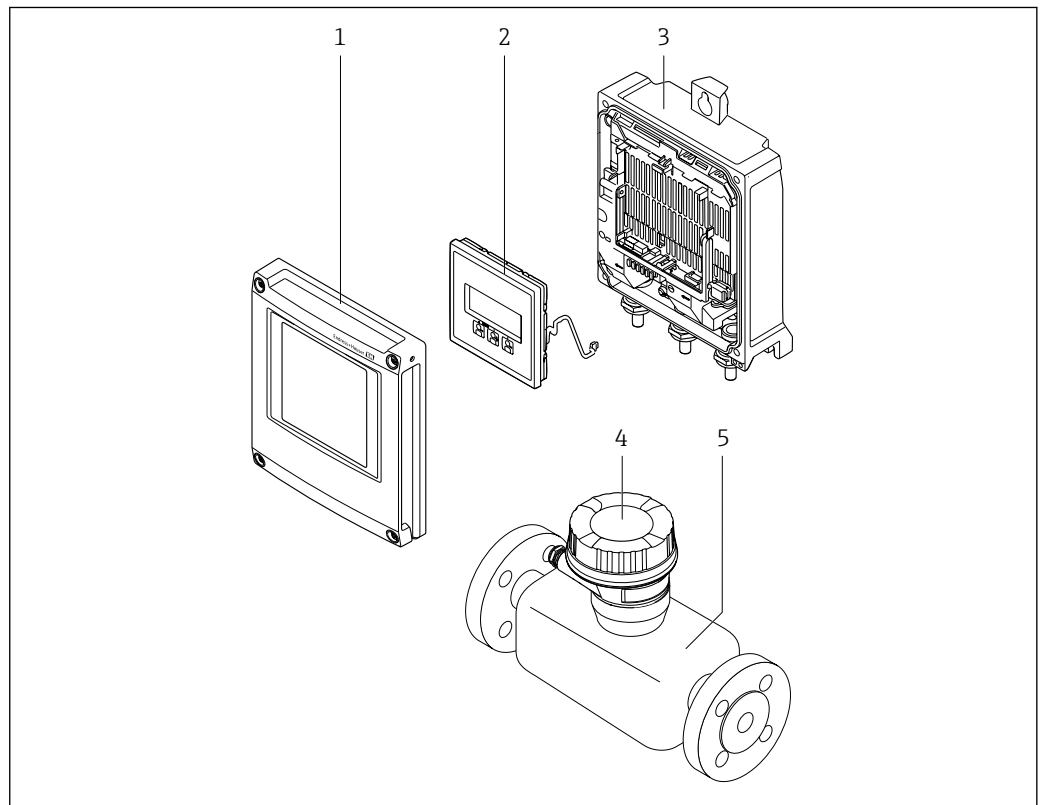

A0029593

1 Important components of a measuring device

- 1 Electronics compartment cover
- 2 Display module
- 3 Transmitter housing
- 4 Sensor connection housing with integrated ISEM electronics: connecting cable connection
- 5 Sensor

4 Incoming acceptance and product identification

4.1 Incoming acceptance

Are the order codes on the delivery note (1) and the product sticker (2) identical?

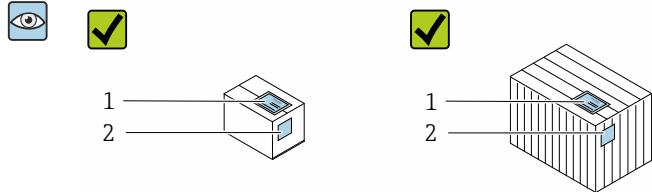

Are the goods undamaged?

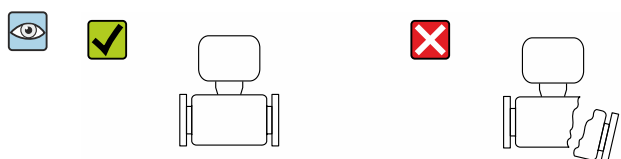

Do the nameplate data match the ordering information on the delivery note?

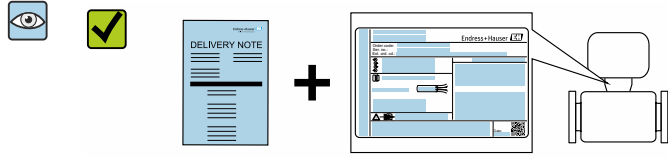

Is the envelope present with accompanying documents?

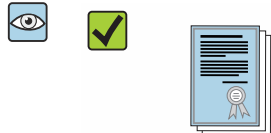

- i** ■ If one of the conditions is not satisfied, contact your Endress+Hauser Sales Center.
- Depending on the device version, the CD-ROM might not be part of the delivery! The Technical Documentation is available via the Internet or via the *Endress+Hauser Operations App*, see the "Product identification" section →  17.

4.2 Product identification

The following options are available for identification of the device:

- Nameplate specifications
- Order code with breakdown of the device features on the delivery note
- Enter serial numbers from nameplates in the *W@M Device Viewer* (www.endress.com/deviceviewer): All information about the device is displayed.
- Enter the serial number from nameplates in the *Endress+Hauser Operations App* or scan the 2-D matrix code (QR code) on the nameplate using the *Endress+Hauser Operations App*: All information about the device is displayed.

For an overview of the scope of the associated Technical Documentation, refer to the following:

- The "Additional standard documentation on the device" → 8 and "Supplementary device-dependent documentation" → 8 sections
- The *W@M Device Viewer*: enter the serial number from the nameplate (www.endress.com/deviceviewer)
- The *Endress+Hauser Operations App*: Enter the serial number from the nameplate or scan the 2-D matrix code (QR code) on the nameplate.

4.2.1 Transmitter nameplate

Proline 500 – digital

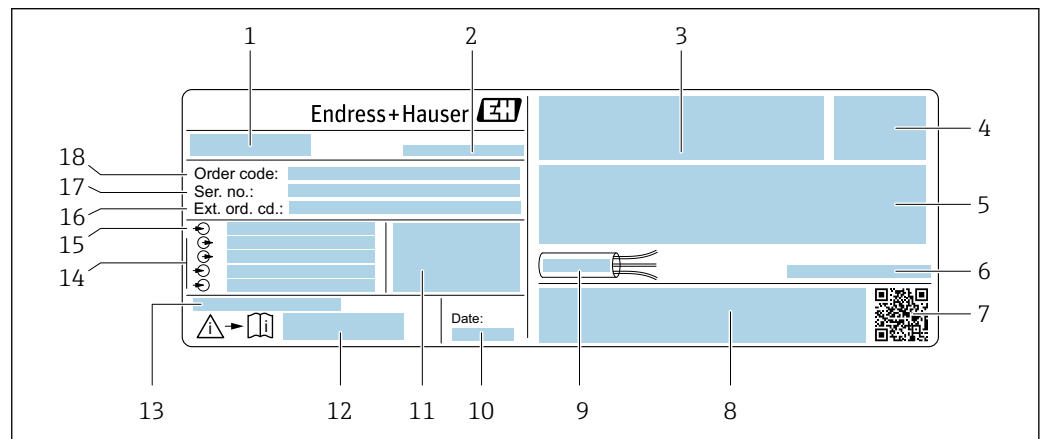

A0029194

2 Example of a transmitter nameplate

- 1 Name of the transmitter
- 2 Manufacturing location
- 3 Space for approvals: use in hazardous areas
- 4 Degree of protection
- 5 Electrical connection data: available inputs and outputs
- 6 Permitted ambient temperature (T_a)
- 7 2-D matrix code
- 8 Space for approvals and certificates: e.g. CE mark, C-Tick
- 9 Permitted temperature range for cable
- 10 Manufacturing date: year-month
- 11 Firmware version (FW) and device revision (Dev.Rev.) from the factory
- 12 Document number of safety-related supplementary documentation
- 13 Space for additional information in the case of special products
- 14 Available inputs and outputs, supply voltage
- 15 Electrical connection data: supply voltage
- 16 Extended order code (ext. ord. cd.)
- 17 Serial number (ser. no.)
- 18 Order code

4.2.2 Sensor nameplate

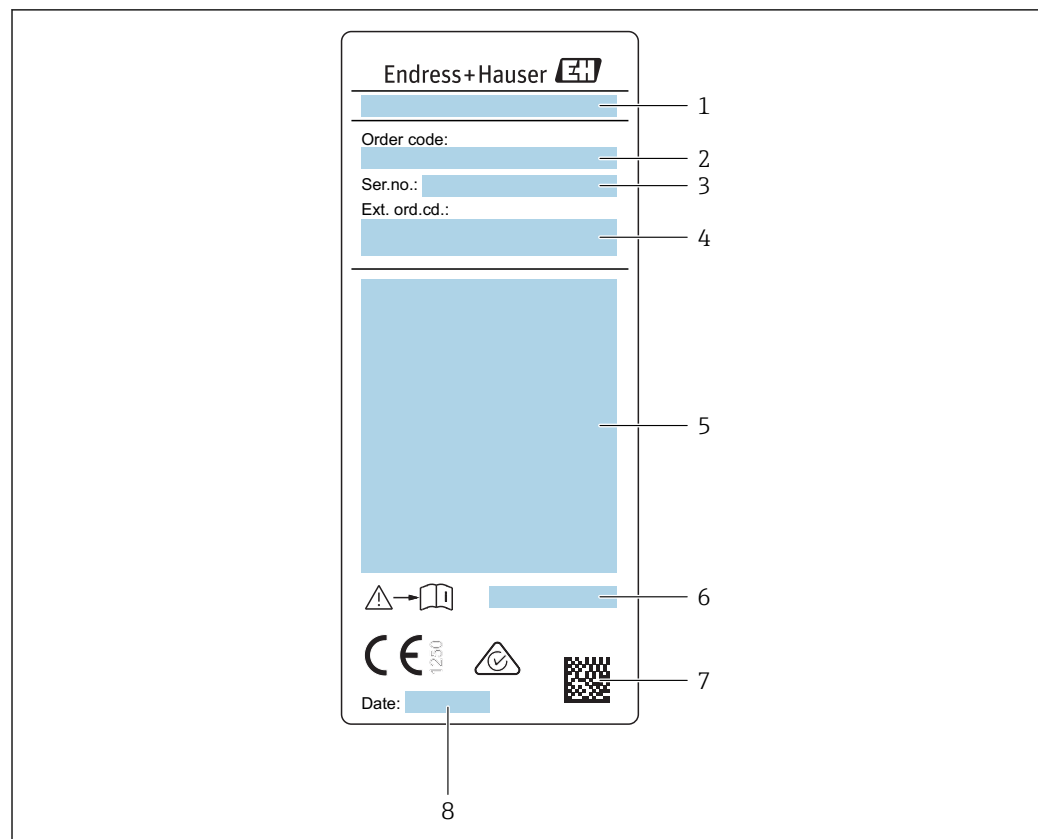

A0041923

 3 Example of sensor nameplate

- 1 Name of the sensor
- 2 Order code
- 3 Serial number (ser. no.)
- 4 Extended order code (ext. ord. cd.)
- 5 Flow; nominal diameter of sensor; pressure rating; nominal pressure; system pressure; medium temperature range; permitted ambient temperature range (T_a); explosion protection approval information, Pressure Equipment Directive and degree of protection
- 6 Document number of safety-related supplementary documentation →  198
- 7 2-D matrix code
- 8 Manufacturing date: year-month



Order code

The measuring device is reordered using the order code.

Extended order code

- The device type (product root) and basic specifications (mandatory features) are always listed.
- Of the optional specifications (optional features), only the safety and approval-related specifications are listed (e.g. LA). If other optional specifications are also ordered, these are indicated collectively using the # placeholder symbol (e.g. #LA#).
- If the ordered optional specifications do not include any safety and approval-related specifications, they are indicated by the + placeholder symbol (e.g. XXXXXX-ABCDE +).

4.2.3 Symbols on measuring device

Symbol	Meaning
	WARNING! This symbol alerts you to a dangerous situation. Failure to avoid this situation can result in serious or fatal injury.
	Reference to documentation Refers to the corresponding device documentation.
	Protective ground connection A terminal which must be connected to ground prior to establishing any other connections.

4.3 Storage and transport

4.3.1 Storage conditions

Observe the following notes for storage:

- ▶ Store in the original packaging to ensure protection from shock.
- ▶ Do not remove protective covers or protective caps installed on process connections. They prevent mechanical damage to the sealing surfaces and contamination in the measuring tube.
- ▶ Protect from direct sunlight to avoid unacceptably high surface temperatures.
- ▶ Select a storage location where moisture cannot collect in the measuring device as fungus and bacteria infestation can damage the liner.
- ▶ Store in a dry and dust-free place.
- ▶ Do not store outdoors.

Storage temperature →  184

4.3.2 Transporting the product

Transport the measuring device to the measuring point in the original packaging.

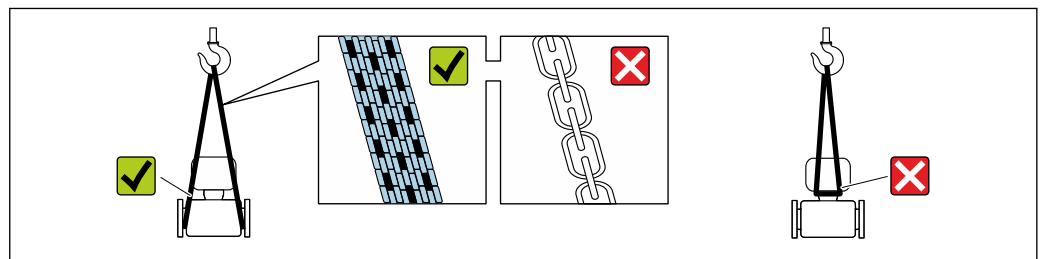

A0029252

-  Do not remove protective covers or caps installed on process connections. They prevent mechanical damage to the sealing surfaces and contamination in the measuring tube.

Measuring devices without lifting lugs

WARNING

Center of gravity of the measuring device is higher than the suspension points of the webbing slings.

Risk of injury if the measuring device slips.

- ▶ Secure the measuring device against slipping or turning.
- ▶ Observe the weight specified on the packaging (stick-on label).

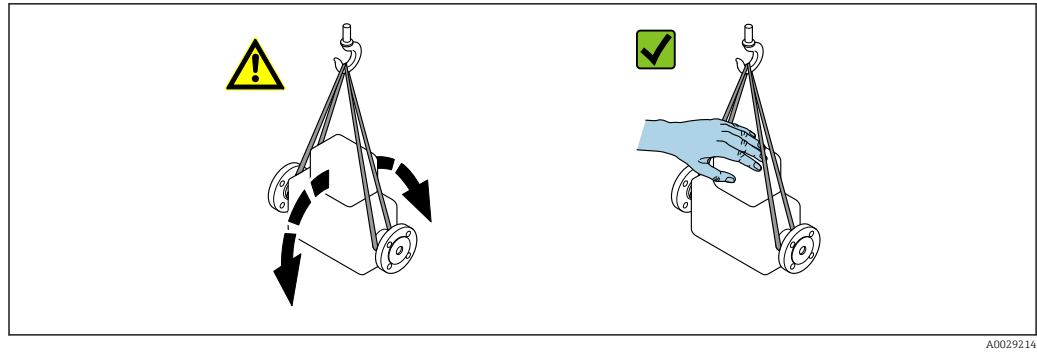

A0029214

Measuring devices with lifting lugs

⚠ CAUTION

Special transportation instructions for devices with lifting lugs

- ▶ Only use the lifting lugs fitted on the device or flanges to transport the device.
- ▶ The device must always be secured at two lifting lugs at least.

Transporting with a fork lift

If transporting in wood crates, the floor structure enables the crates to be lifted lengthwise or at both sides using a forklift.

4.3.3 Packaging disposal

All packaging materials are environmentally friendly and 100 % recyclable:

- Outer packaging of device
 - Polymer stretch wrap that complies with EU Directive 2002/95/EC (RoHS)
- Packaging
 - Wooden crate treated in accordance with ISPM 15 standard, confirmed by IPPC logo
 - Cardboard box in accordance with European packaging guideline 94/62EC, recyclability confirmed by Resy symbol
- Carrying and securing materials
 - Disposable plastic pallet
 - Plastic straps
 - Plastic adhesive strips
- Filler material
 - Paper pads

5 Installation



5.1 Installation conditions

- The recommended inlet and outlet specifications must be observed.
- The piping system and the device must be installed according to good engineering practice.
- Ensure the correct alignment and orientation of the sensor.
- Take measures to avoid or prevent condensation (e.g. condensation trap, thermal insulation etc.).
- Observe the maximum permissible ambient temperatures and medium temperature range.
- Install the measuring device in a shady location or use a weather protection cover.
- For mechanical reasons and to protect the pipe, support is recommended for heavy sensors .

5.1.1 Mounting position

Orientation

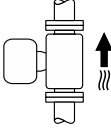
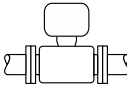
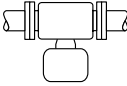
The direction of flow must match the direction of the arrow on the sensor. In the case of the bidirectional sensor, the arrow points in the positive direction.

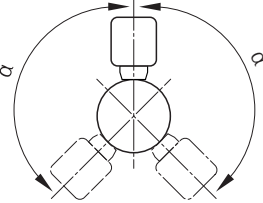
Orientation		Recommendation
Vertical orientation	 <small>A0015591</small>	<input checked="" type="checkbox"/> ¹⁾
Horizontal orientation, transmitter head up	 <small>A0015589</small>	<input checked="" type="checkbox"/> <input checked="" type="checkbox"/>
Horizontal orientation, transmitter head down	 <small>A0015590</small>	<input checked="" type="checkbox"/> ²⁾
Horizontal orientation, transmitter head at side	 <small>A0015592</small>	<input checked="" type="checkbox"/>
Inclined orientation, transmitter head down	 <small>A0015773</small>	<input checked="" type="checkbox"/> ²⁾

- 1) In the case of saturated or impure gases, vertical orientation is preferred in order to minimize condensation or contamination. For bidirectional sensors, select horizontal orientation.
- 2) Select inclined orientation ($\alpha = \text{approx. } 135^\circ$) for very wet or water-saturated gas (e.g. digester gas, undried compressed air), or if deposits or condensate are constantly present.

Pipes

The measuring device must be professionally installed, and the following points must be observed:

- Weld pipes professionally.
- Use seals of the correct size.
- Align flanges and seals correctly.

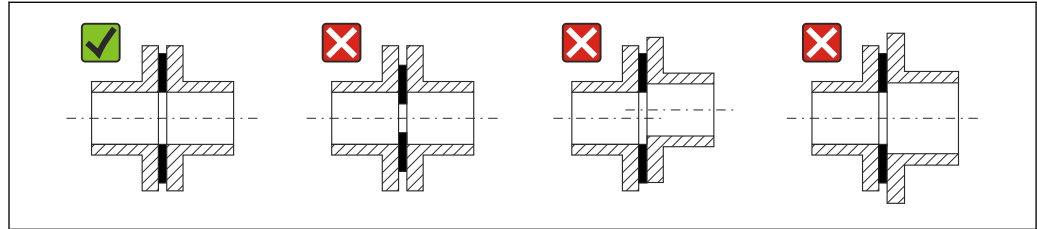

A0023496

- Following installation, the pipe must be free from dirt and particles in order to avoid damage to the sensors.
- For further information → ISO standard 14511.

Internal diameter

During the calibration, the device is adjusted with the following inlet pipes depending on the selected process connection. The corresponding internal diameters are listed in the following table:

SI units

DN [mm]	Inlet pipe internal diameter [mm]		
	DIN ¹⁾	Sch40 ²⁾	Sch80
15	17.3	15.7	13.9
25	28.5	26.7	24.3
40	43.1	40.9	38.1
50	54.5	52.6	49.2
65	70.3	62.7	59
80	83.7	78.1	73.7
100	107.1	102.4	97

1) Order code for "Process connection", option RAA "R thread EN10226-1 / ISO 7-1"

2) Order code for "Process connection", option NPT "MNPT thread, ASME"

US units

DN [in]	Inlet pipe internal diameter [in]		
	DIN ¹⁾	Sch40 ²⁾	Sch80
½	0.68	0.62	0.55
1	1.12	1.05	0.96
1 ½	1.7	1.61	1.5
2	2.15	2.07	1.94
2 ½	2.77	2.47	2.32

DN [in]	Inlet pipe internal diameter [in]		
	DIN ¹⁾	Sch40 ²⁾	Sch80
3	3.30	3.07	2.9
4	4.22	4.03	3.82

1) Order code for "Process connection", option RAA "R thread EN10226-1 / ISO 7-1"

2) Order code for "Process connection", option NPT "MNPT thread, ASME"

To ensure maximum measuring performance, choose an inlet pipe with an almost identical internal diameter.

Inlet and outlet runs

A fully developed flow profile is a prerequisite for optimum thermal flow measurement.

To achieve the best possible measuring performance, observe the following inlet and outlet runs at the very minimum.

- In the case of bidirectional sensors, also observe the recommended inlet run in the opposite direction.
- If several flow disturbances are present, use flow conditioners.
- Use flow conditioners if it is not possible to observe the required inlet runs.
- In the case of control valves, the interference influence depends on the valve type and opening degree. The recommended inlet run for control valves is $50 \times DN$.
- In the case of very light gases (helium, hydrogen), the recommended inlet run must be doubled.

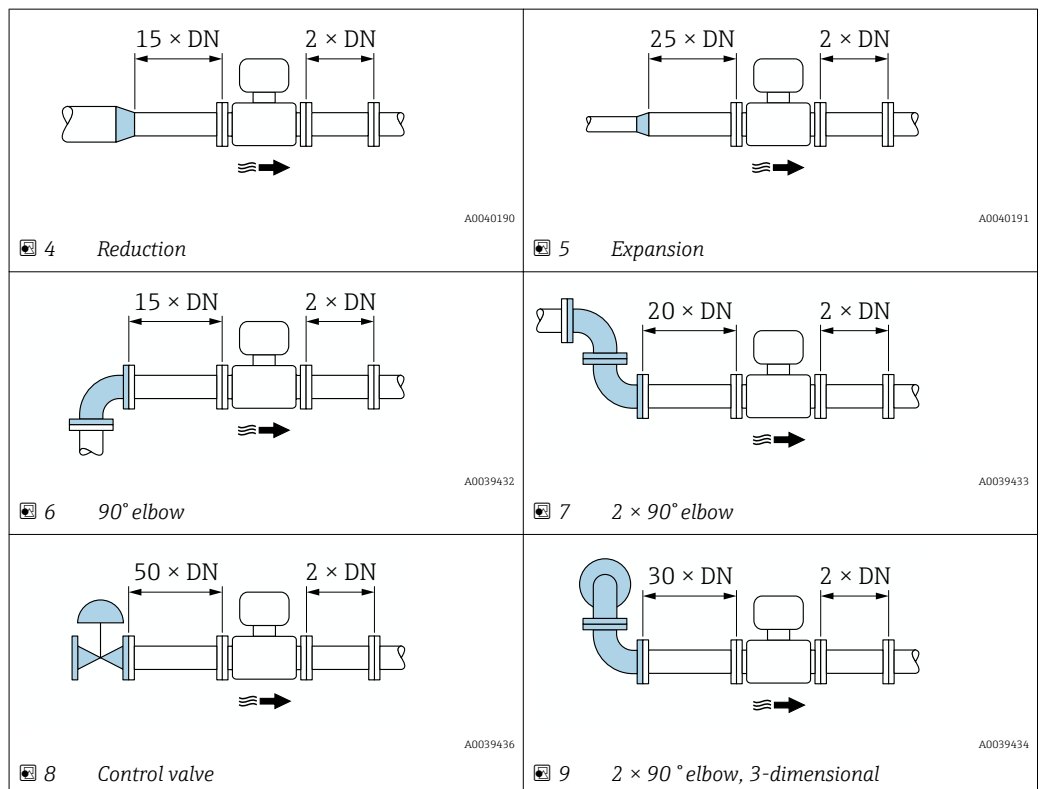

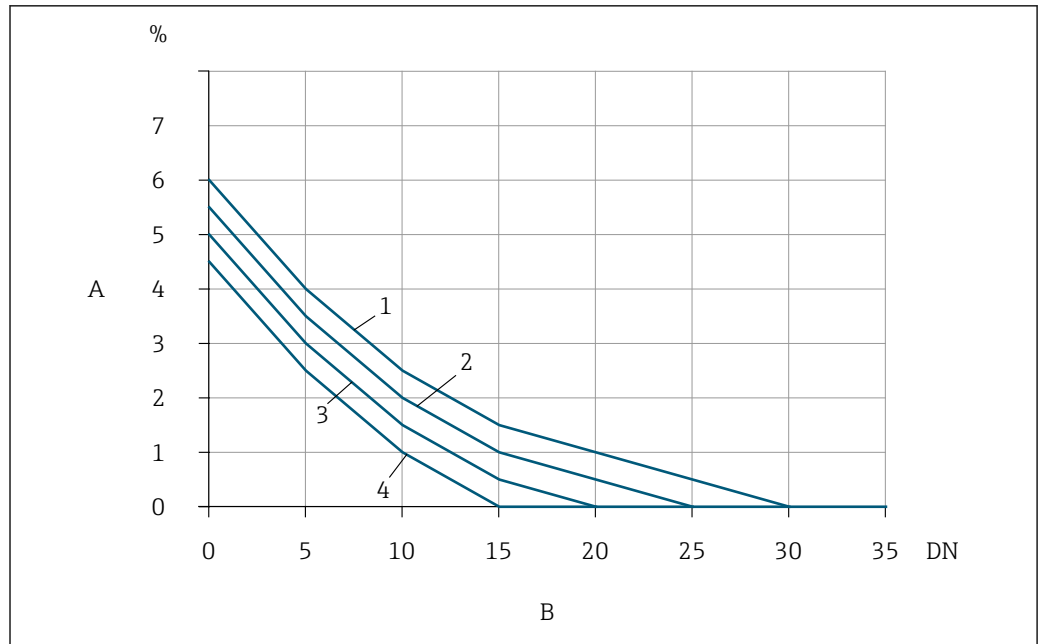

A0039507

10 The additional measured error to be expected without flow conditioners depending on the type of interference and inlet run

- A Additional measured error (%)
- B Inlet run (DN)
- 1 2 × 90° elbow, 3-dimensional
- 2 Expansion
- 3 2 × 90° elbow
- 4 Reduction or 90° elbow

Flow conditioner

Use flow conditioners if it is not possible to observe the required inlet runs. Flow conditioners improve the flow profile and therefore reduce the necessary inlet runs.

i The flow conditioner is permanently integrated in the flange and must be ordered with the device. It is not possible to retrofit a flow conditioner.

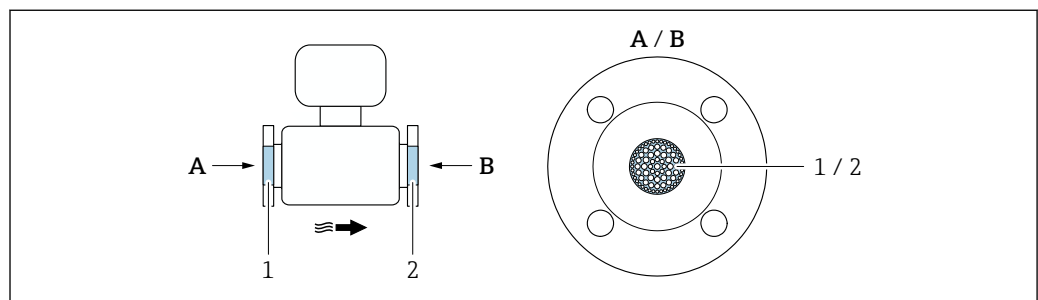

A0039539

- 1 Flow conditioner for unidirectional, bidirectional version and reverse flow detection
- 2 Optional, additional flow conditioner for bidirectional version

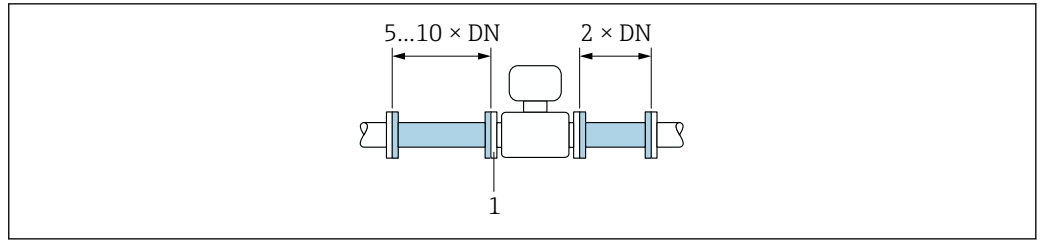

A0039425

11 Recommended inlet and outlet runs when using a flow conditioner

1 Flow conditioner

i In the case of bidirectional sensors, also observe the inlet run in the opposite direction.

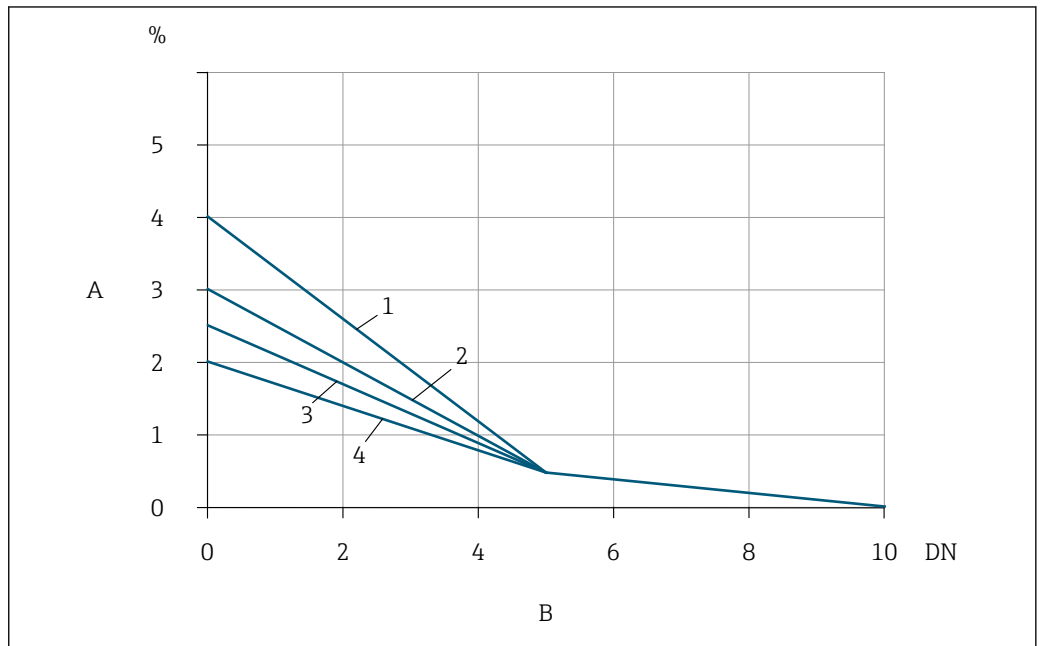

A0039508

12 The additional measured error to be expected with flow conditioners depending on the type of interference and inlet run

- A Additional measured error (%)
- B Inlet runs (DN)
- 1 $2 \times 90^\circ$ elbow, 3-dimensional
- 2 Expansion
- 3 $2 \times 90^\circ$ elbow
- 4 Reduction or 90° elbow

Outlet runs with pressure measuring points

Install the pressure measuring point downstream of the measuring system. This prevents the pressure transmitter from potentially affecting the flow in the measuring point.

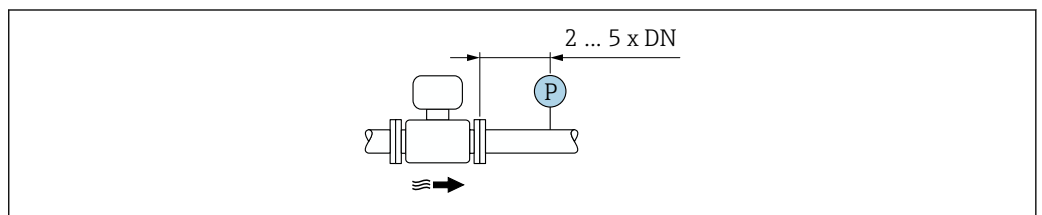

A0039438



13 Installation of a pressure measuring point (P = pressure transmitter)

5.1.2 Environment and process requirements

Ambient temperature range

Measuring device	<ul style="list-style-type: none"> ▪ -40 to +60 °C (-40 to +140 °F) ▪ Order code for "Test, certificate", option JP: -50 to +60 °C (-58 to +140 °F)
Readability of the local display	-20 to +60 °C (-4 to +140 °F) The readability of the display may be impaired at temperatures outside the temperature range.

- ▶ If operating outdoors:
Avoid direct sunlight, particularly in warm climatic regions.

 You can order a weather protection cover from Endress+Hauser →  167.

System pressure

Pressure-reducing valves and some compressor systems can generate significant process pressure variations that can distort the flow profile. This can produce an additional measured error. Suitable measures must be taken to reduce these pressure pulses, such as:

- The use of expansion tanks
- The use of inlet diffusers
- Positioning the measuring device further downstream

To avoid pulsating flow and contamination from oil/dirt in compressed air applications, it is recommended to install the measuring device downstream of filter, drying and storage devices. Do not install the measuring device directly after the compressor.

Thermal insulation

In the case of some fluids, it is important to keep the heat radiated from the sensor to the transmitter to a low level. A wide range of materials can be used for the required insulation.

If the gas is very wet or saturated with water (e.g. digester gas), the pipe and the sensor housing should be insulated, and heated where necessary, to prevent water droplets condensing on the sensing element.

NOTICE

Electronics overheating on account of thermal insulation!

- ▶ Recommended orientation: horizontal orientation, sensor connection housing pointing downwards.
- ▶ Do not insulate the sensor connection housing.
- ▶ Maximum permissible temperature at the lower end of the sensor connection housing: 80 °C (176 °F)
- ▶ Thermal insulation with extended neck free: We recommend that you do not insulate the extended neck in order to ensure optimum dissipation of heat.

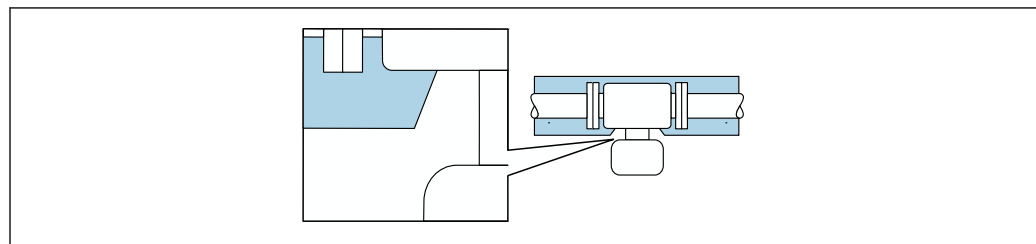

A0039419

 14 Thermal insulation with extended neck free

Heating

NOTICE

Electronics can overheat due to elevated ambient temperature!

- ▶ Observe maximum permitted ambient temperature for the transmitter .
- ▶ Depending on the fluid temperature, take the device orientation requirements into account .

NOTICE

Electronics overheating on account of thermal insulation!

- ▶ Recommended orientation: horizontal orientation, sensor connection housing pointing downwards.
- ▶ Do not insulate the sensor connection housing.
- ▶ Maximum permissible temperature at the lower end of the sensor connection housing: 80 °C (176 °F)
- ▶ Thermal insulation with extended neck free: We recommend that you do not insulate the extended neck in order to ensure optimum dissipation of heat.

NOTICE

Danger of overheating when heating

- ▶ Ensure that the temperature at the lower end of the transmitter housing does not exceed 80 °C (176 °F).
- ▶ Ensure that sufficient convection takes place at the transmitter neck.
- ▶ When using in potentially explosive atmospheres, observe the information in the device-specific Ex documentation. For detailed information on the temperature tables, see the separate document entitled "Safety Instructions" (XA) for the device.
- ▶ Ensure that a sufficiently large area of the transmitter neck remains exposed. The uncovered part serves as a radiator and protects the electronics from overheating and excessive cooling.

Heating options

If a fluid requires that no heat loss should occur at the sensor, users can avail of the following heating options:

- Electrical heating, e.g. with electric band heaters
- Via pipes carrying hot water or steam

Vibrations

NOTICE

Strong vibrations can damage the measuring device.

Can result in damage to the measuring device or the fastening units.

- ▶ Pay attention to information on the vibration and shock resistance →  184

5.1.3 Special mounting instructions

Zero point adjustment

All measuring devices are calibrated in accordance with state-of-the-art technology. Calibration takes place under reference conditions . Therefore, a zero point adjustment in the field is generally not required.

Experience shows that zero point adjustment is advisable only in special cases:

- If strict measuring accuracy requirements apply.
- Under extreme process or operating conditions (e.g. very high process temperatures or light gases (helium, hydrogen)).

Weather protection cover

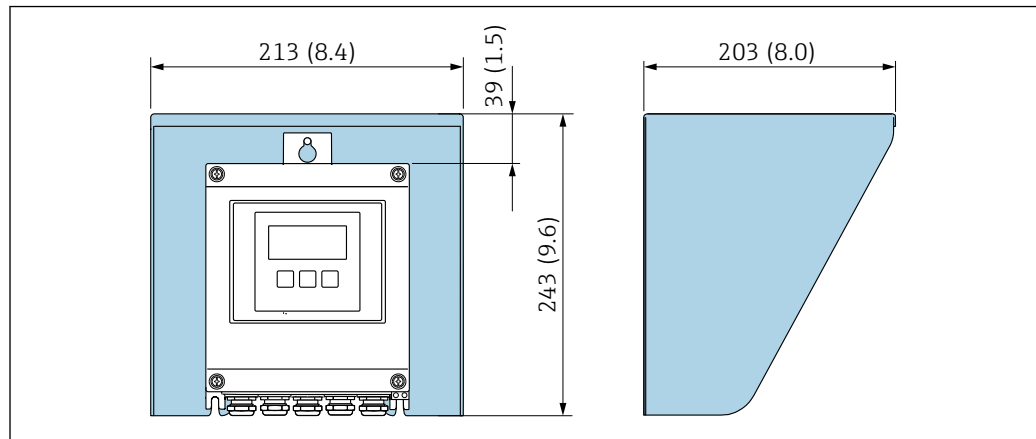

15 Weather protection cover for Proline 500; engineering unit mm (in)

5.2 Mounting the measuring device

5.2.1 Required tool

For sensor

For flanges and other process connections: Corresponding mounting tools

5.2.2 Preparing the measuring device

1. Remove all remaining transport packaging.
2. Remove any protective covers or protective caps present from the sensor.
3. Remove stick-on label on the electronics compartment cover.

5.2.3 Mounting the measuring device

WARNING

Danger due to improper process sealing!

- ▶ Ensure that the inside diameters of the gaskets are greater than or equal to that of the process connections and piping.
- ▶ Ensure that the seals are clean and undamaged.
- ▶ Secure the seals correctly.

1. Ensure that the direction of the arrow on the sensor matches the flow direction of the fluid.
2. Install the measuring device or turn the transmitter housing so that the cable entries do not point upwards.

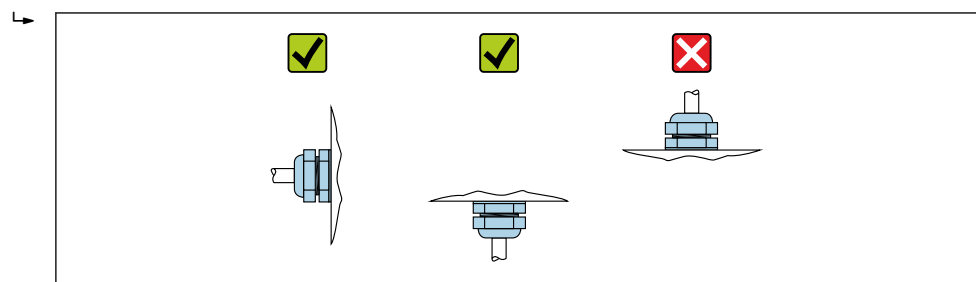

A0029263

5.2.4 Mounting the transmitter housing: Proline 500 – digital

⚠ CAUTION

Ambient temperature too high!

Danger of electronics overheating and housing deformation.

- ▶ Do not exceed the permitted maximum ambient temperature .
- ▶ If operating outdoors: Avoid direct sunlight and exposure to weathering, particularly in warm climatic regions.

⚠ CAUTION

Excessive force can damage the housing!

- ▶ Avoid excessive mechanical stress.

The transmitter can be mounted in the following ways:

- Post mounting
- Wall mounting

Post mounting

⚠ WARNING

Excessive tightening torque applied to the fixing screws!

Risk of damaging the plastic transmitter.

- ▶ Tighten the fixing screws as per the tightening torque: 2 Nm (1.5 lbf ft)

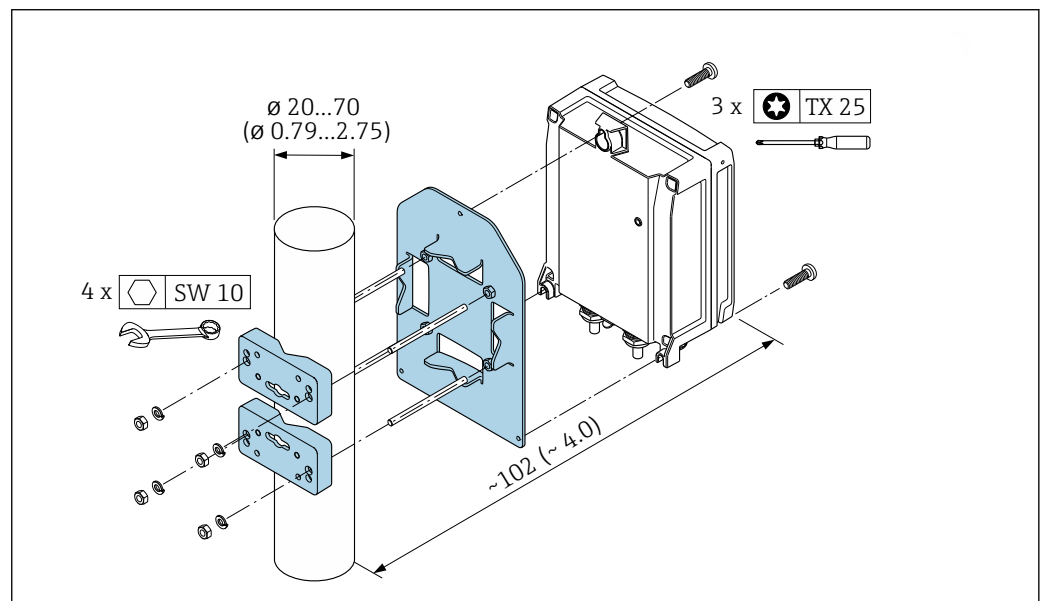

16 Engineering unit mm (in)

A0029051

Wall mounting

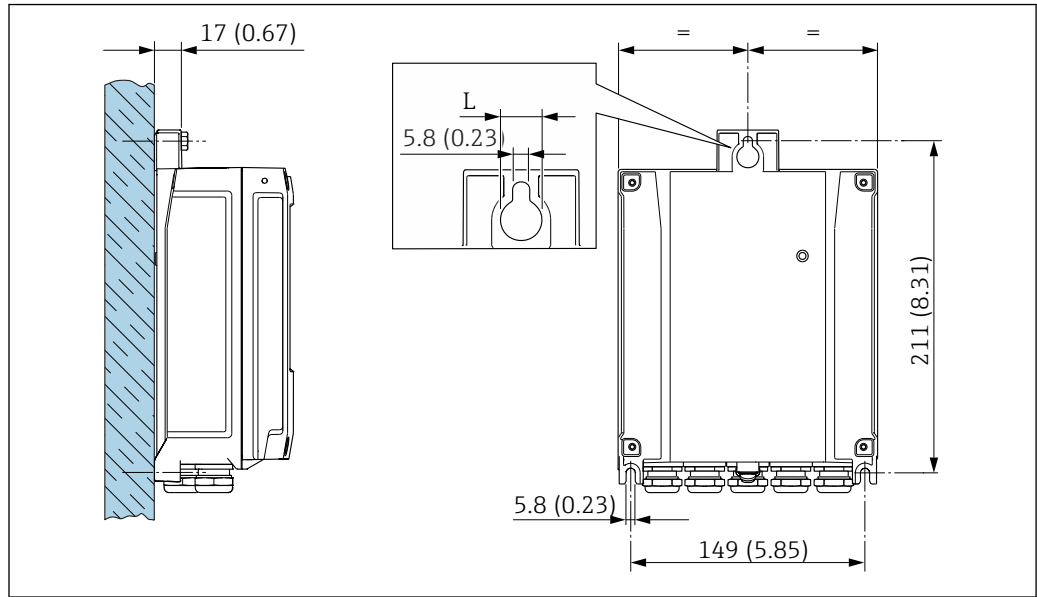

17 Engineering unit mm (in)

L Depends on order code for "Transmitter housing"

Order code for "Transmitter housing"

- Option A, aluminum coated: L = 14 mm (0.55 in)
- Option D, polycarbonate: L = 13 mm (0.51 in)

1. Drill the holes.
2. Insert wall plugs into the drilled holes.
3. Screw in the securing screws slightly at first.
4. Fit the transmitter housing over the securing screws and mount in place.
5. Tighten the securing screws.

5.3 Post-installation check

Is the device undamaged (visual inspection)?	<input type="checkbox"/>
Does the measuring device conform to the measuring point specifications? For example: ▪ Process temperature → 186 ▪ Process pressure (refer to the "Pressure-temperature ratings" section of the "Technical Information" document) ▪ Ambient temperature → 26 ▪ Measuring range → 171	<input type="checkbox"/>
Has the correct orientation been selected for the sensor → 21? ▪ According to sensor type ▪ According to medium properties ▪ According to medium temperature ▪ According to process pressure	<input type="checkbox"/>
Does the arrow on the sensor match the actual direction of flow of the medium through the piping?	<input type="checkbox"/>
Have sufficient inlet and outlet runs been provided upstream and downstream of the measuring point → 23?	<input type="checkbox"/>
Is the device adequately protected from precipitation and direct sunlight?	<input type="checkbox"/>

Is the device protected against overheating?	<input type="checkbox"/>
Is the device protected against excessive vibrations?	<input type="checkbox"/>
Gas property checked (e.g. purity, dryness, cleanness)?	<input type="checkbox"/>
Are the measuring point identification and labeling correct (visual inspection)?	<input type="checkbox"/>
Are the securing screw and securing clamp tightened securely?	<input type="checkbox"/>

6 Electrical connection

NOTICE

The measuring device does not have an internal circuit breaker.

- ▶ For this reason, assign the measuring device a switch or power-circuit breaker so that the power supply line can be easily disconnected from the mains.
- ▶ Although the measuring device is equipped with a fuse, additional overcurrent protection (maximum 10 A) should be integrated into the system installation.

6.1 Electrical safety

In accordance with applicable federal/national regulations.

6.2 Connection conditions

6.2.1 Required tools

- For cable entries: Use corresponding tools
- For securing clamp: Allen key 3 mm
- Wire stripper
- When using stranded cables: crimper for wire end ferrule
- For removing cables from terminal: Flat blade screwdriver ≤ 3 mm (0.12 in)

6.2.2 Requirements for connecting cable

The connecting cables provided by the customer must fulfill the following requirements.

Protective grounding cable for the outer ground terminal

Conductor cross-section ≤ 2.08 mm² (14 AWG)

Grounding impedance must be less than 2 Ω .

Permitted temperature range

- The installation guidelines that apply in the country of installation must be observed.
- The cables must be suitable for the minimum and maximum temperatures to be expected.

Power supply cable (incl. conductor for the inner ground terminal)

Standard installation cable is sufficient.

Signal cable

Modbus RS485

The EIA/TIA-485 standard specifies two types of cable (A and B) for the bus line which can be used for every transmission rate. Cable type A is recommended.

Cable type	A
Characteristic impedance	135 to 165 Ω at a measuring frequency of 3 to 20 MHz
Cable capacitance	< 30 pF/m
Wire cross-section	> 0.34 mm ² (22 AWG)
Cable type	Twisted pairs
Loop resistance	≤ 110 Ω /km

Signal damping	Max. 9 dB over the entire length of the cable cross-section
Shield	Copper braided shielding or braided shielding with foil shield. When grounding the cable shield, observe the grounding concept of the plant.

Current output 0/4 to 20 mA

Standard installation cable is sufficient.

Pulse/frequency/switch output

Standard installation cable is sufficient.

Relay output

Standard installation cable is sufficient.

Current input 0/4 to 20 mA

Standard installation cable is sufficient.

Status input

Standard installation cable is sufficient.

Cable diameter

- Cable glands supplied:
M20 × 1.5 with cable \varnothing 6 to 12 mm (0.24 to 0.47 in)
- Spring-loaded terminals: Suitable for strands and strands with ferrules.
Conductor cross-section 0.2 to 2.5 mm² (24 to 12 AWG).

Choice of connecting cable between the transmitter and sensor

Depends on the type of transmitter and the installation zones

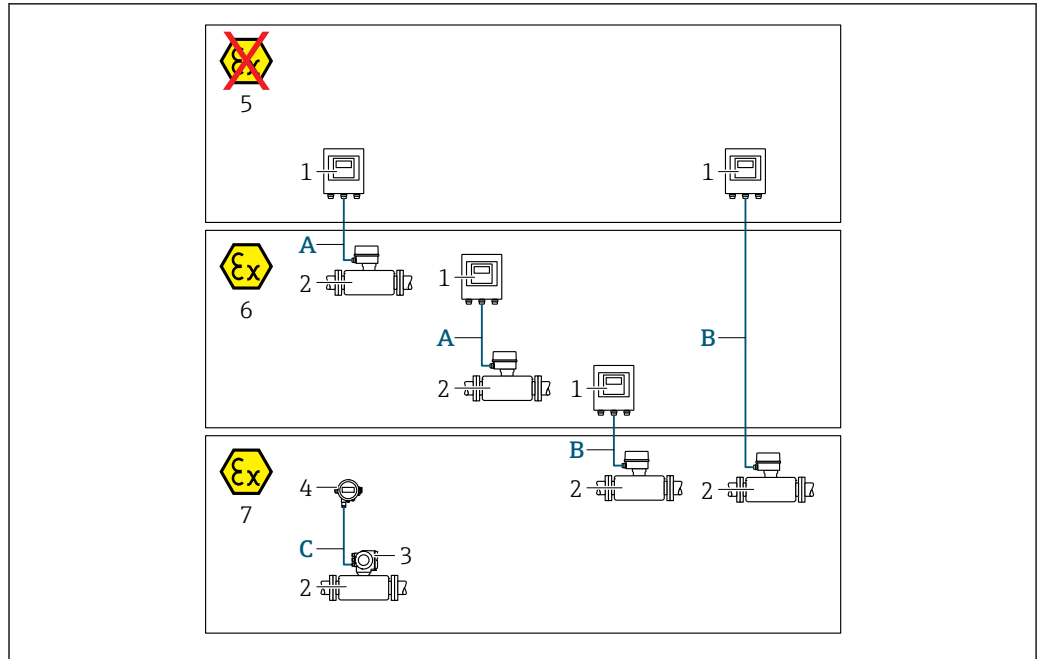

A0042080

- 1 Proline 500 – digital transmitter
- 2 Sensor t-mass
- 3 Proline 300 transmitter
- 4 Remote display (DKX001)
- 5 Non-hazardous area
- 6 Hazardous area: Zone 2; Class I, Division 2
- 7 Hazardous area: Zone 1; Class I, Division 1
- A Standard cable to 500 – digital transmitter
 Transmitter installed in the non-hazardous area or hazardous area: Zone 2; Class I, Division 2 / sensor installed in the hazardous area: Zone 2; Class I, Division 2
- B Standard cable to 500 – digital transmitter → 35
 Transmitter installed in the hazardous area: Zone 2; Class I, Division 2 / sensor installed in the hazardous area: Zone 1; Class I, Division 1
- C Standard cable to remote display
 Transmitter 300 and remote display installed in the hazardous area: Zone 1; Class I, Division 1

i For applications with operation in Zone 1; Class 1, Division 1, we recommend the use of the compact version with the remote display. In this case, the display of the Proline 300 transmitter is a blind version without local operation.

A: Connecting cable between sensor and transmitter: Proline 500 – digital

Standard cable

A standard cable with the following specifications can be used as the connecting cable.

Design	4 cores (2 pairs); uninsulated stranded CU wires; pair-stranded with common shield
Shielding	Tin-plated copper-braid, optical cover ≥ 85 %
Loop resistance	Power supply line (+, -): maximum 10 Ω
Cable length	Maximum 300 m (1000 ft), see the following table.

Cross-section	Cable length [max.]
0.34 mm ² (AWG 22)	80 m (270 ft)
0.50 mm ² (AWG 20)	120 m (400 ft)
0.75 mm ² (AWG 18)	180 m (600 ft)

Cross-section	Cable length [max.]
1.00 mm ² (AWG 17)	240 m (800 ft)
1.50 mm ² (AWG 15)	300 m (1000 ft)

Optionally available connecting cable

Design	2 × 2 × 0.34 mm ² (AWG 22) PVC cable ¹⁾ with common shield (2 pairs, uninsulated stranded CU wires; pair-stranded)
Flame resistance	According to DIN EN 60332-1-2
Oil-resistance	According to DIN EN 60811-2-1
Shielding	Tin-plated copper-braid, optical cover ≥ 85 %
Operating temperature	When mounted in a fixed position: -50 to +105 °C (-58 to +221 °F); when cable can move freely: -25 to +105 °C (-13 to +221 °F)
Available cable length	Fixed: 20 m (65 ft); variable: up to maximum 50 m (164 ft)

1) UV radiation can impair the cable outer sheath. Protect the cable from direct sunshine where possible.

B: Connecting cable between sensor and transmitter: Proline 500 - digital

Standard cable

A standard cable with the following specifications can be used as the connecting cable.

Design	4, 6, 8 cores (2, 3, 4 pairs); uninsulated stranded CU wires; pair-stranded with common shield
Shielding	Tin-plated copper-braid, optical cover ≥ 85 %
Capacitance C	Maximum 760 nF IIC, maximum 4.2 μF IIB
Inductance L	Maximum 26 μH IIC, maximum 104 μH IIB
Inductance/resistance ratio (L/R)	Maximum 8.9 μH/Ω IIC, maximum 35.6 μH/Ω IIB (e.g. in accordance with IEC 60079-25)
Loop resistance	Power supply line (+, -): maximum 5 Ω
Cable length	Maximum 100 m (330 ft), see the following table.

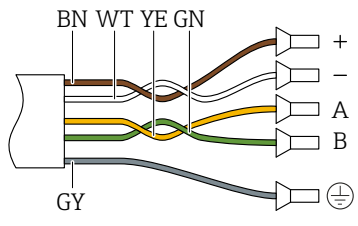
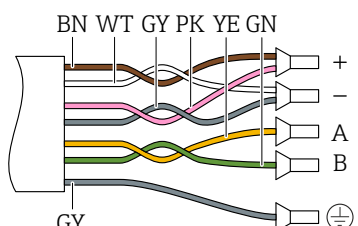
Cross-section	Cable length [max.]	Termination
2 x 2 x 0.50 mm ² (AWG 20)	50 m (165 ft)	2 x 2 x 0.50 mm ² (AWG 20)  <ul style="list-style-type: none"> ■ +, - = 0.5 mm² ■ A, B = 0.5 mm²
3 x 2 x 0.50 mm ² (AWG 20)	100 m (330 ft)	3 x 2 x 0.50 mm ² (AWG 20)  <ul style="list-style-type: none"> ■ +, - = 1.0 mm² ■ A, B = 0.5 mm²

Optionally available connecting cable

Connecting cable for	Zone 1; Class I, Division 1
Standard cable	2 × 2 × 0.5 mm ² (AWG 20) PVC cable ¹⁾ with common shield (2 pairs, pair-stranded)
Flame resistance	According to DIN EN 60332-1-2
Oil-resistance	According to DIN EN 60811-2-1
Shielding	Tin-plated copper-braid, optical cover ≥ 85 %
Operating temperature	When mounted in a fixed position: -50 to +105 °C (-58 to +221 °F); when cable can move freely: -25 to +105 °C (-13 to +221 °F)
Available cable length	Fixed: 20 m (65 ft); variable: up to maximum 50 m (165 ft)

1) UV radiation can impair the cable outer sheath. Protect the cable from direct sunshine where possible.

6.2.3 Terminal assignment

Transmitter: supply voltage, input/outputs

The terminal assignment of the inputs and outputs depends on the individual order version of the device. The device-specific terminal assignment is documented on an adhesive label in the terminal cover.

Supply voltage		Input/output 1		Input/output 2		Input/output 3		Input/output 4	
1 (+)	2 (-)	26 (B)	27 (A)	24 (+)	25 (-)	22 (+)	23 (-)	20 (+)	21 (-)
Device-specific terminal assignment: adhesive label in terminal cover.									

Transmitter and sensor connection housing: connecting cable

The sensor and transmitter, which are mounted in separate locations, are interconnected by a connecting cable. The cable is connected via the sensor connection housing and the transmitter housing.

Terminal assignment and connection of the connecting cable:

Proline 500 – digital →  38

6.2.4 Shielding and grounding

Shielding and grounding concept

1. Maintain electromagnetic compatibility (EMC).
2. Take explosion protection into consideration.
3. Pay attention to the protection of persons.
4. Comply with national installation regulations and guidelines.
5. Observe cable specifications .
6. Keep the stripped and twisted lengths of cable shield to the ground terminal as short as possible.
7. Shield cables fully.

Grounding of the cable shield

NOTICE

In systems without potential matching, the multiple grounding of the cable shield causes mains frequency equalizing currents!

Damage to the bus cable shield.

- ▶ Only ground the bus cable shield to either the local ground or the protective ground at one end.
- ▶ Insulate the shield that is not connected.

To comply with EMC requirements:

1. Ensure the cable shield is grounded to the potential matching line at multiple points.
2. Connect every local ground terminal to the potential matching line.

6.2.5 Preparing the measuring device

Carry out the steps in the following order:

1. Mount the sensor and transmitter.
2. Connection housing, sensor: Connect connecting cable.
3. Transmitter: Connect connecting cable.
4. Transmitter: Connect signal cable and cable for supply voltage.

NOTICE

Insufficient sealing of the housing!

Operational reliability of the measuring device could be compromised.

- ▶ Use suitable cable glands corresponding to the degree of protection.

1. Remove dummy plug if present.
2. If the measuring device is supplied without cable glands:
Provide suitable cable gland for corresponding connecting cable.
3. If the measuring device is supplied with cable glands:
Observe requirements for connecting cables →  32.

6.3 Connecting the measuring device: Proline 500 - digital

NOTICE

Limitation of electrical safety due to incorrect connection!

- ▶ Have electrical connection work carried out by appropriately trained specialists only.
- ▶ Observe applicable federal/national installation codes and regulations.
- ▶ Comply with local workplace safety regulations.
- ▶ Always connect the protective ground cable ⊕ before connecting additional cables.
- ▶ For use in potentially explosive atmospheres, observe the information in the device-specific Ex documentation.

6.3.1 Connecting the connecting cable

⚠ WARNING

Risk of damaging the electronic components!

- ▶ Connect the sensor and transmitter to the same potential equalization.
- ▶ Only connect the sensor to a transmitter with the same serial number.
- ▶ Ground the connection housing of the sensor via the external screw terminal.

Connecting cable terminal assignment

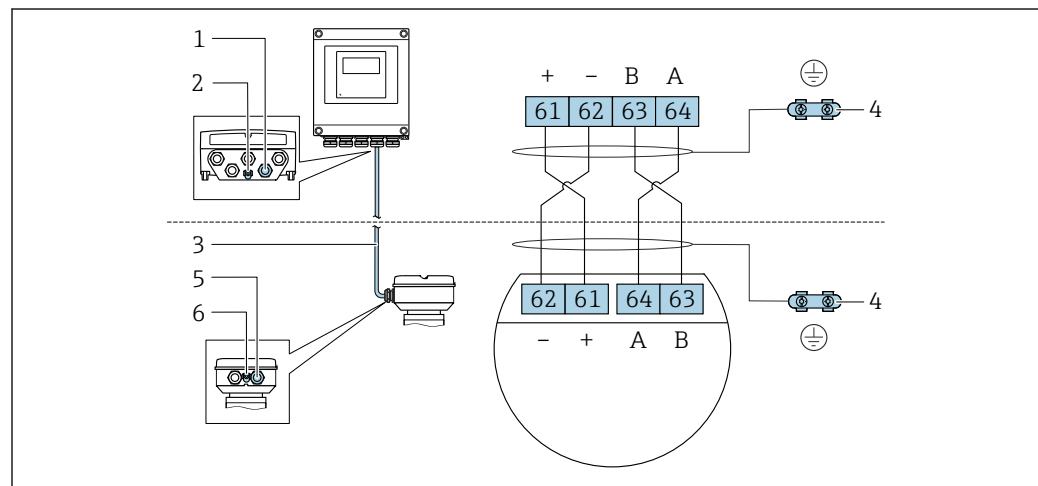

A0028198

- 1 Cable entry for cable on transmitter housing
- 2 Protective earth (PE)
- 3 Connecting cable ISEM communication
- 4 Grounding via ground connection; on device plug versions grounding is through the plug itself
- 5 Cable entry for cable or connection of device plug on sensor connection housing
- 6 Protective earth (PE)

Connecting the connecting cable to the sensor connection housing

Connection via terminals with order code for "Sensor connection housing":

- Option A "Aluminum, coated" → 📄 39
- Option L "Cast, stainless" → 📄 39

Connecting the connecting cable to the transmitter

The cable is connected to the transmitter via terminals → 📄 40.

Connecting the sensor connection housing via terminals

For the device version with the order code for "Sensor connection housing":

- Option **A** "Aluminum coated"
- Option **L** "Cast, stainless"

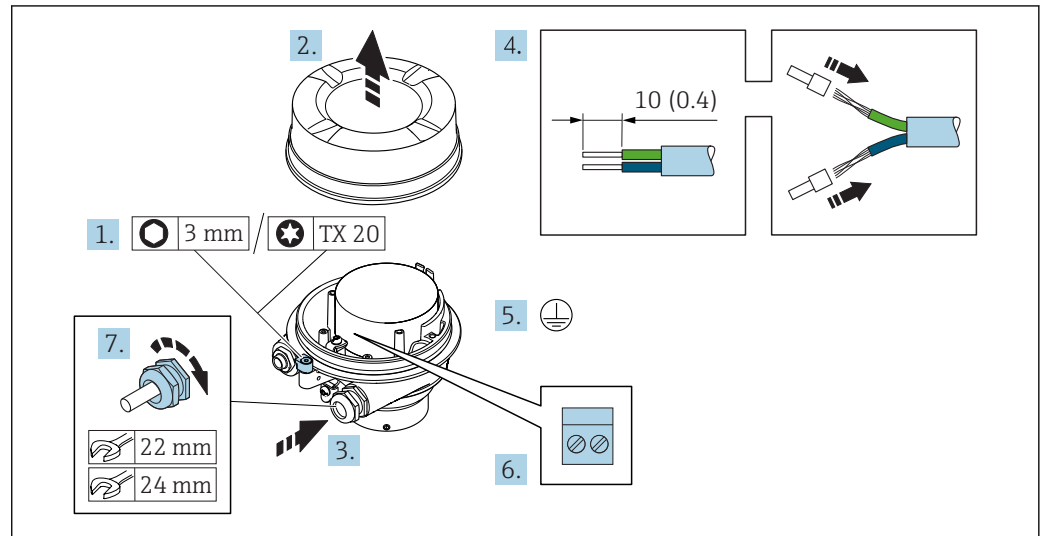

A0029616

1. Loosen the securing clamp of the housing cover.
2. Unscrew the housing cover.
3. Push the cable through the cable entry. To ensure tight sealing, do not remove the sealing ring from the cable entry.
4. Strip the cable and cable ends. In the case of stranded cables, fit ferrules.
5. Connect the protective ground.
6. Connect the cable in accordance with the connecting cable terminal assignment.
7. Firmly tighten the cable glands.
 - ↳ This concludes the process for connecting the connecting cable.

⚠ WARNING

Housing degree of protection voided due to insufficient sealing of the housing.

- ▶ Screw in the thread on the cover without using any lubricant. The thread on the cover is coated with a dry lubricant.

8. Screw on the housing cover.
9. Tighten the securing clamp of the housing cover.

Connecting the connecting cable to the transmitter

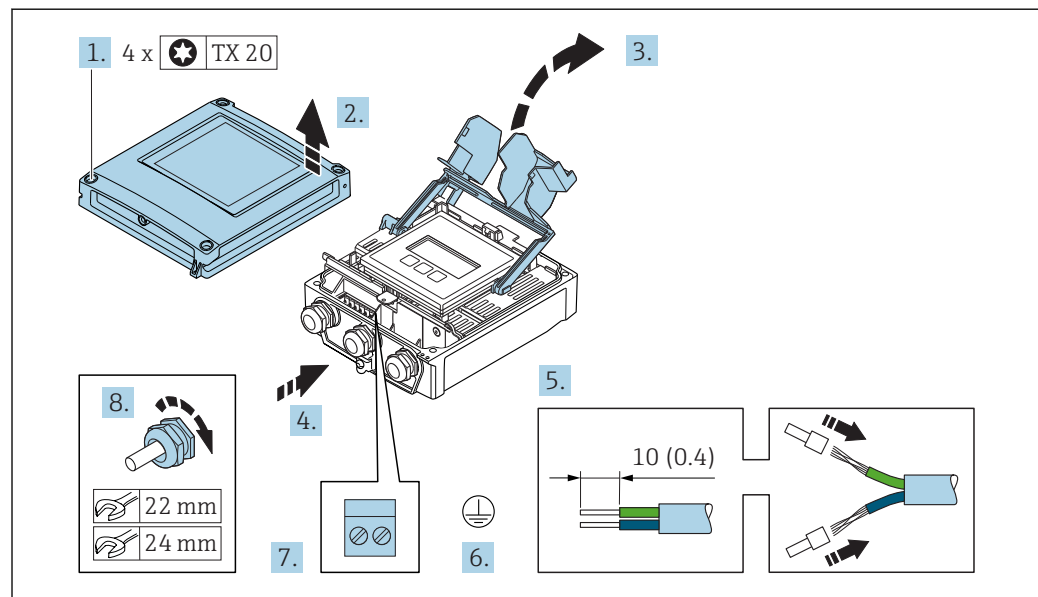

A0029597

1. Loosen the 4 fixing screws on the housing cover.
2. Open the housing cover.
3. Fold open the terminal cover.
4. Push the cable through the cable entry. To ensure tight sealing, do not remove the sealing ring from the cable entry.
5. Strip the cable and cable ends. In the case of stranded cables, fit ferrules.
6. Connect the protective ground.
7. Connect the cable in accordance with the connecting cable terminal assignment → 38.
8. Firmly tighten the cable glands.
 - ↳ This concludes the process for connecting the connecting cable.
9. Close the housing cover.
10. Tighten the securing screw of the housing cover.
11. After connecting the connecting cable:
 - Connect the signal cable and the supply voltage cable → 41.

6.3.2 Connecting the signal cable and the supply voltage cable

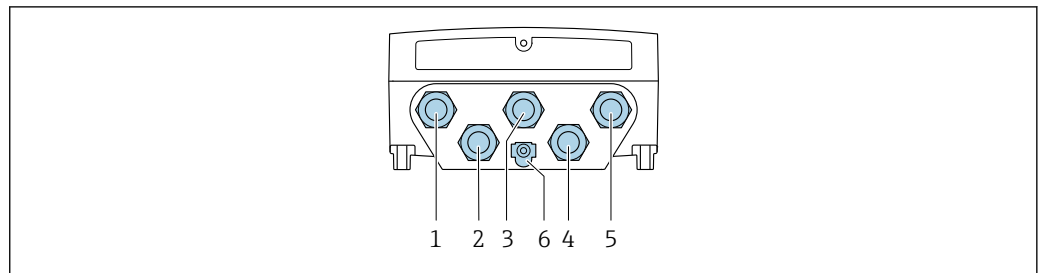

A0028200

- 1 Terminal connection for supply voltage
- 2 Terminal connection for signal transmission, input/output
- 3 Terminal connection for signal transmission, input/output
- 4 Terminal connection for connecting cable between sensor and transmitter
- 5 Terminal connection for signal transmission, input/output; optional: connection for external WLAN antenna
- 6 Protective earth (PE)

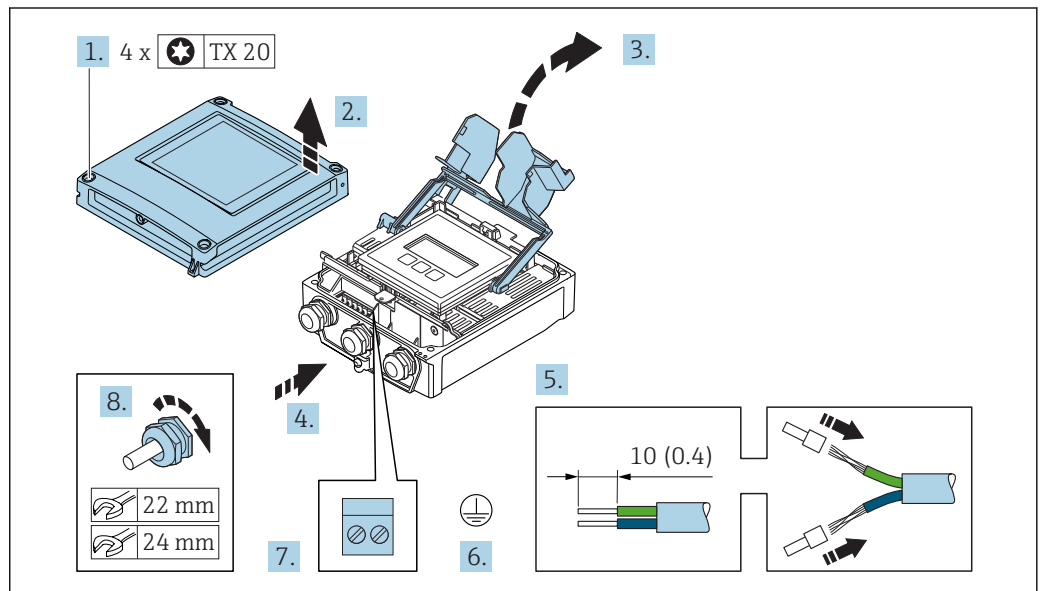

A0029597

1. Loosen the 4 fixing screws on the housing cover.
2. Open the housing cover.
3. Fold open the terminal cover.
4. Push the cable through the cable entry. To ensure tight sealing, do not remove the sealing ring from the cable entry.
5. Strip the cable and cable ends. In the case of stranded cables, fit ferrules.
6. Connect the protective ground.
7. Connect the cable in accordance with the terminal assignment .
 - ↳ **Signal cable terminal assignment:** The device-specific terminal assignment is documented on an adhesive label in the terminal cover.
 - Supply voltage terminal assignment:** Adhesive label in the terminal cover or → 36.
8. Firmly tighten the cable glands.
 - ↳ This concludes the cable connection process.
9. Close the terminal cover.
10. Close the housing cover.

⚠ WARNING

Housing degree of protection may be voided due to insufficient sealing of the housing.

- ▶ Screw in the screw without using any lubricant.

⚠ WARNING

Excessive tightening torque applied to the fixing screws!

Risk of damaging the plastic transmitter.

- ▶ Tighten the fixing screws as per the tightening torque: 2 Nm (1.5 lbf ft)

11. Tighten the 4 fixing screws on the housing cover.

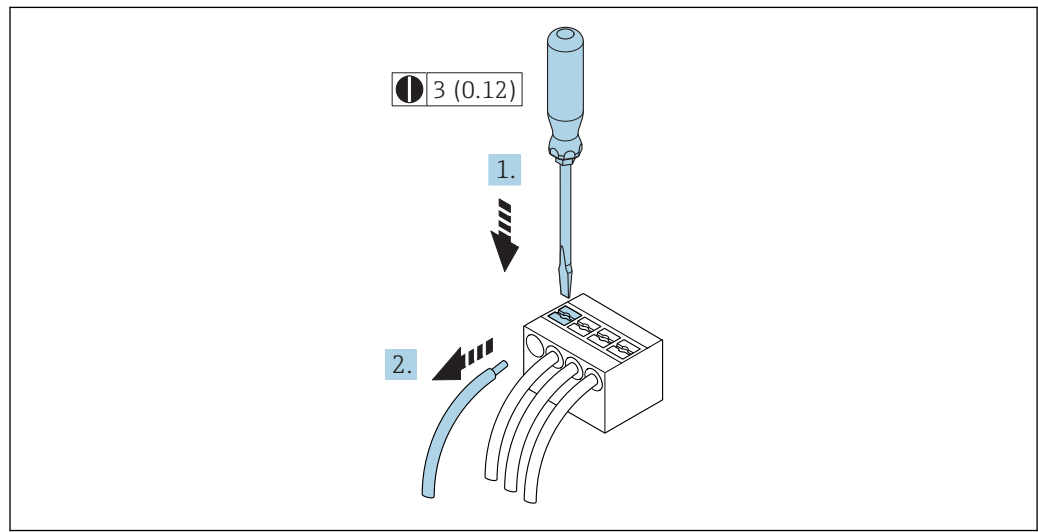
Removing a cable

18 Engineering unit mm (in)

1. To remove a cable from the terminal, use a flat-blade screwdriver to push the slot between the two terminal holes
2. while simultaneously pulling the cable end out of the terminal.

6.4 Ensuring potential equalization

6.4.1 Requirements

No special measures for potential equalization are required.

6.5 Special connection instructions

6.5.1 Connection examples

Modbus RS485

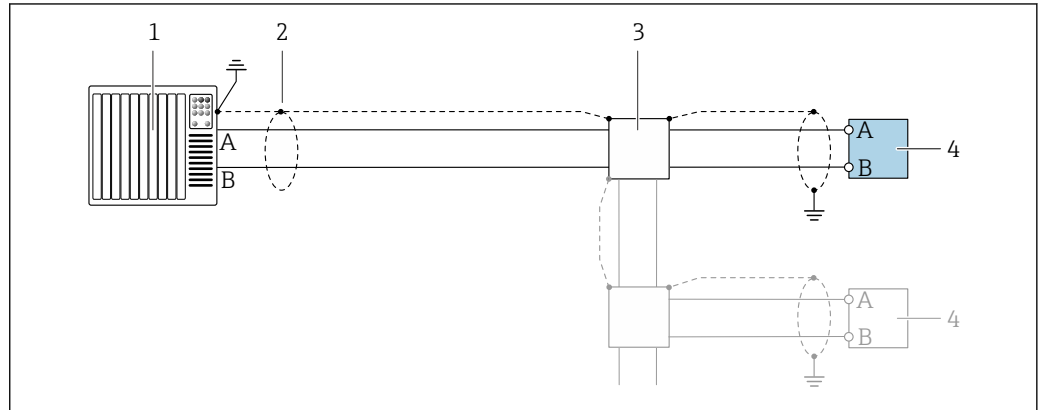

A0028765

19 Connection example for Modbus RS485, non-hazardous area and Zone 2; Class I, Division 2

- 1 Control system (e.g. PLC)
- 2 Cable shield provided at one end. The cable shield must be grounded at both ends to comply with EMC requirements; observe cable specifications
- 3 Distribution box
- 4 Transmitter

Current output 4-20 mA

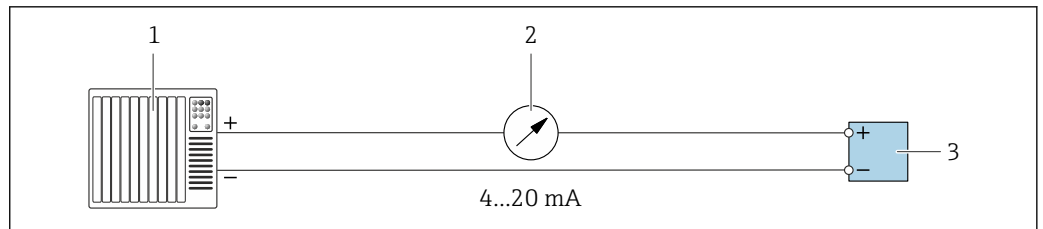

A0028758

20 Connection example for 4-20 mA current output (active)

- 1 Automation system with current input (e.g. PLC)
- 2 Analog display unit: observe maximum load
- 3 Transmitter

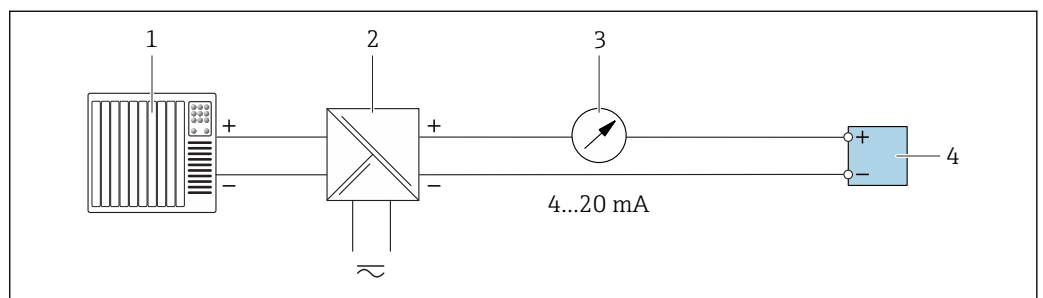

A0028759

21 Connection example for 4-20 mA current output (passive)

- 1 Automation system with current input (e.g. PLC)
- 2 Active barrier for power supply (e.g. RN221N)
- 3 Analog display unit: observe maximum load
- 4 Transmitter

Pulse/frequency output

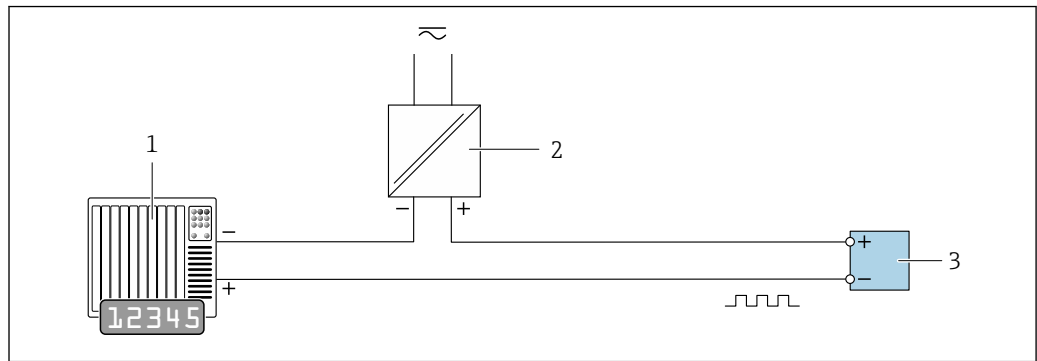

A0028761

22 Connection example for pulse/frequency output (passive)

- 1 Automation system with pulse/frequency input (e.g. PLC)
- 2 Power supply
- 3 Transmitter: Observe input values → 176

Switch output

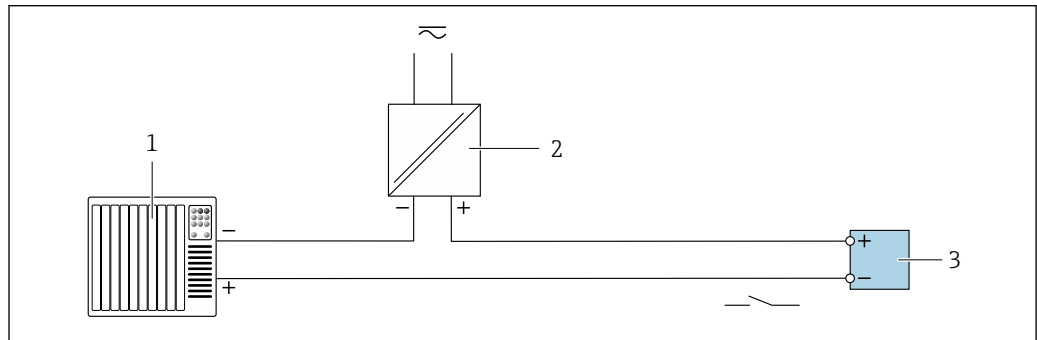

A0028760

23 Connection example for switch output (passive)

- 1 Automation system with switch input (e.g. PLC)
- 2 Power supply
- 3 Transmitter: Observe input values → 176

Relay output

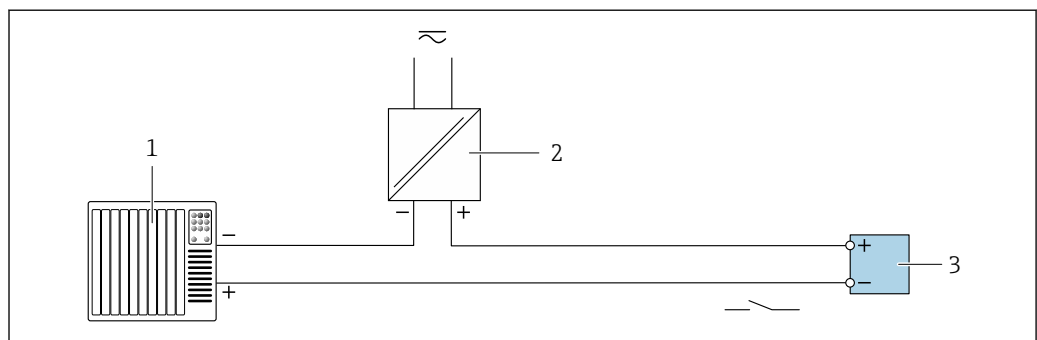

A0028760

24 Connection example for relay output (passive)

- 1 Automation system with relay input (e.g. PLC)
- 2 Power supply
- 3 Transmitter: Observe input values → 178

Current input

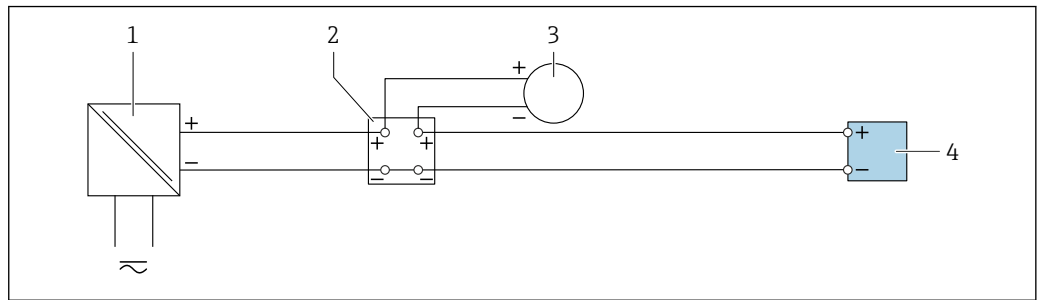

A0028915

25 Connection example for 4 to 20 mA current input

- 1 Power supply
- 2 Terminal box
- 3 External measuring device (to read in pressure or temperature, for instance)
- 4 Transmitter

Status input

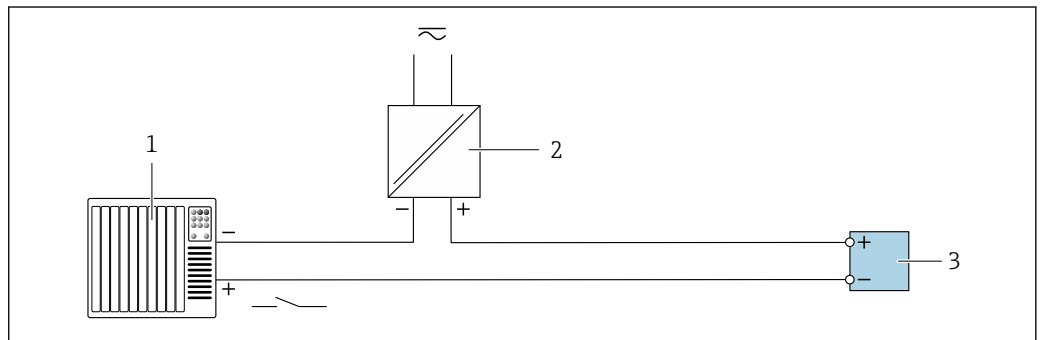

A0028764

26 Connection example for status input

- 1 Automation system with status output (e.g. PLC)
- 2 Power supply
- 3 Transmitter

6.6 Hardware settings

6.6.1 Setting the device address

The device address must always be configured for a Modbus slave. The valid device addresses are in the range from 1 to 247. Each address may only be assigned once in a Modbus RS485 network. If an address is not configured correctly, the measuring device is not recognized by the Modbus master. All measuring devices are delivered from the factory with the device address 247 and with the "software addressing" address mode.

Proline 500 – digital transmitter

Hardware addressing

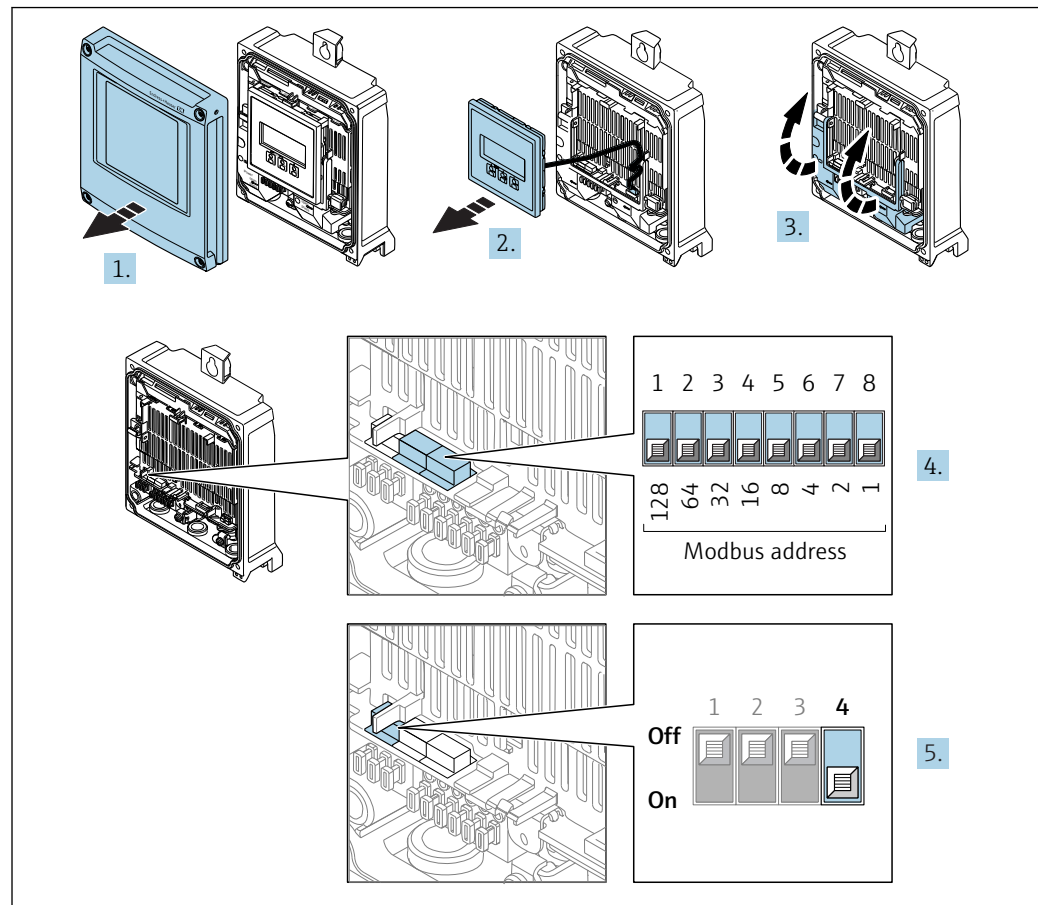

A0029677

1. Open the housing cover.
2. Remove the display module.
3. Fold open the terminal cover.
4. Set the desired device address using the DIP switches.
5. To switch addressing from software addressing to hardware addressing: set the DIP switch to **On**.
 - ↳ The change of device address takes effect after 10 seconds.

Software addressing

- ▶ To switch addressing from hardware addressing to software addressing: set the DIP switch to **Off**.
 - ↳ The device address configured in the **Device address** parameter takes effect after 10 seconds.

6.6.2 Enabling the terminating resistor

To avoid incorrect communication transmission caused by impedance mismatch, terminate the Modbus RS485 cable correctly at the start and end of the bus segment.

Proline 500 – digital transmitter

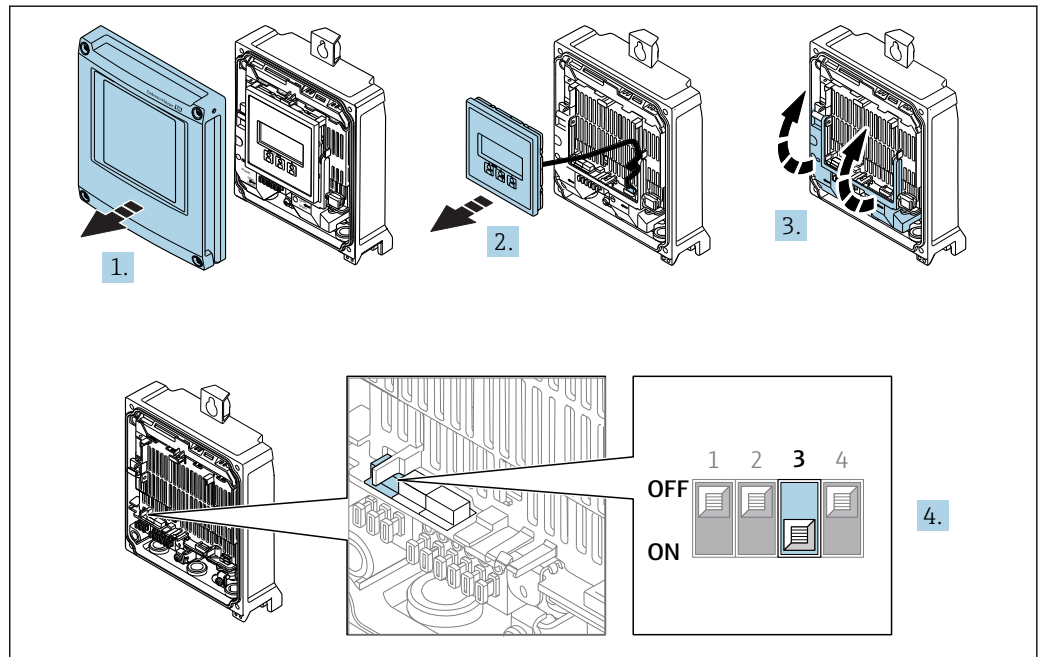

A0029675

1. Open the housing cover.
2. Remove the display module.
3. Fold open the terminal cover.
4. Switch DIP switch No. 3 to **On**.

6.7 Ensuring the degree of protection

The measuring device fulfills all the requirements for degree of protection IP66/67, Type 4X enclosure.

To guarantee degree of protection IP66/67, Type 4X enclosure, carry out the following steps after the electrical connection:

1. Check that the housing seals are clean and fitted correctly.
2. Dry, clean or replace the seals if necessary.
3. Tighten all housing screws and screw covers.
4. Firmly tighten the cable glands.
5. To ensure that moisture does not enter the cable entry:
Route the cable so that it loops down before the cable entry ("water trap").

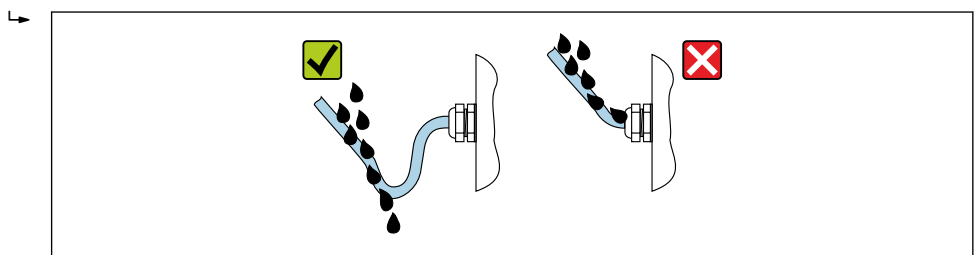

A0029278

6. Insert dummy plugs into unused cable entries.

6.7.1 Degree of protection IP68, Type 6P enclosure, with "Cust-potted" option

Depending on the version, the sensor meets all the requirements of IP68 degree of protection, Type 6P enclosure →  184 and can be used as a remote version .

The degree of protection of the transmitter is always only IP66/67, Type 4X enclosure and the transmitter must therefore be treated accordingly .

To guarantee IP68 degree of protection, Type 6P enclosure for the "Cust-potted" options, carry out the following steps after the electrical connection:

1. Firmly tighten the cable glands (torque: 2 to 3.5 Nm) until there is no gap between the bottom of the cover and the housing support surface.
2. Firmly tighten the union nut of the cable glands.
3. Pot the field housing with a potting compound.
4. Check that the housing seals are clean and fitted correctly. Dry, clean or replace the seals if necessary.
5. Tighten all housing screws and screw covers (torque: 20 to 30 Nm).

6.8 Post-connection check

Are cables or the device undamaged (visual inspection)?	<input type="checkbox"/>
Do the cables used meet the requirements ?	<input type="checkbox"/>
Do the cables have adequate strain relief?	<input type="checkbox"/>
Are all the cable glands installed, firmly tightened and leak-tight? Cable run with "water trap" →  47?	<input type="checkbox"/>

7 Operation options

7.1 Overview of operation options

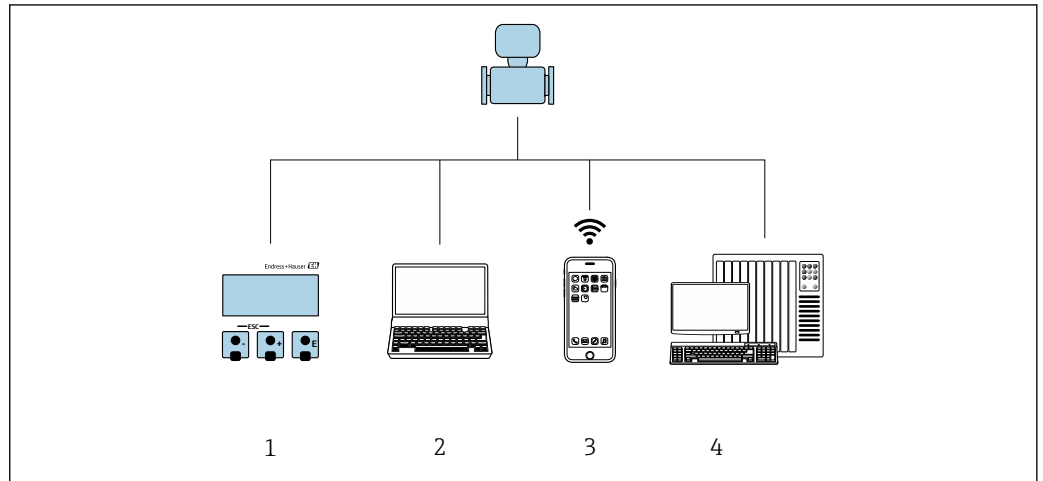

A0030213

- 1 Local operation via display module
- 2 Computer with Web browser (e.g. Internet Explorer) or with operating tool (e.g. FieldCare, DeviceCare, AMS Device Manager, SIMATIC PDM)
- 3 Mobile handheld terminal with SmartBlue App
- 4 Control system (e.g. PLC)

7.2 Structure and function of the operating menu

7.2.1 Structure of the operating menu

 For an overview of the operating menu for experts: "Description of Device Parameters" document supplied with the device

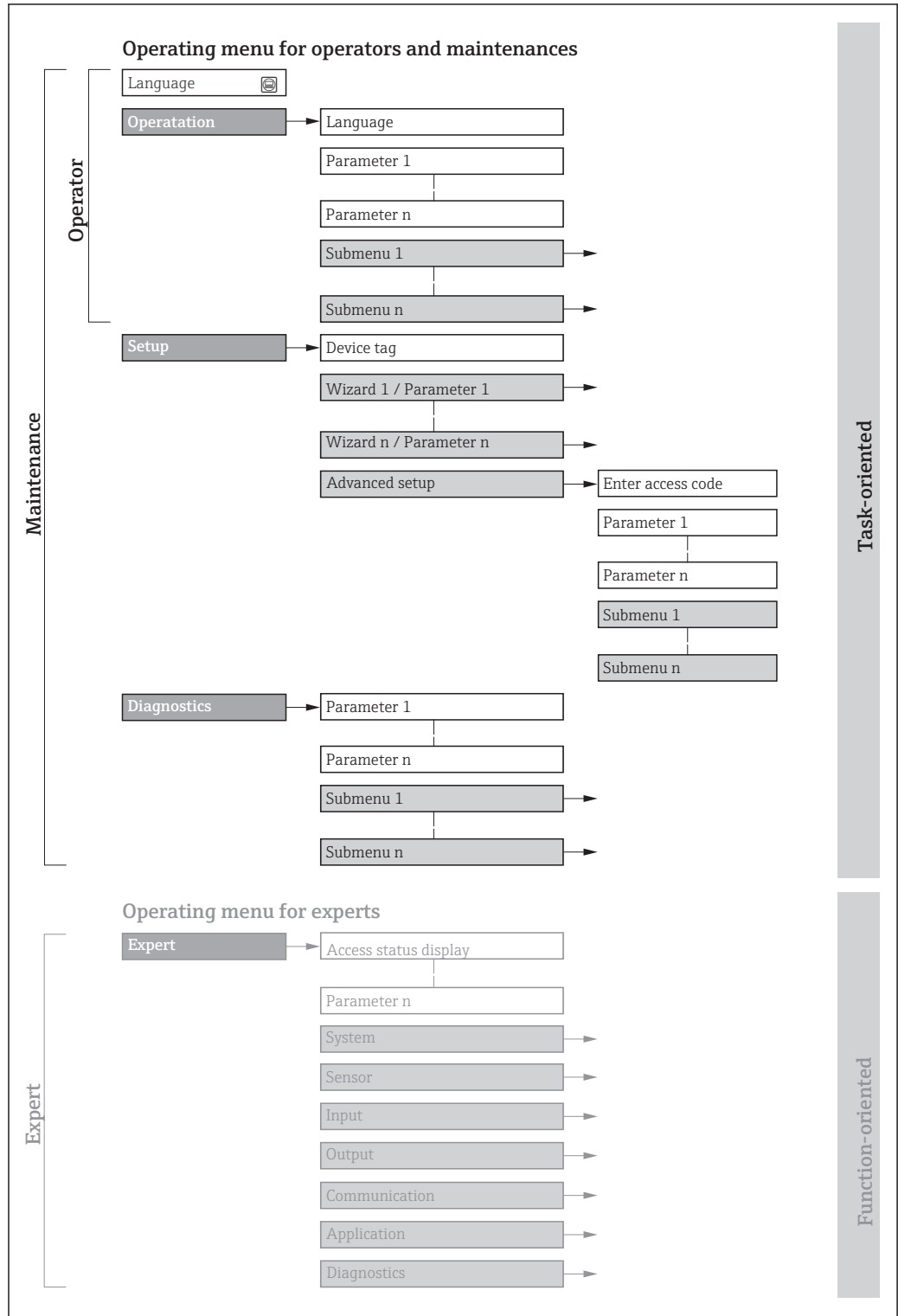

A0018237-EN

 27 Schematic structure of the operating menu

7.2.2 Operating philosophy

The individual parts of the operating menu are assigned to certain user roles (operator, maintenance etc.). Each user role contains typical tasks within the device lifecycle.

Menu/parameter		User role and tasks	Content/meaning
Language	task-oriented	Role "Operator", "Maintenance" Tasks during operation: <ul style="list-style-type: none"> ▪ Configuring the operational display ▪ Reading measured values 	<ul style="list-style-type: none"> ▪ Defining the operating language ▪ Defining the Web server operating language ▪ Resetting and controlling totalizers
Operation			<ul style="list-style-type: none"> ▪ Configuring the operational display (e.g. display format, display contrast) ▪ Resetting and controlling totalizers
Setup		"Maintenance" role Commissioning: <ul style="list-style-type: none"> ▪ Configuration of the measurement ▪ Configuration of the inputs and outputs ▪ Configuration of the communication interface 	Wizards for fast commissioning: <ul style="list-style-type: none"> ▪ Setting the system units ▪ Displaying the I/O/configuration ▪ Configuring the inputs ▪ Configuring the outputs ▪ Configuration of the operational display ▪ Setting the low flow cut off Advanced setup <ul style="list-style-type: none"> ▪ For more customized configuration of the measurement (adaptation to special measuring conditions) ▪ Configuration of totalizers ▪ Configuring the WLAN settings ▪ Administration (define access code, reset measuring device)
Diagnostics		"Maintenance" role Fault elimination: <ul style="list-style-type: none"> ▪ Diagnostics and elimination of process and device errors ▪ Measured value simulation 	Contains all parameters for error detection and analyzing process and device errors: <ul style="list-style-type: none"> ▪ Diagnostic list Contains up to 5 currently pending diagnostic messages. ▪ Event logbook Contains event messages that have occurred. ▪ Device information Contains information for identifying the device. ▪ Measured values Contains all current measured values. ▪ Data logging submenu with "Extended HistoROM" order option Storage and visualization of measured values ▪ Heartbeat The functionality of the device is checked on demand and the verification results are documented. ▪ Simulation Is used to simulate measured values or output values.
Expert	function-oriented	Tasks that require detailed knowledge of the function of the device: <ul style="list-style-type: none"> ▪ Commissioning measurements under difficult conditions ▪ Optimal adaptation of the measurement to difficult conditions ▪ Detailed configuration of the communication interface ▪ Error diagnostics in difficult cases 	Contains all the parameters of the device and makes it possible to access these parameters directly using an access code. The structure of this menu is based on the function blocks of the device: <ul style="list-style-type: none"> ▪ System Contains all higher-order device parameters which do not concern the measurement or the communication interface. ▪ Sensor Configuration of the measurement. ▪ Input Configuration of the status input. ▪ Output Configuration of the analog current outputs as well as the pulse/frequency and switch output. ▪ Communication Configuration of the digital communication interface and the Web server. ▪ Application Configuration of the functions that go beyond the actual measurement (e.g. totalizer). ▪ Diagnostics Error detection and analysis of process and device errors and for device simulation and Heartbeat Technology.

7.3 Access to the operating menu via the local display

7.3.1 Operational display

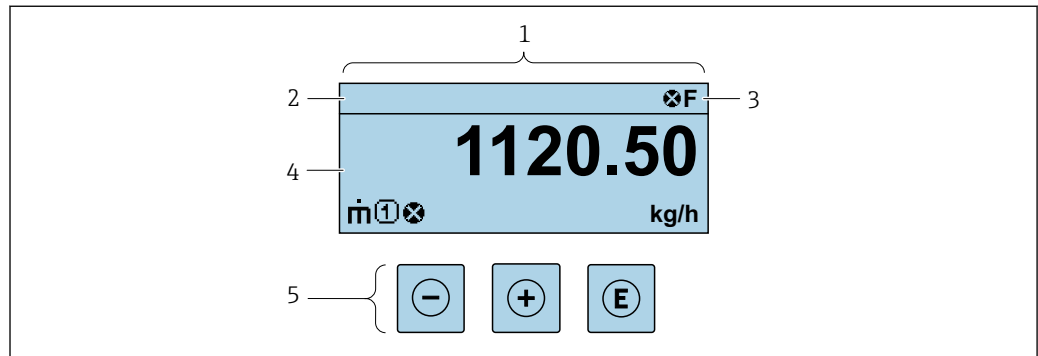

A0029348

- 1 Operational display
- 2 Device tag
- 3 Status area
- 4 Display area for measured values (4-line)
- 5 Operating elements → 57

Status area

The following symbols appear in the status area of the operational display at the top right:

- Status signals → 147
 - **F**: Failure
 - **C**: Function check
 - **S**: Out of specification
 - **M**: Maintenance required
- Diagnostic behavior → 148
 - : Alarm
 - : Warning
 - : Locking (the device is locked via the hardware)
 - : Communication (communication via remote operation is active)

Display area

In the display area, each measured value is prefaced by certain symbol types for further description:

	Measured variable	Measurement channel number	Diagnostic behavior
	↓	↓	↓
Example			

Appears only if a diagnostics event is present for this measured variable.

Measured variables

Symbol	Meaning
	Mass flow
	<ul style="list-style-type: none"> ▪ Volume flow ▪ Corrected volume flow ▪ FAD volume flow

\dot{Q}	Heat flow
ρ	<ul style="list-style-type: none"> ▪ Density ▪ Reference density
P	Energy flow
v	Flow velocity
H	Calorific value
	Temperature
Σ	Totalizer The measurement channel number indicates which of the three totalizers is displayed.
	Output The measurement channel number indicates which of the outputs is displayed.
	Status input

Measurement channel numbers

Symbol	Meaning
	Measurement channel 1 to 4

The measurement channel number is displayed only if more than one channel is present for the same measured variable type (e.g. Totalizer 1 to 3).

Diagnostic behavior

The diagnostic behavior pertains to a diagnostic event that is relevant to the displayed measured variable. For information on the symbols → 148



The number and display format of the measured values can be configured via the **Format display** parameter (→ 103).



7.3.2 Navigation view

In the submenu	In the wizard
<small>A0013993-EN</small>	<small>A00+1841-EN</small>
<p>1 Navigation view 2 Navigation path to current position 3 Status area 4 Display area for navigation 5 Operating elements → 57</p>	

Navigation path

The navigation path - displayed at the top left in the navigation view - consists of the following elements:



	<ul style="list-style-type: none"> In the submenu: Display symbol for menu In the wizard: Display symbol for wizard 	Omission symbol for operating menu levels in between	Name of current <ul style="list-style-type: none"> Submenu Wizard Parameters
	↓	↓	↓
Examples		/ .. /	Display
		/ .. /	Display

 For more information about the icons in the menu, refer to the "Display area" section →  54

Status area





The following appears in the status area of the navigation view in the top right corner:

- In the submenu
 - The direct access code for the parameter you are navigating to (e.g. 0022-1)
 - If a diagnostic event is present, the diagnostic behavior and status signal
- In the wizard
 - If a diagnostic event is present, the diagnostic behavior and status signal

-  For information on the diagnostic behavior and status signal →  147
- For information on the function and entry of the direct access code →  59



Display area

Menus

Symbol	Meaning
	Operation Appears: <ul style="list-style-type: none"> In the menu next to the "Operation" selection At the left in the navigation path in the Operation menu
	Setup Appears: <ul style="list-style-type: none"> In the menu next to the "Setup" selection At the left in the navigation path in the Setup menu
	Diagnostics Appears: <ul style="list-style-type: none"> In the menu next to the "Diagnostics" selection At the left in the navigation path in the Diagnostics menu
	Expert Appears: <ul style="list-style-type: none"> In the menu next to the "Expert" selection At the left in the navigation path in the Expert menu

Submenus, wizards, parameters



Symbol	Meaning
	Submenu

	Wizard
	Parameters within a wizard  No display symbol exists for parameters in submenus.

Locking

Symbol	Meaning
	Parameter locked When displayed in front of a parameter name, indicates that the parameter is locked. <ul style="list-style-type: none"> ▪ By a user-specific access code ▪ By the hardware write protection switch

Wizard operation

Symbol	Meaning
	Switches to the previous parameter.
	Confirms the parameter value and switches to the next parameter.
	Opens the editing view of the parameter.

7.3.3 Editing view

Numeric editor

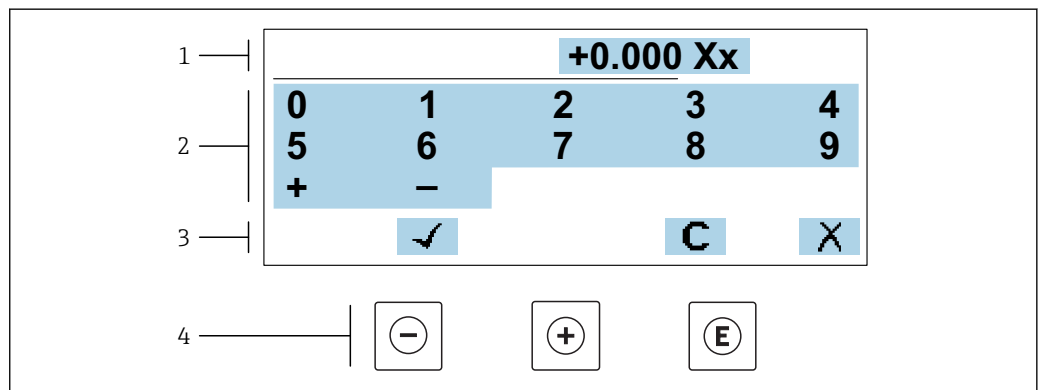

A0034250

 28 For entering values in parameters (e.g. limit values)

- 1 Entry display area
- 2 Input screen
- 3 Confirm, delete or reject entry
- 4 Operating elements

Text editor

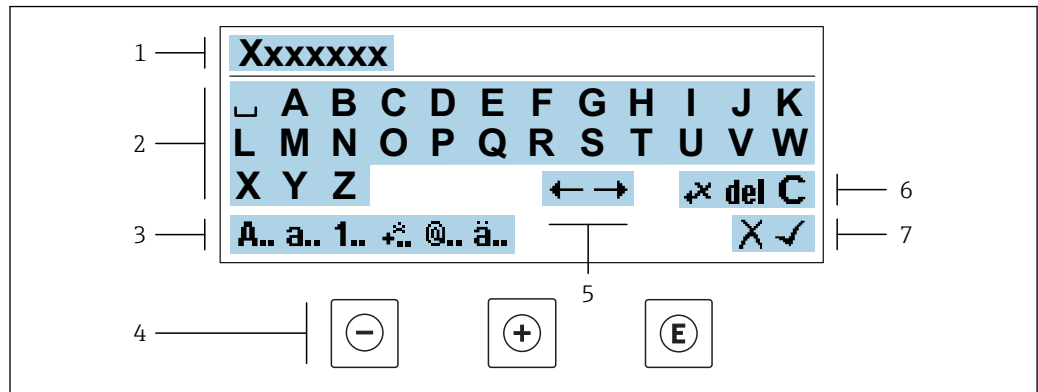

A0034114

29 For entering text in parameters (e.g. tag name)

- 1 Entry display area
- 2 Current input screen
- 3 Change input screen
- 4 Operating elements
- 5 Move entry position
- 6 Delete entry
- 7 Reject or confirm entry





Using the operating elements in the editing view

Operating key(s)	Meaning
	Minus key Move the entry position to the left.
	Plus key Move the entry position to the right.
	Enter key <ul style="list-style-type: none"> ▪ Press the key briefly: confirm your selection. ▪ Press the key for 2 s: confirm the entry.
	Escape key combination (press keys simultaneously) Close the editing view without accepting the changes.



Input screens





Symbol	Meaning
A..	Upper case
a..	Lower case
1..	Numbers
+*	Punctuation marks and special characters: = + - * / ² ³ ¼ ½ ¾ () [] < > { }
@..	Punctuation marks and special characters: " ^ . , ; : ? ! % μ ° € \$ £ ¥ \$ @ # / \ ~ & _
ä..	Umlauts and accents

Controlling data entries

Symbol	Meaning
	Move entry position
	Reject entry
	Confirm entry
	Delete character immediately to the left of the entry position
del	Delete character immediately to the right of the entry position
C	Clear all the characters entered

7.3.4 Operating elements

Operating key(s)	Meaning
	<p>Minus key</p> <p><i>In a menu, submenu</i> Moves the selection bar upwards in a picklist.</p> <p><i>With a Wizard</i> Confirms the parameter value and goes to the previous parameter.</p> <p><i>With a text and numeric editor</i> Move the entry position to the left.</p>
	<p>Plus key</p> <p><i>In a menu, submenu</i> Moves the selection bar downwards in a picklist.</p> <p><i>With a Wizard</i> Confirms the parameter value and goes to the next parameter.</p> <p><i>With a text and numeric editor</i> Move the entry position to the right.</p>
	<p>Enter key</p> <p><i>For operational display</i> Pressing the key briefly opens the operating menu.</p> <p><i>In a menu, submenu</i></p> <ul style="list-style-type: none"> ▪ Pressing the key briefly: <ul style="list-style-type: none"> ▪ Opens the selected menu, submenu or parameter. ▪ Starts the wizard. ▪ If help text is open, closes the help text of the parameter. ▪ Pressing the key for 2 s for parameter: <ul style="list-style-type: none"> ▪ If present, opens the help text for the function of the parameter. <p><i>With a Wizard</i> Opens the editing view of the parameter.</p> <p><i>With a text and numeric editor</i></p> <ul style="list-style-type: none"> ▪ Press the key briefly: confirm your selection. ▪ Press the key for 2 s: confirm the entry.

Operating key(s)	Meaning
 + 	<p>Escape key combination (press keys simultaneously)</p> <p><i>In a menu, submenu</i></p> <ul style="list-style-type: none"> Pressing the key briefly: <ul style="list-style-type: none"> Exits the current menu level and takes you to the next higher level. If help text is open, closes the help text of the parameter. Pressing the key for 2 s returns you to the operational display ("home position"). <p><i>With a Wizard</i> Exits the wizard and takes you to the next higher level.</p> <p><i>With a text and numeric editor</i> Close the editing view without accepting the changes.</p>
 + 	<p>Minus/Enter key combination (press the keys simultaneously)</p> <ul style="list-style-type: none"> If the keypad lock is active: Press the key for 3 s: deactivate the keypad lock. If the keypad lock is not active: Press the key for 3 s: the context menu opens along with the option for activating the keypad lock.



7.3.5 Opening the context menu

Using the context menu, the user can call up the following menus quickly and directly from the operational display:

- Setup
- Data backup
- Simulation



Calling up and closing the context menu

The user is in the operational display.

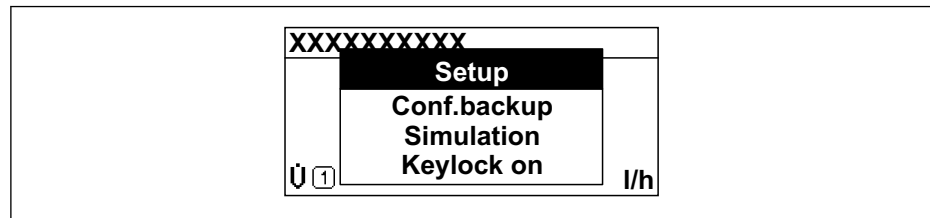

1. Press the  and  keys for longer than 3 seconds.
 - ↳ The context menu opens.



A0034608-EN

2. Press  +  simultaneously.
 - ↳ The context menu is closed and the operational display appears.

Calling up the menu via the context menu

1. Open the context menu.
2. Press  to navigate to the desired menu.
3. Press  to confirm the selection.
 - ↳ The selected menu opens.

7.3.6 Navigating and selecting from list

Different operating elements are used to navigate through the operating menu. The navigation path is displayed on the left in the header. Icons are displayed in front of the individual menus. These icons are also shown in the header during navigation.

i For an explanation of the navigation view with symbols and operating elements → 53

Example: Setting the number of displayed measured values to "2 values"

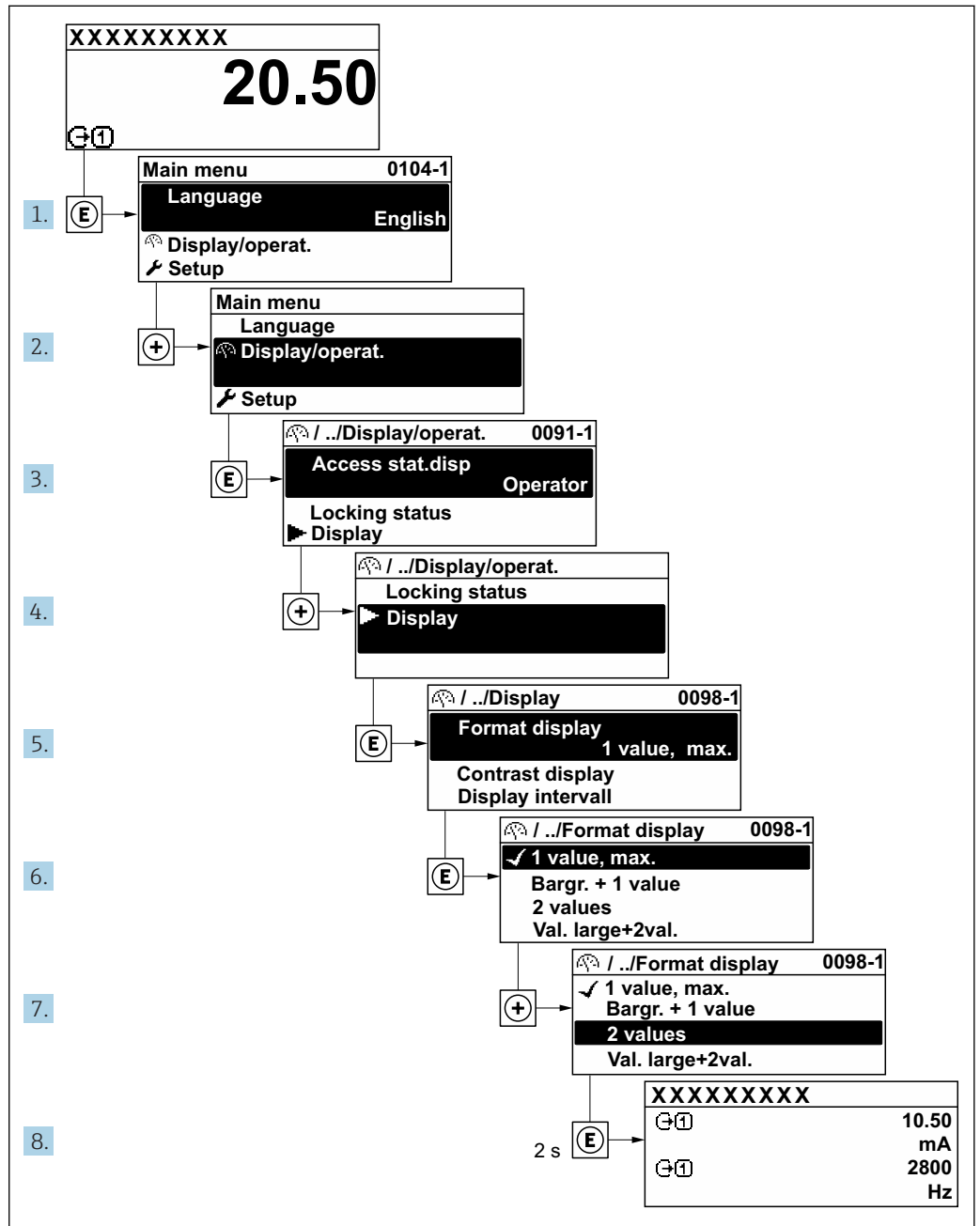

A0029562-EN

7.3.7 Calling the parameter directly

A parameter number is assigned to every parameter to be able to access a parameter directly via the onsite display. Entering this access code in the **Direct access** parameter calls up the desired parameter directly.

Navigation path

Expert → Direct access

The direct access code consists of a 5-digit number (at maximum) and the channel number, which identifies the channel of a process variable: e.g. 00914-2. In the navigation view, this appears on the right-hand side in the header of the selected parameter.

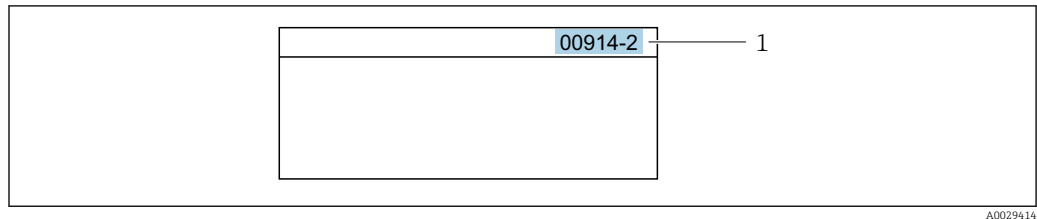

1 Direct access code

Note the following when entering the direct access code:

- The leading zeros in the direct access code do not have to be entered.
Example: Enter "914" instead of "00914"
- If no channel number is entered, channel 1 is accessed automatically.
Example: Enter 00914 → **Assign process variable** parameter
- If a different channel is accessed: Enter the direct access code with the corresponding channel number.
Example: Enter 00914-2 → **Assign process variable** parameter



For the direct access codes of the individual parameters, see the "Description of Device Parameters" document for the device

7.3.8 Calling up help text

Help text is available for some parameters and can be called up from the navigation view. The help text provides a brief explanation of the parameter function and thereby supports swift and safe commissioning.

Calling up and closing the help text

The user is in the navigation view and the selection bar is on a parameter.

1. Press **Enter** for 2 s.
↳ The help text for the selected parameter opens.

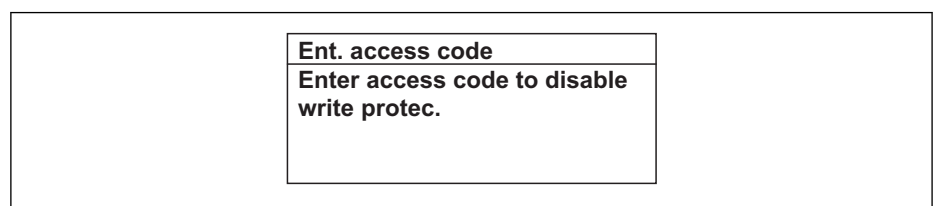

30 Example: Help text for parameter "Enter access code"

2. Press **Esc** + **Enter** simultaneously.
↳ The help text is closed.

7.3.9 Changing the parameters

Parameters can be changed via the numeric editor or text editor.

- Numeric editor: Change values in a parameter, e.g. specifications for limit values.
- Text editor: Enter text in a parameter, e.g. tag name.

A message is displayed if the value entered is outside the permitted value range.

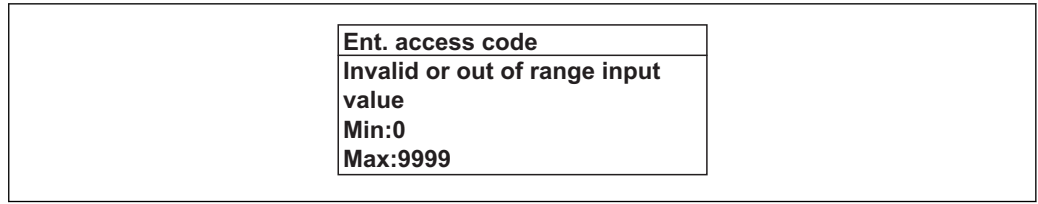

A0014049-EN

For a description of the editing view - consisting of the text editor and numeric editor - with symbols → 55, for a description of the operating elements → 57

7.3.10 User roles and related access authorization

The two user roles "Operator" and "Maintenance" have different write access to the parameters if the customer defines a user-specific access code. This protects the device configuration via the local display from unauthorized access → 127.

Defining access authorization for user roles

An access code is not yet defined when the device is delivered from the factory. Access authorization (read and write access) to the device is not restricted and corresponds to the "Maintenance" user role.

- ▶ Define the access code.
 - ↳ The "Operator" user role is redefined in addition to the "Maintenance" user role. Access authorization differs for the two user roles.

Access authorization to parameters: "Maintenance" user role

Access code status	Read access	Write access
An access code has not yet been defined (factory setting).	✓	✓
After an access code has been defined.	✓	✓ ¹⁾

1) The user only has write access after entering the access code.

Access authorization to parameters: "Operator" user role

Access code status	Read access	Write access
After an access code has been defined.	✓	-- ¹⁾

1) Despite the defined access code, certain parameters can always be modified and thus are exempted from the write protection, as they do not affect the measurement. Refer to the "Write protection via access code" section

The user role with which the user is currently logged on is indicated by the **Access status** parameter. Navigation path: Operation → Access status

7.3.11 Disabling write protection via access code

If the -symbol appears on the local display in front of a parameter, the parameter is write-protected by a user-specific access code and its value cannot be changed at the moment using local operation → 127.

Parameter write protection via local operation can be disabled by entering the user-specific access code in the **Enter access code** parameter (→ 107) via the respective access option.

1. After you press , the input prompt for the access code appears.

2. Enter the access code.
 - ↳ The -symbol in front of the parameters disappears; all previously write-protected parameters are now re-enabled.

7.3.12 Enabling and disabling the keypad lock



The keypad lock makes it possible to block access to the entire operating menu via local operation. As a result, it is no longer possible to navigate through the operating menu or change the values of individual parameters. Users can only read the measured values on the operational display.

The keypad lock is switched on and off via the context menu.

Switching on the keypad lock



-  The keypad lock is switched on automatically:
- If the device has not been operated via the display for > 1 minute.
 - Each time the device is restarted.

To activate the keylock manually:

1. The device is in the measured value display.
Press the  and  keys for 3 seconds.
 - ↳ A context menu appears.
2. In the context menu select the **Keylock on** option.
 - ↳ The keypad lock is switched on.

-  If the user attempts to access the operating menu while the keypad lock is active, the **Keylock on** message appears.

Switching off the keypad lock

- ▶ The keypad lock is switched on.
Press the  and  keys for 3 seconds.
 - ↳ The keypad lock is switched off.

7.4 Access to the operating menu via the Web browser

7.4.1 Function range

Thanks to the integrated Web server, the device can be operated and configured via a Web browser and via a service interface (CDI-RJ45) or via a WLAN interface. The structure of the operating menu is the same as for the local display. In addition to the measured values, status information on the device is also displayed and allows the user to monitor the status of the device. Furthermore the device data can be managed and the network parameters can be configured.

A device that has a WLAN interface (can be ordered as an option) is required for the WLAN connection: order code for "Display; operation", option G "4-line, illuminated; touch control + WLAN". The device acts as an Access Point and enables communication by computer or a mobile handheld terminal.



-  For additional information on the Web server, refer to the Special Documentation for the device

7.4.2 Prerequisites



Computer hardware

Hardware	Interface	
	CDI-RJ45	WLAN
Interface	The computer must have an RJ45 interface.	The operating unit must have a WLAN interface.
Connection	Standard Ethernet cable with RJ45 connector.	Connection via Wireless LAN.
Screen	Recommended size: ≥ 12" (depends on the screen resolution)	

Computer software

Software	Interface	
	CDI-RJ45	WLAN
Recommended operating systems	<ul style="list-style-type: none"> ▪ Microsoft Windows 8 or higher. ▪ Mobile operating systems: <ul style="list-style-type: none"> ▪ iOS ▪ Android  Microsoft Windows XP is supported.  Microsoft Windows 7 is supported. 	
Web browsers supported	<ul style="list-style-type: none"> ▪ Microsoft Internet Explorer 8 or higher ▪ Microsoft Edge ▪ Mozilla Firefox ▪ Google Chrome ▪ Safari 	

Computer settings

Settings	Interface	
	CDI-RJ45	WLAN
User rights	Appropriate user rights (e.g. administrator rights) for TCP/IP and proxy server settings are necessary (for adjusting the IP address, subnet mask etc.).	
Proxy server settings of the Web browser	The Web browser setting <i>Use a Proxy Server for Your LAN</i> must be deselected .	
JavaScript	JavaScript must be enabled.  If JavaScript cannot be enabled: enter <code>http://192.168.1.212/basic.html</code> in the address line of the Web browser. A fully functional but simplified version of the operating menu structure starts in the Web browser.  When installing a new firmware version: To enable correct data display, clear the temporary memory (cache) of the Web browser under Internet options .	
Network connections	Only the active network connections to the measuring device should be used.	
	Switch off all other network connections such as WLAN.	Switch off all other network connections.

 In the event of connection problems: →  143

Measuring device: Via CDI-RJ45 service interface

Device	CDI-RJ45 service interface
Measuring device	The measuring device has an RJ45 interface.
Web server	Web server must be enabled; factory setting: ON  For information on enabling the Web server → 68

Measuring device: via WLAN interface

Device	WLAN interface
Measuring device	The measuring device has a WLAN antenna: <ul style="list-style-type: none"> ▪ Transmitter with integrated WLAN antenna ▪ Transmitter with external WLAN antenna
Web server	Web server and WLAN must be enabled; factory setting: ON  For information on enabling the Web server → 68

7.4.3 Establishing a connection

Via service interface (CDI-RJ45)

Preparing the measuring device

Configuring the Internet protocol of the computer

The following information refers to the default Ethernet settings of the device.

IP address of the device: 192.168.1.212 (factory setting)

1. Switch on the measuring device.
2. Connect to the computer using a cable → 69.
3. If a 2nd network card is not used, close all the applications on the notebook.
 - ↳ Applications requiring Internet or a network, such as e-mail, SAP applications, Internet or Windows Explorer.
4. Close any open Internet browsers.
5. Configure the properties of the Internet protocol (TCP/IP) as defined in the table:

IP address	192.168.1.XXX; for XXX all numerical sequences except: 0, 212 and 255 → e.g. 192.168.1.213
Subnet mask	255.255.255.0
Default gateway	192.168.1.212 or leave cells empty

Via WLAN interface

Configuring the Internet protocol of the mobile terminal

NOTICE

If the WLAN connection is lost during the configuration, settings made may be lost.

- ▶ Make sure that the WLAN connection is not disconnected while configuring the device.

NOTICE

In principle, avoid simultaneous access to the measuring device via the service interface (CDI-RJ45) and the WLAN interface from the same mobile terminal. This could cause a network conflict.

- ▶ Only activate one service interface (CDI-RJ45 service interface or WLAN interface).
- ▶ If simultaneous communication is necessary: configure different IP address ranges, e.g. 192.168.0.1 (WLAN interface) and 192.168.1.212 (CDI-RJ45 service interface).

Preparing the mobile terminal

- ▶ Enable WLAN reception on the mobile terminal.

Establishing a connection from the mobile terminal to the measuring device

1. In the WLAN settings of the mobile terminal:
Select the measuring device using the SSID (e.g. EH_t-mass_500_A802000).
2. If necessary, select the WPA2 encryption method.
3. Enter the password: serial number of the measuring device ex-works (e.g. L100A802000).
 - ↳ LED on display module flashes: it is now possible to operate the measuring device with the Web browser, FieldCare or DeviceCare.

 The serial number can be found on the nameplate.

 To ensure the safe and swift assignment of the WLAN network to the measuring point, it is advisable to change the SSID name. It should be possible to clearly assign the new SSID name to the measuring point (e.g. tag name) because it is displayed as the WLAN network.

Disconnecting

- ▶ After configuring the device:
Terminate the WLAN connection between the operating unit and measuring device.

Starting the Web browser

1. Start the Web browser on the computer.

2. Enter the IP address of the Web server in the address line of the Web browser:
192.168.1.212
↳ The login page appears.

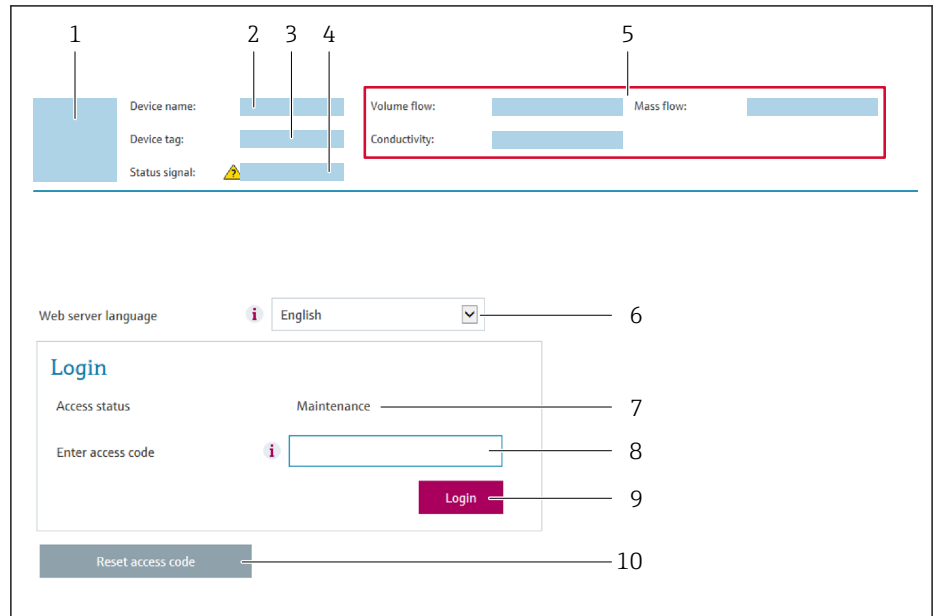

A0029417

- 1 Picture of device
- 2 Device name
- 3 Device tag (→ 81)
- 4 Status signal
- 5 Current measured values
- 6 Operating language
- 7 User role
- 8 Access code
- 9 Login
- 10 Reset access code (→ 117)

i If a login page does not appear, or if the page is incomplete → 143

7.4.4 Logging on

1. Select the preferred operating language for the Web browser.
2. Enter the user-specific access code.
3. Press **OK** to confirm your entry.

Access code	0000 (factory setting); can be changed by customer
-------------	--

i If no action is performed for 10 minutes, the Web browser automatically returns to the login page.

7.4.5 User interface

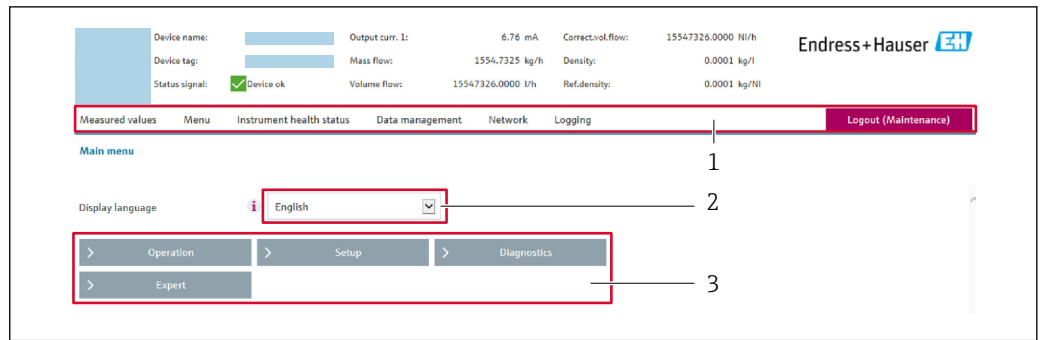

A0029418

- 1 Function row
- 2 Local display language
- 3 Navigation area

Header

The following information appears in the header:

- Device name
- Device tag
- Device status with status signal → 📄 150
- Current measured values

Function row

Functions	Meaning
Measured values	Displays the measured values of the measuring device
Menu	<ul style="list-style-type: none"> ■ Access to the operating menu from the measuring device ■ The structure of the operating menu is the same as for the local display For detailed information on the structure of the operating menu, see the Operating Instructions for the measuring device
Device status	Displays the diagnostic messages currently pending, listed in order of priority
Data management	Data exchange between PC and measuring device: <ul style="list-style-type: none"> ■ Device configuration: <ul style="list-style-type: none"> ■ Load settings from the device (XML format, save configuration) ■ Save settings to the device (XML format, restore configuration) ■ Logbook - Export Event logbook (.csv file) ■ Documents - Export documents: <ul style="list-style-type: none"> ■ Export backup data record (.csv file, create documentation of the measuring point configuration) ■ Verification report (PDF file, only available with the "Heartbeat Verification" application package) ■ Firmware update - Flashing a firmware version
Network configuration	Configuration and checking of all the parameters required for establishing the connection to the measuring device: <ul style="list-style-type: none"> ■ Network settings (e.g. IP address, MAC address) ■ Device information (e.g. serial number, firmware version)
Logout	End the operation and call up the login page

Navigation area

If a function is selected in the function bar, the submenus of the function open in the navigation area. The user can now navigate through the menu structure.

Working area

Depending on the selected function and the related submenus, various actions can be performed in this area:

- Configuring parameters
- Reading measured values
- Calling up help text
- Starting an upload/download

7.4.6 Disabling the Web server

The Web server of the measuring device can be switched on and off as required using the **Web server functionality** parameter.

Navigation

"Expert" menu → Communication → Web server

Parameter overview with brief description

Parameter	Description	Selection	Factory setting
Web server functionality	Switch the Web server on and off.	<ul style="list-style-type: none"> ▪ Off ▪ HTML Off ▪ On 	On

Function scope of the "Web server functionality" parameter

Option	Description
Off	<ul style="list-style-type: none"> ▪ The web server is completely disabled. ▪ Port 80 is locked.
On	<ul style="list-style-type: none"> ▪ The complete functionality of the web server is available. ▪ JavaScript is used. ▪ The password is transferred in an encrypted state. ▪ Any change to the password is also transferred in an encrypted state.

Enabling the Web server

If the Web server is disabled it can only be re-enabled with the **Web server functionality** parameter via the following operating options:

- Via local display
- Via Bedientool "FieldCare"
- Via "DeviceCare" operating tool

7.4.7 Logging out

 Before logging out, perform a data backup via the **Data management** function (upload configuration from device) if necessary.

1. Select the **Logout** entry in the function row.
↳ The home page with the Login box appears.
2. Close the Web browser.
3. If no longer needed:
Reset modified properties of the Internet protocol (TCP/IP) →  64.

7.5 Access to the operating menu via the operating tool

The structure of the operating menu in the operating tools is the same as for operation via the local display.

7.5.1 Connecting the operating tool

Via Modbus RS485 protocol

This communication interface is available in device versions with a Modbus-RS485 output.

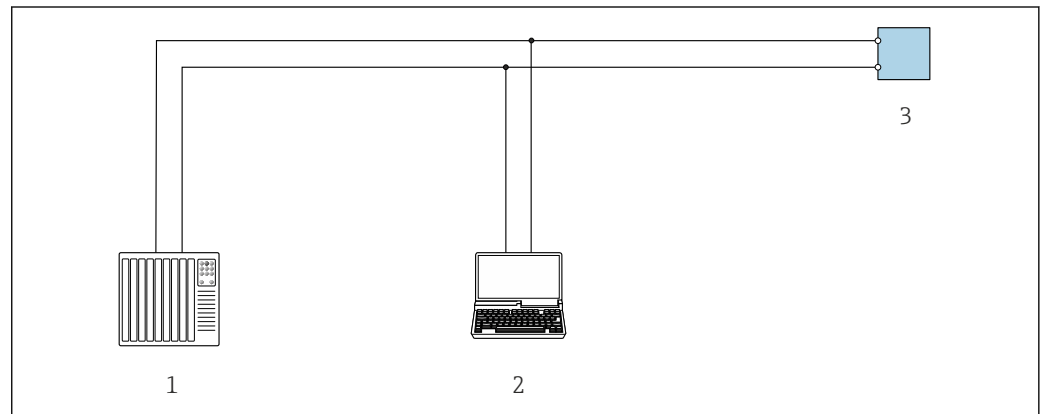

31 Options for remote operation via Modbus-RS485 protocol (active)

- 1 Control system (e.g. PLC)
- 2 Computer with Web browser (e.g. Internet Explorer) for accessing the integrated device Web server or with operating tool (e.g. FieldCare, DeviceCare) with COM DTM "CDI Communication TCP/IP" or Modbus DTM
- 3 Transmitter

Service interface

Via service interface (CDI-RJ45)

A point-to-point connection can be established to configure the device onsite. With the housing open, the connection is established directly via the service interface (CDI-RJ45) of the device.

i An adapter for RJ45 and the M12 connector is optionally available:
Order code for "Accessories", option **NB**: "Adapter RJ45 M12 (service interface)"

The adapter connects the service interface (CDI-RJ45) to an M12 connector mounted in the cable entry. Therefore the connection to the service interface can be established via an M12 connector without opening the device.

Proline 500 – digital transmitter

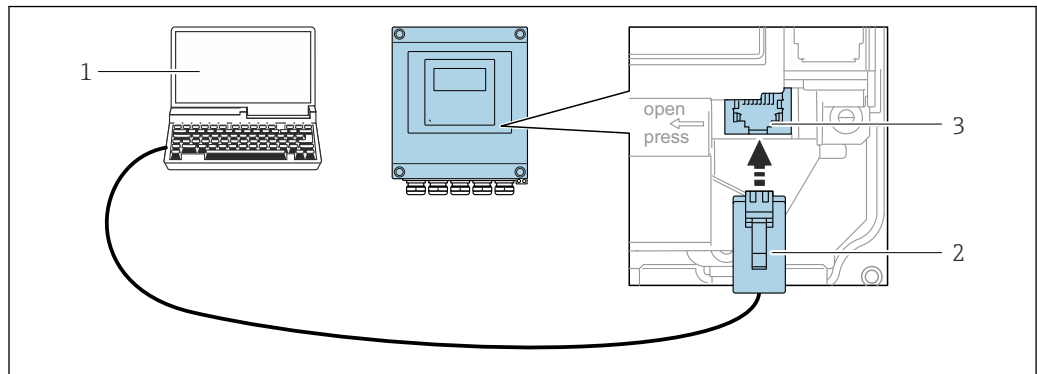

32 Connection via service interface (CDI-RJ45)

- 1 Computer with Web browser (e.g. Microsoft Internet Explorer, Microsoft Edge) for accessing the integrated device Web server or with "FieldCare", "DeviceCare" operating tool with COM DTM "CDI Communication TCP/IP" or Modbus DTM
- 2 Standard Ethernet connecting cable with RJ45 connector
- 3 Service interface (CDI-RJ45) of the measuring device with access to the integrated Web server

Via WLAN interface

The optional WLAN interface is available on the following device version:

Order code for "Display; operation", option G "4-line, illuminated; touch control + WLAN"

Function	WLAN: IEEE 802.11 b/g (2.4 GHz)
Encryption	WPA2-PSK AES-128 (in accordance with IEEE 802.11i)
Configurable WLAN channels	1 to 11
Degree of protection	IP67
Available antennas	<ul style="list-style-type: none"> ▪ Internal antenna ▪ External antenna (optional) In the event of poor transmission/reception conditions at the place of installation. <p> Only one antenna active in each case!</p>
Range	<ul style="list-style-type: none"> ▪ Internal antenna: typically 10 m (32 ft) ▪ External antenna: typically 50 m (164 ft)
Materials (external antenna)	<ul style="list-style-type: none"> ▪ Antenna: ASA plastic (acrylic ester-styrene-acrylonitrile) and nickel-plated brass ▪ Adapter: Stainless steel and nickel-plated brass ▪ Cable: Polyethylene ▪ Connector: Nickel-plated brass ▪ Angle bracket: Stainless steel

Configuring the Internet protocol of the mobile terminal

NOTICE

If the WLAN connection is lost during the configuration, settings made may be lost.

- ▶ Make sure that the WLAN connection is not disconnected while configuring the device.

NOTICE

In principle, avoid simultaneous access to the measuring device via the service interface (CDI-RJ45) and the WLAN interface from the same mobile terminal. This could cause a network conflict.

- ▶ Only activate one service interface (CDI-RJ45 service interface or WLAN interface).
- ▶ If simultaneous communication is necessary: configure different IP address ranges, e.g. 192.168.0.1 (WLAN interface) and 192.168.1.212 (CDI-RJ45 service interface).

Preparing the mobile terminal

- ▶ Enable WLAN reception on the mobile terminal.

Establishing a connection from the mobile terminal to the measuring device

1. In the WLAN settings of the mobile terminal:
Select the measuring device using the SSID (e.g. EH_t-mass_500_A802000).
2. If necessary, select the WPA2 encryption method.
3. Enter the password: serial number of the measuring device ex-works (e.g. L100A802000).
 - ↳ LED on display module flashes: it is now possible to operate the measuring device with the Web browser, FieldCare or DeviceCare.

 The serial number can be found on the nameplate.

 To ensure the safe and swift assignment of the WLAN network to the measuring point, it is advisable to change the SSID name. It should be possible to clearly assign the new SSID name to the measuring point (e.g. tag name) because it is displayed as the WLAN network.



Disconnecting

- ▶ After configuring the device:
Terminate the WLAN connection between the operating unit and measuring device.

7.5.2 FieldCare**Function scope**

FDT-based plant asset management tool from Endress+Hauser. It can configure all smart field devices in a system and helps you manage them. By using the status information, it is also a simple but effective way of checking their status and condition.

Access is via:

- CDI-RJ45 service interface →  69
- WLAN interface →  70

Typical functions:

- Configuring parameters of transmitters
- Loading and saving device data (upload/download)
- Documentation of the measuring point
- Visualization of the measured value memory (line recorder) and event logbook

 For additional information about FieldCare, see Operating Instructions BA00027S and BA00059S

Source for device description files

See information →  73

Establishing a connection

 For additional information, see Operating Instructions BA00027S and BA00059S

User interface

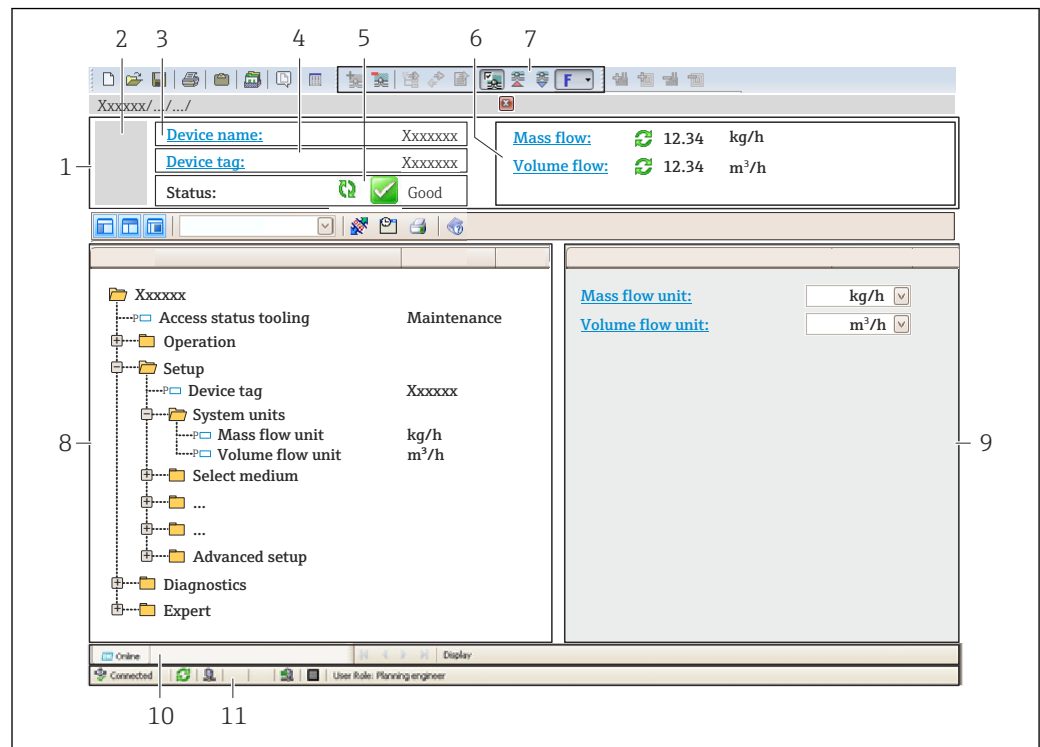

A0021051-EN

- 1 Header
- 2 Picture of device
- 3 Device name
- 4 Device tag
- 5 Status area with status signal → 150
- 6 Display area for current measured values
- 7 Edit toolbar with additional functions such as save/restore, event list and create documentation
- 8 Navigation area with operating menu structure
- 9 Working area
- 10 Range of action
- 11 Status area

7.5.3 DeviceCare

Function scope

Tool to connect and configure Endress+Hauser field devices.

The fastest way to configure Endress+Hauser field devices is with the dedicated "DeviceCare" tool. Together with the device type managers (DTMs) it presents a convenient, comprehensive solution.

 For details, see Innovation Brochure IN01047S

Source for device description files

See information → 73

8 System integration

8.1 Overview of device description files

8.1.1 Current version data for the device

Firmware version	01.05.zz	<ul style="list-style-type: none"> ▪ On the title page of the Operating Instructions ▪ On the transmitter nameplate ▪ Firmware version Diagnostics → Device information → Firmware version
Release date of firmware version	08.2019	---



For an overview of the different firmware versions for the device → 161

8.1.2 Operating tools

The suitable device description file for the individual operating tools is listed in the table below, along with information on where the file can be acquired.

Operating tool via service interface (CDI) or Modbus interface	Sources for obtaining device descriptions
FieldCare	<ul style="list-style-type: none"> ▪ www.endress.com → Download Area ▪ CD-ROM (contact Endress+Hauser) ▪ DVD (contact Endress+Hauser)
DeviceCare	<ul style="list-style-type: none"> ▪ www.endress.com → Download Area ▪ CD-ROM (contact Endress+Hauser) ▪ DVD (contact Endress+Hauser)

8.2 Compatibility with earlier model



If the device is replaced, the measuring device 500 supports the compatibility of the Modbus registers for the process variables and the diagnostic information with the previous model. It is not necessary to change the engineering parameters in the automation system.

Compatible Modbus registers: process variables

Process variable	Compatible Modbus registers
Mass flow	2007
Volume flow	2009
Totalizer 1	2610
Totalizer 2	2810
Totalizer 3	3010

Compatible Modbus registers: diagnostic information



Diagnostic information	Compatible Modbus registers
Diagnostic code (data type: String), e.g. F270	6821
Diagnostic number (data type: Integer), e.g. 270	6859



 The Modbus registers are compatible but the diagnostic numbers are not. Overview of the new diagnostic numbers →  153.

8.3 Modbus RS485 information

8.3.1 Function codes

Function codes are used to define which read or write action is carried out via the Modbus protocol. The measuring device supports the following function codes:

Code	Name	Description	Application
03	Read holding register	<p>Master reads one or more Modbus registers from the device. A maximum of 125 consecutive registers can be read with 1 telegram: 1 register = 2 bytes</p> <p> The measuring device does not make a distinction between function codes 03 and 04; these codes therefore yield the same result.</p>	<p>Read device parameters with read and write access</p> <p>Example: Read mass flow</p>
04	Read input register	<p>Master reads one or more Modbus registers from the device. A maximum of 125 consecutive registers can be read with 1 telegram: 1 register = 2 bytes</p> <p> The measuring device does not make a distinction between function codes 03 and 04; these codes therefore yield the same result.</p>	<p>Read device parameters with read access</p> <p>Example: Read totalizer value</p>
06	Write single registers	<p>Master writes a new value to one Modbus register of the measuring device.</p> <p> Use function code 16 to write multiple registers with just 1 telegram.</p>	<p>Write only 1 device parameter</p> <p>Example: reset totalizer</p>
08	Diagnostics	<p>Master checks the communication connection to the measuring device. The following "Diagnostics codes" are supported:</p> <ul style="list-style-type: none"> ▪ Sub-function 00 = Return query data (loopback test) ▪ Sub-function 02 = Return diagnostics register 	

Code	Name	Description	Application
16	Write multiple registers	<p>Master writes a new value to multiple Modbus registers of the device. A maximum of 120 consecutive registers can be written with 1 telegram.</p> <p> If the required device parameters are not available as a group, yet must nevertheless be addressed with a single telegram, use Modbus data map →  76</p>	Write multiple device parameters
23	Read/Write multiple registers	<p>Master reads and writes a maximum of 118 Modbus registers of the measuring device simultaneously with 1 telegram. Write access is executed before read access.</p>	<p>Write and read multiple device parameters</p> <p>Example:</p> <ul style="list-style-type: none"> ▪ Read mass flow ▪ Reset totalizer

 Broadcast messages are only allowed with function codes 06, 16 and 23.

8.3.2 Register information

 For an overview of device parameters with their respective Modbus register information, please refer to the "Modbus RS485 register information" section in the "Description of device parameters" documentation .

8.3.3 Response time

Response time of the measuring device to the request telegram of the Modbus master: typically 3 to 5 ms

8.3.4 Data types

The measuring device supports the following data types:

FLOAT (floating point number IEEE 754) Data length = 4 bytes (2 registers)			
Byte 3	Byte 2	Byte 1	Byte 0
SEEEEEEE	EMMMMMMM	MMMMMMMM	MMMMMMMM
S = sign, E = exponent, M = mantissa			

INTEGER Data length = 2 bytes (1 register)	
Byte 1	Byte 0
Most significant byte (MSB)	Least significant byte (LSB)

STRING Data length = depends on the device parameter, e.g. presentation of a device parameter with a data length = 18 bytes (9 registers)				
Byte 17	Byte 16	...	Byte 1	Byte 0
Most significant byte (MSB)		...		Least significant byte (LSB)

8.3.5 Byte transmission sequence

Byte addressing, i.e. the transmission sequence of the bytes, is not specified in the Modbus specification. For this reason, it is important to coordinate or match the addressing method between the master and slave during commissioning. This can be configured in the measuring device using the **Byte order** parameter.

The bytes are transmitted depending on the selection in the **Byte order** parameter:

FLOAT				
	Sequence			
Options	1.	2.	3.	4.
1 - 0 - 3 - 2 *	Byte 1 (MMMMMMMM)	Byte 0 (MMMMMMMM)	Byte 3 (SEEEEEEE)	Byte 2 (EMMMMMMM)
0 - 1 - 2 - 3	Byte 0 (MMMMMMMM)	Byte 1 (MMMMMMMM)	Byte 2 (EMMMMMMM)	Byte 3 (SEEEEEEE)
2 - 3 - 0 - 1	Byte 2 (EMMMMMMM)	Byte 3 (SEEEEEEE)	Byte 0 (MMMMMMMM)	Byte 1 (MMMMMMMM)
3 - 2 - 1 - 0	Byte 3 (SEEEEEEE)	Byte 2 (EMMMMMMM)	Byte 1 (MMMMMMMM)	Byte 0 (MMMMMMMM)

* = factory setting, S = sign, E = exponent, M = mantissa

INTEGER		
	Sequence	
Options	1.	2.
1 - 0 - 3 - 2 * 3 - 2 - 1 - 0	Byte 1 (MSB)	Byte 0 (LSB)
0 - 1 - 2 - 3 2 - 3 - 0 - 1	Byte 0 (LSB)	Byte 1 (MSB)

* = factory setting, MSB = most significant byte, LSB = least significant byte

STRING					
Presentation taking the example of a device parameter with a data length of 18 bytes.					
	Sequence				
Options	1.	2.	...	17.	18.
1 - 0 - 3 - 2 * 3 - 2 - 1 - 0	Byte 17 (MSB)	Byte 16	...	Byte 1	Byte 0 (LSB)
0 - 1 - 2 - 3 2 - 3 - 0 - 1	Byte 16	Byte 17 (MSB)	...	Byte 0 (LSB)	Byte 1

* = factory setting, MSB = most significant byte, LSB = least significant byte

8.3.6 Modbus data map

Function of the Modbus data map

The device offers a special memory area, the Modbus data map (for a maximum of 16 device parameters), to allow users to call up multiple device parameters via Modbus RS485 and not only individual device parameters or a group of consecutive device parameters.

Grouping of device parameters is flexible and the Modbus master can read or write to the entire data block simultaneously with a single request telegram.

Structure of the Modbus data map

The Modbus data map consists of two data sets:

- **Scan list: Configuration area**
The device parameters to be grouped are defined in a list in that their Modbus RS485 register addresses are entered in the list.
- **Data area**
The measuring device reads out the register addresses entered in the scan list cyclically and writes the associated device data (values) to the data area.

 For an overview of device parameters with their respective Modbus register information, please refer to the "Modbus RS485 register information" section in the "Description of device parameters" documentation .

Scan list configuration

For configuration, the Modbus RS485 register addresses of the device parameters to be grouped must be entered in the scan list. Please note the following basic requirements of the scan list:

Max. entries	16 device parameters
Supported device parameters	Only parameters with the following characteristics are supported: <ul style="list-style-type: none"> ■ Access type: read or write access ■ Data type: float or integer

Configuring the scan list via FieldCare or DeviceCare

Carried out using the operating menu of the measuring device:
Expert → Communication → Modbus data map → Scan list register 0 to 15

Scan list	
No.	Configuration register
0	Scan list register 0
...	...
15	Scan list register 15

Configuring the scan list via Modbus RS485

Carried out using register addresses 5001 - 5016

Scan list			
No.	Modbus RS485 register	Data type	Configuration register
0	5001	Integer	Scan list register 0
...	...	Integer	...
15	5016	Integer	Scan list register 15

Reading out data via Modbus RS485

The Modbus master accesses the data area of the Modbus data map to read out the current values of the device parameters defined in the scan list.

Master access to data area	Via register addresses 5051-5081
-----------------------------------	----------------------------------

Data area				
Device parameter value	Modbus RS485 register		Data type*	Access**
	Start register	End register (Float only)		
Value of scan list register 0	5051	5052	Integer/float	Read/write
Value of scan list register 1	5053	5054	Integer/float	Read/write
Value of scan list register
Value of scan list register 15	5081	5082	Integer/float	Read/write

* Data type depends on the device parameters entered in the scan list.
** Data access depends on the device parameters entered in the scan list. If the device parameter entered supports read and write access, the parameter can also be accessed via the data area.

9 Commissioning

9.1 Function check

Before commissioning the measuring device:

- ▶ Make sure that the post-installation and post-connection checks have been performed.
- "Post-installation check" checklist → 📄 30
- "Post-connection check" checklist → 📄 48

9.2 Switching on the measuring device

- ▶ After a successful function check, switch on the measuring device.
 - ↳ After a successful startup, the local display switches automatically from the startup display to the operational display.

i If nothing appears on the local display or a diagnostic message is displayed, refer to the section on "Diagnostics and troubleshooting" → 📄 142.

9.3 Setting the operating language

Factory setting: English or ordered local language

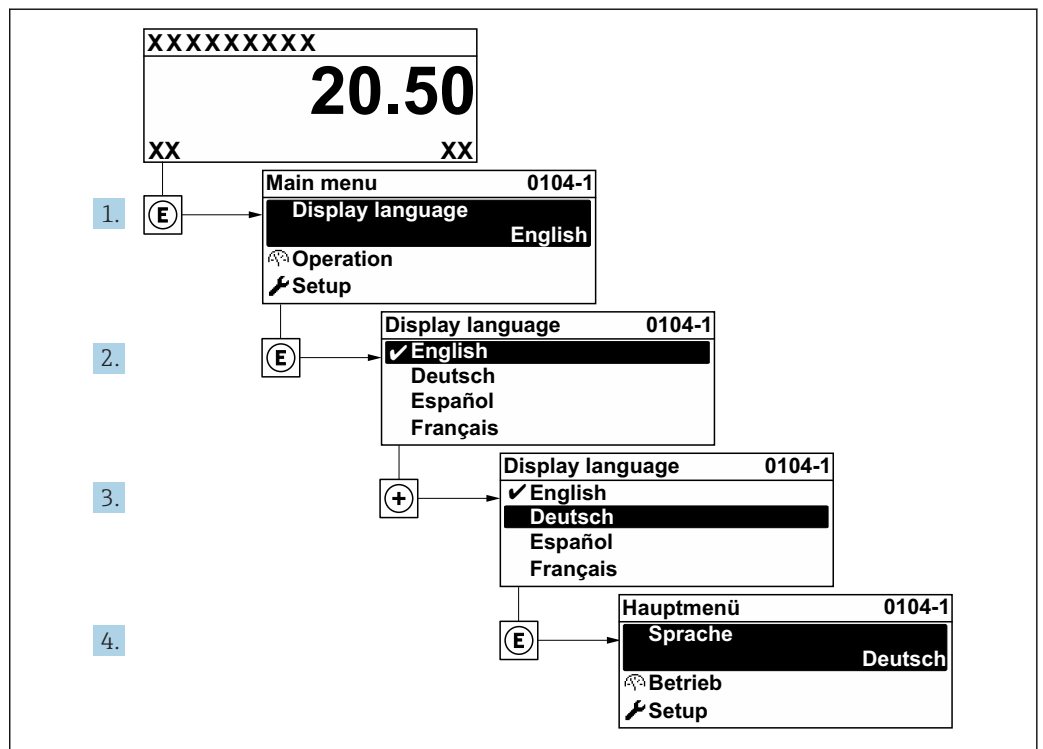

📄 33 Taking the example of the local display

A0029420

9.4 Configuring the measuring device

- The **Setup** menu with its guided wizards contains all the parameters needed for standard operation.
- Navigation to the **Setup** menu

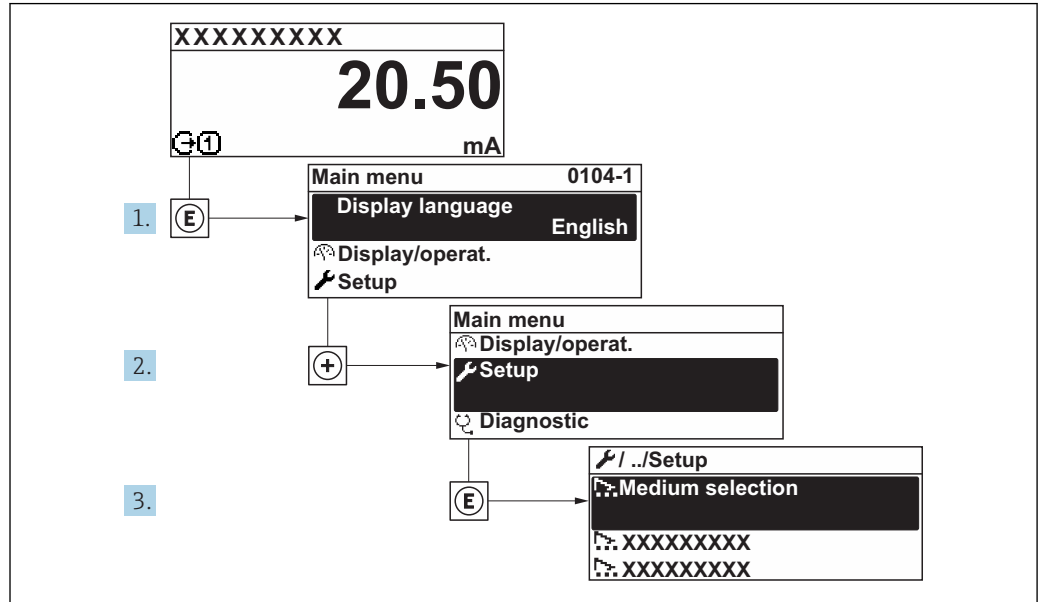

34 Taking the example of the local display

A003222-EN

i The number of submenus and parameters can vary depending on the device version. Certain submenus and parameters in these submenus are not described in the Operation Instructions. Instead a description is provided in the Special Documentation for the device (→ "Supplementary documentation" section).

Setup

Device tag	
▶ Measurement mode	→ 81
▶ Reference conditions	→ 85
▶ Sensor adjustment	→ 87
▶ System units	→ 88
▶ Communication	
▶ I/O configuration	→ 90
▶ Current input 1 to n	→ 91
▶ Status input 1 to n	→ 87
▶ Current output 1 to n	→ 92

▶ Pulse/frequency/switch output 1 to n	→ 95
▶ Relay output 1 to n	→ 101
▶ Display	→ 102
▶ Low flow cut off	→ 106
▶ Advanced setup	→ 107

9.4.1 Defining the tag name

To enable fast identification of the measuring point within the system, you can enter a unique designation using the **Device tag** parameter and thus change the factory setting.

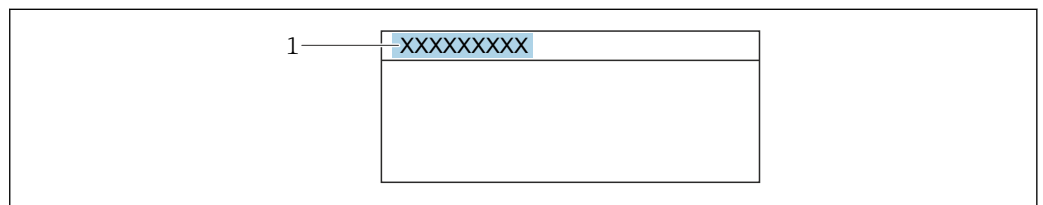

A0029422

35 Header of the operational display with tag name

1 Tag name

Enter the tag name in the "FieldCare" operating tool → 72

Navigation

"Setup" menu → Device tag

Parameter overview with brief description

Parameter	Description	User entry	Factory setting
Device tag	Enter the name for the measuring point.	Max. 32 characters, such as letters, numbers or special characters (e.g. @, %, /).	Prowirl

9.4.2 Configuring the measurement mode

Properties of the medium can be configured in the **Measurement mode** submenu.

Navigation

"Setup" menu → Measurement mode

▶ Measurement mode	
Measurement application	→ 83
Select gas type	→ 83

Gas	→ 83
Gas composition	→ 83
Mol% Air	→ 83
Mol% Ar	→ 84
Mol% C ₂ H ₄	→ 84
Mol% C ₂ H ₆	→ 84
Mol% C ₃ H ₈	→ 84
Mol% CH ₄	→ 84
Mol% Cl ₂	→ 84
Mol% CO	→ 84
Mol% CO ₂	→ 84
Mol% H ₂	→ 84
Mol% H ₂ O	→ 84
Mol% H ₂ S	→ 84
Mol% HCl	→ 84
Mol% He	→ 84
Mol% Kr	→ 84
Mol% N ₂	→ 84
Mol% n-C ₄ H ₁₀	→ 84
Mol% Ne	→ 85
Mol% NH ₃	→ 85
Mol% O ₂	→ 85
Mol% O ₃	→ 85
Mol% Xe	→ 85
Special gas name	→ 85

Parameter overview with brief description

Parameter	Prerequisite	Description	Selection / User entry / User interface	Factory setting
Measurement application	–	Select measurement application.	<ul style="list-style-type: none"> ■ Air or compressed air ■ Gas or gas mixture ■ Energy 	Air or compressed air
Select gas type	–	Select measured gas type.	<ul style="list-style-type: none"> ■ Single gas ■ Gas mixture ■ Special gas * 	Single gas
Gas	The Single gas option is selected in the Select gas type parameter parameter.	Select measured gas.	<ul style="list-style-type: none"> ■ Air ■ Ammonia NH3 ■ Argon Ar ■ Butane C4H10 ■ Carbon dioxide CO2 ■ Carbon monoxide CO ■ Chlorine Cl2 ■ Ethane C2H6 ■ Ethylene C2H4 ■ Helium He ■ Hydrogen H2 ■ Hydrogen chloride HCl ■ Hydrogen sulfide H2S ■ Krypton Kr ■ Methane CH4 ■ Neon Ne ■ Nitrogen N2 ■ Oxygen O2 ■ Ozone O3 ■ Propane C3H8 ■ Xenon Xe 	Air
Gas composition	The Gas mixture option is selected in the Select gas type parameter parameter.	Select measured gas mixture.	<ul style="list-style-type: none"> ■ Air ■ Hydrogen H2 ■ Helium He ■ Neon Ne ■ Argon Ar ■ Krypton Kr ■ Xenon Xe ■ Nitrogen N2 ■ Oxygen O2 ■ Chlorine Cl2 ■ Ammonia NH3 ■ Carbon monoxide CO ■ Carbon dioxide CO2 ■ Hydrogen sulfide H2S ■ Hydrogen chloride HCl ■ Methane CH4 ■ Propane C3H8 ■ Ethane C2H6 ■ Butane C4H10 ■ Ethylene C2H4 ■ Water ■ Ozone O3 	Air
Mol% Air	–	Enter amount of substance for the gas mixture. Air	0 to 100 %	100 %

Parameter	Prerequisite	Description	Selection / User entry / User interface	Factory setting
Mol% Ar	-	Enter amount of substance for the gas mixture. Ar = Argon	0 to 100 %	0 %
Mol% C2H4	-	Enter amount of substance for the gas mixture. C ₂ H ₄ = ethylene	0 to 100 %	0 %
Mol% C2H6	-	Enter amount of substance for the gas mixture. C ₂ H ₆ = ethane	0 to 100 %	0 %
Mol% C3H8	-	Enter amount of substance for the gas mixture. C ₃ H ₈ = propane	0 to 100 %	0 %
Mol% CH4	-	Enter amount of substance for the gas mixture. CH ₄ = methane	0 to 100 %	0 %
Mol% Cl2	-	Enter amount of substance for the gas mixture. Cl ₂ = chlorine	0 to 100 %	0 %
Mol% CO	-	Enter amount of substance for the gas mixture. CO = carbon monoxide	0 to 100 %	0 %
Mol% CO2	-	Enter amount of substance for the gas mixture. CO ₂ = carbon dioxide	0 to 100 %	0 %
Mol% H2	-	Enter amount of substance for the gas mixture. H ₂ = hydrogen	0 to 100 %	0 %
Mol% H2O	-	Enter amount of substance for the gas mixture. H ₂ O = water	0 to 20 %	0 %
Mol% H2S	-	Enter amount of substance for the gas mixture. H ₂ S = hydrogen sulfide	0 to 100 %	0 %
Mol% HCl	-	Enter amount of substance for the gas mixture. HCl = hydrogen chloride	0 to 100 %	0 %
Mol% He	-	Enter amount of substance for the gas mixture. He = helium	0 to 100 %	0 %
Mol% Kr	-	Enter amount of substance for the gas mixture. Kr = krypton	0 to 100 %	0 %
Mol% N2	-	Enter amount of substance for the gas mixture. N ₂ = nitrogen	0 to 100 %	0 %
Mol% n-C4H10	-	Enter amount of substance for the gas mixture. n-C ₄ H ₁₀ = n-butane	0 to 100 %	0 %

Parameter	Prerequisite	Description	Selection / User entry / User interface	Factory setting
Mol% Ne	–	Enter amount of substance for the gas mixture. Ne = neon	0 to 100 %	0 %
Mol% NH ₃	–	Enter amount of substance for the gas mixture. NH ₃ = ammonia	0 to 100 %	0 %
Mol% O ₂	–	Enter amount of substance for the gas mixture. O ₂ = oxygen	0 to 100 %	0 %
Mol% O ₃	Mixture only possible with O ₂ . <ul style="list-style-type: none"> ■ O₃: 65 to 100 % ■ O₂: 0 to 35 % 	Enter amount of substance for the gas mixture.	65 to 100 %	0 %
Mol% Xe	–	Enter amount of substance for the gas mixture. Xe = xenon	0 to 100 %	0 %
Special gas name	Special gas option application package is available.	Shows the description of the gas ordered by the customer, e.g. gas name or gas composition.	-	-

* Visibility depends on order options or device settings

9.4.3 Configuring reference conditions

Reference properties can be configured in the **Reference conditions** submenu.

Navigation

"Setup" menu → Reference conditions

▶ Reference conditions	
Reference conditions	→ ⓘ 86
Reference pressure	→ ⓘ 86
Reference temperature	→ ⓘ 86
FAD conditions	→ ⓘ 86
FAD pressure	→ ⓘ 86
FAD temperature	→ ⓘ 86
Reference combustion temperature	
Reference combustion temperature	→ ⓘ 86

Parameter overview with brief description

Parameter	Prerequisite	Description	Selection / User entry	Factory setting
Reference conditions	–	Select reference conditions for calculation of the corrected volume flow.	<ul style="list-style-type: none"> ■ 1013.25 mbara, 0 °C ■ 1013.25 mbara, 15 °C ■ 1013.25 mbara, 20 °C ■ 1013.25 mbara, 25 °C ■ 1000 mbara, 0 °C ■ 1000 mbara, 15 °C ■ 1000 mbara, 20 °C ■ 1000 mbara, 25 °C ■ 14.696 psia, 59 °F ■ 14.696 psia, 60 °F ■ User-defined 	1000 mbara, 0 °C
Reference pressure	The Others option is selected in the Reference conditions parameter.	Select reference conditions for the corrected volume flow.	0 to 250 bar a	1.01325 bar a
Reference temperature	The Others option is selected in the Reference conditions parameter.	Select reference conditions for the corrected volume flow.	–200 to 450 °C	20 °C
FAD conditions	The Air or compressed air option is selected in the Measurement application parameter.	Select reference conditions for the calculation of the FAD density (FAD = free air delivery).	<ul style="list-style-type: none"> ■ 1000 mbara, 20 °C ■ 14.504 psia, 68 °F ■ User-defined 	1000 mbara, 20 °C
FAD pressure	<ul style="list-style-type: none"> ■ The Air or compressed air option is selected in the Measurement application parameter. ■ The User-defined option is selected in the FAD conditions parameter. 	Enter reference pressure for the calculation of the FAD density (FAD = free air delivery).	0 to 250 bar a	1 bar a
FAD temperature	<ul style="list-style-type: none"> ■ The Air or compressed air option is selected in the Measurement application parameter. ■ The User-defined option is selected in the FAD conditions parameter. 	Enter reference temperature for the calculation of the FAD density (FAD = free air delivery).	–200 to 450 °C	20 °C
Reference combustion temperature	The Energy option is selected in the Measurement application parameter.	Enter reference combustion temperature to calculate the natural gas energy value.	–200 to 450 °C	20 °C

9.4.4 Sensor adjustment

Parameters pertaining to the pipe shape of the insertion version can be configured in the **Sensor adjustment** submenu.

 The number of submenus and parameters can vary depending on the device version. Certain submenus and parameters in these submenus are not described in the Operation Instructions. Instead a description is provided in the Special Documentation for the device (→ "Supplementary documentation" section).

▶ Sensor adjustment

Installation direction

→  87

Installation factor

→  87

Parameter overview with brief description

Parameter	Description	Selection / User entry	Factory setting
Installation direction	Set sign of flow direction to match the direction of the arrow on the sensor.	<ul style="list-style-type: none"> ■ Forward flow ■ Reverse flow 	Forward flow
Installation factor	Enter factor to compensate the mounting-related measurement error.	0.01 to 100.0	1

9.4.5 Configuring the status input

The **Status input** submenu guides the user systematically through all the parameters that have to be set for configuring the status input.

Navigation

"Setup" menu → Status input

▶ Status input 1 to n

Assign status input

→  88

Terminal number

→  88

Active level

→  88

Terminal number

→  88

Response time status input

→  88

Terminal number

→  88

Parameter overview with brief description

Parameter	Description	Selection / User interface / User entry	Factory setting
Assign status input	Select function for the status input.	<ul style="list-style-type: none"> ■ Off ■ Reset totalizer 1 ■ Reset totalizer 2 ■ Reset totalizer 3 ■ Reset all totalizers ■ Flow override ■ Gas group * ■ Zero point adjustment 	Off
Terminal number	Shows the terminal numbers used by the status input module.	<ul style="list-style-type: none"> ■ Not used ■ 24-25 (I/O 2) ■ 22-23 (I/O 3) ■ 20-21 (I/O 4) * 	–
Active level	Define input signal level at which the assigned function is triggered.	<ul style="list-style-type: none"> ■ High ■ Low 	High
Response time status input	Define the minimum amount of time the input signal level must be present before the selected function is triggered.	5 to 200 ms	50 ms

* Visibility depends on order options or device settings









9.4.6 Setting the system units









In the **System units** submenu the units of all the measured values can be set.

 The number of submenus and parameters can vary depending on the device version. Certain submenus and parameters in these submenus are not described in the Operation Instructions. Instead a description is provided in the Special Documentation for the device (→ "Supplementary documentation" section).

Navigation

"Setup" menu → System units

▶ System units	
Mass flow unit	→  89
Mass unit	→  89
Corrected volume flow unit	→  89
Corrected volume unit	→  89
Volume flow unit	→  89
Volume unit	→  89
FAD volume flow unit	→  89
FAD volume unit	→  89
Energy flow unit	→  89

Energy unit	→  89
Calorific value unit	→  89
Density unit	→  90
Temperature unit	→  90
Pressure unit	→  90
Velocity unit	→  90
Length unit	→  90
Date/time format	→  90

Parameter overview with brief description

Parameter	Description	Selection	Factory setting
Mass flow unit	Select mass flow unit.	Unit choose list	Country-specific: <ul style="list-style-type: none"> ■ kg/h ■ lb/h
Mass unit	Select mass unit.	Unit choose list	Country-specific: <ul style="list-style-type: none"> ■ kg ■ lb
Corrected volume flow unit	Select corrected volume flow unit.	Unit choose list	Country-specific: <ul style="list-style-type: none"> ■ Nm³/h ■ Sft³/h
Corrected volume unit	Select corrected volume unit.	Unit choose list	Country-specific: <ul style="list-style-type: none"> ■ Nm³ ■ Sft³
Volume flow unit	Select volume flow unit.	Unit choose list	Country-specific: <ul style="list-style-type: none"> ■ l/h ■ ft³/h
Volume unit	Select volume unit.	Unit choose list	Country-specific: <ul style="list-style-type: none"> ■ ft³ ■ m³
FAD volume flow unit	Select FAD volumen flow unit (FAD = free air delivery).	Unit choose list	Country-specific: <ul style="list-style-type: none"> ■ m³ FAD/h ■ cf FAD/min
FAD volume unit	Select FAD volumen unit (FAD = free air delivery).	Unit choose list	Country-specific: <ul style="list-style-type: none"> ■ m³ FAD ■ cf FAD
Energy flow unit	Select energy flow unit.	Unit choose list	Country-specific: <ul style="list-style-type: none"> ■ kW ■ Btu/h
Energy unit	Select energy unit.	Unit choose list	Country-specific: <ul style="list-style-type: none"> ■ kWh ■ Btu
Calorific value unit	Select calorific value unit.	Unit choose list	Country-specific: <ul style="list-style-type: none"> ■ kWh/Nm³ ■ Btu/Sft³

Parameter	Description	Selection	Factory setting
Density unit	Select density unit.	Unit choose list	Country-specific: <ul style="list-style-type: none"> ■ kg/m³ ■ lb/ft³
Temperature unit	Select temperature unit.	Unit choose list	Country-specific: <ul style="list-style-type: none"> ■ °C ■ °F
Pressure unit	Select process pressure unit.	Unit choose list	Country-specific: <ul style="list-style-type: none"> ■ bar a ■ psi a
Velocity unit	Select velocity unit.	Unit choose list	Country-specific: <ul style="list-style-type: none"> ■ m/s ■ ft/s
Length unit	Select length unit for nominal diameter.	Unit choose list	Country-specific: <ul style="list-style-type: none"> ■ mm ■ in
Date/time format	Select date and time format.	<ul style="list-style-type: none"> ■ dd.mm.yy hh:mm ■ dd.mm.yy hh:mm am/pm ■ mm/dd/yy hh:mm ■ mm/dd/yy hh:mm am/pm 	dd.mm.yy hh:mm

9.4.7 Displaying the I/O configuration

The **I/O configuration** submenu guides the user systematically through all the parameters in which the configuration of the I/O modules is displayed.

Navigation

"Setup" menu → I/O configuration

▶ I/O configuration	
I/O module 1 to n terminal numbers	→ ⓘ 90
I/O module 1 to n information	→ ⓘ 90
I/O module 1 to n type	→ ⓘ 91
Apply I/O configuration	→ ⓘ 91
I/O alteration code	→ ⓘ 91

Parameter overview with brief description

Parameter	Description	User interface / Selection / User entry	Factory setting
I/O module 1 to n terminal numbers	Shows the terminal numbers used by the I/O module.	<ul style="list-style-type: none"> ■ Not used ■ 26-27 (I/O 1) ■ 24-25 (I/O 2) ■ 22-23 (I/O 3) ■ 20-21 (I/O 4) * 	–
I/O module 1 to n information	Shows information of the plugged I/O module.	<ul style="list-style-type: none"> ■ Not plugged ■ Invalid ■ Not configurable ■ Configurable ■ MODBUS 	–

Parameter	Description	User interface / Selection / User entry	Factory setting
I/O module 1 to n type	Shows the I/O module type.	<ul style="list-style-type: none"> ■ Off ■ Current output * ■ Current input * ■ Status input * ■ Pulse/frequency/switch output * ■ Relay output * 	Off
Apply I/O configuration	Apply parameterization of the freely configurable I/O module.	<ul style="list-style-type: none"> ■ No ■ Yes 	No
I/O alteration code	Enter the code in order to change the I/O configuration.	Positive integer	0

* Visibility depends on order options or device settings

9.4.8 Configuring the current input

The "Current input" wizard guides the user systematically through all the parameters that have to be set for configuring the current input.

Navigation

"Setup" menu → Current input

▶ Current input 1 to n

Current span	→ ⓘ 92
Terminal number	→ ⓘ 92
Signal mode	→ ⓘ 92
Terminal number	→ ⓘ 92
0/4 mA value	→ ⓘ 92
20 mA value	→ ⓘ 92
Failure mode	→ ⓘ 92
Terminal number	→ ⓘ 92
Failure value	→ ⓘ 92
Terminal number	→ ⓘ 92

Parameter overview with brief description

Parameter	Prerequisite	Description	Selection / User interface / User entry	Factory setting
Current span	-	Select current range for process value output and upper/lower level for alarm signal.	<ul style="list-style-type: none"> ▪ 4...20 mA (4...20.5 mA) ▪ 4...20 mA NAMUR (3.8...20.5 mA) ▪ 4...20 mA US (3.9...20.8 mA) ▪ 0...20 mA (0...20.5 mA) 	Country-specific: <ul style="list-style-type: none"> ▪ 4...20 mA NAMUR (3.8...20.5 mA) ▪ 4...20 mA US (3.9...20.8 mA)
Terminal number	-	Shows the terminal numbers used by the current input module.	<ul style="list-style-type: none"> ▪ Not used ▪ 24-25 (I/O 2) ▪ 22-23 (I/O 3) ▪ 20-21 (I/O 4) * 	-
Signal mode	The measuring device is not approved for use in the hazardous area with type of protection Ex-i.	Select the signal mode for the current input.	<ul style="list-style-type: none"> ▪ Passive ▪ Active * 	Active
0/4 mA value	-	Enter 4 mA value.	Signed floating-point number	0
20 mA value	-	Enter 20 mA value.	Signed floating-point number	Depends on country and nominal diameter
Failure mode	-	Define input behavior in alarm condition.	<ul style="list-style-type: none"> ▪ Alarm ▪ Last valid value ▪ Defined value 	Alarm
Failure value	In the Failure mode parameter, the Defined value option is selected.	Enter value to be used by the device if input value from external device is missing.	Signed floating-point number	0

* Visibility depends on order options or device settings

9.4.9 Configuring the current output

The **Current output** wizard guides you systematically through all the parameters that have to be set for configuring the current output.

Navigation

"Setup" menu → Current output







▶ **Current output 1 to n**

Assign current output 1 to n	→ ⓘ 93
Terminal number	→ ⓘ 93
Current span	→ ⓘ 93
Terminal number	→ ⓘ 93
Signal mode	→ ⓘ 93
Terminal number	→ ⓘ 93

0/4 mA value	→ 94
20 mA value	→ 94
Fixed current	→ 94
Terminal number	→ 93
Damping output 1 to n	→ 94
Failure mode	→ 94
Terminal number	→ 93
Failure current	→ 94
Terminal number	→ 93

Parameter overview with brief description

Parameter	Prerequisite	Description	Selection / User interface / User entry	Factory setting
Assign current output 1 to n	–	Select process variable for current output.	<ul style="list-style-type: none"> ■ Off * ■ Temperature ■ Mass flow ■ Corrected volume flow ■ FAD volume flow * ■ Volume flow ■ Energy flow * ■ Heat flow * ■ Density ■ Flow velocity ■ Pressure ■ 2nd temperature delta heat * ■ Electronic temperature 	Mass flow
Terminal number	–	Shows the terminal numbers used by the current output module.	<ul style="list-style-type: none"> ■ Not used ■ 24-25 (I/O 2) ■ 22-23 (I/O 3) ■ 20-21 (I/O 4) * 	–
Current span	–	Select current range for process value output and upper/lower level for alarm signal.	<ul style="list-style-type: none"> ■ 4...20 mA NAMUR (3.8...20.5 mA) ■ 4...20 mA US (3.9...20.8 mA) ■ 4...20 mA (4...20.5 mA) ■ 0...20 mA (0...20.5 mA) ■ Fixed current 	Country-specific: <ul style="list-style-type: none"> ■ 4...20 mA NAMUR (3.8...20.5 mA) ■ 4...20 mA US (3.9...20.8 mA)
Signal mode	–	Select the signal mode for the current output.	<ul style="list-style-type: none"> ■ Active * ■ Passive * 	Active

Parameter	Prerequisite	Description	Selection / User interface / User entry	Factory setting
0/4 mA value	In the Current span parameter (→  93), one of the following options is selected: <ul style="list-style-type: none"> ▪ 4...20 mA NAMUR (3.8...20.5 mA) ▪ 4...20 mA US (3.9...20.8 mA) ▪ 4...20 mA (4... 20.5 mA) ▪ 0...20 mA (0... 20.5 mA) 	Enter 4 mA value.	Signed floating-point number	0 kg/h
20 mA value	In the Current span parameter (→  93), one of the following options is selected: <ul style="list-style-type: none"> ▪ 4...20 mA NAMUR (3.8...20.5 mA) ▪ 4...20 mA US (3.9...20.8 mA) ▪ 4...20 mA (4... 20.5 mA) ▪ 0...20 mA (0... 20.5 mA) 	Enter 20 mA value.	Signed floating-point number	Depends on country and nominal diameter
Fixed current	The Fixed current option is selected in the Current span parameter (→  93).	Defines the fixed output current.	0 to 22.5 mA	22.5 mA
Damping output 1 to n	A process variable is selected in the Assign current output parameter (→  93) and one of the following options is selected in the Current span parameter (→  93): <ul style="list-style-type: none"> ▪ 4...20 mA NAMUR (3.8...20.5 mA) ▪ 4...20 mA US (3.9...20.8 mA) ▪ 4...20 mA (4... 20.5 mA) ▪ 0...20 mA (0... 20.5 mA) 	Set reaction time for output signal to fluctuations in the measured value.	0.0 to 999.9 s	1.0 s
Failure mode	A process variable is selected in the Assign current output parameter (→  93) and one of the following options is selected in the Current span parameter (→  93): <ul style="list-style-type: none"> ▪ 4...20 mA NAMUR (3.8...20.5 mA) ▪ 4...20 mA US (3.9...20.8 mA) ▪ 4...20 mA (4... 20.5 mA) ▪ 0...20 mA (0... 20.5 mA) 	Define output behavior in alarm condition.	<ul style="list-style-type: none"> ▪ Min. ▪ Max. ▪ Last valid value ▪ Actual value ▪ Defined value 	Max.
Failure current	The Defined value option is selected in the Failure mode parameter.	Enter current output value in alarm condition.	0 to 22.5 mA	22.5 mA

* Visibility depends on order options or device settings

9.4.10 Configuring the pulse/frequency/switch output

The **Pulse/frequency/switch output** wizard guides you systematically through all the parameters that can be set for configuring the selected output type.

Navigation

"Setup" menu → Advanced setup → Pulse/frequency/switch output

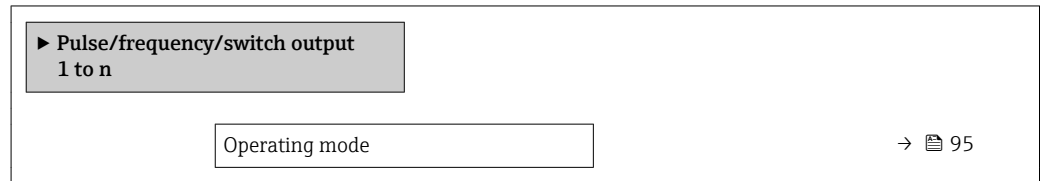

Parameter overview with brief description

Parameter	Description	Selection	Factory setting
Operating mode	Define the output as a pulse, frequency or switch output.	<ul style="list-style-type: none"> ■ Pulse ■ Frequency ■ Switch 	Pulse

Configuring the pulse output

Navigation

"Setup" menu → Pulse/frequency/switch output

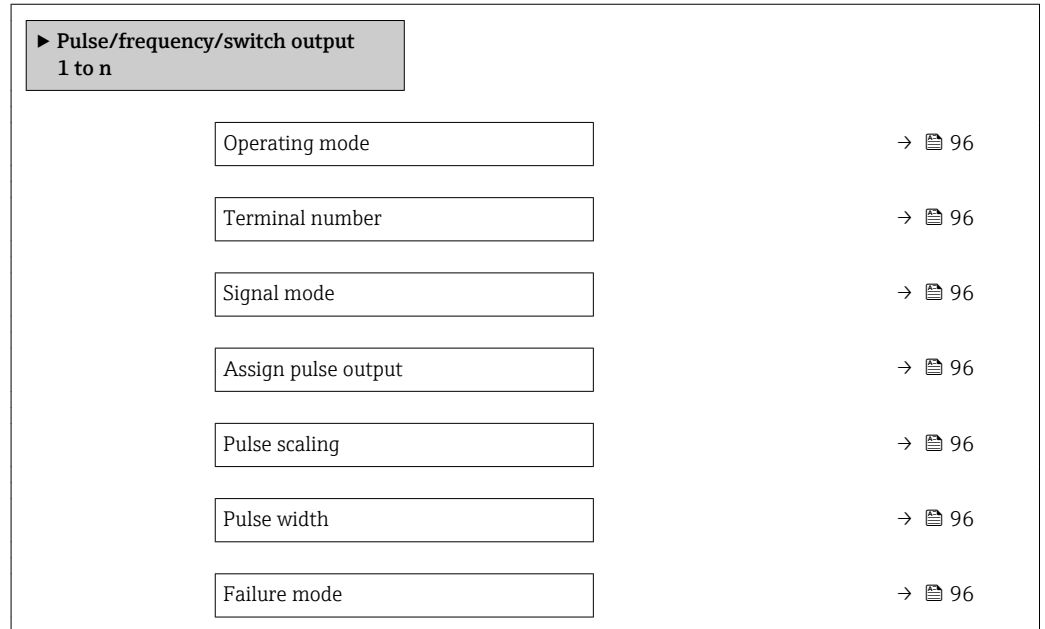

Parameter overview with brief description

Parameter	Prerequisite	Description	Selection / User interface / User entry	Factory setting
Operating mode	–	Define the output as a pulse, frequency or switch output.	<ul style="list-style-type: none"> ▪ Pulse ▪ Frequency ▪ Switch 	Pulse
Terminal number	–	Shows the terminal numbers used by the PFS output module.	<ul style="list-style-type: none"> ▪ Not used ▪ 24-25 (I/O 2) ▪ 22-23 (I/O 3) ▪ 20-21 (I/O 4) * 	–
Signal mode	–	Select the signal mode for the PFS output.	<ul style="list-style-type: none"> ▪ Passive ▪ Active * ▪ Passive NAMUR 	Passive
Assign pulse output 1 to n	The Pulse option is selected in the Operating mode parameter parameter.	Select process variable for pulse output.	<ul style="list-style-type: none"> ▪ Off ▪ Mass flow ▪ Corrected volume flow ▪ FAD volume flow * ▪ Volume flow * ▪ Energy flow * ▪ Heat flow * 	Off
Pulse scaling	The Pulse option is selected in the Operating mode parameter (→ 95) and a process variable is selected in the Assign pulse output parameter (→ 96).	Enter quantity for measured value at which a pulse is output.	Positive floating point number	Depends on country and nominal diameter
Pulse width	The Pulse option is selected in the Operating mode parameter (→ 95) and a process variable is selected in the Assign pulse output parameter (→ 96).	Define time width of the output pulse.	0.05 to 2 000 ms	100 ms
Failure mode	The Pulse option is selected in the Operating mode parameter (→ 95) and a process variable is selected in the Assign pulse output parameter (→ 96).	Define output behavior in alarm condition.	<ul style="list-style-type: none"> ▪ Actual value ▪ No pulses 	No pulses

* Visibility depends on order options or device settings









Configuring the frequency output

Navigation



"Setup" menu → Pulse/frequency/switch output

▶ Pulse/frequency/switch output
1 to n

Operating mode	→ 97
Terminal number	→ 97
Signal mode	→ 97

Assign frequency output	→  97
Minimum frequency value	→  97
Maximum frequency value	→  98
Measuring value at minimum frequency	→  98
Measuring value at maximum frequency	→  98
Failure mode	→  98
Failure frequency	→  98
Invert output signal	→  98

Parameter overview with brief description

Parameter	Prerequisite	Description	Selection / User interface / User entry	Factory setting
Operating mode	–	Define the output as a pulse, frequency or switch output.	<ul style="list-style-type: none"> ■ Pulse ■ Frequency ■ Switch 	Pulse
Terminal number	–	Shows the terminal numbers used by the PFS output module.	<ul style="list-style-type: none"> ■ Not used ■ 24-25 (I/O 2) ■ 22-23 (I/O 3) ■ 20-21 (I/O 4)* 	–
Signal mode	–	Select the signal mode for the PFS output.	<ul style="list-style-type: none"> ■ Passive ■ Active* ■ Passive NAMUR 	Passive
Assign frequency output	The Frequency option is selected in the Operating mode parameter (→  95).	Select process variable for frequency output.	<ul style="list-style-type: none"> ■ Off ■ Temperature ■ Mass flow ■ Corrected volume flow ■ FAD volume flow* ■ Volume flow* ■ Energy flow* ■ Heat flow* ■ Density ■ Flow velocity ■ Pressure ■ 2nd temperature delta heat* ■ Electronic temperature 	Off
Minimum frequency value	The Frequency option is selected in the Operating mode parameter (→  95) and a process variable is selected in the Assign frequency output parameter (→  97).	Enter minimum frequency.	0.0 to 10 000.0 Hz	0.0 Hz

Parameter	Prerequisite	Description	Selection / User interface / User entry	Factory setting
Maximum frequency value	The Frequency option is selected in the Operating mode parameter (→ 95) and a process variable is selected in the Assign frequency output parameter (→ 97).	Enter maximum frequency.	0.0 to 10 000.0 Hz	10 000.0 Hz
Measuring value at minimum frequency	The Frequency option is selected in the Operating mode parameter (→ 95) and a process variable is selected in the Assign frequency output parameter (→ 97).	Enter measured value for minimum frequency.	Signed floating-point number	Depends on country and nominal diameter
Measuring value at maximum frequency	The Frequency option is selected in the Operating mode parameter (→ 95) and a process variable is selected in the Assign frequency output parameter (→ 97).	Enter measured value for maximum frequency.	Signed floating-point number	Depends on country and nominal diameter
Failure mode	The Frequency option is selected in the Operating mode parameter (→ 95) and a process variable is selected in the Assign frequency output parameter (→ 97).	Define output behavior in alarm condition.	<ul style="list-style-type: none"> ▪ Actual value ▪ Defined value ▪ 0 Hz 	0 Hz
Failure frequency	The Frequency option is selected in the Operating mode parameter (→ 95) and a process variable is selected in the Assign frequency output parameter (→ 97).	Enter frequency output value in alarm condition.	0.0 to 12 500.0 Hz	0.0 Hz
Invert output signal	–	Invert the output signal.	<ul style="list-style-type: none"> ▪ No ▪ Yes 	No

* Visibility depends on order options or device settings

Configuring the switch output

Navigation

"Setup" menu → Pulse/frequency/switch output

► Pulse/frequency/switch output 1 to n		
Operating mode		→ 99
Terminal number		→ 99
Signal mode		→ 99
Switch output function		→ 100
Assign diagnostic behavior		→ 100
Assign limit		→ 100
Assign status		→ 100
Switch-on value		→ 100
Switch-off value		→ 100
Switch-on delay		→ 100
Switch-off delay		→ 101
Failure mode		→ 101

Parameter overview with brief description

Parameter	Prerequisite	Description	Selection / User interface / User entry	Factory setting
Operating mode	–	Define the output as a pulse, frequency or switch output.	<ul style="list-style-type: none"> ■ Pulse ■ Frequency ■ Switch 	Pulse
Terminal number	–	Shows the terminal numbers used by the PFS output module.	<ul style="list-style-type: none"> ■ Not used ■ 24-25 (I/O 2) ■ 22-23 (I/O 3) ■ 20-21 (I/O 4) * 	–
Signal mode	–	Select the signal mode for the PFS output.	<ul style="list-style-type: none"> ■ Passive ■ Active * ■ Passive NAMUR 	Passive

Parameter	Prerequisite	Description	Selection / User interface / User entry	Factory setting
Switch output function	The Switch option is selected in the Operating mode parameter.	Select function for switch output.	<ul style="list-style-type: none"> ▪ Off ▪ On ▪ Diagnostic behavior ▪ Limit ▪ Flow direction check * ▪ Status 	Off
Assign diagnostic behavior	<ul style="list-style-type: none"> ▪ In the Operating mode parameter, the Switch option is selected. ▪ In the Switch output function parameter, the Diagnostic behavior option is selected. 	Select diagnostic behavior for switch output.	<ul style="list-style-type: none"> ▪ Alarm ▪ Alarm or warning ▪ Warning 	Alarm
Assign limit	<ul style="list-style-type: none"> ▪ The Switch option is selected in the Operating mode parameter. ▪ The Limit option is selected in the Switch output function parameter. 	Select process variable for limit function.	<ul style="list-style-type: none"> ▪ Temperature ▪ Mass flow ▪ Corrected volume flow ▪ FAD volume flow * ▪ Volume flow ▪ Energy flow * ▪ Heat flow * ▪ Density ▪ Flow velocity ▪ 2nd temperature delta heat * ▪ Electronic temperature ▪ Totalizer 1 ▪ Totalizer 2 ▪ Totalizer 3 	Mass flow
Assign status	<ul style="list-style-type: none"> ▪ The Switch option is selected in the Operating mode parameter. ▪ The Status option is selected in the Switch output function parameter. 	Select device status for switch output.	<ul style="list-style-type: none"> ▪ Off ▪ Low flow cut off 	Low flow cut off
Switch-on value	<ul style="list-style-type: none"> ▪ The Switch option is selected in the Operating mode parameter. ▪ The Limit option is selected in the Switch output function parameter. 	Enter measured value for the switch-on point.	Signed floating-point number	Depends on country and nominal diameter
Switch-off value	<ul style="list-style-type: none"> ▪ The Switch option is selected in the Operating mode parameter. ▪ The Limit option is selected in the Switch output function parameter. 	Enter measured value for the switch-off point.	Signed floating-point number	0 kg/h
Switch-on delay	<ul style="list-style-type: none"> ▪ The Switch option is selected in the Operating mode parameter. ▪ The Limit option is selected in the Switch output function parameter. 	Define delay for the switch-on of status output.	0.0 to 100.0 s	0.0 s

Parameter	Prerequisite	Description	Selection / User interface / User entry	Factory setting
Switch-off delay	<ul style="list-style-type: none"> ▪ The Switch option is selected in the Operating mode parameter. ▪ The Limit option is selected in the Switch output function parameter. 	Define delay for the switch-off of status output.	0.0 to 100.0 s	0.0 s
Failure mode	–	Define output behavior in alarm condition.	<ul style="list-style-type: none"> ▪ Actual status ▪ Open ▪ Closed 	Open

* Visibility depends on order options or device settings

9.4.11 Configuring the relay output

The **Relay output** wizard guides the user systematically through all the parameters that have to be set for configuring the relay output.

Navigation

"Setup" menu → Relay output 1 to n

▶ Relay output 1 to n

Terminal number	→ 102
Relay output function	→ 102
Assign limit	→ 102
Assign diagnostic behavior	→ 102
Assign status	→ 102
Switch-off value	→ 102
Switch-off delay	→ 102
Switch-on value	→ 102
Switch-on delay	→ 102
Failure mode	→ 102

Parameter overview with brief description

Parameter	Prerequisite	Description	User interface / Selection / User entry	Factory setting
Terminal number	–	Shows the terminal numbers used by the relay output module.	<ul style="list-style-type: none"> ▪ Not used ▪ 24-25 (I/O 2) ▪ 22-23 (I/O 3) ▪ 20-21 (I/O 4) 	–
Relay output function	–	Select the function for the relay output.	<ul style="list-style-type: none"> ▪ Closed ▪ Open ▪ Diagnostic behavior ▪ Limit ▪ Flow direction check ▪ Digital Output 	Closed
Assign limit	The Limit option is selected in the Relay output function parameter.	Select process variable for limit function.	<ul style="list-style-type: none"> ▪ Temperature ▪ Mass flow ▪ Corrected volume flow ▪ FAD volume flow * ▪ Volume flow * ▪ Energy flow * ▪ Heat flow * ▪ Density ▪ Flow velocity ▪ 2nd temperature delta heat * ▪ Electronic temperature ▪ Totalizer 1 ▪ Totalizer 2 ▪ Totalizer 3 	Mass flow
Assign diagnostic behavior	In the Relay output function parameter, the Diagnostic behavior option is selected.	Select diagnostic behavior for switch output.	<ul style="list-style-type: none"> ▪ Alarm ▪ Alarm or warning ▪ Warning 	Alarm
Assign status	In the Relay output function parameter, the Digital Output option is selected.	Select device status for switch output.	<ul style="list-style-type: none"> ▪ Off ▪ Low flow cut off 	Off
Switch-off value	In the Relay output function parameter, the Limit option is selected.	Enter measured value for the switch-off point.	Signed floating-point number	0 kg/h
Switch-off delay	In the Relay output function parameter, the Limit option is selected.	Define delay for the switch-off of status output.	0.0 to 100.0 s	0.0 s
Switch-on value	The Limit option is selected in the Relay output function parameter parameter.	Enter measured value for the switch-on point.	Signed floating-point number	Depends on country and nominal diameter
Switch-on delay	In the Relay output function parameter, the Limit option is selected.	Define delay for the switch-on of status output.	0.0 to 100.0 s	0.0 s
Failure mode	–	Define output behavior in alarm condition.	<ul style="list-style-type: none"> ▪ Actual status ▪ Open ▪ Closed 	Open

* Visibility depends on order options or device settings

9.4.12 Configuring the local display

The **Display** wizard guides you systematically through all the parameters that can be configured for configuring the local display.

Navigation
 "Setup" menu → Display

▶ Display		
Format display	→	📄 103
Value 1 display	→	📄 103
0% bargraph value 1	→	📄 104
100% bargraph value 1	→	📄 104
Value 2 display	→	📄 104
Value 3 display	→	📄 104
0% bargraph value 3	→	📄 104
100% bargraph value 3	→	📄 105
Value 4 display	→	📄 105

Parameter overview with brief description

Parameter	Prerequisite	Description	Selection / User entry	Factory setting
Format display	A local display is provided.	Select how measured values are shown on the display.	<ul style="list-style-type: none"> ▪ 1 value, max. size ▪ 1 bargraph + 1 value ▪ 2 values ▪ 1 value large + 2 values ▪ 4 values 	1 value, max. size
Value 1 display	A local display is provided.	Select the measured value that is shown on the local display.	<ul style="list-style-type: none"> ▪ Temperature ▪ Mass flow ▪ Corrected volume flow ▪ FAD volume flow * ▪ Volume flow * ▪ Energy flow * ▪ Heat flow * ▪ Density ▪ Flow velocity ▪ Pressure ▪ 2nd temperature delta heat * ▪ Electronic temperature ▪ Totalizer 1 ▪ Totalizer 2 ▪ Totalizer 3 ▪ Current output 1 * ▪ Current output 2 * ▪ Current output 3 * ▪ Current output 4 * 	Mass flow

Parameter	Prerequisite	Description	Selection / User entry	Factory setting
0% bargraph value 1	A local display is provided.	Enter 0% value for bar graph display.	Signed floating-point number	0 kg/h
100% bargraph value 1	A local display is provided.	Enter 100% value for bar graph display.	Signed floating-point number	Depends on country and nominal diameter
Value 2 display	A local display is provided.	Select the measured value that is shown on the local display.	<ul style="list-style-type: none"> ▪ None ▪ Temperature ▪ Mass flow ▪ Corrected volume flow ▪ FAD volume flow * ▪ Volume flow * ▪ Energy flow * ▪ Heat flow * ▪ Density ▪ Flow velocity ▪ Pressure ▪ 2nd temperature delta heat * ▪ Electronic temperature ▪ Totalizer 1 ▪ Totalizer 2 ▪ Totalizer 3 ▪ Current output 1 * ▪ Current output 2 * ▪ Current output 3 * ▪ Current output 4 * 	None
Value 3 display	A local display is provided.	Select the measured value that is shown on the local display.	<ul style="list-style-type: none"> ▪ None ▪ Temperature ▪ Mass flow ▪ Corrected volume flow ▪ FAD volume flow * ▪ Volume flow * ▪ Energy flow * ▪ Heat flow * ▪ Density ▪ Flow velocity ▪ Pressure ▪ 2nd temperature delta heat * ▪ Electronic temperature ▪ Totalizer 1 ▪ Totalizer 2 ▪ Totalizer 3 ▪ Current output 1 * ▪ Current output 2 * ▪ Current output 3 * ▪ Current output 4 * 	None
0% bargraph value 3	A selection was made in the Value 3 display parameter.	Enter 0% value for bar graph display.	Signed floating-point number	0

Parameter	Prerequisite	Description	Selection / User entry	Factory setting
100% bargraph value 3	A selection was made in the Value 3 display parameter.	Enter 100% value for bargraph display.	Signed floating-point number	0
Value 4 display	A local display is provided.	Select the measured value that is shown on the local display.	<ul style="list-style-type: none"> ■ None ■ Temperature ■ Mass flow ■ Corrected volume flow ■ FAD volume flow * ■ Volume flow * ■ Energy flow * ■ Heat flow * ■ Density ■ Flow velocity ■ Pressure ■ 2nd temperature delta heat * ■ Electronic temperature ■ Totalizer 1 ■ Totalizer 2 ■ Totalizer 3 ■ Current output 1 * ■ Current output 2 * ■ Current output 3 * ■ Current output 4 * 	None

* Visibility depends on order options or device settings

9.4.13 Configuring the low flow cut off

The **Low flow cut off** wizard systematically guides the user through all the parameters that must be set to configure low flow cut off.

Navigation

"Setup" menu → Low flow cut off

▶ **Low flow cut off**

Assign process variable	→ 106
On value low flow cutoff	→ 106
Off value low flow cutoff	→ 106

Parameter overview with brief description

Parameter	Prerequisite	Description	Selection / User entry	Factory setting
Assign process variable	–	Select process variable for low flow cut off.	<ul style="list-style-type: none"> ▪ Off ▪ Mass flow ▪ Volume flow ▪ Corrected volume flow ▪ FAD volume flow * 	Mass flow
On value low flow cutoff	A process variable is selected in the Assign process variable parameter (→ 106).	Enter on value for low flow cut off.	Positive floating-point number	Depends on country and nominal diameter
Off value low flow cutoff	A process variable is selected in the Assign process variable parameter (→ 106).	Enter off value for low flow cut off.	0 to 100.0 %	50 %

* Visibility depends on order options or device settings

9.5 Advanced settings







The **Advanced setup** submenu together with its submenus contains parameters for specific settings.

Navigation to the "Advanced setup" submenu

 The number of submenus and parameters can vary depending on the device version. Certain submenus and parameters in these submenus are not described in the Operation Instructions. Instead a description is provided in the Special Documentation for the device (→ "Supplementary documentation" section).

Navigation

"Setup" menu → Advanced setup

▶ Advanced setup		
Enter access code		→  107
▶ Totalizer 1 to n		→  107
▶ Display		→  109
▶ WLAN settings		→  112
▶ Configuration backup		→  114
▶ Administration		→  116

9.5.1 Using the parameter to enter the access code

Navigation

"Setup" menu → Advanced setup

Parameter overview with brief description



Parameter	Description	User entry
Enter access code	Enter access code to disable write protection of parameters.	Max. 16-digit character string comprising numbers, letters and special characters



9.5.2 Configuring the totalizer

In the **"Totalizer 1 to n"** submenu the individual totalizer can be configured.



Navigation

"Setup" menu → Advanced setup → Totalizer 1 to n

▶ Totalizer 1 to n		
Assign process variable		→  108
Unit totalizer 1 to n		→  108

Totalizer operation mode	→  108
Failure mode	→  108
Assign gas	→  108

Parameter overview with brief description

Parameter	Prerequisite	Description	Selection	Factory setting
Assign process variable	–	Select process variable for totalizer.	<ul style="list-style-type: none"> ▪ Off ▪ Mass flow ▪ Corrected volume flow ▪ FAD volume flow * ▪ Volume flow ▪ Energy flow * ▪ Heat flow * 	Mass flow
Unit totalizer 1 to n	A process variable is selected in the Assign process variable parameter (→  108) of the Totalizer 1 to n submenu.	Select process variable totalizer unit.	Unit choose list	kg
Totalizer operation mode	A process variable is selected in the Assign process variable parameter (→  108) of the Totalizer 1 to n submenu.	Select totalizer calculation mode.	<ul style="list-style-type: none"> ▪ Net flow total ▪ Forward flow total ▪ Reverse flow total 	Net flow total
Failure mode	A process variable is selected in the Assign process variable parameter (→  108) of the Totalizer 1 to n submenu.	Define totalizer behavior in alarm condition.	<ul style="list-style-type: none"> ▪ Stop ▪ Actual value ▪ Last valid value 	Stop
Assign gas (Only with order code for "Application package", option EV "Second gas group")	–	Select the gas that the totalizer uses. This gas is only totalized when it is currently active ('Active gas' parameter).	<ul style="list-style-type: none"> ▪ Both gases ▪ Gas ▪ Second gas 	<ul style="list-style-type: none"> ▪ Both gases option (only with order code for "Application package", option EV "Second gas group") ▪ Gas

* Visibility depends on order options or device settings

9.5.3 Carrying out additional display configurations

In the **Display** submenu you can set all the parameters associated with the configuration of the local display.

Navigation

"Setup" menu → Advanced setup → Display

► Display	
Format display	→ 110
Value 1 display	→ 110
0% bargraph value 1	→ 110
100% bargraph value 1	→ 110
Decimal places 1	→ 110
Value 2 display	→ 110
Decimal places 2	→ 111
Value 3 display	→ 111
0% bargraph value 3	→ 111
100% bargraph value 3	→ 111
Decimal places 3	→ 111
Value 4 display	→ 111
Decimal places 4	→ 112
Display language	→ 112
Display interval	→ 112
Display damping	→ 112
Header	→ 112
Header text	→ 112
Separator	→ 112
Backlight	→ 112

Parameter overview with brief description

Parameter	Prerequisite	Description	Selection / User entry	Factory setting
Format display	A local display is provided.	Select how measured values are shown on the display.	<ul style="list-style-type: none"> ▪ 1 value, max. size ▪ 1 bargraph + 1 value ▪ 2 values ▪ 1 value large + 2 values ▪ 4 values 	1 value, max. size
Value 1 display	A local display is provided.	Select the measured value that is shown on the local display.	<ul style="list-style-type: none"> ▪ Temperature ▪ Mass flow ▪ Corrected volume flow ▪ FAD volume flow * ▪ Volume flow ▪ Energy flow * ▪ Heat flow * ▪ Density ▪ Flow velocity ▪ Pressure ▪ 2nd temperature delta heat * ▪ Electronic temperature ▪ Totalizer 1 ▪ Totalizer 2 ▪ Totalizer 3 ▪ Current output 1 * ▪ Current output 2 * ▪ Current output 3 * ▪ Current output 4 * 	Mass flow
0% bargraph value 1	A local display is provided.	Enter 0% value for bar graph display.	Signed floating-point number	0 kg/h
100% bargraph value 1	A local display is provided.	Enter 100% value for bar graph display.	Signed floating-point number	Depends on country and nominal diameter
Decimal places 1	A measured value is specified in the Value 1 display parameter.	Select the number of decimal places for the display value.	<ul style="list-style-type: none"> ▪ x ▪ x.x ▪ x.xx ▪ x.xxx ▪ x.xxxx 	x.xx
Value 2 display	A local display is provided.	Select the measured value that is shown on the local display.	<ul style="list-style-type: none"> ▪ None ▪ Temperature ▪ Mass flow ▪ Corrected volume flow ▪ FAD volume flow * ▪ Volume flow ▪ Energy flow * ▪ Heat flow * ▪ Density ▪ Flow velocity ▪ Pressure ▪ 2nd temperature delta heat * ▪ Electronic temperature ▪ Totalizer 1 ▪ Totalizer 2 ▪ Totalizer 3 ▪ Current output 1 * ▪ Current output 2 * ▪ Current output 3 * ▪ Current output 4 * 	None

Parameter	Prerequisite	Description	Selection / User entry	Factory setting
Decimal places 2	A measured value is specified in the Value 2 display parameter.	Select the number of decimal places for the display value.	<ul style="list-style-type: none"> ■ x ■ x.x ■ x.xx ■ x.xxx ■ x.xxxx 	x.xx
Value 3 display	A local display is provided.	Select the measured value that is shown on the local display.	<ul style="list-style-type: none"> ■ None ■ Temperature ■ Mass flow ■ Corrected volume flow ■ FAD volume flow * ■ Volume flow ■ Energy flow * ■ Heat flow * ■ Density ■ Flow velocity ■ Pressure ■ 2nd temperature delta heat * ■ Electronic temperature ■ Totalizer 1 ■ Totalizer 2 ■ Totalizer 3 ■ Current output 1 * ■ Current output 2 * ■ Current output 3 * ■ Current output 4 * 	None
0% bargraph value 3	A selection was made in the Value 3 display parameter.	Enter 0% value for bar graph display.	Signed floating-point number	0
100% bargraph value 3	A selection was made in the Value 3 display parameter.	Enter 100% value for bar graph display.	Signed floating-point number	0
Decimal places 3	A measured value is specified in the Value 3 display parameter.	Select the number of decimal places for the display value.	<ul style="list-style-type: none"> ■ x ■ x.x ■ x.xx ■ x.xxx ■ x.xxxx 	x.xx
Value 4 display	A local display is provided.	Select the measured value that is shown on the local display.	<ul style="list-style-type: none"> ■ None ■ Temperature ■ Mass flow ■ Corrected volume flow ■ FAD volume flow * ■ Volume flow ■ Energy flow * ■ Heat flow * ■ Density ■ Flow velocity ■ Pressure ■ 2nd temperature delta heat * ■ Electronic temperature ■ Totalizer 1 ■ Totalizer 2 ■ Totalizer 3 ■ Current output 1 * ■ Current output 2 * ■ Current output 3 * ■ Current output 4 * 	None

Parameter	Prerequisite	Description	Selection / User entry	Factory setting
Decimal places 4	A measured value is specified in the Value 4 display parameter.	Select the number of decimal places for the display value.	<ul style="list-style-type: none"> ▪ x ▪ x.x ▪ x.xx ▪ x.xxx ▪ x.xxxx 	x.xx
Display language	A local display is provided.	Set display language.	<ul style="list-style-type: none"> ▪ English ▪ Deutsch ▪ Français ▪ Español ▪ Italiano ▪ Nederlands ▪ Portuguesa ▪ Polski ▪ русский язык (Russian) ▪ Svenska ▪ Türkçe ▪ 中文 (Chinese) ▪ 日本語 (Japanese) ▪ 한국어 (Korean) ▪ العربية (Arabic) * ▪ Bahasa Indonesia ▪ ภาษาไทย (Thai) * ▪ tiếng Việt (Vietnamese) ▪ čeština (Czech) 	English (alternatively, the ordered language is preset in the device)
Display interval	A local display is provided.	Set time measured values are shown on display if display alternates between values.	1 to 10 s	5 s
Display damping	A local display is provided.	Set display reaction time to fluctuations in the measured value.	0.0 to 999.9 s	0.0 s
Header	A local display is provided.	Select header contents on local display.	<ul style="list-style-type: none"> ▪ Device tag ▪ Free text 	Device tag
Header text	In the Header parameter, the Free text option is selected.	Enter display header text.	Max. 12 characters such as letters, numbers or special characters (e.g. @, %, /)	-----
Separator	A local display is provided.	Select decimal separator for displaying numerical values.	<ul style="list-style-type: none"> ▪ . (point) ▪ , (comma) 	. (point)
Backlight	One of the following conditions is met: <ul style="list-style-type: none"> ▪ Order code for "Display; operation", option F "4-line, illum.; touch control" ▪ Order code for "Display; operation", option G "4-line, illum.; touch control +WLAN" 	Switch the local display backlight on and off.	<ul style="list-style-type: none"> ▪ Disable ▪ Enable 	Enable

* Visibility depends on order options or device settings

9.5.4 WLAN configuration

The **WLAN Settings** submenu guides the user systematically through all the parameters that have to be set for the WLAN configuration.



Navigation

"Setup" menu → Advanced setup → WLAN settings

▶ WLAN settings	
WLAN	→ ⓘ 113
WLAN mode	→ ⓘ 113
SSID name	→ ⓘ 113
Network security	→ ⓘ 114
Security identification	→ ⓘ 114
User name	→ ⓘ 114
WLAN password	→ ⓘ 114
WLAN IP address	→ ⓘ 114
WLAN MAC address	→ ⓘ 114
WLAN passphrase	→ ⓘ 114
Assign SSID name	→ ⓘ 114
SSID name	→ ⓘ 114
Connection state	→ ⓘ 114
Received signal strength	→ ⓘ 114

Parameter overview with brief description

Parameter	Prerequisite	Description	Selection / User entry / User interface	Factory setting
WLAN	–	Switch WLAN on and off.	<ul style="list-style-type: none"> ■ Disable ■ Enable 	Enable
WLAN mode	–	Select WLAN mode.	<ul style="list-style-type: none"> ■ WLAN access point ■ WLAN Client 	WLAN access point
SSID name	The client is activated.	Enter the user-defined SSID name (max. 32 characters).	–	–

Parameter	Prerequisite	Description	Selection / User entry / User interface	Factory setting
Network security	–	Select the security type of the WLAN network.	<ul style="list-style-type: none"> ▪ Unsecured ▪ WPA2-PSK ▪ EAP-PEAP with MSCHAPv2 * ▪ EAP-PEAP MSCHAPv2 no server authentic. * ▪ EAP-TLS * 	WPA2-PSK
Security identification	–	Select security settings and download these settings via menu Data management > Security > WLAN.	<ul style="list-style-type: none"> ▪ Trusted issuer certificate ▪ Device certificate ▪ Device private key 	–
User name	–	Enter user name.	–	–
WLAN password	–	Enter WLAN password.	–	–
WLAN IP address	–	Enter IP address of the WLAN interface of the device.	4 octet: 0 to 255 (in the particular octet)	192.168.1.212
WLAN MAC address	–	Enter MAC address of the WLAN interface of the device.	Unique 12-digit character string comprising letters and numbers	Each measuring device is given an individual address.
WLAN passphrase	The WPA2-PSK option is selected in the Security type parameter.	Enter the network key (8 to 32 characters).  The network key supplied with the device should be changed during commissioning for security reasons.	8 to 32-digit character string comprising numbers, letters and special characters (without spaces)	Serial number of the measuring device (e.g. L100A802000)
Assign SSID name	–	Select which name will be used for SSID: device tag or user-defined name.	<ul style="list-style-type: none"> ▪ Device tag ▪ User-defined 	User-defined
SSID name	<ul style="list-style-type: none"> ▪ The User-defined option is selected in the Assign SSID name parameter. ▪ The WLAN access point option is selected in the WLAN mode parameter. 	Enter the user-defined SSID name (max. 32 characters).  The user-defined SSID name may only be assigned once. If the SSID name is assigned more than once, the devices can interfere with one another.	Max. 32-digit character string comprising numbers, letters and special characters	
Connection state	–	Displays the connection status.	<ul style="list-style-type: none"> ▪ Connected ▪ Not connected 	Not connected
Received signal strength	–	Shows the received signal strength.	<ul style="list-style-type: none"> ▪ Low ▪ Medium ▪ High 	High

* Visibility depends on order options or device settings

9.5.5 Configuration management

After commissioning, you can save the current device configuration or restore the previous device configuration.

You can do so using the **Configuration management** parameter and the related options found in the **Configuration backup** submenu.

Navigation

"Setup" menu → Advanced setup → Configuration backup

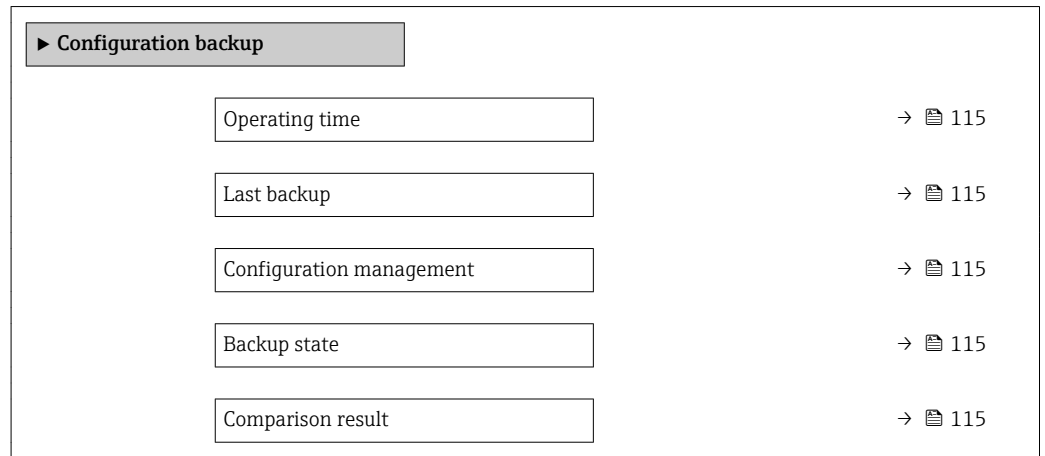

Parameter overview with brief description

Parameter	Description	User interface / Selection	Factory setting
Operating time	Indicates how long the device has been in operation.	Days (d), hours (h), minutes (m) and seconds (s)	–
Last backup	Shows when the last data backup was saved to HistoROM backup.	Days (d), hours (h), minutes (m) and seconds (s)	–
Configuration management	Select action for managing the device data in the HistoROM backup.	<ul style="list-style-type: none"> ■ Cancel ■ Execute backup ■ Restore * ■ Compare * ■ Clear backup data 	Cancel
Backup state	Shows the current status of data saving or restoring.	<ul style="list-style-type: none"> ■ None ■ Backup in progress ■ Restoring in progress ■ Delete in progress ■ Compare in progress ■ Restoring failed ■ Backup failed 	None
Comparison result	Comparison of current device data with HistoROM backup.	<ul style="list-style-type: none"> ■ Settings identical ■ Settings not identical ■ No backup available ■ Backup settings corrupt ■ Check not done ■ Dataset incompatible 	Check not done

* Visibility depends on order options or device settings

Function scope of the "Configuration management" parameter

Options	Description
Cancel	No action is executed and the user exits the parameter.
Execute backup	A backup copy of the current device configuration is saved from the HistoROM backup to the memory of the device. The backup copy includes the transmitter data of the device.
Restore	The last backup copy of the device configuration is restored from the device memory to the device's HistoROM backup. The backup copy includes the transmitter data of the device.

Options	Description
Compare	The device configuration saved in the device memory is compared with the current device configuration of the HistoROM backup.
Clear backup data	The backup copy of the device configuration is deleted from the memory of the device.

 **HistoROM backup**
 A HistoROM is a "non-volatile" device memory in the form of an EEPROM.

 While this action is in progress, the configuration cannot be edited via the local display and a message on the processing status appears on the display.

9.5.6 Using parameters for device administration

The **Administration** submenu systematically guides the user through all the parameters that can be used for device administration purposes.

Navigation

"Setup" menu → Advanced setup → Administration

▶ Administration		
▶ Define access code		→ ⓘ 116
▶ Reset access code		→ ⓘ 117
Device reset		→ ⓘ 117

Using the parameter to define the access code

Navigation

"Setup" menu → Advanced setup → Administration → Define access code

▶ Define access code		
Define access code		→ ⓘ 116
Confirm access code		→ ⓘ 116

Parameter overview with brief description

Parameter	Description	User entry
Define access code	Restrict write-access to parameters to protect the configuration of the device against unintentional changes.	Max. 16-digit character string comprising numbers, letters and special characters
Confirm access code	Confirm the entered access code.	Max. 16-digit character string comprising numbers, letters and special characters

Using the parameter to reset the access code

Navigation

"Setup" menu → Advanced setup → Administration → Reset access code

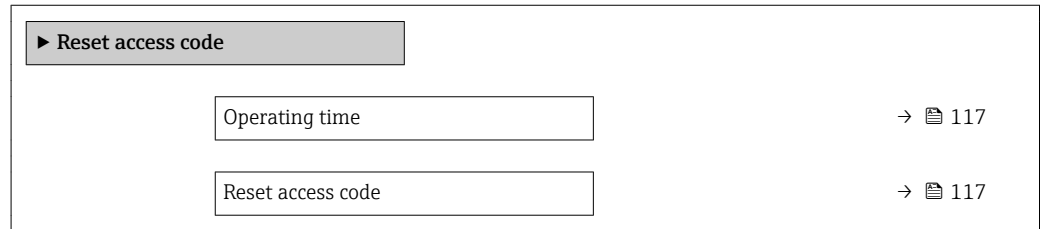

Parameter overview with brief description

Parameter	Description	User interface / User entry	Factory setting
Operating time	Indicates how long the device has been in operation.	Days (d), hours (h), minutes (m) and seconds (s)	-
Reset access code	Reset access code to factory settings.  For a reset code, contact your Endress+Hauser service organization. The reset code can only be entered via: <ul style="list-style-type: none"> ▪ Web browser ▪ DeviceCare, FieldCare (via service interface CDI-RJ45) ▪ Fieldbus 	Character string comprising numbers, letters and special characters	0x00

Using the parameter to reset the device

Navigation

"Setup" menu → Advanced setup → Administration

Parameter overview with brief description

Parameter	Description	Selection	Factory setting
Device reset	Reset the device configuration - either entirely or in part - to a defined state.	<ul style="list-style-type: none"> ▪ Cancel ▪ To delivery settings ▪ Restart device ▪ Restore S-DAT backup * 	Cancel

* Visibility depends on order options or device settings

9.5.7 In-situ adjustment

In-situ adjustment is used to adjust the flow output by the measuring device to the real flow of the facility. Flow profiles can be distorted by facility parts such as pipe elbows, extensions, reductions or valves. A distorted flow profile can, in turn, negatively impact the accuracy of the measuring device. By taking into consideration the actual process-specific conditions at the facility, including any effects from installation, in-situ adjustment provides flow display that is adapted to the local conditions.

In-situ adjustment can lead to better measurement results in the following cases:

- Process-specific facility conditions / installation effects
 - If the flow profile is distorted
 - For unfavorable inlet and outlet conditions
 - If the gas is unknown
 - If it is not possible to use a flow conditioner to rectify the distorted flow profile
 - If process conditions deviate significantly from reference conditions (pressure and temperature conditions of factory calibration)
- Third-party adjustments with the process gas actually used

In-situ adjustment has the following specific features:

- Can be used for both unidirectional and bidirectional sensors
- Can be defined for up to 16 flow points (for the entire operating range)
- At least one flow point is required for the adjustment but the general principle is that the more flow points that are defined, the better the measuring performance
- Measuring device can be configured without interrupting the process
- The measuring device takes account of the choice of process gas and the actual process conditions during the measurement
- The flow value can be entered manually via a display or an operating interface, or a flow value from a reference device can be read into the measuring device via a current input or bus communication

Prerequisites for optimum in-situ adjustment

- The accuracy of the flow reference used determines the performance of the measuring device adjusted in-situ. For this reason, the use of a reference device with a traceable calibration is recommended
- Calibration points all at the same temperature and pressure conditions
- Compositions of gases or gas mixtures are made available to the measuring device as these compositions are used for pressure and temperature compensation
- Precise pressure specifications are important if a volume flowmeter is used as the reference device
- If the flow values are indicated in corrected volume flow, it is important that the standard reference conditions in the reference device and in the device are identical



- For optimum results, it is advisable to use a reference device with traceable calibration for the adjustment.
 - If a reference device is not available, a fan characteristic curve, for example, can act as the reference

Performing in-situ adjustment

1. Select the gas: Expert → Sensor → Measurement mode → Gas → Gas
 - ↳ This entry is important for measuring device pressure and temperature compensation.
2. Activate in-situ adjustment: Expert → Sensor → In-situ adjustment → Activate in-situ adjustment
3. Confirm selection: Yes
 - ↳ If an in-situ adjustment already exists, these adjustment points are loaded. An existing adjustment (an entire series of flow points) can be deleted from the measuring device using the "Clear values" function.
4. Select the reference value: Expert → Sensor → In-situ adjustment → Select flow reference
 - ↳ If volume flow is selected, it is important that the process pressure entered in the measuring device is as accurate as possible. In the case of corrected volume flow or FAD volume flow, the defined reference operating conditions must match those of the reference measuring device.

5. Select the entry method for the reference value: Expert → Sensor → In-situ adjustment → Input type reference value
 - ↳ If "Manual" is selected, the operator must enter the flow value manually via the display (or other operating interface). However, if "Current input" or "External value" (via bus communication) is selected, the current flow values are displayed as read only reference values. The available entry modes depend on the I/O modules available.

The user can first approach the flow points with the facility. As soon as a desired flow value is reached, the value can either be saved by confirming the value or be entered as a fixed value by hand.

 The entry method depends on the selected entry mode.

The measured flow value is checked to determine its validity on the basis of the following criteria:

- Average absolute deviation of the flow value
- Standard deviation of the flow value

If a criterion is not met, the value is rejected and the message "Invalid" is displayed. If both criterion are met, the message "Passed" is displayed. If the flow value fluctuates too much, "Unstable" is displayed. If an existing adjustment is "readjusted", and with a maximum of 16 defined flow values, the flow value that is closest to the new adjusted value is replaced. Here, "Replaced" is displayed as the status.

 The user can also add a description to the adjustment. Three different text fields, with 16 alphanumeric characters per field, are available for this purpose. It is advisable to use the text fields to identify the adjustment using the name of the gas/gas mixture and the process conditions of the adjustment. If the in-situ adjustment is adjusted by a calibration laboratory with the gas that is actually used by the operator, it is advisable to also include the name of the laboratory, the date of the adjustment and the name of the operator in the description.

Special cases

Individual flow point

A maximum of 16 flow points can be defined. However, in certain situations it may not always be possible to adjust multiple flow points. In such cases, the measuring device can be adjusted with just a few operating points. The minimum number of flow points that are required is one. If only one operating point is adjusted, the measuring device uses default values to replace the missing adjustment values. Therefore, the operator should be aware that the accuracy of the in-situ adjustment can suffer when just one flow point is defined if the measured flow is not close to the adjustment value.

Bidirectional flow

















Measuring devices that are equipped with the bidirectional option can be adjusted in situ in both flow directions or in just one flow direction, as required. If the measuring device is only adjusted in one direction, it is important that the adjustment is in the positive direction (forward flow) as these adjustment points are automatically replicated to the negative direction (reverse flow).

Unknown gas composition

If the gas or gas mixture is unknown, or if the gas composition cannot be defined by the standard gas selection, the user can define the process gas as "Air". This method has the disadvantage that compensation in the event of variations in the pressure and temperature cannot be guaranteed. If the operator is not sure of the exact composition of the gas but can make an approximate guess, it is recommended to use this approximate gas composition instead of air.

"In-situ adjustment" submenu**Navigation**

"Expert" menu → Sensor → In-situ adjustment

► In-situ adjustment	
Activate in-situ adjustment (17360)	→  121
Input type reference value (17351)	→  121
Delete values (17355)	→  121
Confirm (17356)	→  121
Select flow reference (17354)	→  121
Stability check (17366)	→  121
Actual flow value (17365)	→  121
External reference value (17352)	→  121
Reference value (17353)	→  121
Apply value (17364)	→  121
Status (17367)	→  121
Description 1 (17359)	→  121
Description 2 (17358)	→  121
Description 3 (17357)	→  121
Description 4 (17002)	→  121
► Adjustment values in use	→  122

Parameter overview with brief description

Parameter	Description	Selection / User interface / User entry	Factory setting
Activate in-situ adjustment	Activate the in-situ adjustment. The points stored by the user are used for the in-situ adjustment.	<ul style="list-style-type: none"> ■ No ■ Yes 	No
Input type reference value	Select input type for the reference value.	<ul style="list-style-type: none"> ■ Off ■ Manual ■ Current input 1 * ■ Current input 2 * ■ Current input 3 * ■ External value * 	Off
Delete values	Delete previous adjustment values and descriptions.	<ul style="list-style-type: none"> ■ No ■ Yes 	No
Confirm	Confirm deletion.	<ul style="list-style-type: none"> ■ No ■ Yes 	No
Select flow reference	Select process variable. This process variable is used as reference value for the in situ adjustment.	<ul style="list-style-type: none"> ■ Mass flow ■ Corrected volume flow ■ FAD volume flow * ■ Volume flow 	Mass flow
Stability check	Activate stability check. New adjustment value is only accepted when the measurement is stable.	<ul style="list-style-type: none"> ■ No ■ Yes 	Yes
Actual flow value	Shows the actual flow in relation to the maximum, factory-measured value that is adapted to the actual process conditions.	-2 000 to 2 000 %	0 %
External reference value	Shows the external reference value for the in situ adjustment.	Signed floating-point number	0 kg/h
Reference value	Enter fixed value as reference value used for the in situ adjustment.	Signed floating-point number	0 kg/h
Apply value	Apply the actual value.	<ul style="list-style-type: none"> ■ No ■ Yes 	No
Status	Shows the validity of the actual reference value.	<ul style="list-style-type: none"> ■ Passed ■ Replaced ■ Unstable ■ Invalid 	Passed
Description 1	Description for in-situ adjustment: e.g. facility, operator, date.	-	-
Description 2	Description for in-situ adjustment: e.g. facility, operator, date.	-	-
Description 3	Description for in-situ adjustment: e.g. facility, operator, date.	-	-
Description 4	Description for in-situ adjustment: e.g. facility, operator, date.	-	-

* Visibility depends on order options or device settings

"Adjustment values in use" submenu

Navigation

"Expert" menu → Sensor → In-situ adjustment → Adjustment values in use

▶ Adjustment values in use	
Gas description 1/2 (17361)	→ 123
Gas description 2/2 (17362)	→ 123
Flow value 1 (17368)	→ 123
Flow value 2 (17369)	→ 123
Flow value 3 (17370)	→ 123
Flow value 4 (17371)	→ 123
Flow value 5 (17372)	→ 123
Flow value 6 (17373)	→ 123
Flow value 7 (17374)	→ 123
Flow value 8 (17375)	→ 123
Flow value 9 (17376)	→ 123
Flow value 10 (17377)	→ 123
Flow value 11 (17378)	→ 123
Flow value 12 (17379)	→ 123
Flow value 13 (17380)	→ 123
Flow value 14 (17381)	→ 123
Flow value 15 (17382)	→ 123
Flow value 16 (17383)	→ 123

Parameter overview with brief description

Parameter	Description	User interface	Factory setting
Gas description 1/2	Shows the 1st part of the description of the set gas used in the in-situ adjustment.	-	-
Gas description 2/2	Shows the 2nd part of the description of the set gas used in the in-situ adjustment.	-	-
Flow value 1	Shows the stored flow value in relation to the maximum, factory-measured value that is adapted to the actual process conditions.	-2 000 to 2 000 %	0 %
Flow value 2	Shows the stored flow value in relation to the maximum, factory-measured value that is adapted to the actual process conditions.	-2 000 to 2 000 %	0 %
Flow value 3	Shows the stored flow value in relation to the maximum, factory-measured value that is adapted to the actual process conditions.	-2 000 to 2 000 %	0 %
Flow value 4	Shows the stored flow value in relation to the maximum, factory-measured value that is adapted to the actual process conditions.	-2 000 to 2 000 %	0 %
Flow value 5	Shows the stored flow value in relation to the maximum, factory-measured value that is adapted to the actual process conditions.	-2 000 to 2 000 %	0 %
Flow value 6	Shows the stored flow value in relation to the maximum, factory-measured value that is adapted to the actual process conditions.	-2 000 to 2 000 %	0 %
Flow value 7	Shows the stored flow value in relation to the maximum, factory-measured value that is adapted to the actual process conditions.	-2 000 to 2 000 %	0 %
Flow value 8	Shows the stored flow value in relation to the maximum, factory-measured value that is adapted to the actual process conditions.	-2 000 to 2 000 %	0 %
Flow value 9	Shows the stored flow value in relation to the maximum, factory-measured value that is adapted to the actual process conditions.	-2 000 to 2 000 %	0 %
Flow value 10	Shows the stored flow value in relation to the maximum, factory-measured value that is adapted to the actual process conditions.	-2 000 to 2 000 %	0 %
Flow value 11	Shows the stored flow value in relation to the maximum, factory-measured value that is adapted to the actual process conditions.	-2 000 to 2 000 %	0 %
Flow value 12	Shows the stored flow value in relation to the maximum, factory-measured value that is adapted to the actual process conditions.	-2 000 to 2 000 %	0 %
Flow value 13	Shows the stored flow value in relation to the maximum, factory-measured value that is adapted to the actual process conditions.	-2 000 to 2 000 %	0 %
Flow value 14	Shows the stored flow value in relation to the maximum, factory-measured value that is adapted to the actual process conditions.	-2 000 to 2 000 %	0 %
Flow value 15	Shows the stored flow value in relation to the maximum, factory-measured value that is adapted to the actual process conditions.	-2 000 to 2 000 %	0 %
Flow value 16	Shows the stored flow value in relation to the maximum, factory-measured value that is adapted to the actual process conditions.	-2 000 to 2 000 %	0 %

9.6 Configuration management

After commissioning, you can save the current device configuration or restore the previous device configuration.

You can do so using the **Configuration management** parameter and the related options found in the **Configuration backup** submenu.

Navigation

"Setup" menu → Advanced setup → Configuration backup

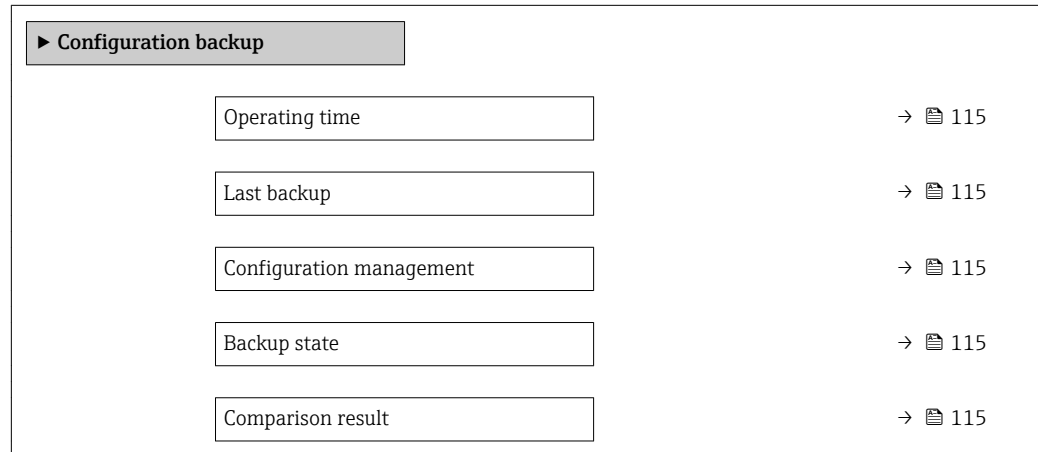

Parameter overview with brief description

Parameter	Description	User interface / Selection	Factory setting
Operating time	Indicates how long the device has been in operation.	Days (d), hours (h), minutes (m) and seconds (s)	–
Last backup	Shows when the last data backup was saved to HistoROM backup.	Days (d), hours (h), minutes (m) and seconds (s)	–
Configuration management	Select action for managing the device data in the HistoROM backup.	<ul style="list-style-type: none"> ▪ Cancel ▪ Execute backup ▪ Restore ▪ Compare ▪ Clear backup data 	Cancel
Backup state	Shows the current status of data saving or restoring.	<ul style="list-style-type: none"> ▪ None ▪ Backup in progress ▪ Restoring in progress ▪ Delete in progress ▪ Compare in progress ▪ Restoring failed ▪ Backup failed 	None
Comparison result	Comparison of current device data with HistoROM backup.	<ul style="list-style-type: none"> ▪ Settings identical ▪ Settings not identical ▪ No backup available ▪ Backup settings corrupt ▪ Check not done ▪ Dataset incompatible 	Check not done

9.6.1 Function scope of the "Configuration management" parameter

Options	Description
Cancel	No action is executed and the user exits the parameter.
Execute backup	A backup copy of the current device configuration is saved from the HistoROM backup to the memory of the device. The backup copy includes the transmitter data of the device.
Restore	The last backup copy of the device configuration is restored from the device memory to the device's HistoROM backup. The backup copy includes the transmitter data of the device.
Compare	The device configuration saved in the device memory is compared with the current device configuration of the HistoROM backup.
Clear backup data	The backup copy of the device configuration is deleted from the memory of the device.

 **HistoROM backup**

A HistoROM is a "non-volatile" device memory in the form of an EEPROM.



While this action is in progress, the configuration cannot be edited via the local display and a message on the processing status appears on the display.

9.7 Simulation

The **Simulation** submenu enables you to simulate, without a real flow situation, various process variables in the process and the device alarm mode and to verify downstream signal chains (switching valves or closed-control loops).

Navigation

"Diagnostics" menu → Simulation

▶ **Simulation**

- Assign simulation process variable

→  126
- Process variable value

→  126
- Current input 1 to n simulation

→  126
- Value current input 1 to n

→  126
- Status input simulation 1 to n

→  126
- Input signal level 1 to n









→  126
- Current output 1 to n simulation

→  126
- Value current output 1 to n

→  126
- Frequency output simulation 1 to n



→  126
- Frequency value 1 to n

→  127

Pulse output simulation 1 to n	→  127
Pulse value 1 to n	→  127
Switch output simulation 1 to n	→  127
Switch status 1 to n	→  127
Relay output 1 to n simulation	→  127
Switch status 1 to n	→  127
Device alarm simulation	→  127
Diagnostic event category	→  127
Diagnostic event simulation	→  127

Parameter overview with brief description



Parameter	Prerequisite	Description	Selection / User entry	Factory setting
Assign simulation process variable	–	Select a process variable for the simulation process that is activated.	<ul style="list-style-type: none"> ▪ Off ▪ Temperature ▪ Mass flow ▪ Corrected volume flow ▪ FAD volume flow * ▪ Volume flow * ▪ Energy flow * ▪ Heat flow * ▪ Density ▪ Flow velocity 	Off
Process variable value	A process variable is selected in the Assign simulation process variable parameter (→  126).	Enter the simulation value for the selected process variable.	Depends on the process variable selected	0
Current input 1 to n simulation	–	Switch simulation of the current input on and off.	<ul style="list-style-type: none"> ▪ Off ▪ On 	Off
Value current input 1 to n	In the Current input 1 to n simulation parameter, the On option is selected.	Enter the current value for simulation.	0 to 22.5 mA	0 mA
Status input simulation 1 to n	–	Switch simulation of the status input on and off.	<ul style="list-style-type: none"> ▪ Off ▪ On 	Off
Input signal level 1 to n	In the Status input simulation parameter, the On option is selected.	Select the signal level for the simulation of the status input.	<ul style="list-style-type: none"> ▪ High ▪ Low 	High
Current output 1 to n simulation	–	Switch the simulation of the current output on and off.	<ul style="list-style-type: none"> ▪ Off ▪ On 	Off
Value current output 1 to n	In the Current output 1 to n simulation parameter, the On option is selected.	Enter the current value for simulation.	3.59 to 22.5 mA	3.59 mA
Frequency output simulation 1 to n	In the Operating mode parameter, the Frequency option is selected.	Switch the simulation of the frequency output on and off.	<ul style="list-style-type: none"> ▪ Off ▪ On 	Off

Parameter	Prerequisite	Description	Selection / User entry	Factory setting
Frequency value 1 to n	In the Frequency output simulation 1 to n parameter, the On option is selected.	Enter the frequency value for the simulation.	0.0 to 12 500.0 Hz	0.0 Hz
Pulse output simulation 1 to n	In the Operating mode parameter, the Pulse option is selected.	Set and switch off the pulse output simulation.  For Fixed value option: Pulse width parameter (→  96) defines the pulse width of the pulses output.	<ul style="list-style-type: none"> ▪ Off ▪ Fixed value ▪ Down-counting value 	Off
Pulse value 1 to n	In the Pulse output simulation 1 to n parameter, the Down-counting value option is selected.	Enter the number of pulses for simulation.	0 to 65 535	0
Switch output simulation 1 to n	In the Operating mode parameter, the Switch option is selected.	Switch the simulation of the switch output on and off.	<ul style="list-style-type: none"> ▪ Off ▪ On 	Off
Switch status 1 to n	–	Select the status of the status output for the simulation.	<ul style="list-style-type: none"> ▪ Open ▪ Closed 	Open
Relay output 1 to n simulation	–	Switch simulation of the relay output on and off.	<ul style="list-style-type: none"> ▪ Off ▪ On 	Off
Switch status 1 to n	The On option is selected in the Switch output simulation 1 to n parameter parameter.	Select status of the relay output for the simulation.	<ul style="list-style-type: none"> ▪ Open ▪ Closed 	Open
Device alarm simulation	–	Switch the device alarm on and off.	<ul style="list-style-type: none"> ▪ Off ▪ On 	Off
Diagnostic event category	–	Select a diagnostic event category.	<ul style="list-style-type: none"> ▪ Sensor ▪ Electronics ▪ Configuration ▪ Process 	Process
Diagnostic event simulation	–	Select a diagnostic event to simulate this event.	<ul style="list-style-type: none"> ▪ Off ▪ Diagnostic event picklist (depends on the category selected) 	Off

* Visibility depends on order options or device settings

9.8 Protecting settings from unauthorized access

The following write protection options exist in order to protect the configuration of the measuring device from unintentional modification:



- Protect access to parameters via access code →  127
- Protect access to local operation via key locking →  62
- Protect access to measuring device via write protection switch →  129

9.8.1 Write protection via access code



The effects of the user-specific access code are as follows:

- Via local operation, the parameters for the measuring device configuration are write-protected and their values can no longer be changed.
- Device access is protected via the Web browser, as are the parameters for the measuring device configuration.
- Device access is protected via FieldCare or DeviceCare (via CDI-RJ45 service interface), as are the parameters for the measuring device configuration.

Defining the access code via local display

1. Navigate to the **Define access code** parameter (→  116).
2. Define a max. 16-digit character string comprising numbers, letters and special characters as the access code.
3. Enter the access code again in the **Confirm access code** parameter (→  116) to confirm the code.
 - ↳ The -symbol appears in front of all write-protected parameters.

The device automatically locks the write-protected parameters again if a key is not pressed for 10 minutes in the navigation and editing view. The device locks the write-protected parameters automatically after 60 s if the user skips back to the operational display mode from the navigation and editing view.



-  If parameter write protection is activated via an access code, it can also only be deactivated via this access code →  61.
 - The user role with which the user is currently logged on via the local display →  61 is indicated by the **Access status** parameter. Navigation path: Operation → Access status

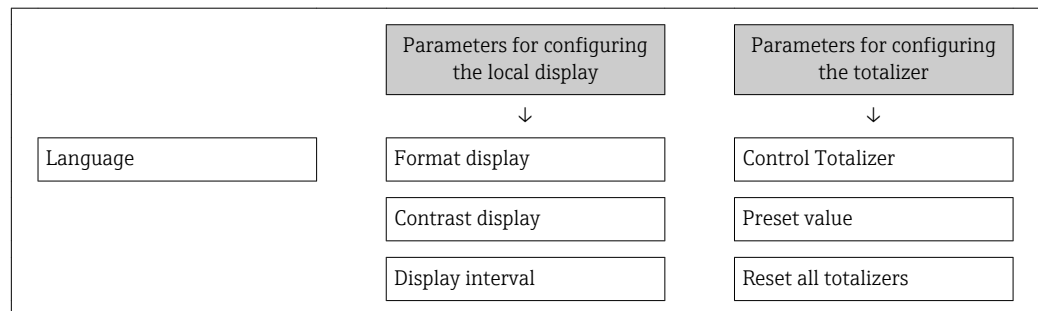

Parameters which can always be modified via the local display

Certain parameters that do not affect the measurement are excepted from parameter write protection via the local display. Despite the user-specific access code, they can always be modified, even if the other parameters are locked.



Defining the access code via the Web browser

1. Navigate to the **Define access code** parameter (→  116).
2. Define a max. 16-digit numeric code as an access code.
3. Enter the access code again in the **Confirm access code** parameter (→  116) to confirm the code.
 - ↳ The Web browser switches to the login page.



-  If no action is performed for 10 minutes, the Web browser automatically returns to the login page.
-  If parameter write protection is activated via an access code, it can also only be deactivated via this access code →  61.
 - The user role with which the user is currently logged on via Web browser is indicated by the **Access status** parameter. Navigation path: Operation → Access status

Resetting the access code

If you misplace the user-specific access code, it is possible to reset the code to the factory setting. A reset code must be entered for this purpose. The user-specific access code can then be defined again afterwards.

Via Web browser, FieldCare, DeviceCare (via CDI-RJ45 service interface), fieldbus

i For a reset code, contact your Endress+Hauser service organization.

1. Navigate to the **Reset access code** parameter (→  117).
2. Enter the reset code.
 - ↳ The access code has been reset to the factory setting **0000**. It can be redefined →  128.

9.8.2 Write protection via write protection switch

Unlike parameter write protection via a user-specific access code, this allows write access to the entire operating menu - except for the **"Contrast display" parameter** - to be locked.

The parameter values are now read only and cannot be edited any more (exception **"Contrast display" parameter**):

- Via local display
- Via MODBUS RS485 protocol

Proline 500 – digital

⚠ WARNING

Excessive tightening torque applied to the fixing screws!

Risk of damaging the plastic transmitter.

- ▶ Tighten the fixing screws as per the tightening torque: 2 Nm (1.5 lbf ft)

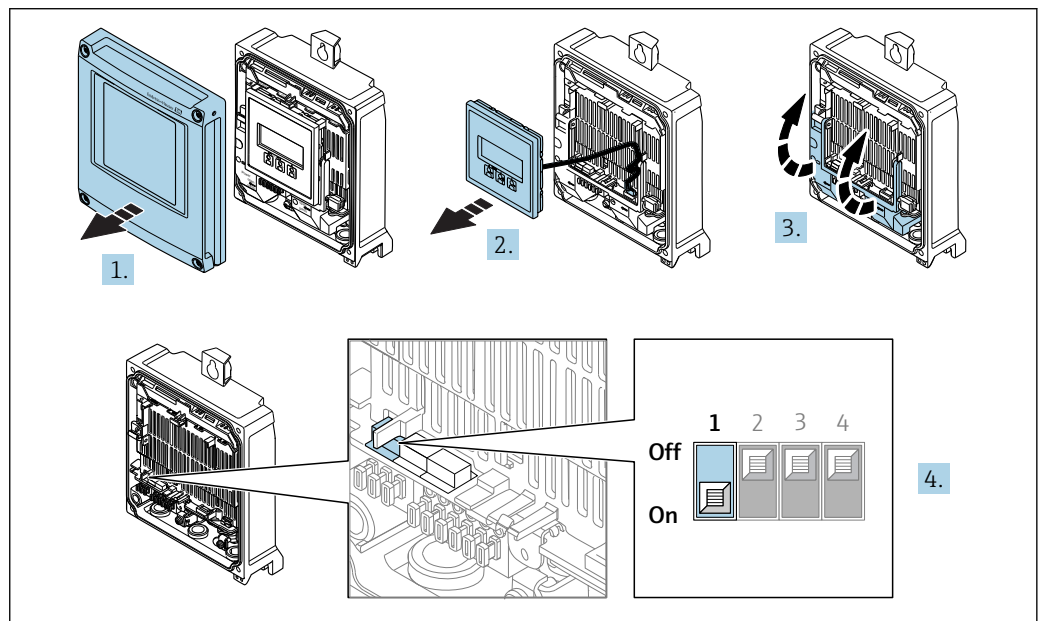

A0029673

1. Open the housing cover.
2. Remove the display module.
3. Fold open the terminal cover.

4. Setting the write protection (WP) switch on the main electronics module to the **ON** position enables hardware write protection.
 - ↳ In the **Locking status** parameter the **Hardware locked** option is displayed → 131. In addition, on the local display the -symbol appears in front of the parameters in the header of the operational display and in the navigation view.

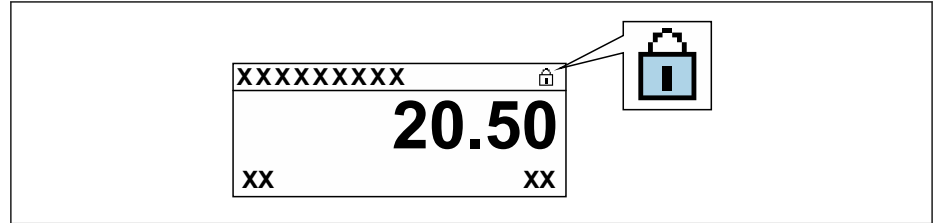

5. Setting the write protection (WP) switch on the main electronics module to the **OFF** position (factory setting) disables hardware write protection.
 - ↳ No option is displayed in the **Locking status** parameter → 131. On the local display, the -symbol disappears from in front of the parameters in the header of the operational display and in the navigation view.



10 Operation

10.1 Reading the device locking status

Device active write protection: **Locking status** parameter



Operation → Locking status

Function scope of the "Locking status" parameter

Options	Description
None	The access status displayed in the Access status parameter applies →  61. Only appears on local display.
Hardware locked	The DIP switch for hardware locking is activated on the PCB board. This locks write access to the parameters (e.g. via local display or operating tool) →  129.
Temporarily locked	Write access to the parameters is temporarily locked on account of internal processes running in the device (e.g. data upload/download, reset etc.). Once the internal processing has been completed, the parameters can be changed once again.



10.2 Adjusting the operating language

 Detailed information:

- To configure the operating language →  79
- For information on the operating languages supported by the measuring device →  190

10.3 Configuring the display

Detailed information:





- On the basic settings for the local display →  102
- On the advanced settings for the local display →  109

10.4 Reading measured values

With the **Measured values** submenu, it is possible to read all the measured values.

Navigation

"Diagnostics" menu → Measured values

▶ Measured values	
▶ Process variables	→  132
▶ System values	→  133
▶ Input values	→  134
▶ Output values	→  135
▶ Totalizer	→  133

10.4.1 Process variables

The contains all the parameters needed to display the current measured values for each process variable.

Navigation

"Diagnostics" menu → Measured values → Process variables

► Process variables	
Mass flow	→ ⓘ 132
Corrected volume flow	→ ⓘ 132
Volume flow	→ ⓘ 132
FAD volume flow	→ ⓘ 132
Energy flow	→ ⓘ 133
Temperature	→ ⓘ 133
Density	→ ⓘ 133
Flow velocity	→ ⓘ 133
Heat flow	→ ⓘ 133

Parameter overview with brief description

Parameter	Prerequisite	Description	User interface
Mass flow	–	Displays the mass flow that is currently measured. <i>Dependency</i> The unit is taken from the Mass flow unit parameter (→ ⓘ 89).	Signed floating-point number
Corrected volume flow	–	Displays the corrected volume flow that is currently calculated. <i>Dependency</i> The unit is taken from the Corrected volume flow unit parameter (→ ⓘ 89).	Signed floating-point number
Volume flow	–	Displays the volume flow that is currently measured. <i>Dependency</i> The unit is taken from the Volume flow unit parameter (→ ⓘ 89).	Signed floating-point number
FAD volume flow	The Air or compressed air option is selected in the Measurement application parameter parameter.	Displays the FAD volume flow that is currently calculated. <i>Dependency</i> The unit is taken from the FAD volume flow unit parameter (→ ⓘ 89).	Signed floating-point number

Parameter	Prerequisite	Description	User interface
Energy flow	The Energy option is selected in the Measurement application parameter parameter.	Shows the energy flow currently calculated.	Signed floating-point number
Temperature	–	Displays the temperature that is currently measured. <i>Dependency</i> The unit is taken from the Temperature unit parameter (→ 90).	Signed floating-point number
Density	–	Shows the density currently calculated.	Signed floating-point number
Flow velocity	–	Shows the flow velocity currently calculated.	Signed floating-point number
Heat flow	The Energy option is selected in the Measurement application parameter parameter.	Shows the heat flow currently calculated.	Signed floating-point number

10.4.2 System values

The **System values** submenu contains all the parameters needed to display the current measured values for every system value.

Diagnostics → Measured values → System values

Navigation

"Diagnostics" menu → Measured values → System values

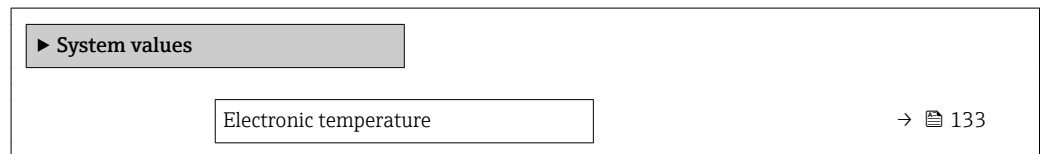

Parameter overview with brief description

Parameter	Description	User interface
Electronic temperature	Indication of the current temperature of the electronics.	Signed floating-point number

10.4.3 "Totalizer" submenu

The **Totalizer** submenu contains all the parameters needed to display the current measured values for every totalizer.

Navigation

"Diagnostics" menu → Measured values → Totalizer

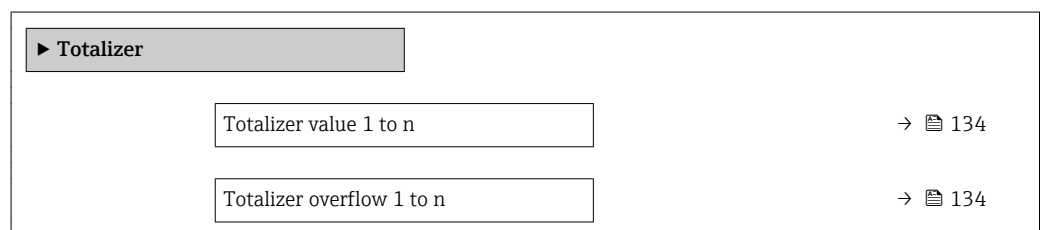

Parameter overview with brief description

Parameter	Description	User interface
Totalizer value 1 to n	Displays the current totalizer counter value.	Signed floating-point number
Totalizer overflow 1 to n	Displays the current totalizer overflow.	Integer with sign

10.4.4 "Input values" submenu

The **Input values** submenu guides you systematically to the individual input values.

Navigation

"Diagnostics" menu → Measured values → Input values

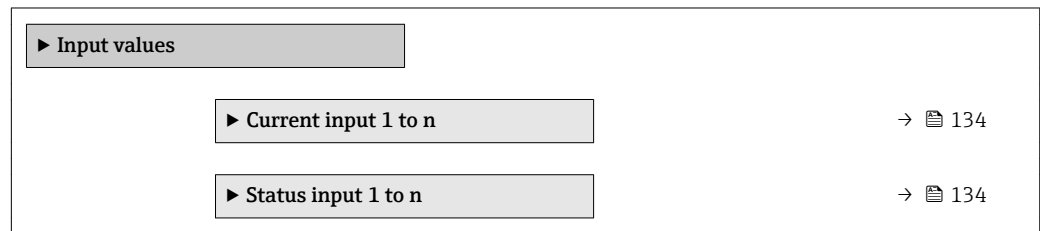

Input values of current input

The **Current input 1 to n** submenu contains all the parameters needed to display the current measured values for every current input.

Navigation

"Diagnostics" menu → Measured values → Input values → Current input 1 to n

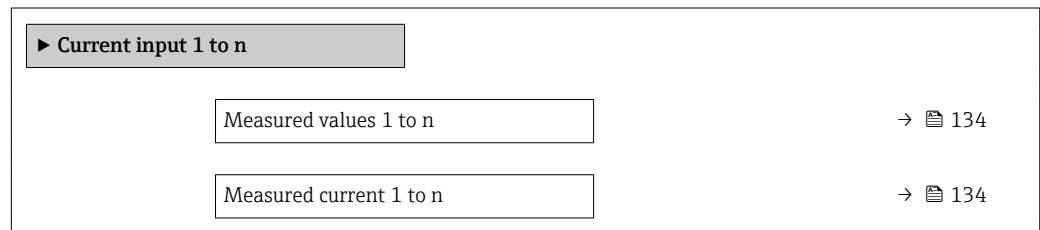

Parameter overview with brief description

Parameter	Description	User interface
Measured values 1 to n	Displays the current input value.	Signed floating-point number
Measured current 1 to n	Displays the current value of the current input.	0 to 22.5 mA

Input values of status input

The **Status input 1 to n** submenu contains all the parameters needed to display the current measured values for every status input.

Navigation

"Diagnostics" menu → Measured values → Input values → Status input 1 to n

▶ Status input 1 to n

Value status input

→ 135

Parameter overview with brief description

Parameter	Description	User interface
Value status input	Shows the current input signal level.	<ul style="list-style-type: none"> ■ High ■ Low

10.4.5 Output values

The **Output values** submenu contains all the parameters needed to display the current measured values for every output.

Navigation

"Diagnostics" menu → Measured values → Output values

▶ Output values

▶ Current output 1 to n

→ 135

▶ Pulse/frequency/switch output 1 to n

→ 136

▶ Relay output 1 to n

→ 136

Output values of current output

The **Value current output** submenu contains all the parameters needed to display the current measured values for every current output.

Navigation

"Diagnostics" menu → Measured values → Output values → Value current output 1 to n

▶ Current output 1 to n

Output current 1 to n

→ 136

Measured current 1 to n

→ 136

Parameter overview with brief description

Parameter	Description	User interface
Output current 1	Displays the current value currently calculated for the current output.	3.59 to 22.5 mA
Measured current	Displays the current value currently measured for the current output.	0 to 30 mA

Output values for pulse/frequency/switch output

The **Pulse/frequency/switch output 1 to n** submenu contains all the parameters needed to display the current measured values for every pulse/frequency/switch output.

Navigation

"Diagnostics" menu → Measured values → Output values → Pulse/frequency/switch output 1 to n

▶ Pulse/frequency/switch output 1 to n		
Output frequency 1 to n		→ 136
Pulse output 1 to n		→ 136
Switch status 1 to n		→ 136

Parameter overview with brief description

Parameter	Prerequisite	Description	User interface
Output frequency 1 to n	In the Operating mode parameter, the Frequency option is selected.	Displays the value currently measured for the frequency output.	0.0 to 12 500.0 Hz
Pulse output 1 to n	The Pulse option is selected in the Operating mode parameter parameter.	Displays the pulse frequency currently output.	Positive floating-point number
Switch status 1 to n	The Switch option is selected in the Operating mode parameter.	Displays the current switch output status.	<ul style="list-style-type: none"> ■ Open ■ Closed

Output values for relay output

The **Relay output 1 to n** submenu contains all the parameters needed to display the current measured values for every relay output.

Navigation

"Diagnostics" menu → Measured values → Output values → Relay output 1 to n



▶ Relay output 1 to n		
Switch status		→ 137
Switch cycles		→ 137
Max. switch cycles number		→ 137

Parameter overview with brief description

Parameter	Description	User interface
Switch status	Shows the current relay switch status.	<ul style="list-style-type: none"> ■ Open ■ Closed
Switch cycles	Shows number of all performed switch cycles.	Positive integer
Max. switch cycles number	Shows the maximal number of guaranteed switch cycles.	Positive integer

10.5 Adapting the measuring device to the process conditions

The following are available for this purpose:

- Basic settings using the **Setup** menu (→  80)
- Advanced settings using the **Advanced setup** submenu (→  107)



10.6 Performing a totalizer reset

The totalizers are reset in the **Operation** submenu:





- Control Totalizer
- Reset all totalizers

Navigation

"Operation" menu → Totalizer handling

▶ Totalizer handling	
Control Totalizer 1 to n	→  137
Preset value 1 to n	→  137
Reset all totalizers	→  137

Parameter overview with brief description

Parameter	Prerequisite	Description	Selection / User entry	Factory setting
Control Totalizer 1 to n	A process variable is selected in the Assign process variable parameter (→  108) of the Totalizer 1 to n submenu.	Control totalizer value.	<ul style="list-style-type: none"> ■ Totalize ■ Reset + hold ■ Preset + hold ■ Reset + totalize ■ Preset + totalize ■ Hold 	Totalize
Preset value 1 to n	A process variable is selected in the Assign process variable parameter (→  108) of the Totalizer 1 to n submenu.	Specify start value for totalizer. <i>Dependency</i>  The unit of the selected process variable is specified for the totalizer in the Unit totalizer parameter (→  108).	Signed floating-point number	0 kg
Reset all totalizers	–	Reset all totalizers to 0 and start.	<ul style="list-style-type: none"> ■ Cancel ■ Reset + totalize 	Cancel

10.6.1 Function scope of the "Control Totalizer" parameter



Options	Description
Totalize	The totalizer is started or continues running.
Reset + hold	The totaling process is stopped and the totalizer is reset to 0.
Preset + hold	The totaling process is stopped and the totalizer is set to its defined start value from the Preset value parameter.
Reset + totalize	The totalizer is reset to 0 and the totaling process is restarted.
Preset + totalize	The totalizer is set to the defined start value from the Preset value parameter and the totaling process is restarted.
Hold	Totalizing is stopped.

10.6.2 Function scope of the "Reset all totalizers" parameter

Options	Description
Cancel	No action is executed and the user exits the parameter.
Reset + totalize	Resets all totalizers to 0 and restarts the totaling process. This deletes all the flow values previously totalized.

10.7 Showing data logging

The **Extended HistoROM** application package must be enabled in the device (order option) for the **Data logging** submenu to appear. This contains all the parameters for the measured value history.

-  Data logging is also available via:
 - Plant Asset Management Tool FieldCare →  71.
 - Web browser

Function range

- A total of 1000 measured values can be stored
- 4 logging channels
- Adjustable logging interval for data logging
- Displays the measured value trend for each logging channel in the form of a chart

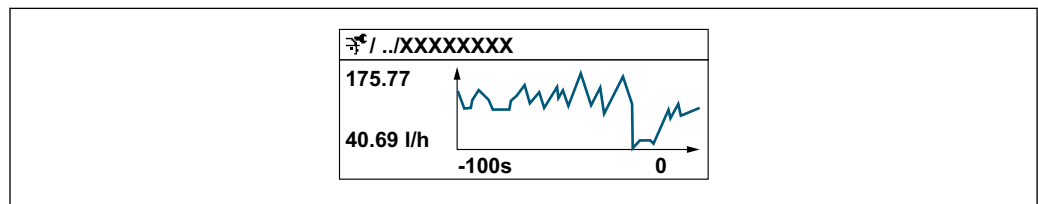

A0034352

- x-axis: depending on the number of channels selected displays 250 to 1000 measured values of a process variable.
- y-axis: displays the approximate measured value span and constantly adapts this to the ongoing measurement.







-  If the length of the logging interval or the assignment of the process variables to the channels is changed, the content of the data logging is deleted.

Navigation

"Diagnostics" menu → Data logging

▶ Data logging	
Assign channel 1	→ 140
Assign channel 2	→ 140
Assign channel 3	→ 140
Assign channel 4	→ 140
Logging interval	→ 140
Clear logging data	→ 140
Data logging	→ 140
Logging delay	→ 140
Data logging control	→ 141
Data logging status	→ 141
Entire logging duration	→ 141
▶ Display channel 1	
▶ Display channel 2	
▶ Display channel 3	
▶ Display channel 4	

Parameter overview with brief description

Parameter	Prerequisite	Description	Selection / User entry / User interface	Factory setting
Assign channel 1	The Extended HistorOM application package is available.	Assign process variable to logging channel.	<ul style="list-style-type: none"> ▪ Off ▪ Temperature ▪ Mass flow ▪ Corrected volume flow ▪ FAD volume flow * ▪ Volume flow ▪ Energy flow ▪ Heat flow * ▪ Density ▪ Flow velocity ▪ Pressure ▪ 2nd temperature delta heat * ▪ Electronic temperature ▪ Current output 1 * ▪ Current output 2 * ▪ Current output 3 * ▪ Current output 4 * 	Off
Assign channel 2	The Extended HistorOM application package is available.  The software options currently enabled are displayed in the Software option overview parameter.	Assign process variable to logging channel.	Picklist, see Assign channel 1 parameter (→  140)	Off
Assign channel 3	The Extended HistorOM application package is available.  The software options currently enabled are displayed in the Software option overview parameter.	Assign process variable to logging channel.	Picklist, see Assign channel 1 parameter (→  140)	Off
Assign channel 4	The Extended HistorOM application package is available.  The software options currently enabled are displayed in the Software option overview parameter.	Assign process variable to logging channel.	Picklist, see Assign channel 1 parameter (→  140)	Off
Logging interval	The Extended HistorOM application package is available.	Define the logging interval for data logging. This value defines the time interval between the individual data points in the memory.	0.1 to 3 600.0 s	1.0 s
Clear logging data	The Extended HistorOM application package is available.	Clear the entire logging data.	<ul style="list-style-type: none"> ▪ Cancel ▪ Clear data 	Cancel
Data logging	–	Select the data logging method.	<ul style="list-style-type: none"> ▪ Overwriting ▪ Not overwriting 	Overwriting
Logging delay	In the Data logging parameter, the Not overwriting option is selected.	Enter the time delay for measured value logging.	0 to 999 h	0 h

Parameter	Prerequisite	Description	Selection / User entry / User interface	Factory setting
Data logging control	In the Data logging parameter, the Not overwriting option is selected.	Start and stop measured value logging.	<ul style="list-style-type: none"> ■ None ■ Delete + start ■ Stop 	None
Data logging status	In the Data logging parameter, the Not overwriting option is selected.	Displays the measured value logging status.	<ul style="list-style-type: none"> ■ Done ■ Delay active ■ Active ■ Stopped 	Done
Entire logging duration	In the Data logging parameter, the Not overwriting option is selected.	Displays the total logging duration.	Positive floating-point number	0 s

* Visibility depends on order options or device settings

11 Diagnostics and troubleshooting

11.1 General troubleshooting

For local display

Error	Possible causes	Solution
Local display dark and no output signals	Supply voltage does not match the value indicated on the nameplate.	Apply the correct supply voltage → 41.
Local display dark and no output signals	The polarity of the supply voltage is wrong.	Correct the polarity.
Local display dark and no output signals	No contact between connecting cables and terminals.	Check the connection of the cables and correct if necessary.
Local display dark and no output signals	Terminals are not plugged into the I/O electronics module correctly. Terminals are not plugged into the main electronics module correctly.	Check terminals.
Local display dark and no output signals	I/O electronics module is defective. Main electronics module is defective.	Order spare part → 165.
Local display dark and no output signals	The connector between the main electronics module and display module is not plugged in correctly.	Check the connection and correct if necessary.
Local display dark and no output signals	The connecting cable is not plugged in correctly.	1. Check the connection of the electrode cable and correct if necessary. 2. Check the connection of the coil current cable and correct if necessary.
Local display is dark, but signal output is within the valid range	Display is set too bright or too dark.	<ul style="list-style-type: none"> ▪ Set the display brighter by simultaneously pressing $\square + \square$. ▪ Set the display darker by simultaneously pressing $\square + \square$.
Local display is dark, but signal output is within the valid range	The cable of the display module is not plugged in correctly.	Insert the plug correctly into the main electronics module and display module.
Local display is dark, but signal output is within the valid range	Display module is defective.	Order spare part → 165.
Backlighting of local display is red	Diagnostic event with "Alarm" diagnostic behavior has occurred.	Take remedial measures → 153
Text on local display appears in a foreign language and cannot be understood.	Incorrect operating language is configured.	1. Press $\square + \square$ for 2 s ("home position"). 2. Press \square . 3. Set the desired language in the Display language parameter (→ 112).
Message on local display: "Communication Error" "Check Electronics"	Communication between the display module and the electronics is interrupted.	<ul style="list-style-type: none"> ▪ Check the cable and the connector between the main electronics module and display module. ▪ Order spare part → 165.

For output signals

Error	Possible causes	Solution
Signal output outside the valid range	Main electronics module is defective.	Order spare part → 165.
Device shows correct value on local display, but signal output is incorrect, though in the valid range.	Configuration error	Check and correct the parameter configuration.
Device measures incorrectly.	Configuration error or device is operated outside the application.	1. Check and correct parameter configuration. 2. Observe limit values specified in the "Technical Data".

For access

Error	Possible causes	Solution
No write access to parameters	Hardware write protection enabled	Set the write protection switch on main electronics module to the OFF position → 129.
No write access to parameters	Current user role has limited access authorization	1. Check user role → 61. 2. Enter correct customer-specific access code → 61.
No connection via Modbus RS485	Modbus RS485 bus cable connected incorrectly	Check terminal assignment → 36.
No connection via Modbus RS485	Modbus RS485 cable incorrectly terminated	Check terminating resistor → 46.
No connection via Modbus RS485	Incorrect settings for the communication interface	Check the Modbus RS485 configuration .
Not connecting to Web server	Web server disabled	Using the "FieldCare" or "DeviceCare" operating tool, check whether the Web server of the measuring device is enabled, and enable it if necessary → 68.
	Incorrect setting for the Ethernet interface of the computer	1. Check the properties of the Internet protocol (TCP/IP) → 64 → 64. 2. Check the network settings with the IT manager.
Not connecting to Web server	Incorrect IP address	Check the IP address: 192.168.1.212 → 64 → 64
Not connecting to Web server	Incorrect WLAN access data	<ul style="list-style-type: none"> ▪ Check WLAN network status. ▪ Log on to the device again using WLAN access data. ▪ Verify that WLAN is enabled on the measuring device and operating device → 64.
	WLAN communication disabled	–
Not connecting to Web server, FieldCare or DeviceCare	No WLAN network available	<ul style="list-style-type: none"> ▪ Check if WLAN reception is present: LED on display module is lit blue ▪ Check if WLAN connection is enabled: LED on display module flashes blue ▪ Switch on instrument function.
Network connection not present or unstable	WLAN network is weak.	<ul style="list-style-type: none"> ▪ Operating device is outside of reception range: Check network status on operating device. ▪ To improve network performance, use an external WLAN antenna.

Error	Possible causes	Solution
	Parallel WLAN and Ethernet communication	<ul style="list-style-type: none"> ▪ Check network settings. ▪ Temporarily enable only the WLAN as an interface.
Web browser frozen and operation no longer possible	Data transfer active	Wait until data transfer or current action is finished.
	Connection lost	<ol style="list-style-type: none"> 1. Check cable connection and power supply. 2. Refresh the Web browser and restart if necessary.
Content of Web browser incomplete or difficult to read	Not using optimum version of Web server.	<ol style="list-style-type: none"> 1. Use the correct Web browser version → 63. 2. Clear the Web browser cache and restart the Web browser.
	Unsuitable view settings.	Change the font size/display ratio of the Web browser.
No or incomplete display of contents in the Web browser	<ul style="list-style-type: none"> ▪ JavaScript not enabled ▪ JavaScript cannot be enabled 	<ol style="list-style-type: none"> 1. Enable JavaScript. 2. Enter http://XXX.XXX.X.XXX/basic.html as the IP address.
Operation with FieldCare or DeviceCare via CDI-RJ45 service interface (port 8000)	Firewall of computer or network is preventing communication	Depending on the settings of the firewall used on the computer or in the network, the firewall must be adapted or disabled to allow FieldCare/DeviceCare access.
Flashing of firmware with FieldCare or DeviceCare via CDI-RJ45 service interface (via port 8000 or TFTP ports)	Firewall of computer or network is preventing communication	Depending on the settings of the firewall used on the computer or in the network, the firewall must be adapted or disabled to allow FieldCare/DeviceCare access.

11.2 Diagnostic information via light emitting diodes

11.2.1 Transmitter

Proline 500 – digital

Different LEDs in the transmitter provide information on the device status.

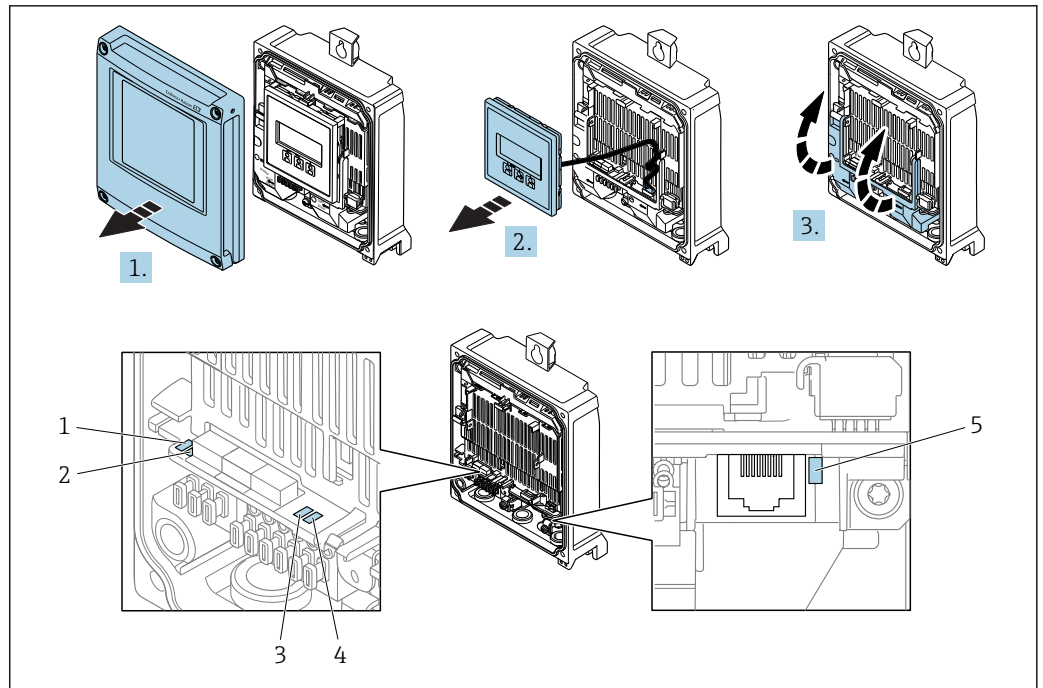

A0029689

- 1 Supply voltage
- 2 Device status
- 3 Not used
- 4 Communication
- 5 Service interface (CDI) active

1. Open the housing cover.
2. Remove the display module.
3. Fold open the terminal cover.

LED	Color	Meaning
1 Supply voltage	Off	Supply voltage is off or too low.
	Green	Supply voltage is ok.
2 Device status (normal operation)	Off	Firmware error
	Green	Device status is ok.
	Flashing green	Device is not configured.
	Flashing red	A diagnostic event with "Warning" diagnostic behavior has occurred.
	Red	A diagnostic event with "Alarm" diagnostic behavior has occurred.
2 Device status (during start-up)	Flashes red slowly	If > 30 seconds: problem with the boot loader.
	Flashes red quickly	If > 30 seconds: compatibility problem when reading the firmware.
3 Not used	-	-
4 Communication	Off	Communication not active.
	White	Communication active.
5 Service interface (CDI)	Off	Not connected or no connection established.
	Yellow	Connected and connection established.
	Flashing yellow	Service interface active.

11.2.2 Sensor connection housing

Proline 500 – digital

Various light emitting diodes (LED) on the ISEM electronics (Intelligent Sensor Electronic Module) in the sensor connection housing provide information on the device status.

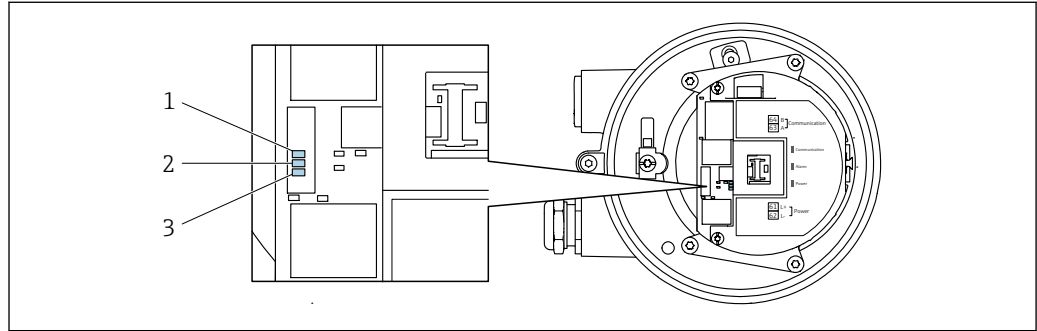

A0029699

- 1 *Communication*
- 2 *Device status*
- 3 *Supply voltage*

LED	Color	Meaning
1 Communication	White	Communication active.
2 Device status (normal operation)	Red	Problem
	Flashing red	Warning
2 Device status (during start-up)	Flashes red slowly	If > 30 seconds: problem with the boot loader.
	Flashes red quickly	If > 30 seconds: compatibility problem when reading the firmware.
3 Supply voltage	Green	Supply voltage is ok.
	Off	Supply voltage is off or too low.

11.3 Diagnostic information on local display

11.3.1 Diagnostic message

Faults detected by the self-monitoring system of the measuring device are displayed as a diagnostic message in alternation with the operational display.

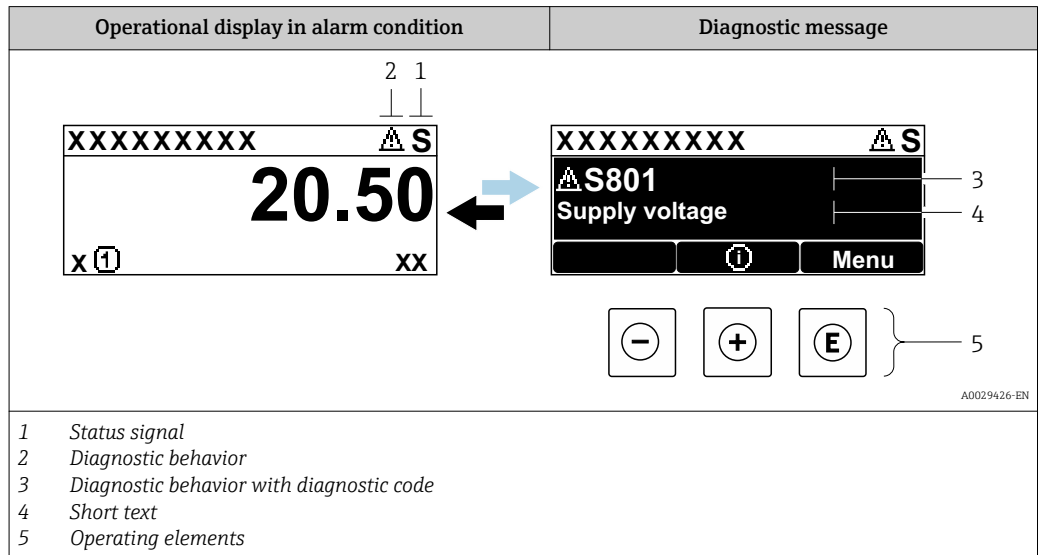

If two or more diagnostic events are pending simultaneously, only the message of the diagnostic event with the highest priority is shown.

- i** Other diagnostic events that have occurred can be displayed in the **Diagnostics** menu:
 - Via parameter → 156
 - Via submenus → 157



Status signals

The status signals provide information on the state and reliability of the device by categorizing the cause of the diagnostic information (diagnostic event).

- i** The status signals are categorized according to VDI/VDE 2650 and NAMUR Recommendation NE 107: F = Failure, C = Function Check, S = Out of Specification, M = Maintenance Required

Symbol	Meaning
F	Failure A device error has occurred. The measured value is no longer valid.
C	Function check The device is in service mode (e.g. during a simulation).
S	Out of specification The device is operated: Outside its technical specification limits (e.g. outside the process temperature range)
M	Maintenance required Maintenance is required. The measured value remains valid.

Diagnostic behavior



Symbol	Meaning
	Alarm <ul style="list-style-type: none"> ▪ Measurement is interrupted. ▪ Signal outputs and totalizers assume the defined alarm condition. ▪ A diagnostic message is generated.
	Warning Measurement is resumed. The signal outputs and totalizers are not affected. A diagnostic message is generated.

Diagnostic information

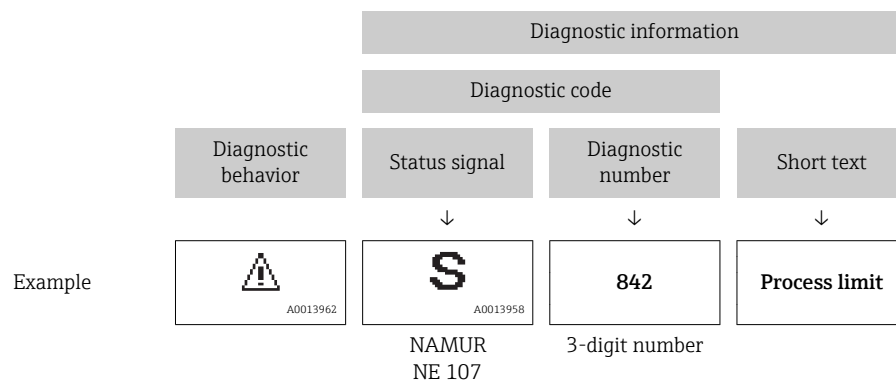
The fault can be identified using the diagnostic information. The short text helps you by providing information about the fault. In addition, the corresponding symbol for the diagnostic behavior is displayed in front of the diagnostic information on the local display.



Operating elements

Key	Meaning
	Plus key <i>In a menu, submenu</i> Opens the message about remedy information.
	Enter key <i>In a menu, submenu</i> Opens the operating menu.

11.3.2 Calling up remedial measures

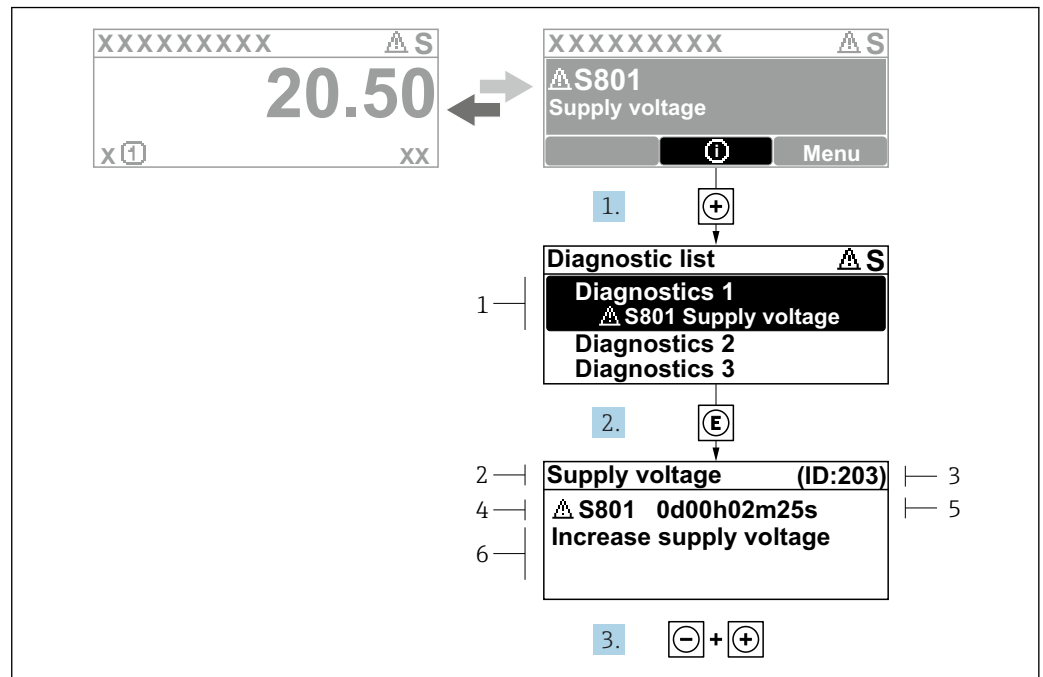

36 Message about remedial measures

- 1 Diagnostic information
- 2 Short text
- 3 Service ID
- 4 Diagnostic behavior with diagnostic code
- 5 Operation time of occurrence
- 6 Remedial measures

1. The user is in the diagnostic message.
Press \oplus ($\textcircled{1}$ symbol).
↳ The **Diagnostic list** submenu opens.
2. Select the desired diagnostic event with \oplus or \ominus and press E .
↳ The message about the remedial measures opens.
3. Press $\ominus + \oplus$ simultaneously.
↳ The message about the remedial measures closes.

The user is in the **Diagnostics** menu at an entry for a diagnostics event, e.g. in the **Diagnostic list** submenu or **Previous diagnostics** parameter.

1. Press E .
↳ The message for the remedial measures for the selected diagnostic event opens.
2. Press $\ominus + \oplus$ simultaneously.
↳ The message for the remedial measures closes.

11.4 Diagnostic information in the Web browser



11.4.1 Diagnostic options

Any faults detected by the measuring device are displayed in the Web browser on the home page once the user has logged on.

The screenshot displays the 'Instrument health status' page. At the top, there is a header with fields for 'Device name', 'Device tag', 'Status signal', 'Volume flow', 'Mass flow', and 'Conductivity'. The 'Status signal' field shows a warning icon and the text 'Out of specificati...'. Below this is a navigation bar with options: 'Measured values', 'Menu', 'Instrument health status', 'Data management', 'Network', and 'Logging'. The main content area is titled 'Instrument health status' and shows a warning icon followed by 'Out of specification (S)'. Below this, there is a diagnostic event entry: 'S441 Current output 1 (Warning) 13d01h35m59s'. To the right of this entry is a red box containing the text '1. Check process 2. Check current output settings (Service ID: 153)'. A 'Diagnostics' button is visible below the event entry. Three numbered callouts (1, 2, 3) point to the status signal, the diagnostic event, and the remedy information respectively.





- 1 Status area with status signal
- 2 Diagnostic information
- 3 Remedy information with Service ID

 In addition, diagnostic events which have occurred can be shown in the **Diagnostics** menu:

- Via parameter →  156
- Via submenu →  157

Status signals

The status signals provide information on the state and reliability of the device by categorizing the cause of the diagnostic information (diagnostic event).

Symbol	Meaning
	Failure A device error has occurred. The measured value is no longer valid.
	Function check The device is in service mode (e.g. during a simulation).
	Out of specification The device is operated: Outside its technical specification limits (e.g. outside the process temperature range)
	Maintenance required Maintenance is required. The measured value is still valid.

 The status signals are categorized in accordance with VDI/VDE 2650 and NAMUR Recommendation NE 107.

11.4.2 Calling up remedy information

Remedy information is provided for every diagnostic event to ensure that problems can be rectified quickly. These measures are displayed in red along with the diagnostic event and the related diagnostic information.

11.5 Diagnostic information in FieldCare or DeviceCare

11.5.1 Diagnostic options

Any faults detected by the measuring device are displayed on the home page of the operating tool once the connection has been established.

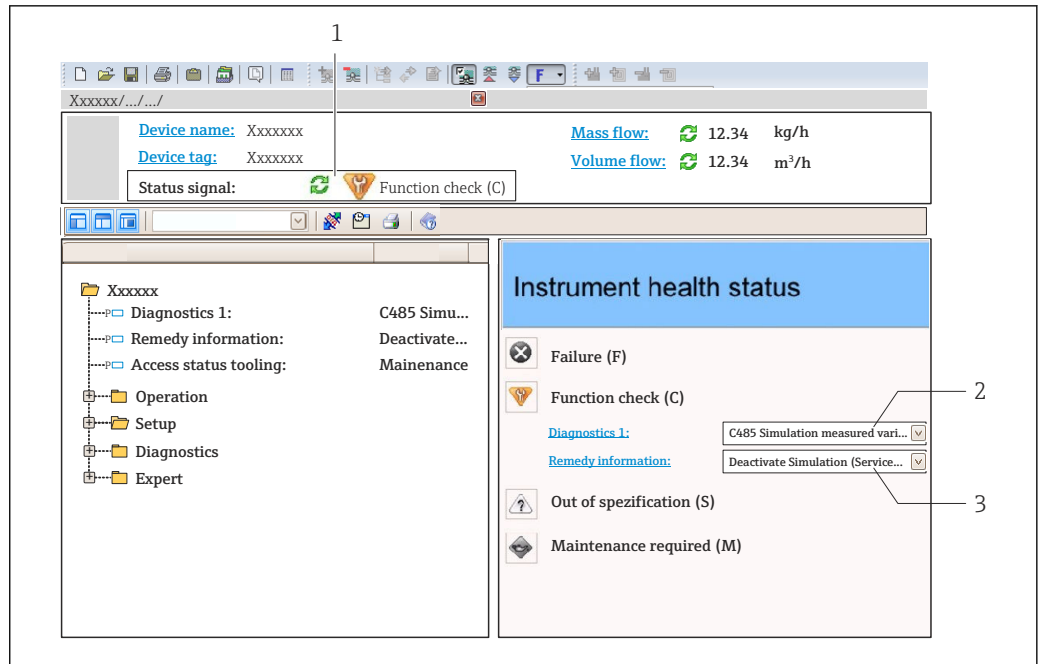

- 1 Status area with status signal → 147
- 2 Diagnostic information → 148
- 3 Remedy information with Service ID

i In addition, diagnostic events which have occurred can be shown in the **Diagnostics** menu:

- Via parameter → 156
- Via submenu → 157

Diagnostic information

The fault can be identified using the diagnostic information. The short text helps you by providing information about the fault. In addition, the corresponding symbol for the diagnostic behavior is displayed in front of the diagnostic information on the local display.

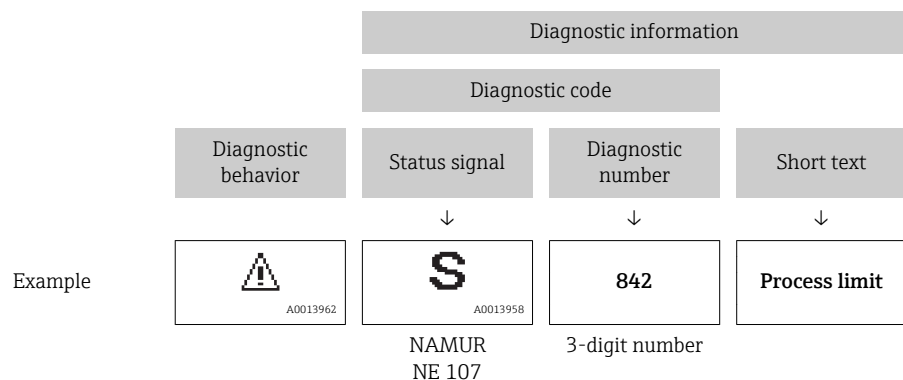

11.5.2 Calling up remedy information

Remedy information is provided for every diagnostic event to ensure that problems can be rectified quickly:

- On the home page
Remedy information is displayed in a separate field below the diagnostics information.
- In the **Diagnostics** menu
Remedy information can be called up in the working area of the user interface.

The user is in the **Diagnostics** menu.



1. Call up the desired parameter.
2. On the right in the working area, mouse over the parameter.
 - ↳ A tool tip with remedy information for the diagnostic event appears.

11.6 Diagnostic information via communication interface

11.6.1 Reading out diagnostic information

Diagnostic information can be read out via Modbus RS485 register addresses.

- Via register address **6821** (data type = string): diagnosis code, e.g. F270
- Via register address **6859** (data type = integer): diagnosis number, e.g. 270

 For an overview of diagnostic events with diagnosis number and diagnosis code
→  153



11.6.2 Configuring error response mode

The error response mode for Modbus RS485 communication can be configured in the **Communication** submenu using 2 parameters.

Navigation path

Setup → Communication

Parameter overview with brief description

Parameters	Description	Selection	Factory setting
Failure mode	Select measured value output behavior when a diagnostic message occurs via Modbus communication.  This effect of this parameter depends on the option selected in the Assign diagnostic behavior parameter.	<ul style="list-style-type: none"> ■ NaN value ■ Last valid value  NaN ≙ not a number	NaN value

11.7 Adapting the diagnostic information

11.7.1 Adapting the diagnostic behavior

Each item of diagnostic information is assigned a specific diagnostic behavior at the factory. The user can change this assignment for specific diagnostic information in the **Diagnostic behavior** submenu.

Expert → System → Diagnostic handling → Diagnostic behavior



You can assign the following options to the diagnostic number as the diagnostic behavior:

Options	Description
Alarm	The device stops measurement. The measured value output via Modbus RS485 and the totalizers assume the defined alarm condition. A diagnostic message is generated. The background lighting changes to red.
Warning	The device continues to measure. The measured value output via Modbus RS485 and the totalizers are not affected. A diagnostic message is generated.

Options	Description
Logbook entry only	The device continues to measure. The diagnostic message is displayed only in the Event logbook submenu (Event list submenu) and is not displayed in alternation with the operational display.
Off	The diagnostic event is ignored, and no diagnostic message is generated or entered.

11.8 Overview of diagnostic information

 The amount of diagnostic information and the number of measured variables affected increase if the measuring device has one or more application packages.

 In the case of some items of diagnostic information, the diagnostic behavior can be changed. Change the diagnostic information →  152

Diagnostic number	Short text	Remedy instructions	Status signal [from the factory]	Diagnostic behavior [from the factory]
Diagnostic of sensor				
004	Sensor error	Change sensor	F	Alarm
082	Data storage	1. Check module connections 2. Change electronic modules	F	Alarm
083	Memory content	1. Restart device 2. Restore HistoROM S-DAT backup ('Device reset' parameter) 3. Replace HistoROM S-DAT	F	Alarm
144	Sensor drift	1. Check sensor 2. Replace sensor	F	Alarm ¹⁾
Diagnostic of electronic				
201	Device failure	Restart device	F	Alarm
242	Software incompatible	1. Check software 2. Flash or change main electronics module	F	Alarm
252	Modules incompatible	1. Check electronic modules 2. Check if correct modules are available (e.g. NEx, Ex) 3. Replace electronic modules	F	Alarm
252	Modules incompatible	1. Check if correct electronic modul is plugged 2. Replace electronic module	F	Alarm
262	Sensor electronic connection faulty	1. Check or replace connection cable between sensor electronic module (ISEM) and main electronics 2. Check or replace ISEM or main electronics	F	Alarm
270	Main electronic failure	Change main electronic module	F	Alarm
271	Main electronic failure	1. Restart device 2. Change main electronic module	F	Alarm
272	Main electronic failure	Restart device	F	Alarm
273	Main electronic failure	Change electronic	F	Alarm
275	I/O module 1 to n defective	Change I/O module	F	Alarm
276	I/O module 1 to n faulty	1. Restart device 2. Change I/O module	F	Alarm
281	Electronic initialization	Firmware update active, please wait!	F	Alarm

Diagnostic number	Short text	Remedy instructions	Status signal [from the factory]	Diagnostic behavior [from the factory]
283	Memory content	Reset device	F	Alarm
283	Memory content	Restart device	F	Alarm
302	Device verification in progress	Device verification active, please wait.	C	Warning
303	I/O 1 to n configuration changed	1. Apply I/O module configuration (parameter 'Apply I/O configuration') 2. Afterwards reload device description and check wiring	M	Warning
311	Electronic failure	1. Do not reset device 2. Contact service	M	Warning
332	Writing in HistoROM backup failed	Replace user interface board Ex d/XP: replace transmitter	F	Alarm
361	I/O module 1 to n faulty	1. Restart device 2. Check electronic modules 3. Change I/O Modul or main electronics	F	Alarm
372	Sensor electronic (ISEM) faulty	1. Restart device 2. Check if failure recurs 3. Replace sensor electronic module (ISEM)	F	Alarm
373	Sensor electronic (ISEM) faulty	Transfer data or reset device	F	Alarm
375	I/O- 1 to n communication failed	1. Restart device 2. Check if failure recurs 3. Replace module rack inclusive electronic modules	F	Alarm
378	Supply voltage ISEM faulty	Check supply voltage to the ISEM	F	Alarm
382	Data storage	1. Insert T-DAT 2. Replace T-DAT	F	Alarm
383	Memory content	1. Restart device 2. Delete T-DAT via 'Reset device' parameter 3. Replace T-DAT	F	Alarm
387	HistoROM data faulty	Contact service organization	F	Alarm
Diagnostic of configuration				
330	Flash file invalid	1. Update firmware of device 2. Restart device	M	Warning
331	Firmware update failed	1. Update firmware of device 2. Restart device	F	Warning
410	Data transfer	1. Check connection 2. Retry data transfer	F	Alarm
412	Processing download	Download active, please wait	C	Warning
431	Trim 1 to n	Carry out trim	C	Warning
437	Configuration incompatible	Restart device	F	Alarm
438	Dataset	1. Check data set file 2. Check device configuration 3. Up- and download new configuration	M	Warning

Diagnostic number	Short text	Remedy instructions	Status signal [from the factory]	Diagnostic behavior [from the factory]
441	Current output 1 to n	1. Check process 2. Check current output settings	S	Warning ¹⁾
442	Frequency output 1 to n	1. Check process 2. Check frequency output settings	S	Warning ¹⁾
442	Frequency output 1 to n		S	Warning
443	Pulse output 1 to n	1. Check process 2. Check pulse output settings	S	Warning ¹⁾
444	Current input 1 to n	1. Check process 2. Check current input settings	S	Warning ¹⁾
453	Flow override	Deactivate flow override	C	Warning
484	Failure mode simulation	Deactivate simulation	C	Alarm
485	Measured variable simulation	Deactivate simulation	C	Warning
486	Current input 1 to n simulation	Deactivate simulation	C	Warning
491	Current output 1 to n simulation	Deactivate simulation	C	Warning
492	Simulation frequency output 1 to n	Deactivate simulation frequency output	C	Warning
493	Simulation pulse output 1 to n	Deactivate simulation pulse output	C	Warning
494	Switch output simulation 1 to n	Deactivate simulation switch output	C	Warning
495	Diagnostic event simulation	Deactivate simulation	C	Warning
496	Status input simulation	Deactivate simulation status input	C	Warning
520	I/O 1 to n hardware configuration invalid	1. Check I/O hardware configuration 2. Replace wrong I/O module 3. Plug the module of double pulse output on correct slot	F	Alarm
537	Configuration	1. Check IP addresses in network 2. Change IP address	F	Warning
539	Flow computer configuration incorrect	1. Check input value (pressure, temperature) 2. Check allowed values of the medium properties	S	Alarm
594	Relay output simulation	Deactivate simulation switch output	C	Warning
Diagnostic of process				
803	Current loop	1. Check wiring 2. Change I/O module	F	Alarm
832	Electronic temperature too high	Reduce ambient temperature	S	Warning ¹⁾
833	Electronic temperature too low	Increase ambient temperature	S	Warning ¹⁾
834	Process temperature too high	Reduce process temperature	S	Warning ¹⁾
835	Process temperature too low	Increase process temperature	S	Warning ¹⁾





Diagnostic number	Short text	Remedy instructions	Status signal [from the factory]	Diagnostic behavior [from the factory]
842	Process limit	Low flow cut off active! 1. Check low flow cut off configuration	S	Warning ¹⁾
882	Input signal	1. Check input configuration 2. Check external device or process conditions	F	Alarm
941	Flow velocity too high	1. Check process cond. 2. Increase system pressure	S	Alarm
961	Delta temperature	Check flow rate	S	Alarm
976	Mass flow out of calibrated range	1. Check process cond. 2. Increase system pressure	S	Warning ¹⁾
977	Reverse flow detected	Check flow direction	S	Warning ¹⁾
979	Unstable process conditions	1. Check process cond. 2. Increase system pressure	S	Warning ¹⁾



1) Diagnostic behavior can be changed.

11.9 Pending diagnostic events

The **Diagnostics** menu allows the user to view the current diagnostic event and the previous diagnostic event separately.





 To call up the measures to rectify a diagnostic event:

- Via local display →  149
- Via Web browser →  150
- Via "FieldCare" operating tool →  151
- Via "DeviceCare" operating tool →  151

 Other pending diagnostic events can be displayed in the **Diagnostic list** submenu →  157

Navigation

"Diagnostics" menu

Diagnostics	
Actual diagnostics	→  157
Previous diagnostics	→  157
Operating time from restart	→  157
Operating time	→  157

Parameter overview with brief description

Parameter	Prerequisite	Description	User interface
Actual diagnostics	A diagnostic event has occurred.	Shows the current occurred diagnostic event along with its diagnostic information.  If two or more messages occur simultaneously, the message with the highest priority is shown on the display.	Symbol for diagnostic behavior, diagnostic code and short message.
Previous diagnostics	Two diagnostic events have already occurred.	Shows the diagnostic event that occurred prior to the current diagnostic event along with its diagnostic information.	Symbol for diagnostic behavior, diagnostic code and short message.
Operating time from restart	–	Shows the time the device has been in operation since the last device restart.	Days (d), hours (h), minutes (m) and seconds (s)
Operating time	–	Indicates how long the device has been in operation.	Days (d), hours (h), minutes (m) and seconds (s)

11.10 Diagnostic list

Up to 5 currently pending diagnostic events can be displayed in the **Diagnostic list** submenu along with the associated diagnostic information. If more than 5 diagnostic events are pending, the events with the highest priority are shown on the display.

Navigation path



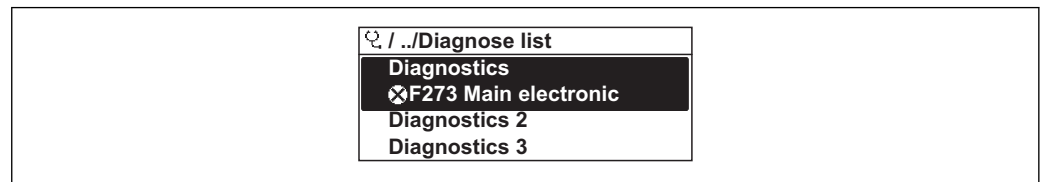

Diagnostics → Diagnostic list



A0014006-EN

 37 Taking the example of the local display

 To call up the measures to rectify a diagnostic event:

- Via local display →  149
- Via Web browser →  150
- Via "FieldCare" operating tool →  151
- Via "DeviceCare" operating tool →  151

11.11 Event logbook

11.11.1 Reading out the event logbook

A chronological overview of the event messages that have occurred is provided in the **Events list** submenu.

Navigation path

Diagnostics menu → **Event logbook** submenu → Event list

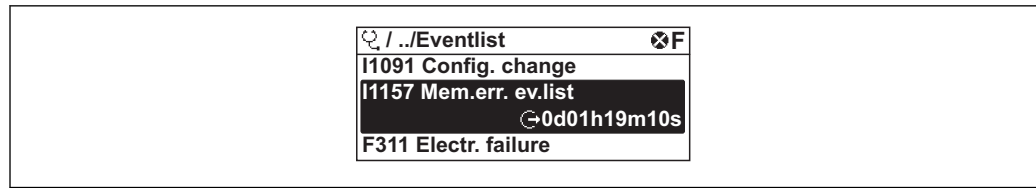

A0014008-EN

38 Taking the example of the local display

- A maximum of 20 event messages can be displayed in chronological order.
- If the **Extended HistoROM** application package (order option) is enabled in the device, the event list can contain up to 100 entries .

The event history includes entries for:

- Diagnostic events → 153
- Information events → 158

In addition to the operation time of its occurrence, each event is also assigned a symbol that indicates whether the event has occurred or is ended:

- Diagnostic event
 - : Occurrence of the event
 - : End of the event
- Information event
 - : Occurrence of the event

To call up the measures to rectify a diagnostic event:

- Via local display → 149
- Via Web browser → 150
- Via "FieldCare" operating tool → 151
- Via "DeviceCare" operating tool → 151

For filtering the displayed event messages → 158

11.11.2 Filtering the event logbook

Using the **Filter options** parameter you can define which category of event message is displayed in the **Events list** submenu.

Navigation path

Diagnostics → Event logbook → Filter options

Filter categories

- All
- Failure (F)
- Function check (C)
- Out of specification (S)
- Maintenance required (M)
- Information (I)

11.11.3 Overview of information events

Unlike a diagnostic event, an information event is displayed in the event logbook only and not in the diagnostic list.

Info number	Info name
I1000	----- (Device ok)
I1079	Sensor changed
I1089	Power on
I1090	Configuration reset
I1091	Configuration changed

Info number	Info name
I1092	HistoROM backup deleted
I1137	Electronic changed
I1151	History reset
I1155	Reset electronic temperature
I1156	Memory error trend
I1157	Memory error event list
I1221	Zero point adjust failure
I1222	Zero point adjustment ok
I1256	Display: access status changed
I1264	Safety sequence aborted
I1278	I/O module restarted
I1335	Firmware changed
I1361	Web server: login failed
I1397	Fieldbus: access status changed
I1398	CDI: access status changed
I1444	Device verification passed
I1445	Device verification failed
I1457	Measurement error verification failed
I1459	I/O module verification failed
I1461	Sensor verification failed
I1462	Sensor electronic module verific. failed
I1512	Download started
I1513	Download finished
I1514	Upload started
I1515	Upload finished
I1554	Safety sequence started
I1555	Safety sequence confirmed
I1556	Safety mode off
I1618	I/O module 2 replaced
I1619	I/O module 3 replaced
I1621	I/O module 4 replaced
I1622	Calibration changed
I1624	Reset all totalizers
I1625	Write protection activated
I1626	Write protection deactivated
I1627	Web server: login successful
I1628	Display: login successful
I1629	CDI: login successful
I1631	Web server access changed
I1632	Display: login failed
I1633	CDI: login failed
I1634	Reset to factory settings
I1635	Reset to delivery settings

Info number	Info name
I1639	Max. switch cycles number reached
I1649	Hardware write protection activated
I1650	Hardware write protection deactivated
I1712	New flash file received
I1725	Sensor electronic module (ISEM) changed
I1726	Configuration backup failed

11.12 Resetting the measuring device

Using the **Device reset** parameter (→ ⓘ 117) it is possible to reset the entire device configuration or some of the configuration to a defined state.

11.12.1 Function scope of the "Device reset" parameter

Options	Description
Cancel	No action is executed and the user exits the parameter.
To delivery settings	Every parameter for which a customer-specific default setting was ordered is reset to this customer-specific value. All other parameters are reset to the factory setting.
Restart device	The restart resets every parameter whose data are in the volatile memory (RAM) to the factory setting (e.g. measured value data). The device configuration remains unchanged.
Restore S-DAT backup	Restore the data that are saved on the S-DAT. The data record is restored from the electronics memory to the S-DAT.  This option is displayed only in an alarm condition.

11.13 Device information

The **Device information** submenu contains all parameters that display different information for device identification.



Navigation

"Diagnostics" menu → Device information



► Device information	
Device tag	→ ⓘ 161
Serial number	→ ⓘ 161
Firmware version	→ ⓘ 161
Device name	→ ⓘ 161
Order code	→ ⓘ 161
Extended order code 1	→ ⓘ 161

Extended order code 2	→ ⓘ 161
Extended order code 3	→ ⓘ 161
ENP version	→ ⓘ 161

Parameter overview with brief description

Parameter	Description	User interface	Factory setting
Device tag	Shows name of measuring point.	Max. 32 characters, such as letters, numbers or special characters (e.g. @, %, /).	t-mass
Serial number	Shows the serial number of the measuring device.	Max. 11-digit character string comprising letters and numbers.	-
Firmware version	Shows the device firmware version installed.	Character string in the format xx.yy.zz	-
Device name	Shows the name of the transmitter.  The name can be found on the nameplate of the transmitter.		-
Order code	Shows the device order code.	Character string composed of letters, numbers and certain punctuation marks (e.g. /).	-
Extended order code 1	Shows the 1st part of the extended order code.	Character string	-
Extended order code 2	Shows the 2nd part of the extended order code.  The extended order code can also be found on the nameplate of the sensor and transmitter in the "Ext. ord. cd." field.	Character string	-
Extended order code 3	Shows the 3rd part of the extended order code.  The extended order code can also be found on the nameplate of the sensor and transmitter in the "Ext. ord. cd." field.	Character string	-
ENP version	Shows the version of the electronic nameplate (ENP).	Character string	2.02.00

11.14 Firmware history

-  It is possible to flash the firmware to the current version or the previous version using the service interface. For the compatibility of the firmware version, see the "Device history and compatibility" section → ⓘ 162
-  For the compatibility of the firmware version with the previous version, the installed device description files and operating tools, observe the information about the device in the "Manufacturer's information" document.
-  The manufacturer's information is available:
 - In the Download Area of the Endress+Hauser web site: www.endress.com → Downloads
 - Specify the following details:
 - Text search: Manufacturer's information
 - Media type: Documentation – Technical Documentation

11.15 Device history and compatibility

The device model is documented in the order code on the nameplate of the device (e.g. 8F3BXX-XXX...XXA1-XXXXXX).

12 Maintenance

12.1 Maintenance tasks

No special maintenance work is required.

12.1.1 Exterior cleaning

When cleaning the exterior of measuring devices, always use cleaning agents that do not attack the surface of the housing or the seals.

12.1.2 Sensing element cleaning

The sensing element can be removed for cleaning.

WARNING

Injury from sensing element being ejected!

- ▶ Ensure the system is unpressurized before commencing the cleaning work.

NOTICE

Damage to the sensing element!

- ▶ Make sure the sensing elements do not hit against anything.

NOTICE

Damage to the sealing surfaces!

- ▶ Make sure the sealing surfaces do not hit against anything.

NOTICE

The use of unsuitable cleaning equipment or cleaning liquids can damage the sensing element.

- ▶ Do not use pigs to clean the pipe.
- ▶ Use an oil-free cleaning agent that does not form a film to clean the sensor.

NOTICE

Overtightening the threaded joint can damage the sensing element!

- ▶ Apply a maximum torque of 120 Nm to tighten the threaded joint.

1. Ensure the system is unpressurized.
2. Release the threaded joint of the sensing element.
3. Carefully remove the sensing element from the sensor.
4. Gently clean the sensing elements using a soft brush.
5. Introduce the sensing element carefully into the sensor.
 - ↳ Make sure the notch in the sensor and the groove on the sensing element are aligned correctly.
6. Tighten the threaded joint of the sensing element by hand.
7. Tighten the threaded joint of the sensing element by $\frac{1}{8}$ turn using the tool.

-  Increase the pressure in the piping system and check for leaks once the desired pressure is reached.

Cleaning the sensing element

12.1.3 Recalibration

In the case of thermal measuring devices, the time between the calibration and the point when values begin to deviate depends on the contamination that the sensor surface is exposed to.

If the gas is impure (e.g. due to particles), regular sensor cleaning intervals are recommended. The intervals depend on the type, condition and extent of the contamination.

Determining the recalibration intervals:

- In the event of critical measurements and in order to determine the recalibration intervals, a calibration check should be performed once a year. The check should be performed twice a year if using in wet and impure gas.
The next recalibration can then be scheduled earlier or later depending on the results of these checks.
- A recalibration every three years is recommended for non-critical applications or for use in purified and dry gases.

12.2 Measuring and test equipment

Endress+Hauser offers a wide variety of measuring and test equipment, such as W@M or device tests.

 Your Endress+Hauser Sales Center can provide detailed information on the services.

List of some of the measuring and testing equipment: →  169

12.3 Endress+Hauser services

Endress+Hauser offers a wide variety of services for maintenance such as recalibration, maintenance service or device tests.

 Your Endress+Hauser Sales Center can provide detailed information on the services.

13 Repair

13.1 General notes

13.1.1 Repair and conversion concept

The Endress+Hauser repair and conversion concept provides for the following:

- The measuring devices have a modular design.
- Spare parts are grouped into logical kits with the associated Installation Instructions.
- Repairs are carried out by Endress+Hauser Service or by appropriately trained customers.
- Certified devices can only be converted to other certified devices by Endress+Hauser Service or at the factory.

13.1.2 Notes for repair and conversion



For repair and modification of a measuring device, observe the following notes:

- ▶ Use only original Endress+Hauser spare parts.
- ▶ Carry out the repair according to the Installation Instructions.
- ▶ Observe the applicable standards, federal/national regulations, Ex documentation (XA) and certificates.
- ▶ Document every repair and each conversion and enter them into the *W@M* life cycle management database.

13.2 Spare parts

W@M Device Viewer (www.endress.com/deviceviewer):

All the spare parts for the measuring device, along with the order code, are listed here and can be ordered. If available, users can also download the associated Installation Instructions.

-  Measuring device serial number:
 - Is located on the nameplate of the device.
 - Can be read out via the **Serial number** parameter (→  161) in the **Device information** submenu.

13.3 Endress+Hauser services

Endress+Hauser offers a wide range of services.

-  Your Endress+Hauser Sales Center can provide detailed information on the services.

13.4 Return

The requirements for safe device return can vary depending on the device type and national legislation.

1. Refer to the website for more information:
<http://www.endress.com/support/return-material>
2. Return the device if repairs or a factory calibration are required, or if the wrong device was ordered or delivered.

13.5 Disposal



If required by the Directive 2012/19/EU on waste electrical and electronic equipment (WEEE), the product is marked with the depicted symbol in order to minimize the disposal of WEEE as unsorted municipal waste. Do not dispose of products bearing this marking as unsorted municipal waste. Instead, return them to Endress+Hauser for disposal under the applicable conditions.

13.5.1 Removing the measuring device

1. Switch off the device.

⚠ WARNING

Danger to persons from process conditions.

- ▶ Beware of hazardous process conditions such as pressure in the measuring device, high temperatures or aggressive fluids.
2. Carry out the mounting and connection steps from the "Mounting the measuring device" and "Connecting the measuring device" sections in reverse order. Observe the safety instructions.

13.5.2 Disposing of the measuring device

⚠ WARNING

Danger to personnel and environment from fluids that are hazardous to health.

- ▶ Ensure that the measuring device and all cavities are free of fluid residues that are hazardous to health or the environment, e.g. substances that have permeated into crevices or diffused through plastic.

Observe the following notes during disposal:











- ▶ Observe valid federal/national regulations.
- ▶ Ensure proper separation and reuse of the device components.



14 Accessories

Various accessories, which can be ordered with the device or subsequently from Endress+Hauser, are available for the device. Detailed information on the order code in question is available from your local Endress+Hauser sales center or on the product page of the Endress+Hauser website: www.endress.com.



14.1 Device-specific accessories

14.1.1 For the transmitter



Accessories	Description
Transmitter Proline 500 – digital	<p>Transmitter for replacement or storage. Use the order code to define the following specifications:</p> <ul style="list-style-type: none"> ▪ Approvals ▪ Output ▪ Input ▪ Display/operation ▪ Housing ▪ Software <p> Proline 500 – digital transmitter: Order number: 6X5BXX-*****A</p> <p> Proline 500 transmitter for replacement: It is essential to specify the serial number of the current transmitter when ordering. Based on the serial number, the device-specific data (e.g., calibration factors) of the replacement device can be used for the new transmitter.</p> <p> Proline 500 – digital transmitter: Installation Instructions EA01287D</p>
External WLAN antenna	<p>External WLAN antenna with 1.5 m (59.1 in) connecting cable and two angle brackets. Order code for "Accessory enclosed", option P8 "Wireless antenna wide area".</p> <ul style="list-style-type: none">  The external WLAN antenna is not suitable for use in hygienic applications. ▪ Further information on the WLAN interface →  70. <p> Order number: 71351317</p> <p> Installation Instructions EA01238D</p>
Pipe mounting set	<p>Pipe mounting set for transmitter.</p> <p> Proline 500 – digital transmitter Order number: 71346427</p> <p> Installation Instructions EA01195D</p>
Protective cover Transmitter Proline 500 – digital	<p>Is used to protect the measuring device from the effects of the weather: e.g. rainwater, excess heating from direct sunlight.</p> <p> Proline 500 – digital transmitter Order number: 71343504</p> <p> Installation Instructions EA01191D</p>

Display guard Proline 500 – digital	<p>Is used to protect the display against impact or scoring from sand in desert areas.</p> <p> Order number: 71228792</p> <p> Installation Instructions EA01093D</p>
Connecting cable Proline 500 – digital Sensor – Transmitter	<p>The connecting cable can be ordered directly with the measuring device (order code for "Cable, sensor connection) or as an accessory (order number).</p> <p>The following cable lengths are available: order code for "Cable, sensor connection"</p> <ul style="list-style-type: none"> ▪ Option B: 20 m (65 ft) ▪ Option E: User configurable up to max. 50 m ▪ Option F: User configurable up to max. 165 ft <p> Maximum possible cable length for a Proline 500 – digital connecting cable: 300 m (1000 ft)</p>





14.2 Communication-specific accessories

Accessories	Description
Fieldgate FXA42	<p>Is used to transmit the measured values of connected 4 to 20 mA analog measuring devices, as well as digital measuring devices</p> <p> <ul style="list-style-type: none"> ▪ Technical Information TI01297S ▪ Operating Instructions BA01778S ▪ Product page: www.endress.com/fxa42 </p>
Field Xpert SMT70	<p>The Field Xpert SMT70 tablet PC for device configuration enables mobile plant asset management in hazardous and non-hazardous areas. It is suitable for commissioning and maintenance staff to manage field instruments with a digital communication interface and to record progress.</p> <p>This tablet PC is designed as an all-in-one solution with a preinstalled driver library and is an easy-to-use, touch-sensitive tool which can be used to manage field instruments throughout their entire life cycle.</p> <p> <ul style="list-style-type: none"> ▪ Technical Information TI01342S ▪ Operating Instructions BA01709S ▪ Product page: www.endress.com/smt70 </p>
Field Xpert SMT77	<p>The Field Xpert SMT77 tablet PC for device configuration enables mobile plant asset management in areas categorized as Ex Zone 1.</p> <p> <ul style="list-style-type: none"> ▪ Technical Information TI01418S ▪ Operating Instructions BA01923S ▪ Product page: www.endress.com/smt77 </p>

14.3 Service-specific accessories

Accessories	Description
Applicator	<p>Software for selecting and sizing Endress+Hauser measuring devices:</p> <ul style="list-style-type: none"> Choice of measuring devices for industrial requirements Calculation of all the necessary data for identifying the optimum flowmeter: e.g. nominal diameter, pressure loss, flow velocity and accuracy. Graphic illustration of the calculation results Determination of the partial order code, administration, documentation and access to all project-related data and parameters over the entire life cycle of a project. <p>Applicator is available:</p> <ul style="list-style-type: none"> Via the Internet: https://portal.endress.com/webapp/applicator As a downloadable DVD for local PC installation.
W@M	<p>W@M Life Cycle Management</p> <p>Improved productivity with information at your fingertips. Data relevant to a plant and its components is generated from the first stages of planning and during the asset's complete life cycle.</p> <p>W@M Life Cycle Management is an open and flexible information platform with online and on-site tools. Instant access for your staff to current, in-depth data shortens your plant's engineering time, speeds up procurement processes and increases plant uptime.</p> <p>Combined with the right services, W@M Life Cycle Management boosts productivity in every phase. For more information, visit www.endress.com/lifecyclemanagement</p>
FieldCare	<p>FDT-based plant asset management tool from Endress+Hauser.</p> <p>It can configure all smart field units in your system and helps you manage them. By using the status information, it is also a simple but effective way of checking their status and condition.</p> <p> Operating Instructions BA00027S and BA00059S</p>
DeviceCare	<p>Tool to connect and configure Endress+Hauser field devices.</p> <p> Innovation brochure IN01047S</p>

14.4 System components

Accessories	Description
Memograph M graphic data manager	<p>The Memograph M graphic data manager provides information on all the relevant measured variables. Measured values are recorded correctly, limit values are monitored and measuring points analyzed. The data are stored in the 256 MB internal memory and also on a SD card or USB stick.</p> <p> <ul style="list-style-type: none"> Technical Information TI00133R Operating Instructions BA00247R </p>
Ceraphant PTC31B	<p>The pressure transmitter for measuring the absolute and gauge pressure in gases, steam, liquids and dusts. It can be used to read in the operating pressure value.</p> <p> <ul style="list-style-type: none"> Technical Information TI01130P Operating Instructions BA01270P </p>
Cerabar PMC21	<p>The pressure transmitter for measuring the absolute and gauge pressure in gases, steam, liquids and dusts. It can be used to read in the operating pressure value.</p> <p> <ul style="list-style-type: none"> Technical Information TI01133P Operating Instructions BA01271P </p>
Cerabar S PMC71	<p>The pressure transmitter for measuring the absolute and gauge pressure of gases, steam and liquids. It can be used to read in the operating pressure value.</p> <p> <ul style="list-style-type: none"> Technical Information TI00383P Operating Instructions BA00271P </p>

15 Technical data

15.1 Application

The measuring device is intended only for the flow measurement of gases.

To ensure that the device remains in proper operating condition for its service life, use the measuring device only for media against which the process-wetted materials are sufficiently resistant.

15.2 Function and system design

Measuring principle

Mass flow measurement based on thermal measuring principle.

Measuring system

The measuring system consists of a transmitter and a sensor. The transmitter and sensor are mounted in physically separate locations. They are interconnected by connecting cables.

For information on the structure of the device →  15

15.3 Input

Measured variable

Measured process variables

- Mass flow
- Temperature

Calculated process variables

- Corrected volume flow
- Volume flow
- FAD volume flow
- Flow velocity
- Calorific value
- 2nd temperature heat difference
- Heat flow
- Energy flow
- Density

Process variables available for order

Order code for "Sensor version":

- Option SB "Bidirectional" measures the flow in both directions (»positive« and »negative« flow) and totalizes the flow in both directions. The device is calibrated in both directions.
- Option SC "Reverse flow detection" only measures the flow in the positive direction. The reverse flow is detected by the device but is not totalized. The device is only calibrated in the positive forward flow direction.

Order code for "Application package":

Option EV "Second gas group" enables the configuration of two different standard gases/gas mixtures in the device and allows the user to switch from one gas group to another using the status input or (if available) via bus communication.

Measuring range

The available measuring range depends on the choice of gas, size of the pipe and on whether flow conditioners are used. Each measuring device is calibrated individually with air under reference operating conditions. No recalibration is required in the case of customer-specific gases, as the device's Gas Engine functionality converts from air to these gases.

The measuring ranges calibrated for air are indicated in the following section. For information on other gases and process conditions, contact your sales organization or use the Applicator selection software.

SI units

Measuring range without flow conditioners

- Order code for "Sensor version; sensor; measuring tube", option SA "Unidirectional; stainless steel; stainless steel"
- Order code for "Sensor version; sensor; measuring tube", option HA "Unidirectional; Alloy; stainless steel"

DN [mm]	Calibration range [kg/h] (Air, 20°C, 1.013 bar a)		Calibration range [Nm ³ /h] (Air, 0°C, 1.013 bar a)	
	Minimum	Maximum	Minimum	Maximum
15	0.5	53	0.4	41
25	2	200	1.5	155
40	6	555	4.6	429
50	10	910	7.7	704

DN [mm]	Calibration range [kg/h] (Air, 20°C, 1.013 bar a)		Calibration range [Nm ³ /h] (Air, 0°C, 1.013 bar a)	
	Minimum	Maximum	Minimum	Maximum
65	15	1 450	11.6	1 122
80	20	2 030	15.5	1 570
100	38	3 750	29	2 900

Measuring range with order code for "Sensor option", option CS "1 flow conditioner"

DN [mm]	Calibration range [kg/h] (Air, 20°C, 1.013 bar a)		Calibration range [Nm ³ /h] (Air, 0°C, 1.013 bar a)	
	Minimum	Maximum	Minimum	Maximum
25	1	130	1.5	101
40	3	345	4.6	267
50	5	575	7.7	445
65	9	920	13.9	712
80	13	1 310	15.5	1 013
100	23	2 310	29	1 786

- Order code for "Sensor version; sensor; measuring tube:", option SB "Bidirectional; stainless steel; stainless steel"
- Order code for "Sensor version; sensor; measuring tube:", option SC "Reverse flow detection; stainless steel; stainless steel"

DN [mm]	Calibration range [kg/h] (Air, 20°C, 1.013 bar a)		Calibration range [Nm ³ /h] (Air, 0°C, 1.013 bar a)	
	Minimum	Maximum	Minimum	Maximum
25	1	130	1.5	101
40	3	345	4.6	267
50	5	575	7.7	445
65	9	920	13.9	712
80	13	1 310	15.5	1 013
100	23	2 310	29	1 786

Measuring range with order code for "Sensor option", option CT "2 flow conditioners"

DN [mm]	Calibration range [kg/h] (Air, 20°C, 1.013 bar a)		Calibration range [Nm ³ /h] (Air, 0°C, 1.013 bar a)	
	Minimum	Maximum	Minimum	Maximum
25	1	115	1.5	89
40	3	300	4.6	232
50	5	500	7.7	387
65	8	800	12.3	619
80	11	1 140	15.5	882
100	20	200	29	1 547

US units

Measuring range without flow conditioners

- Order code for "Sensor version; sensor; measuring tube", option SA "Unidirectional; stainless steel; stainless steel"
- Order code for "Sensor version; sensor; measuring tube", option HA "Unidirectional; Alloy; stainless steel"

DN [in]	Calibration range [lb/h] (Air, 68°F, 14.7 psi a)		Calibration range [SCFM] (Air, 59°F, 14.7 psi a)	
	Minimum	Maximum	Minimum	Maximum
½	1	106	0.2	23
1	4	400	0.9	87
1 ½	12	1 110	2.6	242
2	20	1 820	4.4	396
2 ½	30	2 900	6.5	632
3	40	4 061	8.7	884
4	76	7 501	16.6	1 634

Measuring range with order code for "Sensor option", option CS "1 flow conditioner"

DN [in]	Calibration range [lb/h] (Air, 68°F, 14.7 psi a)		Calibration range [SCFM] (Air, 59°F, 14.7 psi a)	
	Minimum	Maximum	Minimum	Maximum
1	2	260	0.4	57
1 ½	6	690	1.3	150
2	10	1 150	2.2	251
2 ½	18	1 840	3.9	401
3	26	2 620	5.7	571
4	46	4 621	10	1 006

- Order code for "Sensor version; sensor; measuring tube:", option SB "Bidirectional; stainless steel; stainless steel"
- Order code for "Sensor version; sensor; measuring tube:", option SC "Reverse flow detection; stainless steel; stainless steel"

DN [in]	Calibration range [lb/h] (Air, 68°F, 14.7 psi a)		Calibration range [SCFM] (Air, 59°F, 14.7 psi a)	
	Minimum	Maximum	Minimum	Maximum
1	2	260	0.4	57
1 ½	6	690	1.3	150
2	10	1 150	2.2	251
2 ½	18	1 840	3.9	401
3	26	2 620	5.7	571
4	46	4 621	10	1 006

Measuring range with order code for "Sensor option", option CT "2 flow conditioners"

DN [in]	Calibration range [lb/h] (Air, 68°F, 14.7 psi a)		Calibration range [SCFM] (Air, 59°F, 14.7 psi a)	
	Minimum	Maximum	Minimum	Maximum
1	2	230	0.4	50
1 ½	6	600	1.3	131
2	10	1 000	2.2	218
2 ½	16	1 600	3.5	349
3	22	2 280	4.8	497
4	40	4 001	8.7	871

The flow rates listed are only representative for the calibrated conditions and do not necessarily reflect the measuring capacity of the measuring device under operating conditions and the actual pipe internal diameters present on site. To make sure that the correct device version and sizing is selected to suit the application, contact the sales organization or use the Applicator selection software.

Special applications

High gas flow velocities (>70 m/s)

In the case of high gas flow velocities, it is advisable to read in the process pressure dynamically or to enter the pressure as accurately as possible, as a velocity-dependent correction is performed.

Light gases (hydrogen, helium)

- The reliable measurement of light gases can be difficult due to their very high thermal conductivity. Depending on the application, the flow rates of light gases are often particularly slow and the flow profiles are not sufficiently developed. The flows are frequently in the laminar flow range, while turbulent flow would actually be needed for optimum measurement.
- Despite loss of accuracy and linearity in applications with light gases and low flow rates, the device measures with a good degree of repeatability and is therefore suitable for monitoring flow conditions (e.g. leak detection).
- The recommended inlet runs must be doubled for light gases. →  23

Operable flow range

- 200:1 with factory calibration
- Up to 1000:1 with application-specific adjustment

Input signal

External values

The measuring device provides interfaces which allow values measured externally →  175 to be transmitted to the measuring device:

- Analog inputs 4-20 mA
- Digital inputs

Pressure values can be transmitted as absolute or gauge pressure. For gauge pressure, the atmospheric pressure must be known or specified by the customer.

Current input

The measured values are written from the automation system to the measuring device via the current input →  175.

Digital communication

The measured values are written from the automation system to the measuring device via Modbus RS485.

Current input 0/4 to 20 mA

Current input	0/4 to 20 mA (active/passive)
Current span	<ul style="list-style-type: none"> ▪ 4 to 20 mA (active) ▪ 0/4 to 20 mA (passive)
Resolution	1 μ A
Voltage drop	Typically: 0.6 to 2 V for 3.6 to 22 mA (passive)
Maximum input voltage	\leq 30 V (passive)
Open-circuit voltage	\leq 28.8 V (active)
Possible input variables	<ul style="list-style-type: none"> ▪ Pressure ▪ Temperature ▪ Mol-% (gas analyzer) ▪ External reference flow rate (in-situ adjustment)

Status input

Maximum input values	<ul style="list-style-type: none"> ▪ DC -3 to 30 V ▪ If status input is active (ON): $R_i > 3$ kΩ
Response time	Configurable: 5 to 200 ms
Input signal level	<ul style="list-style-type: none"> ▪ Low signal: DC -3 to +5 V ▪ High signal: DC 12 to 30 V
Assignable functions	<ul style="list-style-type: none"> ▪ Off ▪ Reset the individual totalizers separately ▪ Reset all totalizers ▪ Flow override ▪ Second gas group ▪ Zero point adjustment

15.4 Output

Output signal

Modbus RS485

Physical interface	RS485 in accordance with EIA/TIA-485 standard
Terminating resistor	Integrated, can be activated via DIP switches

Current output 4 to 20 mA

Signal mode	Can be set to: <ul style="list-style-type: none"> ■ Active ■ Passive
Current span	Can be set to: <ul style="list-style-type: none"> ■ 4 to 20 mA NAMUR ■ 4 to 20 mA US ■ 4 to 20 mA ■ 0 to 20 mA (only if the signal mode is active) ■ Fixed current
Maximum output values	22.5 mA
Open-circuit voltage	DC 28.8 V (active)
Maximum input voltage	DC 30 V (passive)
Load	0 to 700 Ω
Resolution	0.38 μA
Damping	Configurable: 0 to 999.9 s
Assignable measured variables	<ul style="list-style-type: none"> ■ Mass flow ■ Volume flow ■ Corrected volume flow ■ FAD volume flow ■ Flow velocity ■ Temperature ■ Energy flow ■ Pressure ■ Density ■ Heat flow ■ Electronics temperature ■ 2nd temperature heat difference For SIL (application package), only mass flow

Pulse/frequency/switch output

Function	Can be set to pulse, frequency or switch output
Version	Open collector Can be set to: <ul style="list-style-type: none"> ■ Active ■ Passive ■ Passive NAMUR
Maximum input values	DC 30 V, 250 mA (passive)
Open-circuit voltage	DC 28.8 V (active)
Voltage drop	For 22.5 mA: ≤ DC 2 V
Pulse output	
Maximum input values	DC 30 V, 250 mA (passive)
Maximum output current	22.5 mA (active)
Open-circuit voltage	DC 28.8 V (active)

Pulse width	Configurable: 0.05 to 2 000 ms
Maximum pulse rate	10 000 Impulse/s
Pulse value	Adjustable
Assignable measured variables	<ul style="list-style-type: none"> ■ Mass flow ■ Volume flow ■ Corrected volume flow ■ FAD volume flow ■ Energy flow ■ Heat flow For SIL (application package), only mass flow
Frequency output	
Maximum input values	DC 30 V, 250 mA (passive)
Maximum output current	22.5 mA (active)
Open-circuit voltage	DC 28.8 V (active)
Output frequency	Adjustable: end value frequency 2 to 10 000 Hz ($f_{\max} = 12\,500$ Hz)
Damping	Configurable: 0 to 999.9 s
Pulse/pause ratio	1:1
Assignable measured variables	<ul style="list-style-type: none"> ■ Mass flow ■ Volume flow ■ Corrected volume flow ■ FAD volume flow ■ Flow velocity ■ Temperature ■ Energy flow ■ Pressure ■ Density ■ Heat flow ■ Electronics temperature ■ 2nd temperature heat difference For SIL (application package), only mass flow
Switch output	
Maximum input values	DC 30 V, 250 mA (passive)
Open-circuit voltage	DC 28.8 V (active)
Switching behavior	Binary, conductive or non-conductive
Switching delay	Configurable: 0 to 100 s
Number of switching cycles	Unlimited
Assignable functions	<ul style="list-style-type: none"> ■ Off ■ On ■ Diagnostic behavior ■ Limit value <ul style="list-style-type: none"> ■ Off ■ Mass flow ■ Volume flow ■ Corrected volume flow ■ FAD volume flow ■ Heat flow ■ Energy flow ■ Flow velocity ■ Density ■ Calorific value ■ Temperature ■ 2nd temperature heat difference ■ Totalizer 1-3 ■ Electronics temperature ■ Flow direction monitoring ■ Status <ul style="list-style-type: none"> Low flow cut off

Relay output

Function	Switch output
Version	Relay output, galvanically isolated
Switching behavior	Can be set to: <ul style="list-style-type: none"> ▪ NO (normally open), factory setting ▪ NC (normally closed)
Maximum switching capacity (passive)	<ul style="list-style-type: none"> ▪ DC 30 V, 0.1 A ▪ AC 30 V, 0.5 A
Assignable functions	<ul style="list-style-type: none"> ▪ Off ▪ On ▪ Diagnostic behavior ▪ Limit value <ul style="list-style-type: none"> ▪ Off ▪ Mass flow ▪ Volume flow ▪ Corrected volume flow ▪ FAD volume flow ▪ Heat flow ▪ Energy flow ▪ Flow velocity ▪ Density ▪ Temperature ▪ 2nd temperature heat difference ▪ Totalizer 1-3 ▪ Electronics temperature ▪ Flow direction monitoring ▪ Status <ul style="list-style-type: none"> Low flow cut off

User-configurable input/output

One specific input or output is assigned to a user-configurable input/output (configurable I/O) during device commissioning.

The following inputs and outputs are available for assignment:

- Choice of current output: 4 to 20 mA (active), 0/4 to 20 mA (passive)
- Pulse/frequency/switch output
- Choice of current input: 4 to 20 mA (active), 0/4 to 20 mA (passive)
- Status input

Signal on alarm

Depending on the interface, failure information is displayed as follows:

Modbus RS485

Failure mode	Choose from: <ul style="list-style-type: none"> ▪ NaN value instead of current value ▪ Last valid value
---------------------	---

Current output 0/4 to 20 mA

4 to 20 mA

Failure mode	Choose from: <ul style="list-style-type: none"> ▪ 4 to 20 mA in accordance with NAMUR recommendation NE 43 ▪ 4 to 20 mA in accordance with US ▪ Min. value: 3.59 mA ▪ Max. value: 22.5 mA ▪ Freely definable value between: 3.59 to 22.5 mA ▪ Actual value ▪ Last valid value
---------------------	--

0 to 20 mA

Failure mode	Choose from: <ul style="list-style-type: none"> ■ Maximum alarm: 22 mA ■ Freely definable value between: 0 to 20.5 mA
---------------------	---

Pulse/frequency/switch output

Pulse output	
Failure mode	Choose from: <ul style="list-style-type: none"> ■ Actual value ■ No pulses
Frequency output	
Failure mode	Choose from: <ul style="list-style-type: none"> ■ Actual value ■ 0 Hz ■ Defined value ($f_{max} 2$ to 12 500 Hz)
Switch output	
Failure mode	Choose from: <ul style="list-style-type: none"> ■ Current status ■ Open ■ Closed

Relay output

Failure mode	Choose from: <ul style="list-style-type: none"> ■ Current status ■ Open ■ Closed
---------------------	---

Local display

Plain text display	With information on cause and remedial measures
Backlight	Red backlighting indicates a device error.

 Status signal as per NAMUR recommendation NE 107

Interface/protocol



- Via digital communication:
 - Modbus RS485
- Via service interface
 - CDI-RJ45 service interface
 - WLAN interface

Plain text display	With information on cause and remedial measures
---------------------------	---

Web browser

Plain text display	With information on cause and remedial measures
---------------------------	---



Light emitting diodes (LED)

Status information	Status indicated by various light emitting diodes The following information is displayed depending on the device version: <ul style="list-style-type: none"> ▪ Supply voltage active ▪ Data transmission active ▪ Device alarm/error has occurred  Diagnostic information via light emitting diodes →  144
---------------------------	--

Low flow cut off The switch points for low flow cut off are user-selectable.



Galvanic isolation The outputs are galvanically isolated from one another and from earth (PE).

Protocol-specific data

Protocol	Modbus Applications Protocol Specification V1.1
Response times	<ul style="list-style-type: none"> ▪ Direct data access: typically 25 to 50 ms ▪ Auto-scan buffer (data range): typically 3 to 5 ms
Device type	Slave
Slave address range	1 to 247
Broadcast address range	0
Function codes	<ul style="list-style-type: none"> ▪ 03: Read holding register ▪ 04: Read input register ▪ 06: Write single registers ▪ 08: Diagnostics ▪ 16: Write multiple registers ▪ 23: Read/write multiple registers
Broadcast messages	Supported by the following function codes: <ul style="list-style-type: none"> ▪ 06: Write single registers ▪ 16: Write multiple registers ▪ 23: Read/write multiple registers
Supported baud rate	<ul style="list-style-type: none"> ▪ 1 200 BAUD ▪ 2 400 BAUD ▪ 4 800 BAUD ▪ 9 600 BAUD ▪ 19 200 BAUD ▪ 38 400 BAUD ▪ 57 600 BAUD ▪ 115 200 BAUD
Data transfer mode	<ul style="list-style-type: none"> ▪ ASCII ▪ RTU
Data access	Each device parameter can be accessed via Modbus RS485.  For Modbus register information
System integration	Information on system integration →  74. <ul style="list-style-type: none"> ▪ Modbus RS485 information ▪ Function codes ▪ Register information ▪ Response time ▪ Modbus data map

15.5 Power supply

Terminal assignment →  36

Supply voltage	Order code for "Power supply"	Terminal voltage		Frequency range
	Option D	DC 24 V	±20%	–
	Option E	AC 100 to 240 V	–15 to +10%	50/60 Hz, ±4 Hz
	Option I	DC 24 V	±20%	–
AC 100 to 240 V		–15 to +10%	50/60 Hz, ±4 Hz	
Power consumption	Transmitter			
	Max. 10 W (active power)			
	switch-on current	Max. 36 A (<5 ms) as per NAMUR Recommendation NE 21		
Current consumption	Transmitter			
	<ul style="list-style-type: none"> ■ Max. 400 mA (24 V) ■ Max. 200 mA (110 V, 50/60 Hz; 230 V, 50/60 Hz) 			
Power supply failure	<ul style="list-style-type: none"> ■ Totalizers stop at the last value measured. ■ Depending on the device version, the configuration is retained in the device memory or in the pluggable data memory (HistoROM DAT). ■ Error messages (incl. total operated hours) are stored. 			
Electrical connection	→  38			
Potential equalization	→  42			
Terminals	Spring-loaded terminals: Suitable for strands and strands with ferrules. Conductor cross-section 0.2 to 2.5 mm ² (24 to 12 AWG).			
Cable entries	<ul style="list-style-type: none"> ■ Cable gland: M20 × 1.5 with cable ∅ 6 to 12 mm (0.24 to 0.47 in) ■ Thread for cable entry: <ul style="list-style-type: none"> ■ NPT ½" ■ G ½" ■ M20 			
Cable specification	→  32			

15.6 Performance characteristics

Reference operating conditions

- Error limits based on ISO 11631
- Dry air with +20 to +30 °C (+68 to +86 °F) at 0.8 to 1.5 bar (12 to 22 psi)
- Specifications as per calibration protocol
- Accuracy based on accredited calibration rigs that are traced to ISO 17025.

i To obtain measured errors, use the *Applicator* sizing tool → 169

Maximum measured error

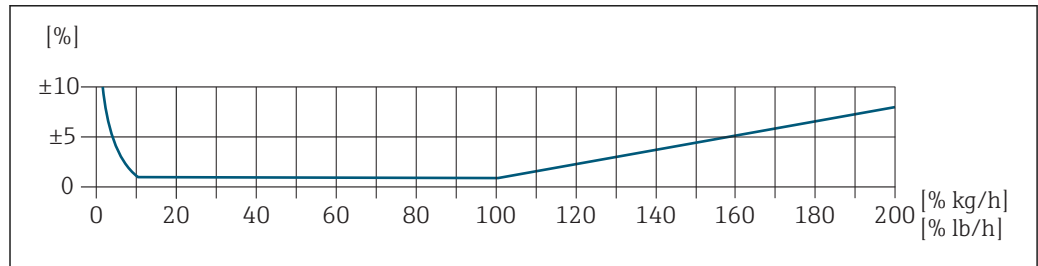

A0042739

Calibrated measuring range

The measuring accuracy is specified in relation to the mass flow and divided into two ranges:

- ±1.0 % of the current measured value for 100% to 10% of the calibrated measuring range (under reference operating conditions)
- ±0.10 % of the calibrated full scale value for 10% to 1% of the calibrated measuring range (under reference operating conditions)

The measuring device is calibrated and adjusted on an accredited and traceable calibration rig and its accuracy is certified in a calibration report ¹⁾ (5 control points).

Order code for "Calibration flow":

- Option G "Factory calibration": calibration report (5 control points)
- Option K "Traceable ISO/IEC17025": Swiss Calibration Services (SCS) calibration report (5 control points) which confirms traceability to the national calibration standard

i For information on calibrated measuring ranges and maximum full scale values → 171

Extended measuring range

The device has an extended measuring range that goes beyond the maximum calibrated value (100%). Here, the last measured values in the calibrated range are taken and then extrapolated. The end of the extrapolated range is only reached once the productive energy of the sensor is exceeded and/or the Mach number is greater than listed below.

Mach number	Order code
0.2	<ul style="list-style-type: none"> ▪ Order code for "Sensor version; sensor; measuring tube:", option SB "Bidirectional; stainless steel; stainless steel" ▪ Order code for "Sensor version; sensor; measuring tube:", option SC "Reverse flow detection; stainless steel; stainless steel"
0.4	<ul style="list-style-type: none"> ▪ Order code for "Sensor version; sensor; measuring tube:", option SA "Unidirectional; stainless steel; stainless steel" ▪ Order code for "Sensor version; sensor; measuring tube:", option HA "Unidirectional; Alloy; stainless steel"

1) Two calibration reports for the order code for "Sensor version; sensor; measuring tube:", option SB "Bidirectional; stainless steel; stainless steel"

The accuracy is specified in relation to the mass flow.
 $\pm 1.0\% \pm (\text{current measured value in } \% - 100\%) \times 0.07$ for 100% to 200% of the calibrated measuring range (under reference operating conditions)

Accuracy of outputs

The outputs have the following base accuracy specifications.

Current output

Accuracy	$\pm 5 \mu\text{A}$
----------	---------------------

Pulse/frequency output

o.r. = of reading

Accuracy	Max. ± 50 ppm o.r. (over the entire ambient temperature range)
----------	--

Repeatability $\pm 0.25\%$ of the display value for velocities above 1.0 m/s (3.3 ft/s)

Response time Typically < 3 s for 63 % of a step change (in both directions)

Influence of ambient temperature

Current output

Temperature coefficient	Max. $1 \mu\text{A}/^\circ\text{C}$
-------------------------	-------------------------------------

Pulse/frequency output

Temperature coefficient	No additional effect. Included in accuracy.
-------------------------	---

Influence of medium temperature Air: 0.02 % per $^\circ\text{C}$ (0.036 % per $^\circ\text{F}$) of the process temperature change in relation to the reference temperature

Influence of medium pressure Air: 0.3 % per bar (0.02 % per psi) of the process pressure change (from the set process pressure)

15.7 Installation



Installation conditions →  21

15.8 Environment

Ambient temperature range

Measuring device	<ul style="list-style-type: none"> ■ -40 to $+60$ $^\circ\text{C}$ (-40 to $+140$ $^\circ\text{F}$) ■ Order code for "Test, certificate", option JP: -50 to $+60$ $^\circ\text{C}$ (-58 to $+140$ $^\circ\text{F}$)
Readability of the local display	-20 to $+60$ $^\circ\text{C}$ (-4 to $+140$ $^\circ\text{F}$) The readability of the display may be impaired at temperatures outside the temperature range.

- ▶ If operating outdoors:
Avoid direct sunlight, particularly in warm climatic regions.

 You can order a weather protection cover from Endress+Hauser →  167.

Storage temperature -50 to +80 °C (-58 to +176 °F), preferably at +20 °C (+68 °F)

Atmosphere If a plastic transmitter housing is permanently exposed to certain steam and air mixtures, this can damage the housing.

 In cases of doubt, please contact the Sales Center.

Degree of protection

Transmitter

- As standard: IP66/67, type 4X enclosure
- When housing is open: IP20, type 1 enclosure
- Display module: IP20, type 1 enclosure

Sensor

- As standard: IP66/67, type 4X enclosure
- With the order code for "Sensor option", IP68 can also be ordered:
Option CC "IP68, Type 6P, cust-potted"

External WLAN antenna

IP67

Vibration- and shock-
resistance

Vibration sinusoidal, in accordance with IEC 60068-2-6

Sensor

- 2 to 8.4 Hz, 3.5 mm peak
- 8.4 to 2 000 Hz, 1 g peak

Transmitter

- 2 to 8.4 Hz, 7.5 mm peak
- 8.4 to 2 000 Hz, 2 g peak

Vibration broad-band random, according to IEC 60068-2-64

Sensor

- 10 to 200 Hz, 0.003 g²/Hz
- 200 to 2 000 Hz, 0.001 g²/Hz
- Total: 1.54 g rms

Transmitter

- 10 to 200 Hz, 0.01 g²/Hz
- 200 to 2 000 Hz, 0.003 g²/Hz
- Total: 2.70 g rms

Shock half-sine, according to IEC 60068-2-27

- Sensor
6 ms 30 g
- Transmitter
6 ms 50 g

Rough handling shocks according to IEC 60068-2-31

Interior cleaning

Suitable for cleaning-in-place (CIP) and sterilization-in-place (SIP).

Manufacturer options for delivery of parts

- Oil- and grease-free wetted parts, no declaration. Order code for "Service", option HA.
- Oil- and grease-free wetted parts as per IEC/TR 60877-2.0 and BOC 50000810-4, with declaration. Order code for "Service", option HB. The plant operator must ensure that the measuring device meets the requirements of the operator's oxygen application.

Electromagnetic
compatibility (EMC)

As per IEC/EN 61326 and NAMUR Recommendation 21 (NE 21)



Details are provided in the Declaration of Conformity.

15.9 Process

Medium temperature range Sensor
 -40 to +180 °C (-40 to +356 °F)

Medium pressure range Minimum 0.5 bar absolute. Maximum permitted medium pressure →  186

Pressure-temperature ratings The following pressure/temperature diagrams apply to all pressure-bearing parts of the device and not just the process connection. The diagrams show the maximum permissible medium pressure depending on the specific medium temperature.

Flange connection according to EN 1092-1 (DIN 2501/DIN 2512N)

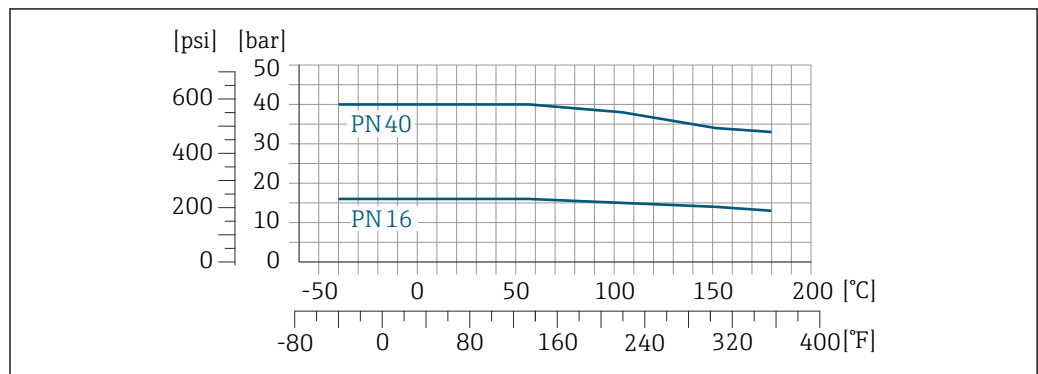

 39 With flange material 1.4404/F316L/F316

Flange connection according to JIS B2220

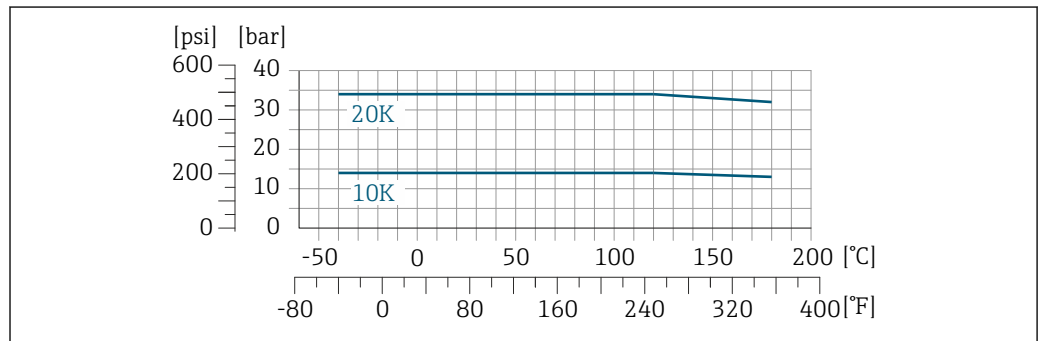

 40 With flange material 1.4404/F316L/F316

Flange connection as per ASME B16.5

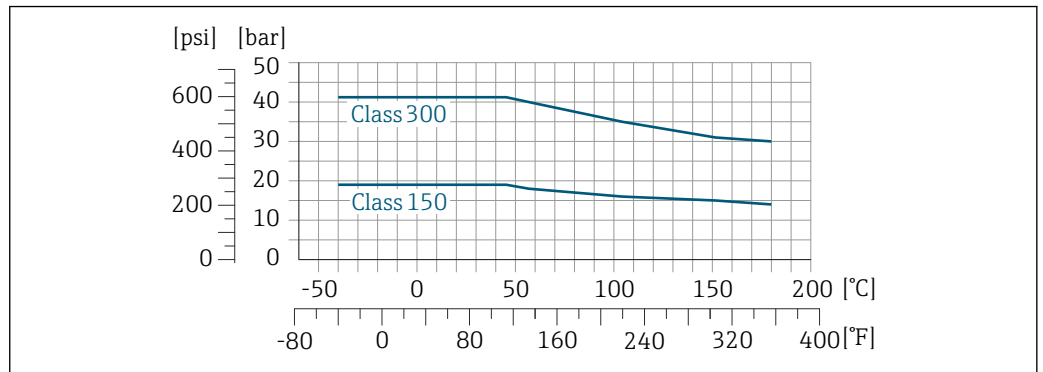

41 With flange material 1.4404/F316L/F316

A0041064-EN

Flow limit

Measuring range → 171

The maximum flow depends on the gas type and the pipe nominal diameter used. The end of the measuring range is reached when the Mach number listed below is reached.

Mach number	Order code
0.2	<ul style="list-style-type: none"> Order code for "Sensor version; sensor; measuring tube:", option SB "Bidirectional; stainless steel; stainless steel" Order code for "Sensor version; sensor; measuring tube:", option SC "Reverse flow detection; stainless steel; stainless steel"
0.4	<ul style="list-style-type: none"> Order code for "Sensor version; sensor; measuring tube:", option SA "Unidirectional; stainless steel; stainless steel" Order code for "Sensor version; sensor; measuring tube:", option HA "Unidirectional; Alloy; stainless steel"

Use the Applicator to size the device.

Pressure loss

Use the Applicator for precise calculations.

System pressure

→ 26

15.10 Mechanical construction

Design, dimensions

For the dimensions and installation lengths of the device, see the "Technical Information" document, "Mechanical construction" section.

Weight

Transmitter

- Proline 500 – digital polycarbonate: 1.4 kg (3.1 lbs)
- Proline 500 – digital aluminum: 2.4 kg (5.3 lbs)

Sensor

- Sensor with aluminum connection housing version: see the information in the following table
- Sensor with cast connection housing version, stainless: +3.7 kg (+8.2 lbs)

Weight in SI units

DN [mm]	Weight [kg]
15	4
25	5.2
40	7.4
50	9.8
65	13.1
80	16.8
100	25.6

Weight in US units

DN [in]	Weight [lbs]
½	9
1	11
1½	16
2	22
2½	29
3	37
4	56

Materials

Transmitter housing

Housing of Proline 500 – digital transmitter

Order code for "Transmitter housing":

- Option **A** "Aluminum coated": aluminum, AlSi10Mg, coated
- Option **D** "Polycarbonate": polycarbonate

Window material

Order code for "Transmitter housing":

- Option **A** "Aluminum, coated": glass
- Option **D** "Polycarbonate": plastic

Fastening components for mounting on a post

- Screws, threaded bolts, washers, nuts: stainless A2 (chrome-nickel steel)
- Metal plates: stainless steel, 1.4301 (304)

Sensor connection housing

Order code for "Sensor connection housing":

- Option **A** "Aluminum coated": aluminum, AlSi10Mg, coated
- Option **L** "Cast, stainless": 1.4409 (CF3M) similar to 316L

Cable entries/cable glands

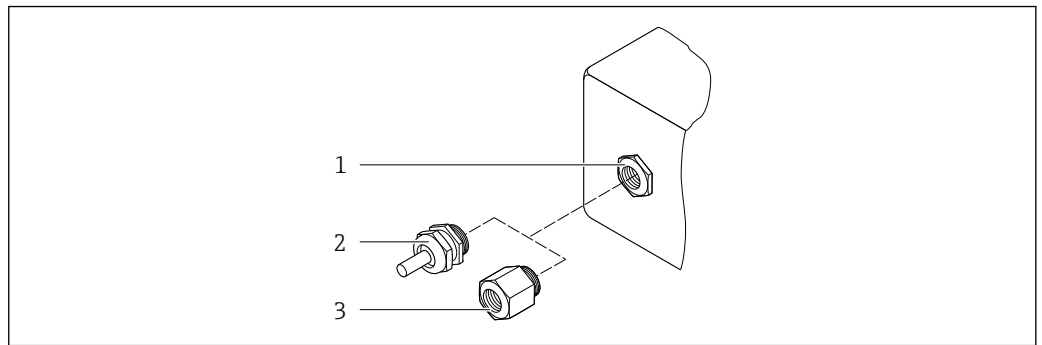

42 Possible cable entries/cable glands

- 1 Female thread M20 × 1.5
- 2 Cable gland M20 × 1.5
- 3 Adapter for cable entry with female thread G ½" or NPT ½"

Cable entries and adapters	Material
Cable gland M20 × 1.5	Plastic
<ul style="list-style-type: none"> ▪ Adapter for cable entry with female thread G ½" ▪ Adapter for cable entry with female thread NPT ½" <p>i Only available for certain device versions:</p> <ul style="list-style-type: none"> ▪ Order code for "Transmitter housing": <ul style="list-style-type: none"> ▪ Option A "Aluminum, coated" ▪ Option D "Polycarbonate" ▪ Order code for "Sensor connection housing": <ul style="list-style-type: none"> Proline 500 – digital: <ul style="list-style-type: none"> Option A "Aluminum coated" Option L "Cast, stainless" 	Nickel-plated brass

Measuring tubes

- DN 15 to 50 (½ to 2"): stainless cast steel, CF3M/1.4408
- DN 65 to 100 (2½ to 4"): stainless steel, 1.4404 (316/316L)

Process connections

Flange connections

Stainless steel, 1.4404 (F316/F316L)

Threaded connections

Stainless steel, 1.4404 (316/316L)

Sensing element

Unidirectional

- Stainless steel, 1.4404 (316/316L)
- Alloy C22, 2.4602 (UNS N06022);

Bidirectional

Stainless steel, 1.4404 (316/316L)

Reverse flow detection

Stainless steel, 1.4404 (316/316L)

Accessories

Protective cover



Stainless steel, 1.4404 (316L)

External WLAN antenna

- Antenna: ASA plastic (acrylic ester-styrene-acrylonitrile) and nickel-plated brass
- Adapter: Stainless steel and nickel-plated brass
- Cable: Polyethylene
- Plug: Nickel-plated brass
- Angle bracket: Stainless steel

Process connections

- EN 1092-1-B1
- ASME B16.5
- JIS B2220

 For information on the different materials used in the process connections →  189

15.11 Human interface

Languages

Can be operated in the following languages:

- Via local operation
English, German, French, Spanish, Italian, Dutch, Portuguese, Polish, Russian, Turkish, Chinese, Japanese, Korean, Bahasa (Indonesian), Vietnamese, Czech, Swedish
- Via Web browser
English, German, French, Spanish, Italian, Dutch, Portuguese, Polish, Russian, Turkish, Chinese, Japanese, Korean, Bahasa (Indonesian), Vietnamese, Czech, Swedish
- Via "FieldCare", "DeviceCare" operating tool: English, German, French, Spanish, Italian, Chinese, Japanese

Local operation

Via display module

Equipment:



- Order code for "Display; operation", option F "4-line, illuminated, graphic display; touch control"
- Order code for "Display; operation", option G "4-line, illuminated, graphic display; touch control + WLAN"

 Information about WLAN interface →  70

Display elements

- 4-line, illuminated, graphic display
- White background lighting; switches to red in event of device errors
- Format for displaying measured variables and status variables can be individually configured
- Permitted ambient temperature for the display: -20 to +60 °C (-4 to +140 °F)
The readability of the display may be impaired at temperatures outside the temperature range.

Operating elements

- External operation via touch control (3 optical keys) without opening the housing: , , 
- Operating elements also accessible in the various zones of the hazardous area



Remote operation

→  69

Service interface

→  69

Supported operating tools Different operating tools can be used for local or remote access to the measuring device. Depending on the operating tool used, access is possible with different operating units and via a variety of interfaces.

Supported operating tools	Operating unit	Interface	Additional information
Web browser	Notebook, PC or tablet with Web browser	<ul style="list-style-type: none"> ▪ CDI-RJ45 service interface ▪ WLAN interface 	Special Documentation for device
DeviceCare SFE100	Notebook, PC or tablet with Microsoft Windows system	<ul style="list-style-type: none"> ▪ CDI-RJ45 service interface ▪ WLAN interface ▪ Fieldbus protocol 	→  169
FieldCare SFE500	Notebook, PC or tablet with Microsoft Windows system	<ul style="list-style-type: none"> ▪ CDI-RJ45 service interface ▪ WLAN interface ▪ Fieldbus protocol 	→  169

 Other operating tools based on FDT technology with a device driver such as DTM/iDTM or DD/EDD can be used for device operation. These operating tools are available from the individual manufacturers. Integration into the following operating tools, among others, is supported:

- Field Device Manager (FDM) by Honeywell → www.honeywellprocess.com
- FieldMate by Yokogawa → www.yokogawa.com
- PACTWare → www.pactware.com

The associated device description files are available at: www.endress.com → Downloads

Web server

Thanks to the integrated Web server, the device can be operated and configured via a Web browser and via a service interface (CDI-RJ45) or via a WLAN interface. The structure of the operating menu is the same as for the local display. In addition to the measured values, status information on the device is also displayed and allows the user to monitor the status of the device. Furthermore the device data can be managed and the network parameters can be configured.

A device that has a WLAN interface (can be ordered as an option) is required for the WLAN connection: order code for "Display; operation", option G "4-line, illuminated; touch control + WLAN". The device acts as an Access Point and enables communication by computer or a mobile handheld terminal.

Supported functions

Data exchange between the operating unit (such as a notebook for example) and the measuring device:

- Upload the configuration from the measuring device (XML format, configuration backup)
- Save the configuration to the measuring device (XML format, restore configuration)
- Export event list (.csv file)
- Export parameter settings (.csv file or PDF file, document the measuring point configuration)
- Export the Heartbeat verification log (PDF file, only available with the "Heartbeat Verification" application package)
- Flash firmware version for device firmware upgrade, for instance
- Download driver for system integration
- Visualize up to 1000 saved measured values (only available with the **Extended HistoROM** application package →  197)

 Web server special documentation

HistoROM data management

The measuring device features HistoROM data management. HistoROM data management comprises both the storage and import/export of key device and process data, making operation and servicing far more reliable, secure and efficient.

 When the device is delivered, the factory settings of the configuration data are stored as a backup in the device memory. This memory can be overwritten with an updated data record, for example after commissioning.

Additional information on the data storage concept

There are different types of data storage units in which device data are stored and used by the device:

	Device memory	T-DAT	S-DAT
Available data	<ul style="list-style-type: none"> ▪ Event logbook such as diagnostic events for example ▪ Parameter data record backup ▪ Device firmware package 	<ul style="list-style-type: none"> ▪ Measured value logging ("Extended HistoROM" order option) ▪ Current parameter data record (used by firmware at run time) ▪ Peakhold indicator (min/max values) ▪ Totalizer values 	<ul style="list-style-type: none"> ▪ Sensor data: nominal diameter etc. ▪ Serial number ▪ Calibration data ▪ Device configuration (e.g. SW options, fixed I/O or multi I/O)
Storage location	Fixed on the user interface board in the connection compartment	Attachable to the user interface board in the connection compartment	In the sensor plug in the transmitter neck part

Data backup

Automatic

- The most important device data (sensor and transmitter) are automatically saved in the DAT modules
- If the transmitter or measuring device is replaced: once the T-DAT containing the previous device data has been exchanged, the new measuring device is ready for operation again immediately without any errors
- If the sensor is replaced: once the sensor has been replaced, new sensor data are transferred from the S-DAT in the measuring device and the measuring device is ready for operation again immediately without any errors
- If exchanging the electronics module (e.g. I/O electronics module): Once the electronics module has been replaced, the software of the module is compared against the current device firmware. The module software is upgraded or downgraded where necessary. The electronics module is available for use immediately afterwards and no compatibility problems occur.

Manual

Additional parameter data record (complete parameter settings) in the integrated device memory HistoROM backup for:

- Data backup function
Backup and subsequent restoration of a device configuration in the device memory HistoROM backup
- Data comparison function
Comparison of the current device configuration with the device configuration saved in the device memory HistoROM backup

Data transfer

Manual

Transfer of a device configuration to another device using the export function of the specific operating tool, e.g. with FieldCare, DeviceCare or Web server: to duplicate the configuration or to store in an archive (e.g. for backup purposes)

Event list

Automatic

- Chronological display of up to 20 event messages in the events list
- If the **Extended HistoROM** application package (order option) is enabled: up to 100 event messages are displayed in the events list along with a time stamp, plain text description and remedial measures
- The events list can be exported and displayed via a variety of interfaces and operating tools e.g. DeviceCare, FieldCare or Web server

Data logging

Manual

If the **Extended HistoROM** application package (order option) is enabled:

- Record up to 1 000 measured values via 1 to 4 channels
- User configurable recording interval
- Record up to 250 measured values via each of the 4 memory channels
- Export the measured value log via a variety of interfaces and operating tools e.g. FieldCare, DeviceCare or web server

15.12 Certificates and approvals

 Currently available certificates and approvals can be called up via the product configurator.

CE mark The device meets the legal requirements of the applicable EU Directives. These are listed in the corresponding EU Declaration of Conformity along with the standards applied.
Endress+Hauser confirms successful testing of the device by affixing to it the CE mark.

RCM-tick symbol The measuring system meets the EMC requirements of the "Australian Communications and Media Authority (ACMA)".

Ex approval The measuring device is certified for use in hazardous areas and the relevant safety instructions are provided in the separate "Safety Instructions" (XA) document. Reference is made to this document on the nameplate.

 The separate Ex documentation (XA) containing all the relevant explosion protection data is available from your Endress+Hauser sales center.

Proline 500 – digital

ATEX/IECEX

Currently, the following versions for use in hazardous areas are available:

Ex db

Transmitter		Sensor	
Category	Type of protection	Category	Type of protection
II(1)G	[Ex ia] IIC	II1/2G	Ex db ia IIC T4...T1 Ga/Gb
II(1)G	[Ex ia] IIC	II2G	Ex db ia IIC T4...T1 Gb
II3G	Ex ec nC [ia Ga] IIC T5...T1 Gc	II1/2G	Ex db ia IIC T4...T1 Ga/Gb
II3G	Ex ec nC [ia Ga] IIC T5...T1 Gc	II2G	Ex db ia IIC T4...T1 Gb

Ex tb

Transmitter		Sensor	
Category	Type of protection	Category	Type of protection
II(1)D	[Ex ia] IIIC	II2D	Ex tb IIIC T** °C Db

Non-Ex / Ex ec

Transmitter		Sensor	
Category	Type of protection	Category	Type of protection
Non - Ex	Non-Ex	II3G	Ex ec IIC T4...T1 Gc
II3G	Ex ec nC IIC T5...T1 Gc	II3G	Ex ec IIC T4...T1 Gc

cCSA_{US}

Currently, the following versions for use in hazardous areas are available:

IS (Ex nA, Ex i)

Transmitter	Sensor
Class I Division 2 Groups A - D	Class I, II, III Division 1 Groups A-G

NI (Ex nA)

Transmitter	Sensor
Class I Division 2 Groups A - D	Class I Division 2 Groups A - D

Ex db

Transmitter	Sensor
Ex ec nC [ia Ga] IIC T5...T1 Gc	Ex db ia IIC T4...T1 Gb
Ex ec nC [ia Ga] IIC T5...T1 Gc	Ex db ia IIC T4...T1 Ga/Gb

Ex nA

Transmitter	Sensor
Class I, Zone 2 AEx/ Ex nA IIC T5...T4 Gc	Class I, Zone 2 AEx/ Ex nA IIC T5...T1 Gc

Ex tb

Transmitter	Sensor
Non - Ex	Zone 21, AEx/Ex ia tb IIC T** °C Db

Functional safety

The measuring device can be used for flow monitoring systems (min., max., range) up to SIL 2 (single-channel architecture; order code for "Additional approval", option LA) and SIL 3 (multichannel architecture with homogeneous redundancy) and is independently evaluated and certified by the TÜV in accordance with IEC 61508.

The following types of monitoring in safety equipment are possible:
Mass flow



Functional Safety Manual with information on the SIL device

Radio approval

The measuring device has radio approval.



For detailed information regarding radio approval, see Special Documentation

Pressure Equipment Directive

- With the identification PED/G1/x (x = category) on the sensor nameplate, Endress+Hauser confirms conformity with the "Essential Safety Requirements" specified in Appendix I of the Pressure Equipment Directive 2014/68/EU.
- Devices not bearing this marking (PED) are designed and manufactured according to good engineering practice. They meet the requirements of Article 4 paragraph 3 of the Pressure Equipment Directive 2014/68/EU. The range of application is indicated in tables 6 to 9 in Annex II of the Pressure Equipment Directive 2014/68/EU.

Additional certification

CRN approval

Some device versions have CRN approval. A CRN-approved process connection with a CSA approval must be ordered for a CRN-approved device.

 Other standards and guidelines

- EN 60529
Degrees of protection provided by enclosures (IP code)
- EN 61010-1
Safety requirements for electrical equipment for measurement, control and laboratory use - general requirements
- IEC/EN 61326
Emission in accordance with Class A requirements. Electromagnetic compatibility (EMC requirements).
- NAMUR NE 21
Electromagnetic compatibility (EMC) of industrial process and laboratory control equipment
- NAMUR NE 32
Data retention in the event of a power failure in field and control instruments with microprocessors
- NAMUR NE 43
Standardization of the signal level for the breakdown information of digital transmitters with analog output signal.
- NAMUR NE 53
Software of field devices and signal-processing devices with digital electronics
- NAMUR NE 105
Specifications for integrating fieldbus devices in engineering tools for field devices
- NAMUR NE 107
Self-monitoring and diagnosis of field devices
- NAMUR NE 131
Requirements for field devices for standard applications



 Classification of process sealing between electrical systems and (flammable or combustible) process fluids in accordance with ANSI/ISA 12.27.01

Endress+Hauser devices are designed in accordance with ANSI/ISA 12.27.01, allowing the user to waive the use and save the cost of installing external secondary process seals in the conduit as required by the process sealing sections of ANSI/NFPA 70 (NEC) and CSA 22.1 (CEC). These devices comply with the North American installation practice and provide a very safe and cost-saving installation for pressurized applications with hazardous fluids. Further information can be found in the control drawings of the relevant devices.

15.13 Application packages

Many different application packages are available to enhance the functionality of the device. Such packages might be needed to address safety aspects or specific application requirements.

The application packages can be ordered with the device or subsequently from Endress+Hauser. Detailed information on the order code in question is available from your local Endress+Hauser sales center or on the product page of the Endress+Hauser website: www.endress.com.



 Detailed information on the application packages:
Special Documentation for the device →  198

Diagnostics functions	Package	Description
	Extended HistoROM	<p>Comprises extended functions concerning the event log and the activation of the measured value memory.</p> <p>Event log: Memory volume is extended from 20 message entries (standard version) to up to 100 entries.</p> <p>Data logging (line recorder):</p> <ul style="list-style-type: none"> ▪ Memory capacity for up to 1000 measured values is activated. ▪ 250 measured values can be output via each of the 4 memory channels. The recording interval can be defined and configured by the user. ▪ Measured value logs can be accessed via the local display or operating tool e.g. FieldCare, DeviceCare or Web server.

Heartbeat Technology	Package	Description
	Heartbeat Verification +Monitoring	<p>Heartbeat Verification Meets the requirement for traceable verification to DIN ISO 9001:2008 Chapter 7.6 a) "Control of monitoring and measuring equipment".</p> <ul style="list-style-type: none"> ▪ Functional testing in the installed state without interrupting the process. ▪ Traceable verification results on request, including a report. ▪ Simple testing process via local operation or other operating interfaces. ▪ Clear measuring point assessment (pass/fail) with high test coverage within the framework of manufacturer specifications. ▪ Extension of calibration intervals according to operator's risk assessment. <p>Heartbeat Monitoring Continuously supplies data, which are characteristic of the measuring principle, to an external condition monitoring system for the purpose of preventive maintenance or process analysis. These data enable the operator to:</p> <ul style="list-style-type: none"> ▪ Draw conclusions - using these data and other information - about the impact on the measuring performance over time. ▪ Schedule servicing in time. ▪ Monitor the process or product quality, e.g. process stability.

Second gas group	Package	Description
	Second gas group	This application package enables the configuration of two different standard gases/gas mixtures in the device and allows the user to switch from one gas group to another using the status input or (if available) via bus communication.

15.14 Accessories

 Overview of accessories available for order →  167

15.15 Supplementary documentation

 For an overview of the scope of the associated Technical Documentation, refer to the following:

- *W@M Device Viewer* (www.endress.com/deviceviewer): Enter the serial number from nameplate
- *Endress+Hauser Operations App*: Enter the serial number from the nameplate or scan the 2D matrix code (QR code) on the nameplate

Standard documentation **Brief Operating Instructions**

Brief Operating Instructions for the sensor

Measuring device	Documentation code
Proline t-mass F	KA01442D

Brief Operating Instructions for transmitter

Measuring device	Documentation code
Proline 500 – digital	KA01447D

Technical Information

Measuring device	Documentation code
t-mass F 500	TI01502D

Description of Device Parameters

Measuring device	Documentation code
t-mass 500	GP01146D

Device-dependent additional documentation

Safety instructions

Safety instructions for electrical equipment for hazardous areas.

Contents	Documentation code
ATEX/IECEX Ex d/Ex de	XA01970D
ATEX/IECEX Ex ec	XA01971D
cCSAus XP	XA01974D
cCSAus Ex d/ Ex de	XA01972D
cCSAus Ex nA	XA01973D

Remote display and operating module DKX001

Contents	Documentation code
ATEX/IECEX Ex i	XA01494D
ATEX/IECEX Ex ec	XA01498D
cCSAus IS	XA01499D
cCSAus Ex nA	XA01513D
INMETRO Ex i	XA01500D

Contents	Documentation code
INMETRO Ex ec	XA01501D
NEPSI Ex i	XA01502D
NEPSI Ex nA	XA01503D

Special Documentation

Contents	Documentation code
Information on the Pressure Equipment Directive	SD01614D
Remote display and operating module DKX001	SD01763D
Radio approvals for WLAN interface for A309/A310 display module	SD01793D
Web server	SD02488D
Heartbeat Technology	SD02480D

Installation Instructions

Contents	Comment
Installation instructions for spare part sets and accessories	<ul style="list-style-type: none"> ▪ Access the overview of all the available spare part sets via <i>W@M Device Viewer</i> →  165 ▪ Accessories available for order with Installation Instructions

Index

A

- About this document 6
- Access authorization to parameters
 - Read access 61
 - Write access 61
- Access code 61
 - Incorrect input 61
- Adapting the diagnostic behavior 152
- Additional certification 195
- Ambient temperature
 - Influence 183
- Application 170
- Approvals 194
- Auto scan buffer
 - see Modbus RS485 Modbus data map

C

- Cable entries
 - Technical data 181
 - Cable entry
 - Degree of protection 47
 - CE mark 12, 194
 - Certificates 194
 - Checklist
 - Post-connection check 48
 - Post-installation check 30
 - Cleaning
 - Cleaning the sensing element 163, 164
 - Exterior cleaning 163
 - Commissioning 79
 - Advanced settings 107
 - Configuring the measuring device 80
 - Compatibility 162
 - Configuring error response mode, Modbus RS485 152
 - Connecting cable 32
 - Connecting the connecting cable
 - Proline 500 – digital transmitter 40
 - Sensor connection housing, Proline 500 - digital 38
 - Terminal assignment of Proline 500 - digital 38
 - Connecting the measuring device
 - Proline 500 – digital 38
 - Connecting the signal cable/supply voltage cable
 - Proline 500 – digital transmitter 41
 - Connection
 - see Electrical connection
 - Connection preparations 37
 - Connection tools 32
 - Context menu
 - Calling up 58
 - Closing 58
 - Explanation 58
 - Current consumption 181
- ## D
- Date of manufacture 18
 - Declaration of Conformity 12

- Define access code 128
- Degree of protection 47, 184
- Designated use 10
- Device components 15
- Device description files 73
- Device documentation
 - Supplementary documentation 8
- Device history 162
- Device locking, status 131
- Device name
 - Sensor 18
 - Transmitter 17
- Device repair 165
- Device revision 73
- Device type ID 73
- DeviceCare 72
 - Device description file 73
- Diagnostic behavior
 - Explanation 148
 - Symbols 148
- Diagnostic information
 - Communication interface 152
 - Design, description 148, 151
 - DeviceCare 150
 - FieldCare 150
 - Light emitting diodes 144
 - Local display 147
 - Overview 153
 - Remedial measures 153
 - Web browser 149
- Diagnostic list 157
- Diagnostic message 147
- Diagnostics
 - Symbols 147
- DIP switch
 - see Write protection switch
- Direct access 59
- Direct access code 54
- Disabling write protection 127
- Display
 - see Onsite display
- Display area
 - For operational display 52
 - In the navigation view 54
- Display values
 - For locking status 131
- Disposal 166
- Document
 - Function 6
 - Symbols 6
- Document function 6

E

- Editing view 55
 - Input screen 56
 - Using operating elements 56, 57

- Electrical connection
 - Computer with Web browser (e.g. Internet Explorer) 69
 - Degree of protection 47
 - Measuring device 32
 - Operating tool (e.g. FieldCare, DeviceCare, AMS Device Manager, SIMATIC PDM) 69
 - Operating tools
 - Via Modbus RS485 protocol 69
 - Via service interface (CDI-RJ45) 69
 - Via WLAN interface 70
 - Web server 69
 - WLAN interface 70
- Electromagnetic compatibility 185
- Electronics module 15
- Enabling write protection 127
- Enabling/disabling the keypad lock 62
- Endress+Hauser services
 - Maintenance 164
 - Repair 165
- Environment
 - Storage temperature 184
 - Vibration- and shock-resistance 184
- Error messages
 - see Diagnostic messages
- Event list 157
- Event logbook 157
- Ex approval 194
- Extended order code
 - Sensor 18
 - Transmitter 17
- Exterior cleaning 163
- F**
- Field of application
 - Residual risks 11
- FieldCare 71
 - Device description file 73
 - Establishing a connection 71
 - Function 71
 - User interface 72
- Filtering the event logbook 158
- Firmware
 - Release date 73
 - Version 73
- Firmware history 161
- Flow conditioner 24
- Flow limit 187
- Function check 79
- Function codes 74
- Functional safety (SIL) 195
- Functions
 - see Parameters
- G**
- Galvanic isolation 180
- H**
- Hardware write protection 129
- Help text
 - Calling up 60
 - Closing 60
 - Explanation 60
- HistoROM 114, 124
- I**
- Identifying the measuring device 16
- Incoming acceptance 16
- Influence
 - Ambient temperature 183
 - Medium pressure 183
- Input 171
- Inspection
 - Connection 48
 - Received goods 16
- Inspection check
 - Installation 30
- Installation 21
- Installation conditions
 - Sensor heating 27
 - System pressure 26
- L**
- Languages, operation options 190
- Line recorder 138
- Local display 190
 - Navigation view 53
 - see Diagnostic message
 - see In alarm condition
 - see Operational display
- Low flow cut off 180
- M**
- Main electronics module 15
- Maintenance 163
- Maintenance tasks 163
 - Recalibration 164
- Managing the device configuration 114, 124
- Manufacturer ID 73
- Manufacturing date 17
- Materials 188
- Measured variables
 - see Process variables
- Measuring and test equipment 164
- Measuring device
 - Configuration 80
 - Conversion 165
 - Disposal 166
 - Preparing for electrical connection 37
 - Preparing for mounting 28
 - Removing 166
 - Repairs 165
 - Structure 15
 - Switch-on 79
- Measuring principle 170
- Measuring system 170
- Medium pressure
 - Influence 183

Menu		
Diagnostics	156	
Setup	81	
Menus		
For measuring device configuration	80	
For specific settings	107	
Modbus RS485		
Configuring error response mode	152	
Diagnostic information	152	
Function codes	74	
Modbus data map	76	
Read access	74	
Reading out data	77	
Register addresses	75	
Register information	75	
Response time	75	
Scan list	77	
Write access	74	
Mounting preparations	28	
Mounting tools	28	
N		
Nameplate		
Sensor	18	
Transmitter	17	
Navigation path (navigation view)	54	
Navigation view		
In the submenu	53	
In the wizard	53	
Numeric editor	55	
O		
Onsite display		
Numeric editor	55	
Text editor	56	
Operable flow range	174	
Operating elements	57, 148	
Operating keys		
see Operating elements		
Operating menu		
Menus, submenus	50	
Structure	50	
Submenus and user roles	51	
Operating philosophy	51	
Operation	131	
Operation options	49	
Operational display	52	
Operational safety	11	
Order code	17, 18	
Output	176	
Output signal	176	
P		
Packaging disposal	20	
Parameter		
Changing	60	
Entering values or text	60	
Parameter settings		
Adjustment values in use (Submenu)	122	
Administration (Submenu)	117	
Advanced setup (Submenu)	107	
Configuration backup (Submenu)	114, 124	
Current input	91	
Current input (Wizard)	91	
Current input 1 to n (Submenu)	134	
Current output	92	
Current output (Wizard)	92	
Data logging (Submenu)	138	
Define access code (Wizard)	116	
Device information (Submenu)	160	
Diagnostics (Menu)	156	
Display (Submenu)	109	
Display (Wizard)	102	
I/O configuration	90	
I/O configuration (Submenu)	90	
In-situ adjustment (Submenu)	120	
Low flow cut off (Wizard)	106	
Measurement mode (Wizard)	81	
Process variables (Submenu)	132	
Pulse/frequency/switch output	95	
Pulse/frequency/switch output (Wizard)	95, 96, 99	
Pulse/frequency/switch output 1 to n (Submenu)	136	
Reference conditions (Submenu)	85	
Relay output	101	
Relay output 1 to n (Submenu)	136	
Relay output 1 to n (Wizard)	101	
Reset access code (Submenu)	117	
Setup (Menu)	81	
Simulation (Submenu)	125	
Status input	87	
Status input (Submenu)	87	
Status input 1 to n (Submenu)	134	
System units (Submenu)	88	
System values (Submenu)	133	
Totalizer (Submenu)	133	
Totalizer 1 to n (Submenu)	107	
Totalizer handling (Submenu)	137	
Value current output 1 to n (Submenu)	135	
Web server (Submenu)	68	
WLAN settings (Wizard)	112	
Post-connection check (checklist)	48	
Post-installation check	79	
Post-installation check (checklist)	30	
Potential equalization	42	
Power consumption	181	
Power supply failure	181	
Pressure Equipment Directive	195	
Process connections	190	
Product safety	12	
Proline 500 – digital transmitter		
Connecting the signal cable/supply voltage cable	41	
Protecting parameter settings	127	
R		
Radio approval	195	
RCM-tick symbol	194	
Read access	61	
Reading measured values	131	

- Reading out diagnostic information, Modbus RS485 152
- Recalibration 164
- Registered trademarks 9
- Remedial measures
 - Calling up 149
 - Closing 149
- Remote operation 190
- Repair 165
- Repair of a device 165
- Repairs
 - Notes 165
- Replacement
 - Device components 165
- Requirements for personnel 10
- Response time 183
- Return 165
- S**
- Safety 10
- Sensor adjustment 87
- Sensor heating 27
- Serial number 17, 18
- Setting the operating language 79
- Settings
 - Adapting the measuring device to the process conditions 137
 - Administration 116
 - Advanced display configurations 109
 - Current input 91
 - Current output 92
 - Device reset 160
 - I/O configuration 90
 - In-situ adjustment 117
 - Local display 102
 - Low flow cut off 106
 - Managing the device configuration 114, 124
 - Measurement mode 81
 - Operating language 79
 - Pulse output 95
 - Pulse/frequency/switch output 95, 96
 - Reference operating conditions 85
 - Relay output 101
 - Resetting the totalizer 137
 - Simulation 125
 - Status input 87
 - Switch output 99
 - System units 88
 - Tag name 81
 - Totalizer 107
 - Totalizer reset 137
 - WLAN 112
- Showing data logging 138
- Signal on alarm 178
- SIL (functional safety) 195
- Software release 73
- Spare part 165
- Spare parts 165
- Special
 - Mounting instructions 27
- Special connection instructions 43
- Standards and guidelines 196
- Status area
 - For operational display 52
 - In the navigation view 54
- Status signals 147, 150
- Storage concept 192
- Storage conditions 19
- Storage temperature 19
- Storage temperature range 184
- Structure
 - Measuring device 15
 - Operating menu 50
- Submenu
 - Adjustment values in use 122
 - Administration 116, 117
 - Advanced setup 107
 - Configuration backup 114, 124
 - Current input 1 to n 134
 - Data logging 138
 - Device information 160
 - Display 109
 - Event list 157
 - I/O configuration 90
 - In-situ adjustment 120
 - Input values 134
 - Measured values 131
 - Output values 135
 - Overview 51
 - Process variables 132
 - Pulse/frequency/switch output 1 to n 136
 - Reference conditions 85
 - Relay output 1 to n 136
 - Reset access code 117
 - Simulation 125
 - Status input 87
 - Status input 1 to n 134
 - System units 88
 - System values 133
 - Totalizer 133
 - Totalizer 1 to n 107
 - Totalizer handling 137
 - Value current output 1 to n 135
 - Web server 68
- Supply voltage 181
- Switch output 178
- Symbols
 - Controlling data entries 57
 - For communication 52
 - For diagnostic behavior 52
 - For locking 52
 - For measured variable 52
 - For measurement channel number 52
 - For menus 54
 - For parameters 54
 - For status signal 52
 - For submenu 54
 - For wizard 54
 - In the status area of the local display 52

- Input screen 56
- Operating elements 56
- System design
 - Measuring system 170
 - see Measuring device design
- System integration 73
- System pressure 26
- T**
- Technical data, overview 170
- Temperature range
 - Ambient temperature range for display 190
 - Storage temperature 19
- Terminal assignment 36
- Terminal assignment of connecting cable for Proline
 - 500- digital
 - Sensor connection housing 38
- Terminals 181
- Text editor 56
- Tool
 - For mounting 28
- Tool tip
 - see Help text
- Tools
 - Electrical connection 32
 - Transport 19
- Totalizer
 - Configuration 107
- Transporting the measuring device 19
- Troubleshooting
 - General 142
- U**
- Use of the measuring device
 - Borderline cases 10
 - Incorrect use 10
 - see Designated use
- User interface
 - Current diagnostic event 156
 - Previous diagnostic event 156
- User roles 51
- V**
- Version data for the device 73
- Vibration- and shock-resistance 184
- W**
- W@M 164, 165
- W@M Device Viewer 16, 165
- Weight
 - SI units 188
 - Transport (notes) 19
 - US units 188
- Wizard
 - Current input 91
 - Current output 92
 - Define access code 116
 - Display 102
 - Low flow cut off 106
 - Measurement mode 81
- Pulse/frequency/switch output 95, 96, 99
- Relay output 1 to n 101
- WLAN settings 112
- WLAN settings 112
- Workplace safety 11
- Write access 61
- Write protection
 - Via access code 127
 - Via write protection switch 129
- Write protection switch 129

www.addresses.endress.com
