

Technical Information

Proline t-mass F 500

Thermal mass flowmeter

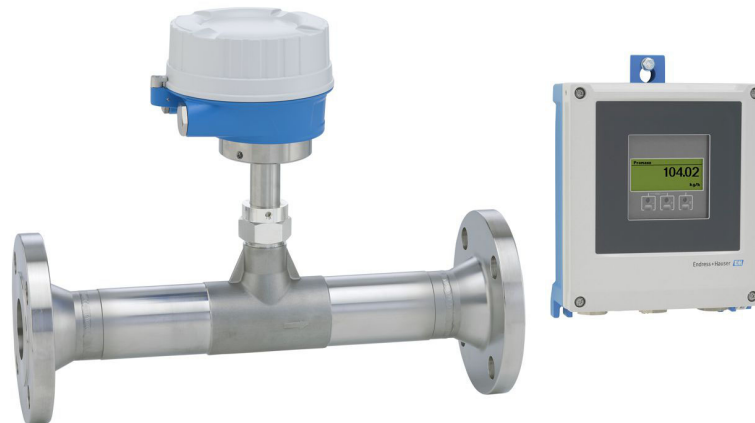

Inline flowmeter with long-term stability as remote version with up to 4 I/Os

Application

- Measuring principle is characterized by a high operable flow range and direct mass flow measurement
- Measurement of utility and process gases as well as gas mixtures in small line sizes

Device properties

- Inline version with DN 15 to 100 (½ to 4")
- Bidirectional measurement; high measuring performance
- Patented drift-free sensor with SIL 2
- Remote version with up to 4 I/Os
- Backlit display with touch control and WLAN access
- Standard cable between sensor and transmitter

Your benefits

- Flexible, convenient programming based on 21 standard gases or freely definable gas mixtures thereof
- High level of process control – premium measurement accuracy and repeatability
- Reliable monitoring – detection of process disturbances and reverse flow
- Easy maintenance – removable sensor
- Full access to process and diagnostic information – numerous, freely combinable I/Os and fieldbuses
- Reduced complexity and variety – freely configurable I/O functionality
- Integrated verification – Heartbeat Technology

Table of contents

About this document	4	Atmosphere	45
Symbols	4	Degree of protection	45
Function and system design	6	Vibration- and shock-resistance	45
Measuring principle	6	Interior cleaning	46
Measuring system	7	Electromagnetic compatibility (EMC)	46
Equipment architecture	9	Process	47
Dependability	9	Medium temperature range	47
Input	12	Medium pressure range	47
Measured variable	12	Pressure-temperature ratings	47
Measuring range	12	Flow limit	48
Operable flow range	15	Pressure loss	48
Input signal	15	Thermal insulation	48
Output	17	Heating	48
Output and input variants	17	Mechanical construction	50
Output signal	19	Dimensions in SI units	50
Signal on alarm	23	Dimensions in US units	55
Load	24	Materials	61
Ex connection data	24	Weight	62
Low flow cut off	25	Process connections	63
Galvanic isolation	25	Human interface	63
Protocol-specific data	25	Operating concept	63
Power supply	26	Languages	64
Terminal assignment	26	Local operation	64
Device plugs available	26	Remote operation	64
Pin assignment, device plug	27	Service interface	65
Supply voltage	27	Supported operating tools	66
Power consumption	27	HistoROM data management	68
Current consumption	27	Certificates and approvals	70
Power supply failure	27	CE mark	70
Electrical connection	28	RCM-tick symbol	70
Terminals	33	Ex approval	70
Cable entries	33	Functional safety	71
Cable specification	33	HART certification	71
Performance characteristics	37	Radio approval	71
Reference operating conditions	37	Pressure Equipment Directive	71
Maximum measured error	37	Additional certification	71
Repeatability	38	Other standards and guidelines	72
Response time	38	Classification of process sealing between electrical systems and (flammable or combustible) process fluids in accordance with ANSI/ISA 12.27.01	72
Influence of ambient temperature	38	Ordering information	73
Influence of medium temperature	38	Application packages	74
Influence of medium pressure	38	Diagnostics functions	74
Installation	39	Heartbeat Technology	74
Orientation	39	Second gas group	74
Installation instructions	39	Accessories	75
Pipes	39	Device-specific accessories	75
Inlet and outlet runs	40	Communication-specific accessories	76
Mounting the transmitter housing	44	Service-specific accessories	76
Environment	45	System components	77
Ambient temperature range	45		
Storage temperature	45		

Supplementary documentation	78
Standard documentation	78
Device-dependent additional documentation	78
Registered trademarks	79

About this document

Symbols

Electrical symbols

Symbol	Meaning
	Direct current
	Alternating current
	Direct current and alternating current
	Ground connection A grounded terminal which, as far as the operator is concerned, is grounded via a grounding system.
	Protective Earth (PE) A terminal which must be connected to ground prior to establishing any other connections. The ground terminals are situated inside and outside the device: <ul style="list-style-type: none"> ▪ Inner ground terminal: Connects the protective earth to the mains supply. ▪ Outer ground terminal: Connects the device to the plant grounding system.



Communication symbols

Symbol	Meaning
	Wireless Local Area Network (WLAN) Communication via a wireless, local network.
	LED Light emitting diode is off.
	LED Light emitting diode is on.
	LED Light emitting diode is flashing.

Symbols for certain types of information

Symbol	Meaning
	Permitted Procedures, processes or actions that are permitted.
	Preferred Procedures, processes or actions that are preferred.
	Forbidden Procedures, processes or actions that are forbidden.
	Tip Indicates additional information.
	Reference to documentation.
	Reference to page.
	Reference to graphic.
	Visual inspection.

Symbols in graphics

Symbol	Meaning
1, 2, 3, ...	Item numbers
1, 2, 3, ...	Series of steps
A, B, C, ...	Views
A-A, B-B, C-C, ...	Sections
	Hazardous area
	Safe area (non-hazardous area)
	Flow direction

Function and system design

Measuring principle

The thermal measuring principle is based on the cooling of a heated resistance thermometer (PT100) from which heat is extracted by the passing medium.

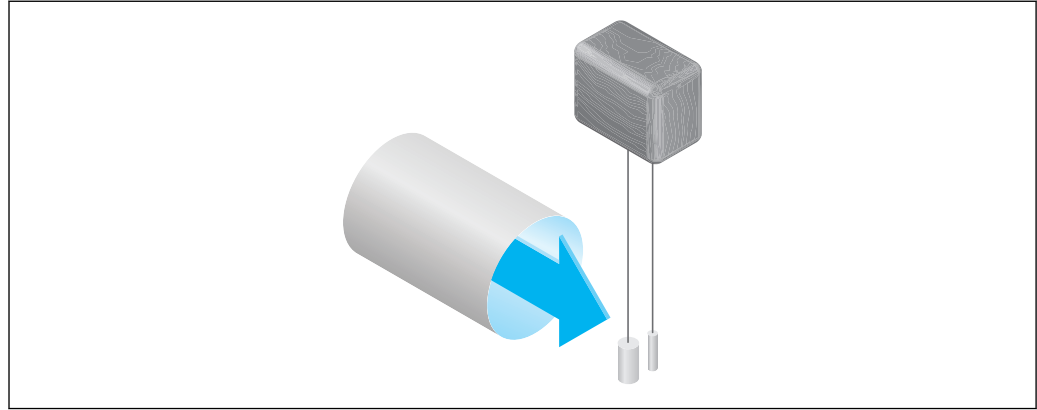

A0016823

The medium passes two PT100 resistance thermometers in the measurement section. One of these is used in the conventional way as a temperature sensor, while the other serves as a heating element. The temperature sensor monitors and records the effective process temperature while the heated resistance thermometer is kept at a constant differential temperature (compared to the measured process temperature) by controlling the electrical current used by the heating element. The greater the mass flow passing over the heated resistance thermometer, the greater the extent to which cooling takes place and therefore the stronger the current required to maintain a constant differential temperature. This means that the heat current measured is an indicator of the mass flow rate of the medium.

Gas Engine

The integrated Gas Engine functionality ensures maximum measuring performance for flow measurement. The Gas Engine developed by Endress+Hauser is a software-based database of typical standard gases and their specific properties. The Gas Engine calculates the properties of gas mixtures based on the percentage shares of up to 8 gas components.

The Gas Engine functionality enables:

- Calibration with air; no need for expensive and complex calibration with real gas
- Precise conversion of air to other gases; no recalibration required
- Exact measurement of single gases and also of gas mixtures
- Dynamic correction of pressure and temperature changes

The device can be configured for 21 freely selectable gases and water vapor.

Gases available for selection:

- | | | |
|---------------------|-------------------|-----------------------|
| ▪ Ammonia | ▪ Helium | ▪ Ozone ¹⁾ |
| ▪ Argon | ▪ Carbon dioxide | ▪ Propane |
| ▪ Butane | ▪ Carbon monoxide | ▪ Oxygen |
| ▪ Chlorine | ▪ Krypton | ▪ Hydrogen sulfide |
| ▪ Hydrogen chloride | ▪ Air | ▪ Nitrogen |
| ▪ Ethane | ▪ Methane | ▪ Hydrogen |
| ▪ Ethylene | ▪ Neon | ▪ Xenon |

1) Can only be selected as an individual gas or as a gas mixture with oxygen.

Mixtures of these gases, e.g. natural gas, can be programmed easily and quickly on the basis of the percentage shares.



For other gases, contact the Endress+Hauser sales organization responsible for your area.

Bidirectional measurement and reverse flow detection

Conventional thermal mass flowmeters cannot distinguish between forward and reverse flows. They always record flow in both directions with the same algebraic sign. Endress+Hauser's thermal flowmeter is available in this conventional unidirectional design, or as a bidirectional flowmeter. Both versions feature sensors that are protected in stainless steel. The bidirectional version can distinguish between the two flow directions and measure and totalize the flow in both directions with the same degree of accuracy.

The version to detect reverse flow only measures flow in the positive direction. The reverse flow is detected by the device but is not totalized.

Measuring system

The measuring system consists of a transmitter and a sensor. The transmitter and sensor are mounted in physically separate locations. They are interconnected by connecting cables.

Proline 500 – digital transmitter

For use in applications not required to meet special requirements due to ambient or operating conditions.

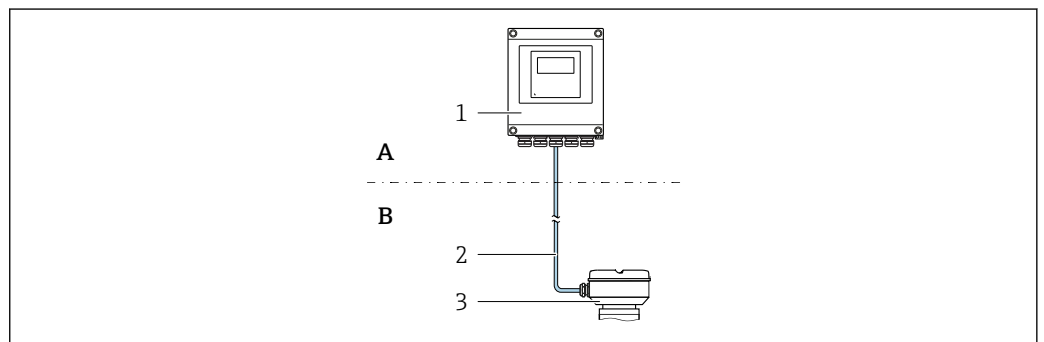

A Non-hazardous area or Zone 2; Class I, Division 2

B Non-hazardous area or Zone 2; Class I, Division 2 or Zone 1; Class I, Division 1

1 Transmitter

2 Connecting cable: cable, separate, standard

3 Sensor connection housing with integrated ISEM

- Electronics in the transmitter housing, ISEM (intelligent sensor electronics module) in the sensor connection housing
- Signal transmission: digital
- Order code for "Integrated ISEM electronics", option A "Sensor"

Connecting cable

Connecting cables can be ordered in various lengths → 75.

- Length:
 - Zone 2; Class I, Division 2: max. 300 m (1 000 ft)
 - Zone 1; Class I, Division 1: max. 150 m (500 ft)
- Standard cable with common shield (pair-stranded)
- Not sensitive to external EMC interference.

Hazardous area

Use in: Zone 2; Class I, Division 2

Mixed installation is possible:

- Sensor: Zone 1; Class I, Division 1
- Transmitter: Zone 2; Class I, Division 2

Device versions and materials

- Transmitter housing
 - Aluminum, coated: aluminum, AlSi10Mg, coated
 - Material: polycarbonate
- Material of window in transmitter housing
 - Aluminum, coated: glass
 - Material: polycarbonate

Configuration

- External operation via 4-line, backlit, graphic local display with touch control and guided menus ("Make-it-run" wizards) for application-specific commissioning.
- Via service interface or WLAN connection:
 - Operating tools (e.g. FieldCare, DeviceCare)
 - Web server (access via Web browser, e.g. Microsoft Internet Explorer, Microsoft Edge)

Sensor connection housing

Different versions of the connection housing are available.

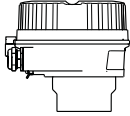
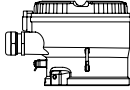
	Order code for "Sensor connection housing", option A, "Aluminum, coated": Aluminum, AlSi10Mg, coated
	Order code for "Sensor connection housing", option L, "Cast, stainless": 1.4409 (CF3M) similar to 316L

Sensor

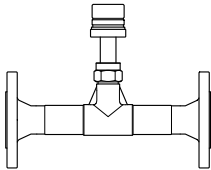
t-mass F 	In-line version: <ul style="list-style-type: none"> ■ Nominal diameter range: DN 15 to 100 (½ to 4") ■ Materials (in contact with medium): <ul style="list-style-type: none"> ■ Sensor: stainless steel 1.4404 (316/316L), 1.4408 (CF3M) ■ Sensing element: Stainless steel 1.4404 (316/316L) Alloy C22, 2.4602 as version for corrosive gases ■ Process connections: stainless steel 1.4404 (F316/F316L) ■ Exception: connecting part to transmitter (not in contact with medium): 1.4301 (304)
--	---

Equipment architecture

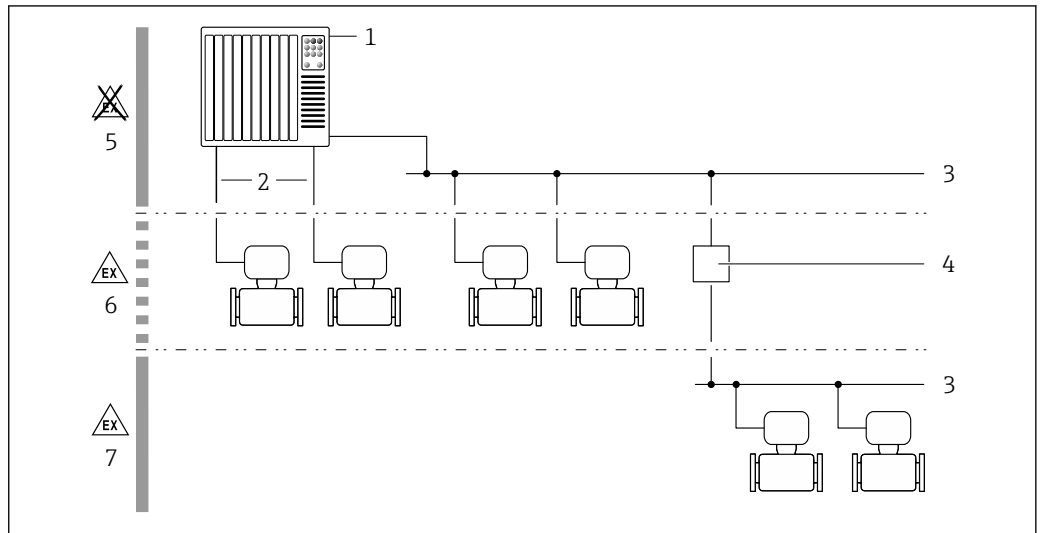

A0027512

1 Possibilities for integrating measuring devices into a system

- 1 Control system (e.g. PLC)
- 2 Connecting cable (0/4 to 20 mA HART etc.)
- 3 Fieldbus
- 4 Coupler
- 5 Non-hazardous area
- 6 Hazardous area: Zone 2; Class I, Division 2
- 7 Hazardous area: Zone 1; Class I, Division 1

Dependability

IT security

Our warranty is valid only if the device is installed and used as described in the Operating Instructions. The device is equipped with security mechanisms to protect it against any inadvertent changes to the settings.

IT security measures, which provide additional protection for the device and associated data transfer, must be implemented by the operators themselves in line with their security standards.

Device-specific IT security

The device offers a range of specific functions to support protective measures on the operator's side. These functions can be configured by the user and guarantee greater in-operation safety if used correctly. An overview of the most important functions is provided in the following section.

Function/interface	Factory setting	Recommendation
Write protection via hardware write protection switch → 10	Not enabled.	On an individual basis following risk assessment.
Access code (also applies for Web server login or FieldCare connection) → 10	Not enabled (0000).	Assign a customized access code during commissioning.
WLAN (order option in display module)	Enabled.	On an individual basis following risk assessment.
WLAN security mode	Enabled (WPA2-PSK)	Do not change.
WLAN passphrase (password) → 10	Serial number	Assign an individual WLAN passphrase during commissioning.
WLAN mode	Access Point	On an individual basis following risk assessment.
Web server → 10	Enabled.	On an individual basis following risk assessment.
CDI-RJ45 service interface → 10	-	On an individual basis following risk assessment.

Protecting access via hardware write protection

Write access to the device parameters via the local display, Web browser or operating tool (e.g. FieldCare, DeviceCare) can be disabled via a write protection switch (DIP switch on the motherboard). When hardware write protection is enabled, only read access to the parameters is possible.

Hardware write protection is disabled when the device is delivered.

Protecting access via a password

Different passwords are available to protect write access to the device parameters or access to the device via the WLAN interface.

- **User-specific access code**
Protect write access to the device parameters via the local display, Web browser or operating tool (e.g. FieldCare, DeviceCare). Access authorization is clearly regulated through the use of a user-specific access code.
- **WLAN passphrase**
The network key protects a connection between an operating unit (e.g. notebook or tablet) and the device via the WLAN interface which can be ordered as an option.
- **Infrastructure mode**
When the device is operated in infrastructure mode, the WLAN passphrase corresponds to the WLAN passphrase configured on the operator side.

User-specific access code

Write access to the device parameters via the local display, Web browser or operating tool (e.g. FieldCare, DeviceCare) can be protected by the modifiable, user-specific access code.

WLAN passphrase: Operation as WLAN access point

A connection between an operating unit (e.g. notebook or tablet) and the device via the WLAN interface, which can be ordered as an optional extra, is protected by the network key. The WLAN authentication of the network key complies with the IEEE 802.11 standard.

When the device is delivered, the network key is pre-defined depending on the device. It can be changed via the **WLAN settings** submenu in the **WLAN passphrase** parameter.

Infrastructure mode

A connection between the device and WLAN access point is protected by means of an SSID and passphrase on the system side. Please contact the relevant system administrator for access.

General notes on the use of passwords

- The access code and network key supplied with the device should be changed during commissioning.
- Follow the general rules for generating a secure password when defining and managing the access code or network key.
- The user is responsible for the management and careful handling of the access code and network key.

Access via Web server

The device can be operated and configured via a Web browser with the integrated Web server. The connection is via the service interface (CDI-RJ45) or the WLAN interface.

The Web server is enabled when the device is delivered. The Web server can be disabled if necessary (e.g. after commissioning) via the **Web server functionality** parameter.

The device and status information can be hidden on the login page. This prevents unauthorized access to the information.



For detailed information on device parameters, see:
The "Description of Device Parameters" document

Access via service interface (CDI-RJ45)

The device can be connected to a network via the service interface (CDI-RJ45). Device-specific functions guarantee the secure operation of the device in a network.

The use of relevant industrial standards and guidelines that have been defined by national and international safety committees, such as IEC/ISA62443 or the IEEE, is recommended. This includes organizational security measures such as the assignment of access authorization as well as technical measures such as network segmentation.

Input

Measured variable

Measured process variables

- Mass flow
- Temperature

Calculated process variables

- Corrected volume flow
- Volume flow
- FAD volume flow
- Flow velocity
- Calorific value
- 2nd temperature heat difference
- Heat flow
- Energy flow
- Density

Process variables available for order

Order code for "Sensor version":

- Option SB "Bidirectional" measures the flow in both directions (»positive« and »negative« flow) and totalizes the flow in both directions. The device is calibrated in both directions.
- Option SC "Reverse flow detection" only measures the flow in the positive direction. The reverse flow is detected by the device but is not totalized. The device is only calibrated in the positive forward flow direction.

Order code for "Application package":

Option EV "Second gas group" enables the configuration of two different standard gases/gas mixtures in the device and allows the user to switch from one gas group to another using the status input or (if available) via bus communication.

Measuring range

The available measuring range depends on the choice of gas, size of the pipe and on whether flow conditioners are used. Each measuring device is calibrated individually with air under reference operating conditions. No recalibration is required in the case of customer-specific gases, as the device's Gas Engine →  6 functionality converts from air to these gases.

The measuring ranges calibrated for air are indicated in the following section. For information on other gases and process conditions, contact your sales organization or use the Applicator selection software.

SI units

Measuring range without flow conditioners

- Order code for "Sensor version; sensor; measuring tube", option SA "Unidirectional; stainless steel; stainless steel"
- Order code for "Sensor version; sensor; measuring tube", option HA "Unidirectional; Alloy; stainless steel"

DN [mm]	Calibration range [kg/h] (Air, 20°C, 1.013 bar a)		Calibration range [Nm ³ /h] (Air, 0°C, 1.013 bar a)	
	Minimum	Maximum	Minimum	Maximum
15	0.5	53	0.4	41
25	2	200	1.5	155
40	6	555	4.6	429
50	10	910	7.7	704
65	15	1450	11.6	1122
80	20	2030	15.5	1570
100	38	3750	29	2900

Measuring range with order code for "Sensor option", option CS "1 flow conditioner"

DN [mm]	Calibration range [kg/h] (Air, 20°C, 1.013 bar a)		Calibration range [Nm ³ /h] (Air, 0°C, 1.013 bar a)	
	Minimum	Maximum	Minimum	Maximum
25	1	130	1.5	101
40	3	345	4.6	267
50	5	575	7.7	445
65	9	920	13.9	712
80	13	1 310	15.5	1 013
100	23	2 310	29	1 786

- Order code for "Sensor version; sensor; measuring tube:", option SB "Bidirectional; stainless steel; stainless steel"
- Order code for "Sensor version; sensor; measuring tube:", option SC "Reverse flow detection; stainless steel; stainless steel"

DN [mm]	Calibration range [kg/h] (Air, 20°C, 1.013 bar a)		Calibration range [Nm ³ /h] (Air, 0°C, 1.013 bar a)	
	Minimum	Maximum	Minimum	Maximum
25	1	130	1.5	101
40	3	345	4.6	267
50	5	575	7.7	445
65	9	920	13.9	712
80	13	1 310	15.5	1 013
100	23	2 310	29	1 786

Measuring range with order code for "Sensor option", option CT "2 flow conditioners"

DN [mm]	Calibration range [kg/h] (Air, 20°C, 1.013 bar a)		Calibration range [Nm ³ /h] (Air, 0°C, 1.013 bar a)	
	Minimum	Maximum	Minimum	Maximum
25	1	115	1.5	89
40	3	300	4.6	232
50	5	500	7.7	387
65	8	800	12.3	619
80	11	1 140	15.5	882
100	20	200	29	1 547

US units

Measuring range without flow conditioners

- Order code for "Sensor version; sensor; measuring tube", option SA "Unidirectional; stainless steel; stainless steel"
- Order code for "Sensor version; sensor; measuring tube", option HA "Unidirectional; Alloy; stainless steel"

DN [in]	Calibration range [lb/h] (Air, 68°F, 14.7 psi a)		Calibration range [SCFM] (Air, 59°F, 14.7 psi a)	
	Minimum	Maximum	Minimum	Maximum
½	1	106	0.2	23
1	4	400	0.9	87

DN [in]	Calibration range [lb/h] (Air, 68°F, 14.7 psi a)		Calibration range [SCFM] (Air, 59°F, 14.7 psi a)	
	Minimum	Maximum	Minimum	Maximum
1 ½	12	1 110	2.6	242
2	20	1 820	4.4	396
2 ½	30	2 900	6.5	632
3	40	4 061	8.7	884
4	76	7 501	16.6	1 634

Measuring range with order code for "Sensor option", option CS "1 flow conditioner"

DN [in]	Calibration range [lb/h] (Air, 68°F, 14.7 psi a)		Calibration range [SCFM] (Air, 59°F, 14.7 psi a)	
	Minimum	Maximum	Minimum	Maximum
1	2	260	0.4	57
1 ½	6	690	1.3	150
2	10	1 150	2.2	251
2 ½	18	1 840	3.9	401
3	26	2 620	5.7	571
4	46	4 621	10	1 006

- Order code for "Sensor version; sensor; measuring tube.", option SB "Bidirectional; stainless steel; stainless steel"
- Order code for "Sensor version; sensor; measuring tube.", option SC "Reverse flow detection; stainless steel; stainless steel"

DN [in]	Calibration range [lb/h] (Air, 68°F, 14.7 psi a)		Calibration range [SCFM] (Air, 59°F, 14.7 psi a)	
	Minimum	Maximum	Minimum	Maximum
1	2	260	0.4	57
1 ½	6	690	1.3	150
2	10	1 150	2.2	251
2 ½	18	1 840	3.9	401
3	26	2 620	5.7	571
4	46	4 621	10	1 006

Measuring range with order code for "Sensor option", option CT "2 flow conditioners"

DN [in]	Calibration range [lb/h] (Air, 68°F, 14.7 psi a)		Calibration range [SCFM] (Air, 59°F, 14.7 psi a)	
	Minimum	Maximum	Minimum	Maximum
1	2	230	0.4	50
1 ½	6	600	1.3	131
2	10	1 000	2.2	218
2 ½	16	1 600	3.5	349
3	22	2 280	4.8	497
4	40	4 001	8.7	871

The flow rates listed are only representative for the calibrated conditions and do not necessarily reflect the measuring capacity of the measuring device under operating conditions and the actual pipe internal diameters present on site. To make sure that the correct device version and sizing is selected to suit the application, contact the sales organization or use the Applicator selection software.

Special applications

High gas flow velocities (>70 m/s)

In the case of high gas flow velocities, it is advisable to read in the process pressure dynamically or to enter the pressure as accurately as possible, as a velocity-dependent correction is performed.

Light gases (hydrogen, helium)

- The reliable measurement of light gases can be difficult due to their very high thermal conductivity. Depending on the application, the flow rates of light gases are often particularly slow and the flow profiles are not sufficiently developed. The flows are frequently in the laminar flow range, while turbulent flow would actually be needed for optimum measurement.
- Despite loss of accuracy and linearity in applications with light gases and low flow rates, the device measures with a good degree of repeatability and is therefore suitable for monitoring flow conditions (e.g. leak detection).
- The recommended inlet runs must be doubled for light gases. →  40

Operable flow range

- 200:1 with factory calibration
- Up to 1000:1 with application-specific adjustment

Input signal

Output and input variants →  17

External values

The measuring device provides interfaces which allow values measured externally →  15 to be transmitted to the measuring device:

- Analog inputs 4-20 mA
- Digital inputs

Pressure values can be transmitted as absolute or gauge pressure. For gauge pressure, the atmospheric pressure must be known or specified by the customer.

HART protocol

The measured values are written from the automation system to the measuring device via the HART protocol. The pressure transmitter must support the following protocol-specific functions:

- HART protocol
- Burst mode

Current input

The measured values are written from the automation system to the measuring device via the current input →  15.

Digital communication

The measured values can be written from the automation system to the measuring via: Modbus RS485

Current input 0/4 to 20 mA

Current input	0/4 to 20 mA (active/passive)
Current span	<ul style="list-style-type: none"> ■ 4 to 20 mA (active) ■ 0/4 to 20 mA (passive)
Resolution	1 µA
Voltage drop	Typically: 0.6 to 2 V for 3.6 to 22 mA (passive)
Maximum input voltage	≤ 30 V (passive)

Open-circuit voltage	≤ 28.8 V (active)
Possible input variables	<ul style="list-style-type: none"> ▪ Pressure ▪ Temperature ▪ Mol-% (gas analyzer) ▪ External reference flow rate (in-situ adjustment)

Status input

Maximum input values	<ul style="list-style-type: none"> ▪ DC -3 to 30 V ▪ If status input is active (ON): $R_i > 3 \text{ k}\Omega$
Response time	Configurable: 5 to 200 ms
Input signal level	<ul style="list-style-type: none"> ▪ Low signal: DC -3 to +5 V ▪ High signal: DC 12 to 30 V
Assignable functions	<ul style="list-style-type: none"> ▪ Off ▪ Reset the individual totalizers separately ▪ Reset all totalizers ▪ Flow override ▪ Second gas group ▪ Zero point adjustment

Output

Output and input variants

Depending on the option selected for output/input 1, different options are available for the other outputs and inputs. Only one option can be selected for each output/input 1 to 4. The following tables must be read vertically (↓).

Example: If the option BA "4–20 mA HART" was selected for output/input 1, one of the options A, B, D, E, H, I or J is available for output 2 and one of the options A, B, D, E, H, I or J is available for output 3 and 4.

Output/input 1 and options for output/input 2

 Options for output/input 3 and 4

Order code for "Output; input 1" (020) →	Possible options										
Current output 4 to 20 mA HART	BA										
Current output 4 to 20 mA HART Ex i passive	↓	CA									
Current output 4 to 20 mA HART Ex i active		↓	CC								
Modbus RS485								↓	MA		
Order code for "Output; input 2" (021) →	↓	↓	↓	↓	↓	↓	↓	↓	↓	↓	↓
Not assigned	A	A	A	A	A	A	A	A	A	A	A
Current output 4 to 20 mA	B			B		B	B		B	B	B
Current output 4 to 20 mA Ex i passive		C	C		C			C			
User-configurable input/output ¹⁾	D			D		D	D		D	D	D
Pulse/frequency/switch output	E			E		E	E		E	E	E
Pulse/frequency/switch output Ex i passive		G	G		G			G			
Relay output	H			H		H	H		H	H	H
Current input 0/4 to 20 mA	I			I		I	I		I	I	I
Status input	J			J		J	J		J	J	J

1) A specific input or output can be assigned to a user-configurable input/output →  22.

Output/input 1 and options for output/input 3 and 4

 Options for output/input 2 →  17

Order code for "Output; input 1" (020) →	Possible options										
Current output 4 to 20 mA HART	BA										
Current output 4 to 20 mA HART Ex i passive	↓	CA									
Current output 4 to 20 mA HART Ex i active		↓	CC								
Modbus RS485								↓	MA		
Order code for "Output; input 3" (022), "Output; input 4" (023) →	↓	↓	↓	↓	↓	↓	↓	↓	↓	↓	↓
Not assigned	A	A	A	A	A	A	A	A	A	A	A
Current output 4 to 20 mA	B						B			B	B
Current output 4 to 20 mA Ex i passive ¹⁾		C	C								
User-configurable input/output	D						D			D	D
Pulse/frequency/switch output	E						E			E	E
Pulse/frequency/switch output Ex i passive ²⁾		G	G								
Relay output	H						H			H	H
Current input 0/4 to 20 mA	I						I			I	I
Status input	J						J			J	J

1) For output/input 4 the current output 4 to 20 mA Ex i passive (C) is not available.

2) For output/input 4 the pulse/frequency/switch output Ex i passive (G) is not available.

Output signal

Current output 4 to 20 mA HART

Order code	"Output; input 1" (20): Option BA: current output 4 to 20 mA HART
Signal mode	Can be set to: <ul style="list-style-type: none"> ■ Active ■ Passive
Current range	Can be set to: <ul style="list-style-type: none"> ■ 4 to 20 mA NAMUR ■ 4 to 20 mA US ■ 4 to 20 mA ■ 0 to 20 mA (only if the signal mode is active) ■ Fixed current
Open-circuit voltage	DC 28.8 V (active)
Maximum input voltage	DC 30 V (passive)
Load	250 to 700 Ω
Resolution	0.38 μ A
Damping	Configurable: 0 to 999.9 s
Assignable measured variables	<ul style="list-style-type: none"> ■ Mass flow ■ Volume flow ■ Corrected volume flow ■ FAD volume flow ■ Flow velocity ■ Temperature ■ Energy flow ■ Pressure ■ Density ■ Heat flow ■ Electronics temperature ■ 2nd temperature heat difference <p>For SIL (application package), only mass flow</p>

Current output 4 to 20 mA HART Ex i

Order code	"Output; input 1" (20) choose from: <ul style="list-style-type: none"> ■ Option CA: current output 4 to 20 mA HART Ex i passive ■ Option CC: current output 4 to 20 mA HART Ex i active
Signal mode	Depends on the selected order version.
Current range	Can be set to: <ul style="list-style-type: none"> ■ 4 to 20 mA NAMUR ■ 4 to 20 mA US ■ 4 to 20 mA ■ 0 to 20 mA (only if the signal mode is active) ■ Fixed current
Open-circuit voltage	DC 21.8 V (active)
Maximum input voltage	DC 30 V (passive)
Load	<ul style="list-style-type: none"> ■ 250 to 400 Ω (active) ■ 250 to 700 Ω (passive)
Resolution	0.38 μ A

Damping	Configurable: 0 to 999.9 s
Assignable measured variables	<ul style="list-style-type: none"> ■ Mass flow ■ Volume flow ■ Corrected volume flow ■ FAD volume flow ■ Flow velocity ■ Temperature ■ Energy flow ■ Pressure ■ Density ■ Heat flow ■ Electronics temperature ■ 2nd temperature heat difference <p>For SIL (application package), only mass flow</p>

Modbus RS485

Physical interface	RS485 in accordance with EIA/TIA-485 standard
Terminating resistor	Integrated, can be activated via DIP switches

Current output 4 to 20 mA

Order code	"Output; input 2" (21), "Output; input 3" (022) or "Output; input 4" (023): Option B: current output 4 to 20 mA
Signal mode	Can be set to: <ul style="list-style-type: none"> ■ Active ■ Passive
Current span	Can be set to: <ul style="list-style-type: none"> ■ 4 to 20 mA NAMUR ■ 4 to 20 mA US ■ 4 to 20 mA ■ 0 to 20 mA (only if the signal mode is active) ■ Fixed current
Maximum output values	22.5 mA
Open-circuit voltage	DC 28.8 V (active)
Maximum input voltage	DC 30 V (passive)
Load	0 to 700 Ω
Resolution	0.38 μA
Damping	Configurable: 0 to 999.9 s
Assignable measured variables	<ul style="list-style-type: none"> ■ Mass flow ■ Volume flow ■ Corrected volume flow ■ FAD volume flow ■ Flow velocity ■ Temperature ■ Energy flow ■ Pressure ■ Density ■ Heat flow ■ Electronics temperature ■ 2nd temperature heat difference <p>For SIL (application package), only mass flow</p>

Pulse/frequency/switch output

Function	Can be set to pulse, frequency or switch output
Version	Open collector Can be set to: <ul style="list-style-type: none"> ▪ Active ▪ Passive ▪ Passive NAMUR
Maximum input values	DC 30 V, 250 mA (passive)
Open-circuit voltage	DC 28.8 V (active)
Voltage drop	For 22.5 mA: ≤ DC 2 V
Pulse output	
Maximum input values	DC 30 V, 250 mA (passive)
Maximum output current	22.5 mA (active)
Open-circuit voltage	DC 28.8 V (active)
Pulse width	Configurable: 0.05 to 2 000 ms
Maximum pulse rate	10 000 Impulse/s
Pulse value	Adjustable
Assignable measured variables	<ul style="list-style-type: none"> ▪ Mass flow ▪ Volume flow ▪ Corrected volume flow ▪ FAD volume flow ▪ Energy flow ▪ Heat flow For SIL (application package), only mass flow
Frequency output	
Maximum input values	DC 30 V, 250 mA (passive)
Maximum output current	22.5 mA (active)
Open-circuit voltage	DC 28.8 V (active)
Output frequency	Adjustable: end value frequency 2 to 10 000 Hz ($f_{max} = 12\,500$ Hz)
Damping	Configurable: 0 to 999.9 s
Pulse/pause ratio	1:1
Assignable measured variables	<ul style="list-style-type: none"> ▪ Mass flow ▪ Volume flow ▪ Corrected volume flow ▪ FAD volume flow ▪ Flow velocity ▪ Temperature ▪ Energy flow ▪ Pressure ▪ Density ▪ Heat flow ▪ Electronics temperature ▪ 2nd temperature heat difference For SIL (application package), only mass flow
Switch output	
Maximum input values	DC 30 V, 250 mA (passive)
Open-circuit voltage	DC 28.8 V (active)
Switching behavior	Binary, conductive or non-conductive
Switching delay	Configurable: 0 to 100 s

Number of switching cycles	Unlimited
Assignable functions	<ul style="list-style-type: none"> ■ Off ■ On ■ Diagnostic behavior ■ Limit value <ul style="list-style-type: none"> ■ Off ■ Mass flow ■ Volume flow ■ Corrected volume flow ■ FAD volume flow ■ Heat flow ■ Energy flow ■ Flow velocity ■ Density ■ Calorific value ■ Temperature ■ 2nd temperature heat difference ■ Totalizer 1-3 ■ Electronics temperature ■ Flow direction monitoring ■ Status <ul style="list-style-type: none"> Low flow cut off

Relay output

Function	Switch output
Version	Relay output, galvanically isolated
Switching behavior	Can be set to: <ul style="list-style-type: none"> ■ NO (normally open), factory setting ■ NC (normally closed)
Maximum switching capacity (passive)	<ul style="list-style-type: none"> ■ DC 30 V, 0.1 A ■ AC 30 V, 0.5 A
Assignable functions	<ul style="list-style-type: none"> ■ Off ■ On ■ Diagnostic behavior ■ Limit value <ul style="list-style-type: none"> ■ Off ■ Mass flow ■ Volume flow ■ Corrected volume flow ■ FAD volume flow ■ Heat flow ■ Energy flow ■ Flow velocity ■ Density ■ Temperature ■ 2nd temperature heat difference ■ Totalizer 1-3 ■ Electronics temperature ■ Flow direction monitoring ■ Status <ul style="list-style-type: none"> Low flow cut off

User-configurable input/output

One specific input or output is assigned to a user-configurable input/output (configurable I/O) during device commissioning.

The following inputs and outputs are available for assignment:

- Choice of current output: 4 to 20 mA (active), 0/4 to 20 mA (passive)
- Pulse/frequency/switch output
- Choice of current input: 4 to 20 mA (active), 0/4 to 20 mA (passive)
- Status input

The technical values correspond to those of the inputs and outputs described in this section.

Signal on alarm

Depending on the interface, failure information is displayed as follows:

HART current output

Device diagnostics	Device condition can be read out via HART Command 48
---------------------------	--

Modbus RS485

Failure mode	Choose from: <ul style="list-style-type: none"> ▪ NaN value instead of current value ▪ Last valid value
---------------------	---

Current output 0/4 to 20 mA

4 to 20 mA

Failure mode	Choose from: <ul style="list-style-type: none"> ▪ 4 to 20 mA in accordance with NAMUR recommendation NE 43 ▪ 4 to 20 mA in accordance with US ▪ Min. value: 3.59 mA ▪ Max. value: 22.5 mA ▪ Freely definable value between: 3.59 to 22.5 mA ▪ Actual value ▪ Last valid value
---------------------	--

0 to 20 mA

Failure mode	Choose from: <ul style="list-style-type: none"> ▪ Maximum alarm: 22 mA ▪ Freely definable value between: 0 to 20.5 mA
---------------------	---

Pulse/frequency/switch output

Pulse output	
Failure mode	Choose from: <ul style="list-style-type: none"> ▪ Actual value ▪ No pulses
Frequency output	
Failure mode	Choose from: <ul style="list-style-type: none"> ▪ Actual value ▪ 0 Hz ▪ Defined value ($f_{max} 2$ to 12 500 Hz)
Switch output	
Failure mode	Choose from: <ul style="list-style-type: none"> ▪ Current status ▪ Open ▪ Closed

Relay output

Failure mode	Choose from: <ul style="list-style-type: none"> ▪ Current status ▪ Open ▪ Closed
---------------------	---

Local display



Plain text display	With information on cause and remedial measures
Backlight	Red backlighting indicates a device error.

 Status signal as per NAMUR recommendation NE 107

Interface/protocol

- Via digital communication:
 - HART protocol
 - Modbus RS485
- Via service interface
 - CDI-RJ45 service interface
 - WLAN interface

Plain text display	With information on cause and remedial measures
---------------------------	---

 Additional information on remote operation →  64

Web browser

Plain text display	With information on cause and remedial measures
---------------------------	---

Light emitting diodes (LED)

Status information	Status indicated by various light emitting diodes The following information is displayed depending on the device version: <ul style="list-style-type: none"> ▪ Supply voltage active ▪ Data transmission active ▪ Device alarm/error has occurred
---------------------------	---

Load Output signal →  19

Ex connection data**Safety-related values**

Order code for "Output; input 1"	Output type	Safety-related values "Output; input 1"	
		26 (+)	27 (-)
Option BA	Current output 4 to 20 mA HART	$U_N = 30 V_{DC}$ $U_M = 250 V_{AC}$	
Option MA	Modbus RS485	$U_N = 30 V_{DC}$ $U_M = 250 V_{AC}$	

Order code for "Output; input 2"; "Output; input 3" "Output; input 4"	Output type	Safety-related values					
		Output; input 2		Output; input 3		20 (+)	21 (-)
		24 (+)	25 (-)	22 (+)	23 (-)		
Option B	Current output 4 to 20 mA	$U_N = 30 V_{DC}$ $U_M = 250 V_{AC}$					
Option D	User-configurable input/ output	$U_N = 30 V_{DC}$ $U_M = 250 V_{AC}$					
Option E	Pulse/frequency/switch output	$U_N = 30 V_{DC}$ $U_M = 250 V_{AC}$					

Order code for "Output; input 2"; "Output; input 3" "Output; input 4"	Output type	Safety-related values					
		Output; input 2		Output; input 3		20 (+)	21 (-)
		24 (+)	25 (-)	22 (+)	23 (-)		
Option H	Relay output	$U_N = 30 V_{DC}$ $I_N = 100 mA_{DC}/500 mA_{AC}$ $U_M = 250 V_{AC}$					
Option I	Current input 4 to 20 mA	$U_N = 30 V_{DC}$ $U_M = 250 V_{AC}$					
Option J	Status input	$U_N = 30 V_{DC}$ $U_M = 250 V_{AC}$					

Low flow cut off The switch points for low flow cut off are user-selectable.

Galvanic isolation The outputs are galvanically isolated from one another and from earth (PE).

Protocol-specific data **HART**

Manufacturer ID	0x11
Device type ID	0x1160
HART protocol revision	7
Device description files (DTM, DD)	Information and files under: www.endress.com
HART load	Min. 250 Ω
System integration	Information on system integration: Operating Instructions . <ul style="list-style-type: none"> ▪ Measured variables via HART protocol ▪ Burst Mode functionality

Modbus RS485

Protocol	Modbus Applications Protocol Specification V1.1
Response times	<ul style="list-style-type: none"> ▪ Direct data access: typically 25 to 50 ms ▪ Auto-scan buffer (data range): typically 3 to 5 ms
Device type	Slave
Slave address range	1 to 247
Broadcast address range	0
Function codes	<ul style="list-style-type: none"> ▪ 03: Read holding register ▪ 04: Read input register ▪ 06: Write single registers ▪ 08: Diagnostics ▪ 16: Write multiple registers ▪ 23: Read/write multiple registers
Broadcast messages	Supported by the following function codes: <ul style="list-style-type: none"> ▪ 06: Write single registers ▪ 16: Write multiple registers ▪ 23: Read/write multiple registers
Supported baud rate	<ul style="list-style-type: none"> ▪ 1 200 BAUD ▪ 2 400 BAUD ▪ 4 800 BAUD ▪ 9 600 BAUD ▪ 19 200 BAUD ▪ 38 400 BAUD ▪ 57 600 BAUD ▪ 115 200 BAUD
Data transfer mode	<ul style="list-style-type: none"> ▪ ASCII ▪ RTU

Data access	Each device parameter can be accessed via Modbus RS485.  For Modbus register information
System integration	Information on system integration: Operating Instructions . <ul style="list-style-type: none"> ▪ Modbus RS485 information ▪ Function codes ▪ Register information ▪ Response time ▪ Modbus data map

Power supply

Terminal assignment

Transmitter: supply voltage, input/outputs

HART

Supply voltage		Input/output 1		Input/output 2		Input/output 3		Input/output 4	
1 (+)	2 (-)	26 (+)	27 (-)	24 (+)	25 (-)	22 (+)	23 (-)	20 (+)	21 (-)
Device-specific terminal assignment: adhesive label in terminal cover. →  17.									

Modbus RS485

Supply voltage		Input/output 1		Input/output 2		Input/output 3		Input/output 4	
1 (+)	2 (-)	26 (B)	27 (A)	24 (+)	25 (-)	22 (+)	23 (-)	20 (+)	21 (-)
Device-specific terminal assignment: adhesive label in terminal cover. →  17.									

Transmitter and sensor connection housing: connecting cable

The sensor and transmitter, which are mounted in separate locations, are interconnected by a connecting cable. The cable is connected via the sensor connection housing and the transmitter housing.

Terminal assignment and connection of the connecting cable:
Proline 500 – digital →  28

Device plugs available

 Device plugs may not be used in hazardous areas!

Device plug for connecting to the service interface:

Order code for "Accessory mounted"
option **NB**, adapter RJ45 M12 (service interface) →  27

Order code for "Accessory mounted", option **NB** "Adapter RJ45 M12 (service interface)"

Order code "Accessory mounted"	Cable entry/coupling →  28	
	Cable entry 2	Cable entry 3
NB	Plug M12 × 1	-

Pin assignment, device plug

Service interface

Order code for "Accessories mounted", option **NB**: Adapter RJ45 M12 (service interface)

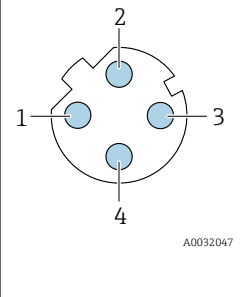
	Pin		Assignment	
	1	+	Tx	
	2	+	Rx	
	3	-	Tx	
	4	-	Rx	
Coding		Plug/socket		
D		Socket		



Recommended plug:

- Binder, series 763, part no. 99 3729 810 04
- Phoenix, part no. 1543223 SACC-M12MSD-4Q

Supply voltage

Order code for "Power supply"	Terminal voltage		Frequency range
Option D	DC 24 V	±20%	-
Option E	AC 100 to 240 V	-15 to +10%	50/60 Hz, ±4 Hz
Option I	DC 24 V	±20%	-
	AC 100 to 240 V	-15 to +10%	50/60 Hz, ±4 Hz

Power consumption

Transmitter

Max. 10 W (active power)

switch-on current	Max. 36 A (<5 ms) as per NAMUR Recommendation NE 21
--------------------------	---

Current consumption

Transmitter

- Max. 400 mA (24 V)
- Max. 200 mA (110 V, 50/60 Hz; 230 V, 50/60 Hz)

Power supply failure

- Totalizers stop at the last value measured.
- Depending on the device version, the configuration is retained in the device memory or in the pluggable data memory (HistoROM DAT).
- Error messages (incl. total operated hours) are stored.

Electrical connection

Connection of connecting cable: Proline 500 – digital

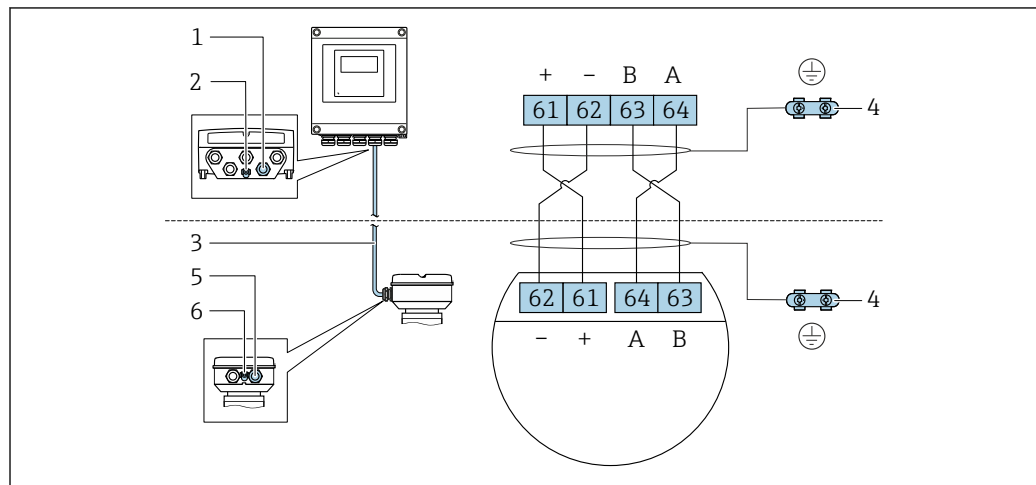

A0028198

- 1 Cable entry for cable on transmitter housing
- 2 Protective ground (PE)
- 3 Connecting cable ISEM communication
- 4 Grounding via ground connection; on device plug versions grounding is through the plug itself
- 5 Cable entry for cable or connection of device plug on sensor connection housing
- 6 Protective ground (PE)

Connecting the transmitter

- i** Terminal assignment → 26
- Device plug assignment → 27

Connecting the Proline 500 – digital transmitter

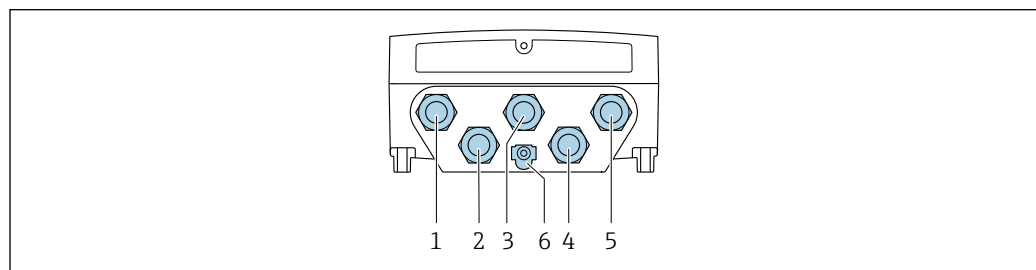

A0028200

- 1 Terminal connection for supply voltage
- 2 Terminal connection for signal transmission, input/output
- 3 Terminal connection for signal transmission, input/output
- 4 Terminal connection for connecting cable between sensor and transmitter
- 5 Terminal connection for signal transmission, input/output; optional: terminal connection for external WLAN antenna
- 6 Protective ground (PE)

- i** An adapter for RJ45 and the M12 connector is optionally available:
Order code for "Accessories", option **NB**: "Adapter RJ45 M12 (service interface)"

The adapter connects the service interface (CDI-RJ45) to an M12 connector mounted in the cable entry. Therefore the connection to the service interface can be established via an M12 connector without opening the device.

- i** Network connection (DHCP client) via service interface (CDI-RJ45) → 65

Connection examples

Current output 4 to 20 mA HART

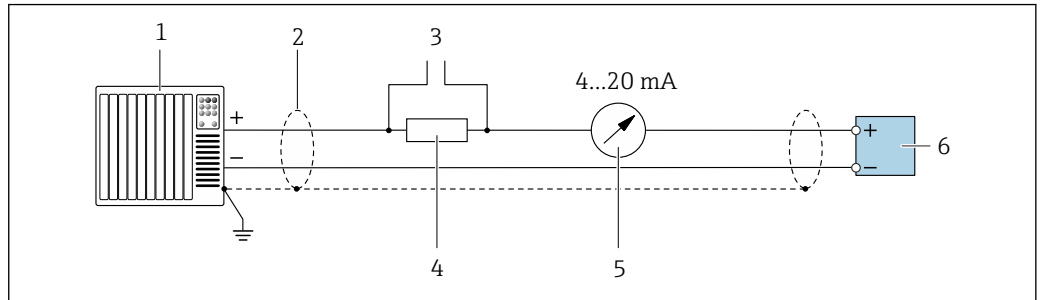

A0029055

2 Connection example for 4 to 20 mA HART current output (active)

- 1 Automation system with current input (e.g. PLC)
- 2 Cable shield provided at one end. The cable shield must be grounded at both ends to comply with EMC requirements; observe cable specifications → 33
- 3 Connection for HART operating devices → 64
- 4 Resistor for HART communication ($\geq 250 \Omega$); observe maximum load → 19
- 5 Analog display unit: observe maximum load → 19
- 6 Transmitter

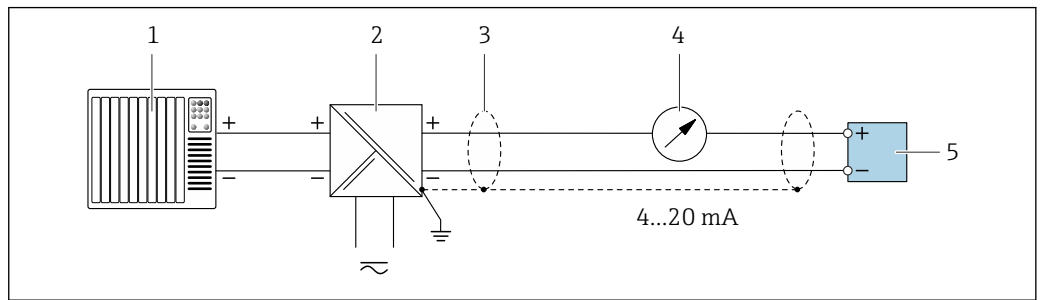

A0028762

3 Connection example for 4 to 20 mA HART current output (passive)

- 1 Automation system with current input (e.g. PLC)
- 2 Power supply
- 3 Cable shield provided at one end. The cable shield must be grounded at both ends to comply with EMC requirements; observe cable specifications → 33
- 4 Analog display unit: observe maximum load → 19
- 5 Transmitter

HART input

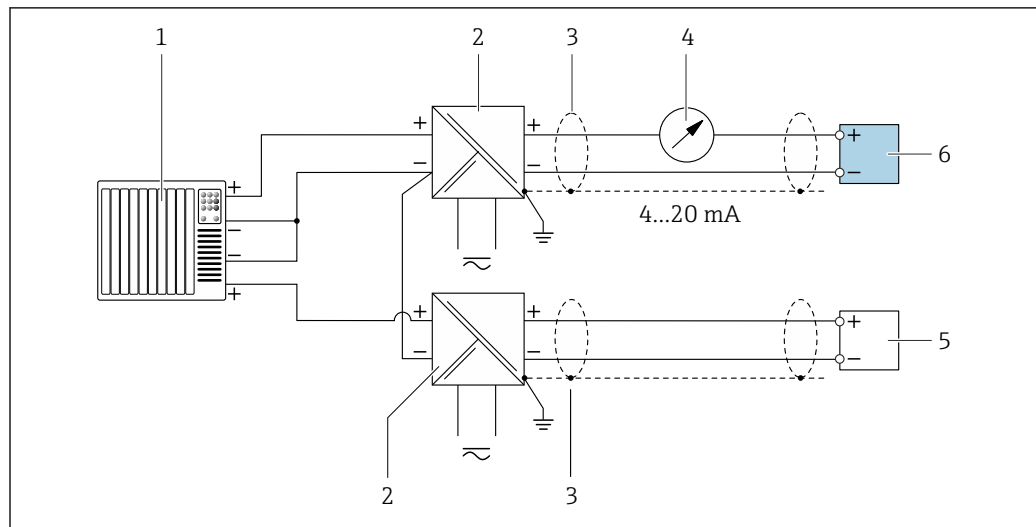

A0028763

4 Connection example for HART input with a common negative (passive)

- 1 Automation system with HART output (e.g. PLC)
- 2 Active barrier for power supply (e.g. RN221N)
- 3 Cable shield provided at one end. The cable shield must be grounded at both ends to comply with EMC requirements; observe cable specifications
- 4 Analog display unit: observe maximum load → 19
- 5 Pressure measuring device (e.g. Cerabar M, Cerabar S): see requirements
- 6 Transmitter

Modbus RS485

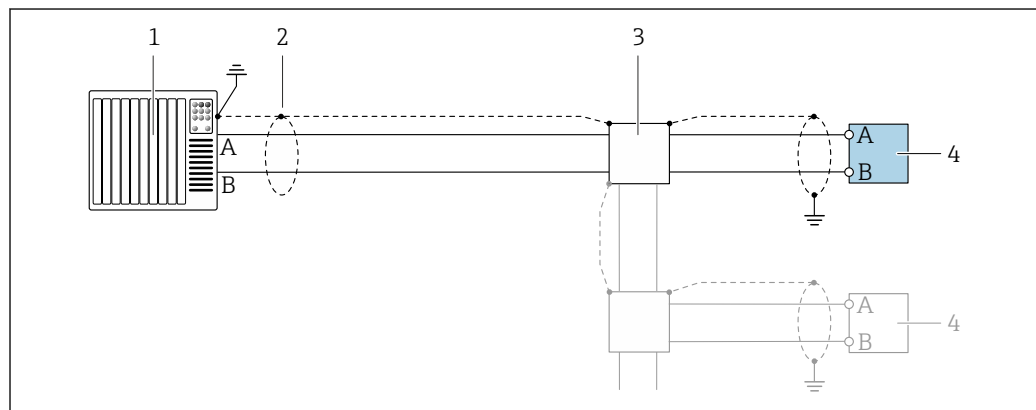

A0028765

5 Connection example for Modbus RS485, non-hazardous area and Zone 2; Class I, Division 2

- 1 Control system (e.g. PLC)
- 2 Cable shield provided at one end. The cable shield must be grounded at both ends to comply with EMC requirements; observe cable specifications
- 3 Distribution box
- 4 Transmitter

Current output 4-20 mA

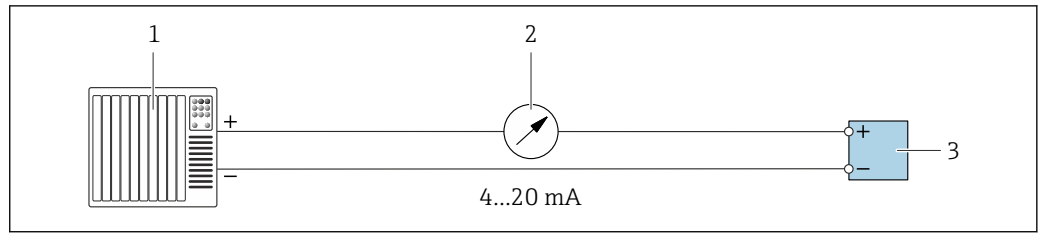

A0028758

6 Connection example for 4-20 mA current output (active)

- 1 Automation system with current input (e.g. PLC)
- 2 Analog display unit: observe maximum load → 19
- 3 Transmitter

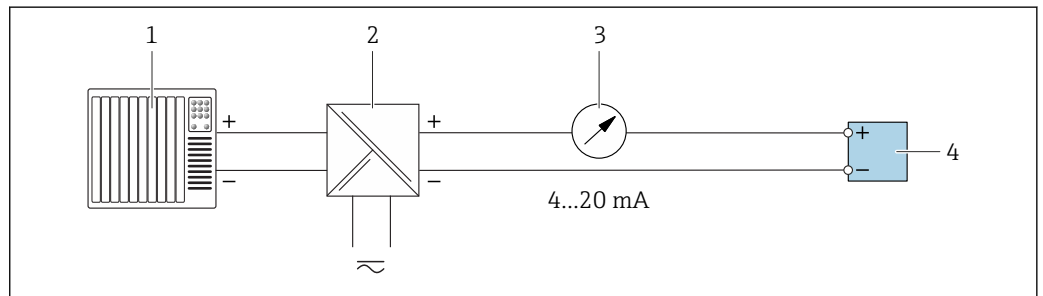

A0028759

7 Connection example for 4-20 mA current output (passive)

- 1 Automation system with current input (e.g. PLC)
- 2 Active barrier for power supply (e.g. RN221N)
- 3 Analog display unit: observe maximum load → 19
- 4 Transmitter

Pulse/frequency output

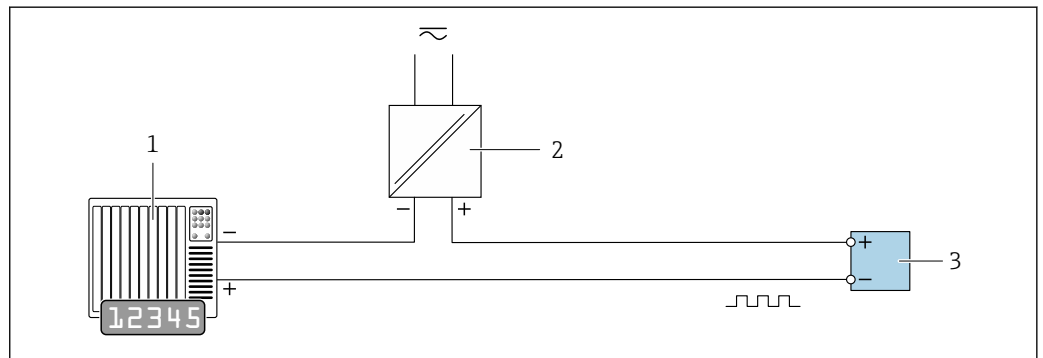

A0028761

8 Connection example for pulse/frequency output (passive)

- 1 Automation system with pulse/frequency input (e.g. PLC)
- 2 Power supply
- 3 Transmitter: Observe input values → 21

Switch output

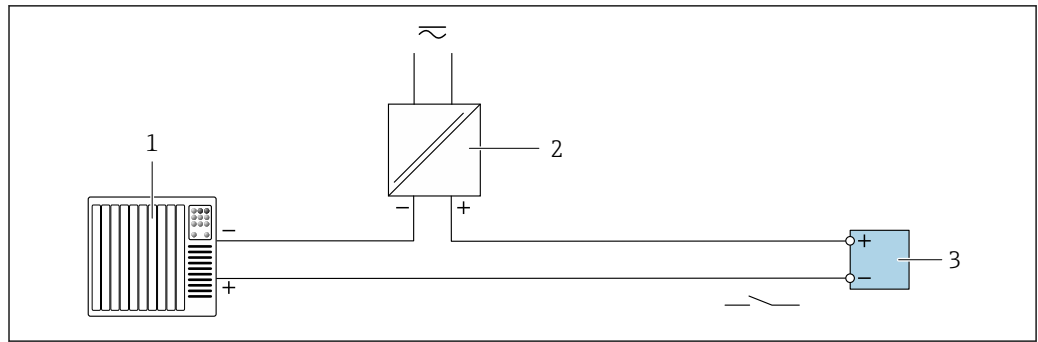

A0028760

9 Connection example for switch output (passive)

- 1 Automation system with switch input (e.g. PLC)
- 2 Power supply
- 3 Transmitter: Observe input values → 21

Relay output

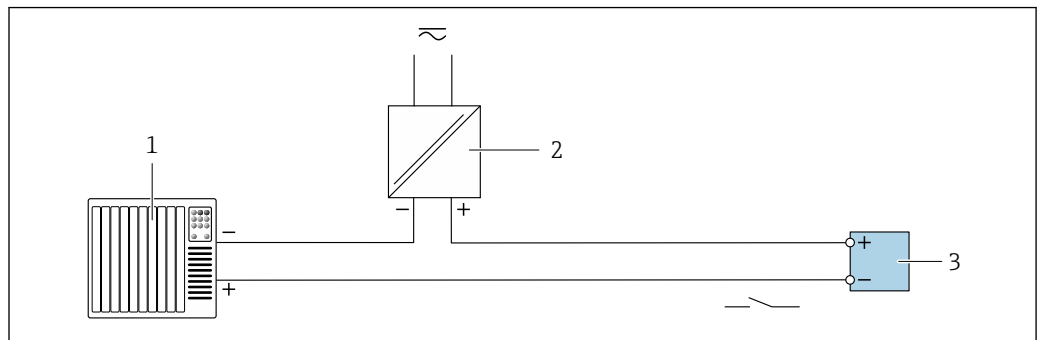

A0028760

10 Connection example for relay output (passive)

- 1 Automation system with relay input (e.g. PLC)
- 2 Power supply
- 3 Transmitter: Observe input values → 22

Current input

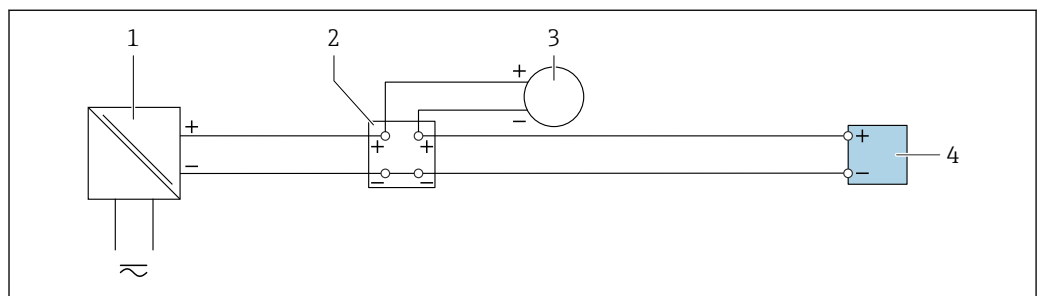

A0028915

11 Connection example for 4 to 20 mA current input

- 1 Power supply
- 2 Terminal box
- 3 External measuring device (to read in pressure or temperature, for instance)
- 4 Transmitter

Status input

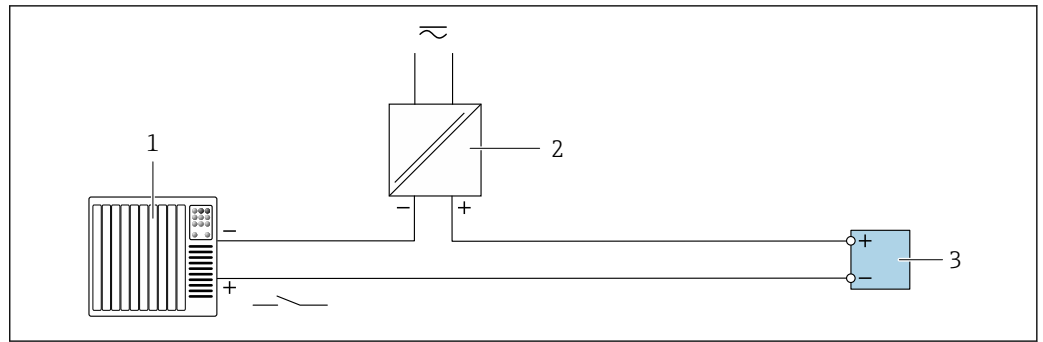

12 Connection example for status input

- 1 Automation system with status output (e.g. PLC)
- 2 Power supply
- 3 Transmitter

Terminals

Spring-loaded terminals: Suitable for strands and strands with ferrules.
 Conductor cross-section 0.2 to 2.5 mm² (24 to 12 AWG).

Cable entries

- Cable gland: M20 × 1.5 with cable Ø 6 to 12 mm (0.24 to 0.47 in)
- Thread for cable entry:
 - NPT ½"
 - G ½"
 - M20

Cable specification

Permitted temperature range

- The installation guidelines that apply in the country of installation must be observed.
- The cables must be suitable for the minimum and maximum temperatures to be expected.

Power supply cable (incl. conductor for the inner ground terminal)

Standard installation cable is sufficient.

Protective grounding cable for the outer ground terminal

Conductor cross-section ≤2.08 mm² (14 AWG)

Grounding impedance must be less than 2 Ω.

Signal cable

Current output 4 to 20 mA HART

A shielded cable is recommended. Observe grounding concept of the plant.

Modbus RS485

The EIA/TIA-485 standard specifies two types of cable (A and B) for the bus line which can be used for every transmission rate. Cable type A is recommended.

Cable type	A
Characteristic impedance	135 to 165 Ω at a measuring frequency of 3 to 20 MHz
Cable capacitance	< 30 pF/m
Wire cross-section	> 0.34 mm ² (22 AWG)
Cable type	Twisted pairs
Loop resistance	≤110 Ω/km
Signal damping	Max. 9 dB over the entire length of the cable cross-section
Shield	Copper braided shielding or braided shielding with foil shield. When grounding the cable shield, observe the grounding concept of the plant.

Current output 0/4 to 20 mA

Standard installation cable is sufficient.

Pulse/frequency/switch output

Standard installation cable is sufficient.

Relay output

Standard installation cable is sufficient.

Current input 0/4 to 20 mA

Standard installation cable is sufficient.

Status input

Standard installation cable is sufficient.

Choice of connecting cable between the transmitter and sensor

Depends on the type of transmitter and the installation zones

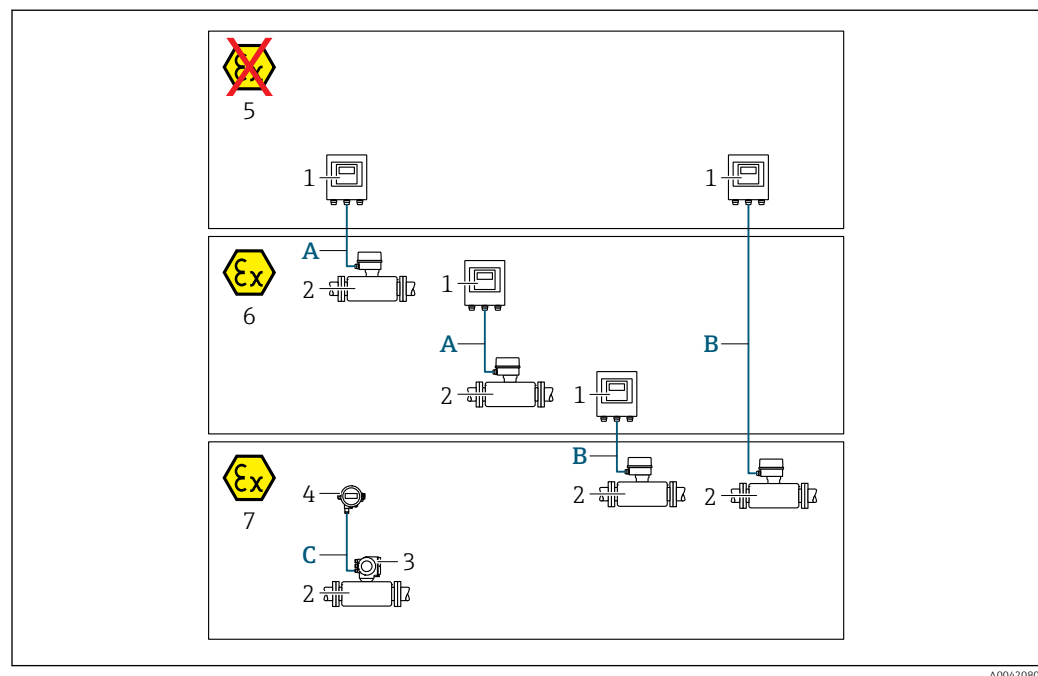

1 Proline 500 – digital transmitter

2 Sensor t-mass

3 Proline 300 transmitter

4 Remote display (DKX001)

5 Non-hazardous area

6 Hazardous area: Zone 2; Class I, Division 2

7 Hazardous area: Zone 1; Class I, Division 1

A Standard cable to 500 – digital transmitter

Transmitter installed in the non-hazardous area or hazardous area: Zone 2; Class I, Division 2 / sensor installed in the hazardous area: Zone 2; Class I, Division 2

B Standard cable to 500 – digital transmitter → 35

Transmitter installed in the hazardous area: Zone 2; Class I, Division 2 / sensor installed in the hazardous area: Zone 1; Class I, Division 1

C Standard cable to remote display

Transmitter 300 and remote display installed in the hazardous area: Zone 1; Class I, Division 1



For applications with operation in Zone 1; Class 1, Division 1, we recommend the use of the compact version with the remote display. In this case, the display of the Proline 300 transmitter is a blind version without local operation.

A: Connecting cable between sensor and transmitter: Proline 500 – digital

Standard cable

A standard cable with the following specifications can be used as the connecting cable.

Design	4 cores (2 pairs); uninsulated stranded CU wires; pair-stranded with common shield
Shielding	Tin-plated copper-braid, optical cover $\geq 85\%$
Loop resistance	Power supply line (+, -): maximum 10 Ω
Cable length	Maximum 300 m (1000 ft), see the following table.

Cross-section	Cable length [max.]
0.34 mm ² (AWG 22)	80 m (270 ft)
0.50 mm ² (AWG 20)	120 m (400 ft)
0.75 mm ² (AWG 18)	180 m (600 ft)
1.00 mm ² (AWG 17)	240 m (800 ft)
1.50 mm ² (AWG 15)	300 m (1000 ft)

Optionally available connecting cable

Design	2 × 2 × 0.34 mm ² (AWG 22) PVC cable ¹⁾ with common shield (2 pairs, uninsulated stranded CU wires; pair-stranded)
Flame resistance	According to DIN EN 60332-1-2
Oil-resistance	According to DIN EN 60811-2-1
Shielding	Tin-plated copper-braid, optical cover $\geq 85\%$
Operating temperature	When mounted in a fixed position: -50 to +105 °C (-58 to +221 °F); when cable can move freely: -25 to +105 °C (-13 to +221 °F)
Available cable length	Fixed: 20 m (65 ft); variable: up to maximum 50 m (164 ft)

1) UV radiation can impair the cable outer sheath. Protect the cable from direct sunshine where possible.

B: Connecting cable between sensor and transmitter: Proline 500 - digital

Standard cable

A standard cable with the following specifications can be used as the connecting cable.

Design	4, 6, 8 cores (2, 3, 4 pairs); uninsulated stranded CU wires; pair-stranded with common shield
Shielding	Tin-plated copper-braid, optical cover $\geq 85\%$
Capacitance C	Maximum 760 nF IIC, maximum 4.2 μ F IIB
Inductance L	Maximum 26 μ H IIC, maximum 104 μ H IIB
Inductance/resistance ratio (L/R)	Maximum 8.9 μ H/ Ω IIC, maximum 35.6 μ H/ Ω IIB (e.g. in accordance with IEC 60079-25)
Loop resistance	Power supply line (+, -): maximum 5 Ω
Cable length	Maximum 100 m (330 ft), see the following table.

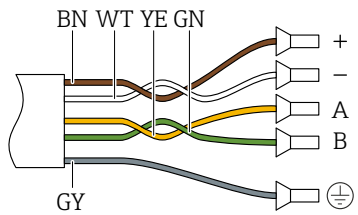
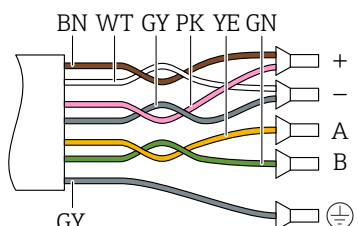
Cross-section	Cable length [max.]	Termination
2 x 2 x 0.50 mm ² (AWG 20)	50 m (165 ft)	2 x 2 x 0.50 mm ² (AWG 20)  <ul style="list-style-type: none"> ■ +, - = 0.5 mm² ■ A, B = 0.5 mm²
3 x 2 x 0.50 mm ² (AWG 20)	100 m (330 ft)	3 x 2 x 0.50 mm ² (AWG 20)  <ul style="list-style-type: none"> ■ +, - = 1.0 mm² ■ A, B = 0.5 mm²



Optionally available connecting cable

Connecting cable for	Zone 1; Class I, Division 1
Standard cable	2 × 2 × 0.5 mm ² (AWG 20) PVC cable ¹⁾ with common shield (2 pairs, pair-stranded)
Flame resistance	According to DIN EN 60332-1-2
Oil-resistance	According to DIN EN 60811-2-1
Shielding	Tin-plated copper-braid, optical cover ≥ 85 %
Operating temperature	When mounted in a fixed position: -50 to +105 °C (-58 to +221 °F); when cable can move freely: -25 to +105 °C (-13 to +221 °F)
Available cable length	Fixed: 20 m (65 ft); variable: up to maximum 50 m (165 ft)

1) UV radiation can impair the cable outer sheath. Protect the cable from direct sunshine where possible.

Performance characteristics

Reference operating conditions

- Error limits based on ISO 11631
 - Dry air with +20 to +30 °C (+68 to +86 °F) at 0.8 to 1.5 bar (12 to 22 psi)
 - Specifications as per calibration protocol
 - Accuracy based on accredited calibration rigs that are traced to ISO 17025.
-  To obtain measured errors, use the *Applicator* sizing tool →  76

Maximum measured error

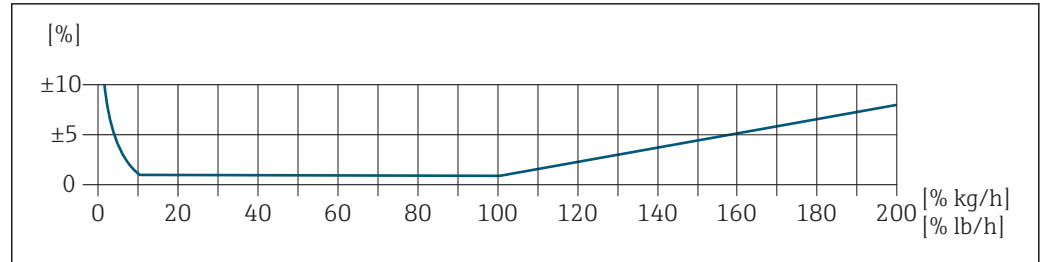

A0042739

Calibrated measuring range



The measuring accuracy is specified in relation to the mass flow and divided into two ranges:

- ±1.0 % of the current measured value for 100% to 10% of the calibrated measuring range (under reference operating conditions)
- ±0.10 % of the calibrated full scale value for 10% to 1% of the calibrated measuring range (under reference operating conditions)

The measuring device is calibrated and adjusted on an accredited and traceable calibration rig and its accuracy is certified in a calibration report ¹⁾ (5 control points).

Order code for "Calibration flow":

- Option G "Factory calibration": calibration report (5 control points)
- Option K "Traceable ISO/IEC17025": Swiss Calibration Services (SCS) calibration report (5 control points) which confirms traceability to the national calibration standard

 For information on calibrated measuring ranges and maximum full scale values →  12

Extended measuring range

The device has an extended measuring range that goes beyond the maximum calibrated value (100%). Here, the last measured values in the calibrated range are taken and then extrapolated. The end of the extrapolated range is only reached once the productive energy of the sensor is exceeded and/or the Mach number is greater than listed below.

Mach number	Order code
0.2	<ul style="list-style-type: none"> ▪ Order code for "Sensor version; sensor; measuring tube:", option SB "Bidirectional; stainless steel; stainless steel" ▪ Order code for "Sensor version; sensor; measuring tube:", option SC "Reverse flow detection; stainless steel; stainless steel"
0.4	<ul style="list-style-type: none"> ▪ Order code for "Sensor version; sensor; measuring tube:", option SA "Unidirectional; stainless steel; stainless steel" ▪ Order code for "Sensor version; sensor; measuring tube:", option HA "Unidirectional; Alloy; stainless steel"

The accuracy is specified in relation to the mass flow.

$\pm 1.0\% \pm (\text{current measured value in \%} - 100\%) \times 0.07$ for 100% to 200% of the calibrated measuring range (under reference operating conditions)

1) Two calibration reports for the order code for "Sensor version; sensor; measuring tube:", option SB "Bidirectional; stainless steel; stainless steel"

Accuracy of outputs

The outputs have the following base accuracy specifications.

Current output

Accuracy	$\pm 5 \mu\text{A}$
-----------------	---------------------

Pulse/frequency output

o.r. = of reading

Accuracy	Max. ± 50 ppm o.r. (over the entire ambient temperature range)
-----------------	--

Repeatability ± 0.25 % of the display value for velocities above 1.0 m/s (3.3 ft/s)

Response time Typically < 3 s for 63 % of a step change (in both directions)

Influence of ambient temperature**Current output**

Temperature coefficient	Max. $1 \mu\text{A}/^\circ\text{C}$
--------------------------------	-------------------------------------

Pulse/frequency output

Temperature coefficient	No additional effect. Included in accuracy.
--------------------------------	---

Influence of medium temperature

Air: 0.02 % per $^\circ\text{C}$ (0.036 % per $^\circ\text{F}$) of the process temperature change in relation to the reference temperature

Influence of medium pressure

Air: 0.3 % per bar (0.02 % per psi) of the process pressure change (from the set process pressure)



Installation

As a prerequisite for correct flow measurement, thermal measuring devices require a fully developed flow profile. For this reason, please pay attention to the following points and document sections when installing the device:

- Avoid flow disturbances, as the thermal measuring principle reacts sensitively to them.
- Give priority to dry gases.
- Take measures to avoid or remove condensation (e.g. condensation trap, thermal insulation etc.).

Orientation

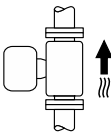
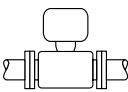
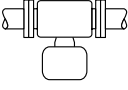
The direction of flow must match the direction of the arrow on the sensor. In the case of the bidirectional sensor, the arrow points in the positive direction.

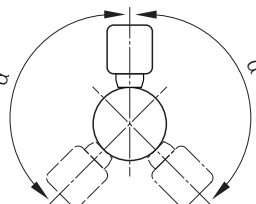
Orientation		Recommendation
Vertical orientation	 A0015591	✓ ¹⁾
Horizontal orientation, transmitter head up	 A0015589	✓✓
Horizontal orientation, transmitter head down	 A0015590	✓ ²⁾
Horizontal orientation, transmitter head at side	 A0015592	✓
Inclined orientation, transmitter head down	 A0015773	✓ ²⁾

- 1) In the case of saturated or impure gases, vertical orientation is preferred in order to minimize condensation or contamination. For bidirectional sensors, select horizontal orientation.
- 2) Select inclined orientation ($\alpha = \text{approx. } 135^\circ$) for very wet or water-saturated gas (e.g. digester gas, undried compressed air), or if deposits or condensate are constantly present.

Installation instructions

Install the measuring device in a parallel plane free of external mechanical stress.

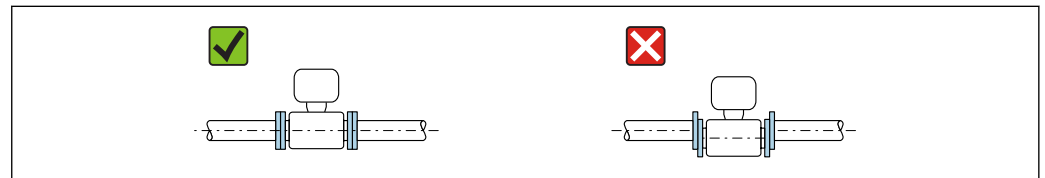

A0015895

Pipes

The measuring device must be professionally installed, and the following points must be observed:

- Weld pipes professionally.
- Use seals of the correct size.
- Align flanges and seals correctly.

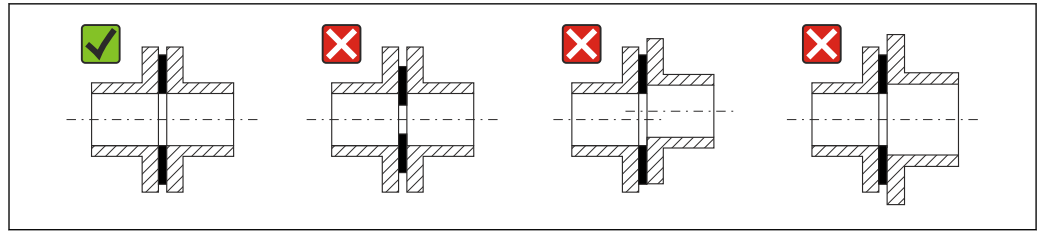

A0023496

- Following installation, the pipe must be free from dirt and particles in order to avoid damage to the sensors.
- For further information → ISO standard 14511.

Internal diameter

During the calibration, the device is adjusted with the following inlet pipes depending on the selected process connection. The corresponding internal diameters are listed in the following table:

SI units

DN [mm]	Inlet pipe internal diameter [mm]		
	DIN ¹⁾	Sch40 ²⁾	Sch80
15	17.3	15.7	13.9
25	28.5	26.7	24.3
40	43.1	40.9	38.1
50	54.5	52.6	49.2
65	70.3	62.7	59
80	83.7	78.1	73.7
100	107.1	102.4	97

- 1) Order code for "Process connection", option RAA "R thread EN10226-1 / ISO 7-1"
- 2) Order code for "Process connection", option NPT "MNPT thread, ASME"

US units

DN [in]	Inlet pipe internal diameter [in]		
	DIN ¹⁾	Sch40 ²⁾	Sch80
½	0.68	0.62	0.55
1	1.12	1.05	0.96
1 ½	1.7	1.61	1.5
2	2.15	2.07	1.94
2 ½	2.77	2.47	2.32
3	3.30	3.07	2.9
4	4.22	4.03	3.82

- 1) Order code for "Process connection", option RAA "R thread EN10226-1 / ISO 7-1"
- 2) Order code for "Process connection", option NPT "MNPT thread, ASME"

To ensure maximum measuring performance, choose an inlet pipe with an almost identical internal diameter.

Inlet and outlet runs

A fully developed flow profile is a prerequisite for optimum thermal flow measurement.

To achieve the best possible measuring performance, observe the following inlet and outlet runs at the very minimum.

- In the case of bidirectional sensors, also observe the recommended inlet run in the opposite direction.
- If several flow disturbances are present, use flow conditioners.
- Use flow conditioners if it is not possible to observe the required inlet runs.
- In the case of control valves, the interference influence depends on the valve type and opening degree. The recommended inlet run for control valves is $50 \times \text{DN}$.
- In the case of very light gases (helium, hydrogen), the recommended inlet run must be doubled.

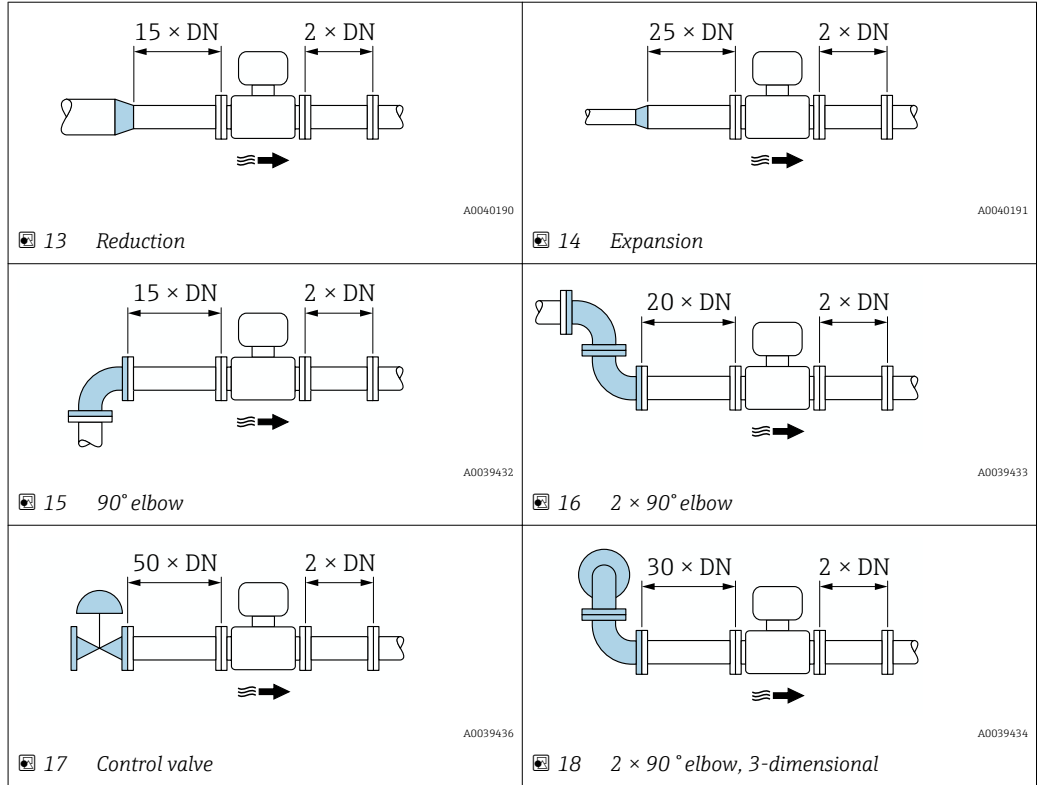

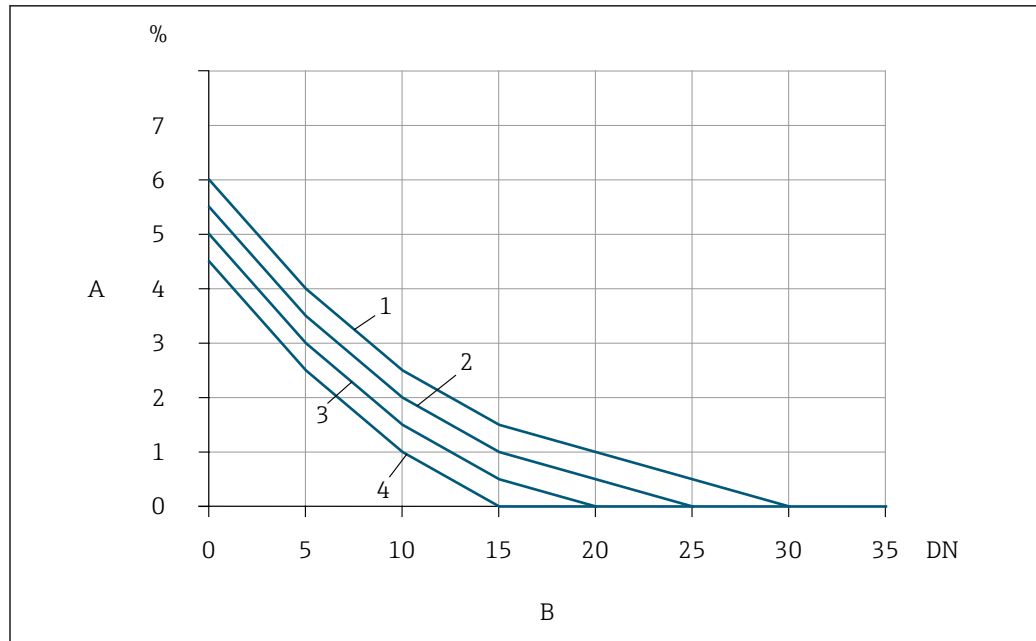

A0039507

19 The additional measured error to be expected without flow conditioners depending on the type of interference and inlet run

- A Additional measured error (%)
 B Inlet run (DN)
 1 $2 \times 90^\circ$ elbow, 3-dimensional
 2 Expansion
 3 $2 \times 90^\circ$ elbow
 4 Reduction or 90° elbow

Flow conditioner

Use flow conditioners if it is not possible to observe the required inlet runs. Flow conditioners improve the flow profile and therefore reduce the necessary inlet runs.

i The flow conditioner is permanently integrated in the flange and must be ordered with the device. It is not possible to retrofit a flow conditioner.

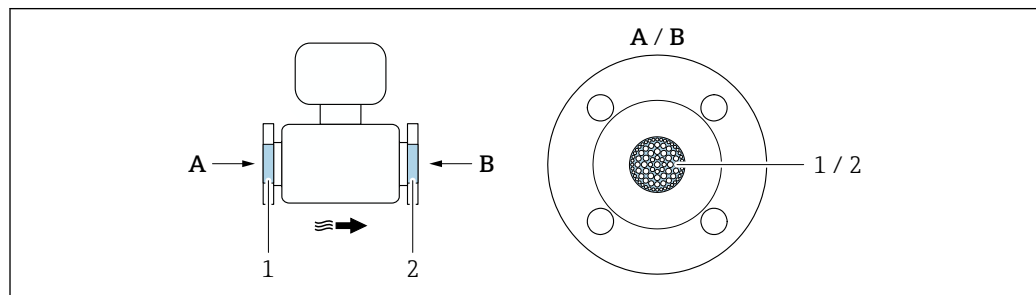

A0039539

- 1 Flow conditioner for unidirectional, bidirectional version and reverse flow detection
 2 Optional, additional flow conditioner for bidirectional version

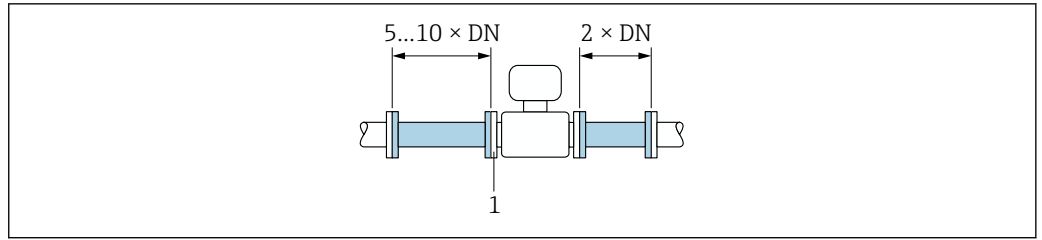

A0039425

20 Recommended inlet and outlet runs when using a flow conditioner

1 Flow conditioner

i In the case of bidirectional sensors, also observe the inlet run in the opposite direction.

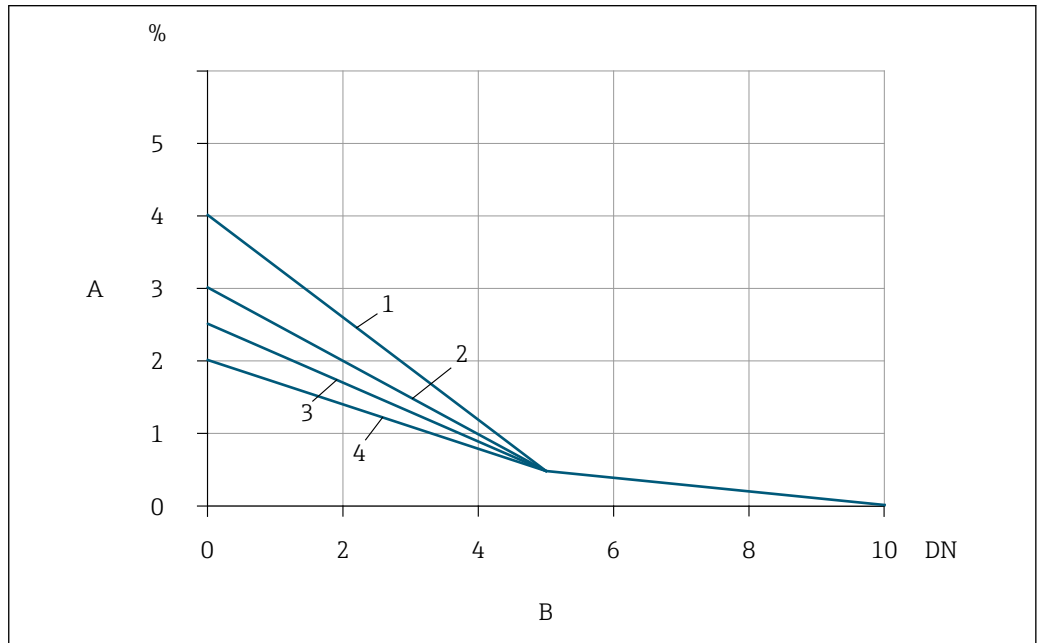

A0039508

21 The additional measured error to be expected with flow conditioners depending on the type of interference and inlet run

- A Additional measured error (%)
- B Inlet runs (DN)
- 1 2 x 90° elbow, 3-dimensional
- 2 Expansion
- 3 2 x 90° elbow
- 4 Reduction or 90° elbow

Outlet runs with pressure measuring points

Install the pressure measuring point downstream of the measuring system. This prevents the pressure transmitter from potentially affecting the flow in the measuring point.

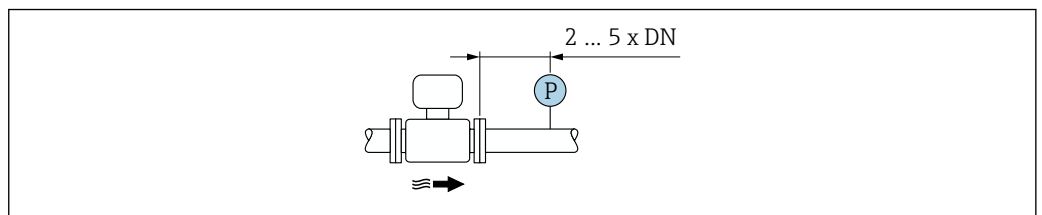

A0039438

22 Installation of a pressure measuring point (P = pressure transmitter)

Mounting the transmitter housing

Proline 500 – digital transmitter

Post mounting

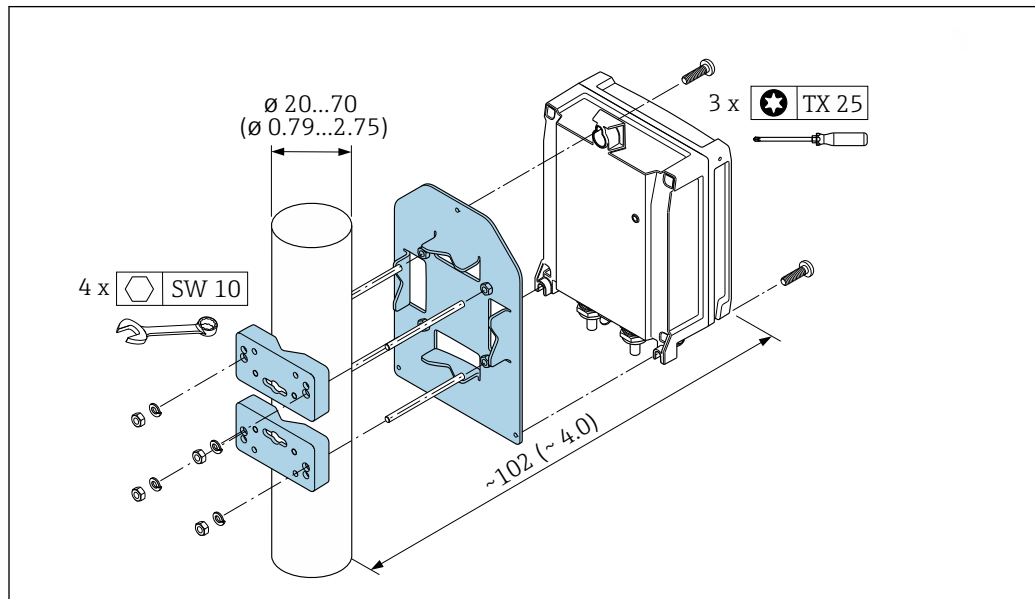

A0029051

23 Engineering unit mm (in)

Wall mounting

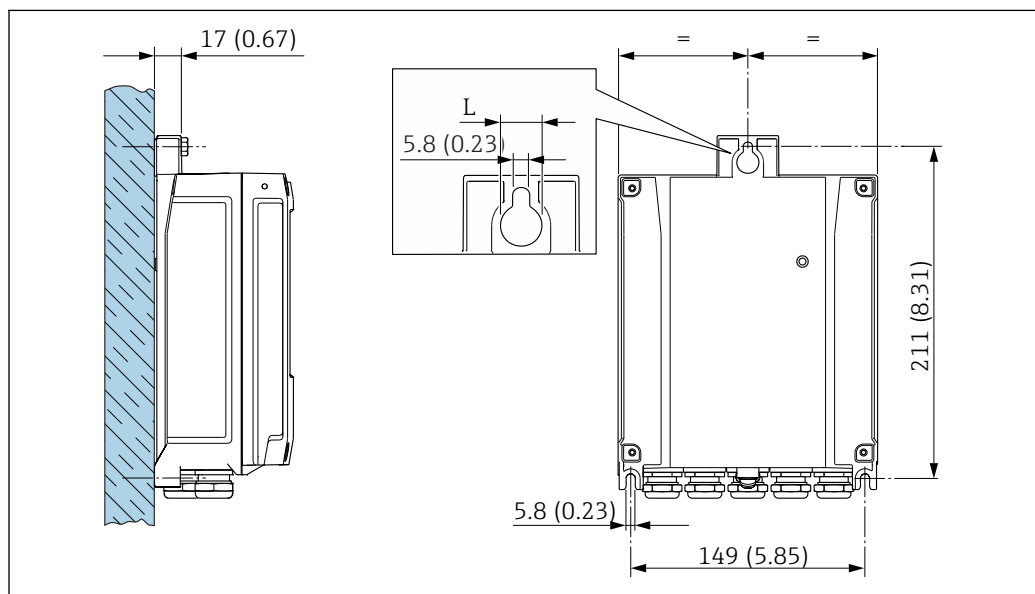

A0029054

24 Engineering unit mm (in)

L Depends on order code for "Transmitter housing"

Order code for "Transmitter housing"

- Option A, aluminum coated: L = 14 mm (0.55 in)
- Option D, polycarbonate: L = 13 mm (0.51 in)

Environment

Ambient temperature range	Measuring device	<ul style="list-style-type: none"> ■ -40 to +60 °C (-40 to +140 °F) ■ Order code for "Test, certificate", option JP: -50 to +60 °C (-58 to +140 °F)
	Readability of the local display	-20 to +60 °C (-4 to +140 °F) The readability of the display may be impaired at temperatures outside the temperature range.

- ▶ If operating outdoors:
Avoid direct sunlight, particularly in warm climatic regions.

 You can order a weather protection cover from Endress+Hauser →  75.

Storage temperature -50 to +80 °C (-58 to +176 °F), preferably at +20 °C (+68 °F)

Atmosphere If a plastic transmitter housing is permanently exposed to certain steam and air mixtures, this can damage the housing.

 In cases of doubt, please contact the Sales Center.

Degree of protection

Transmitter

- As standard: IP66/67, type 4X enclosure
- When housing is open: IP20, type 1 enclosure
- Display module: IP20, type 1 enclosure

Sensor

- As standard: IP66/67, type 4X enclosure
- With the order code for "Sensor option", IP68 can also be ordered:
Option CC "IP68, Type 6P, cust-potted"

External WLAN antenna
IP67

Vibration- and shock-resistance

Vibration sinusoidal, in accordance with IEC 60068-2-6

Sensor

- 2 to 8.4 Hz, 3.5 mm peak
- 8.4 to 2 000 Hz, 1 g peak

Transmitter

- 2 to 8.4 Hz, 7.5 mm peak
- 8.4 to 2 000 Hz, 2 g peak

Vibration broad-band random, according to IEC 60068-2-64

Sensor

- 10 to 200 Hz, 0.003 g²/Hz
- 200 to 2 000 Hz, 0.001 g²/Hz
- Total: 1.54 g rms

Transmitter

- 10 to 200 Hz, 0.01 g²/Hz
- 200 to 2 000 Hz, 0.003 g²/Hz
- Total: 2.70 g rms

Shock half-sine, according to IEC 60068-2-27

- Sensor
6 ms 30 g
- Transmitter
6 ms 50 g

Rough handling shocks according to IEC 60068-2-31

Interior cleaning

Suitable for cleaning-in-place (CIP) and sterilization-in-place (SIP).

Manufacturer options for delivery of parts

- Oil- and grease-free wetted parts, no declaration. Order code for "Service", option HA.
- Oil- and grease-free wetted parts as per IEC/TR 60877-2.0 and BOC 50000810-4, with declaration. Order code for "Service", option HB. The plant operator must ensure that the measuring device meets the requirements of the operator's oxygen application.

Electromagnetic compatibility (EMC)

As per IEC/EN 61326 and NAMUR Recommendation 21 (NE 21)



Details are provided in the Declaration of Conformity.

Process

Medium temperature range Sensor
-40 to +180 °C (-40 to +356 °F)

Medium pressure range Minimum 0.5 bar absolute. Maximum permitted medium pressure → 47

Pressure-temperature ratings The following pressure/temperature diagrams apply to all pressure-bearing parts of the device and not just the process connection. The diagrams show the maximum permissible medium pressure depending on the specific medium temperature.

Flange connection according to EN 1092-1 (DIN 2501/DIN 2512N)

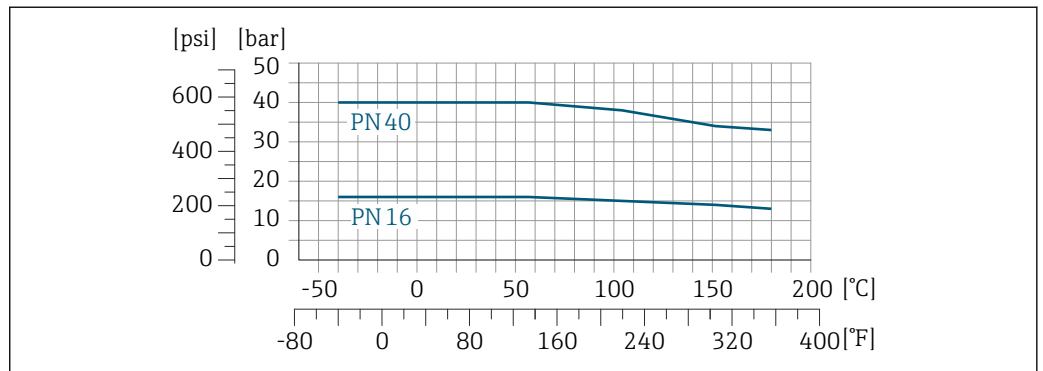

25 With flange material 1.4404/F316L/F316

Flange connection according to JIS B2220

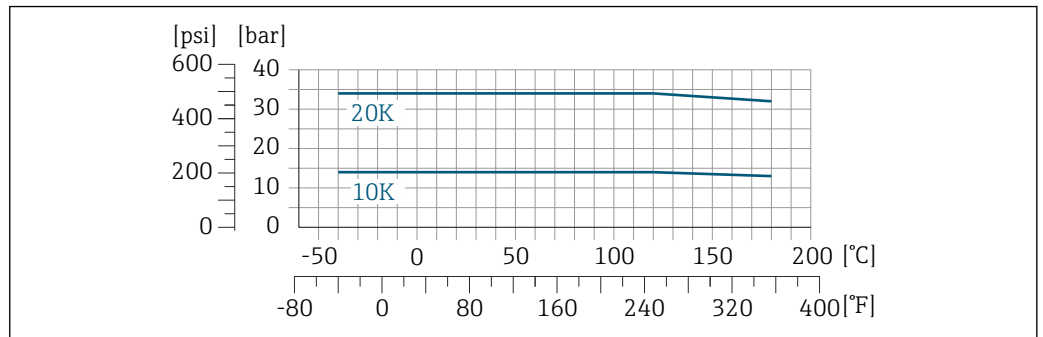

26 With flange material 1.4404/F316L/F316

Flange connection as per ASME B16.5

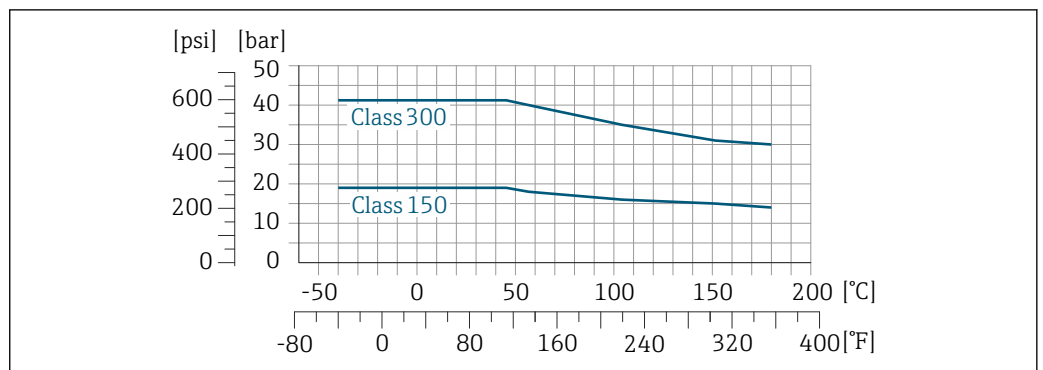

27 With flange material 1.4404/F316L/F316

Flow limit

 Measuring range →  12

The maximum flow depends on the gas type and the pipe nominal diameter used. The end of the measuring range is reached when the Mach number listed below is reached.

Mach number	Order code
0.2	<ul style="list-style-type: none"> ▪ Order code for "Sensor version; sensor; measuring tube.", option SB "Bidirectional; stainless steel; stainless steel" ▪ Order code for "Sensor version; sensor; measuring tube.", option SC "Reverse flow detection; stainless steel; stainless steel"
0.4	<ul style="list-style-type: none"> ▪ Order code for "Sensor version; sensor; measuring tube.", option SA "Unidirectional; stainless steel; stainless steel" ▪ Order code for "Sensor version; sensor; measuring tube.", option HA "Unidirectional; Alloy; stainless steel"

 Use the Applicator to size the device.

Pressure loss

 Use the Applicator for precise calculations.

Thermal insulation

In the case of some fluids, it is important to keep the heat radiated from the sensor to the transmitter to a low level. A wide range of materials can be used for the required insulation.

If the gas is very wet or saturated with water (e.g. digester gas), the pipe and the sensor housing should be insulated, and heated where necessary, to prevent water droplets condensing on the sensing element.

NOTICE**Electronics overheating on account of thermal insulation!**

- ▶ Recommended orientation: horizontal orientation, sensor connection housing pointing downwards.
- ▶ Do not insulate the sensor connection housing.
- ▶ Maximum permissible temperature at the lower end of the sensor connection housing: 80 °C (176 °F)
- ▶ Thermal insulation with extended neck free: We recommend that you do not insulate the extended neck in order to ensure optimum dissipation of heat.

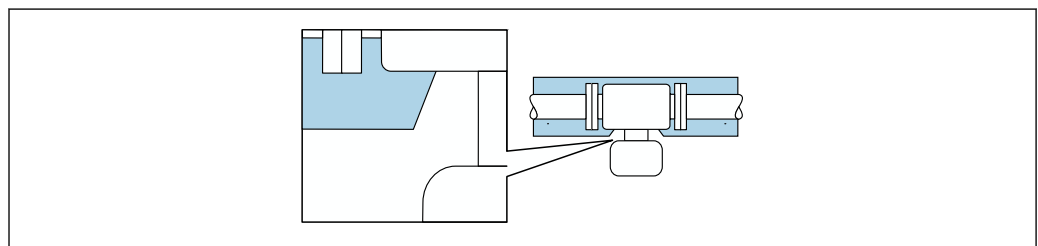

 28 Thermal insulation with extended neck free

Heating

Some fluids require suitable measures to avoid loss of heat at the sensor.

Heating options

- Electrical heating, e.g. with electric band heaters
- Via pipes carrying hot water or steam

NOTICE

Electronics overheating on account of thermal insulation!

- ▶ Recommended orientation: horizontal orientation, sensor connection housing pointing downwards.
- ▶ Do not insulate the sensor connection housing.
- ▶ Maximum permissible temperature at the lower end of the sensor connection housing: 80 °C (176 °F)
- ▶ Thermal insulation with extended neck free: We recommend that you do not insulate the extended neck in order to ensure optimum dissipation of heat.

NOTICE

Danger of overheating when heating

- ▶ Ensure that the temperature at the lower end of the transmitter housing does not exceed 80 °C (176 °F).
- ▶ Ensure that sufficient convection takes place at the transmitter neck.
- ▶ When using in potentially explosive atmospheres, observe the information in the device-specific Ex documentation. For detailed information on the temperature tables, see the separate document entitled "Safety Instructions" (XA) for the device.
- ▶ Ensure that a sufficiently large area of the transmitter neck remains exposed. The uncovered part serves as a radiator and protects the electronics from overheating and excessive cooling.

Mechanical construction

Dimensions in SI units

Housing of Proline 500 – digital transmitter

Non-hazardous area or hazardous area: Zone 2; Class I, Division 2

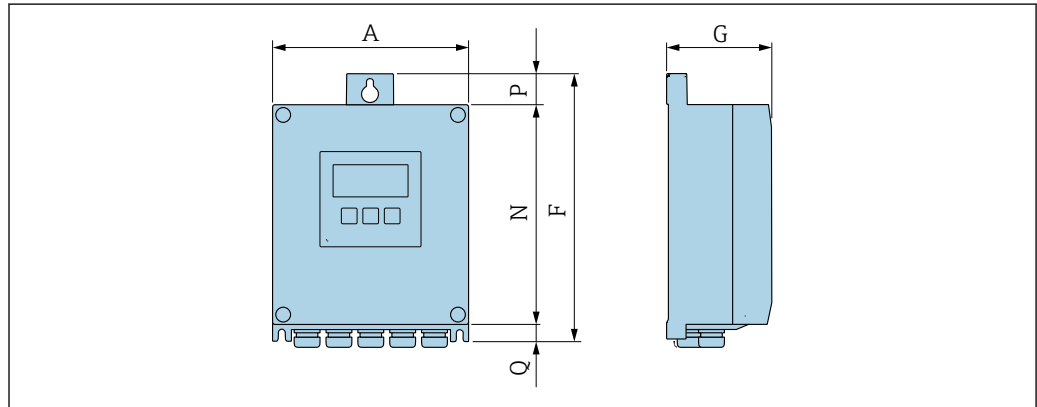

A0033789

Order code for "Transmitter housing", option A "Aluminum, coated" and order code for "Integrated ISEM electronics", option A "Sensor"

A [mm]	F [mm]	G [mm]	N [mm]	P [mm]	Q [mm]
167	232	89	187	24	21

Order code for "Transmitter housing", option D "Polycarbonate" and order code for "Integrated ISEM electronics", option A "Sensor"

A [mm]	F [mm]	G [mm]	N [mm]	P [mm]	Q [mm]
177	234	89	197	17	22

Sensor with connection housing

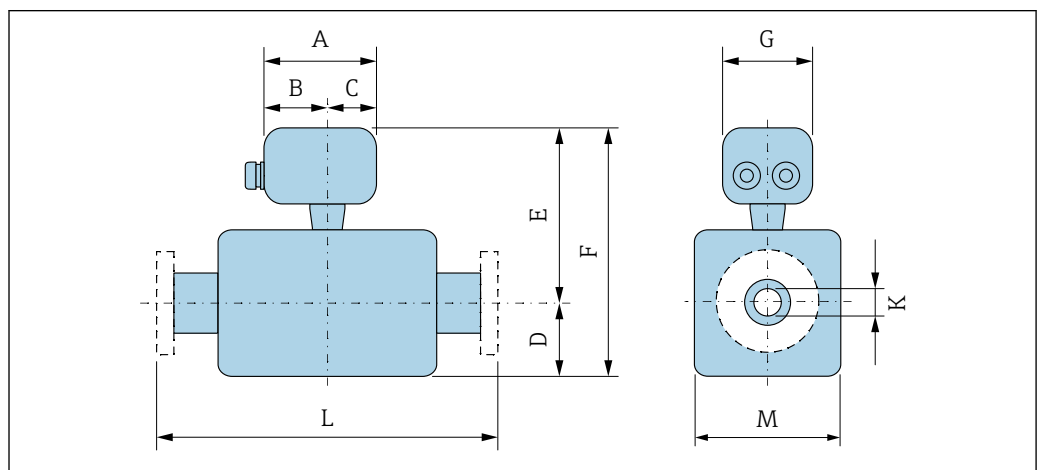

A0033784

L Installed length with specific process connection → 51

Order code for "Sensor connection housing", option A "Aluminum, coated"

A ¹⁾ [mm]	B ¹⁾ [mm]	C [mm]	G [mm]
148	94	54	136

1) Depending on the cable gland used: values up to + 30 mm

Order code for "Sensor connection housing", option L "Cast, stainless"

A ¹⁾ [mm]	B ¹⁾ [mm]	C [mm]	G [mm]
145	86	59	136

1) Depending on the cable gland used: values up to + 30 mm

Order code for "Sensor connection housing", option A "Aluminum, coated"

DN [mm]	D [mm]	E [mm]	F [mm]	M [mm]	K [mm]	L ¹⁾ [mm]
15	13	242	255	36	14.2	245
25	17	242	259	36	24.3	245
40	24	247	271	48	38.1	320
50	30	244	274	60	49.2	400
65	47	252	289	73	62.7	520
80	41	254	295	82.5	72.5	640
100	54	259	313	108	96	800

1) With order code for "Sensor connection housing", option L "Cast, stainless" + 4 mm

Flange connections

Welding neck flange EN 1092-1-B1, ASME B16.5, JIS B2220

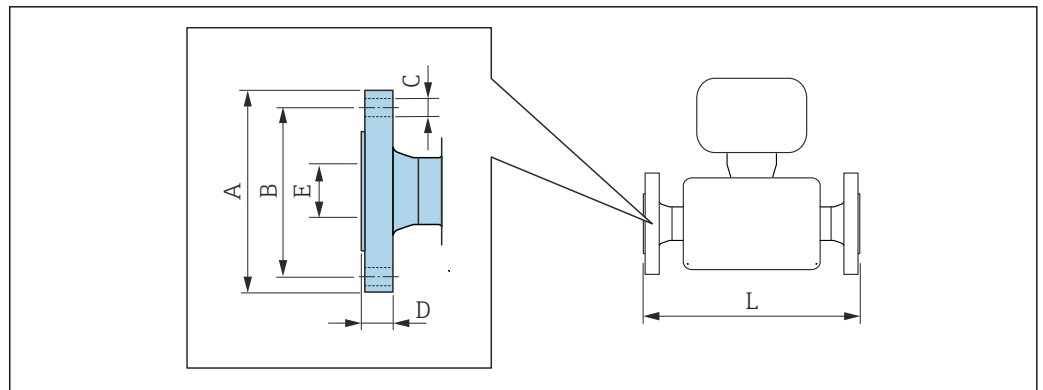

A0015621

i Length tolerance for dimension L in mm:
+1.5 / -2.0

Flange according to EN 1092-1-B1: PN 16 1.4404 (F316/F316L): order code for "Process connection", option D1S						
DN [mm]	A [mm]	B [mm]	C [mm]	D [mm]	E [mm]	L [mm]
100	220	180	8 × Ø18	20	97.0	800
Surface roughness (flange): EN 1092-1-B1, Ra 3.2 to 12.5 µm						

Flange according to EN 1092-1-B1: PN 40 1.4404 (F316/F316L): order code for "Process connection", option D2S						
DN [mm]	A [mm]	B [mm]	C [mm]	D [mm]	E [mm]	L [mm]
15	95	65	4 × Ø 14	16	13.9	245
25	115	85	4 × Ø 14	18	24.3	245
40	150	110	4 × Ø 18	18	38.1	320
50	165	125	4 × Ø 18	20	49.2	400
65	185	145	8 × Ø18	22	62.7	520
80	200	160	8 × Ø18	24	73.7	640
100	235	190	8 × Ø22	24	97	800
Surface roughness (flange): EN 1092-1-B1, Ra 3.2 to 12.5 µm						

Flange according to ASME B16.5: Class 150 RF, Schedule 40 and 80 1.4404 (F316/F316L): order code for "Process connection", option AAS 1.4404 (F316/F316L): order code for "Process connection", option AFS						
DN [mm]	A [mm]	B [mm]	C [mm]	D [mm]	E [mm]	L [mm]
15	88.9	60.5	4 × Ø 15.7	11.2	13.9	245
25	108	79.2	4 × Ø 15.7	15.7	24.3	245
40	127	98.6	4 × Ø 15.7	17.5	38.1	320
50	152.4	120.7	4 × Ø 19.1	19.1	49.2	400
65	180	139.7	4 × Ø 19.1	19.1	62.7	520
80	190.5	152.4	4 × Ø 19.1	23.9	73.7	640
100	228.6	190.5	8 × Ø19.1	24.5	97	800
Surface roughness (flange): ASME B16.5 "raised face", Ra 3.2 to 6.3 µm						

Flange according to ASME B16.5: Class 300 RF, Schedule 40 and 80 1.4404 (F316/F316L): order code for "Process connection", option ABS 1.4404 (F316/F316L): order code for "Process connection", option AGS						
DN [mm]	A [mm]	B [mm]	C [mm]	D [mm]	E [mm]	L [mm]
15	95.2	66.5	4 × Ø 15.7	14.2	13.9	245
25	124	88.9	4 × Ø 19.1	19.1	24.3	245
40	155.4	114.3	4 × Ø 22.4	20.6	38.1	320
50	165.1	127.0	8 × Ø19.1	22.4	49.2	400
65	190	149.2	8 × Ø22.4	25.9	62.7	520
80	209.6	168.1	8 × Ø22.4	28.4	73.7	640
100	254.0	200.2	8 × Ø22.4	31.8	97	800
Surface roughness (flange): ASME B16.5 "raised face", Ra 3.2 to 6.3 µm						

Flange according to JIS B2220 RF: 10K, Schedule 40 and 80						
1.4404 (F316/F316L): order code for "Process connection", option NDS						
1.4404 (F316/F316L): order code for "Process connection", option NFS						
DN [mm]	A [mm]	B [mm]	C [mm]	D [mm]	E [mm]	L [mm]
50	155	120	4 × Ø 19	16	49.2	400
65	175	140	4 × Ø 19	18	62.7	520
80	185	150	8 × Ø 19	20	73.7	640
100	210	175	8 × Ø 19	20	97	800

Surface roughness (flange): JIS B2220 "raised face", Ra 3.2 to 6.3 µm

Flange according to JIS B2220 RF: 20K, Schedule 40 and 80						
1.4404 (F316/F316L): order code for "Process connection", option NES						
1.4404 (F316/F316L): order code for "Process connection", option NGS						
DN [mm]	A [mm]	B [mm]	C [mm]	D [mm]	E [mm]	L [mm]
15	95	70	4 × Ø 15	14	13.9	245
25	125	90	4 × Ø 19	16	24.3	245
40	140	105	4 × Ø 19	18	38.1	320
50	155	120	8 × Ø 19	18	49.2	400
65	175	140	8 × Ø 19	20	62.7	520
80	200	160	8 × Ø 19	22	73.7	640
100	225	185	8 × Ø 19	24	97	800

Surface roughness (flange): JIS B2220 "raised face", Ra 3.2 to 6.3 µm

Threaded connections

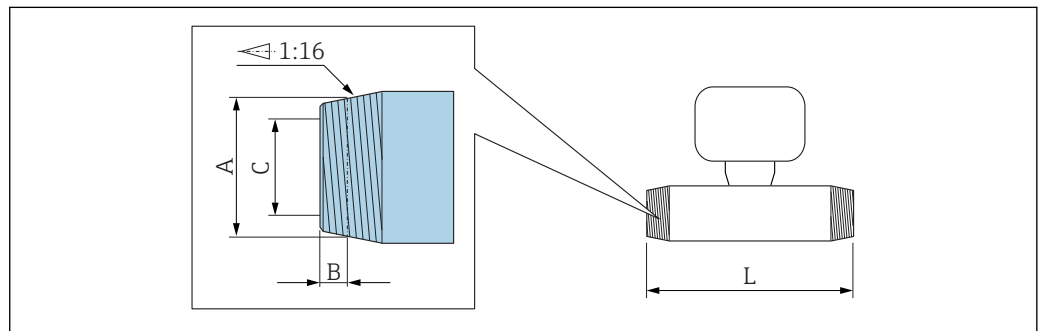

A0039448

R external thread as per EN 10226-1, ISO 7-1			
Order code for "Process connection", option RAA			
DN [mm]	A [in]	B [mm]	C [mm]
15	R ½	8.2	13.9
25	R 1	10.4	24.3
40	R 1½	12.7	38.1
50	R 2	15.9	49.2
65	R 2½	17.5	62.7
80	R 3	20.6	72.5
100	R 4	25.4	96.0

NPT external thread as per ASME B1.20.1 Order code for "Process connection", option NPT			
DN [mm]	A [in]	B [mm]	C [mm]
15	½ NPT	8.1	15.8
25	1 NPT	10.2	26.7
40	1½ NPT	10.7	40.9
50	2 NPT	11.1	52.5
65	2½ NPT	17.3	62.7
80	3 NPT	19.5	72.5
100	4 NPT	21.4	96.0

Accessories

Protective cover

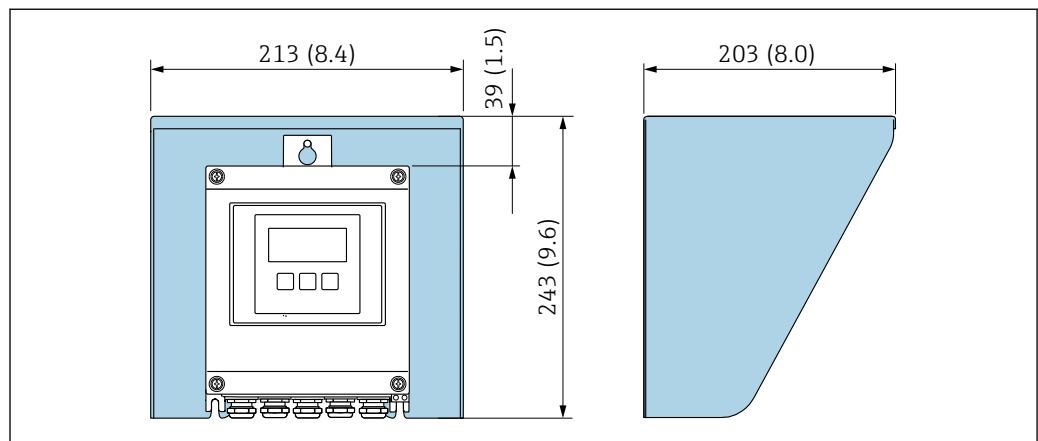

A0029552

29 Protective cover for Proline 500 – digital; engineering unit mm (in)

External WLAN antenna

Proline 500 – digital

External WLAN antenna mounted on device

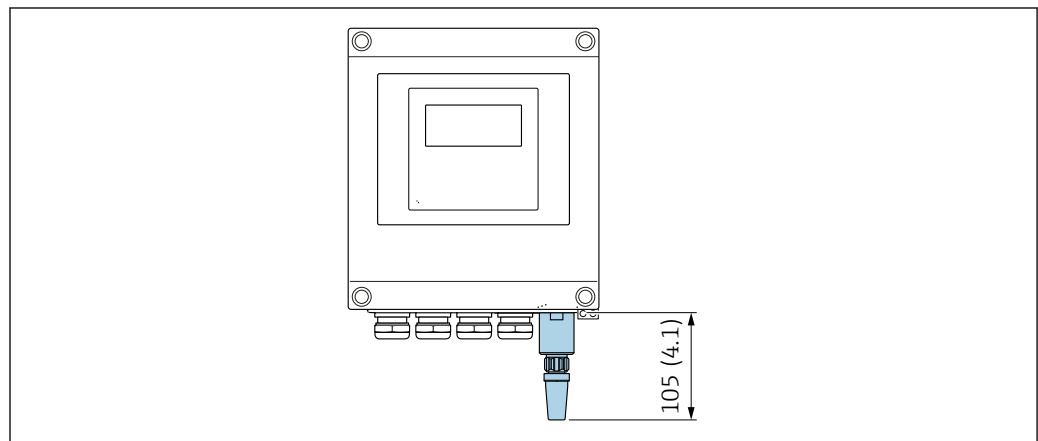

A0033607

30 Engineering unit mm (in)

External WLAN antenna mounted with cable

The external WLAN antenna can be mounted separately from the transmitter if the transmission/reception conditions at the transmitter mounting location are poor.

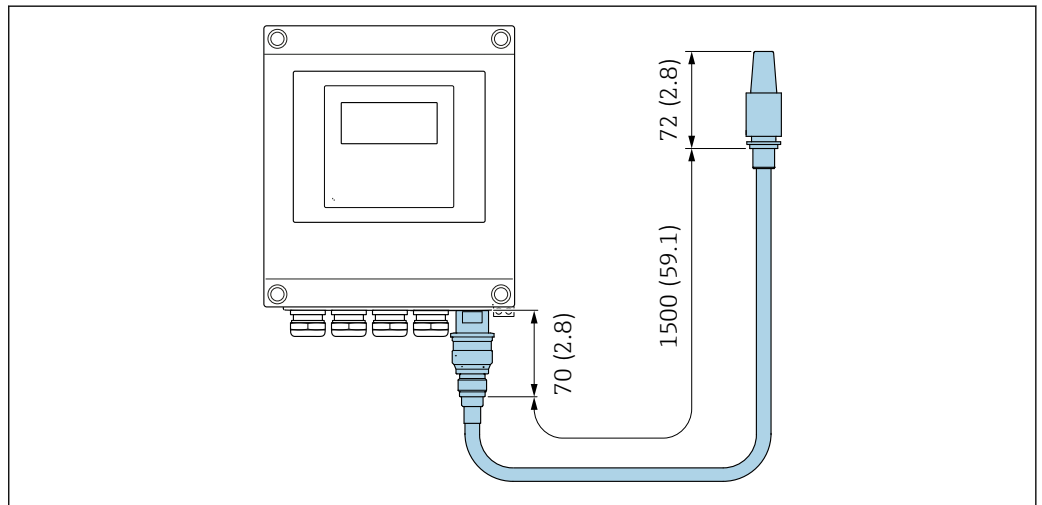

A0033606

31 Engineering unit mm (in)

Dimensions in US units

Housing of Proline 500 – digital transmitter

Non-hazardous area or hazardous area: Zone 2; Class I, Division 2

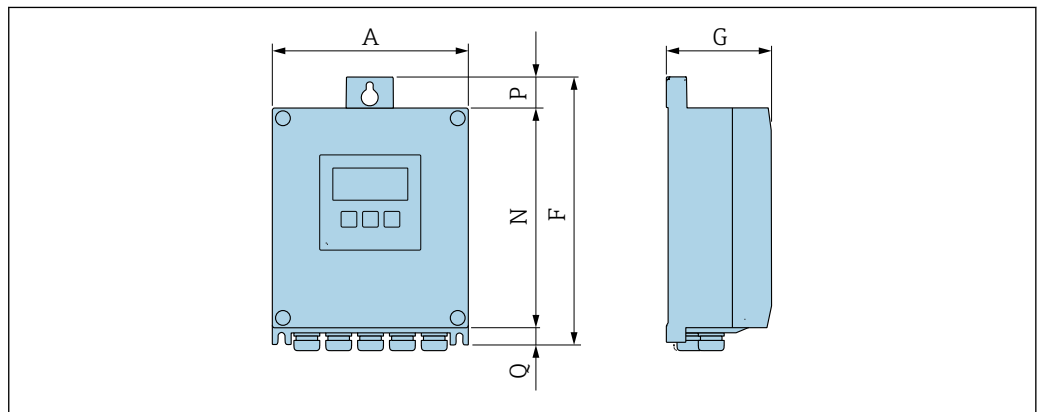

A0033789

Order code for "Transmitter housing", option A "Aluminum, coated" and order code for "Integrated ISEM electronics", option A "Sensor"

A [in]	F [in]	G [in]	N [in]	P [in]	Q [in]
6.57	9.13	3.50	7.36	0.94	0.83

Order code for "Transmitter housing", option D "Polycarbonate" and order code for "Integrated ISEM electronics", option A "Sensor"

A [in]	F [in]	G [in]	N [in]	P [in]	Q [in]
6.97	9.21	3.50	7.76	0.67	0.87

Sensor with connection housing

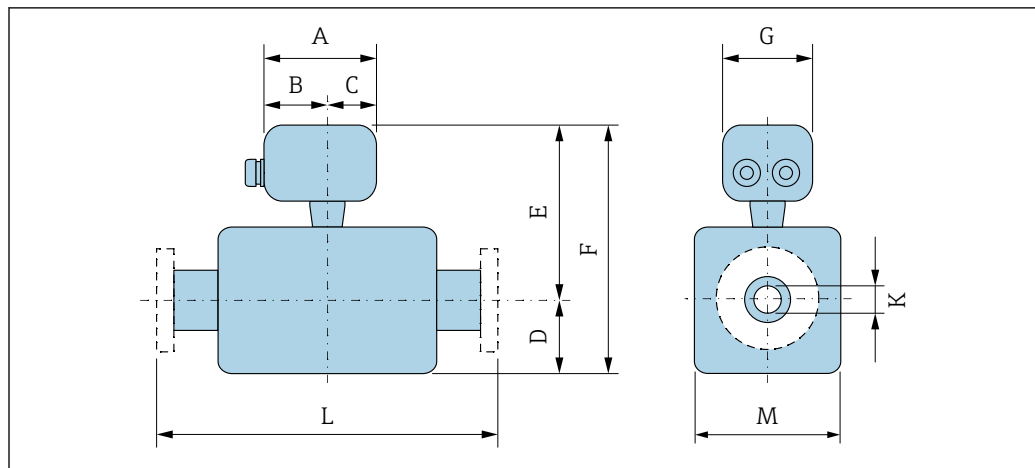

A0033784

L Installed length with specific process connection → 57

Order code for "Sensor connection housing", option A "Aluminum, coated"

A ¹⁾ [in]	B ¹⁾ [in]	C [in]	G [in]
5.83	3.7	2.13	5.35

1) Depending on the cable gland used: values up to + 1.18 in

Order code for "Sensor connection housing", option L "Cast, stainless"

A ¹⁾ [in]	B ¹⁾ [in]	C [in]	G [in]
5.71	3.39	2.32	5.35

1) Depending on the cable gland used: values up to + 1.18 in

Order code for "Sensor connection housing", option A "Aluminum, coated"

DN [in]	D [in]	E [in]	F [in]	M [in]	K [in]	L ¹⁾ [in]
½	0.51	9.53	10.04	1.42	0.56	9.65
1	0.67	9.53	10.2	1.42	0.96	9.65
1 ½	0.94	9.72	10.67	1.89	1.5	12.6
2	1.18	9.61	10.79	2.36	1.94	15.75
2 ½	1.85	9.92	11.38	2.87	2.47	20.47
3	1.61	10	11.61	3.25	2.85	25.2
4	2.13	10.2	12.32	4.25	3.78	31.5

1) With order code for "Sensor connection housing", option L "Cast, stainless" + 0.16 in

Flange connections

Welding neck flange ASME B16.5

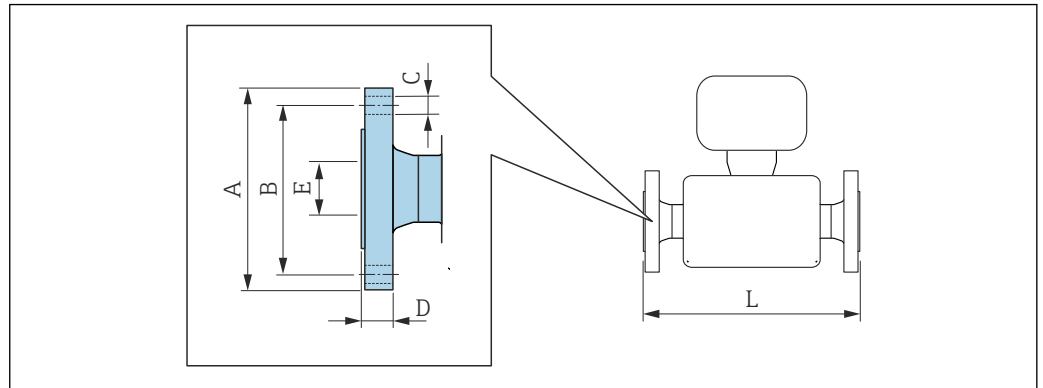

A0015621

i Length tolerance for dimension L in inch:
+0.06 / -0.08

Flange according to ASME B16.5: Class 150 RF, Schedule 40 and 80						
1.4404 (F316/F316L): order code for "Process connection", option AAS						
1.4404 (F316/F316L): order code for "Process connection", option AFS						
DN [in]	A [in]	B [in]	C [in]	D [in]	E [in]	L [in]
½	3.5	2.38	4 × Ø 0.62	0.44	0.55	9.65
1	4.25	3.12	4 × Ø 0.62	0.62	0.96	9.65
1½	5	3.88	4 × Ø 0.62	0.69	1.5	12.6
2	6	4.75	4 × Ø 0.75	0.75	1.94	15.75
2½	7	5.5	4 × Ø 0.75	0.89	2.47	20.47
3	7.5	6	4 × Ø 0.75	0.94	2.9	25.2
4	9	7.5	8 × Ø 0.75	0.96	3.82	31.5

Surface roughness (flange): ASME B16.5 "raised face", Ra 125 to 250µin

Flange according to ASME B16.5: Class 300 RF, Schedule 40 and 80						
1.4404 (F316/F316L): order code for "Process connection", option ABS						
1.4404 (F316/F316L): order code for "Process connection", option AGS						
DN [in]	A [in]	B [in]	C [in]	D [in]	E [in]	L [in]
½	3.74	2.62	4 × Ø 0.62	0.56	0.55	9.65
1	4.87	3.5	4 × Ø 0.75	0.75	0.96	9.65
1½	6.13	4.5	4 × Ø 0.88	0.81	1.5	12.6
2	6.5	5	8 × Ø 0.75	0.88	1.94	15.75
2½	7.5	5.9	8 × Ø 0.88	1	2.5	20.47
3	8.27	6.62	8 × Ø 0.88	1.12	2.9	25.2
4	10	7.88	8 × Ø 0.88	1.25	3.82	31.5

Surface roughness (flange): ASME B16.5 "raised face", Ra 125 to 250µin

Threaded connections

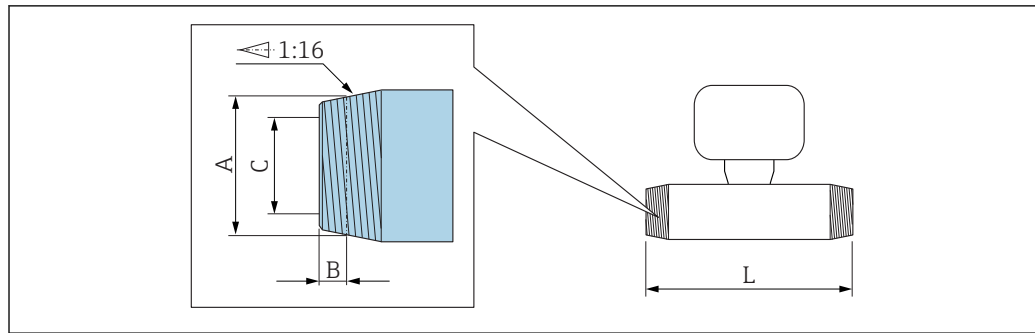

A0039448

R external thread as per EN 10226-1, ISO 7-1
Order code for "Process connection", option RAA

DN [in]	A [in]	B [in]	C [in]
½	R ½	0.32	0.55
1	R 1	0.41	0.96
1½	R 1½	0.5	1.5
2	R 2	0.63	1.94
2½	R 2½	0.69	2.47
3	R 3	0.81	2.85
4	R 4	1	3.78

NPT external thread as per ASME B1.20.1
Order code for "Process connection", option NPT

DN [in]	A [in]	B [in]	C [in]
½	½ NPT	0.32	0.62
1	1 NPT	0.4	1.05
1½	1½ NPT	0.42	1.61
2	2 NPT	0.44	2.07
2½	2½ NPT	0.68	2.47
3	3 NPT	0.77	2.85
4	4 NPT	0.84	3.78

Accessories

Flow conditioner

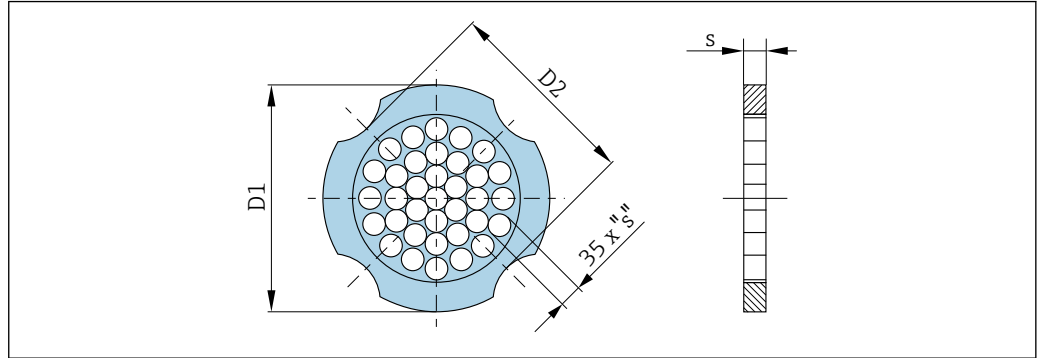

A0033504

**Used in combination with flanges according to ASME B16.5: Class 150
1.4404 (316, 316L)
Can be ordered separately as an "Accessory": DK6004**

DN [in]	Centering diameter [in]	D1 ¹⁾ / D2 ²⁾	s [in]
3	5.45	D1	0.40
4	6.95	D2	0.52
6	8.81	D1	0.79
8	10.80	D2	1.04
10	13.40	D1	1.30
12	15.90	D1	1.56

- 1) The flow conditioner is fitted at the outer diameter between the bolts.
- 2) The flow conditioner is fitted at the indentations between the bolts.

**Used in combination with flanges according to ASME B16.5: Class 300
1.4404 (316, 316L)
Can be ordered separately as an "Accessory": DK6004**

DN [in]	Centering diameter [in]	D1 ¹⁾ / D2 ²⁾	s [in]
3	5.96	D1	0.40
4	7.19	D1	0.52
6	9.92	D1	0.79
8	12.20	D1	1.04
10	14.30	D1	1.30
12	15.80	D1	1.56

- 1) The flow conditioner is fitted at the outer diameter between the bolts.
- 2) The flow conditioner is fitted at the indentations between the bolts.

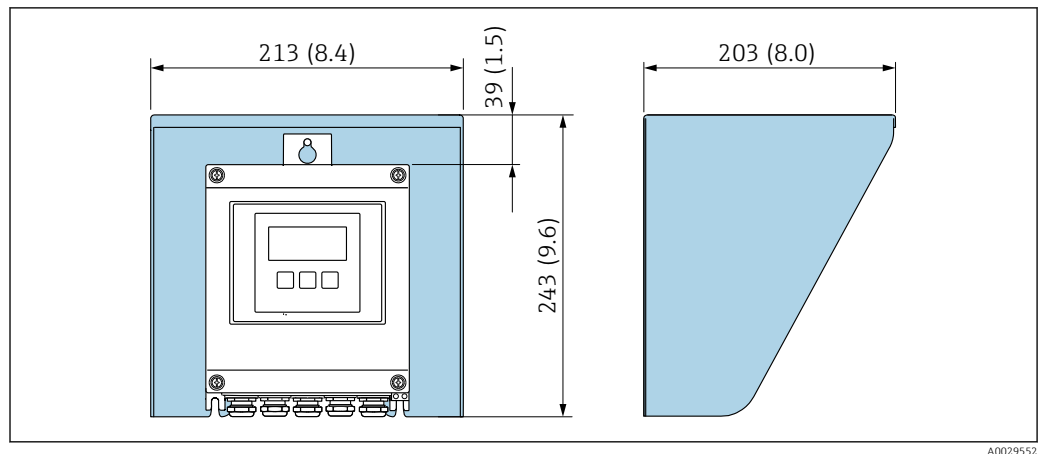
Protective cover

32 Protective cover for Proline 500 – digital; engineering unit mm (in)

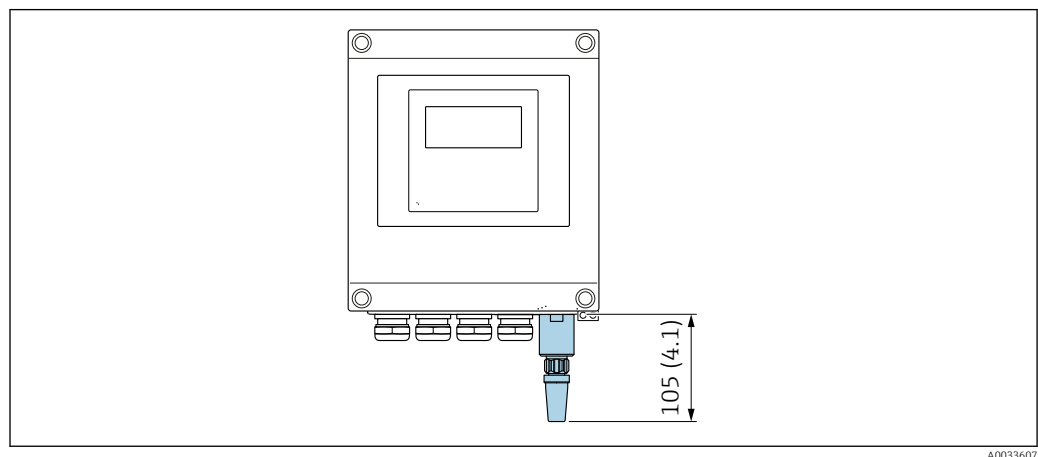
*External WLAN antenna**Proline 500 – digital**External WLAN antenna mounted on device*

33 Engineering unit mm (in)

External WLAN antenna mounted with cable

The external WLAN antenna can be mounted separately from the transmitter if the transmission/reception conditions at the transmitter mounting location are poor.

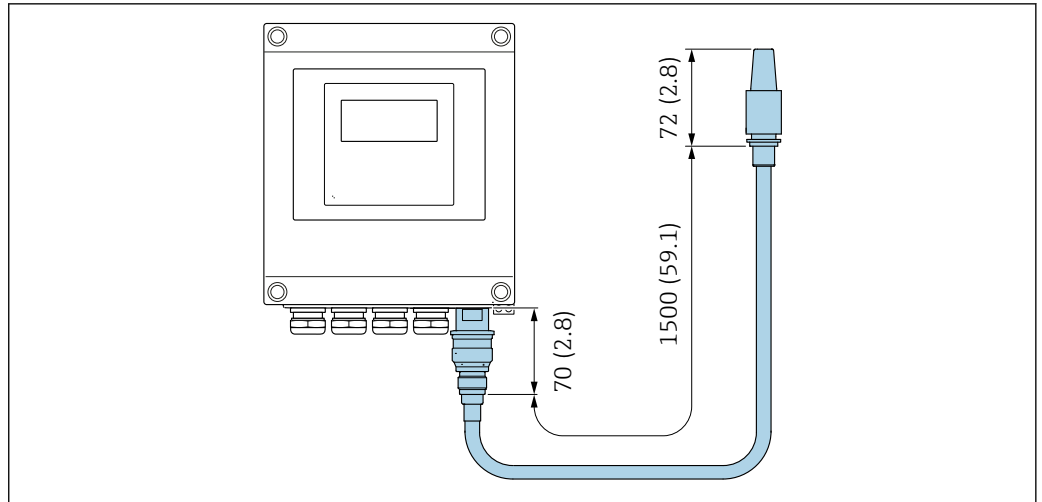

34 Engineering unit mm (in)

Materials

Transmitter housing

Housing of Proline 500 – digital transmitter

Order code for "Transmitter housing":

- Option **A** "Aluminum coated": aluminum, AlSi10Mg, coated
- Option **D** "Polycarbonate": polycarbonate

Window material

Order code for "Transmitter housing":

- Option **A** "Aluminum, coated": glass
- Option **D** "Polycarbonate": plastic

Fastening components for mounting on a post

- Screws, threaded bolts, washers, nuts: stainless A2 (chrome-nickel steel)
- Metal plates: stainless steel, 1.4301 (304)

Sensor connection housing

Order code for "Sensor connection housing":

- Option **A** "Aluminum coated": aluminum, AlSi10Mg, coated
- Option **L** "Cast, stainless": 1.4409 (CF3M) similar to 316L

Cable entries/cable glands

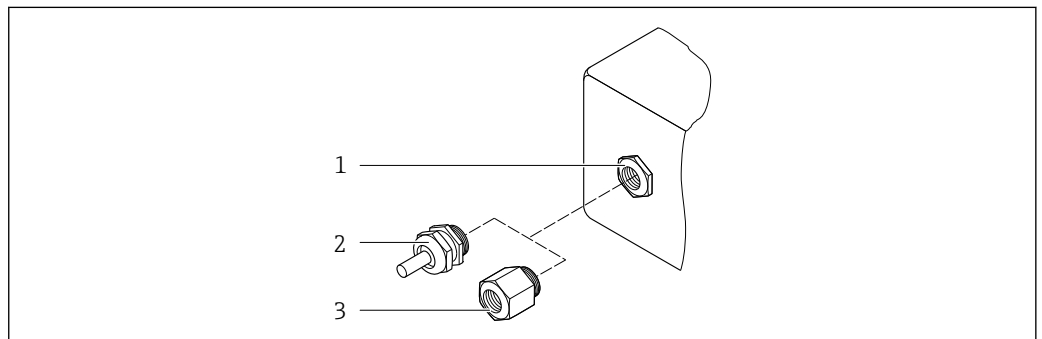

35 Possible cable entries/cable glands

- 1 Female thread M20 × 1.5
- 2 Cable gland M20 × 1.5
- 3 Adapter for cable entry with female thread G ½" or NPT ½"

Cable entries and adapters	Material
Cable gland M20 × 1.5	Plastic
<ul style="list-style-type: none"> ■ Adapter for cable entry with female thread G ½" ■ Adapter for cable entry with female thread NPT ½" <p> Only available for certain device versions:</p> <ul style="list-style-type: none"> ■ Order code for "Transmitter housing": <ul style="list-style-type: none"> ■ Option A "Aluminum, coated" ■ Option D "Polycarbonate" ■ Order code for "Sensor connection housing": <ul style="list-style-type: none"> Proline 500 – digital: Option A "Aluminum coated" Option L "Cast, stainless" 	Nickel-plated brass

Measuring tubes

- DN 15 to 50 (½ to 2"): stainless cast steel, CF3M/1.4408
- DN 65 to 100 (2½ to 4"): stainless steel, 1.4404 (316/316L)

Process connections

Flange connections

Stainless steel, 1.4404 (F316/F316L)

Threaded connections

Stainless steel, 1.4404 (316/316L)

Sensing element

Unidirectional

- Stainless steel, 1.4404 (316/316L)
- Alloy C22, 2.4602 (UNS N06022);

Bidirectional

Stainless steel, 1.4404 (316/316L)

Reverse flow detection

Stainless steel, 1.4404 (316/316L)

Accessories

Protective cover

Stainless steel, 1.4404 (316L)

External WLAN antenna

- Antenna: ASA plastic (acrylic ester-styrene-acrylonitrile) and nickel-plated brass
- Adapter: Stainless steel and nickel-plated brass
- Cable: Polyethylene
- Plug: Nickel-plated brass
- Angle bracket: Stainless steel

Weight

Transmitter

- Proline 500 – digital polycarbonate: 1.4 kg (3.1 lbs)
- Proline 500 – digital aluminum: 2.4 kg (5.3 lbs)

Sensor

- Sensor with aluminum connection housing version: see the information in the following table
- Sensor with cast connection housing version, stainless: +3.7 kg (+8.2 lbs)

Weight in SI units

DN [mm]	Weight [kg]
15	4
25	5.2
40	7.4

DN [mm]	Weight [kg]
50	9.8
65	13.1
80	16.8
100	25.6

Weight in US units

DN [in]	Weight [lbs]
½	9
1	11
1½	16
2	22
2½	29
3	37
4	56

Process connections

- EN 1092-1-B1
- ASME B16.5
- JIS B2220



For information on the different materials used in the process connections → 62

Human interface

Operating concept

Operator-oriented menu structure for user-specific tasks

- Commissioning
- Operation
- Diagnostics
- Expert level

Fast and safe commissioning

- Guided menus ("Make-it-run" wizards) for applications
- Menu guidance with brief descriptions of the individual parameter functions
- Access to the device via Web server → 76
- WLAN access to the device via mobile handheld terminal, tablet or smart phone

Reliable operation

- Operation in local language → 64
- Uniform operating philosophy applied to device and operating tools
- If replacing electronic modules, transfer the device configuration via the integrated memory (HistoROM backup) which contains the process and measuring device data and the event logbook. No need to reconfigure.

Efficient diagnostics increase measurement availability

- Troubleshooting measures can be called up via the device and in the operating tools
- Diverse simulation options, logbook for events that occur and optional line recorder functions

Languages

Can be operated in the following languages:

- Via local operation
 - English, German, French, Spanish, Italian, Dutch, Portuguese, Polish, Russian, Turkish, Chinese, Japanese, Korean, Bahasa (Indonesian), Vietnamese, Czech, Swedish
- Via Web browser
 - English, German, French, Spanish, Italian, Dutch, Portuguese, Polish, Russian, Turkish, Chinese, Japanese, Korean, Bahasa (Indonesian), Vietnamese, Czech, Swedish
- Via "FieldCare", "DeviceCare" operating tool: English, German, French, Spanish, Italian, Chinese, Japanese

Local operation**Via display module**

Equipment:



- Order code for "Display; operation", option F "4-line, illuminated, graphic display; touch control"
- Order code for "Display; operation", option G "4-line, illuminated, graphic display; touch control + WLAN"

 Information about WLAN interface →  66

Display elements

- 4-line, illuminated, graphic display
- White background lighting; switches to red in event of device errors
- Format for displaying measured variables and status variables can be individually configured
- Permitted ambient temperature for the display: -20 to +60 °C (-4 to +140 °F)
The readability of the display may be impaired at temperatures outside the temperature range.

Operating elements

- External operation via touch control (3 optical keys) without opening the housing:  ,  , 
- Operating elements also accessible in the various zones of the hazardous area

Remote operation**Via HART protocol**

This communication interface is available in device versions with a HART output.

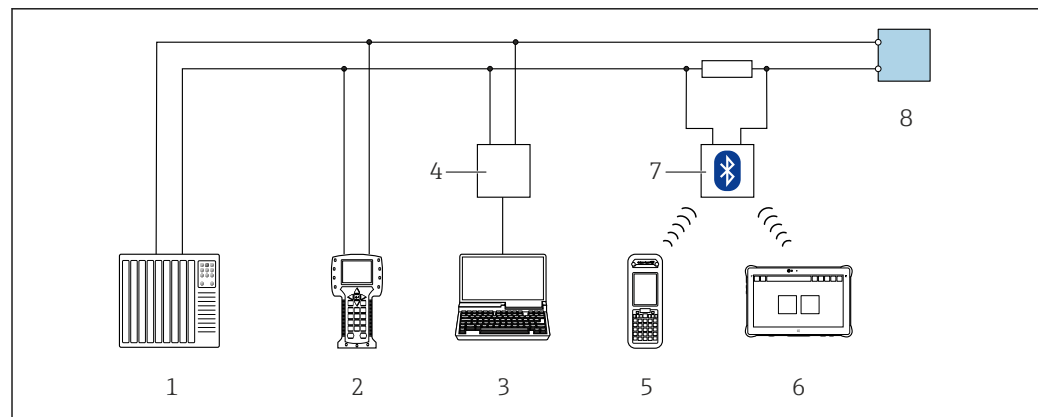

 36 Options for remote operation via HART protocol (active)

- 1 Control system (e.g. PLC)
- 2 Field Communicator 475
- 3 Computer with Web browser (e.g. Internet Explorer) for access to the integrated device Web server or computer with an operating tool (e.g. FieldCare, DeviceCare, AMS Device Manager, SIMATIC PDM) with COM DTM "CDI Communication TCP/IP"
- 4 Commubox FXA195 (USB)
- 5 Field Xpert SFX350 or SFX370
- 6 Field Xpert SMT70
- 7 VIATOR Bluetooth modem with connecting cable
- 8 Transmitter

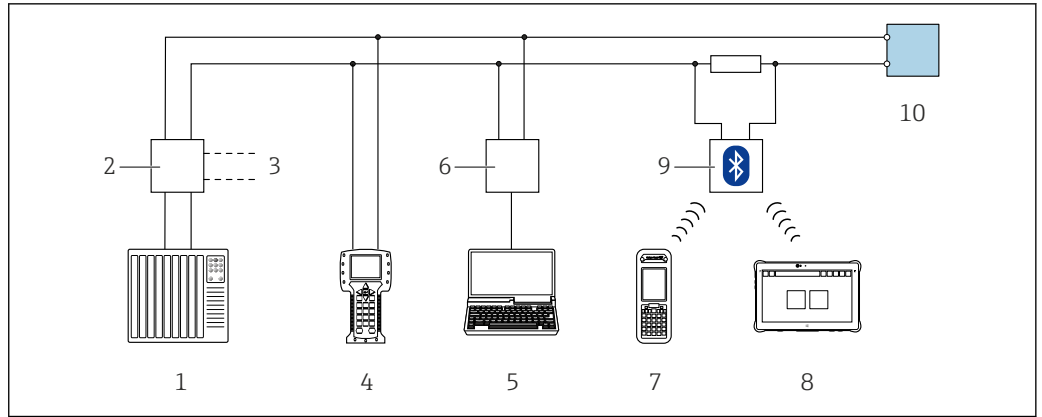

A0028746

37 Options for remote operation via HART protocol (passive)

- 1 Control system (e.g. PLC)
- 2 Transmitter power supply unit, e.g. RN22 1N (with communication resistor)
- 3 Connection for Commubox FXA195 and Field Communicator 475
- 4 Field Communicator 475
- 5 Computer with Web browser (e.g. Internet Explorer) for access to the integrated device Web server or computer with an operating tool (e.g. FieldCare, DeviceCare, AMS Device Manager, SIMATIC PDM) with COM DTM "CDI Communication TCP/IP"
- 6 Commubox FXA195 (USB)
- 7 Field Xpert SFX350 or SFX370
- 8 Field Xpert SMT70
- 9 VIATOR Bluetooth modem with connecting cable
- 10 Transmitter

Via Modbus RS485 protocol

This communication interface is available in device versions with a Modbus-RS485 output.

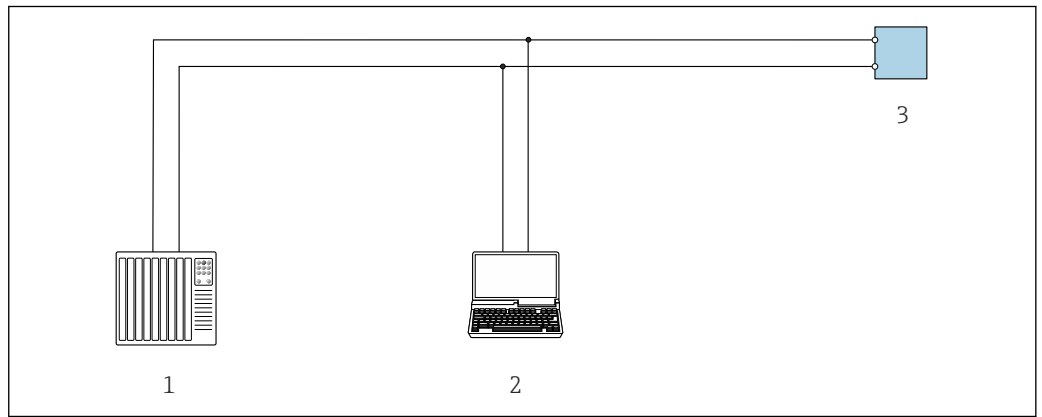

A0029437

38 Options for remote operation via Modbus-RS485 protocol (active)

- 1 Control system (e.g. PLC)
- 2 Computer with Web browser (e.g. Internet Explorer) for accessing the integrated device Web server or with operating tool (e.g. FieldCare, DeviceCare) with COM DTM "CDI Communication TCP/IP" or Modbus DTM
- 3 Transmitter

Service interface

Via service interface (CDI-RJ45)

A point-to-point connection can be established to configure the device onsite. With the housing open, the connection is established directly via the service interface (CDI-RJ45) of the device.

i An adapter for RJ45 and the M12 connector is optionally available:
Order code for "Accessories", option **NB**: "Adapter RJ45 M12 (service interface)"

The adapter connects the service interface (CDI-RJ45) to an M12 connector mounted in the cable entry. Therefore the connection to the service interface can be established via an M12 connector without opening the device.

Proline 500 – digital transmitter

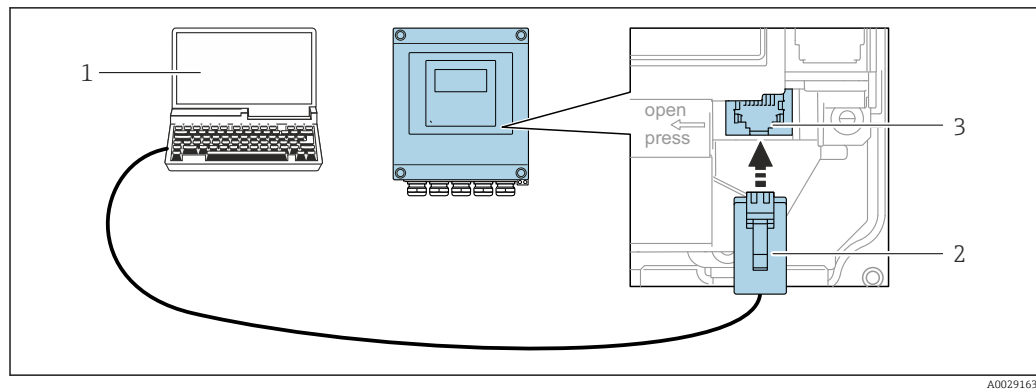

39 Connection via service interface (CDI-RJ45)

- 1 Computer with Web browser (e.g. Microsoft Internet Explorer, Microsoft Edge) for accessing the integrated device Web server or with "FieldCare", "DeviceCare" operating tool with COM DTM "CDI Communication TCP/IP" or Modbus DTM
- 2 Standard Ethernet connecting cable with RJ45 connector
- 3 Service interface (CDI-RJ45) of the measuring device with access to the integrated Web server

Via WLAN interface



The optional WLAN interface is available on the following device version:

Order code for "Display; operation", option G "4-line, illuminated; touch control + WLAN"

Function	WLAN: IEEE 802.11 b/g (2.4 GHz) <ul style="list-style-type: none"> ▪ Access point with DHCP server (default setting) ▪ Network
Encryption	WPA2-PSK AES-128 (in accordance with IEEE 802.11i)
Configurable WLAN channels	1 to 11
Degree of protection	IP67
Available antennas	<ul style="list-style-type: none"> ▪ Internal antenna ▪ External antenna (optional) In the event of poor transmission/reception conditions at the place of installation. Available as an accessory → 75. <p> Only one antenna active in each case!</p>
Range	<ul style="list-style-type: none"> ▪ Internal antenna: typically 10 m (32 ft) ▪ External antenna: typically 50 m (164 ft)
Materials (external antenna)	<ul style="list-style-type: none"> ▪ Antenna: ASA plastic (acrylic ester-styrene-acrylonitrile) and nickel-plated brass ▪ Adapter: Stainless steel and nickel-plated brass ▪ Cable: Polyethylene ▪ Connector: Nickel-plated brass ▪ Angle bracket: Stainless steel

Supported operating tools

Different operating tools can be used for local or remote access to the measuring device. Depending on the operating tool used, access is possible with different operating units and via a variety of interfaces.

Supported operating tools	Operating unit	Interface	Additional information
Web browser	Notebook, PC or tablet with Web browser	<ul style="list-style-type: none"> ■ CDI-RJ45 service interface ■ WLAN interface 	Special Documentation for device
DeviceCare SFE100	Notebook, PC or tablet with Microsoft Windows system	<ul style="list-style-type: none"> ■ CDI-RJ45 service interface ■ WLAN interface ■ Fieldbus protocol 	→  76
FieldCare SFE500	Notebook, PC or tablet with Microsoft Windows system	<ul style="list-style-type: none"> ■ CDI-RJ45 service interface ■ WLAN interface ■ Fieldbus protocol 	→  76
Device Xpert	Field Xpert SFX 100/350/370	HART fieldbus protocol	Operating Instructions BA01202S Device description files: Use update function of handheld terminal



Other operating tools based on FDT technology with a device driver such as DTM/iDTM or DD/EDD can be used for device operation. These operating tools are available from the individual manufacturers. Integration into the following operating tools, among others, is supported:

- FactoryTalk AssetCentre (FTAC) by Rockwell Automation → www.rockwellautomation.com
- Process Device Manager (PDM) by Siemens → www.siemens.com
- Asset Management Solutions (AMS) by Emerson → www.emersonprocess.com
- FieldCommunicator 375/475 by Emerson → www.emersonprocess.com
- Field Device Manager (FDM) by Honeywell → www.honeywellprocess.com
- FieldMate by Yokogawa → www.yokogawa.com
- PACTWare → www.pactware.com

The associated device description files are available at: www.endress.com → Downloads

Web server

Thanks to the integrated Web server, the device can be operated and configured via a Web browser and via a service interface (CDI-RJ45) or via a WLAN interface. The structure of the operating menu is the same as for the local display. In addition to the measured values, status information on the device is also displayed and allows the user to monitor the status of the device. Furthermore the device data can be managed and the network parameters can be configured.

A device that has a WLAN interface (can be ordered as an option) is required for the WLAN connection: order code for "Display; operation", option G "4-line, illuminated; touch control + WLAN". The device acts as an Access Point and enables communication by computer or a mobile handheld terminal.

Supported functions

Data exchange between the operating unit (such as a notebook for example) and the measuring device:

- Upload the configuration from the measuring device (XML format, configuration backup)
- Save the configuration to the measuring device (XML format, restore configuration)
- Export event list (.csv file)
- Export parameter settings (.csv file or PDF file, document the measuring point configuration)
- Export the Heartbeat verification log (PDF file, only available with the "Heartbeat Verification" application package)
- Flash firmware version for device firmware upgrade, for instance
- Download driver for system integration
- Visualize up to 1000 saved measured values (only available with the **Extended HistoROM** application package →  74)



Web server special documentation

HistoROM data management The measuring device features HistoROM data management. HistoROM data management comprises both the storage and import/export of key device and process data, making operation and servicing far more reliable, secure and efficient.

-  When the device is delivered, the factory settings of the configuration data are stored as a backup in the device memory. This memory can be overwritten with an updated data record, for example after commissioning.

Additional information on the data storage concept

There are different types of data storage units in which device data are stored and used by the device:

	Device memory	T-DAT	S-DAT
Available data	<ul style="list-style-type: none"> ▪ Event logbook such as diagnostic events for example ▪ Parameter data record backup ▪ Device firmware package 	<ul style="list-style-type: none"> ▪ Measured value logging ("Extended HistoROM" order option) ▪ Current parameter data record (used by firmware at run time) ▪ Peakhold indicator (min/max values) ▪ Totalizer values 	<ul style="list-style-type: none"> ▪ Sensor data: nominal diameter etc. ▪ Serial number ▪ Calibration data ▪ Device configuration (e.g. SW options, fixed I/O or multi I/O)
Storage location	Fixed on the user interface board in the connection compartment	Attachable to the user interface board in the connection compartment	In the sensor plug in the transmitter neck part

Data backup

Automatic

- The most important device data (sensor and transmitter) are automatically saved in the DAT modules
- If the transmitter or measuring device is replaced: once the T-DAT containing the previous device data has been exchanged, the new measuring device is ready for operation again immediately without any errors
- If the sensor is replaced: once the sensor has been replaced, new sensor data are transferred from the S-DAT in the measuring device and the measuring device is ready for operation again immediately without any errors
- If exchanging the electronics module (e.g. I/O electronics module): Once the electronics module has been replaced, the software of the module is compared against the current device firmware. The module software is upgraded or downgraded where necessary. The electronics module is available for use immediately afterwards and no compatibility problems occur.

Manual

Additional parameter data record (complete parameter settings) in the integrated device memory HistoROM backup for:

- Data backup function
Backup and subsequent restoration of a device configuration in the device memory HistoROM backup
- Data comparison function
Comparison of the current device configuration with the device configuration saved in the device memory HistoROM backup

Data transfer

Manual

Transfer of a device configuration to another device using the export function of the specific operating tool, e.g. with FieldCare, DeviceCare or Web server: to duplicate the configuration or to store in an archive (e.g. for backup purposes)

Event list

Automatic

- Chronological display of up to 20 event messages in the events list
- If the **Extended HistoROM** application package (order option) is enabled: up to 100 event messages are displayed in the events list along with a time stamp, plain text description and remedial measures
- The events list can be exported and displayed via a variety of interfaces and operating tools e.g. DeviceCare, FieldCare or Web server

Data logging

Manual

If the **Extended HistoROM** application package (order option) is enabled:

- Record up to 1 000 measured values via 1 to 4 channels
- User configurable recording interval
- Record up to 250 measured values via each of the 4 memory channels
- Export the measured value log via a variety of interfaces and operating tools e.g. FieldCare, DeviceCare or web server

Certificates and approvals

 Currently available certificates and approvals can be called up via the product configurator.

CE mark The device meets the legal requirements of the applicable EU Directives. These are listed in the corresponding EU Declaration of Conformity along with the standards applied.
Endress+Hauser confirms successful testing of the device by affixing to it the CE mark.

RCM-tick symbol The measuring system meets the EMC requirements of the "Australian Communications and Media Authority (ACMA)".

Ex approval The measuring device is certified for use in hazardous areas and the relevant safety instructions are provided in the separate "Safety Instructions" (XA) document. Reference is made to this document on the nameplate.

 The separate Ex documentation (XA) containing all the relevant explosion protection data is available from your Endress+Hauser sales center.

Proline 500 – digital

ATEX/IECEX

Currently, the following versions for use in hazardous areas are available:

Ex db

Transmitter		Sensor	
Category	Type of protection	Category	Type of protection
II(1)G	[Ex ia] IIC	II1/2G	Ex db ia IIC T4...T1 Ga/Gb
II(1)G	[Ex ia] IIC	II2G	Ex db ia IIC T4...T1 Gb
II3G	Ex ec nC [ia Ga] IIC T5...T1 Gc	II1/2G	Ex db ia IIC T4...T1 Ga/Gb
II3G	Ex ec nC [ia Ga] IIC T5...T1 Gc	II2G	Ex db ia IIC T4...T1 Gb

Ex tb

Transmitter		Sensor	
Category	Type of protection	Category	Type of protection
II(1)D	[Ex ia] IIIC	II2D	Ex tb IIIC T** °C Db

Non-Ex / Ex ec

Transmitter		Sensor	
Category	Type of protection	Category	Type of protection
Non - Ex	Non-Ex	II3G	Ex ec IIC T4...T1 Gc
II3G	Ex ec nC IIC T5...T1 Gc	II3G	Ex ec IIC T4...T1 Gc

cCSA_{US}

Currently, the following versions for use in hazardous areas are available:

IS (Ex nA, Ex i)

Transmitter	Sensor
Class I Division 2 Groups A - D	Class I, II, III Division 1 Groups A-G

NI (Ex nA)

Transmitter	Sensor
Class I Division 2 Groups A - D	Class I Division 2 Groups A - D

Ex db

Transmitter	Sensor
Ex ec nC [ia Ga] IIC T5...T1 Gc	Ex db ia IIC T4...T1 Gb
Ex ec nC [ia Ga] IIC T5...T1 Gc	Ex db ia IIC T4...T1 Ga/Gb

Ex nA

Transmitter	Sensor
Class I, Zone 2 AEx/ Ex nA IIC T5...T4 Gc	Class I, Zone 2 AEx/ Ex nA IIC T5...T1 Gc

Ex tb

Transmitter	Sensor
Non - Ex	Zone 21, AEx/Ex ia tb IIC T** °C Db

Functional safety

The measuring device can be used for flow monitoring systems (min., max., range) up to SIL 2 (single-channel architecture; order code for "Additional approval", option LA) and SIL 3 (multichannel architecture with homogeneous redundancy) and is independently evaluated and certified by the TÜV in accordance with IEC 61508.

The following types of monitoring in safety equipment are possible:

Mass flow



Functional Safety Manual with information on the SIL device

HART certification

HART interface

The measuring device is certified and registered by the FieldComm Group. The measuring system meets all the requirements of the following specifications:

- Certified according to HART 7
- The device can also be operated with certified devices of other manufacturers (interoperability)

Radio approval

The measuring device has radio approval.



For detailed information regarding radio approval, see Special Documentation

Pressure Equipment Directive

The devices can be ordered with or without a PED approval. If a device with a PED approval is required, this must be explicitly stated in the order. For devices with nominal diameters less than or equal to DN 25 (1"), this is neither possible nor necessary.

- With the identification PED/G1/x (x = category) on the sensor nameplate, Endress+Hauser confirms conformity with the "Essential Safety Requirements" specified in Appendix I of the Pressure Equipment Directive 2014/68/EU.
- Devices bearing this marking (PED) are suitable for the following types of medium: Media in Group 1 and 2 with a vapor pressure greater than, or smaller and equal to 0.5 bar (7.3 psi)
- Devices not bearing this marking (PED) are designed and manufactured according to good engineering practice. They meet the requirements of Article 4 paragraph 3 of the Pressure Equipment Directive 2014/68/EU. The range of application is indicated in tables 6 to 9 in Annex II of the Pressure Equipment Directive 2014/68/EU.

Additional certification

CRN approval

Some device versions have CRN approval. A CRN-approved process connection with a CSA approval must be ordered for a CRN-approved device.

Other standards and guidelines

- EN 60529
Degrees of protection provided by enclosures (IP code)
- EN 61010-1
Safety requirements for electrical equipment for measurement, control and laboratory use - general requirements
- IEC/EN 61326
Emission in accordance with Class A requirements. Electromagnetic compatibility (EMC requirements).
- NAMUR NE 21
Electromagnetic compatibility (EMC) of industrial process and laboratory control equipment
- NAMUR NE 32
Data retention in the event of a power failure in field and control instruments with microprocessors
- NAMUR NE 43
Standardization of the signal level for the breakdown information of digital transmitters with analog output signal.
- NAMUR NE 53
Software of field devices and signal-processing devices with digital electronics
- NAMUR NE 105
Specifications for integrating fieldbus devices in engineering tools for field devices
- NAMUR NE 107
Self-monitoring and diagnosis of field devices
- NAMUR NE 131
Requirements for field devices for standard applications

Classification of process sealing between electrical systems and (flammable or combustible) process fluids in accordance with ANSI/ISA 12.27.01

Endress+Hauser devices are designed in accordance with ANSI/ISA 12.27.01, allowing the user to waive the use and save the cost of installing external secondary process seals in the conduit as required by the process sealing sections of ANSI/NFPA 70 (NEC) and CSA 22.1 (CEC). These devices comply with the North American installation practice and provide a very safe and cost-saving installation for pressurized applications with hazardous fluids. Further information can be found in the control drawings of the relevant devices.

Ordering information

Detailed ordering information is available as follows:

- In the Product Configurator on the Endress+Hauser website: www.endress.com -> Click "Corporate" -> Select your country -> Click "Products" -> Select the product using the filters and search field -> Open product page -> The "Configure" button to the right of the product image opens the Product Configurator.
- From your Endress+Hauser Sales Center: www.addresses.endress.com



Product Configurator - the tool for individual product configuration

- Up-to-the-minute configuration data
- Depending on the device: Direct input of measuring point-specific information such as measuring range or operating language
- Automatic verification of exclusion criteria
- Automatic creation of the order code and its breakdown in PDF or Excel output format
- Ability to order directly in the Endress+Hauser Online Shop

Application packages

Many different application packages are available to enhance the functionality of the device. Such packages might be needed to address safety aspects or specific application requirements.

The application packages can be ordered with the device or subsequently from Endress+Hauser. Detailed information on the order code in question is available from your local Endress+Hauser sales center or on the product page of the Endress+Hauser website: www.endress.com.



Detailed information on the application packages:
Special Documentation for the device → 78

Diagnostics functions

Package	Description
Extended HistoROM	<p>Comprises extended functions concerning the event log and the activation of the measured value memory.</p> <p>Event log: Memory volume is extended from 20 message entries (standard version) to up to 100 entries.</p> <p>Data logging (line recorder):</p> <ul style="list-style-type: none"> ▪ Memory capacity for up to 1000 measured values is activated. ▪ 250 measured values can be output via each of the 4 memory channels. The recording interval can be defined and configured by the user. ▪ Measured value logs can be accessed via the local display or operating tool e.g. FieldCare, DeviceCare or Web server.

Heartbeat Technology

Package	Description
Heartbeat Verification +Monitoring	<p>Heartbeat Verification Meets the requirement for traceable verification to DIN ISO 9001:2008 Chapter 7.6 a) "Control of monitoring and measuring equipment".</p> <ul style="list-style-type: none"> ▪ Functional testing in the installed state without interrupting the process. ▪ Traceable verification results on request, including a report. ▪ Simple testing process via local operation or other operating interfaces. ▪ Clear measuring point assessment (pass/fail) with high test coverage within the framework of manufacturer specifications. ▪ Extension of calibration intervals according to operator's risk assessment. <p>Heartbeat Monitoring Continuously supplies data, which are characteristic of the measuring principle, to an external condition monitoring system for the purpose of preventive maintenance or process analysis. These data enable the operator to:</p> <ul style="list-style-type: none"> ▪ Draw conclusions - using these data and other information - about the impact on the measuring performance over time. ▪ Schedule servicing in time. ▪ Monitor the process or product quality, e.g. process stability.

Second gas group















Package	Description
Second gas group	This application package enables the configuration of two different standard gases/gas mixtures in the device and allows the user to switch from one gas group to another using the status input or (if available) via bus communication.

Accessories





Various accessories, which can be ordered with the device or subsequently from Endress+Hauser, are available for the device. Detailed information on the order code in question is available from your local Endress+Hauser sales center or on the product page of the Endress+Hauser website: www.endress.com.

Device-specific accessories



For the transmitter

Accessories	Description
Transmitter Proline 500 – digital	<p>Transmitter for replacement or storage. Use the order code to define the following specifications:</p> <ul style="list-style-type: none"> ▪ Approvals ▪ Output ▪ Input ▪ Display/operation ▪ Housing ▪ Software <p> Proline 500 – digital transmitter: Order number: 6X5BXX-*****A</p> <p> Proline 500 transmitter for replacement: It is essential to specify the serial number of the current transmitter when ordering. Based on the serial number, the device-specific data (e.g., calibration factors) of the replacement device can be used for the new transmitter.</p> <p> Proline 500 – digital transmitter: Installation Instructions EA01287D</p>
External WLAN antenna	<p>External WLAN antenna with 1.5 m (59.1 in) connecting cable and two angle brackets. Order code for "Accessory enclosed", option P8 "Wireless antenna wide area".</p> <ul style="list-style-type: none">  The external WLAN antenna is not suitable for use in hygienic applications. ▪ Further information on the WLAN interface →  66. <p> Order number: 71351317</p> <p> Installation Instructions EA01238D</p>
Pipe mounting set	<p>Pipe mounting set for transmitter.</p> <p> Proline 500 – digital transmitter Order number: 71346427</p> <p> Installation Instructions EA01195D</p>
Protective cover Transmitter Proline 500 – digital	<p>Is used to protect the measuring device from the effects of the weather: e.g. rainwater, excess heating from direct sunlight.</p> <p> Proline 500 – digital transmitter Order number: 71343504</p> <p> Installation Instructions EA01191D</p>
Display guard Proline 500 – digital	<p>Is used to protect the display against impact or scoring from sand in desert areas.</p> <p> Order number: 71228792</p> <p> Installation Instructions EA01093D</p>
Connecting cable Proline 500 – digital Sensor – Transmitter	<p>The connecting cable can be ordered directly with the measuring device (order code for "Cable, sensor connection) or as an accessory (order number).</p> <p>The following cable lengths are available: order code for "Cable, sensor connection"</p> <ul style="list-style-type: none"> ▪ Option B: 20 m (65 ft) ▪ Option E: User configurable up to max. 50 m ▪ Option F: User configurable up to max. 165 ft <p> Maximum possible cable length for a Proline 500 – digital connecting cable: 300 m (1 000 ft)</p>









Communication-specific accessories

Accessories	Description
Commubox FXA195 HART	For intrinsically safe HART communication with FieldCare via the USB interface.  Technical Information TI00404F
HART Loop Converter HMX50	Is used to evaluate and convert dynamic HART process variables to analog current signals or limit values.  <ul style="list-style-type: none"> ▪ Technical Information TI00429F ▪ Operating Instructions BA00371F
Fieldgate FXA42	Is used to transmit the measured values of connected 4 to 20 mA analog measuring devices, as well as digital measuring devices  <ul style="list-style-type: none"> ▪ Technical Information TI01297S ▪ Operating Instructions BA01778S ▪ Product page: www.endress.com/fxa42
Field Xpert SMT70	The Field Xpert SMT70 tablet PC for device configuration enables mobile plant asset management in hazardous and non-hazardous areas. It is suitable for commissioning and maintenance staff to manage field instruments with a digital communication interface and to record progress. This tablet PC is designed as an all-in-one solution with a preinstalled driver library and is an easy-to-use, touch-sensitive tool which can be used to manage field instruments throughout their entire life cycle.  <ul style="list-style-type: none"> ▪ Technical Information TI01342S ▪ Operating Instructions BA01709S ▪ Product page: www.endress.com/smt70
Field Xpert SMT77	The Field Xpert SMT77 tablet PC for device configuration enables mobile plant asset management in areas categorized as Ex Zone 1.  <ul style="list-style-type: none"> ▪ Technical Information TI01418S ▪ Operating Instructions BA01923S ▪ Product page: www.endress.com/smt77

Service-specific accessories

Accessories	Description
Applicator	Software for selecting and sizing Endress+Hauser measuring devices: <ul style="list-style-type: none"> ▪ Choice of measuring devices for industrial requirements ▪ Calculation of all the necessary data for identifying the optimum flowmeter: e.g. nominal diameter, pressure loss, flow velocity and accuracy. ▪ Graphic illustration of the calculation results ▪ Determination of the partial order code, administration, documentation and access to all project-related data and parameters over the entire life cycle of a project. Applicator is available: <ul style="list-style-type: none"> ▪ Via the Internet: https://portal.endress.com/webapp/applicator ▪ As a downloadable DVD for local PC installation.
W@M	W@M Life Cycle Management Improved productivity with information at your fingertips. Data relevant to a plant and its components is generated from the first stages of planning and during the asset's complete life cycle. W@M Life Cycle Management is an open and flexible information platform with online and on-site tools. Instant access for your staff to current, in-depth data shortens your plant's engineering time, speeds up procurement processes and increases plant uptime. Combined with the right services, W@M Life Cycle Management boosts productivity in every phase. For more information, visit www.endress.com/lifecyclemanagement
FieldCare	FDT-based plant asset management tool from Endress+Hauser. It can configure all smart field units in your system and helps you manage them. By using the status information, it is also a simple but effective way of checking their status and condition.  Operating Instructions BA00027S and BA00059S
DeviceCare	Tool to connect and configure Endress+Hauser field devices.  Innovation brochure IN01047S

System components

Accessories	Description
Memograph M graphic data manager	<p>The Memograph M graphic data manager provides information on all the relevant measured variables. Measured values are recorded correctly, limit values are monitored and measuring points analyzed. The data are stored in the 256 MB internal memory and also on a SD card or USB stick.</p> <ul style="list-style-type: none">  Technical Information TI00133R  Operating Instructions BA00247R
Ceraphant PTC31B	<p>The pressure transmitter for measuring the absolute and gauge pressure in gases, steam, liquids and dusts. It can be used to read in the operating pressure value.</p> <ul style="list-style-type: none">  Technical Information TI01130P  Operating Instructions BA01270P
Cerabar PMC21	<p>The pressure transmitter for measuring the absolute and gauge pressure in gases, steam, liquids and dusts. It can be used to read in the operating pressure value.</p> <ul style="list-style-type: none">  Technical Information TI01133P  Operating Instructions BA01271P
Cerabar S PMC71	<p>The pressure transmitter for measuring the absolute and gauge pressure of gases, steam and liquids. It can be used to read in the operating pressure value.</p> <ul style="list-style-type: none">  Technical Information TI00383P  Operating Instructions BA00271P

Supplementary documentation



For an overview of the scope of the associated Technical Documentation, refer to the following:

- *W@M Device Viewer* (www.endress.com/deviceviewer): Enter the serial number from nameplate
- *Endress+Hauser Operations App*: Enter the serial number from the nameplate or scan the 2D matrix code (QR code) on the nameplate

Standard documentation Brief Operating Instructions

Brief Operating Instructions for the sensor

Measuring device	Documentation code
Proline t-mass F	KA01442D

Brief Operating Instructions for transmitter

Measuring device	Documentation code	
	HART	Modbus RS485
Proline 500 – digital	KA01446D	KA01447D

Operating Instructions

Measuring device	Documentation code	
	HART	Modbus RS485
t-mass F 500	BA01996D	BA01998D

Description of Device Parameters

Measuring device	Documentation code	
	HART	Modbus RS485
t-mass 500	GP01145D	GP01146D

Device-dependent additional documentation

Safety instructions

Safety instructions for electrical equipment for hazardous areas.

Contents	Documentation code
ATEX/IECEX Ex d/Ex de	XA01970D
ATEX/IECEX Ex ec	XA01971D
cCSAus XP	XA01974D
cCSAus Ex d/ Ex de	XA01972D
cCSAus Ex nA	XA01973D

Remote display and operating module DKX001

Contents	Documentation code
ATEX/IECEX Ex i	XA01494D
ATEX/IECEX Ex ec	XA01498D
cCSAus IS	XA01499D
cCSAus Ex nA	XA01513D
INMETRO Ex i	XA01500D

Contents	Documentation code
INMETRO Ex ec	XA01501D
NEPSI Ex i	XA01502D
NEPSI Ex nA	XA01503D

Special Documentation

Contents	Documentation code	
	HART	Modbus RS485
Functional Safety Manual	SD02484D	-
Heartbeat Technology	SD02479D	SD02480D
Web server	SD02487D	SD02488D

Installation Instructions

Contents	Comment
Installation instructions for spare part sets and accessories	Documentation code: specified for each individual accessory .

Registered trademarks

HART®

Registered trademark of the FieldComm Group, Austin, Texas, USA

Modbus®

Registered trademark of SCHNEIDER AUTOMATION, INC.

www.addresses.endress.com
