

Instruction Manual

IB-102-208P Rev. 1.1

November 2001

PowerVUE™

Fan/Damper Actuator Torque
Type 8 x 14 with Retrofit Kit
Installation Instructions



ROSEMOUNT®
Analytical

<http://www.processanalytic.com>

EMERSON™
Process Management

ESSENTIAL INSTRUCTIONS

READ THIS PAGE BEFORE PROCEEDING!

Rosemount Analytical designs, manufactures and tests its products to meet many national and international standards. Because these instruments are sophisticated technical products, you **MUST properly install, use, and maintain them** to ensure they continue to operate within their normal specifications. The following instructions **MUST be adhered to** and integrated into your safety program when installing, using, and maintaining Rosemount Analytical products. Failure to follow the proper instructions may cause any one of the following situations to occur: Loss of life; personal injury; property damage; damage to this instrument; and warranty invalidation.

- **Read all instructions** prior to installing, operating, and servicing the product.
- If you do not understand any of the instructions, **contact your Rosemount Analytical representative** for clarification.
- **Follow all warnings, cautions, and instructions** marked on and supplied with the product.
- **Inform and educate your personnel in the proper installation, operation, and maintenance of the product.**
- **Install your equipment as specified in the Installation Instructions of the appropriate Instruction Manual and per applicable local and national codes.** Connect all products to the proper electrical and pressure sources.
- To ensure proper performance, **use qualified personnel** to install, operate, update, program, and maintain the product.
- When replacement parts are required, ensure that qualified people use replacement parts specified by Rosemount. Unauthorized parts and procedures can affect the product's performance, place the safe operation of your process at risk, **and VOID YOUR WARRANTY.** Look-alike substitutions may result in fire, electrical hazards, or improper operation.
- **Ensure that all equipment doors are closed and protective covers are in place, except when maintenance is being performed by qualified persons, to prevent electrical shock and personal injury.**

The information contained in this document is subject to change without notice.

Emerson Process Management

Rosemount Analytical Inc. Process Analytic Division

1201 N. Main St.

Orrville, OH 44667-0901

T (330) 682-9010

F (330) 684-4434

e-mail: gas.csc@EmersonProcess.com

<http://www.processanalytic.com>



HIGHLIGHTS OF CHANGES

Effective April, 2001 Rev. 1

PAGE	SUMMARY
Throughout	Added identity of DVC6000 series digital valve controller where applicable.
1-0	Reidentified digital valve controllers; deleted cam codes in Product Matrix.
1-2	Added new actuator operation paragraph and illustration for HART versions using DVC6020 model valve controller.
1-3	Updated actuator operation paragraph and illustration for FIELDBUS versions using DVC5020f model valve controller.
1-4	Added paragraph 1-5 to reference valve controller specifications.
1-5 and 1-6	Deleted Table 1-3, DVC5000 valve controller specifications and moved balance of Section I text forward.
2-3	Updated Figure 2-5 to include DVC6000 valve controller identity.
2-4	Updated Figure 2-6 to include dampers.
4-1/4-2	Revised paragraph 4-1 to confine instructions to DVC5000 versions only.
5-1/5-2	Revised paragraph 5-1 to reference valve controller manuals for troubleshooting and include new actuator piping diagram (Figure 5-1) for HART versions using DVC6020 model valve controller. Revised piping diagram (Figure 5-2) for FIELDBUS versions to save vertical space. Deleted paragraph 5-2 and Table 5-1.
7-8	Added new paragraph 7-8 and Figure 7-4; replacement of DVC6000 electronic unit.
8-4 through 8-6	Added new text of paragraph 8-4, HART Site Programmable Alarm applicable to the DVC6000 series controller.
I-1/I-2	Updated index.
Appendix B	Added new Appendix B; retrofit instructions to incorporate DVC6000 electronic unit.

Effective November, 2001 Rev. 1.1

PAGE	SUMMARY
1-0	Revised Model Number Matrix.
Appendix A	Included revised Appendix A, rev. 1.0.

HIGHLIGHTS OF CHANGES APPENDIX A

Effective November, 2001 Rev. 1.0

Page	Summary
iii	Added new Model Number Matrix, Table A-1.
iv	Relocated Figure A-1 from page A-0 to page iv.

HIGHLIGHTS OF CHANGES APPENDIX B

Effective November, 2001 Rev. 1.0

Page	Summary
iii	Added new Model Number Matrix, Table B-1.
iv	Relocated Figure B-1 from page B-0 to page iv.

PURPOSE

The purpose of this manual is to provide a comprehensive understanding of the PowerVUE Fan/Damper Actuator components, functions, installation, and maintenance.

This manual is designed to provide information about the PowerVUE Fan/Damper Actuator. We recommend that you thoroughly familiarize yourself with the Description and Installation sections before installing your actuator.

The description presents the basic principles of the actuator along with its performance characteristics and components. The remaining sections contain detailed procedures and information necessary to install and service the actuator.

Before contacting Rosemount concerning any questions, first consult this manual. It describes most situations encountered in your equipment's operation and details necessary action.

DEFINITIONS

The following definitions apply to WARNINGS, CAUTIONS, and NOTES found throughout this publication.

WARNING

Highlights an operation or maintenance procedure, practice, condition, statement, etc. If not strictly observed, could result in injury, death, or long-term health hazards of personnel.

CAUTION

Highlights an operation or maintenance procedure, practice, condition, statement, etc. If not strictly observed, could result in damage to or destruction of equipment, or loss of effectiveness.

NOTE

Highlights an essential operating procedure, condition, or statement.

⊕ : EARTH (GROUND) TERMINAL

⊕ : PROTECTIVE CONDUCTOR TERMINAL

⚠ : RISK OF ELECTRICAL SHOCK

⚠ : WARNING: REFER TO INSTRUCTION BULLETIN



NOTE TO USERS

The number in the lower right corner of each illustration in this publication is a manual illustration number. It is not a part number, and is not related to the illustration in any technical manner.

IMPORTANT

SAFETY INSTRUCTIONS FOR THE WIRING AND INSTALLATION OF THIS APPARATUS



The following safety instructions apply specifically to all EU member states. They should be strictly adhered to in order to assure compliance with the Low Voltage Directive. Non-EU states should also comply with the following unless superseded by local or National Standards.

1. Adequate earth connections should be made to all earthing points, internal and external, where provided.
2. After installation or troubleshooting, all safety covers and safety grounds must be replaced. The integrity of all earth terminals must be maintained at all times.
3. Mains supply cords should comply with the requirements of IEC227 or IEC245.
4. All wiring shall be suitable for use in an ambient temperature of greater than 75°C.
5. All cable glands used should be of such internal dimensions as to provide adequate cable anchorage.
6. To ensure safe operation of this equipment, connection to the mains supply should only be made through a circuit breaker which will disconnect all circuits carrying conductors during a fault situation. The circuit breaker may also include a mechanically operated isolating switch. If not, then another means of disconnecting the equipment from the supply must be provided and clearly marked as such. Circuit breakers or switches must comply with a recognized standard such as IEC947. All wiring must conform with any local standards.
7. Where equipment or covers are marked with the symbol to the right, hazardous voltages are likely to be present beneath. These covers should only be removed when power is removed from the equipment — and then only by trained service personnel.

8. Where equipment or covers are marked with the symbol to the right, there is a danger from hot surfaces beneath. These covers should only be removed by trained service personnel when power is removed from the equipment. Certain surfaces may remain hot to the touch.

9. Where equipment or covers are marked with the symbol to the right, refer to the Operator Manual for instructions.

10. All graphical symbols used in this product are from one or more of the following standards: EN61010-1, IEC417, and ISO3864.

BELANGRIJK

Veiligheidsvoorschriften voor de aansluiting en installatie van dit toestel.



De hierna volgende veiligheidsvoorschriften zijn vooral bedoeld voor de EU lidstaten. Hier moet aan gehouden worden om de onderworpenheid aan de Laag Spannings Richtlijn (Low Voltage Directive) te verzekeren. Niet EU staten zouden deze richtlijnen moeten volgen tenzij zij reeds achterhaald zouden zijn door plaatselijke of nationale voorschriften.

1. Degelijke aardingsaansluitingen moeten gemaakt worden naar alle voorziene aardpunten, intern en extern.
2. Na installatie of controle moeten alle veiligheidsdeksels en -aardingen terug geplaatst worden. Ten alle tijde moet de betrouwbaarheid van de aarding behouden blijven.
3. Voedingskabels moeten onderworpen zijn aan de IEC227 of de IEC245 voorschriften.
4. Alle bekabeling moet geschikt zijn voor het gebruik in omgevingstemperaturen, hoger dan 75°C.
5. Alle wartels moeten zo gedimensioneerd zijn dat een degelijke kabel bevestiging verzekerd is.
6. Om de veilige werking van dit toestel te verzekeren, moet de voeding door een stroomonderbreker gevoerd worden (min 10A) welke alle draden van de voeding moet onderbreken. De stroomonderbreker mag een mechanische schakelaar bevatten. Zoniet moet een andere mogelijkheid bestaan om de voedingsspanning van het toestel te halen en ook duidelijk zo zijn aangegeven. Stroomonderbrekers of schakelaars moeten onderworpen zijn aan een erkende standaard zoals IEC947.
7. Waar toestellen of deksels aangegeven staan met het symbool is er meestal hoogspanning aanwezig. Deze deksels mogen enkel verwijderd worden nadat de voedingsspanning werd afgelegd en enkel door getraind onderhoudspersoneel. 
8. Waar toestellen of deksels aangegeven staan met het symbool is er gevaar voor hete oppervlakken. Deze deksels mogen enkel verwijderd worden door getraind onderhoudspersoneel nadat de voedingsspanning verwijderd werd. Sommige oppervlakken kunnen 45 minuten later nog steeds heet aanvoelen. 
9. Waar toestellen of deksels aangegeven staan met het symbool gelieve het handboek te raadplegen. 
10. Alle grafische symbolen gebruikt in dit produkt, zijn afkomstig uit een of meer van devolgende standaards: EN61010-1, IEC417 en ISO3864.

VIGTIGT

Sikkerhedsinstruktion for tilslutning og installation af dette udstyr.



Følgende sikkerhedsinstruktioner gælder specifikt i alle EU-medlemslande. Instruktionerne skal nøje følges for overholdelse af Lavspændingsdirektivet og bør også følges i ikke EU-lande medmindre andet er specificeret af lokale eller nationale standarder.

1. Passende jordforbindelser skal tilsluttes alle jordklemmer, interne og eksterne, hvor disse forefindes.
2. Efter installation eller fejlfinding skal alle sikkerhedsdæksler og jordforbindelser reetableres.
3. Forsyningskabler skal opfylde krav specificeret i IEC227 eller IEC245.
4. Alle ledningstilslutninger skal være konstrueret til omgivelsestemperatur højere end 75° C.
5. Alle benyttede kabelforskrutninger skal have en intern dimension, så passende kabelafslutning kan etableres.
6. For opnåelse af sikker drift og betjening skal der skabes beskyttelse mod indirekte berøring gennem afbryder (min. 10A), som vil afbryde alle kredsløb med elektriske ledere i fejlsituation. Afbryderen skal indholde en mekanisk betjent kontakt. Hvis ikke skal anden form for afbryder mellem forsyning og udstyr benyttes og mærkes som sådan. Afbrydere eller kontakter skal overholde en kendt standard som IEC947.
7. Hvor udstyr eller dæksler er mærket med dette symbol, er farlige spændinger normalt forekommende bagved. Disse dæksler bør kun afmonteres, når forsyningsspændingen er frakoblet - og da kun af instrueret servicepersonale. 
8. Hvor udstyr eller dæksler er mærket med dette symbol, forefindes meget varme overflader bagved. Disse dæksler bør kun afmonteres af instrueret servicepersonale, når forsyningsspænding er frakoblet. Visse overflader vil stadig være for varme at berøre i op til 45 minutter efter frakobling. 
9. Hvor udstyr eller dæksler er mærket med dette symbol, se da i betjeningsmanual for instruktion. 
10. Alle benyttede grafiske symboler i dette udstyr findes i én eller flere af følgende standarder:- EN61010-1, IEC417 & ISO3864.

BELANGRIJK

Veiligheidsinstructies voor de bedrading en installatie van dit apparaat.



Voor alle EU lidstaten zijn de volgende veiligheidsinstructies van toepassing. Om aan de geldende richtlijnen voor laagspanning te voldoen dient men zich hieraan strikt te houden. Ook niet EU lidstaten dienen zich aan het volgende te houden, tenzij de lokale wetgeving anders voorschrijft.

1. Alle voorziene interne- en externe aardaansluitingen dienen op adequate wijze aangesloten te worden.
2. Na installatie, onderhouds- of reparatie werkzaamheden dienen alle beschermdeksels /kappen en aardingen om reden van veiligheid weer aangebracht te worden.
3. Voedingskabels dienen te voldoen aan de vereisten van de normen IEC 227 of IEC 245.
4. Alle bedrading dient geschikt te zijn voor gebruik bij een omgevings temperatuur boven 75°C.
5. Alle gebruikte kabelwartels dienen dusdanige inwendige afmetingen te hebben dat een adequate verankering van de kabel wordt verkregen.
6. Om een veilige werking van de apparatuur te waarborgen dient de voeding uitsluitend plaats te vinden via een meerpolige automatische zekering (min.10A) die **alle** spanningvoerende geleiders verbreekt indien een foutconditie optreedt. Deze automatische zekering mag ook voorzien zijn van een mechanisch bediende schakelaar. Bij het ontbreken van deze voorziening dient een andere als zodanig duidelijk aangegeven mogelijkheid aanwezig te zijn om de spanning van de apparatuur af te schakelen. Zekeringen en schakelaars dienen te voldoen aan een erkende standaard zoals IEC 947.
7. Waar de apparatuur of de beschermdeksels/kappen gemarkeerd zijn met het volgende symbool, kunnen zich hieronder spanning voerende delen bevinden die gevaar op kunnen leveren. Deze beschermdeksels/kappen mogen uitsluitend verwijderd worden door getraind personeel als de spanning is afgeschakeld. 
8. Waar de apparatuur of de beschermdeksels/kappen gemarkeerd zijn met het volgende symbool, kunnen zich hieronder hete oppervlakken of onderdelen bevinden. Bepaalde delen kunnen mogelijk na 45 min. nog te heet zijn om aan te raken. 
9. Waar de apparatuur of de beschermdeksels/kappen gemarkeerd zijn met het volgende symbool, dient men de bedieningshandleiding te raadplegen. 
10. Alle grafische symbolen gebruikt bij dit produkt zijn volgens een of meer van de volgende standaarden: EN 61010-1, IEC 417 & ISO 3864.

TÄRKEÄÄ

Turvallisuusohje, jota on noudatettava tämän laitteen asentamisessa ja kaapeloinnissa.



Seuraavat ohjeet pätevät erityisesti EU:n jäsenvaltioissa. Niitä täytyy ehdottomasti noudattaa jotta täytettäisiin EU:n matalajännittdirektiivin (Low Voltage Directive) yhteensopivuus. Myös EU:hun kuulumattomien valtioiden tulee noudattaa tätä ohjetta, elleivät kansalliset standardit estä sitä.

1. Riittävät maadoituskytkennät on tehtävä kaikkiin maadoituspisteisiin, sisäisiin ja ulkoisiin.
2. Asennuksen ja vianetsinnän jälkeen on kaikki suojat ja suojamaat asennettava takaisin paikoilleen. Maadoitusliittimen kunnollinen toiminta täytyy aina ylläpitää.
3. Jännitesyöttöjohtimien täytyy täyttää IEC227 ja IEC245 vaatimukset.
4. Kaikkien johdotuksien tulee toimia $>75^{\circ}\text{C}$ lämpötiloissa.
5. Kaikkien läpivientiholkkien sisähalkaisijan täytyy olla sellainen että kaapeli lukkiutuu kunnolla kiinni.
6. Turvallisen toiminnan varmistamiseksi täytyy jännitesyöttö varustaa turvakytkimellä (min 10A), joka kytkee irti kaikki jännitesyöttöjohtimet vikatilanteessa. Suojaan täytyy myös sisältyä mekaaninen erotuskytkin. Jos ei, niin jännitesyöttö on pystyttävä katkaisemaan muilla keinoilla ja merkittävä siten että se tunnistetaan sellaiseksi. Turvakytkimien tai katkaisimien täytyy täyttää IEC947 standardin vaatimukset näkyvyydestä.
7. Mikäli laite tai kosketussuoja on merkitty tällä merkillä on merkinnän takana tai alla hengenvaarallisen suuruinen jännite. Suojaa ei saa poistaa jänniteen ollessa kytkettynä laitteeseen ja poistamisen saa suorittaa vain alan asiantuntija. 
8. Mikäli laite tai kosketussuoja on merkitty tällä merkillä on merkinnän takana tai alla kuuma pinta. Suojan saa poistaa vain alan asiantuntija kun jännite-syöttö on katkaistu. Tällainen pinta voi säilyä kosketuskuumana jopa 45 mi-nuuttia. 
9. Mikäli laite tai kosketussuoja on merkitty tällä merkillä katso lisäohjeita käyt-töohjekirjasta 
10. Kaikki tässä tuotteessa käytetyt graafiset symbolit ovat yhdestä tai useammasta seuraavista standardeista: EN61010-1, IEC417 & ISO3864.

IMPORTANT

Consignes de sécurité concernant le raccordement et l'installation de cet appareil.



Les consignes de sécurité ci-dessous s'adressent particulièrement à tous les états membres de la communauté européenne. Elles doivent être strictement appliquées afin de satisfaire aux directives concernant la basse tension. Les états non membres de la communauté européenne doivent également appliquer ces consignes sauf si elles sont en contradiction avec les standards locaux ou nationaux.

1. Un raccordement adéquat à la terre doit être effectuée à chaque borne de mise à la terre, interne et externe.
2. Après installation ou dépannage, tous les capots de protection et toutes les prises de terre doivent être remis en place, toutes les prises de terre doivent être respectées en permanence.
3. Les câbles d'alimentation électrique doivent être conformes aux normes IEC227 ou IEC245
4. Tous les raccordements doivent pouvoir supporter une température ambiante supérieure à 75°C.
5. Tous les presse-étoupes utilisés doivent avoir un diamètre interne en rapport avec les câbles afin d'assurer un serrage correct sur ces derniers.
6. Afin de garantir la sécurité du fonctionnement de cet appareil, le raccordement à l'alimentation électrique doit être réalisé exclusivement au travers d'un disjoncteur (minimum 10A.) isolant tous les conducteurs en cas d'anomalie. Ce disjoncteur doit également pouvoir être actionné manuellement, de façon mécanique. Dans le cas contraire, un autre système doit être mis en place afin de pouvoir isoler l'appareil et doit être signalisé comme tel. Disjoncteurs et interrupteurs doivent être conformes à une norme reconnue telle IEC947.
7. Lorsque les équipements ou les capots affichent le symbole suivant, cela signifie que des tensions dangereuses sont présentes. Ces capots ne doivent être démontés que lorsque l'alimentation est coupée, et uniquement par un personnel compétent. 
8. Lorsque les équipements ou les capots affichent le symbole suivant, cela signifie que des surfaces dangereusement chaudes sont présentes. Ces capots ne doivent être démontés que lorsque l'alimentation est coupée, et uniquement par un personnel compétent. Certaines surfaces peuvent rester chaudes jusqu'à 45 mn. 
9. Lorsque les équipements ou les capots affichent le symbole suivant, se reporter au manuel d'instructions. 
10. Tous les symboles graphiques utilisés dans ce produit sont conformes à un ou plusieurs des standards suivants: EN61010-1, IEC417 & ISO3864.

WICHTIG

Sicherheitshinweise für den Anschluß und die Installation dieser Geräte.



Die folgenden Sicherheitshinweise sind in allen Mitgliederstaaten der europäischen Gemeinschaft gültig. Sie müssen strikt eingehalten werden, um der Niederspannungsrichtlinie zu genügen. Nichtmitgliedsstaaten der europäischen Gemeinschaft sollten die national gültigen Normen und Richtlinien einhalten.

1. Alle intern und extern vorgesehenen Erdungen der Geräte müssen ausgeführt werden.
2. Nach Installation, Reparatur oder sonstigen Eingriffen in das Gerät müssen alle Sicherheitssabdeckungen und Erdungen wieder installiert werden. Die Funktion aller Erdverbindungen darf zu keinem Zeitpunkt gestört sein.
3. Die Netzspannungsversorgung muß den Anforderungen der IEC227 oder IEC245 genügen.
4. Alle Verdrahtungen sollten mindestens bis 75 °C ihre Funktion dauerhaft erfüllen.
5. Alle Kabeldurchführungen und Kabelverschraubungen sollten in Ihrer Dimensionierung so gewählt werden, daß diese eine sichere Verkabelung des Gerätes ermöglichen.
6. Um eine sichere Funktion des Gerätes zu gewährleisten, muß die Spannungsversorgung über mindestens 10 A abgesichert sein. Im Fehlerfall muß dadurch gewährleistet sein, daß die Spannungsversorgung zum Gerät bzw. zu den Geräten unterbrochen wird. Ein mechanischer Schutzschalter kann in dieses System integriert werden. Falls eine derartige Vorrichtung nicht vorhanden ist, muß eine andere Möglichkeit zur Unterbrechung der Spannungszufuhr gewährleistet werden mit Hinweisen deutlich gekennzeichnet werden. Ein solcher Mechanismus zur Spannungsunterbrechung muß mit den Normen und Richtlinien für die allgemeine Installation von Elektrogeräten, wie zum Beispiel der IEC947, übereinstimmen.
7. Mit dem Symbol sind Geräte oder Abdeckungen gekennzeichnet, die eine gefährliche (Netzspannung) Spannung führen. Die Abdeckungen dürfen nur entfernt werden, wenn die Versorgungsspannung unterbrochen wurde. Nur geschultes Personal darf an diesen Geräten Arbeiten ausführen. 
8. Mit dem Symbol sind Geräte oder Abdeckungen gekennzeichnet, in bzw. unter denen heiße Teile vorhanden sind. Die Abdeckungen dürfen nur entfernt werden, wenn die Versorgungsspannung unterbrochen wurde. Nur geschultes Personal darf an diesen Geräten Arbeiten ausführen. Bis 45 Minuten nach dem Unterbrechen der Netzzufuhr können derartig Teile noch über eine erhöhte Temperatur verfügen. 
9. Mit dem Symbol sind Geräte oder Abdeckungen gekennzeichnet, bei denen vor dem Eingriff die entsprechenden Kapitel im Handbuch sorgfältig durchgelesen werden müssen. 
10. Alle in diesem Gerät verwendeten graphischen Symbole entspringen einem oder mehreren der nachfolgend aufgeführten Standards: EN61010-1, IEC417 & ISO3864.

IMPORTANTE

Norme di sicurezza per il cablaggio e l'installazione dello strumento.



Le seguenti norme di sicurezza si applicano specificatamente agli stati membri dell'Unione Europea, la cui stretta osservanza è richiesta per garantire conformità alla Direttiva del Basso Voltaggio. Esse si applicano anche agli stati non appartenenti all'Unione Europea, salvo quanto disposto dalle vigenti normative locali o nazionali.

1. Collegamenti di terra idonei devono essere eseguiti per tutti i punti di messa a terra interni ed esterni, dove previsti.
2. Dopo l'installazione o la localizzazione dei guasti, assicurarsi che tutti i coperchi di protezione siano stati collocati e le messa a terra siano collegate. L'integrità di ciascun morsetto di terra deve essere costantemente garantita.
3. I cavi di alimentazione della rete devono essere secondo disposizioni IEC227 o IEC245.
4. L'intero impianto elettrico deve essere adatto per uso in ambiente con temperature superiore a 75°C.
5. Le dimensioni di tutti i connettori dei cavi utilizzati devono essere tali da consentire un adeguato ancoraggio al cavo.
6. Per garantire un sicuro funzionamento dello strumento il collegamento alla rete di alimentazione principale dovrà essere eseguita tramite interruttore automatico (min.10A), in grado di disattivare tutti i conduttori di circuito in caso di guasto. Tale interruttore dovrà inoltre prevedere un sezionatore manuale o altro dispositivo di interruzione dell'alimentazione, chiaramente identificabile. Gli interruttori dovranno essere conformi agli standard riconosciuti, quali IEC947.
7. Il simbolo riportato sullo strumento o sui coperchi di protezione indica probabile presenza di elevati voltaggi. Tali coperchi di protezione devono essere rimossi esclusivamente da personale qualificato, dopo aver tolto alimentazione allo strumento. 
8. Il simbolo riportato sullo strumento o sui coperchi di protezione indica rischio di contatto con superfici ad alta temperatura. Tali coperchi di protezione devono essere rimossi esclusivamente da personale qualificato, dopo aver tolto alimentazione allo strumento. Alcune superfici possono mantenere temperature elevate per oltre 45 minuti. 
9. Se lo strumento o il coperchio di protezione riportano il simbolo, fare riferimento alle istruzioni del manuale Operatore. 
10. Tutti i simboli grafici utilizzati in questo prodotto sono previsti da uno o più dei seguenti standard: EN61010-1, IEC417 e ISO3864.

VIKTIG

Sikkerhetsinstruks for tilkobling og installasjon av dette utstyret.



Følgende sikkerhetsinstruksjoner gjelder spesifikt alle EU medlemsland og land med i EØS-avtalen. Instruksjonene skal følges nøye slik at installasjonen blir i henhold til lavspenningsdirektivet. Den bør også følges i andre land, med mindre annet er spesifisert av lokale- eller nasjonale standarder.

1. Passende jordforbindelser må tilkobles alle jordingspunkter, interne og eksterne hvor disse forefinnes.
2. Etter installasjon eller feilsøking skal alle sikkerhetsdeksler og jordforbindelser reetableres. Jordingsforbindelsene må alltid holdes i god stand.
3. Kabler fra spenningsforsyning skal oppfylle kravene spesifisert i IEC227 eller IEC245.
4. Alle ledningsforbindelser skal være konstruert for en omgivelsestemperatur høyere en 750C.
5. Alle kabelforskrivninger som benyttes skal ha en indre dimensjon slik at tilstrekkelig avlastning oppnåes.
6. For å oppnå sikker drift og betjening skal forbindelsen til spenningsforsyningen bare skje gjennom en strømbryter (minimum 10A) som vil bryte spenningsforsyningen til alle elektriske kretser ved en feilsituasjon. Strømbryteren kan også inneholde en mekanisk operert bryter for å isolere instrumentet fra spenningsforsyningen. Dersom det ikke er en mekanisk operert bryter installert, må det være en annen måte å isolere utstyret fra spenningsforsyningen, og denne måten må være tydelig merket. Kretsbytere eller kontakter skal oppfylle kravene i en annerkjent standard av typen IEC947 eller tilsvarende.
7. Der hvor utstyr eller deksler er merket med symbol for farlig spenning, er det sannsynlig at disse er tilstede bak dekslet. Disse dekslene må bare fjernes når spenningsforsyning er frakoblet utstyret, og da bare av trenet servicepersonell. 
8. Der hvor utstyr eller deksler er merket med symbol for meget varm overflate, er det sannsynlig at disse er tilstede bak dekslet. Disse dekslene må bare fjernes når spenningsforsyning er frakoblet utstyret, og da bare av trenet servicepersonell. Noen overflater kan være for varme til å berøres i opp til 45 minutter etter spenningsforsyning frakoblet. 
9. Der hvor utstyret eller deksler er merket med symbol, vennligst referer til instruksjonsmanualen for instruksjer. 
10. Alle grafiske symboler brukt i dette produktet er fra en eller flere av følgende standarder: EN61010-1, IEC417 & ISO3864.

IMPORTANTE

Instruções de segurança para ligação e instalação deste aparelho.



As seguintes instruções de segurança aplicam-se especificamente a todos os estados membros da UE. Devem ser observadas rigidamente por forma a garantir o cumprimento da Directiva sobre Baixa Tensão. Relativamente aos estados que não pertençam à UE, deverão cumprir igualmente a referida directiva, exceptuando os casos em que a legislação local a tiver substituído.

1. Devem ser feitas ligações de terra apropriadas a todos os pontos de terra, internos ou externos.
2. Após a instalação ou eventual reparação, devem ser recolocadas todas as tampas de segurança e terras de protecção. Deve manter-se sempre a integridade de todos os terminais de terra.
3. Os cabos de alimentação eléctrica devem obedecer às exigências das normas IEC227 ou IEC245.
4. Os cabos e fios utilizados nas ligações eléctricas devem ser adequados para utilização a uma temperatura ambiente até 75° C.
5. As dimensões internas dos buçins dos cabos devem ser adequadas a uma boa fixação dos cabos.
6. Para assegurar um funcionamento seguro deste equipamento, a ligação ao cabo de alimentação eléctrica deve ser feita através de um disjuntor (min. 10A) que desligará todos os condutores de circuitos durante uma avaria. O disjuntor poderá também conter um interruptor de isolamento accionado manualmente. Caso contrário, deverá ser instalado qualquer outro meio para desligar o equipamento da energia eléctrica, devendo ser assinalado convenientemente. Os disjuntores ou interruptores devem obedecer a uma norma reconhecida, tipo IEC947.
7. Sempre que o equipamento ou as tampas contiverem o símbolo, é provável a existência de tensões perigosas. Estas tampas só devem ser retiradas quando a energia eléctrica tiver sido desligada e por Pessoal da Assistência devidamente treinado. 
8. Sempre que o equipamento ou as tampas contiverem o símbolo, há perigo de existência de superfícies quentes. Estas tampas só devem ser retiradas por Pessoal da Assistência devidamente treinado e depois de a energia eléctrica ter sido desligada. Algumas superfícies permanecem quentes até 45 minutos depois. 
9. Sempre que o equipamento ou as tampas contiverem o símbolo, o Manual de Funcionamento deve ser consultado para obtenção das necessárias instruções. 
10. Todos os símbolos gráficos utilizados neste produto baseiam-se em uma ou mais das seguintes normas: EN61010-1, IEC417 e ISO3864.

IMPORTANTE

Instrucciones de seguridad para el montaje y cableado de este aparato.



Las siguientes instrucciones de seguridad , son de aplicacion especifica a todos los miembros de la UE y se adjuntaran para cumplir la normativa europea de baja tension.

1. Se deben preveer conexiones a tierra del equipo, tanto externa como internamente, en aquellos terminales previstos al efecto.
2. Una vez finalizada las operaciones de mantenimiento del equipo, se deben volver a colocar las cubiertas de seguridad aasi como los terminales de tierra. Se debe comprobar la integridad de cada terminal.
3. Los cables de alimentacion electrica cumpliran con las normas IEC 227 o IEC 245.
4. Todo el cableado sera adecuado para una temperatura ambiental de 75°C.
5. Todos los prensaestopas seran adecuados para una fijacion adecuada de los cables.
6. Para un manejo seguro del equipo, la alimentacion electrica se realizara a traves de un interruptor magnetotermico (min 10 A), el cual desconectara la alimentacion electrica al equipo en todas sus fases durante un fallo. Los interruptores estaran de acuerdo a la norma IEC 947 u otra de reconocido prestigio.
7. Cuando las tapas o el equipo lleve impreso el simbolo de tension electrica peligrosa, dicho alojamiento solamente se abra una vez que se haya interrumpido la alimentacion electrica al equipo asimismo la intervencion sera llevada a cabo por personal entrenado para estas labores. 
8. Cuando las tapas o el equipo lleve impreso el simbolo, hay superficies con alta temperatura, por tanto se abra una vez que se haya interrumpido la alimentacion electrica al equipo por personal entrenado para estas labores, y al menos se esperara unos 45 minutos para enfriar las superficies calientes. 
9. Cuando el equipo o la tapa lleve impreso el simbolo, se consultara el manual de instrucciones. 
10. Todos los simbolos graficos usados en esta hoja, estan de acuerdo a las siguientes normas EN61010-1, IEC417 & ISO 3864.

VIKTIGT

Säkerhetsföreskrifter för kablage och installation av denna apparat.

Följande säkerhetsföreskrifter är tillämpliga för samtliga EU-medlemsländer. De skall följas i varje avseende för att överensstämja med Lågspännings direktivet. Icke EU medlemsländer skall också följa nedanstående punkter, såvida de inte övergrips av lokala eller nationella föreskrifter.

1. Tillämplig jordkontakt skall utföras till alla jordade punkter, såväl internt som externt där så erfordras.
2. Efter installation eller felsökning skall samtliga säkerhetshöljen och säkerhetsjord återplaceras. Samtliga jordterminaler måste hållas obrutna hela tiden.
3. Matningsspänningens kabel måste överensstämja med föreskrifterna i IEC227 eller IEC245.
4. Allt kablage skall vara lämpligt för användning i en omgivningstemperatur högre än 75°C.
5. Alla kabelförskruvningar som används skall ha inre dimensioner som motsvarar adekvat kabelförankring.
6. För att säkerställa säker drift av denna utrustning skall anslutning till huvudströmmen endast göras genom en säkring (min 10A) som skall frångöras alla strömförande kretsar när något fel uppstår. Säkringen kan även ha en mekanisk frångörare. Om så inte är fallet, måste ett annat förfarande för att frångöra utrustningen från strömförsörjning tillhandahållas och klart framgå genom markering. Säkring eller omkopplare måste överensstämja med en gällande standard såsom t ex IEC947.
7. Där utrustning eller hölje är markerad med vidstående symbol föreligger risk för livsfarlig spänning i närheten. Dessa höljen får endast avlägsnas när strömmen ej är ansluten till utrustningen - och då endast av utbildad servicepersonal. 
8. När utrustning eller hölje är markerad med vidstående symbol föreligger risk för brännskada vid kontakt med uppvärmd yta. Dessa höljen får endast avlägsnas av utbildad servicepersonal, när strömmen kopplats från utrustningen. Vissa ytor kan vara mycket varma att vidröra även upp till 45 minuter efter avstängning av strömmen. 
9. När utrustning eller hölje markerats med vidstående symbol bör instruktionsmanualen studeras för information. 
10. Samtliga grafiska symboler som förekommer i denna produkt finns angivna i en eller flera av följande föreskrifter:- EN61010-1, IEC417 & ISO3864.

ΠΡΟΣΟΧΗ

Οδηγίες ασφαλείας για την καλωδίωση και εγκατάσταση της συσκευής.

Οι ακόλουθες οδηγίες ασφαλείας εφαρμόζονται ειδικά σε όλες τις χώρες μέλη της Ευρωπαϊκής Κοινότητας. Θα πρέπει να ακολουθούνται αυστηρά ώστε να εξασφαλιστεί η συμβατότητα με τις οδηγίες για τη Χαμηλή Τάση. Χώρες που δεν είναι μέλη της Ευρωπαϊκής Κοινότητας θα πρέπει επίσης να ακολουθούν τις οδηγίες εκτός εάν αντικαθίστανται από τα Τοπικά ή Εθνικά Πρότυπα.



1. Επαρκείς συνδέσεις γείωσης θα πρέπει να γίνονται σε όλα τα σημεία γείωσης, εσωτερικά και εξωτερικά όπου υπάρχουν.
2. Μετά την εγκατάσταση ή την εκσφαλμάτωση όλα τα καλύματα ασφαλείας και οι γειώσεις ασφαλείας πρέπει να επανεγκαθίστανται. Η καλή κατάσταση όλων των ακροδεκτών γείωσης πρέπει να ελέγχεται και να συντηρείται διαρκώς.
3. Τα καλώδια τροφοδοσίας πρέπει να πληρούν τις απαιτήσεις των IEC227 ή IEC245.
4. Όλες οι καλωδιώσεις θα πρέπει είναι κατάλληλες για χρήση σε ατμοσφαιρική θερμοκρασία χώρου υψηλότερη από 75°C.
5. Όλοι οι στυπιοθλίπτες θα πρέπει να είναι τέτοιων εσωτερικών διαστάσεων ώστε να παρέχουν επαρκή στερέωση των καλωδίων.
6. Για τη διασφάλιση ασφαλούς λειτουργίας της σύνδεσης τροφοδοσίας αυτής της συσκευής θα πρέπει να γίνεται μόνο μέσω ασφαλειοδιακόπτη (ελάχιστο 10A) ο οποίος θα αποσυνδέει όλους του ηλεκτροφόρους αγωγούς στη διάρκεια κατάστασης σφάλματος.
Ο ασφαλειοδιακόπτης μπορεί επίσης να περιλαμβάνει μηχανικό διακόπτη απομόνωσης. Εάν δεν περιλαμβάνει, τότε άλλα μέσα αποσύνδεσης της συσκευής από την τροφοδοσία πρέπει να παροχηθούν και σαφώς να σημειθούν σαν τέτοια. Οι ασφαλειοδιακόπτες ή διακόπτες πρέπει να συμφωνούν με αναγνωρισμένα πρότυπα όπως το IEC947.
7. Οπου συσκευές ή καλύματα είναι σημασμένα με το σύμβολο επικίνδυνες τάσεις ενυπάρχουν κάτω από αυτά.
Αυτά τα καλύματα θα πρέπει να αφαιρούνται μόνο όταν έχει αφαιρεθεί η τροφοδοσία από τη συσκευή και τότε μόνο από ειδικευμένο τεχνικό προσωπικό.
8. Οπου συσκευές ή καλύματα είναι σημασμένα με το σύμβολο υπάρχει κίνδυνος από καυτές επιφάνειες κάτω από αυτά.
Αυτά τα καλύματα θα πρέπει να αφαιρούνται μόνο από ειδικευμένο τεχνικό προσωπικό, όταν η τροφοδοσία έχει αφαιρεθεί από τη συσκευή. Τέτοιες επιφάνειες μπορούν να παραμείνουν ζεστές στην αφή έως και 45 λεπτά αργότερα.
9. Οπου συσκευές ή καλύματα είναι σημασμένα με το σύμβολο αναφερθείται στις οδηγίες χρήσης της συσκευής.
10. Όλα τα γραφικά σύμβολα που χρησιμοποιούνται σε αυτό το προϊόν είναι από ένα ή περισσότερα από τα έξης πρότυπα: EN61010-1, IEC417 και ISO3864.

TABLE OF CONTENTS

Section	Page
I. DESCRIPTION.....	1-1
1-1. Component Checklist of Typical System (Package Contents).....	1-1
1-2. Model Number Matrix.....	1-1
1-3. System Overview.....	1-1
1-4. Model PVD 814 Specifications.....	1-4
1-5. Controller Specifications.....	1-4
1-6. Storage Instructions.....	1-6
II. INSTALLATION.....	2-1
2-1. Overview.....	2-1
2-2. Special Installation Considerations.....	2-1
2-3. Actuator Mounting Instructions.....	2-2
2-4. Air Supply Installation.....	2-3
2-5. Linkage Installation.....	2-4
III. DVC5000/6000 ELECTRONICS SETUP.....	3-1
3-1. Introduction.....	3-1
IV. STARTUP CALIBRATION.....	4-1
4-1. Reverse Relay Calibration (DVC5000 only).....	4-1
4-2. DVC5000/6000 Calibration.....	4-1
V. TROUBLESHOOTING.....	5-1
5-1. Overview.....	5-1
VI. PERIODIC MAINTENANCE.....	6-1
6-1. Overview.....	6-1
6-2. Maintenance Schedule.....	6-1
6-3. General Cleaning and Lubrication.....	6-1
6-4. Cylinder and Piston Cleaning and Lubrication.....	6-2
6-5. Air Lock Adjustment.....	6-4
6-6. Mechanical Linkage Cleaning and Lubrication.....	6-4
VII. CORRECTIVE MAINTENANCE.....	7-1
7-1. Overview.....	7-1
7-2. Cylinder Head Gaskets, Piston, and Rod Packing.....	7-1
7-3. Cylinder Replacement.....	7-3
7-4. Air Lock Diaphragm.....	7-4
7-5. Transfer Valve.....	7-4
7-6. Reverse Relay.....	7-6
7-7. DVC5000 Electronic Unit.....	7-7
7-8. DVC6000 Electronic Unit.....	7-8
7-9. Shaft Bushings.....	7-9

Section	Page
VIII. OPTIONS.....	8-1
8-1. Overview.....	8-1
8-2. Limit Switches	8-1
8-3. Heater/Thermostat.....	8-3
8-4. HART Site Programmable Alarm (DVC6000 Series Controller only).....	8-4
IX. RECOMMENDED SPARE PARTS.....	9-1
X. RETURNING EQUIPMENT TO THE FACTORY	10-1
 INDEX	
 APPENDIX A. RETROFIT KIT INSTALLATION INSTRUCTIONS for use with DVC5000 Series DIGITAL VALVE CONTROLLER	
 APPENDIX B. RETROFIT KIT INSTALLATION INSTRUCTIONS for use with DVC6000 Series DIGITAL VALVE CONTROLLER	

LIST OF ILLUSTRATIONS

Figure		Page
1-1	Typical System Package	1-1
1-2	Actuator Operation Diagram - HART Versions using DVC6020	1-3
1-3	Actuator Operation Diagram - FOUNDATION Fieldbus Versions using DVC5020f	1-3
1-4	Typical Actuator Installation	1-4
2-1	Angular Relationship of Drive and Driven Arms	2-1
2-2	Clearance Requirements	2-2
2-3	Actuator Unit Mounting and Installation (Footprint) Drawing	2-2
2-4	8 x 14 Actuator Torque Chart	2-3
2-5	Air Piping Schematic	2-3
2-6	Linkage Installation	2-4
4-1	Reverse Relay Calibration	4-1
5-1	Actuator Air Piping Diagram - HART Versions using DVC6020	5-1
5-2	Actuator Air Piping Diagram - FOUNDATION Fieldbus Versions using DVC5020f	5-1
6-1	Lubrication Chart	6-0
6-2	Cylinder Exploded View	6-3
6-3	Air Lock Diaphragm	6-4
6-4	Mechanical Linkage	6-5
7-1	Cylinder Exploded View	7-2
7-2	Mechanical Air Lock and Transfer Valve	7-5
7-3	Reverse Relay and DVC5000 Electronic Unit Replacement	7-6
7-4	DVC6000 Electronic Unit Replacement	7-8
7-5	Shaft Exploded View	7-9
8-1	Limit Switch Exploded View	8-2
8-2	Heater/Thermostat	8-3
8-3	Timing Chart for Flame Safety Application	8-6
8-4	Wiring Diagram for Flame Safety Application	8-6

LIST OF TABLES

Table		Page
1-1	Model Number Matrix	1-0
1-2	Specifications for Model PVD 814 Actuator	1-5
1-3	Specifications for Recommended Rust Preventative Compound	1-6
6-1	Maintenance Schedule	6-1
9-1	Recommended Spare Parts for PowerVUE Model PVD 814 Fan/Damper Actuator	9-1
9-2	Recommended Spare Parts for Options (PowerVUE Model PVD 814 Fan/Damper Actuator Only)	9-2

Table 1-1. Model Number Matrix

8 x 14 TORQUE TYPE FLOOR MOUNTED - ORDERING INFORMATION

Select complete model number from the Model Number Matrix.

PVD 814	PowerVUE Drive					
	Code	Basic Assembly Type and Connection Material				
	01	Standard Brass Assembly				
	02	Standard Stainless Assembly				
	03	Mechanical Air Lock Brass Assembly				
	04	Mechanical Air Lock Stainless Assembly				
	Code	Digital Valve Controller				
	00	None ⁽¹⁾				
	01	HART ⁽²⁾ DVC6000				
	02	Fieldbus ⁽³⁾ DVC5020f, including Basic Control Suite				
	03	Fieldbus ⁽³⁾ DVC5000f, without Basic Control Suite				
	04	Other DVC Style Selected ⁽⁴⁾				
	Code	Limit Switches				
	01	None				
	02	2 Std. Limit Switch – SPDT				
	Code	EPT				
	01	None				
	02	Digital EPT and 2 Limit Contacts (HART versions only) ⁽⁵⁾				
	Code	Heater Option				
	01	None				
	02	Heater/Thermostat 115VAC 150 Watt (Not for use in hazardous areas)				
PVD 814	01	02	01	01	02	EXAMPLE

NOTES:

- Digital Valve Controller (DVC5000/6000) may be supplied by others, but no performance quarantees for accuracy or speeds of response are provided. Warranty for DVC5000/6000 will be the responsibility of the provider. Tubing is provided, but is not precut or preformed.
- Standard arrangement calls for Model DVC6020-516G60, certified to FM as intrinsically safe, and Division 2. Other certifications available. Advanced diagnostics provided.
- Standard arrangement calls for Model DVC5020f-216, certified to FM as intrinsically safe, and Division 2. Other certifications are available. Advanced diagnostics provided.
- Designate other DVC5000 model number as a note on order.
- Alarm.

Default configuration:

- 1 analog output representing actuator travel
- 3 customer selectable position contacts
- 1 contact for Field Device Failure

Moore HART SPA may be configured in an intrinsically safe arrangement through an IS barrier.

DVC5000/6000 Options:

- Flameproof cable gland: ½" NPT (aluminum), EExd IIC
- Cable entry adaptor (brass): ½" NPT M20 x 1.5 ISO

HART Filters

Filter Type	Option Number
HF210 (cage clamp – normal)	HF21N
HF210 (cage clamp – reversed)	HF21R
HF220 (screw terminal – normal)	HF22N
HF220 (screw terminal – reversed)	HF22R
HF230 (tiered terminal)	HF23
HF240 (DIN rail)	HF24D
HF240 (DIN rail – pass through – no filter)	HF24DP

SECTION I. DESCRIPTION

1-1. **COMPONENT CHECKLIST OF TYPICAL SYSTEM (PACKAGE CONTENTS).** A typical PowerVUE™ 8 x 14 fan/damper actuator package should contain the items shown in Figure 1-1.

1-2. **MODEL NUMBER MATRIX.** Use model number matrix, Table 1-1, to verify your style number. The first part of the matrix defines the model. The last part defines various options and features of the actuator. Copy the model number from the data plate located on the side of the actuator into the top of matrix Table 1-1. Check the model number against the actuator features and options, making sure options specified by this number are on the unit. Use this complete model number for any correspondence with Rosemount.

1-3. **SYSTEM OVERVIEW.**

a. **Scope.** This Instruction Bulletin supplies details needed to install, operate, and service the PowerVUE 8 x 14 fan/damper actuator.

The standard actuator includes FIELDVUE® DVC5000/6000 Series electronics, air lock

capability, transfer valve, supply air filter, clevis, and dust cover. Actuator options include digital electric position transmitter with 2 limit contacts (for HART versions only), limit switches, heater/thermostat, minimum limit stop, and a handwheel/hard mechanical air lock upon loss of plant air.

b. **Actuator Features.** The PowerVUE actuator is usually equipped with the following features:

1. The DVC5000/6000 electronic controller is a two-wire instrument and is certified intrinsically safe. It is available with either HART or FOUNDATION fieldbus communications.
2. An optional handwheel/hard mechanical air lock system provides a means of manually changing the position of the controlled device (such as dampers, control valves, and inlet vanes). In the event of plant air loss, continued operation of the actuator is made possible by the handwheel.

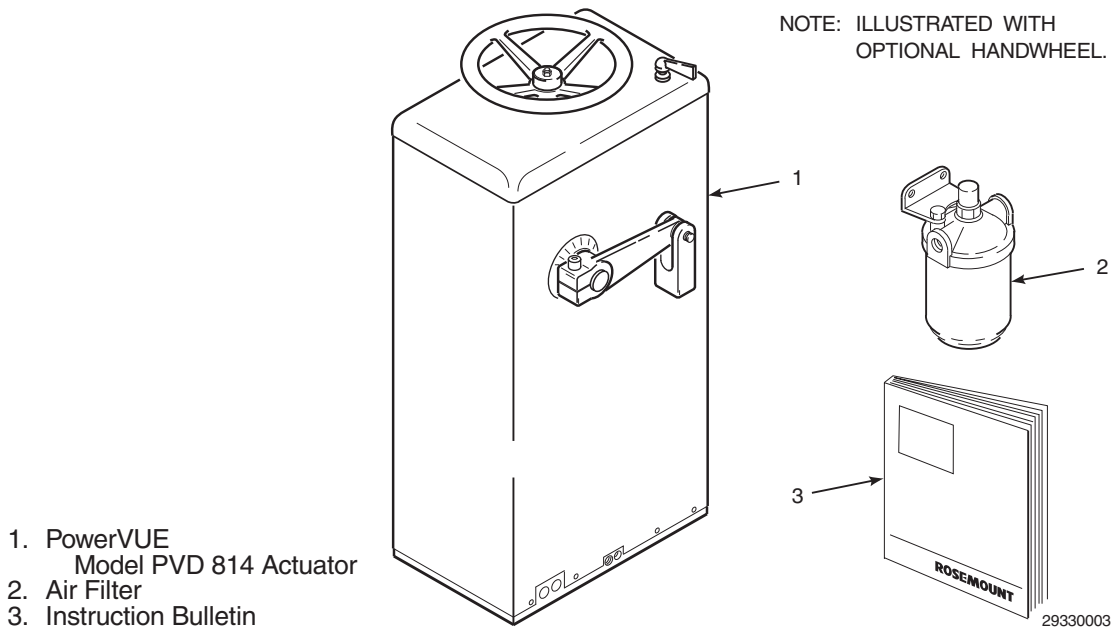

Figure 1-1. Typical System Package

Part of the option, a two-position transfer valve, allows simultaneous operation of the air lock, handwheel, and a pneumatic trip valve. In the manual position, the air lock and handwheel are engaged, and the trip switch opens a pneumatic bypass. In the automatic position, the air lock and handwheel are disengaged and the bypass is closed.

- (a) The air lock allows the operator to lock the piston and actuator shaft in any position. Moving the transfer valve to the manual position cuts off the air supply to the air lock diaphragms, allowing a fail-safe air lock to engage. When the transfer valve is in the automatic position, air pressure is returned to the diaphragms, causing the lock to disengage.
 - (b) Placing the transfer valve in manual, or a loss of plant air pressure, will cause the trip valve to activate the pneumatic bypass, equalizing air pressure across the piston. Manual positioning of the controlled device is then possible.
3. The supply air filter will remove dispersed water or oil droplets from the supply air.
 4. The clevis and pin provide a connection from the actuator to linkage, transferring the output arm movement to the device being controlled.
 5. A dust and splash-proof NEMA Type 3 enclosure provides protection to the mechanics of the actuator and the DVC5000/6000 electronic unit.
 6. The optional heater/thermostat helps prevent the moisture in the actuator air lines from freezing. With the heater/thermostat installed, the actuator can effectively operate in temperatures down to -10°F (-23°C).
- c. **General Purpose.** The PowerVUE 8 x 14 actuator is used to accurately position the user's

final control element (flow control damper, fan inlet vanes, ball valve, etc.).

- d. **Actuator Operation (HART Versions using DVC6020).** Refer to the actuator operation diagram in Figure 1-2. In a typical control system operation, the user's process controller sends a 4-20 mA input signal directly to the DVC6000 electronic unit inside the actuator. The DVC6000 then positions the actuator according to the desired position indicated by the input signal by converting the input current signal to a pneumatic output pressure. The DVC6000 control sends the output air pressure to the top and bottom of the pneumatic cylinder locking the piston in place. As the actuator shaft rotates to its new position, a cam rotates against a feedback sensor on the DVC6000 electronic unit. The operating arm of the actuator is directly connected to the device control linkage through a clevis.
1. Characterizable Outputs. Customized user configurable response modes may be incorporated into the DVC6000 electronic unit. Refer to FIELDVUE® DVC6000 Series Digital Valve Controller Instruction Manual.
 2. Direction of Rotation. The user can configure for direct or inverse acting rotation by switching air tubing on the top and bottom of the pneumatic cylinder.
 3. Digital Communications. The DVC6000 valve controller uses 4-20 mA HART communication protocols. All information for setup and diagnostics is transmitted digitally via HART communications. A Rosemount 275 Handheld or similar communicator may be used or a laptop computer with ValveLink Software. Rosemount's Asset Management Solutions (AMS) offers the ValveLink software as an optional "snap-on" application. Instruments may be accessed individually or multiplexed through an "Interchange" unit, providing continuous access to any number of Rosemount instruments.
 4. The actuator's DVC5000 electronic unit, pneumatic, and mechanical drive devices are safely housed inside a NEMA Type 3 enclosure (dust cover).

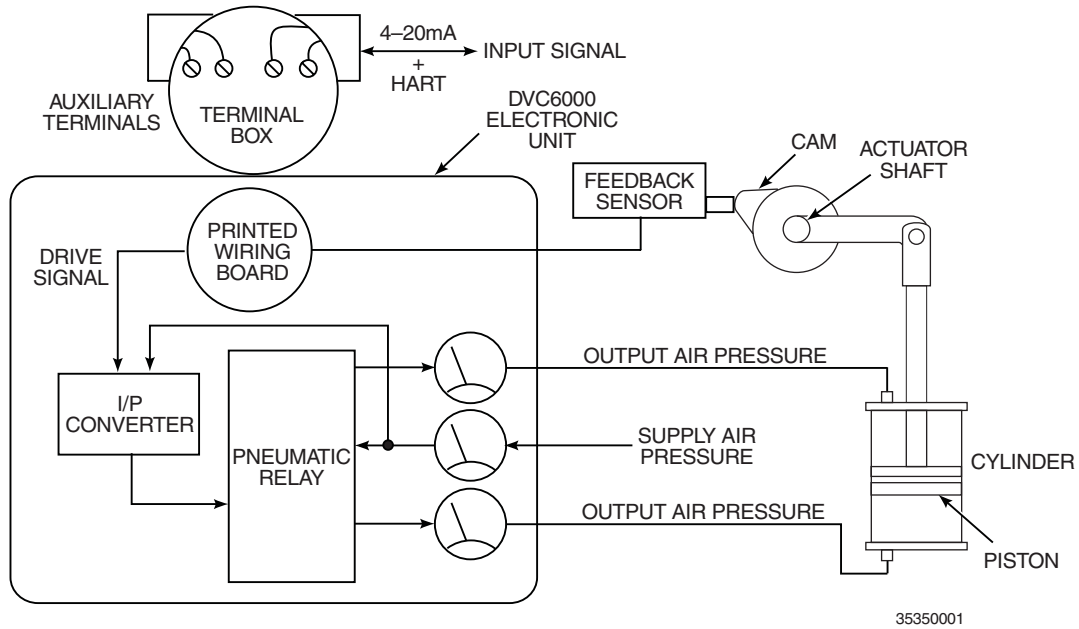

Figure 1-2. Actuator Operation Diagram - HART Versions using DVC6020

e. **Actuator Operation (FOUNDATION Fieldbus Versions using DVC5020f).** Refer to the actuator operation diagram in Figure 1-3. In a typical control system operation, the user's process controller sends a fieldbus input signal directly to the DVC5000 electronic unit inside the actuator. The DVC5000 then positions the actuator according to the desired position indicated by the input signal by converting the input current signal to a pneumatic output pressure. The DVC5000 control sends the output air pressure

to the top of the pneumatic cylinder and the Fairchild reverse relay. The reverse relay then sends the appropriate inverse air pressure to the bottom to the pneumatic cylinder locking the piston in place. As the actuator shaft rotates to its new position, a cam mounted on the actuator shaft rotates against a feedback sensor on the DVC5000 electronic unit. The actuator shaft is connected to the operating arm on the outside of the actuator, which is connected to device control linkage through a clevis.

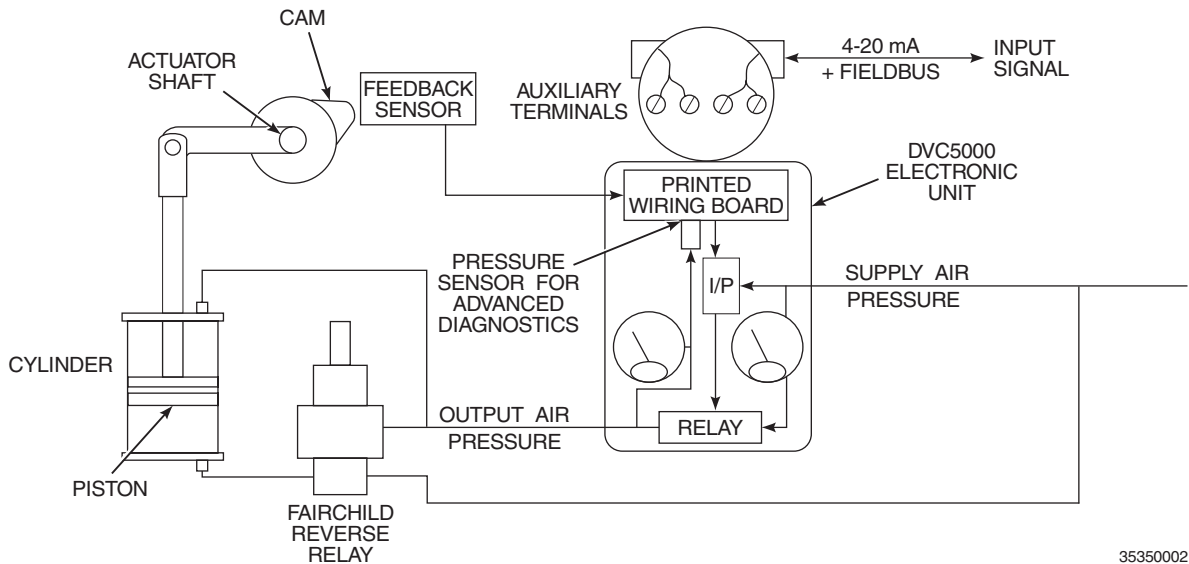

Figure 1-3. Actuator Operation Diagram - FOUNDATION Fieldbus Versions using DVC5020f

1. Characterizable Outputs. Customized user configurable response modes may be incorporated into the DVC5000 electronic unit. Refer to FIELDVUE® DVC5000 Series Digital Valve Controller Instruction Manual.
2. Direction of Rotation. The user can configure for direct or inverse acting rotation by switching air tubing on the top and bottom of the pneumatic cylinder.
3. Digital Communications. The DVC5000 controller uses FOUNDATION fieldbus communication protocols. All operator interface is via the host computer console. A handheld device will be available in the future.
4. The actuator's DVC5000 electronic unit, pneumatic, and mechanical drive devices are safely housed inside a NEMA Type 3 enclosure (dust cover).

- f. **System Considerations.** Prior to installation of the PowerVUE 8 x 14 actuator, check that you have all components necessary to install the system completely.

Once you have verified that you have all components, select the mounting location. A typical installation is illustrated in Figure 1-4. Determine where the actuator will be placed in terms of serviceability, ambient temperatures, environmental considerations, and convenience.

Actuator operating specifications are listed in Table 1-2. For DVC5000/6000 digital valve controller specifications refer to the applicable Digital Valve Controller Instruction Manual. Refer to Section II, Installation, before installing the digital valve controller.

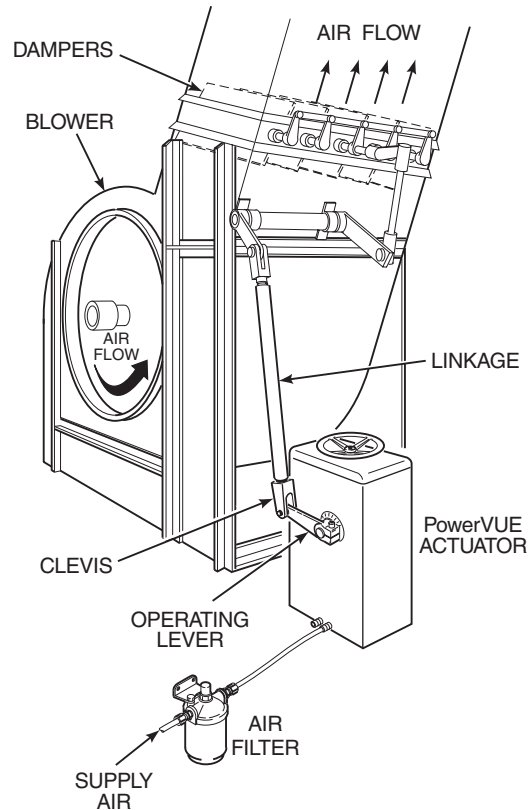

29330004

Figure 1-4. Typical Actuator Installation

- 1-4. **MODEL PVD 814 SPECIFICATIONS.** Table 1-2 contains information about the Model PVD 814 actuator operating characteristics. Use the table to make sure that available conditions are suitable for the actuator before choosing the mounting location.
- 1-5. **CONTROLLER SPECIFICATIONS.** Refer to the applicable DVC5000 or DVC6000 Series Digital Valve Controller Instruction Manual for controller specifications.

Table 1-2. Specifications for Model PVD 814 Actuator

Signal Requirements

Control Signal Inputs..... 4-20 mA signal with HART or fieldbus

Performance

Positioning Repeatability..... ±0.5% of full stroke or better
 Full Stroke Time (unloaded) 8 sec
 Stall Torque 4600 ft-lbs (6238 N·m)
 Maximum Friction Load..... 1100 ft-lbs (1492 N·m)
 Maximum Weight Load 1600 ft-lbs (2170 N·m)
 Maximum Load Capability of the Manual Operator 45 psi (310 kPa)
 Air Consumption 10 scfm steady rate
 8-in. Stroke 80° rotation

Environmental Requirements

Ambient Temperature Limits 0° to 120°F (-18° to 50°C)
 140°F (60°C) with increased maintenance

Electronics

See DVC5000/6000 specifications in applicable Digital Valve Controller Instruction Manual

Air Supply Requirements

Maximum 100 psig (689 kPa gage)
 Minimum 45 psig (310 kPa gage)
 Recommended 100 psig (690 kPa gage)



Fisher-Rosemount has satisfied all obligations coming from the European legislation to harmonize the product requirements in Europe. The PowerVUE actuator is a subcomponent of an actuating system, including user-provided items such as linkages, bearings, and dampers. The user must ensure that the entire actuating system is in conformity with the provisions of the European Machinery Directive EC Machinery Directive 89/392/EEC, as amended by Directive 91/368/EEC and Directive 93/44/EEC.

1-6. **STORAGE INSTRUCTIONS.** Use the following guidelines for actuator unit storage.

a. **Storage Environment.** Store the actuator in a warehouse environment that maintains the following conditions:

1. Ambient temperatures are above 45°F (7°C).
2. Relative humidity is below 80%.

b. **Preparation for Storage.**

WARNING

Keep Tectyl 506 away from heat, sparks, and open flames. Use with adequate ventilation to cure and to prevent an explosive atmosphere from forming.

CAUTION

Use only approved thinning methods when applying rust-preventive compounds. Do not apply heat to compound. Fire or explosion may result. Refer to manufacturer of rust-preventive compound for specific application, thinning, cleanup, and removal instructions.

Coat all non-painted surfaces and exposed metal with a rust-preventive compound (Tectyl 506 or a comparable substitute). If not using Tectyl 506, compare substitute with specifications for Tectyl 506 listed in Table 1-3.

c. **Storage Preventive Maintenance.** If storing the actuator unit for more than six months, use the following preventive maintenance guidelines.

1. Cycle the cylinder and piston, either manually or by air, every 6 months.
2. If there is high humidity, place a bag of desiccant into the DVC5000/6000 electronic unit.
3. After removing the actuator from storage, clean and lubricate the unit before installation as follows:
 - (a) Perform general cleaning and lubrication per paragraph 6-3.
 - (b) Clean and lubricate the cylinder and piston per paragraph 6-4 before installing the actuator.

Table 1-3. Specifications for Recommended Rust Preventive Compound

Approximate air dry time.....	1 hour
Low Temperature Flexibility (90° bend with no flaking or cracking).....	-10°F (-22.5°C)
Volatile Organic Content (V.O.C.).....	3.24 lbs/U.S. Gallon (400 grams/liter)
Accelerated Corrosion Tests: [(5% Salt Spray (Hours))	
ASTM (See Note 1)	
B-117 at 1.3 mils (2 x 4 x 1/8 in. polished steel panels).....	2000
DIN (See Note 2)	
50021 at 32.5 microns (125 x 200 mm DIN 1623 panels).....	168

NOTES: (1) ASTM (American Society for Testing and Materials)
 (2) DIN (Deutsche Industrie Normen)

SECTION II. INSTALLATION

2-1. **OVERVIEW.** The actuator is designed to be installed upright. The floor stand is bolted to a prepared horizontal foundation. A minimum of 45 psig (310 kPa gage) to a maximum of 100 psig (689 kPa gage) supply air pressure is needed at the mounting location.

2-2. SPECIAL INSTALLATION CONSIDERATIONS.

- a. **Foundation.** The actuator's torque is transmitted to the operating arm of the device being positioned. This torque is also transferred to the actuator's mass and foundation. To keep the actuator stationary, the foundation must be designed to handle the torque produced. Refer to paragraph 2-3 for detailed foundation requirements.
- b. **Supply Air.** A supply air pressure of 45 to 100 psig (310 to 689 kPa gage), minimum of 2 scfm (0.056 m³/min), is required. An air filter is provided to remove dispersed water or oil droplets from supply air.
- c. **Linkage Design.** Final control components play a large part in a control system. Special characteristics of the device being controlled affect system response and must be regarded in design and setup of an actuator system. In a normal installation, most users install the linkage with both the drive arm and damper driven arm positioned so that both arms establish an approximate right angle (90°) to the drive line at mid range of travel as illustrated in Figure 2-1. Refer to paragraph 2-5 for detailed information.

NOTE

The PowerVUE actuator may be set up to use only a portion of its total stroke. Refer to the FIELDVUE® DVC5000/6000 Series Digital Valve Controller Instruction Manual for customization information.

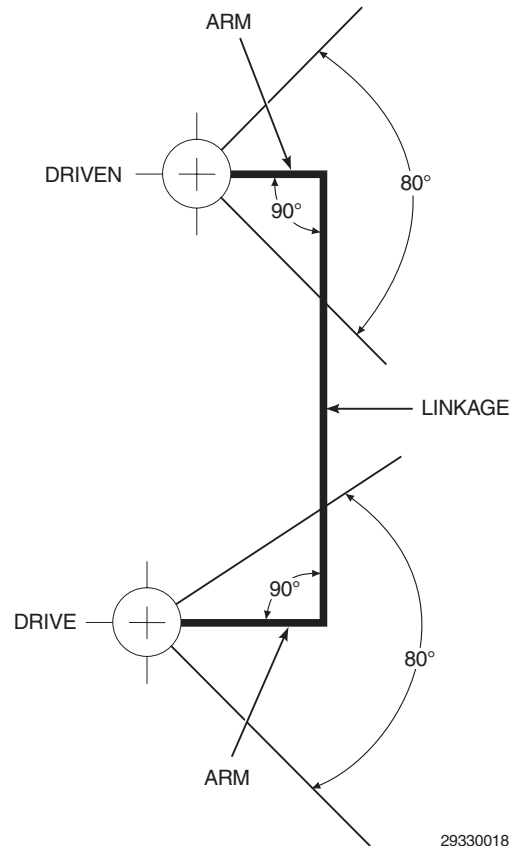

29330018

Figure 2-1. Angular Relationship of Drive and Driven Arms

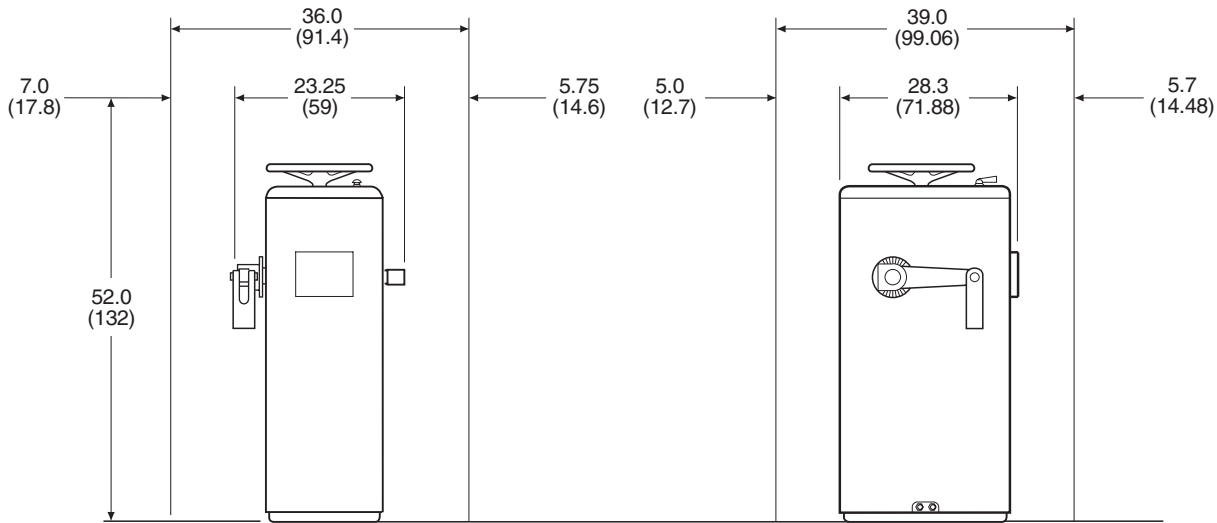

NOTES: 1. DIMENSIONS ARE IN INCHES WITH CENTIMETERS IN PARENTHESES.

2. SHOWN WITH OPTIONAL HANDWHEEL.

29330001

Figure 2-2. Clearance Requirements

2-3. ACTUATOR MOUNTING INSTRUCTIONS.

a. Working Clearance Requirements. Make sure area is clear of obstructions that will interfere with actuator operation and maintenance. For a standard unit, allow an open area of 52 in. (132 cm) vertically from the foundation, 39 in. (99.06 cm) side to side, and 36 in. (91.4 cm) front to back (Figure 2-2). This will allow for handwheel operation, removal of the dust cover, and unit maintenance.

b. Location Selection.

1. Select the location for the actuator as near to the device being controlled as possible. Ensure the necessary clearance for operation and maintenance, as specified in paragraph 2-3.a, is available.
2. Refer to Table 1-2 to ensure conditions are suitable for the actuator. Refer to the valve controller manual for environmental conditions required for the electronic unit.

c. Mounting Procedure.

1. Design and Manufacture of Foundation.
 - (a) Foundation must be able to withstand at least 5500 ft-lbs (7458 N·m) torque plus 950 lbs (431.3 kg) actuator weight. Refer to Figure 2-3 for footprint dimensions of actuator. Use this footprint as a guide to design the foundation to match the base of the actuator.

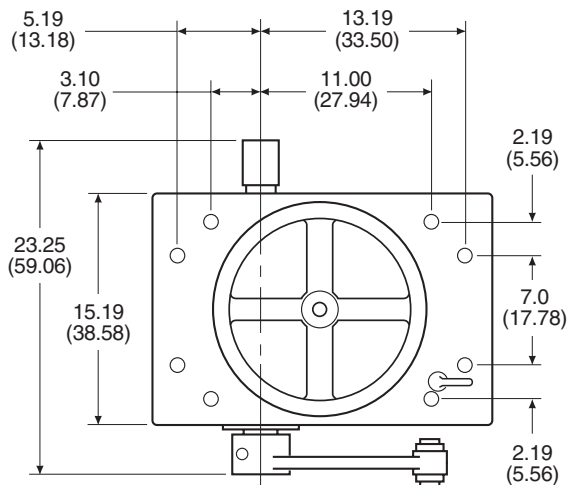

NOTE: DIMENSIONS ARE IN INCHES WITH CENTIMETERS IN PARENTHESES.

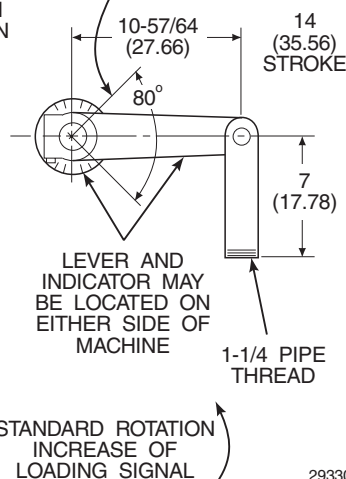

29330002

Figure 2-3. Actuator Unit Mounting and Installation (Footprint) Drawing

- (b) Mounting holes in the base are drilled for 3/4 in. foundation bolts. Decide which foundation material is best suited for your application, steel or concrete, then design and manufacture required foundation.

2. Installation.

- (a) Install actuator on foundation with 3/4 in. bolts and standard flat washers.
- (b) Make sure actuator is level. Check by measuring side to side and front to back with a level.
- (c) If actuator is not level, remove 3/4 in. mounting bolts and install shims between the actuator and foundation. Continue this process until the actuator is level when 3/4 in. mounting bolts are tightened. This will prevent distortion of the actuator stand.
- (d) If installed on a concrete foundation, grout foundation with additional concrete to prevent distortion of the actuator stand.

2-4. **AIR SUPPLY INSTALLATION.** Refer to Figure 2-4 and match the torque load required to position your device to the “maximum torque required” axis along the bottom of the graph. From this point, move vertically up to the control torque curve. From the point that intersects the control torque curve, move horizontally to the left scale labeled “supply air pressure”. This is the minimum supply air required to develop the required control torque. The stall torque curve represents the maximum amount of torque the actuator will produce for a given supply air pressure before stalling out.

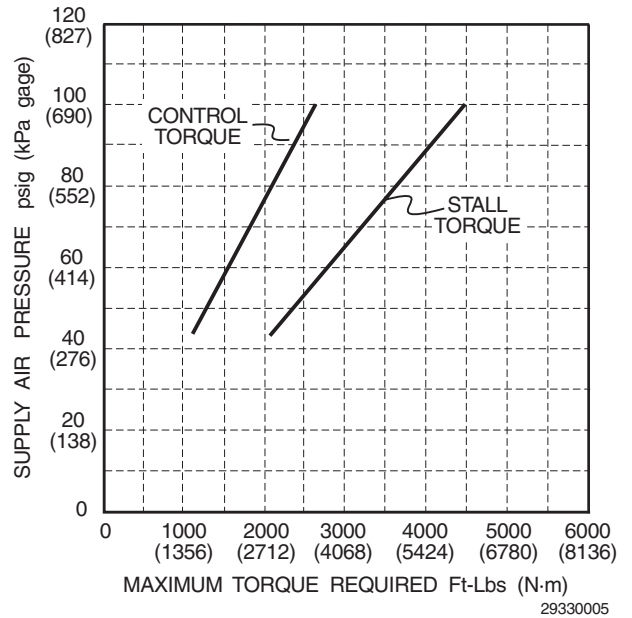

Figure 2-4. 8 x 14 Actuator Torque Chart

- a. **Supply Air Requirements.** Operating supply air pressure range for the PowerVUE actuator is 45 to 100 psig (310 to 689 kPa gage).
- b. **Supply Air Connection.** Basic schematic is shown in Figure 2-5.
 - 1. Mount bracket for air filter directly on the back of the stand assembly. If this position is unsuitable, mount air filter within 15 ft. (4.6 m) of the actuator.

NOTE

Prior to connecting the supply air line, purge air system until all moisture and debris are blown out.

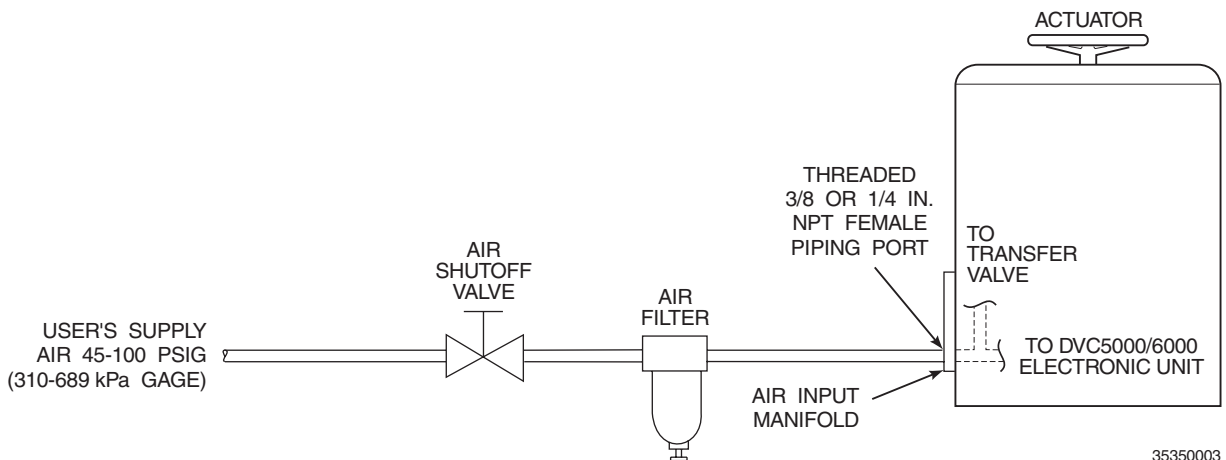
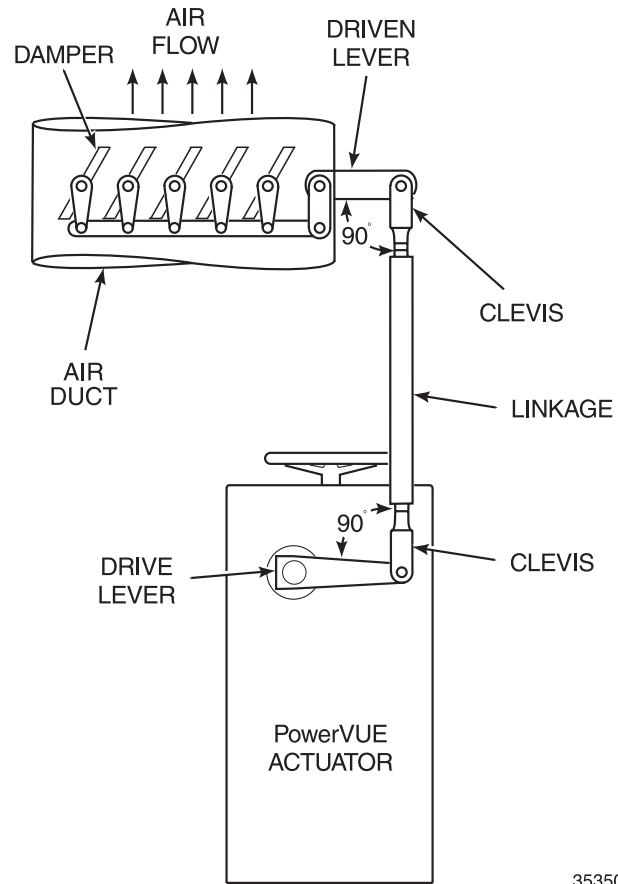

Figure 2-5. Air Piping Schematic

2. Purge air supply system and connect air supply line to the air filter inlet. Run a second line from the air filter outlet to the actuator air input manifold. Fittings may be 3/8 in. or 1/4 in. NPT.

2-5. LINKAGE INSTALLATION. In a normal installation (paragraph 2-2), both the drive and driven arms establish an approximate right angle (90°) to the drive line when at mid-range of travel (Figure 2-1). Because of this, the “ruler/protractor method” for installing linkage is recommended. The linkage described is 1.5 in. (38.1 mm) in diameter. The installation method is as follows. Refer to Figure 2-6.

- a. Position both the drive and driven arms in the mid-range position. The arms should be parallel to one another.
- b. Connect the drive arm to the driven arm with clevis, clevis pins, and an appropriate length of pipe.
- c. Manually adjust the actuator to verify proper operation of the device being controlled.
- d. If it is necessary to make a minor length adjustment to the linkage, turn the link pipe in or out at the clevis as required.



35350004

Figure 2-6. Linkage Installation

SECTION III. DVC5000/6000 ELECTRONICS SETUP

3-1. INTRODUCTION. The DVC5000/6000 electronic unit has been installed, set up, and calibrated at Rosemount. Additional tuning of the DVC5000/6000 may be required to fit particular applications.

A FIELDVUE DVC5000/6000 Series Digital Valve Controller Instruction Manual has been provided for additional information on the DVC5000/6000 electronic unit. Refer to the following sections in the valve controller instruction manual for specific information.

- a. Electrical installation information is contained in Section 2, Installation.
- b. Initial Setup and Calibration, Section 4.
- c. Detailed Setup, Section 5.
- d. Calibration, Section 6.
- e. Maintenance, Section 9.
- f. Parts, Section 10.

SECTION IV. STARTUP CALIBRATION

4-1. **REVERSE RELAY CALIBRATION (DVC5000 only).** The PowerVUE actuator uses a Fairchild Model 25463 reverse relay. The reverse relay provides an output pressure which follows the equation $P_O = K - P_S$. Where P_O is the output pressure, K is the spring bias, and P_S is the input pressure from the DVC5000 electronic unit. Perform the following procedure to adjust the spring bias during calibration.

- a. Manually position the actuator cylinder off its end stops.
- b. Adjust the supply air to the desired operating air pressure. It is recommended that the air supply be adjusted to the level likely to be experienced during normal operation.
- c. Remove the cap nut from the top of the reverse relay, Figure 4-1.
- d. Loosen the lock nut on the range screw.
- e. Turn the range screw until the output gauge on the DVC5000 reads 50% of the desired operating air pressure.

4-2. **DVC5000/6000 CALIBRATION.** Refer to the FIELDVUE DVC5000 or DVC6000 Series Digital Valve Controller Instruction Manual for information on calibrating the DVC5000 or DVC6000 valve controller. Calibration information is contained in Section 6.

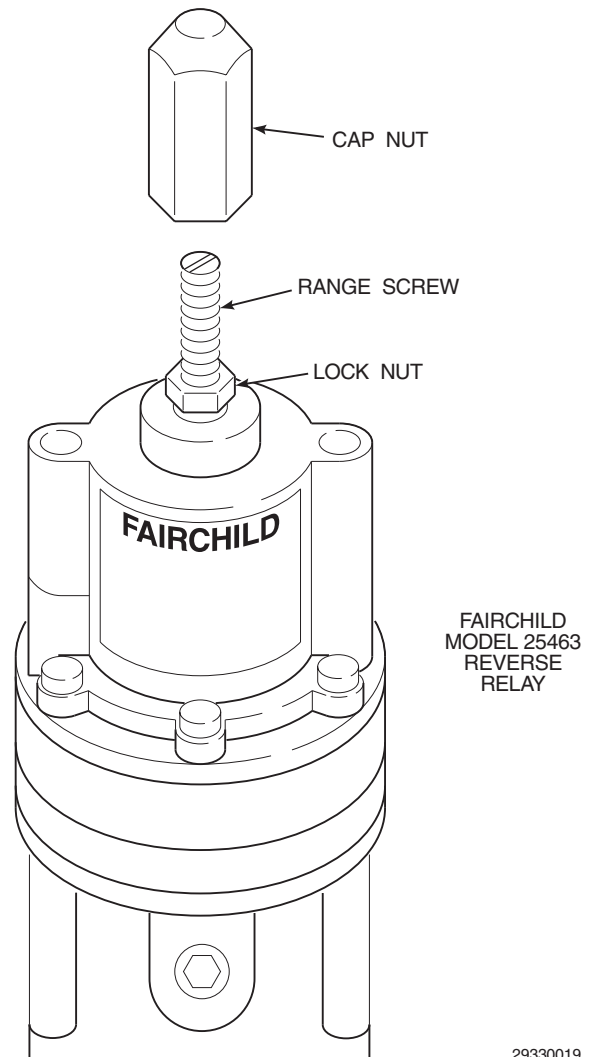
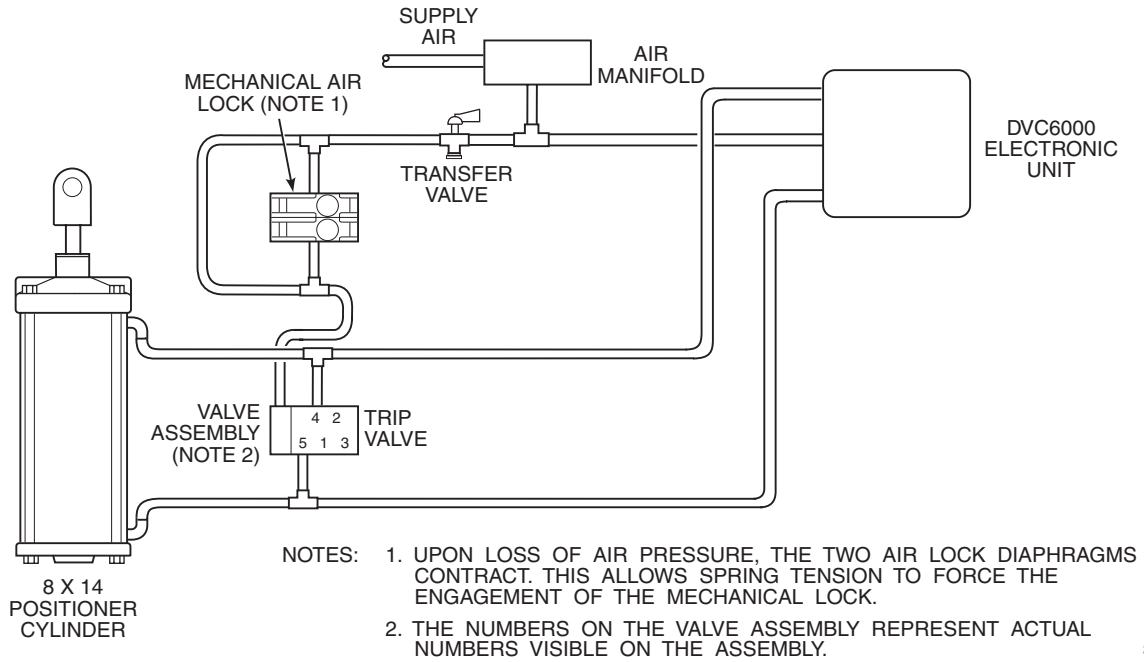

Figure 4-1. Reverse Relay Calibration

SECTION V. TROUBLESHOOTING

5-1. **OVERVIEW.** Refer to the applicable FIELDVUE DVC5000 or DVC6000 Series Digital Valve Controller Instruction Manual for troubleshooting the actuator electronics. Figure 5-1 shows an air piping diagram for actuators controlled with the DVC6000

series valve controller. Figure 5-2 is the air piping diagram for actuators controlled with a DVC5000 series controller. Refer to the applicable diagram as an aid in troubleshooting pneumatic problems.



35350005

Figure 5-1. Actuator Air Piping Diagram – HART Versions using DVC6020

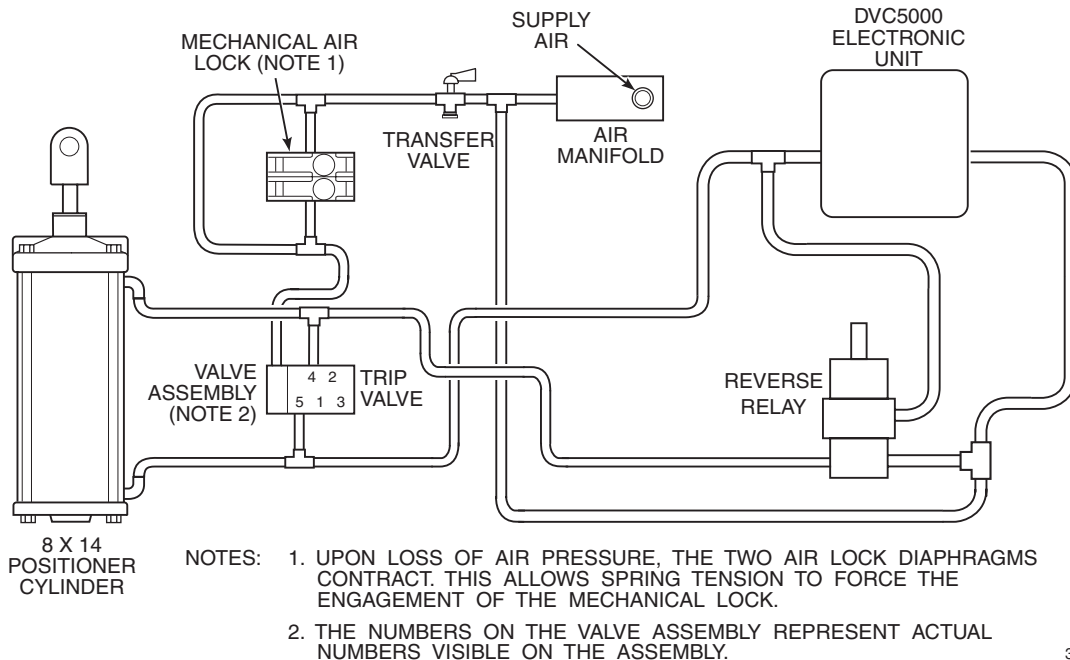

35350006

Figure 5-2. Actuator Air Piping Diagram – FOUNDATION Fieldbus Versions using DVC5020f

LUBRICATION CHART

NOTE 1: USING A GREASE GUN, LUBRICATE ZERK FITTINGS AT PISTON ROD CLEVIS, SHAFT ASSEMBLY, BUSHING BLOCKS, HANDWHEEL, SHAFT BLOCK, WORM SHAFT BLOCK, AND BEARING BLOCKS.

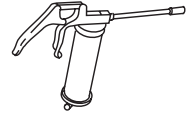

NOTE 2: WIPE PISTON ROD WITH A CLEAN SHOP TOWEL. APPLY A LIGHT COATING OF McLUBE MoS -793. WIPE EXCESS GREASE OFF WITH CLEAN SHOP TOWEL.



NOTE 3: DVC5000/6000 ELECTRONIC UNIT, REVERSE RELAY, AND MOUNTING BRACKET NOT SHOWN.

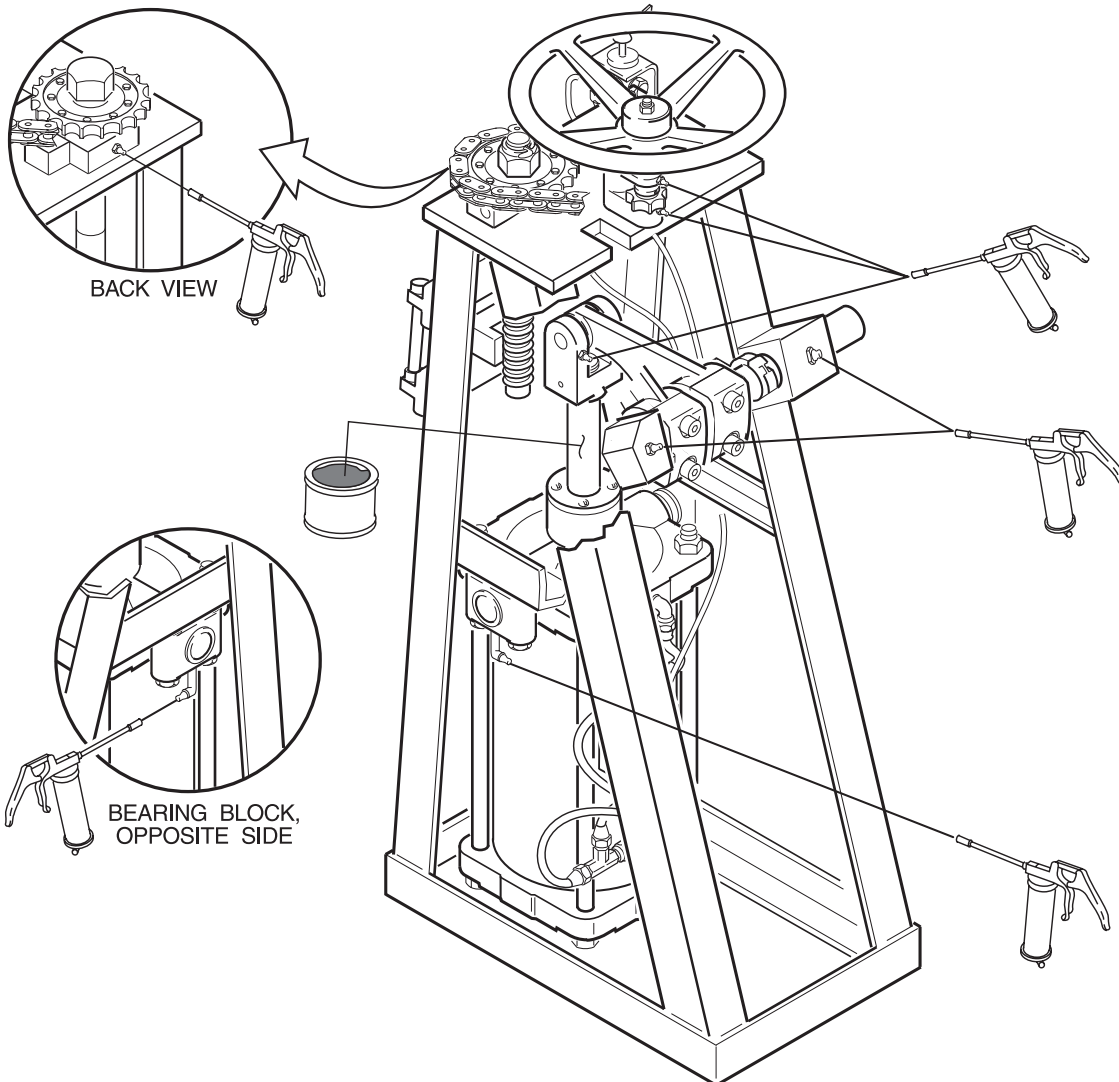

35350012

Figure 6-1. Lubrication Chart

SECTION VI. PERIODIC MAINTENANCE

6-1. OVERVIEW. This section describes preventive maintenance for the PowerVUE Model PVD 814 Fan/Damper Actuator and common options. Preventive maintenance is necessary at specific intervals to reduce wear and tear on the actuator.

WARNING

Before performing any maintenance or repair action on actuator, shut off supply air and any electronic signals to actuator. Isolate actuator from all systems connected to the actuator. Severe injury or death may result from large torque produced by actuator.

WARNING

Clean actuator in a well ventilated area. Avoid inhalation of solvent fumes and prolonged exposure of skin to cleaning solvent. Follow all instructions on the Material Safety Data Sheet (MSDS) of the solvent being used. Severe injury or death may result from improper use.

6-2. MAINTENANCE SCHEDULE. Use Table 6-1 as a guideline for preventive maintenance. The frequency of maintenance varies directly with plant conditions and operational load. Extremely dusty conditions or high temperatures will require more frequent maintenance to the actuator.

6-3. GENERAL CLEANING AND LUBRICATION. Clean actuator's exterior of all grease buildup with commercial dry cleaning solvent. To lubricate actuator, use McLube MoS₂-793 or equivalent and refer to Figure 6-1.

McLube MoS₂-793 can be purchased from Rosemount Analytical Inc. (P/N 183512) or directly from the manufacturer:

McGee Industries, Inc.
9 Crozerville Rd.
Aston, PA 19014

Table 6-1. Maintenance Schedule

TIME INTERVAL (Approximate)	MAINTENANCE ACTION
6 months	Perform general cleaning and lubrication. Refer to paragraph 6-3.
2 years	Clean, inspect, and lubricate cylinder and piston assembly. Refer to paragraph 6-4.
2 years	Clean, inspect, and adjust mechanical air lock option. Refer to paragraph 6-5.

- 6-4. **CYLINDER AND PISTON CLEANING AND LUBRICATION.** Disassemble, clean, and lubricate piston and cylinder assembly approximately every two years. Refer to Figure 6-2 and use the following procedure.

WARNING

Before performing any maintenance or repair action on actuator, shut off supply air and any electronic signals to actuator. Isolate actuator from all systems connected to the actuator. Severe injury or death may result from large torque produced by actuator.

- a. Remove actuator from service; shut off or disconnect air supply as applicable to system.
- b. Position transfer valve to MANUAL position.

WARNING

Residual air must be bled off of cylinder before removal of cylinder head. If air is not bled off, eye injury may result.

- c. Loosen upper and lower air hoses (9 and 15). Allow residual air to bleed through loose connections.
- d. Label hoses (9 and 15) "upper and "lower", respectively. Disconnect hoses from 90° elbows (8 and 16).
- e. Remove cylinder/piston assembly as follows:
 1. Loosen set screw (1) and remove clevis pin (3). Disconnect cylinder lever (2) from clevis (25).
 2. Support cylinder assembly with 2 x 4 in. boards prior to removing nuts (4).

WARNING

Failure to support the cylinder assembly could result in the assembly falling over, causing severe personal injury. Ensure the cylinder is adequately supported prior to removing nuts.

3. Remove nuts (4), lockwashers (5), and screws (7).

CAUTION

Do not scratch piston rod. Use caution when removing and handling upper cylinder head, piston, and piston rod. If piston rod is scratched, actuator will produce lower torque and cause decreased packing life.

4. Carefully remove cylinder/piston assembly from frame.
- f. Remove bearing blocks (6) from upper cylinder head (20).

CAUTION

Do not pull piston and shaft assembly out of cylinder head. Damage to gland bushings and packing may occur.

- g. Remove, clean, inspect, and lubricate piston assembly as follows:
 1. Remove nuts (22). Pull piston assembly and upper cylinder head free of the cylinder. Remove and discard gasket (10).
 2. Remove lower cylinder head (14). Remove and discard gasket (13).
 3. Remove old grease from piston assembly and piston rod. Clean piston and rod with commercial grade dry cleaning solvent.
 4. Inspect piston rod. Pay special attention to the section of rod which passes through rod packing (21). Replace rod if worn, damaged or pitted. Refer to Section VII, Corrective Maintenance, for replacement procedures.
 5. Remove screws (24) and gland cap (23).
 6. Carefully wipe old grease from rod packing (21). Remove and replace rod packing if torn or leaking air. Refer to Section VII, Corrective Maintenance, for replacement procedures.
 7. Pack area around rod packing with McLube MoS₂-793 or an equivalent grease.
 8. Reinstall gland cap (23) and secure with screws.

1. Set Screw
2. Cylinder Lever
3. Clevis Pin
4. Nut
5. Lockwasher
6. Bearing Block
7. Screw
8. 90° Elbow
9. Upper Air Hose
10. Gasket
11. Piston
12. Cylinder
13. Gasket
14. Lower Cylinder Head
15. Lower Air Hose
16. 90° Elbow
17. Nut
18. Cylinder Stud
19. Piston Rod
20. Upper Cylinder Head
21. Rod Packing
22. Nut
23. Gland Cap
24. Screw
25. Clevis

NOTE: NOT ALL ITEMS IDENTIFIED ARE AVAILABLE FOR INDIVIDUAL SALE. SEE SECTION IX, RECOMMENDED SPARE PARTS, FOR A LIST OF AVAILABLE PARTS.

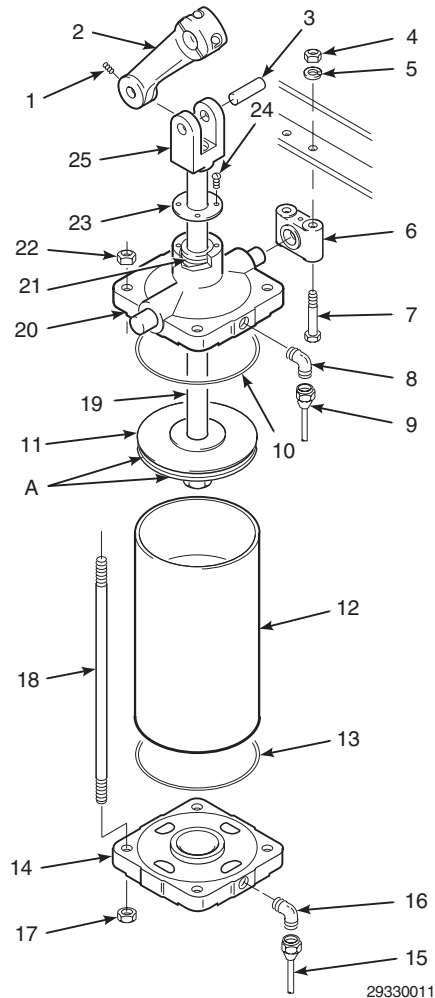

Figure 6-2. Cylinder Exploded View

9. Wipe piston rod (19) with a clean cloth. Apply a light coating of McLube MoS₂-793 or equivalent grease.
10. Pack piston concave (area A) with McLube MoS₂-793 or equivalent grease.
- h. Wipe interior of cylinder (12) with a clean cloth and commercial grade dry cleaning solvent. Inspect cylinder for cracks and scoring and replace cylinder if damaged. Refer to Section VII, Corrective Maintenance, for replacement procedures. Allow cylinder to air dry before reassembly.
- i. Reassemble cylinder and piston assembly as follows:
 1. Lightly lubricate and install new gasket (10) into seal groove on upper cylinder head (20).
 2. Lightly lubricate and install new gasket (13) into seal groove on lower cylinder head (14).
 3. Position cylinder onto lower cylinder head (14).
 4. Install upper cylinder head with piston assembly into cylinder. Ensure elbows (8 and 16) are on the same side of cylinder.
 5. Secure upper head to lower head with cylinder studs (18) and nuts (17 and 22).
 6. Install bearing blocks (6) onto upper cylinder head.
 7. Place cylinder/piston assembly within frame and onto 2 x 4 inch boards for support.

8. Secure bearing blocks (6) to frame with screws (7), lockwashers (5) and nuts (4). Remove the 2 x 4 inch board supports.
 9. Secure cylinder lever (2) to clevis (25) with clevis pin (3). Secure clevis pin with set screw (1).
 10. Install upper air hose to 90° elbow (8).
 11. Install lower air hose to 90° elbow (16).
- j. Resupply air to cylinder and check for air leaks using a “snoop” type leak detector.
 - k. Lubricate clevis and bearing blocks using a grease gun filled with McLube MoS₂-793 or equivalent.
 - l. Refer to the FIELDVUE DVC5000 or DVC6000 Series Digital Valve Controller Instruction Manual and calibrate the DVC5000/6000 electronic unit. Return actuator to service.

6-5. AIR LOCK ADJUSTMENT. To adjust air lock, refer to Figure 6-3 and use the following procedure.

WARNING

Before performing any maintenance or repair action on actuator, shut off supply air and any electronic signals to actuator. Isolate actuator from all systems connected to the actuator. Severe injury or death may result from large torque produced by actuator.

- a. Remove actuator from service and shut off or disconnect air supply as applicable to system.
- b. Position transfer valve to automatic position. Manually pull clapper lever (6) open. Prop clapper lever to keep open.
- c. Measure clearance between worm shaft (2) and worm gear sector (1). Proper clearance is between 1/8 and 3/16 in. (3.18 to 4.76 mm).
- d. If clearance is not in correct range, loosen lock nut (5) and adjust stop bolt (3) until clearance between worm shaft and gear sector is in range.
- e. Tighten lock nut (5).
- f. Remove prop from clapper lever (6).

CLEARANCE BETWEEN ITEMS 1 AND 2 IS BETWEEN 1/8 AND 3/16 IN. (3.18 TO 4.76 MM)

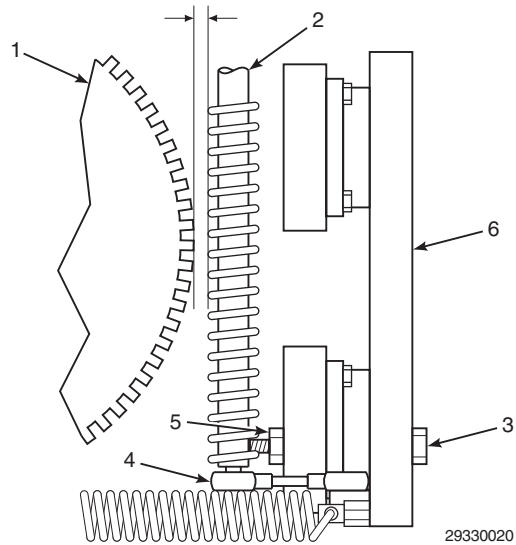

NOTE: NOT ALL ITEMS IDENTIFIED ARE AVAILABLE FOR INDIVIDUAL SALE. SEE SECTION IX, RECOMMENDED SPARE PARTS FOR A LIST OF AVAILABLE PARTS.

- | | |
|---------------------|------------------|
| 1. Worm Gear Sector | 4. Shaft Bearing |
| 2. Worm Shaft | 5. Lock Nut |
| 3. Stop Bolt | 6. Clapper Lever |

Figure 6-3. Air Lock Diaphragm

- g. Place transfer valve in MANUAL position and ensure worm shaft engages with gear sector. If engagement fails to occur, readjust air lock.
- h. Return actuator to service.

6-6. MECHANICAL LINKAGE CLEANING AND LUBRICATION. Clean actuator’s mechanical linkage of all grease buildup and inspect for damage and wear every 2 years. Refer to Figure 6-4 and use the following procedure.

- a. Remove actuator from service and shut off or disconnect air supply as applicable.
- b. Remove grease from handwheel sprocket (11) and worm sprocket (2). Inspect sprockets for damage and wear. Replace if required.
- c. Remove grease from chain (8). Inspect chain for damage. Replace if required.
- d. Ensure handwheel shaft block (14) is securely mounted. Tighten if required.

- e. Ensure pin blocks (3) are secure. Tighten if required.
- f. Turn handwheel (7) to rotate worm shaft (17).
Inspect worm shaft for damage.

- g. Lubricate worm shaft block (5) and handwheel shaft block (14) using a grease gun filled with MoS₂-793 grease or equivalent.
- h. Lubricate chain (8) with a light coating of MoS₂-793 grease or equivalent.

1. Nut
2. Worm Sprocket
3. Pin Block
4. Pin
5. Worm Shaft Block
6. Nut
7. Handwheel
8. Chain
9. Handwheel/Sprocket Shaft
10. Key
11. Handwheel Sprocket
12. Cotter Pin
13. Grease Fitting
14. Handwheel Shaft Block
15. Screw
16. Screw
17. Worm Shaft
18. Key Bar
19. Cotter Pin
20. Set Screw
21. Collar
22. Thrust Washer
23. Grease Fitting

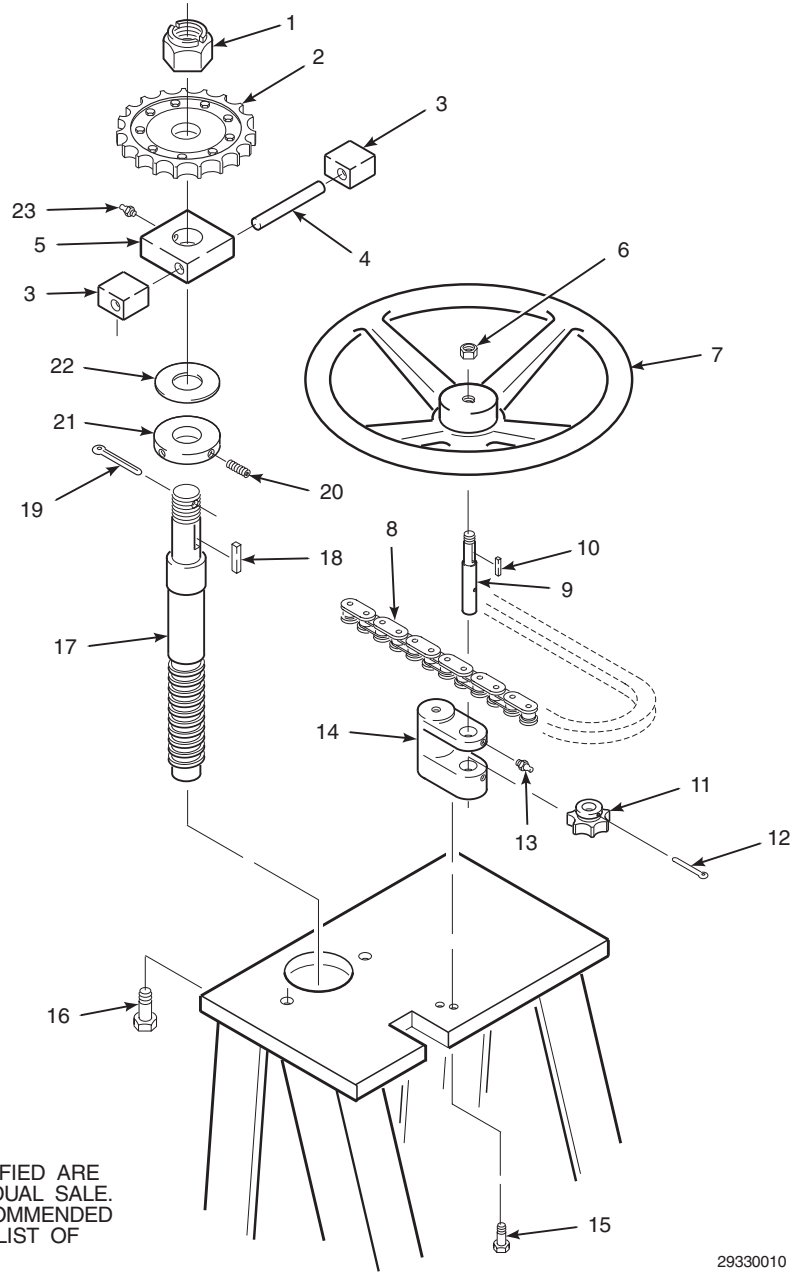

29330010

Figure 6-4. Mechanical Linkage

SECTION VII. CORRECTIVE MAINTENANCE

- 7-1. **OVERVIEW.** This section describes corrective maintenance for the PowerVUE Model PVD 814 fan/damper actuator. If the specific cause of a problem is not known, refer to Section V, Troubleshooting. Spare parts referred to are available from Rosemount. Refer to Section IX of this manual for part numbers and ordering information.

WARNING

Before performing any maintenance or repair action on actuator, shut off supply air and any electronic signals to actuator. Isolate actuator from all systems connected to the actuator. Severe injury or death may result from large torque produced by actuator.

- 7-2. **CYLINDER HEAD GASKETS, PISTON, AND ROD PACKING.** Use the following procedure to replace the upper and lower cylinder head gaskets, cylinder piston cup, and rod packing.

- a. Remove cylinder and piston assembly as follows:
1. Remove actuator from service. Shut off or disconnect supply air as applicable to the system.
 2. Move transfer valve to MANUAL position.

WARNING

Residual air must be bled off of cylinder before removal of cylinder head. If air is not bled off, eye injury may result.

3. Loosen upper and lower air hoses (21 and 31, Figure 7-1) and allow residual air to bleed through loose connections.
4. Tag hoses (21 and 31) "upper" and "lower", respectively. Disconnect hoses from 90° elbows (20 and 30).
5. Loosen set screw (1) and remove clevis pin (3). Disconnect cylinder lever (2) from clevis (5).

WARNING

A loose cylinder may fall over and cause severe personal injury. Before removing bearing block nuts (9), ensure cylinder's entire weight is firmly supported by 2 x 4 in. boards.

6. Support cylinder assembly with 2 x 4 inch boards prior to removing nuts (9).
7. Remove nuts (9), lockwashers (10), and screws (12).

CAUTION

Do not scratch piston rod. Use caution when removing and handling upper cylinder head, piston, and piston rod. If piston rod is scratched, actuator will produce lower torque and decreased packing life will result.

8. Carefully remove cylinder/piston assembly from frame.

1. Set Screw
2. Cylinder Lever
3. Clevis Pin
4. Grease Fitting
5. Clevis
6. Set Screw
7. Gland Cap Screw
8. Gland Cap
9. Nut
10. Lockwasher
11. Bearing Block
12. Screw
13. Rod Packing (Female Adaptor)
14. V-Ring Packing
15. Rod Packing (Male Adaptor)
16. Nut
17. Upper Cylinder Head
18. Gasket
19. Piston Rod
20. 90° Elbow
21. Upper Air Hose
22. Upper Piston O-Ring
23. Piston Follower
24. Lower Piston O-Ring
25. Piston
26. Stop Nut
27. Cylinder
28. Gasket
29. Lower Cylinder Head
30. 90° Elbow
31. Lower Air Hose
32. Nut
33. Cylinder Stud

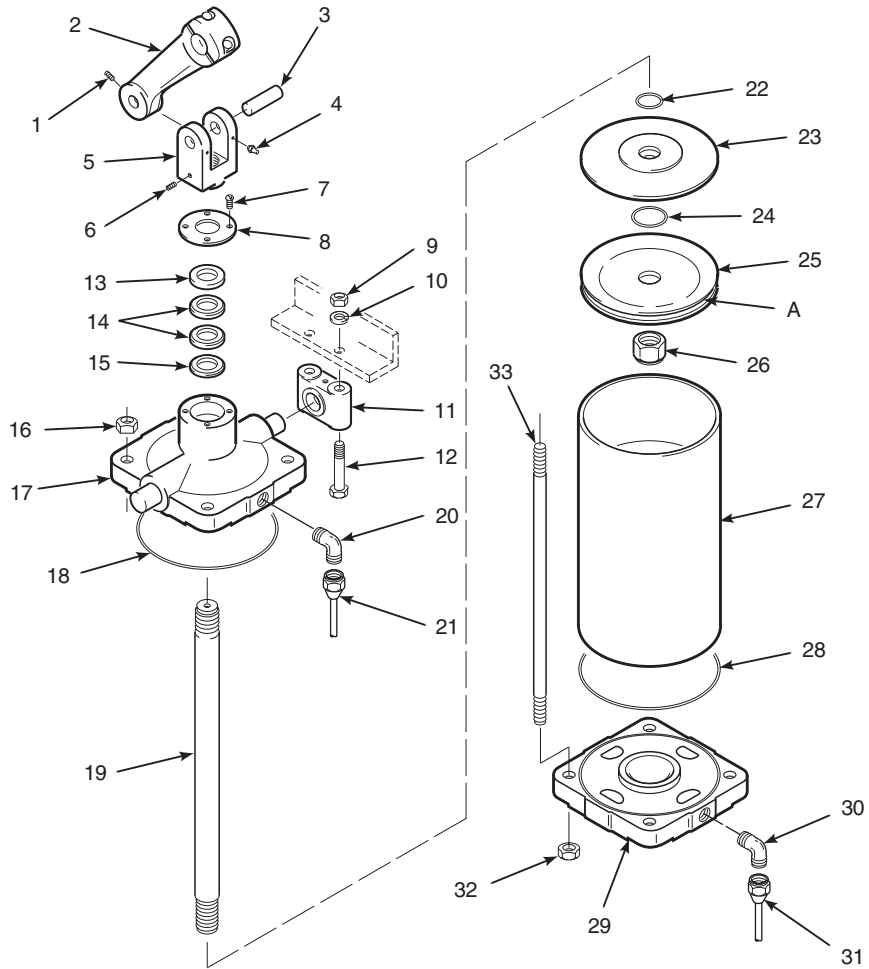

NOTE: NOT ALL ITEMS IDENTIFIED ARE AVAILABLE FOR INDIVIDUAL SALE. SEE SECTION IX, RECOMMENDED SPARE PARTS FOR A LIST OF AVAILABLE PARTS.

29330012

Figure 7-1. Cylinder Exploded View

b. Disassemble cylinder and piston assembly as follows:

1. Remove bearing blocks (11) from upper cylinder head (17).

CAUTION

Do not pull piston and shaft assembly out of cylinder head. Damage to gland bushings and packing may occur.

2. Remove piston assembly and packing.
3. Remove nuts (16). Pull piston assembly and upper cylinder head (17) free of the cylinder. Remove and discard gasket (18).

4. Remove lower cylinder head (29). Remove and discard gasket (28).
5. Remove gland cap screws (7).
6. Move gland cap (8) to access packing.
7. Remove packings (13, 14, and 15).
8. Remove stop nut (26). Remove piston assembly (22 through 25) from piston rod (19).

c. Clean, reassemble, and lubricate the piston and cylinder assembly as follows:

1. Clean piston rod and inner cylinder with a clean cloth.

2. Spray piston rod and inner cylinder with a light coating of dry film lubricant (molybdenum disulfide).

CAUTION

Piston rod threads can damage rod packing, causing leakage. Exercise care when installing packing.

3. Pack new rod packings (13, 14, and 15) with MoS₂-793. Carefully place over piston rod as illustrated in Figure 7-1.
 4. Insert lower end of rod (19) through top of upper cylinder head (17).
 5. Carefully press packings (13, 14, and 15) into place.
 6. Secure gland cap (8) to cylinder head with screws (7).
 7. Replace o-rings (22 and 24) with new lightly lubricated o-rings.
 8. Screw piston follower (23) onto piston rod.
 9. Place new piston (25) onto piston rod with machined side of piston facing follower (23).
 10. Secure piston assembly to piston rod with stop nut (26).
 11. Pack concave area (A) of piston with McLube MoS₂-793.
 12. Clean gasket sealing surfaces on cylinder (27) and cylinder heads (17 and 29).
 13. Lightly lubricate and install new gasket (18) onto upper cylinder head (17).
 14. Lightly lubricate and install new gasket (28) onto lower cylinder head (29).
 15. Install upper cylinder head (17) and piston assembly onto cylinder (27).
 16. Install lower cylinder head (29) onto cylinder. Ensure elbows (20 and 30) are on same side of cylinder.
 17. Secure upper cylinder head to lower cylinder head with cylinder studs (33) and nuts (16 and 32).
- d.** Install cylinder/piston assembly as follows:
1. Install bearing blocks (11) onto upper cylinder head.
 2. Place cylinder/piston assembly within actuator frame and onto 2 x 4 inch boards for support.
 3. Secure bearing blocks (11) to frame with screws (12), lockwashers (10), and nuts (9). Remove the 2 x 4 inch board supports.
 4. Secure cylinder lever (2) to clevis (5) with clevis pin (3). Secure clevis pin with set screw (1).
 5. Install upper air hose to 90° elbow (20).
 6. Install lower air supply hose to 90° elbow (30).
- e.** Resupply air to cylinder and check for leaks using a “snoop” type detector. Repair any leaks.
- f.** Lubricate clevis and bearing blocks using a grease gun filled with McLube MoS₂-793 or equivalent.
- g.** Refer to the FIELDVUE DVC5000 or DVC6000 Series Digital Valve Controller Instruction Manual and calibrate the DVC5000/6000 electronic unit. Return the actuator to service.

7-3. CYLINDER REPLACEMENT. To replace an assembled cylinder, follow the procedures outlined in paragraph 7-2. Step 7-2.a covers cylinder removal, and steps d through g cover installation.

7-4. AIR LOCK DIAPHRAGM. Refer to Figure 7-2, and the following procedure to replace the air lock diaphragm.

a. Remove actuator from service. Disassemble air lock and remove old diaphragm as follows:

1. Disconnect air line (20) from T-fitting (21).
2. Loosen nut (4) and remove screw (1) and washer (2) from spring nut (5).
3. Remove air lock stop bolt (47), washer (46), and nut (29).
4. Remove screws (26) from shaft bearing (25) at bottom of worm shaft (51).
5. Remove screws (45) from couplings (37).
6. Swing clapper lever (42) out of the way.
7. Remove screws (39) and remove diaphragm plate (38).
8. Pull on coupling (37) from diaphragm stud (34). Separate diaphragm stud, diaphragm (35), and shield (36).

b. Reassemble and adjust air lock as follows:

1. Assemble new diaphragm (35) with stud (34) and shield (36). Secure together with coupling (37).
2. Place diaphragm assembly in diaphragm chamber (24) and install diaphragm plate (38).
3. Swing clapper lever (42) over diaphragm and install screws (45) into couplings (37).
4. Attach shaft bearings (25) to worm shaft (51) with screw (26).
5. Install air lock stop bolt (47), washer (46), and nut (29).
6. Connect air lock spring nut (4) with screw (1) and washer (2). Tighten nut (4) against spring nut.
7. Connect air line (20) to T-fitting (21).
8. Adjust air lock spring tension.

- (a) Apply air supply pressure of 30 psi (207 kPa) to actuator.
- (b) Move transfer valve to MANUAL position.
- (c) Loosen nut (4) and tighten screw (1) until clapper lever is held closed by spring (50). Tighten nut (4).
- (d) Move transfer valve to automatic position. If clapper lever does not open, loosen nut (4) and decrease spring tension with screw (1) until clapper lever is fully open. Tighten nut (4) against spring nut (5).

c. Return the actuator to service.

7-5. TRANSFER VALVE. Refer to Figure 7-2 and the following procedure to replace the transfer valve.

a. Remove actuator from service.

b. Remove transfer valve knob (8) from transfer valve.

c. Remove screws (10) and dust cover.

d. Disconnect supply air line (18) from elbow (17). Remove elbow from transfer valve.

e. Disconnect air line (20) from adaptor (19). Remove adaptor from transfer valve.

f. Remove screws (11) from valve bracket (12) and remove valve.

g. Install adaptor (19) and elbow (17) on new transfer valve. Install new valve on valve bracket with screws (11).

h. Connect air supply line to (18) to elbow (17). Connect air line (20) to adaptor (19).

i. Resupply air to actuator and test for leakage around transfer valve using a “snoop” type leak detector.

j. Reinstall top cover and screws (10). Install transfer valve knob.

k. Return the actuator to service.

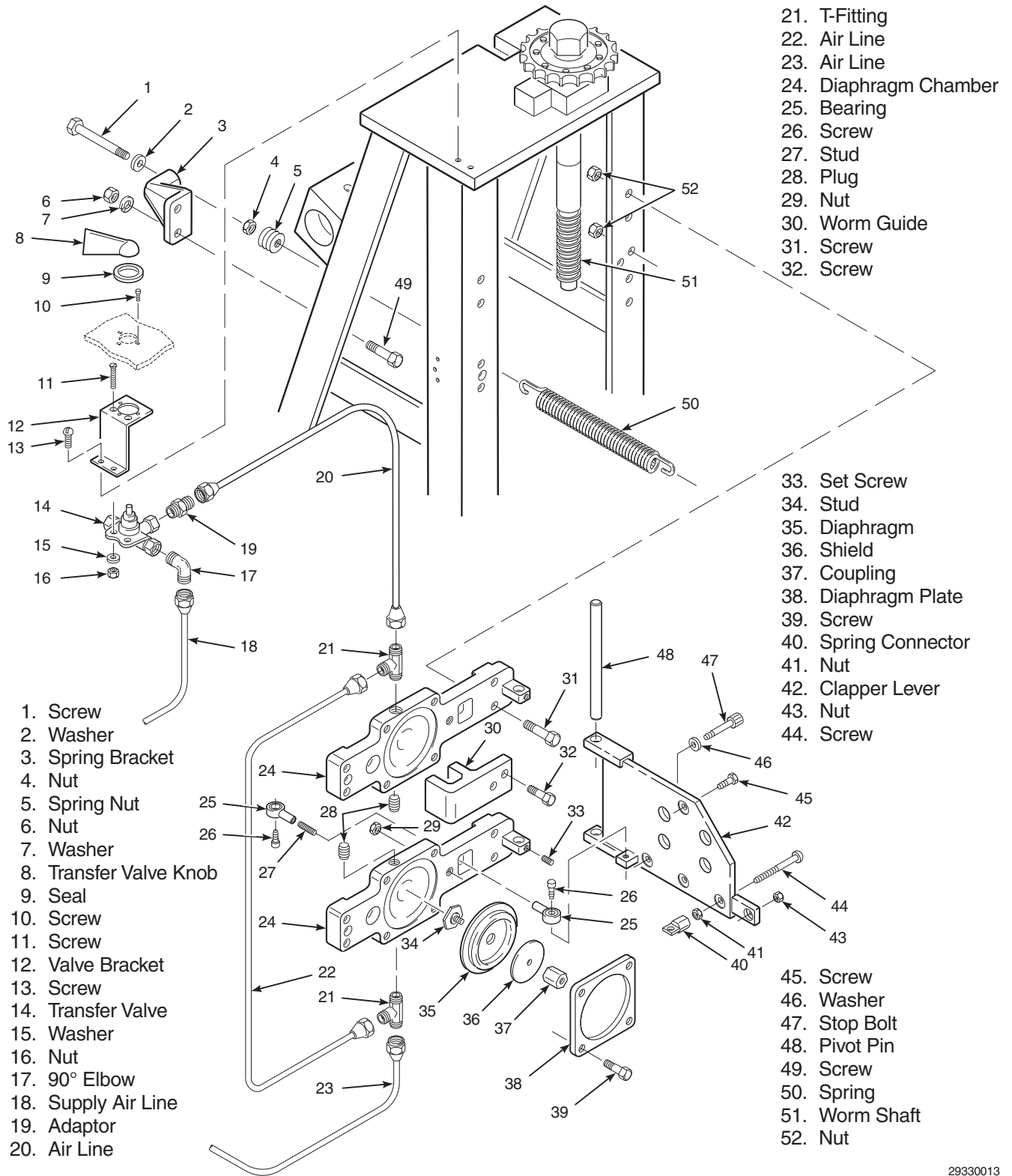

Figure 7-2. Mechanical Air Lock and Transfer Valve

29330013

7-6. **REVERSE RELAY.** Use the following procedure for replacement of a faulty reverse relay.

- a. Shut off actuator air supply and electronic signals. If unit has air lock feature, place transfer valve in manual position.
- b. Refer to Figure 7-3. Label all air lines for proper positioning on reassembly.
- c. Loosen supply air lines (2) and DVC5000 air lines (3) to bleed residual air.
- d. Disconnect supply air lines (2), DVC5000 air lines (3), and cylinder air line (4) at fittings (5, 6, and 7).

- e. Remove screws (1). Remove reverse relay (8).
- f. Remove fittings (5, 6, and 7). Install fittings in same locations on replacement reverse relay.
- g. Install replacement reverse relay (8) on mounting bracket (9) with screws (1).
- h. Reinstall supply air lines (2), DVC5000 air lines (3), and cylinder air line (4) to their proper fittings.
- i. Calibrate the reverse relay according to paragraph 4-1.

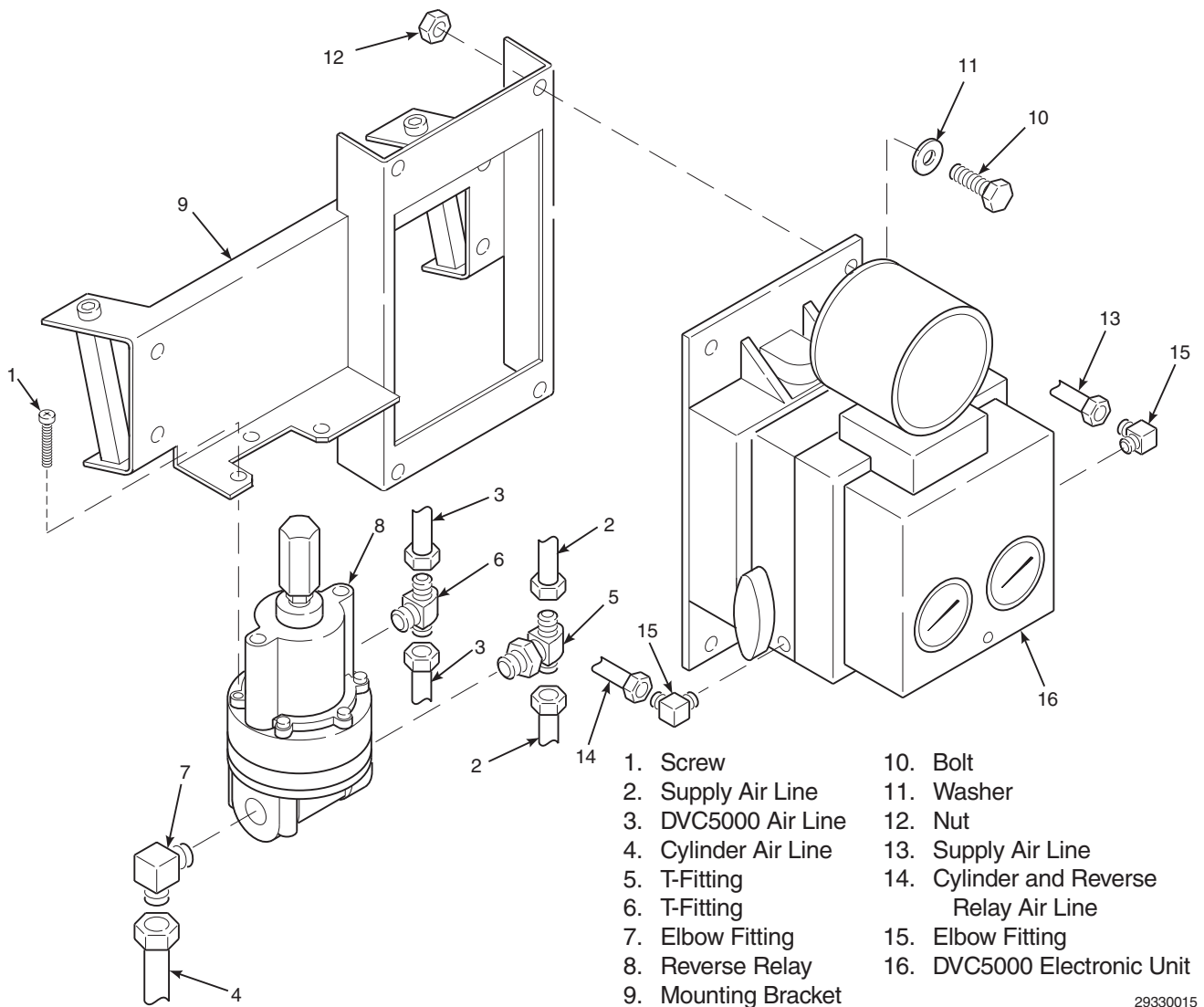

Figure 7-3. Reverse Relay and DVC5000 Electronic Unit Replacement

7-7. **DVC5000 ELECTRONIC UNIT.** Use the following procedure for replacement of a faulty DVC5000 electronic unit.

- a. Shut off actuator air supply and electronic signals. If unit has air lock feature, place transfer valve in manual position.
- b. Disconnect any electrical leads to the DVC5000 terminal.
- c. Refer to Figure 7-3. Label all air lines for proper positioning on reassembly.
- d. Loosen supply air line (13) and cylinder and reverse relay air line (14) to bleed residual air.
- e. Disconnect supply air line (13) and cylinder and reverse relay air line (14) at elbow fittings (15).

NOTE

Before removing DVC5000 electronic unit, note position of cam follower arm roller contacting cam on actuator shaft so cam follower arm roller on new unit can be placed in same position.

- f. Remove four bolts (10), washers (11), and nuts (12) securing DVC5000 electronic unit (16) to mounting bracket (9). Remove DVC5000 electronic unit. Note position of cam follower arm

roller on cam assembly so position of cam follower arm roller on new unit can be placed in same position.

- g. Remove both elbow fittings (15). Install fittings in same locations on replacement DVC5000 electronic unit (16).

NOTE

Install replacement DVC5000 electronic unit so that the cam follower arm roller contacts the cam mounted on the actuator shaft in the same position as the old unit.

- h. Install replacement DVC5000 electronic unit (16) on mounting bracket (9) with four bolts (10), washers (11), and nuts (12). Ensure cam follower arm roller extending from the bottom of the unit contacts the cam on the actuator shaft in the same position as the old unit.
- i. Reinstall supply air line (13) and cylinder and reverse relay air line (14) to their proper locations.
- j. If using ValveLink software, configuration data can be saved and downloaded from replaced unit.
- k. Refer to the FIELDVUE DVC5000 Series Digital Valve Controller Instruction Manual sections 4 and 6 to calibrate the DVC5000 electronic unit.

7-8. **DVC6000 ELECTRONIC UNIT.** Use the following procedure to replace the DVC6000 electronic unit.

- a. Shut off actuator air supply and electronic signals. If unit has air lock feature, place transfer valve in manual position.
- b. Disconnect electrical leads to the DVC6000.
- c. Refer to Figure 7-4. Label all air lines for proper positioning on reassembly.
- d. Loosen supply air line (1) and cylinder air lines (2) to bleed residual air.
- e. Disconnect supply air line (1) and cylinder air lines (2) at elbow fittings (3).

NOTE

Before removing DVC6000 electronic unit, mark contact point of cam follower on cam so cam follower roller can be placed in same position when new unit is installed.

- f. Remove four bolts (4), washers (5), and nuts (6) securing DVC6000 electronic unit (7) to mounting bracket (8). Remove DVC6000 electronic unit. Note position of cam follower arm roller on cam assembly so cam follower on new unit can be placed in same position.
- g. Remove elbow fittings (3). Install fittings in same locations on replacement DVC6000 electronic unit (7).

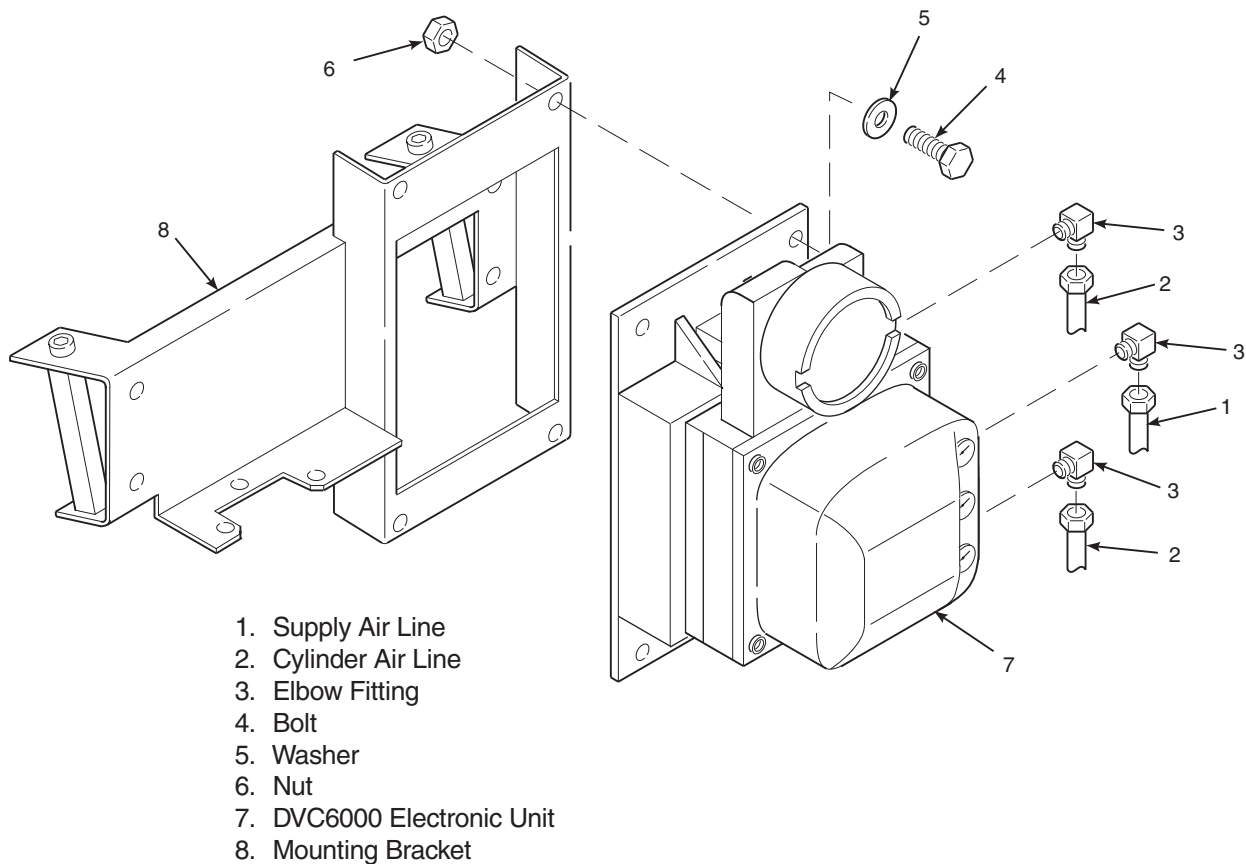

35340007

Figure 7-4. DVC6000 Electronic Unit Replacement

NOTE

Install replacement DVC6000 electronic unit so that the cam follower roller contacts the actuator shaft cam in the same position as the old unit.

- h. Install replacement DVC6000 electronic unit (7) on mounting bracket (8) with four bolts (4), washers (5), and nuts (6). Ensure cam follower arm roller extending from the bottom of the unit contacts the cam on the actuator shaft in the same position as the old unit.
- i. Reinstall supply air line (1) and cylinder air line (2) to their proper locations.
- j. If using ValveLink software, configuration data can be saved and downloaded from replaced unit.
- k. Refer to the FIELDVUE DVC6000 Series Digital Valve Controller Instruction Manual Sections 4 and 6 to calibrate the DVC6000 electronic unit.

7-9. SHAFT BUSHINGS. Use the following procedure to replace shaft bushings.

WARNING

Before performing any maintenance or repair action on actuator, shut off supply air and any electronic signals to actuator. Isolate actuator from all systems connected to the actuator. Severe injury or death may result from large torque produced by actuator.

- a. Remove actuator from service and isolate air to the unit.
- b. Move transfer valve to automatic position and prop air lock clapper lever open.
- c. Remove screws (13, Figure 7-5), sector gear (14), and key (12) from shaft (20).

- | | |
|-------------------------|--------------------|
| 1. Retaining Ring | 11. Cylinder Lever |
| 2. Clevis Pin | 12. Key |
| 3. Clevis | 13. Screw |
| 4. Linkage Lever | 14. Sector Gear |
| 5. Screw | 15. Spacer |
| 6. Screw | 16. Felt Gasket |
| 7. Cam Mounting Bracket | 17. Tube Sleeve |
| 8. Screw | 18. Grease Fitting |
| 9. Cam | 19. Shaft Bushing |
| 10. Screw | 20. Shaft |

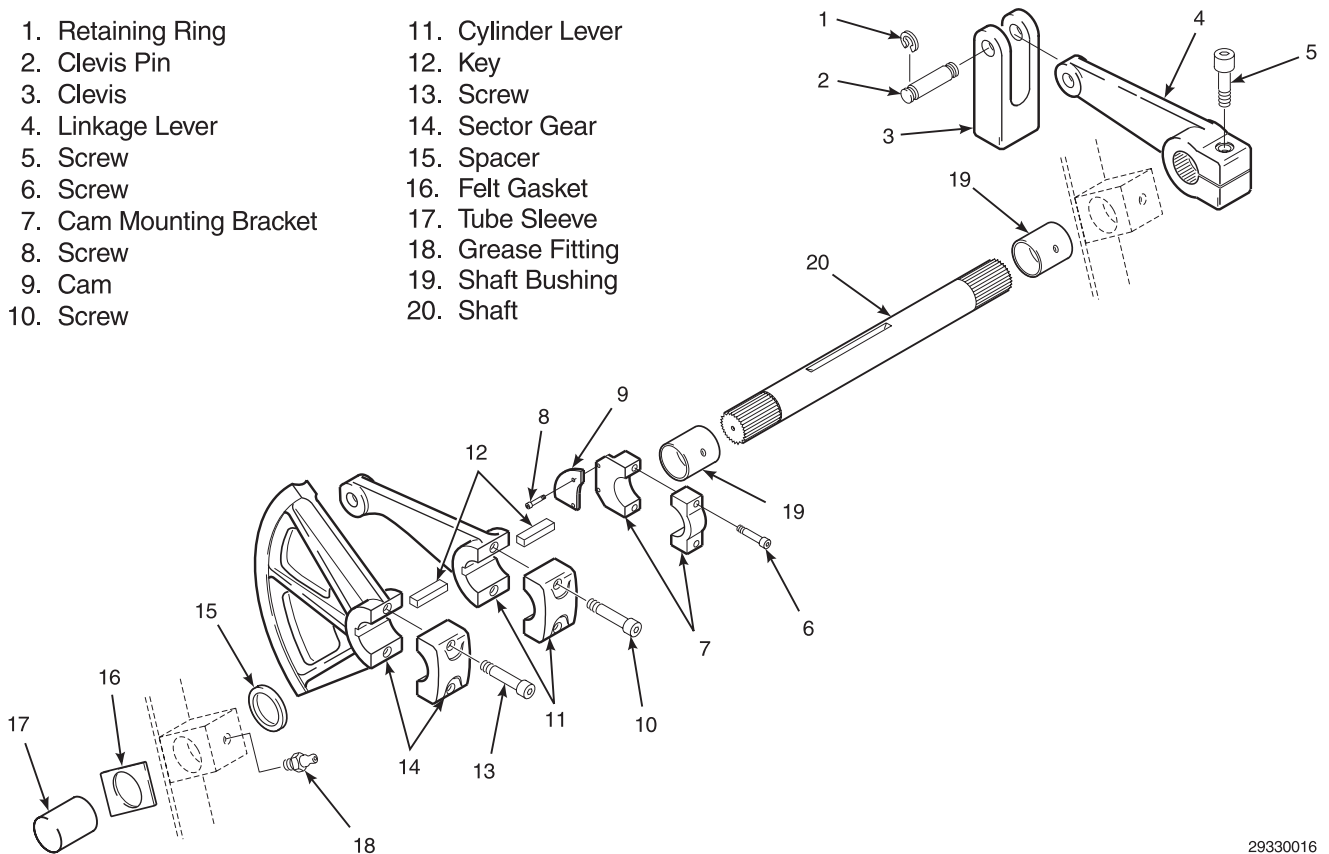

Figure 7-5. Shaft Exploded View

29330016

- d. Remove screws (10), cylinder lever (11) and key (12) from shaft (20).
- e. Remove screw (5) and linkage lever (4) from shaft (20).
- f. Remove screws (6) and cam mounting bracket (7) from shaft (20).
- g. Pull one end of shaft (20) and remove shaft from the bushing blocks. Remove spacer (15).
- h. Remove grease fitting (18) from bushing block.
- i. Break seal by pounding on shaft bushing (19). Remove shaft bushing from bushing block.

WARNING

Use caution and appropriate safety equipment when applying Loctite. Make sure all specific instructions on Material Safety Data Sheet (MSDS) are followed. Failure to do so may cause severe eye injury.

CAUTION

Care must be used when applying Loctite primer or adhesive to bushings to make sure it is applied only to the outer surface. Bushing life may be reduced.

NOTE

Bushings are secured to stand assembly with a coating of Loctite applied to the outside of bushings and complete installation of shaft assembly must be completed before

Loctite sets. This is needed to line up bushings properly. The Loctite will set in approximately 3 minutes. Complete the installation of shaft assembly within 15 minutes from when adhesive was applied.

- j. Apply Loctite primer (11NA79001A30) to outside surface of shaft bushing (19). Allow primer to set for 3 to 5 minutes.
- k. After primer has set for 3 to 5 minutes, apply Loctite adhesive #680 and slide shaft bushing (19) into bushing block within 3 minutes.
- l. Insert shaft (20) through both bushing blocks to align bushings.
- m. Allow Loctite to set for 15 minutes. Remove shaft (20) and drill a 5/16 in. hole into new shaft bushing through the bushing block.
- n. Insert shaft through both bushing blocks and spacer (15) as shown in Figure 7-5.
- o. Install cam mounting bracket (7).
- p. Install linkage lever (4).
- q. Install cylinder lever (11) and sector gear (14) using keys (30).
- r. Remove prop from clapper lever.
- s. Refer to Section VI, Periodic Maintenance, and lubricate actuator shaft bushings.
- t. Refer to the FIELDVUE DVC5000/6000 Series Digital Valve Controller Instruction Manual and calibrate the DVC5000/6000 electronic unit.
- u. Return the actuator to service.

SECTION VIII. OPTIONS

8-1. OVERVIEW. The options for the PowerVUE Model PVD 814 fan/damper actuator covered in this section include limit switches, heater/thermostat, and SPA with HART alarm.

8-2. LIMIT SWITCHES.

a. Adjustment.

WARNING

Before performing any maintenance or repair action on the actuator, shut off supply air and any electrical supply or electronic signals to the actuator. Isolate actuator from all systems connected to the actuator. Severe injury or death may result from large torque produced by actuator.

1. Remove actuator from service, close supply air shutoff valve, and isolate any electrical supply or electronic signals to actuator.
2. Loosen screws (1, Figure 8-1) securing upper limit switch cam assembly (2) to shaft (3).
3. Use manual operator wheel to position linkage lever to desired upper limit stopping position.
4. Rotate upper limit switch cam in counterclockwise direction when viewed from left of actuator. When cam shoe engages upper limit switch (4), secure cam assembly (2) to shaft (3) with screws (1).
5. Loosen screws (5) securing lower limit switch cam assembly (6) to shaft (3).

6. Use manual operator wheel to position linkage lever to lower limit stopping position.

7. Rotate lower limit switch cam assembly (6) in counterclockwise direction when viewed from left of actuator. When cam shoe engages lower limit switch (7), secure cam assembly (6) to shaft (3) with screws (5).

b. Replacement.

1. Remove actuator from service, close supply air shutoff valve, and disconnect any electrical supply and electronic signals to actuator.
2. Disconnect limit switch wires from terminals 1 through 8 on terminal blocks 2 and 3 in junction box.
3. Remove nuts (9, Figure 8-1) from studs (8) and remove studs.
4. Remove lower limit switch (7) and upper limit switch (4) from bracket.
5. Install new switches on bracket with studs (8) and nuts (9).
6. Route wires along same path as old limit switches. Connect wires from new switches to terminal blocks 2 and 3 as shown in Figure 8-1.
7. Restore electrical supply and electronic signals to actuator. Open supply air shutoff valve.
8. Refer to paragraph 8-2a. and adjust limit switches. Return actuator to service.

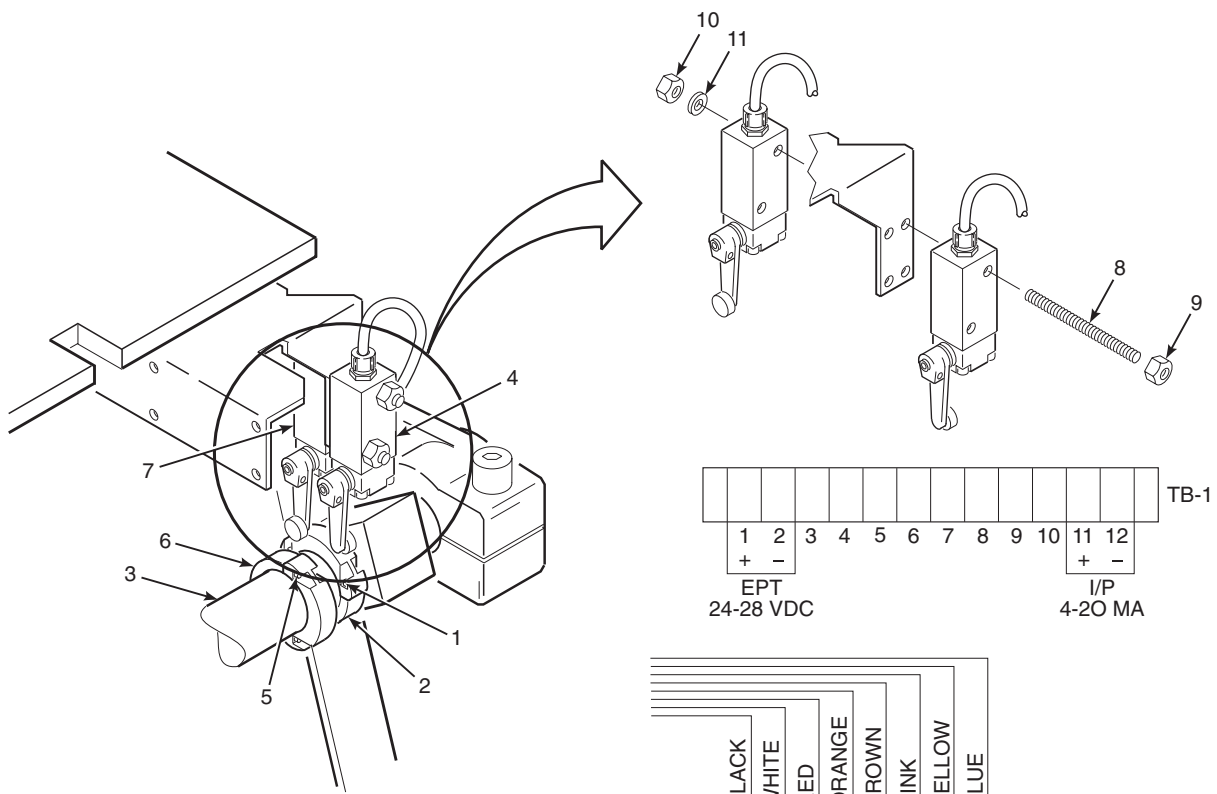

1. Screws
2. Cam Assembly
3. Shaft
4. Upper Limit Switch
5. Screws
6. Cam Assembly
7. Lower Limit Switch
8. Stud
9. Nut
10. Nut
11. Washer

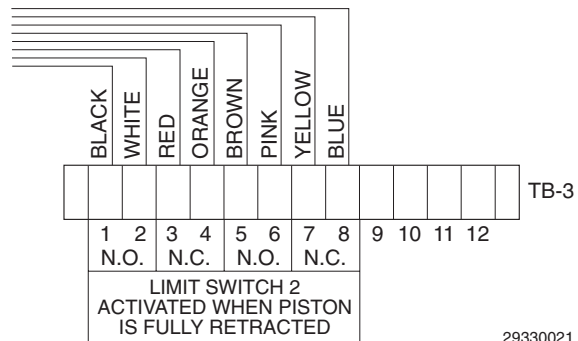
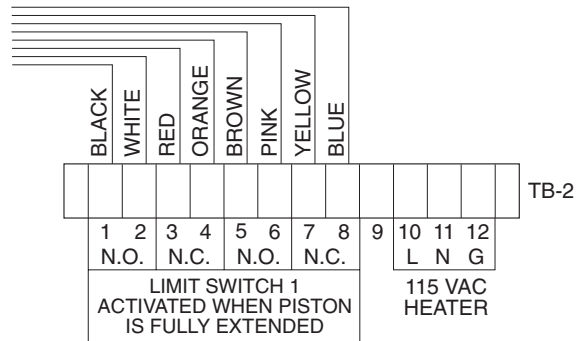
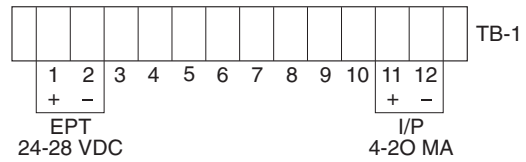

29330021

Figure 8-1. Limit Switch Exploded View

- 8-3. **HEATER/THERMOSTAT.** Refer to Figure 8-2 and the following procedure to replace the heater/thermostat.

WARNING

Before performing any maintenance or repair action on the actuator, shut off supply air and any or electronic signals to the actuator. Isolate actuator from all systems connected to the actuator. Severe injury or death may result from large torque produced by actuator.

a. Heater Replacement.

1. Remove actuator from service, close air supply shutoff valve, and isolate electronic signals from actuator.

b. Thermostat Replacement.

1. Remove actuator from service, close air supply shutoff valve, and isolate electronic signals from actuator.
2. Remove terminal cover screws (7) and terminal cover (8). Remove thermostat lead (9) from terminal 1 on terminal block (12).
3. Remove screws (17) and heater socket (16) from mounting plate (10). Remove thermostat lead (9) from heater socket.

1. Screw
2. Lockwasher
3. Thermostat
4. Nut
5. Lockwasher
6. Screw
7. Screw
8. Terminal Cover
9. Thermostat Lead
10. Mounting Plate
11. Backing Plate
12. Terminal Block
13. Screw
14. Heater Lead
15. Thermostat Lead
16. Heater Socket
17. Screw
18. Heating Element
19. Nut

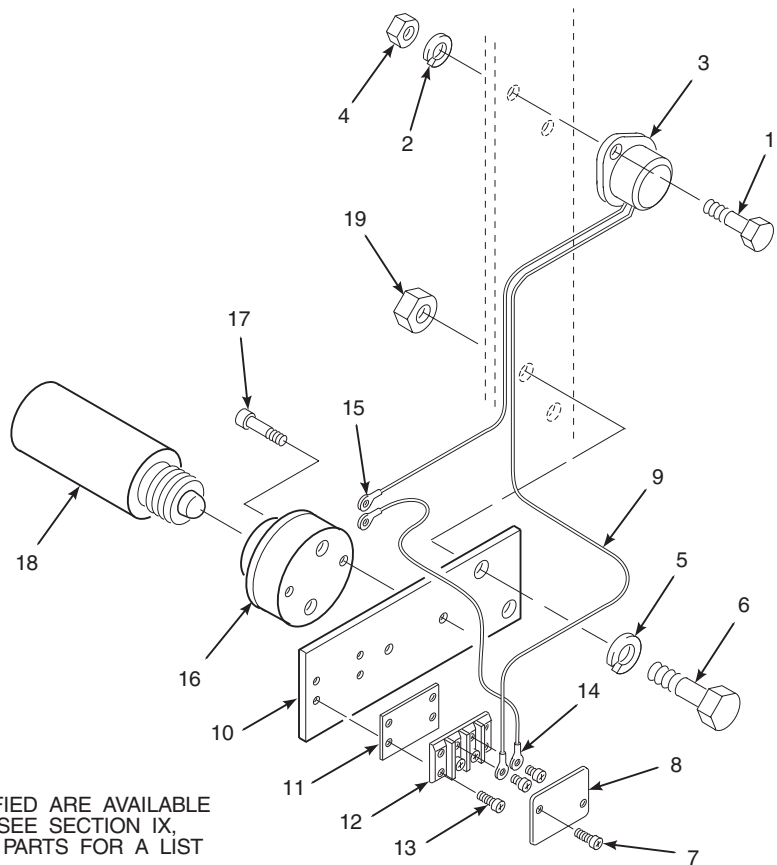

NOTE: NOT ALL ITEMS IDENTIFIED ARE AVAILABLE FOR INDIVIDUAL SALE. SEE SECTION IX, RECOMMENDED SPARE PARTS FOR A LIST OF AVAILABLE PARTS.

29330017

Figure 8-2. Heater/Thermostat

4. Remove screws (1), lockwashers (2), nuts (4), and thermostat (3) from frame.
5. Install new thermostat (3) with screws (1), lockwashers (2), and nuts (4) on frame.
6. Connect thermostat lead (9) to heater socket (16) and reinstall heater socket with screws (17).
7. Install terminal cover (8) with screws (7).
8. Restore electronic signals and return actuator to service.

8-4. **HART Site Programmable Alarm (DVC6000 Series Controller only).**

- a. **Overview.** The DVC6000 series valve controller includes a cam-driven position potentiometer to provide feedback information about actuator position. The position transmitter is the source of all discrete and absolute position information for the valve controller. The feedback information is transmitted via HART communications from the control room to the DVC6000 controller.

Some users, however, want an independent position feedback to confirm the actuator position. The Moore Industries HART Site Programmable Alarm (SPA) option provides this independent position feedback.

- b. **Capabilities.** The HART Site Programmable Alarm is provided for customers that want independent confirmation of actuator position. The SPA communicates via HART and can initiate the following actions based on the digital position signal:

1. Retransmit a single 4-20 mA position signal. Many users want this capability to represent or record the PowerVUE position.
2. Initiate 2 or 3 contact closures based on actuator position.
3. Initiate a contact closure on the loss of HART communications or on a predetermined set of SPA fault conditions.

- c. **Installation.** The SPA is a ¼ DIN electronic module that can be mounted near the control room in the cabinetry where I/O terminations are located. The SPA should be wired in parallel to the 4-20 mA control signal routed from the control room to the DVC6000.

- d. **Setup.** Install and set up the DVC6000 completely before setting up the SPA unit. Instructions for setting up the SPA are included in the Moore Instruction Manual, 224-741-00B.

Recommended values for this sample setup are as follows:

1. Dip Switch Settings.

Password – no recommendation
(user decide)
Failsafe/Non-Failsafe – non-failsafe
Current Source, Sink, or Voltage
– set to Current Source

2. Relay Setup.

Relay #1 – HART alarm:

Set to Primary vs. Secondary
Set to Normal vs. Burst
Set “Number of variables” to 1
(factory default)
Set “Number of Trys” to 1
(factory default)
Set “HART Source” settings to:
Bit 7 on
Bit 5 off
Bit 4 off
Bit 3 on
Bit 2 on
Bit 1 off
Bit 0 on

Alarm Source Information, Relays 2,3,4:

Set “Analog Output Source” to
PV (process variable)
Set “Relay Sources” to PV

Configuring Miscellaneous Options:

Set linearization off – “LINR OFF”
Set Scaling to “AUTO”
Set Engineering Units to “PCT”
Set Source for SPA display to PV
Set function of Relay #2 to
“TRIP” vs. “FAULT”
Set Upscale/Downscale Drive to
“LOW”

Setting Engineering Units:

Set "PCT" for all
Smart Scaling – do not use
Scaling the HART input – complete
this procedure
Customizing Input Linearization
– do not use
Smart Scaling of SPA Analog
Output – complete this procedure
Trimming the SPA Analog Output –
complete this procedure

Configuring the SPA Relays per the
"Flame Safety Interface" example:

Alarm #2:

Enter Trip – Set to 95%
(input trip is inactive)
Deadband – Set to "0"
Delay – Set to "0 sec"
Hi/Lo Alarm Function –
Set for "Hi"
Latching – Set to "OFF"

Alarm #3:

Input Trip – Set 22%
(2nd input trip inactive)
Deadband – Set to "0"
Delay – Set to "0 sec"
Hi/Lo Alarm Function –
Set to "Lo"
Latching – Set to "OFF"

Alarm #4:

Input Trip – Set to 18%
(2nd input trip is inactive)
Deadband – Set to "0"
Delay – Set to "0 sec"
Hi/Lo Alarm Function –
Set to "Hi"
Latching – Set to "OFF"

- e. **Limit Switch Function.** Traditionally, limit switches were tripped upon contact with a cam on the rotary output shaft of the actuator. The lobe of the cam caused switch actuation for 10 to 20% of the rotary travel of the actuator shaft.

The SPA unit receives actuator position data via HART communications and controls two relays based on the digital position signal. (The SPA unit initiates contact closure when the Power-VUE travel is above or below a given position only. Two contact closures are used to confirm a given position or range.)

The following "flame safety interface" example illustrates how to set up the unit for an operation wherein the relay contact closures control an automated boiler light-off system. Refer to the timing chart and wiring diagram shown in Figures 8-3 and 8-4.

1. User wishes to confirm that actuator is above 95% (purge). Contact #2 is normally open and closes at or above 95%.
2. User wishes to confirm that actuator is at 22% of travel (light-off). Contact #3 is normally open and closes below 22%. Contact #4 is normally open and closes above 18%. The two contacts must both be closed in order for the resultant contact to close, confirming actuator position between 18 and 22% (light-off).

Using contacts #1 and #2, any failure within the SPA unit will cause outputs to go to a default value. In this example, all contacts fail to the open position. The contacts are also wired such that a fault can be indicated to the user.

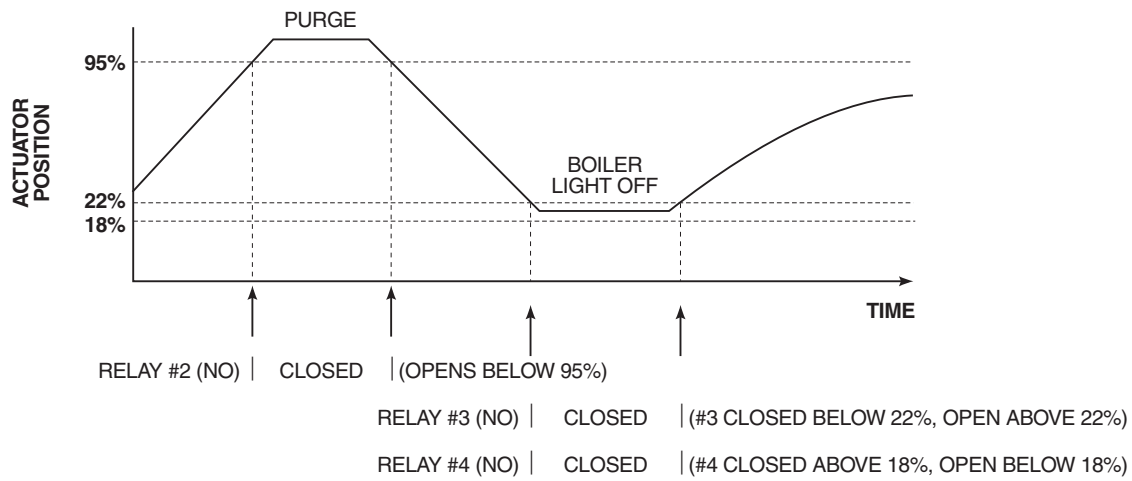

35340007

Figure 8-3. Timing Chart for Flame Safety Application

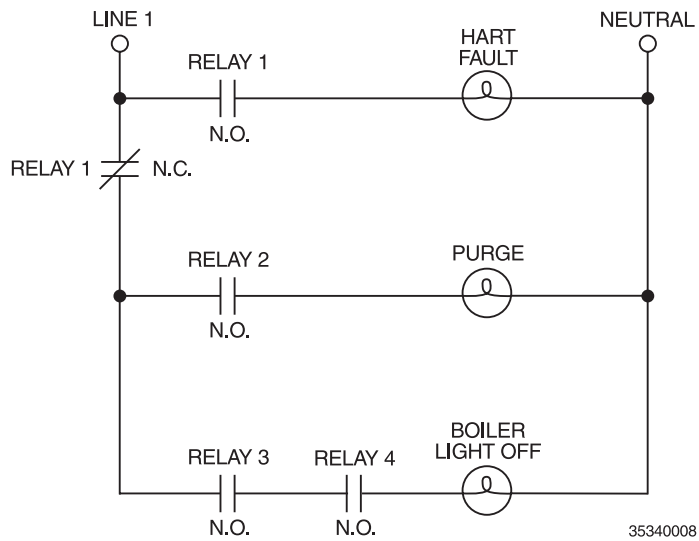

Figure 8-4. Wiring Schematic for Flame Safety Application

SECTION IX. RECOMMENDED SPARE PARTS

NOTE

Refer to FIELDVIEW DVC5000/6000 Series Digital Valve Controller Instruction Manual, Section 10 for parts information for the DVC5000 or DVC6000 electronic unit.

Table 9-1. Recommended Spare Parts for PowerVUE Model PVD 814 Fan/Damper Actuator

FIGURE and INDEX NUMBER	PART NUMBER	DESCRIPTION	QTY
Not Shown	1A97803G02	Spare Parts Kit 8 x 14 Actuator	1
7-1, 22		O-ring (120039-016)	1
7-1, 24		O-ring (120039-032)	1
7-1, 18		Gasket (141279)	1
7-1, 28		Gasket (141279)	1
7-1, 25		Piston (24128)	1
6-2, 21		Rod Packing Parts (2831A95G01)	1
7-2, 35		Air Lock Diaphragm (9351-003)	2
7-1, 25	1A97803G04	Spare Parts Kit, Piston (241282)	1
6-2, 21	1A97803G05	Spare Parts Kit, Rod Packing (2831A95G01)	15
7-1, 22	1A97803G08	Spare Parts Kit, O-ring (120039-016)	50
7-1, 24	1A97803G09	Spare Parts Kit, O-ring (120039-032)	50
7-1, 18, 28	1A97803G10	Spare Parts Kit, Gasket (141279)	25
6-1	183512	Grease, MoS ₂ -793, 4 lb (1.8 kg) can	A/R
7-1, 23	342371	Piston Follower	1
1-1, 3	IB-102-208P	8 x 14 PowerVUE Instruction Bulletin	1
5-1	161433	Pneumatic Trip Valve	1
1-1, 2	372538-002	Air Filter	1
Not Shown	372538-023	Air Filter Element	1

Table 9-2. Recommended Spare Parts for Options (PowerVUE Model PVD 814 Fan/Damper Actuator Only)

FIGURE and INDEX NUMBER	PART NUMBER	DESCRIPTION	QTY
8-2, 18	153407-001	Heating Element (150 Watt)	1
8-2, 16	256996	Heater Socket	1
8-2, 16	145822	Porcelain Receptacle	1
8-2, 3	153408	Thermostat	1
8-2, 8	114656	Terminal Cover	1
8-2, 10	157030	Mounting Plate	1
8-2, 11	143650-006	Terminal Marker Strip	1
8-2, 11	181404-002	Terminal Marker Strip	1
8-2, 12	181403-002	Terminal Block	1
7-2, 14	141187	Transfer Valve	1
7-2	457829	Air Lock Assembly	1
7-2, 24	342376	Diaphragm Chamber	2
7-2, 38	242406	Diaphragm Plate	2
7-2, 35	9351-003	Diaphragm	2
7-2, 34	141168-005	Stud	2
7-2, 36	141168-004	Shield	2
7-2, 42	357720	Clapper Lever	1
7-2, 48	157704	Pivot Pin	1
7-2, 20	125368-009	Air Line	1
7-2, 22	125368-007	Air Line	1

SECTION X. RETURNING EQUIPMENT TO THE FACTORY

10-1. If factory repair of defective equipment is required, proceed as follows:

- a.** Secure a return authorization from a Rosemount Analytical Sales Office or Representative before returning the equipment. Equipment must be returned with complete identification in accordance with Rosemount instructions or it will not be accepted.

In no event will Rosemount be responsible for equipment without proper authorization and identification.

- b.** Carefully pack defective unit in a sturdy box with sufficient shock absorbing material to ensure no additional damage will occur during shipping.
- c.** In a cover letter, describe completely:
 - 1. The symptoms that determined the equipment is faulty.
 - 2. The environment in which the equipment was operating (housing, weather, vibration, dust, etc.).
 - 3. Site from which equipment was removed.

4. Whether warranty service or nonwarranty service is requested.

5. Complete shipping instructions for the return of the equipment.

- d.** Enclose a cover letter and purchase order and ship the defective equipment according to instructions provided in a Rosemount Return Authorization, prepaid, to:

Rosemount Analytical Inc.
RMR Department
1201 N. Main Street
Orrville, Ohio 44667

If warranty service is requested, the defective unit will be carefully inspected and tested at the factory. If failure was due to conditions listed in the standard Rosemount warranty, the defective unit will be repaired or replaced at Rosemount's option, and an operating unit will be returned to the customer in accordance with shipping instructions furnished in the cover letter.

For equipment no longer under warranty, the equipment will be repaired at the factory and returned as directed by the purchase order and shipping instructions.

INDEX

This index is an alphabetized listing of parts, terms, and procedures having to do with the PowerVUE Model PVD 814 fan/damper actuator. Every item listed in this index refers to a location in the manual by one or more page numbers.

A

- Actuator Features, 1-1
- Actuator Mounting, 2-2
- Actuator Operation, 1-2, 1-3
- Actuator Options, 1-1, 1-2
- Actuator Piping Diagram, 5-1
- Air Filter, 1-2
- Air Lock, 1-2
- Air Lock, Adjustment, 6-4
- Air Piping Schematic, 2-3
- Air Supply Installation, 2-3
- Air Supply Requirements, 1-5, 2-3

C

- Calibration
 - DVC5000/6000 Electronic Unit, 4-1
 - Reverse Relay, 4-1
- Clearance Requirements, 2-2
- Clevis, 1-2
- Corrective Maintenance
 - Air Lock Diaphragm, 7-4
 - Cylinder Replacement, 7-3
 - DVC5000 Electronic Unit, 7-7
 - DVC6000 Electronic Unit, 7-8
 - Heater/Thermostat, 8-3
 - Reverse Relay, 7-6
 - Shaft Bushings, 7-9
 - Transfer Valve, 7-4

D

- Digital Communications, 1-2
- Direction of Rotation, 1-2
- DVC5000/6000 Electronic Unit, 1-1, 1-2

E

- Electronic Unit Replacement, DVC5000, 7-7
- Electronic Unit Replacement, DVC6000, 7-8
- Environmental Requirements, 1-5

H

- Handwheel, 1-1
- Heater/Thermostat, 1-2

I

- Installation
 - Air Supply, 2-3
 - Linkage, 2-4
 - Special Considerations, 2-1

L

- Linkage Cleaning and Lubrication, 6-4
- Linkage Design, Special Installation Considerations, 2-1
- Linkage Installation, 2-4
- Lubrication Chart, 6-0

M

- Maintenance Schedule, 6-1
- Mechanical Air Lock, 1-1
- Model Number Matrix, 1-0
- Mounting Instructions, 2-2

P

- Package Contents, 1-1
- Periodic Maintenance
 - Cylinder, 6-2
 - General, 6-1
 - Piston, 6-2

R

- Recommended Spare Parts, 9-1
- Reverse Relay, 4-1

S

- Signal Requirements, 1-5
- Site Programmable Alarm, 8-4
- Specifications, Actuator, 1-5
- Specifications, Rust Preventative Compound, 1-6
- Storage Instructions, 1-6

T

- Transfer Valve, 1-2
- Troubleshooting, 5-1

Appendix A
PowerVUE™
FAN/DAMPER ACTUATOR
TORQUE TYPE 8 x 14
for use with DVC5000 Series
DIGITAL VALVE CONTROLLER

RETROFIT KIT
INSTALLATION INSTRUCTIONS

Instruction Bulletin IB-102-208P Rev. 1.0

ROSEMOUNT® ANALYTICAL

FISHER-ROSEMOUNT™

TABLE OF CONTENTS

Section	Page
A. RETROFIT KIT INSTALLATION INSTRUCTIONS.....	A-1
A-1. Forward.....	A-1
A-2. Component Checklist.....	A-1
A-3. Overview.....	A-1
A-4. Mechanical Installation.....	A-2
A-5. DVC5000 Electronic Setup	A-7
A-6. Calibration	A-7

LIST OF ILLUSTRATIONS

Figure	Page
A-1	PowerVUE 8 x 14 Retrofit Kit..... iv
A-2	Retrofitted PowerVUE 8 x 14 Actuator A-1
A-3	8 x 14 Actuator (with Side Panels) A-2
A-4	Air Tubing and Positioner System (Pre-retrofit)..... A-3
A-5	Component Removal A-4
A-6	PowerVUE Component Installation..... A-5
A-7	Air Piping Diagram (with Mechanical Air Lock Option) A-6

Table A-1. Model Number Matrix

PowerVUE Retrofit Kit - ORDERING INFORMATION

Select complete model number from the Model Number Matrix.

PVD 468R	PowerVUE Drive⁽¹⁾			
	Code	Model		
	01	4 x 5		
	02	8 x 14 ⁽²⁾		
	Code	Digital Valve Controller		
	00	None ⁽³⁾		
	01	HART ⁽⁴⁾ DVC6000		
	02	Fieldbus ⁽⁵⁾ DVC5000, with Basic Control Suite		
	03	Fieldbus ⁽⁵⁾ DVC5000f, without Basic Control Suite		
	04	Other DVC Style Selected ⁽⁶⁾		
	Code	EPT		
	00	None		
	01	Digital EPT and 2 Limit Contacts (HART versions only) ⁽⁷⁾		
PVD 468R	02	02	01	EXAMPLE

NOTES:

- Performance and specifications may vary from the published specifications, depending on the age of the Hagan fan/damper actuator and the quality of the DVC5000/6000 installation. Setup and calibration is the responsibility of others. Faichild reversing relay is included with or without (selection of) DVC5000.
- Some rilling and tapping required. Existing covers may be modified in the field or a precut back cover can be selected (reference P/N 4851B28G01).
- Digital Valve Controller (DVC5000/6000) may be supplied by others, but no performance quarantees for accuracy or speeds of response are provided. Warranty for DVC5000/6000 will be the responsibility of the provider. Tubing is provided, but is not precut or preformed.
- Standard arrangement calls for Model DVC6020f-516G60, certified to FM as intrinsically safe, and Division 2. Other certifications are available. Advanced diagnostics provided.
- Standard arrangement calls for Model DVC5020f-216, certified to FM as intrinsically safe, and Division 2. Other certifications are available. Advanced diagnostics provided.
- Designate other DVC5020/6020 model number as a note on order.
- Utilizes Moore Industries Site Programmable HART Alarm.
 Default configuration:
 1 analog output representing actuator travel
 3 customer selectable position contacts
 1 contact for Field Device Failure
 Moore HART SPA may be configured in an intrinsically safe arrangement through an IS barrier.

DVC5000/6000 Options:
 Flameproof cable gland: 1/2" NPT (aluminum), EExd IIC
 Cable entry adaptor (brass): 1/2" NPT M20 x 1.5 ISO
 1/2" NPT, PG 13.5

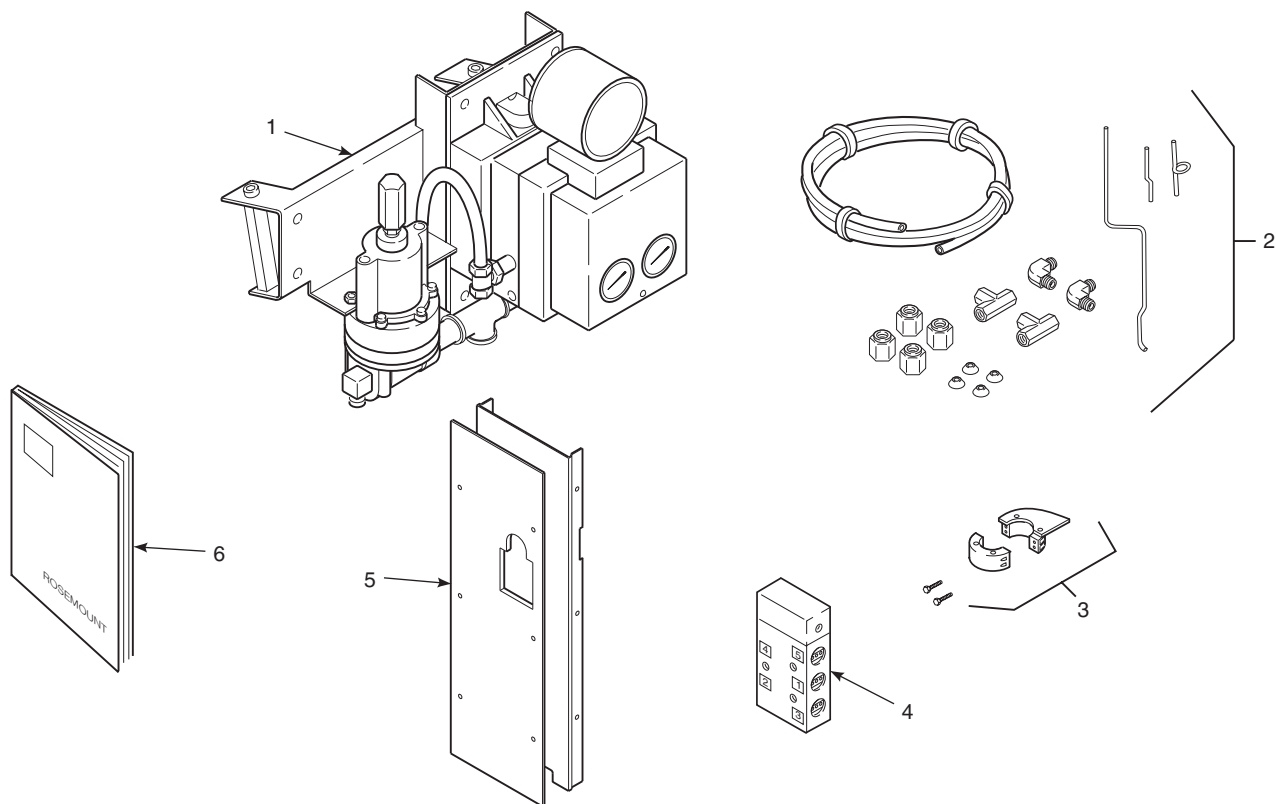

NOTE: PowerVUE RETROFIT SUBASSEMBLY INCLUDES DVC5000 ELECTRONIC UNIT, REVERSE RELAY, MOUNTING BRACKET, MOUNTING BLOCKS, HARDWARE, AND CONNECTING AIR FITTINGS.

- | | |
|---|--|
| 1. PowerVUE Retrofit Subassembly | 4. Trip Valve |
| 2. Flexible Air Line Tubing Roll, Fitted Air Lines, Fittings and Connectors | 5. Side Panels (With Cutouts) |
| 3. Cam Assembly | 6. PowerVue 8x14 Actuator Instruction Bulletin with Retrofit Kit Installation Instructions |

29330022

Figure A-1. PowerVUE 8 x 14 Retrofit Kit

APPENDIX A. RETROFIT KIT INSTALLATION INSTRUCTIONS

- A-1. **FORWARD.** This appendix addresses how to replace an existing Hagan mechanical, pilot valve type, positioner system with a PowerVUE system. Removal, installation, and setup procedures are included. After completing this conversion, refer to the base sections of this instruction bulletin for future reference. The retrofit package includes a full instruction bulletin for the 8 x 14 PowerVUE Actuator. This instruction bulletin provides important information including startup, calibration, troubleshooting, and spare parts.

NOTE: ILLUSTRATED WITH
HANDWHEEL / MECHANICAL
AIR LOCK OPTION.

NOTE

The instruction bulletin for your existing power positioner (pre-retrofit) should be kept on file. Although Rosemount/Hagan continues to improve products and update instruction bulletins, the outdated instruction bulletin may still provide useful information.

- A-2. **COMPONENT CHECKLIST.** A typical PowerVUE 8 x 14 Actuator Retrofit Kit should contain the items shown in Figure A-1.
- A-3. **OVERVIEW.** The Rosemount PowerVUE 8 x 14 Actuator Retrofit Kit is designed for installation on the Hagan 8 x 14 Torque Type Power Positioner. The retrofit allows a 4-20 mA or fieldbus input signal sent by a user's process controller, to be received by the DVC5000 electronic unit. The DVC5000 electronic unit converts the input signal to a pneumatic output pressure which is sent to the top of the power cylinder and the reverse relay. The reverse relay sends the appropriate inverse air pressure to the bottom of the power cylinder locking the piston in place. A retrofitted PowerVUE 8 x 14 Actuator is shown in Figure A-1.

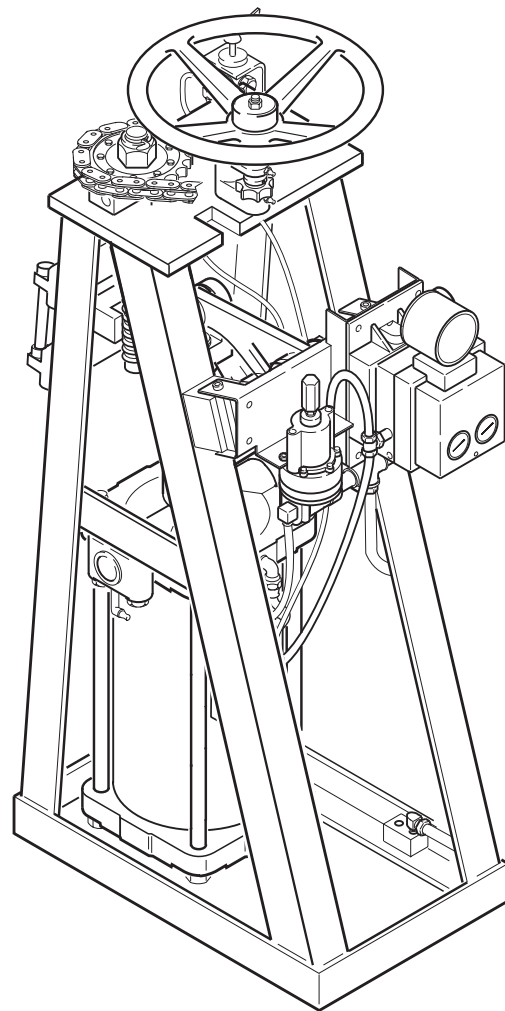

29330023

Figure A-1. Retrofitted PowerVUE 8 x 14 Actuator

A-4. MECHANICAL INSTALLATION.

WARNING

Before performing any retrofit actions on the actuator, isolate the actuator from all electrical and pneumatic systems. Severe injury or death may result from the large torque produced by the actuator.

a. Remove Actuator from Service.

NOTE

It is recommended that the actuator be decommissioned and moved prior to retrofitting the unit. Decommissioning and moving the unit will allow the removal of all covers, making component removal and installation much easier.

It is possible to complete the retrofit with the actuator in place. If the unit is to remain in place, use the “manual mode” of operation and remove all covers with the exception of the operating lever side cover.

1. Remove the actuator from service. Isolate the actuator from the air supply by disconnecting the air supply or closing the supply air shutoff valve (as applicable to the system). Isolate electrical power and electronic signals to the actuator.

2. Open the drain cock on the air filter to exhaust the air supply from the actuator.
3. If the unit is equipped with a transfer valve, place the transfer valve in the manual position (Figure A-2).
4. If leaving the unit in place during the retrofit, remove the side panels with the exception of the panel on the side of the operating lever.

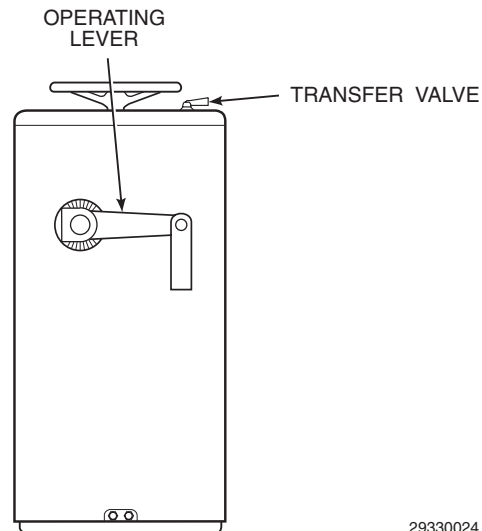

29330024

**Figure A-2. 8 x 14 Actuator
(with Side Panels)**

b. Remove Pneumatic Positioning Components.

NOTE

The limit switch assembly may be removed or reused. If removed, leave the outer cam saddle to serve as a thrust bearing.

The limit stop is not affected by the retrofit.

The heater/thermostat option is not affected by the retrofit.

The air lock option is not affected by the retrofit.

1. Disconnect and remove tubing from the diaphragm/spring assembly, pilot valve, and pilot valve manifold, Figure A-3.

2. Remove tubing and elbow fittings from the pneumatic cylinder.
3. Turn the handwheel counterclockwise to expose the pilot valve stem.
4. Unscrew the valve stem and separate the stem from the connecting link.
5. Remove cam assembly (1, Figure A-4) from shaft (2).
6. Remove the diaphragm/spring assembly (3) from the frame.
7. Remove the pilot valve/pilot valve manifold (4) from the frame.

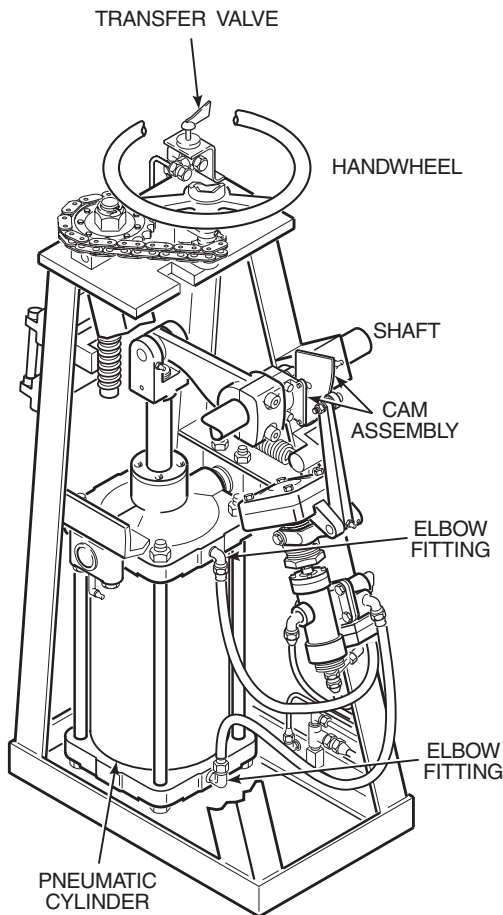

NOTE: ILLUSTRATED WITH HANDWHEEL/
MECHANICAL AIR LOCK OPTION.

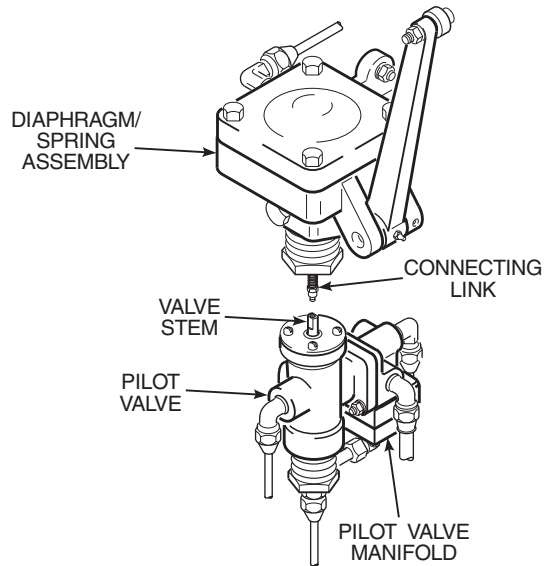

29330025

Figure A-3. Air Tubing and Positioner System (Pre-retrofit)

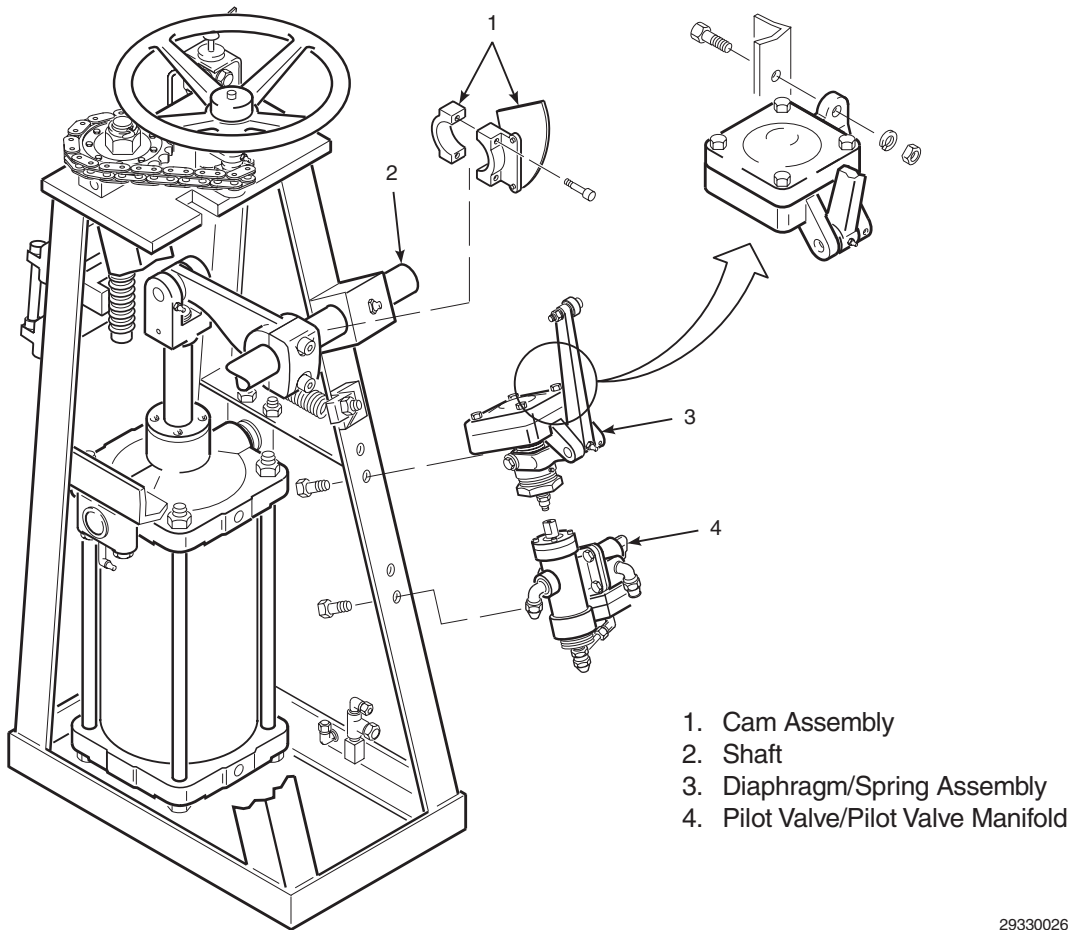

29330026

Figure A-4. Component Removal

c. Install PowerVUE Components.

NOTE

Before installing any PowerVUE retrofit components on the unit, ensure pneumatic cylinder piston is completely down.

1. Ensure pneumatic cylinder piston is completely down.
2. Install cam assembly to shaft, Figure A-5. Leave screws loose so cam rotates on shaft for later adjustment.
3. Hold up PowerVUE retrofit subassembly to bearing blocks and mark position of mounting blocks, Figure A-5.

CAUTION

Ensure weld splash does not damage actuator shaft, grease fittings, mounting hardware holes, or any other actuator components.

4. Remove mounting blocks from PowerVUE retrofit subassembly and weld to bearing blocks in marked positions. Ensure weld splash does not damage actuator components.
5. Install PowerVUE retrofit subassembly to mounting blocks with two allen screws provided.

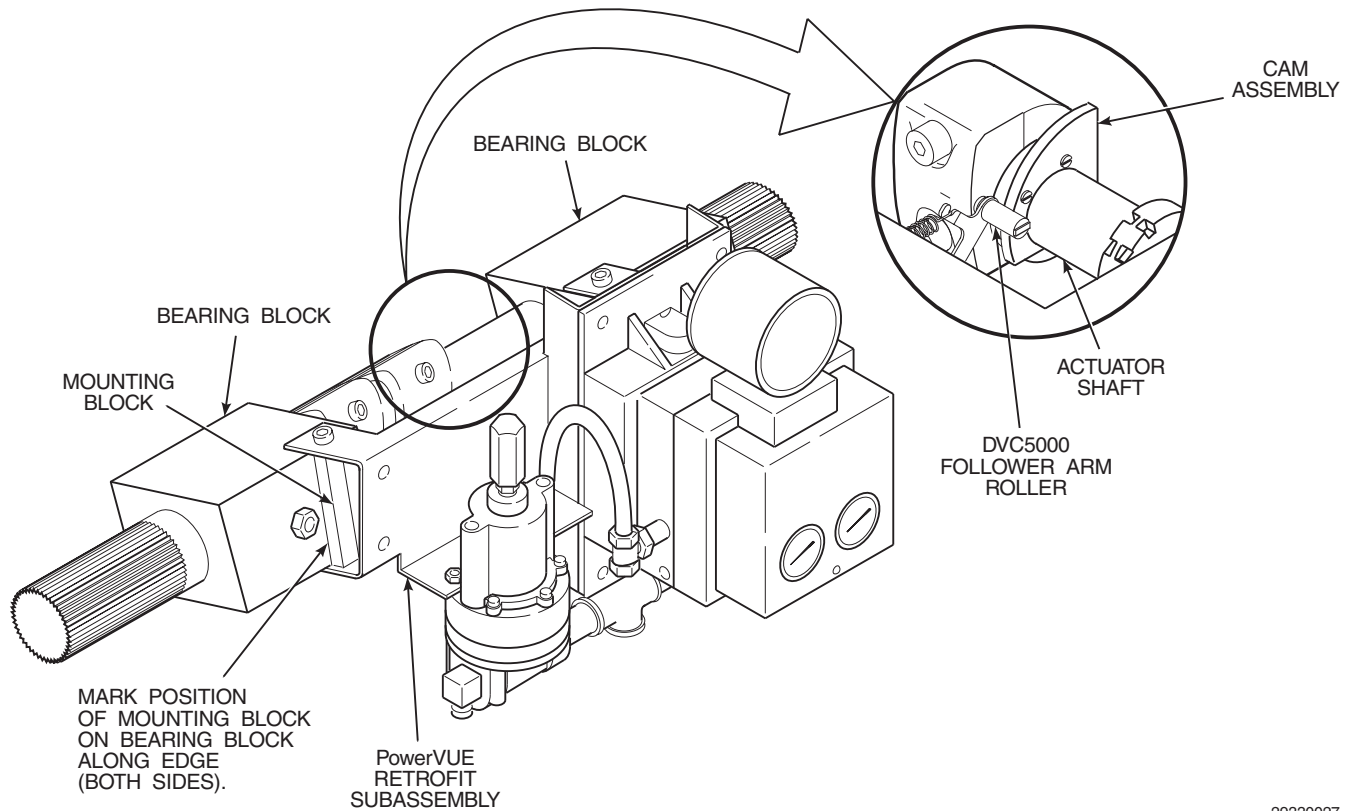

Figure A-5. PowerVUE Component Installation

6. Adjust cam assembly on actuator shaft so that the surface of the cam contacts DVC5000 follower arm roller squarely. Rotate the cam assembly so that the DVC5000 follower arm just retracts slightly. Tighten cam assembly to actuator shaft.

1. Install fitted air supply line (1, Figure A-6) to bottom T-fitting (2) between DVC5000 and reverse relay, and air manifold.
2. Install elbows (3) and fitted air lines (4) to top and bottom of positioner cylinder.

d. Install PowerVUE System Air Tubing.

NOTE

Prior to connecting supply air to the actuator, purge the air system to remove all moisture and debris.

Fitted air lines may be copper or stainless steel depending on specific kit order.

NOTE

Trip valve has air fittings pre-installed in port 4, port 5, and side as installation aid.

3. Install top fitted air line (4) to T-fitting in port 4 on top of trip valve. Install bottom fitted air line (4) to T-fitting in port 5 on bottom of trip valve.

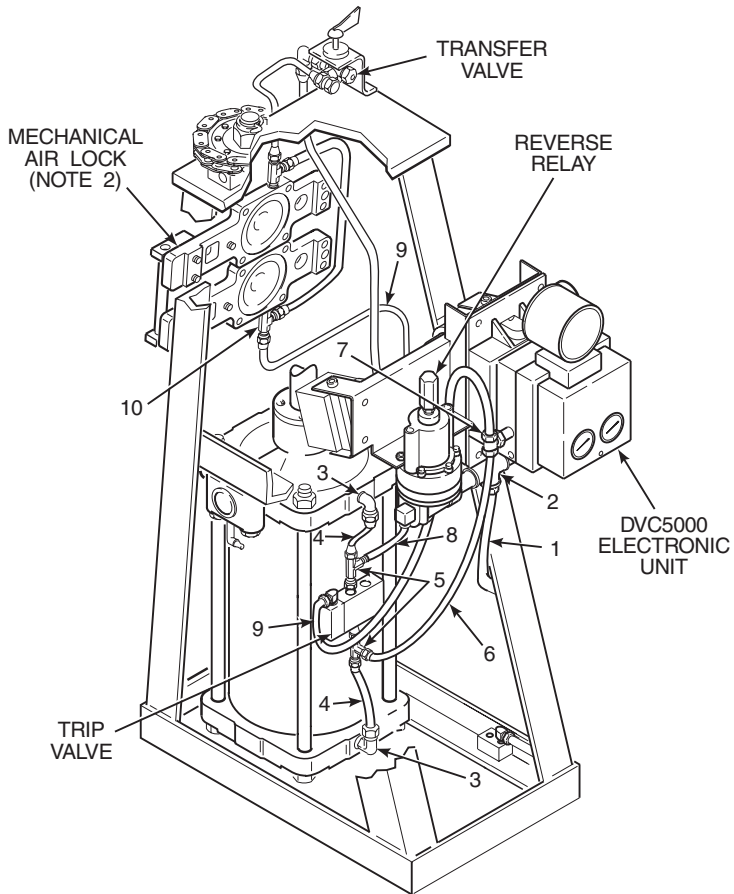

- NOTES: 1. ILLUSTRATION DEPICTS TUBING CONNECTION POINTS. ACTUAL ROUTING MAY APPEAR DIFFERENT.
2. ILLUSTRATION DEPICTS MECHANICAL AIR LOCK OPTION.
3. VALVE ASSEMBLY NUMBERS 1 THROUGH 5 REPRESENT ACTUAL NUMBERS VISIBLE ON THE ASSEMBLY.

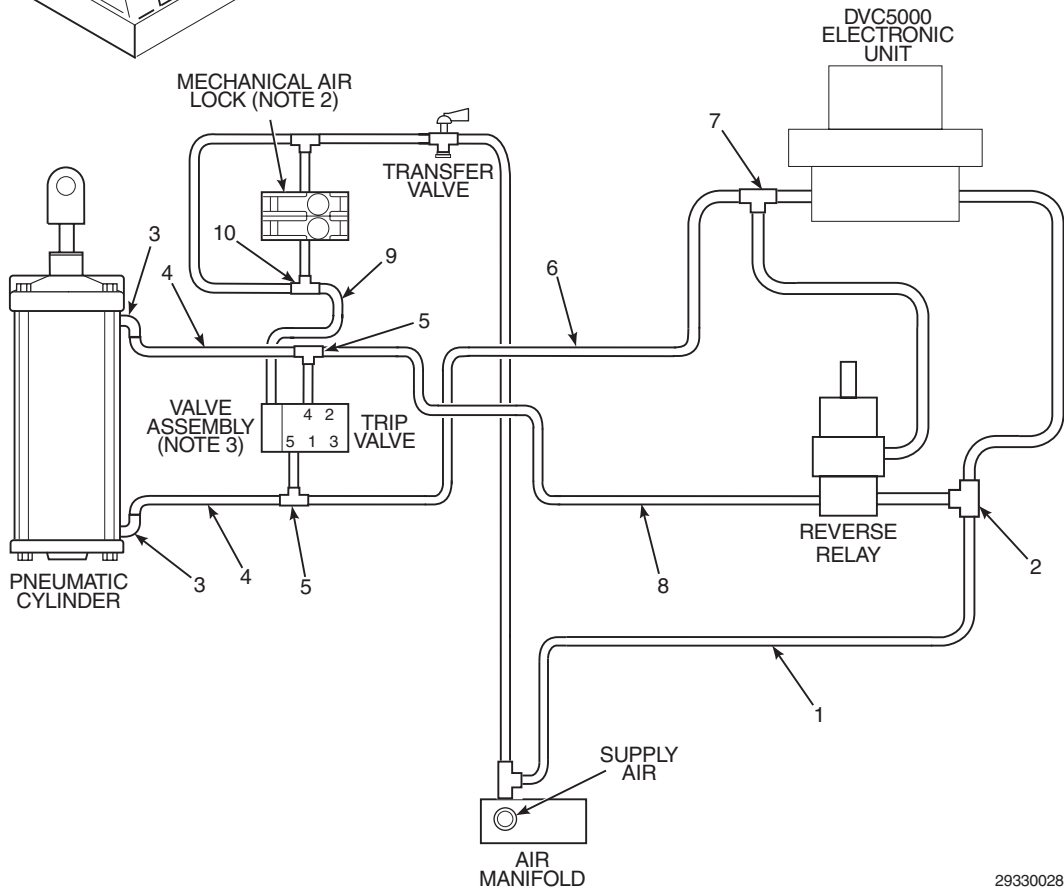

Figure A-6. Air Piping Diagram (with Mechanical Air Lock Option)

29330028

WARNING

Severe personal injury is possible. Do not attempt to cut flexible air tubing while supporting by hand. Place tubing on a suitable surface prior to cutting. Failure to take proper precautions can lead to blade slippage and serious injury.

NOTE

Ensure each section of flexible air line is of adequate length prior to cutting it from the roll of tubing.

4. Place flexible tubing on a suitable surface and cut adequate lengths of air line from the roll.
5. Install flexible tubing (6) from top T-fitting (7) between DVC5000 and reverse relay to T-fitting (5) in port 5 on bottom of trip valve.
6. Install flexible tubing (8) from fitting on output side of reverse relay to T-fitting (5) in port 4 on top of trip valve.

7. Install flexible tubing (9) from fitting on left side of trip valve to T-fitting (10) on bottom of mechanical air lock.
8. If the retrofit resulted in an open line leading from the transfer valve, remove the line and plug the open port on the transfer valve.

A-5. DVC5000 ELECTRONICS SETUP.

- a. **Introduction.** Initial setup of the DVC5000 has been performed at the factory. Refer to Sections 4 and 5 of FIELDVUE DVC5000 Series Digital Valve Controller Instruction Manual for any additional tuning that may be required for particular applications.

A-6. CALIBRATION.

- a. **Reverse Relay Calibration.** Refer to paragraph 4-1 to calibrate the reverse relay.
- b. **DVC5000 Calibration.** Refer to sections 4 and 6 of FIELDVUE DVC5000 Series Digital Valve Controller Instruction Manual to calibrate the DVC5000 electronic unit.

Appendix B
PowerVUE™
FAN/DAMPER ACTUATOR
TORQUE TYPE 8 x 14
for use with DVC6000 Series
DIGITAL VALVE CONTROLLER

RETROFIT KIT
INSTALLATION INSTRUCTIONS

Instruction Bulletin IB-102-208P Rev. 1.0

ROSEMOUNT® ANALYTICAL

FISHER-ROSEMOUNT™

TABLE OF CONTENTS

Section	Page
B. RETROFIT KIT INSTALLATION INSTRUCTIONS.....	B-1
B-1. Forward.....	B-1
B-2. Component Checklist.....	B-1
B-3. Overview.....	B-1
B-4. Mechanical Installation.....	B-2
B-5. DVC5000 Electronics Setup.....	B-7
B-6. Calibration.....	B-7

LIST OF ILLUSTRATIONS

Figure	Page
A-1	PowerVUE 8 x 14 Retrofit Kit..... iv
A-2	Retrofitted PowerVUE 8 x 14 Actuator..... B-1
A-3	8 x 14 Actuator (with Side Panels)..... B-2
A-4	Air Tubing and Positioner System (Pre-retrofit)..... B-3
A-5	Component Removal..... B-4
A-6	PowerVUE Component Installation..... B-5
A-7	Air Piping Diagram (with Mechanical Air Lock Option)..... B-6

Table B-1. Model Number Matrix

PowerVUE Retrofit Kit - ORDERING INFORMATION

Select complete model number from the Model Number Matrix.

PVD 468R	PowerVUE Drive⁽¹⁾			
	Code	Model		
	01	4 x 5		
	02	8 x 14 ⁽²⁾		
	Code	Digital Valve Controller		
	00	None ⁽³⁾		
	01	HART ⁽⁴⁾ DVC6000		
	02	Fieldbus ⁽⁵⁾ DVC5000, with Basic Control Suite		
	03	Fieldbus ⁽⁵⁾ DVC5000f, without Basic Control Suite		
	04	Other DVC Style Selected ⁽⁶⁾		
	Code	EPT		
	00	None		
	01	Digital EPT and 2 Limit Contacts (HART versions only) ⁽⁷⁾		
PVD 468R	02	02	01	EXAMPLE

NOTES:

- Performance and specifications may vary from the published specifications, depending on the age of the Hagan fan/damper actuator and the quality of the DVC5000/6000 installation. Setup and calibration is the responsibility of others. Faichild reversing relay is included with or without (selection of) DVC5000.
- Some rilling and tapping required. Existing covers may be modified in the field or a precut back cover can be selected (reference P/N 4851B28G01).
- Digital Valve Controller (DVC5000/6000) may be supplied by others, but no performance quarantees for accuracy or speeds of response are provided. Warranty for DVC5000/6000 will be the responsibility of the provider. Tubing is provided, but is not precut or preformed.
- Standard arrangement calls for Model DVC6020f-516G60, certified to FM as intrinsically safe, and Division 2. Other certifications are available. Advanced diagnostics provided.

- Standard arrangement calls for Model DVC5020f-216, certified to FM as intrinsically safe, and Division 2. Other certifications are available. Advanced diagnostics provided.
 - Designate other DVC5020/6020 model number as a note on order.
 - Utilizes Moore Industries Site Programmable HART Alarm.
 Default configuration:
 1 analog output representing actuator travel
 3 customer selectable position contacts
 1 contact for Field Device Failure
 Moore HART SPA may be configured in an intrinsically safe arrangement through an IS barrier.
- DVC5000/6000 Options:
- | | |
|------------------------------|-----------------------------|
| Flameproof cable gland: | ½" NPT (aluminum), EExd IIC |
| Cable entry adaptor (brass): | ½" NPT M20 x 1.5 ISO |
| | ½" NPT, PG 13.5 |

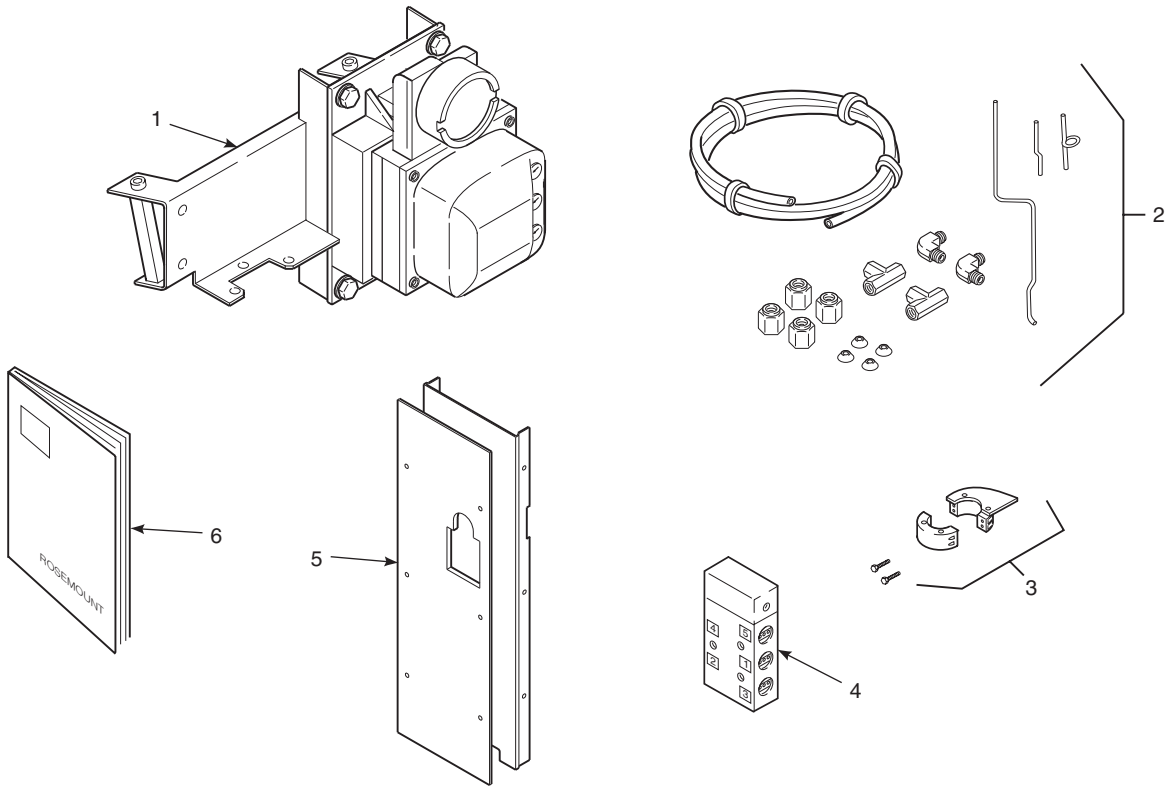

NOTE: PowerVUE RETROFIT SUBASSEMBLY INCLUDES DVC6000 ELECTRONIC UNIT, MOUNTING BRACKET, MOUNTING BLOCKS, HARDWARE, AND CONNECTING AIR FITTINGS.

- | | |
|--|--|
| 1. PowerVUE Retrofit Subassembly | 4. Trip Valve |
| 2. Flexible Air Line Tubing Roll, Fitted Air Lines, Fitting and Connectors | 5. Side Panels (With Cutouts) |
| 3. Cam Assembly | 6. PowerVUE 8x14 Actuator Instruction Bulletin with Retrofit Kit Installation Instructions |

35350008

Figure B-1. PowerVUE 8 x 14 Retrofit Kit

APPENDIX B RETROFIT KIT INSTALLATION INSTRUCTIONS

- B-1. FORWARD.** This appendix addresses how to replace an existing Hagan mechanical, pilot valve type, positioner system with a PowerVUE system. Removal, installation, and setup procedures are included. After completing this conversion, refer to the base sections of this instruction bulletin for future reference. The retrofit package includes a full instruction bulletin for the 8 x 14 PowerVUE Actuator. This instruction bulletin provides important information including startup, calibration, troubleshooting, and spare parts.

NOTE: ILLUSTRATED WITH
HANDWHEEL / MECHANICAL
AIR LOCK OPTION.

NOTE

The instruction bulletin for your existing power positioner (pre-retrofit) should be kept on file. Although Rosemount/Hagan continues to improve products and update instruction bulletins, the outdated instruction bulletin may still provide useful information.

- B-2. COMPONENT CHECKLIST.** A typical PowerVUE 8 x 14 Actuator Retrofit Kit should contain the items shown in Figure B-1.
- B-3. OVERVIEW.** The Rosemount PowerVUE 8 x 14 Actuator Retrofit Kit is designed for installation on the Hagan 8 x 14 Torque Type Power Positioner. The retrofit allows a 4-20 mA or fieldbus input signal sent by a user's process controller, to be received by the DVC6000 electronic unit. The DVC6000 electronic unit converts the input signal to a pneumatic output pressure which is sent to the top or bottom of the pneumatic cylinder, positioning and locking the piston in place. A retrofitted PowerVUE 8 x 14 Actuator is shown in Figure B-1.

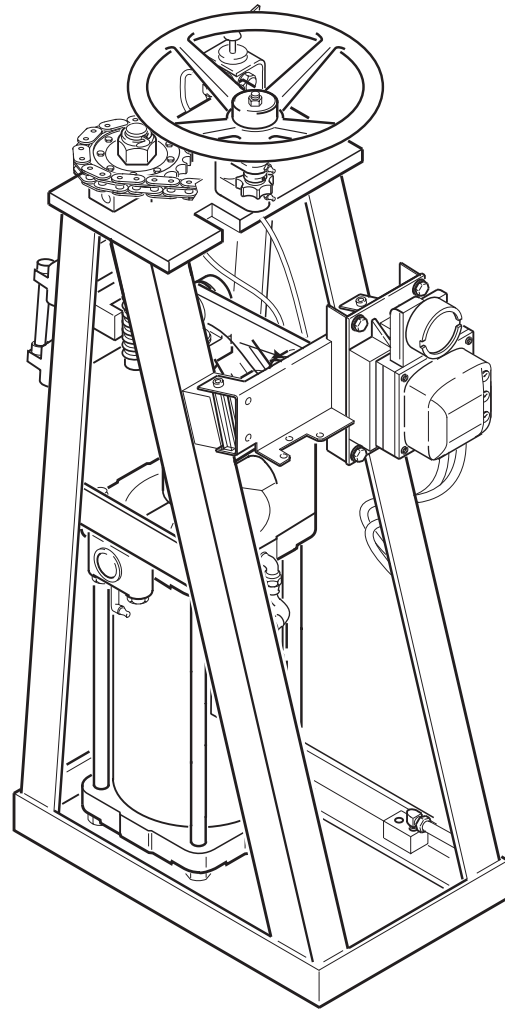

35350009

Figure B-1. Retrofitted PowerVUE 8 x 14 Actuator

B-4. MECHANICAL INSTALLATION.

WARNING

Before performing any retrofit actions on the actuator, isolate the actuator from all electrical and pneumatic systems. Severe injury or death may result from the large torque produced by the actuator.

a. Remove Actuator from Service.

NOTE

It is recommended that the actuator be decommissioned and moved prior to retrofitting the unit. Decommissioning and moving the unit will allow the removal of all covers, making component removal and installation much easier.

It is possible to complete the retrofit with the actuator in place. If the unit is to remain in place, use the “manual mode” of operation and remove all covers with the exception of the operating lever side cover.

1. Remove the actuator from service. Isolate the actuator from the air supply by disconnecting the air supply or closing the supply air shutoff valve (as applicable to the system). Isolate electrical power and electronic signals to the actuator.

2. Open the drain cock on the air filter to exhaust the air supply from the actuator.
3. If the unit is equipped with a transfer valve, place the transfer valve in the manual position (Figure B-2).
4. If leaving the unit in place during the retrofit, remove the side panels with the exception of the panel on the side of the operating lever.

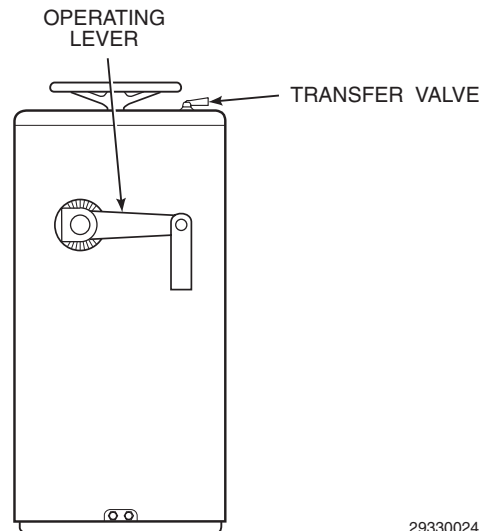

29330024

**Figure B-2. 8 x 14 Actuator
(with Side Panels)**

b. Remove Pneumatic Positioning Components.

NOTE

The limit switch assembly may be removed or reused. If removed, leave the outer cam saddle to serve as a thrust bearing.

The limit stop is not affected by the retrofit.

The heater/thermostat option is not affected by the retrofit.

The air lock option is not affected by the retrofit.

1. Disconnect and remove tubing from the diaphragm/spring assembly, pilot valve, and pilot valve manifold, Figure B-3.

2. Remove tubing and elbow fittings from the pneumatic cylinder.
3. Turn the handwheel counterclockwise to expose the pilot valve stem.
4. Unscrew the valve stem and separate the stem from the connecting link.
5. Remove cam assembly (1, Figure B-4) from shaft (2).
6. Remove the diaphragm/spring assembly (3) from the frame.
7. Remove the pilot valve/pilot valve manifold (4) from the frame.

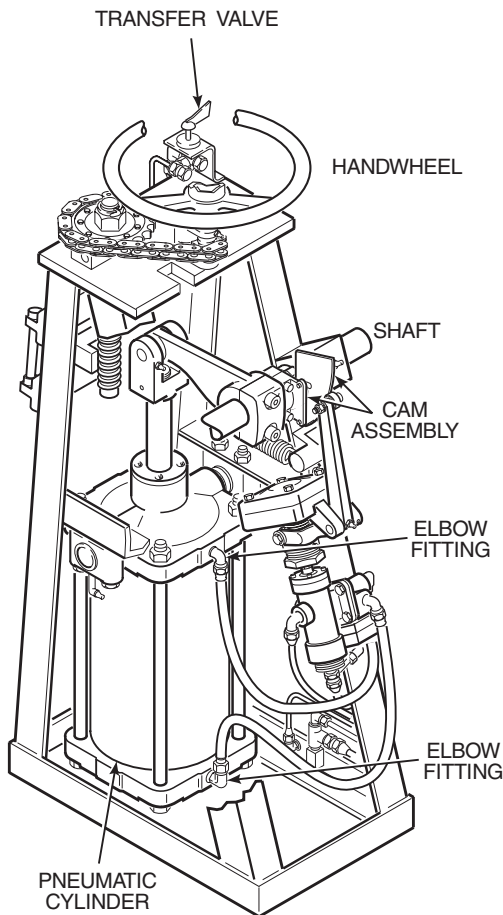

NOTE: ILLUSTRATED WITH HANDWHEEL/
MECHANICAL AIR LOCK OPTION.

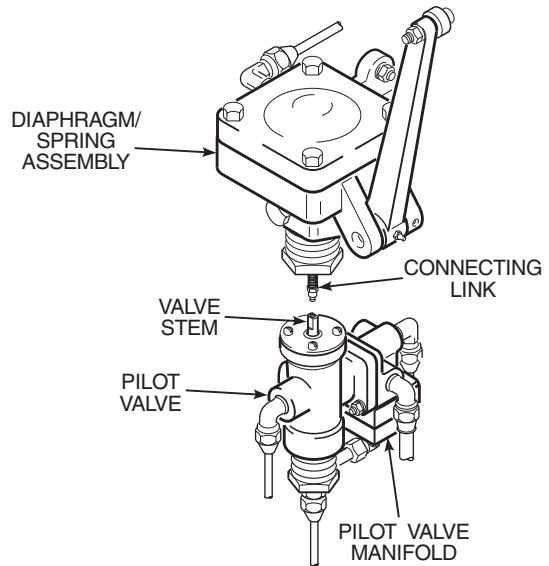

29330025

Figure B-3. Air Tubing and Positioner System (Pre-retrofit)

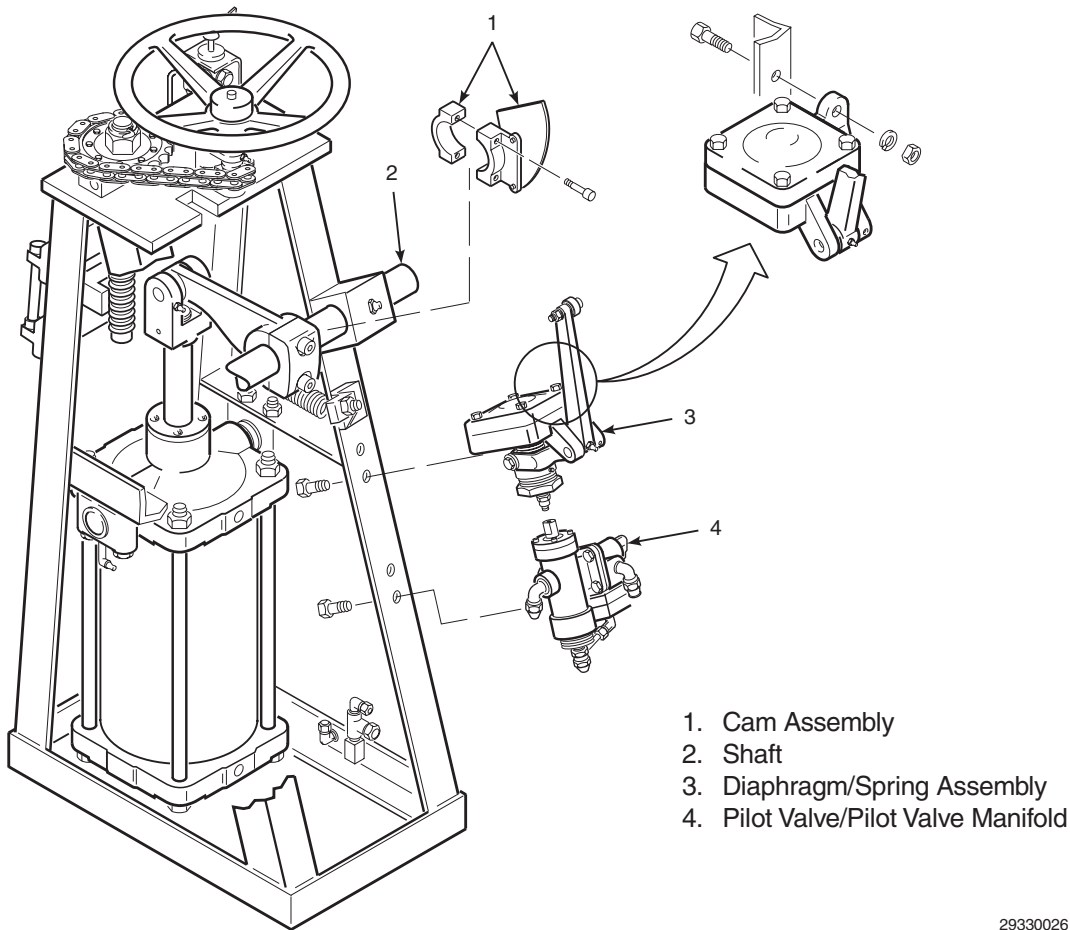

1. Cam Assembly
2. Shaft
3. Diaphragm/Spring Assembly
4. Pilot Valve/Pilot Valve Manifold

29330026

Figure B-4. Component Removal

c. Install PowerVUE Components.

NOTE

Before installing any PowerVUE retrofit components on the unit, ensure pneumatic cylinder piston is completely down.

1. Ensure pneumatic cylinder piston is completely down.
2. Install cam assembly to shaft, Figure B-5. Leave screws loose so cam rotates on shaft for later adjustment.
3. Hold up PowerVUE retrofit subassembly to bearing blocks and mark position of mounting blocks, Figure B-5.

CAUTION

Ensure weld splash does not damage actuator shaft, grease fittings, mounting hardware holes, or any other actuator components.

4. Remove mounting blocks from PowerVUE retrofit subassembly and weld to bearing blocks in marked positions. Ensure weld splash does not damage actuator components.
5. Install PowerVUE retrofit subassembly to mounting blocks with two allen screws provided.

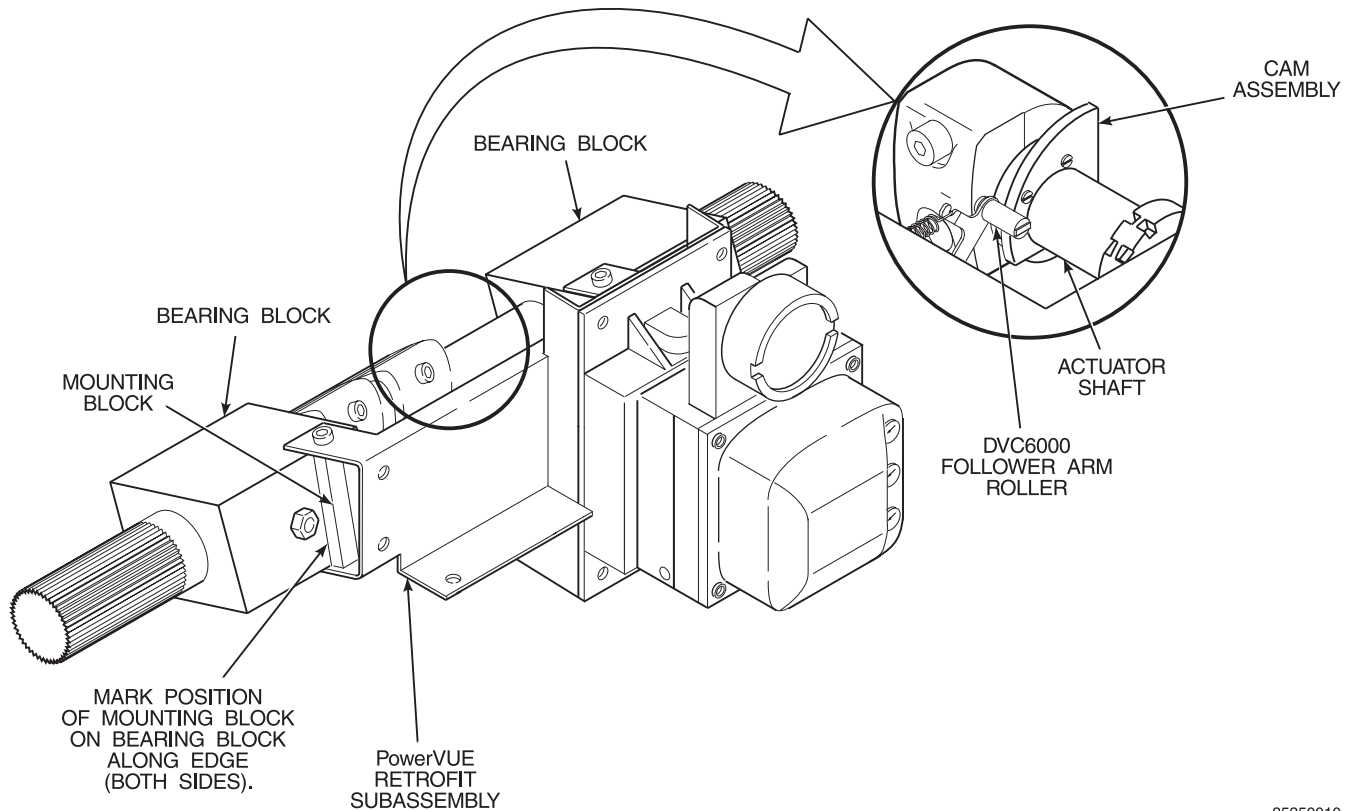

35350010

Figure B-5. PowerVUE Component Installation

6. Adjust cam assembly on actuator shaft so that the surface of the cam contacts DVC6000 follower arm roller squarely. Rotate the cam assembly so that the DVC6000 follower arm just retracts slightly. Tighten cam assembly to actuator shaft.

1. Install air supply line (1, Figure B-6) to T-fitting (2). Connect air supply line between DVC6000 and air manifold.
2. Install elbows (3) and fitted air lines (4) to top and bottom of pneumatic cylinder.

d. Install PowerVUE System Air Tubing.

NOTE

Prior to connecting supply air to the actuator, purge the air system to remove all moisture and debris.

Fitted air lines may be copper or stainless steel depending on specific kit order.

NOTE

Trip valve has air fittings pre-installed in port 4, port 5, and side as installation aid.

3. Install top fitted air line (4) to T-fitting in port 4 on top of trip valve. Install bottom fitted air line (4) to T-fitting in port 5 on bottom of trip valve.

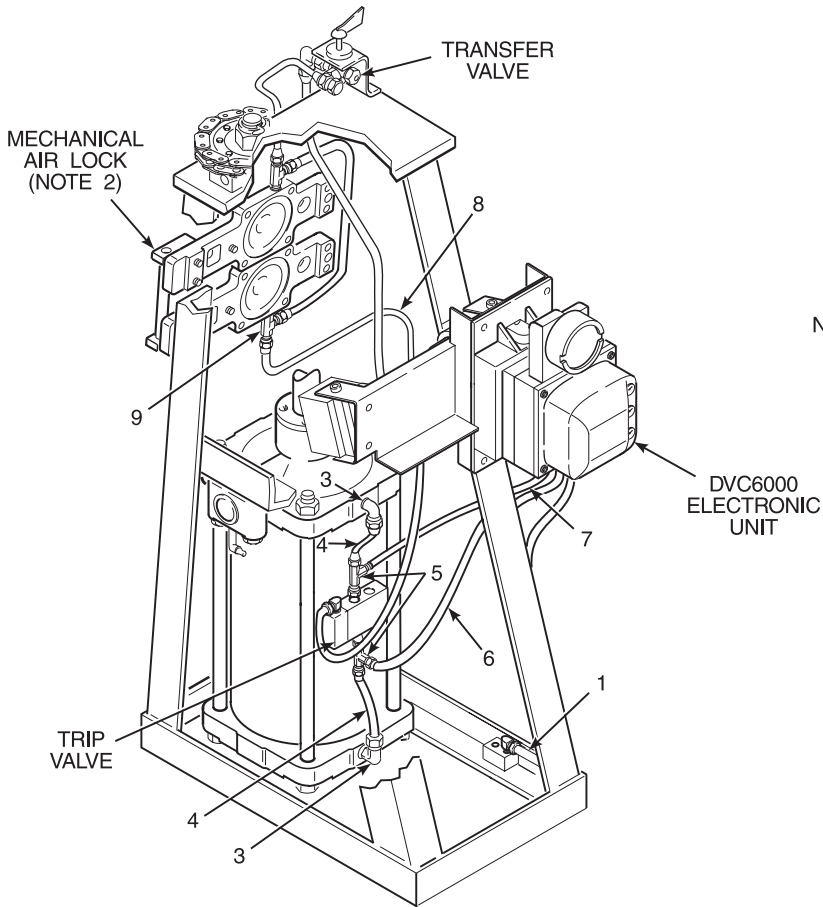

- NOTES: 1. ILLUSTRATION DEPICTS TUBING CONNECTION POINTS. ACTUAL ROUTING MAY APPEAR DIFFERENT.
2. ILLUSTRATION DEPICTS MECHANICAL AIR LOCK OPTION.
3. VALVE ASSEMBLY NUMBERS 1 THROUGH 5 REPRESENT ACTUAL NUMBERS VISIBLE ON THE ASSEMBLY.

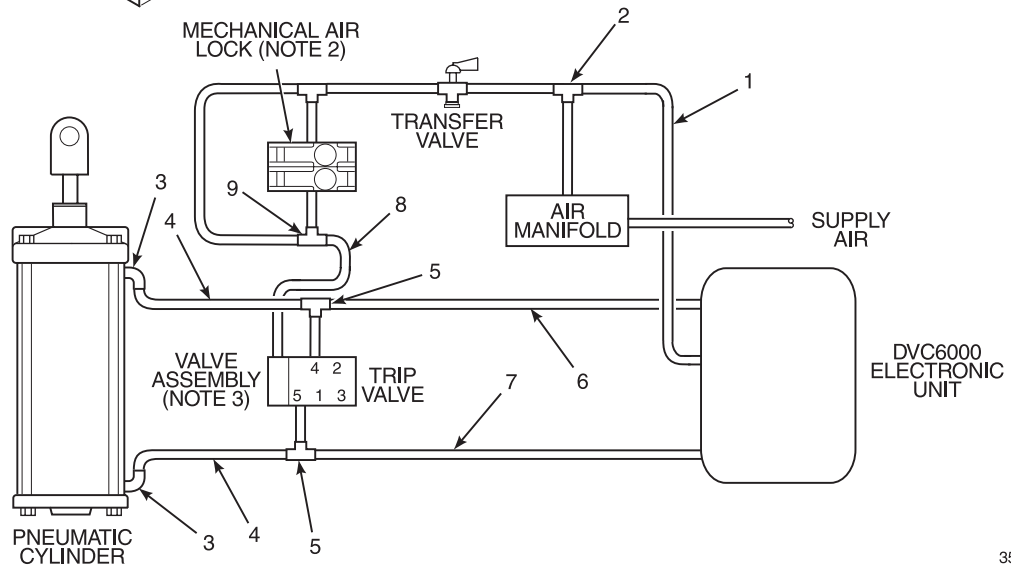

35350011

Figure B-6. Air Piping Diagram (with Mechanical Air Lock Option)

WARNING

Severe personal injury is possible. Do not attempt to cut flexible air tubing while supporting by hand. Place tubing on a suitable surface prior to cutting. Failure to take proper precautions can lead to blade slippage and serious injury.

NOTE

Ensure each section of flexible air line is of adequate length prior to cutting it from the roll of tubing.

4. Place flexible tubing on a suitable surface and cut adequate lengths of air line from the roll.
 5. Install flexible tubing (6) from top T-fitting (5) to port A (top port) of DVC6000.
 6. Install flexible tubing (7) from T-fitting (5) on top of trip valve to port B (bottom port) of DVC6000.
 7. Install flexible tubing (8) from fitting on left side of trip valve to T-fitting (9) on bottom of mechanical air lock.
 8. If the retrofit resulted in an open line leading from the transfer valve, remove the line and plug the open port on the transfer valve.
- B-5. DVC6000 ELECTRONICS SETUP.** Initial setup of the DVC6000 has been performed at the factory. Refer to Sections 4 and 5 of FIELDVUE DVC6000 Series Digital Valve Controller Instruction Manual for any additional tuning that may be required for particular applications.
- B-6. CALIBRATION.** Refer to Sections 4 and 6 of FIELDVUE DVC6000 Series Digital Valve Controller Instruction Manual to calibrate the DVC6000 electronic unit.

WARRANTY

Goods and part(s) (excluding consumables) manufactured by Seller are warranted to be free from defects in workmanship and material under normal use and service for a period of twelve (12) months from the date of shipment by Seller. Consumables, glass electrodes, membranes, liquid junctions, electrolyte, o-rings, etc., are warranted to be free from defects in workmanship and material under normal use and service for a period of ninety (90) days from date of shipment by Seller. Goods, part(s) and consumables proven by Seller to be defective in workmanship and/or material shall be replaced or repaired, free of charge, F.O.B. Seller's factory provided that the goods, part(s) or consumables are returned to Seller's designated factory, transportation charges prepaid, within the twelve (12) month period of warranty in the case of goods and part(s), and in the case of consumables, within the ninety (90) day period of warranty. This warranty shall be in effect for replacement or repaired goods, part(s) and the remaining portion of the ninety (90) day warranty in the case of consumables. A defect in goods, part(s) and consumables of the commercial unit shall not operate to condemn such commercial unit when such goods, part(s) and consumables are capable of being renewed, repaired or replaced.

The Seller shall not be liable to the Buyer, or to any other person, for the loss or damage directly or indirectly, arising from the use of the equipment or goods, from breach of any warranty, or from any other cause. All other warranties, expressed or implied are hereby excluded.

IN CONSIDERATION OF THE HEREIN STATED PURCHASE PRICE OF THE GOODS, SELLER GRANTS ONLY THE ABOVE STATED EXPRESS WARRANTY. NO OTHER WARRANTIES ARE GRANTED INCLUDING, BUT NOT LIMITED TO, EXPRESS AND IMPLIED WARRANTIES OR MERCHANTABILITY AND FITNESS FOR A PARTICULAR PURPOSE.

Limitations of Remedy. SELLER SHALL NOT BE LIABLE FOR DAMAGES CAUSED BY DELAY IN PERFORMANCE. THE SOLE AND EXCLUSIVE REMEDY FOR BREACH OF WARRANTY SHALL BE LIMITED TO REPAIR OR REPLACEMENT UNDER THE STANDARD WARRANTY CLAUSE. IN NO CASE, REGARDLESS OF THE FORM OF THE CAUSE OF ACTION, SHALL SELLER'S LIABILITY EXCEED THE PRICE TO BUYER OF THE SPECIFIC GOODS MANUFACTURED BY SELLER GIVING RISE TO THE CAUSE OF ACTION. BUYER AGREES THAT IN NO EVENT SHALL SELLER'S LIABILITY EXTEND TO INCLUDE INCIDENTAL OR CONSEQUENTIAL DAMAGES. CONSEQUENTIAL DAMAGES SHALL INCLUDE, BUT ARE NOT LIMITED TO, LOSS OF ANTICIPATED PROFITS, LOSS OF USE, LOSS OF REVENUE, COST OF CAPITAL AND DAMAGE OR LOSS OF OTHER PROPERTY OR EQUIPMENT. IN NO EVENT SHALL SELLER BE OBLIGATED TO INDEMNIFY BUYER IN ANY MANNER NOR SHALL SELLER BE LIABLE FOR PROPERTY DAMAGE AND/OR THIRD PARTY CLAIMS COVERED BY UMBRELLA INSURANCE AND/OR INDEMNITY COVERAGE PROVIDED TO BUYER, ITS ASSIGNS, AND EACH SUCCESSOR INTEREST TO THE GOODS PROVIDED HEREUNDER.

Force Majeure. Seller shall not be liable for failure to perform due to labor strikes or acts beyond Seller's direct control.

Instruction Manual

IB-102-208P Rev. 1.1

November 2001

PowerVUE™ Fan/Damper Actuator

PowerVUE™	
Part no.	_____
Serial no.	_____
Order no.	_____

Emerson Process Management

Rosemount Analytical Inc. Process Analytic Division

1201 N. Main St.
Orrville, OH 44667-0901
T (330) 682-9010
F (330) 684-4434
E gas.csc@emersonprocess.com

Fisher-Rosemount GmbH & Co.

Industriestrasse 1
63594 Hasselroth
Germany
T 49-6055-884 0
F 49-6055-884209

ASIA - PACIFIC

Fisher-Rosemount Singapore Private Ltd.

1 Pandan Crescent
Singapore 128461
Republic of Singapore
T 65-777-8211
F 65-777-0947

<http://www.processanalytic.com>

EUROPE, MIDDLE EAST, AFRICA

Fisher-Rosemount Ltd.

Heath Place
Bognor Regis
West Sussex PO22 9SH
England
T 44-1243-863121
F 44-1243-845354

LATIN AMERICA

Fisher - Rosemount

Av. das Americas
3333 sala 1004
Rio de Janeiro, RJ
Brazil 22631-003
T 55-21-2431-1882