

# Operating Instructions

Capacitive level switch

## VEGAPOINT 31

Transistor (NPN/PNP)



Document ID: 62097



**VEGA**

# Contents

<b>1</b>	<b>About this document</b>	<b>4</b>
1.1	Function	4
1.2	Target group	4
1.3	Symbols used	4
<b>2</b>	<b>For your safety</b>	<b>5</b>
2.1	Authorised personnel	5
2.2	Appropriate use	5
2.3	Warning about incorrect use	5
2.4	General safety instructions	5
2.5	Installation and operation in the USA and Canada	5
2.6	Safety instructions for Ex areas	6
<b>3</b>	<b>Product description</b>	<b>7</b>
3.1	Configuration	7
3.2	Principle of operation	8
3.3	Adjustment	9
3.4	Packaging, transport and storage	10
3.5	Accessories	11
<b>4</b>	<b>Mounting</b>	<b>12</b>
4.1	General instructions	12
4.2	Mounting instructions	13
<b>5</b>	<b>Connecting to power supply</b>	<b>14</b>
5.1	Preparing the connection	14
5.2	Connecting	15
5.3	Wiring plan	18
5.4	Switch-on phase	18
<b>6</b>	<b>Access protection</b>	<b>19</b>
6.1	Bluetooth radio interface	19
6.2	Protection of the parameterization	19
6.3	Storing the codes in myVEGA	20
<b>7</b>	<b>Setup</b>	<b>21</b>
7.1	Indication of the switching status	21
7.2	Function table	21
7.3	Menu overview	21
7.4	Parameter adjustment	23
<b>8</b>	<b>Setup with smartphone/tablet (Bluetooth)</b>	<b>31</b>
8.1	Preparations	31
8.2	Connecting	31
8.3	Sensor parameter adjustment	32
<b>9</b>	<b>Setup with PC/notebook (Bluetooth)</b>	<b>33</b>
9.1	Preparations	33
9.2	Connecting	33
9.3	Sensor parameter adjustment	34
<b>10</b>	<b>Diagnostics and servicing</b>	<b>35</b>
10.1	Maintenance	35

10.2	Rectify faults.....	35
10.3	Diagnosis, fault messages .....	36
10.4	Status messages according to NE 107 .....	37
10.5	Software update .....	39
10.6	How to proceed if a repair is necessary.....	39
<b>11</b>	<b>Dismount.....</b>	<b>40</b>
11.1	Dismounting steps.....	40
11.2	Disposal .....	40
<b>12</b>	<b>Certificates and approvals.....</b>	<b>41</b>
12.1	Radio licenses.....	41
12.2	Food and pharmaceutical certificates.....	41
12.3	Conformity.....	41
12.4	Environment management system .....	41
<b>13</b>	<b>Supplement .....</b>	<b>42</b>
13.1	Technical data .....	42
13.2	Dimensions .....	45
13.3	Industrial property rights.....	47
13.4	Licensing information for open source software .....	47
13.5	Trademark .....	47

# 1 About this document

## 1.1 Function

This instruction provides all the information you need for mounting, connection and setup as well as important instructions for maintenance, fault rectification, the exchange of parts and the safety of the user. Please read this information before putting the instrument into operation and keep this manual accessible in the immediate vicinity of the device.

## 1.2 Target group

This operating instructions manual is directed to trained personnel. The contents of this manual must be made available to the qualified personnel and implemented.

## 1.3 Symbols used



### Document ID

This symbol on the front page of this instruction refers to the Document ID. By entering the Document ID on [www.vega.com](http://www.vega.com) you will reach the document download.



**Information, note, tip:** This symbol indicates helpful additional information and tips for successful work.



**Note:** This symbol indicates notes to prevent failures, malfunctions, damage to devices or plants.



**Caution:** Non-observance of the information marked with this symbol may result in personal injury.



**Warning:** Non-observance of the information marked with this symbol may result in serious or fatal personal injury.



**Danger:** Non-observance of the information marked with this symbol results in serious or fatal personal injury.



### Ex applications

This symbol indicates special instructions for Ex applications.



### List

The dot set in front indicates a list with no implied sequence.



### Sequence of actions

Numbers set in front indicate successive steps in a procedure.



### Disposal

This symbol indicates special instructions for disposal.

## 2 For your safety

### 2.1 Authorised personnel

All operations described in this documentation must be carried out only by trained, qualified personnel authorised by the plant operator.

During work on and with the device, the required personal protective equipment must always be worn.

### 2.2 Appropriate use

The VEGAPOINT 31 is a sensor for point level detection.

You can find detailed information about the area of application in chapter " *Product description*".

Operational reliability is ensured only if the instrument is properly used according to the specifications in the operating instructions manual as well as possible supplementary instructions.

### 2.3 Warning about incorrect use

Inappropriate or incorrect use of this product can give rise to application-specific hazards, e.g. vessel overfill through incorrect mounting or adjustment. Damage to property and persons or environmental contamination can result. Also, the protective characteristics of the instrument can be impaired.

### 2.4 General safety instructions

This is a state-of-the-art instrument complying with all prevailing regulations and directives. The instrument must only be operated in a technically flawless and reliable condition. The operator is responsible for the trouble-free operation of the instrument. When measuring aggressive or corrosive media that can cause a dangerous situation if the instrument malfunctions, the operator has to implement suitable measures to make sure the instrument is functioning properly.

The safety instructions in this operating instructions manual, the national installation standards as well as the valid safety regulations and accident prevention rules must be observed by the user.

For safety and warranty reasons, any invasive work on the device beyond that described in the operating instructions manual may be carried out only by personnel authorised by the manufacturer. Arbitrary conversions or modifications are explicitly forbidden. For safety reasons, only the accessory specified by the manufacturer must be used.

To avoid any danger, the safety approval markings and safety tips on the device must also be observed.

### 2.5 Installation and operation in the USA and Canada

This information is only valid for USA and Canada. Hence the following text is only available in the English language.

Installations in the US shall comply with the relevant requirements of the National Electrical Code (ANSI/NFPA 70).

Installations in Canada shall comply with the relevant requirements of the Canadian Electrical Code

A Class 2 power supply unit has to be used for the installation in the USA and Canada.

## **2.6 Safety instructions for Ex areas**

For applications in explosion-proof areas (Ex), only devices with corresponding Ex approval may be used. Observe the Ex-specific safety instructions. These are an integral part of the operating instructions and are enclosed with every device with Ex approval.

### 3 Product description

#### 3.1 Configuration

**Scope of delivery**

The scope of delivery encompasses:

- VEGAPOINT 31 point level switch
- Information sheet " *Documents and software*" with:
  - Instrument serial number
  - QR code with link for direct scanning
- Information sheet " *PINs and Codes*" (with Bluetooth versions) with:
  - Bluetooth access code



**Information:**

Optional instrument features are also described in this operating instructions manual. The respective scope of delivery results from the order specification.

**Scope of this operating instructions**

This operating instructions manual applies to the following instrument versions:

- Hardware version from 1.0.1
- Software version from 1.4.4

**Constituent parts**

The VEGAPOINT 31 consists of the components:

- Housing with integrated electronics
- Process fitting
- Plug

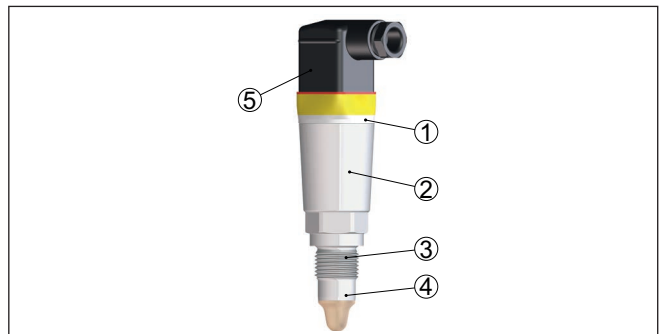

Fig. 1: VEGAPOINT 31

- 1 LED illuminated ring
- 2 Instrument housing
- 3 Process fitting
- 4 Sensor
- 5 Plug connection

**Type label**

You will find the type plate on the sensor housing.

The type label contains the most important data for identification and use of the instrument.

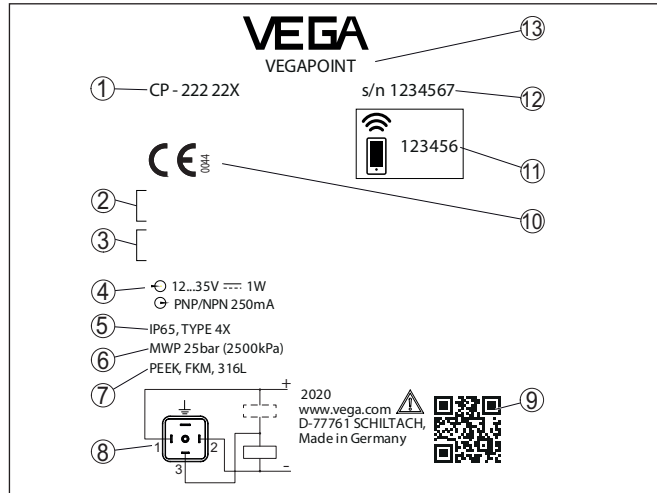

Fig. 2: Layout of the type label (example)

- 1 Order number
- 2 Approvals (option)
- 3 Warning instructions
- 4 Voltage supply and signal output
- 5 Protection rating
- 6 Permissible process pressure
- 7 Material, wetted parts
- 8 Connection diagram
- 9 QR code for device documentation
- 10 Conformities and approvals (optional)
- 11 Bluetooth access code
- 12 Serial number
- 13 Product name

## Documents and software

Move to "[www.vega.com](http://www.vega.com)" and enter in the search field the serial number of your instrument.

There you can find the following information about the instrument:

- Order data
- Documentation
- Software

Alternatively, you can find all via your smartphone:

- Scan the QR-code on the type label of the device or
- Enter serial number manually in the VEGA Tools app (available free of charge in the respective stores)

## 3.2 Principle of operation

The VEGAPOINT 31 is a capacitive point level sensor for point level detection

## Application area

It is designed for industrial use in all areas of process technology and can be used in light-weight, fine bulk solids.

Typical applications are overfill and dry run protection. Due to its simple and robust measuring system, the VEGAPOINT 31 can be used in almost all powdery bulk solids.

#### **Function monitoring**

The electronics module of VEGAPOINT 31 continuously monitors the following criteria via frequency generation:

- Failure of the signal generation
- Line break to the sensor element

If a malfunction is detected or in case of voltage supply, the electronics takes on a defined switching status, i.e. the output is open (safe state).

#### **Functional principle**

An alternating electric field is generated at the tip of the measuring electrode. If the sensor is covered with medium, the resonance frequency changes. This change is detected by the electronics and converted into a switching command.

Buildup is ignored to a certain degree and therefore has no influence on the measurement.

### **3.3 Adjustment**

#### **Local adjustment**

The switching status of VEGAPOINT 31 can be checked from outside (LED illuminated ring).

#### **Wireless adjustment**

The optionally integrated Bluetooth module enables in addition a wireless adjustment of VEGAPOINT 31.

This is done via standard operating devices:

- Smartphone/tablet (iOS or Android operating system)
- PC/notebook with Bluetooth LE or Bluetooth USB adapter (Windows operating system)

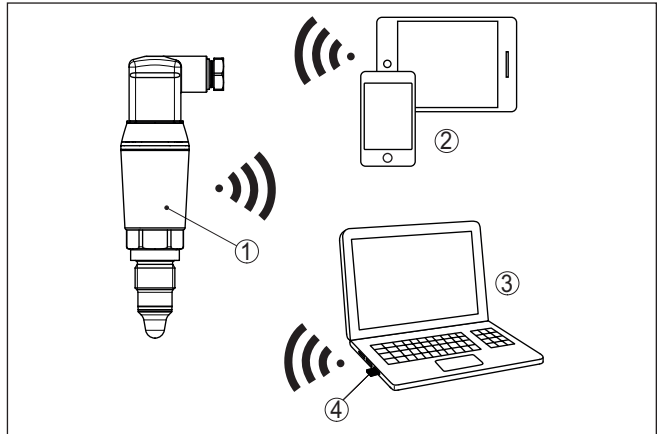

Fig. 3: Wireless connection to standard adjustment devices with integrated Bluetooth LE or alternatively Bluetooth USB adapter.

- 1 Sensor
- 2 Smartphone/Tablet
- 3 PC/Notebook
- 4 Bluetooth USB adapter

### 3.4 Packaging, transport and storage

#### Packaging

Your instrument was protected by packaging during transport. Its capacity to handle normal loads during transport is assured by a test based on ISO 4180.

The packaging consists of environment-friendly, recyclable cardboard. For special versions, PE foam or PE foil is also used. Dispose of the packaging material via specialised recycling companies.

#### Transport

Transport must be carried out in due consideration of the notes on the transport packaging. Nonobservance of these instructions can cause damage to the device.

#### Transport inspection

The delivery must be checked for completeness and possible transit damage immediately at receipt. Ascertained transit damage or concealed defects must be appropriately dealt with.

#### Storage

Up to the time of installation, the packages must be left closed and stored according to the orientation and storage markings on the outside.

Unless otherwise indicated, the packages must be stored only under the following conditions:

- Not in the open
- Dry and dust free
- Not exposed to corrosive media
- Protected against solar radiation
- Avoiding mechanical shock and vibration

**Storage and transport temperature**

- Storage and transport temperature see chapter "*Supplement - Technical data - Ambient conditions*"
- Relative moisture 20 ... 85 %

**3.5 Accessories**

The instructions for the listed accessories can be found in the download area on our homepage.

**Threaded and hygienic socket**

Various threaded and hygienic sockets are available for devices with threaded version.

You can find further information in chapter "*Technical Data*".

## 4 Mounting

### 4.1 General instructions

#### Ambient conditions

The instrument is suitable for standard and extended ambient conditions acc. to DIN/EN/IEC/ANSI/ISA/UL/CSA 61010-1. It can be used indoors as well as outdoors.

#### Process conditions



#### Note:

For safety reasons, the instrument must only be operated within the permissible process conditions. You can find detailed information on the process conditions in chapter " *Technical data* " of the operating instructions or on the type label.

Hence make sure before mounting that all parts of the instrument exposed to the process are suitable for the existing process conditions.

These are mainly:

- Active measuring component
- Process fitting
- Process seal

Process conditions in particular are:

- Process pressure
- Process temperature
- Chemical properties of the medium
- Abrasion and mechanical influences

#### Switching point

The VEGAPOINT 31 can be mounted in any position. The instrument must be mounted in such a way that the sensor is at the height of the requested switching point.

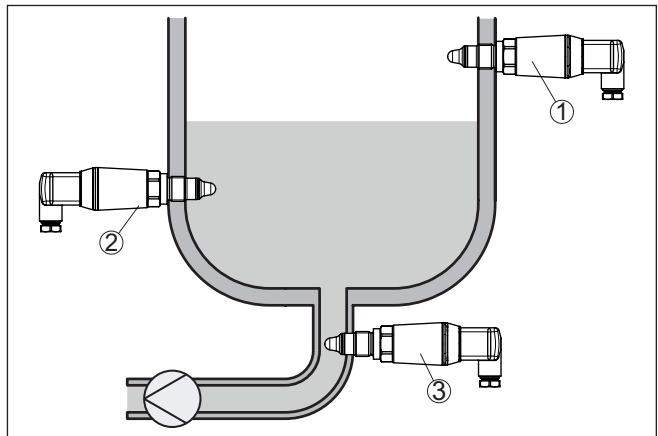

Fig. 4: Installation examples

- 1 Upper level detection (max.) as overflow protection
- 2 Lower level detection (min.) as dry run protection
- 3 Dry run protection (min.) for a pump

Note that the switching point varies depending on the type of medium and the mounting position of the sensor.

### Protection against moisture

Protect your instrument against moisture ingress through the following measures:

- Use a suitable connection cable (see chapter " *Connecting to power supply*")
- Tighten the cable gland or plug connector
- Lead the connection cable downward in front of the cable entry or plug connector

This applies mainly to outdoor installations, in areas where high humidity is expected (e.g. through cleaning processes) and on cooled or heated vessels.

### Handling

The level switch is a measuring device for stationary screw mounting and must be treated accordingly. Damage to the measuring tip will destroy the instrument.

Use the hexagon above the thread for screwing in.

After mounting, make sure that the process fitting is screwed in correctly and thus securely seals even at maximum process pressure.

### Inflowing medium

## 4.2 Mounting instructions

If VEGAPOINT 31 is mounted in the filling stream, unwanted false measurement signals can be generated. For this reason, mount VEGAPOINT 31 at a position in the vessel where no disturbances, e.g. from filling openings, agitators, etc., can occur.

## 5 Connecting to power supply

### 5.1 Preparing the connection

#### Safety instructions

Always keep in mind the following safety instructions:

- Carry out electrical connection by trained, qualified personnel authorised by the plant operator
- If overvoltage surges are expected, overvoltage arresters should be installed



#### Warning:

Only connect or disconnect in de-energized state.

#### Voltage supply

The data for power supply are specified in chapter " *Technical data*".



#### Note:

Power the instrument via an energy-limited circuit (power max. 100 W) acc. to IEC 61010-1, e.g.

- Class 2 power supply unit (acc. to UL1310)
- SELV power supply unit (safety extra-low voltage) with suitable internal or external limitation of the output current

Keep in mind the following additional factors that influence the operating voltage:

- Lower output voltage of the power supply unit under nominal load
- Influence of additional instruments in the circuit (see load values in chapter " *Technical data*")

#### Connection cable

Use cable with round cross section. Depending on the plug connection, you have to select the outer diameter of the cable respectively so that the seal effect of the cable gland is ensured.

The instrument is connected with standard four-wire cable. If electromagnetic interference is expected which is above the test values of EN 61326-1 for industrial areas, shielded cable should be used.

- Valve plug ISO 4400,  $\varnothing$  4.5 ... 7 mm
- Valve plug ISO 4400 with IDC crimping technology,  $\varnothing$  5.5 ... 8 mm
- Valve plug ISO 4400 with hinged cover,  $\varnothing$  4,5 ... 7 mm

## 5.2 Connecting

### Instrument versions

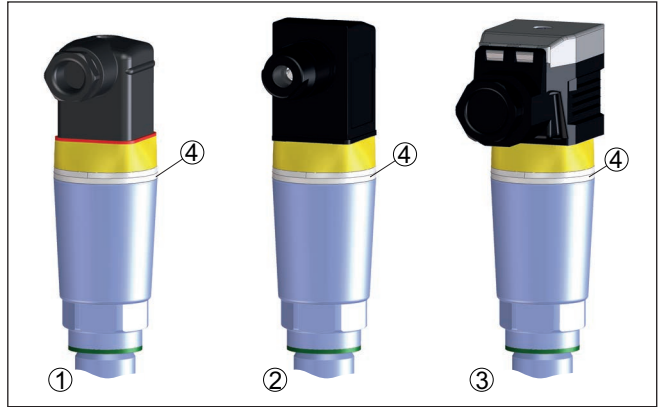

Fig. 5: Plug versions

- 1 Valve plug ISO 4400
- 2 Valve plug ISO 4400 with IDC method of termination
- 3 Valve plug ISO 4400 with hinged cover
- 4 LED illuminated ring

### Valve plug ISO 4400

For this plug version, standard cable with round wire cross-section can be used. Cable diameter 4.5 ... 7 mm, protection IP65.

1. Loosen the screw on the rear of the plug connector
2. Remove the plug connector and seal from VEGAPOINT 31
3. Remove the plug insert from the plug housing
4. Remove approx. 5 cm of the cable mantle, strip approx. 1 cm insulation from the individual wires
5. Lead the cable through the cable gland into the plug housing
6. Connect the wire ends to the screw terminals according to the wiring plan

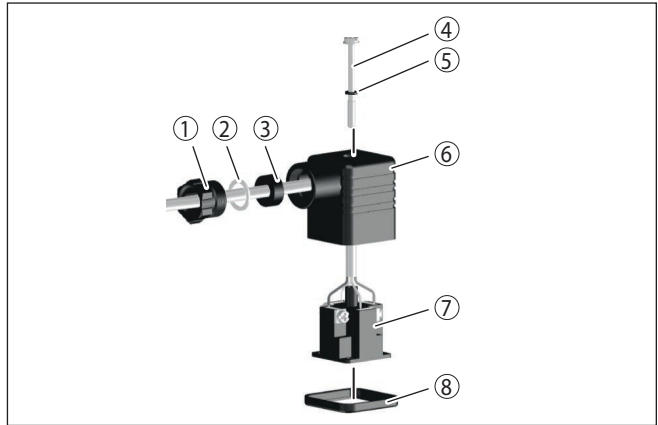

Fig. 6: Connection, valve plug ISO 4400

- 1 Pressure screw
- 2 Pressure disc
- 3 Seal ring
- 4 Fixing screw
- 5 Seal washer
- 6 Plug housing
- 7 Plug insert
- 8 Profile seal

7. Snap the plug insert into the plug housing and insert the sensor seal
8. Plug the plug insert with seal to VEGAPOINT 31 and tighten the screw

### Valve plug ISO 4400 with IDC method of termination

For this plug version you can use standard cable with round wire cross-section. The inner conductors do not have to be stripped. The plug connects the conductors automatically when screwing in. Cable diameter 5.5 ... 8 mm, protection IP67.

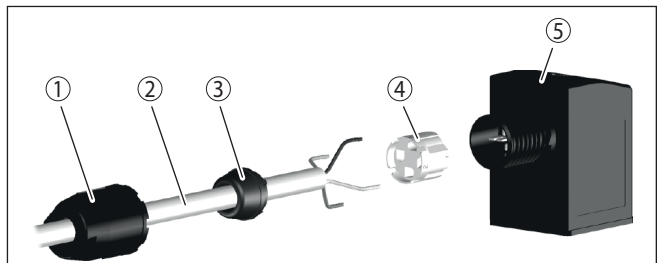

Fig. 7: Connection, valve plug ISO 4400 with IDC crimping technology

- 1 Compression nut
- 2 Cable
- 3 Seal ring
- 4 Terminal insert
- 5 Plug housing

## Valve plug ISO 4400 with hinged cover

For this plug version, standard cable with round wire cross-section can be used. Cable diameter 4.5 ... 7 mm, protection IP65.

1. Loosen the screw in the cover of the plug connector
2. Open the cover and remove it
3. Press the plug insert downwards
4. Loosen the screws of the strain relief and cable entry

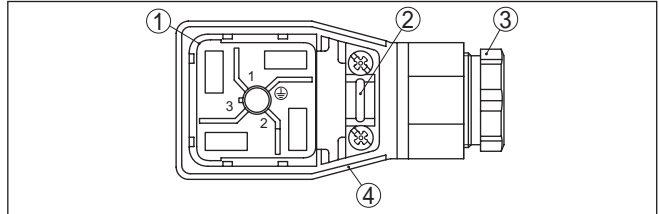

Fig. 8: Loosen the plug insert

- 1 Plug insert
- 2 Strain relief
- 3 Cable gland
- 4 Plug housing

5. Remove approx. 5 cm of the cable mantle, strip approx. 1 cm insulation from the individual wires
6. Lead the cable through the cable gland into the plug housing
7. Connect the wire ends to the screw terminals according to the wiring plan

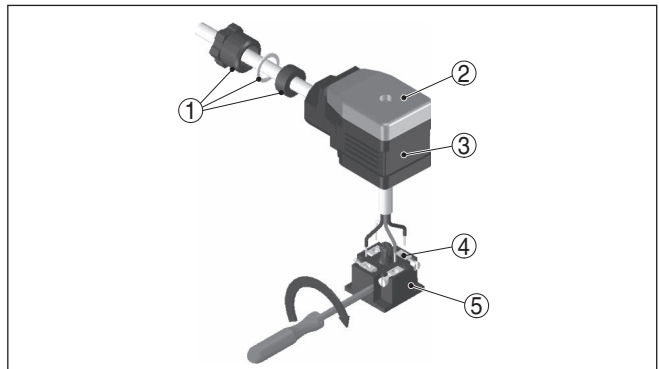

Fig. 9: Connection to the screw terminals

- 1 Cable gland
- 2 Cover
- 3 Plug housing
- 4 Plug insert
- 5 Plug seal

8. Snap the plug insert into the plug housing and insert the sensor seal



### Information:

Note the correct arrangement, see illustration

9. Tighten the screws on the strain relief and cable entry
10. Hook in the cover and push onto the plug connection, tighten cover screw
11. Plug the plug insert with seal to VEGAPOINT 31 and tighten the screw

### 5.3 Wiring plan

For connection to binary inputs of a PLC.

#### Valve plug ISO 4400

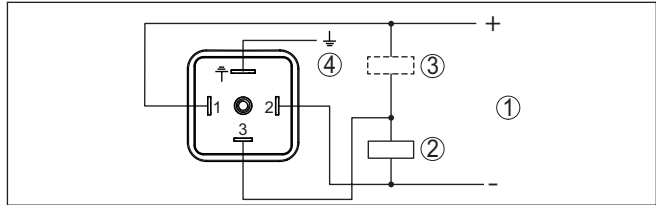

Fig. 10: Wiring plan connector ISO 4400 - transistor output three-wire

- 1 Voltage supply
- 2 PNP switching
- 3 NPN switching
- 4 PA - Potential equalisation

Contact, plug connector	Function/Polarity
1	Voltage supply/+
2	Voltage supply/-
3	Transistor output
4	PA - Potential equalisation

### 5.4 Switch-on phase

After switching on, the device first carries out a self-test in which the function of the electronics is checked.

The current measured value is then output on the signal cable.

## 6 Access protection

### 6.1 Bluetooth radio interface

Devices with a Bluetooth radio interface are protected against unwanted access from outside. This means that only authorized persons can receive measured and status values and change device settings via this interface.

#### Bluetooth access code

A Bluetooth access code is required to establish Bluetooth communication via the adjustment tool (smartphone/tablet/notebook). This code must be entered once when Bluetooth communication is established for the first time in the adjustment tool. It is then stored in the adjustment tool and does not have to be entered again.

The Bluetooth access code is individual for each device. It is printed on the device housing with Bluetooth. In addition, it is supplied with the device in the information sheet "*PINs and Codes*". In addition, the Bluetooth access code can be read out via the display and adjustment unit, depending on the device version.

The Bluetooth access code can be changed by the user after the first connection is established. If the Bluetooth access code is entered incorrectly, the new entry is only possible after a waiting period has elapsed. The waiting time increases with each further incorrect entry.

#### Emergency Bluetooth unlock code

The emergency Bluetooth access code enables Bluetooth communication to be established in the event that the Bluetooth access code is no longer known. It can't be changed. The emergency Bluetooth access code can be found in information sheet "*Access protection*". If this document is lost, the emergency Bluetooth access code can be retrieved from your personal contact person after legitimation. The storage and transmission of Bluetooth access codes is always encrypted (SHA 256 algorithm).

### 6.2 Protection of the parameterization

The settings (parameters) of the device can be protected against unwanted changes. The parameter protection is deactivated on delivery, all settings can be made.

#### Device code

To protect the parameterization, the device can be locked by the user with the aid of a freely selectable device code. The settings (parameters) can then only be read out, but not changed. The device code is also stored in the adjustment tool. However, unlike the Bluetooth access code, it must be re-entered for each unlock. When using the adjustment app or DTM, the stored device code is then suggested to the user for unlocking.

#### Emergency device code

The emergency device code allows unlocking the device in case the device code is no longer known. It can't be changed. The emergency device code can also be found on the supplied information sheet "*Access protection*". If this document is lost, the emergency device code can be retrieved from your personal contact person after legitimation.

The storage and transmission of the device codes is always encrypted (SHA 256 algorithm).

### **6.3 Storing the codes in myVEGA**

If the user has a "myVEGA" account, then the Bluetooth access code as well as the device code are additionally stored in his account under "*PINs and Codes*". This greatly simplifies the use of additional adjustment tools, as all Bluetooth access and device codes are automatically synchronized when connected to the "myVEGA" account

## 7 Setup

### 7.1 Indication of the switching status

The switching status of the electronics can be checked via the 360° status indication (LEDs) integrated in the upper part of the housing.

The colours of the 360° status indication have the following meaning:  
1)



- Green lights up - power supply connected, sensor output high-impedance
- Green flashing - Maintenance required
- Yellow lights up - power supply connected, sensor output low impedance
- Red lights - shortcircuit or overload in the load circuit (sensor output high-impedance)
- Red flashing - Error at sensor or electronics (sensor output high impedance) or device is in simulation

### 7.2 Function table

The following table provides an overview of the switching conditions depending on the set mode and the level.

The switching states correspond to the default setting.

The colours of the signal lamp correspond to the signalling according to NAMUR NE 107.

Coverage	Switching status Output 1	Switching status Output 2	360° status indication <sup>2)</sup>
Covered 	open	closed	Green
Uncovered 	closed	open	Yellow
Fault (Covered/Uncovered)	open	open	Red

### 7.3 Menu overview

#### Adjustment possibilities

There are several ways to operate the device.

The Bluetooth version (optional) of the instrument enables a wireless connection to standard adjustment units. This can be smartphones/

1) Default setting

2) Switching status of output 1

tablets with iOS or Android operating system or PCs with PACTware and Bluetooth USB adapter.

The following functional descriptions apply to all adjustment devices (smartphone, tablet, laptop ...).

For technical reasons, individual functions are not available on all devices. You can find information on this in the function description.

### General information

The adjustment menu is divided into three sections:

**Main menu:** Measurement loop name, application, display etc.

**Extended functions:** Output, switching output, reset etc.

**Diagnosis:** Status, peak indicator, simulation, sensor information etc.



#### Note:

Please note that individual menu items are only optionally available or depend on the settings in other menu items.

### Main menu

Menu item	Function	Default value
Measurement loop name	Free naming of the device	Sensor
Application	Selection of the application	Standard
Adjustment with medium <sup>3)</sup>	Media adjustment	Accept current device status

### Extended functions

Menu item	Function	Default value
Output	Transistor function (P-N)	PNP
	Function output (OU1)	Opener (HNC)
Switching output	Switching point (SP1)	85 %
	Switching delay (DS1)	0.5 s
	Reset point (RP1)	83 %
	Reset delay (DR1)	0.5 s
Indication	Brightness LED illuminated ring	100 %
	Signalling	NAMUR NE 107
	Fault	Red
	Switching output	Yellow
	Operating status	Green
Access protection	Bluetooth access code	See supplementary sheet "PINs and Codes".
	Protection of the parameterization	Deactivated
Reset	-	-
Units	Temperature unit	°C

3) Only for "User-defined" application

**Diagnostics**

Menu item	Function	Default value
Status	Device status Status output Parameter modification counter	OK OK Quantity
Peak indicator	Peak indicator resonance frequency Peak indicator measuring cell temperature Peak indicator, electronic temperature	- - -
Measured values	Menu item	-
Simulation	Menu item	-
Impedance curve	Menu item	-
Sensor information	Menu item	-
Sensor characteristics <sup>4)</sup>	Menu item	-

**7.4 Parameter adjustment**

**7.4.1 Main menu**

**Measurement loop name (TAG)**

Here you can assign a suitable measurement loop name. This name is stored in the sensor and is used to identify the device. You can enter names with max. 19 characters. The character set comprises:

- Upper and lower case letters from A ... Z
- Numbers from 0 ... 9
- Special characters and blanks

**Application**

In this menu item you can select the application. You can choose from the following applications:

- Standard
- User-defined



**Note:**

The selection of the application has a considerable influence on all other menu items. Keep in mind that as you continue with the parameter adjustment, individual menu items are only optionally available.

**Standard (level detection)**

If " *Standard* " is selected, an automatic adjustment is carried out. A manual adjustment is only necessary in special media.

**User-defined**

If you have selected the application *User-defined* you can adjust the switching states with the original medium or with the actual covering state.

4) Only DTM adjustment

Depending on the selected application, you can produce the corresponding occultation states and transfer them directly.

See function " *Adjustment with medium*".

## 7.4.2 Extended functions

### Output

In this menu item you can select the general settings for the output.

#### Transistor function

For devices with transistor output, you can set the function of the output.

- Functional principle PNP
- Functional principle NPN

With the outputs

#### Function output (OU1)

In this menu item you can set the function of the two outputs independently of each other.

Closing contact = HNO (Hysteresis Normally Open)

Opener = HNC (Hysteresis Normally Closed)

Closing contact = FNO (Window Normally Open)

Opener = FNC (Window Normally Closed)

#### Hysteresis function (HNO/HNC)

The hysteresis has the task of keeping the switching state of the output stable.

When the switching point (SP) is reached, the output switches and remains in this switching state. Only when the reset point (RP) is reached does the output switch back.

If the measured variable moves between switching and reset point, the state of the output does not change.

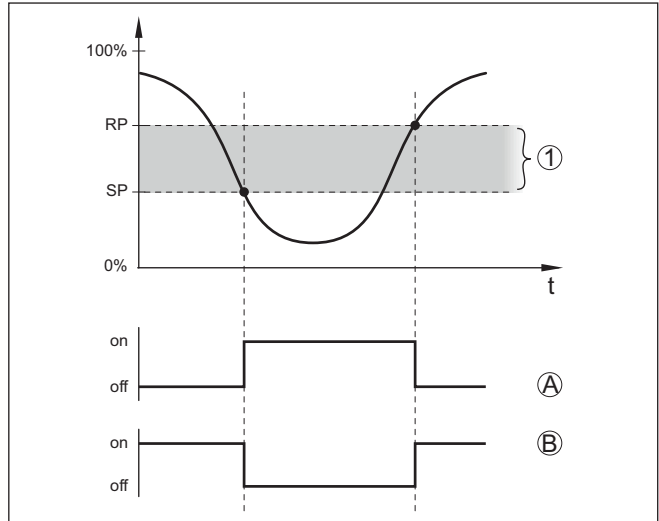

Fig. 11: Hysteresis function

SP Switching point

RP Reset point

A HNO (Hysteresis Normally Open) = Closing contact

B HNC (Hysteresis Normally Closed) = Opener

t Timeline

1 Hysteresis

### Window function (FNO/FNC)

With the window function (FNO and FNC) a nominal range, a so-called window, can be defined.

The output changes its state when the measured variable enters the window between the values Window High (FH) and Window Low (FL). If the measured variable leaves the window, the output returns to its previous state. If the measured variable moves within the window, the state of the output does not change.

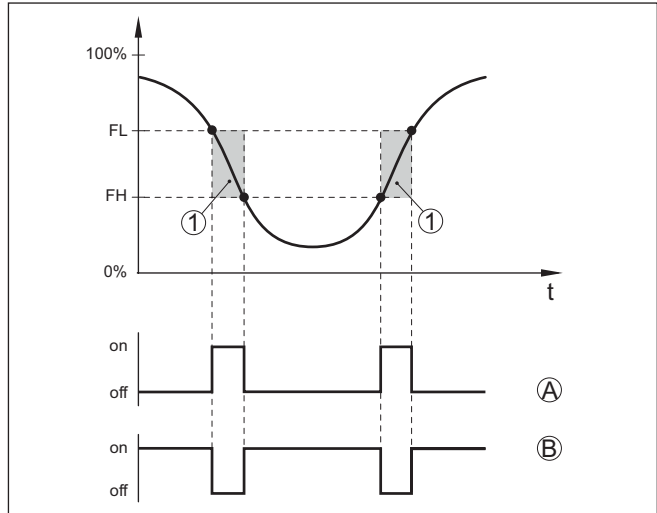

Fig. 12: Window function

FH Window high - upper value

FL Window low - lower value

A FNO (Window Normally Open) = Closing contact

B FNC (Window Normally Closed) = Opener

t Timeline

1 Window area

## Switching output

In this menu item, you can select the settings for the switching output. This is only possible if *User-defined* was selected in the application.

In the function "*Impedance curve*" you can see the changes and the position of the hysteresis.

- Switching point (SP1)
- Reset point (RP1)
- Switching delay (DS1)
- Reset delay (DR1)

### Switching point (SP1)

The switching point (SP1) indicates the switching threshold of the sensor related to the immersion depth or the degree of coverage.

The percentage defines the lower range limit of the hysteresis.

The setting is a degree for the sensitivity of the sensor tip.

### Reset point (RP1)

The reset point (RP) controls the sensitivity of the sensor when the sensor tip becomes free.

The percentage defines the upper range limit of the hysteresis.

The setting is a degree for the sensitivity of the sensor tip.

**Switching delay (DS1)**

The switching delay (DS) extends the reaction time until the sensor is switched over when the sensor tip is covered.

You can enter a delay time from 0 to 60 seconds.

**Reset delay (DR1)**

The reset delay (DR) extends the reaction time until the sensor switches over when the sensor tip becomes free.

You can enter a delay time from 0 to 60 seconds.

**360° status indication**

With this menu item you can set the function of the 360° status indication.

- Brightness of the 360° status indication
- Signalling

**Brightness of the 360° status indication**

Brightness selection in 10 percent increments (0 %, 10 %, 20 %, 30 %, 40 % ... 100 %)

**Signalling**

Acc. to NAMUR NE 107

In this menu item you can select the standardized signalling according to NAMUR NE 107 or an individual signalling.

If you have selected signalling according to NAMUR NE 107, the signalling is set as follows:

- Failure/malfunction - Red
- Operating status/output 1 closed - Yellow
- Operating status/output 1 open - Green

In addition there are the following status indications:

- Simulation - red flashing
- Maintenance required - green flashing

**Individual signalling**

If you have selected "Individual signaling", you can select the respective LED colour separately for the following switching states.

- Fault
- Switching output
- Operating status

The following colours are available:

Red, yellow, green, blue, white, orange, no signalling. You can also set all colours individually in addition.

You can also have every status displayed flashing additionally.

**Access protection**

You can use the " *Access protection*" function to block or release access via the Bluetooth interface.

**Bluetooth access code**

With the function " *Bluetooth access code*" you can release the Bluetooth data connection.

To activate the function, you must enter the six-digit access code.

You can find the Bluetooth access code in the " *PINs and Codes*" sheet of the shipping documentation.

See also chapter " *Access protection*".

### Protection of the parameterization

In this menu item you can also protect the parameter adjustment of the sensor.

For this function you need the six-digit device code.

The device code can also be found in the " *PINs and Codes*" sheet of the shipping documentation.

See also chapter " *Access protection*".

## Reset

After a reset, parameter adjustments made by the user are reset.

The following reset functions are available:

**Restore basic settings:** Resetting the parameter settings incl. special parameters to the default values of the respective device.

**Restore delivery status:** Restores the parameter settings at the time of shipment from the factory, incl. order-specific settings. This menu item is only available if order-specific settings have been made ex factory.



### Note:

The default values set at the factory can be found in the table of the menu plan at the beginning of this chapter.

## Units

In this menu item you can define the temperature unit of the device (UNI).

- °C
- °F

### 7.4.3 Diagnostics

## Status

In this menu item you can retrieve the status of the device.

- Device status
- Status outputs
- Parameter modification counter

The display " *Device status*" provides an overview of the current status of the device.

If fault messages or other information are available, a corresponding message is displayed here.

The display " *Status outputs*" gives an overview of the current status of the device outputs.

The menu item " *Parameter change counter*" gives a quick overview if the parameter adjustment of the device was changed.

The value is increased by one each time the parameters of the device are changed. The value is retained in the event of a reset.

## Peak indicator

In this menu item you can retrieve the peak indicator of the device.

For each peak indicator there is a max. and a min. value.

In addition, the current value is displayed.

- Peak indicator, electronic temperature
- Peak indicator measuring cell temperature
- Peak indicator resonance frequency

In this window you can also reset each of the three peak indicator individually.

## Measured values

In this menu item you can retrieve the current measured values of the device.

### Measured values

Here you can view the current coverage status of the device (covered/uncovered).

### Additional measured values

Here you can find additional measured values of the device.

- Electronic temperature (°C/°F)
- Measuring cell temperature (°C/°F)
- Resonance frequency (%)

### Outputs

Here you can retrieve the current switching status of the output (closed/open).

- Output

## Function test

In this menu item you can start an annual function test according to WHG.

The function test serves as proof of the recurring test in accordance with the approval for overflow protections.

The function test is only active if the device has WHG approval.

In order to output the complete documentation, the function test is only possible in PACTware.

Further information can be found in the approval documentation according to WHG.



### Note:

Note that the measuring function of the sensor is disabled for the duration of the function test and that downstream devices are activated during the function test.

Start the function test by clicking the button " *Start proof test*".

Check the correct reaction of the output and the downstream devices. During the function test, the 360° status display flashes red.

After the function test has been completed, you can save a PDF file containing all device data and adjustment parameters at the time of the function test.

## Simulation

In this menu item you can simulate the function of the two switching outputs separately.

**Note:**

Make sure the connected downstream devices are activated during the simulation.

First select the desired switching output and start the simulation.

Then select the desired switching state.

- Open
- Closed

Click on the button "Accept simulation value".

The sensor now switches to the desired simulation switching status.

During simulation, the LED display flashes in the colour of the selected switching status.

A simulation of the fault status is not possible.

To cancel the simulation, click on "Terminate simulation".

**Note:**

Without manual deactivation, the sensor terminates the simulation automatically after 60 minutes.

**Impedance curve**

In this menu item you can see the impedance curve of the device.

The impedance curve gives information about the switching behaviour of the sensor.

At the lowest point of the black curve is the current switching point (resonance point).

**Sensor information**

In this menu item you can retrieve the sensor information of the device.

- Device name
- Serial number
- Hardware version
- Software version
- Factory calibration date
- Device Revision
- Sensor acc. to WHG

**Sensor characteristics**

In this menu item you can retrieve the sensor features of the device.

This menu item can only be selected via PACTware with DTM.

- Order texts
- Instrument version
- Electronics
- etc.

## 8 Setup with smartphone/tablet (Bluetooth)

### 8.1 Preparations

#### System requirements

Make sure that your smartphone/tablet meets the following system requirements:

- Operating system: iOS 8 or newer
- Operating system: Android 5.1 or newer
- Bluetooth 4.0 LE or newer

Download the VEGA Tools app from the "Apple App Store", "Google Play Store" or "Baidu Store" to your smartphone or tablet.

### 8.2 Connecting

#### Connecting

Start the adjustment app and select the function "Setup". The smartphone/tablet searches automatically for Bluetooth-capable instruments in the area.

The message "Connecting ..." is displayed.

The devices found are listed and the search is automatically continued.

Select the requested instrument in the device list.

As soon as the Bluetooth connection to a device is established, the LED display of the device in question flashes blue 4 times.

#### Authenticate

When establishing the connection for the first time, the operating tool and the sensor must authenticate each other. After the first correct authentication, each subsequent connection is made without a new authentication query.

#### Enter Bluetooth access code

For authentication, enter the 6-digit Bluetooth access code in the next menu window. You can find the code on the outside of the device housing and on the information sheet "Pins and Codes" in the device packaging.

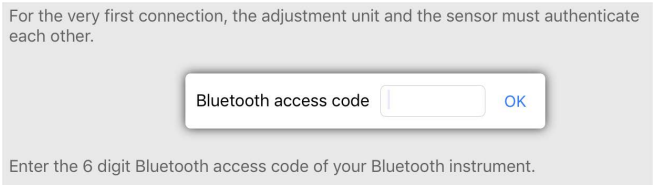

Fig. 13: Enter Bluetooth access code



#### Note:

If an incorrect code is entered, the code can only be entered again after a delay time. This time gets longer after each incorrect entry.

The message "Waiting for authentication" is displayed on the smartphone/tablet.

#### Connected

After connection, the sensor adjustment menu is displayed on the respective adjustment tool.

If the Bluetooth connection is interrupted, e.g. due to a too large distance between the two devices, this is displayed on the adjustment tool. The message disappears when the connection is restored.

### Change device code

Parameter adjustment of the device is only possible if the parameter protection is deactivated. When delivered, parameter protection is deactivated by default and can be activated at any time.

It is recommended to enter a personal 6-digit device code. To do this, go to menu " *Extended functions*", " *Access protection*", menu item " *Protection of the parameter adjustment*".

## 8.3 Sensor parameter adjustment

### Enter parameters

The sensor adjustment menu is divided into two halves:

On the left you'll find the navigation section with the menus " *Setup*", " *Diagnosis*" and others.

The selected menu item, recognisable by the colour change, is displayed in the right half.

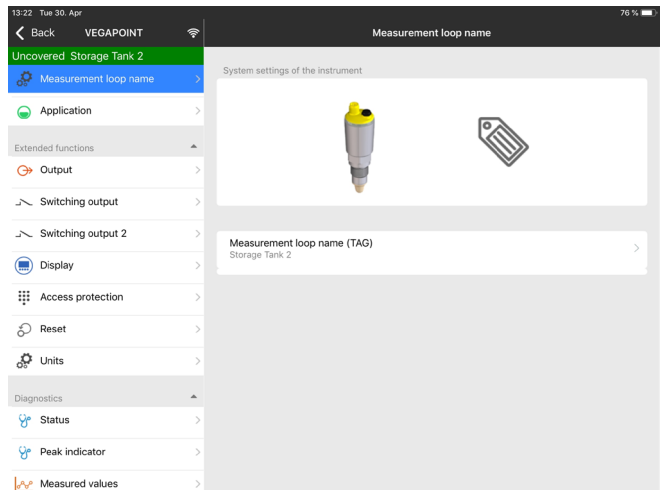

Fig. 14: Example of an app view - Setup

## 9 Setup with PC/notebook (Bluetooth)

### 9.1 Preparations

#### System requirements

Make sure that your PC/notebook meets the following system requirements:

- Operating system Windows 10
- DTM Collection 10/2020 or newer
- Bluetooth 4.0 LE or newer

#### Activate Bluetooth connection

Activate the Bluetooth connection via the project assistant.



#### Note:

Older systems do not always have an integrated Bluetooth LE. In these cases, a Bluetooth USB adapter is required. Activate the Bluetooth USB adapter using the Project Wizard.

After activating the integrated Bluetooth or the Bluetooth USB adapter, devices with Bluetooth are found and created in the project tree.

### 9.2 Connecting

#### Connecting

Select the requested device for the online parameter adjustment in the project tree.

As soon as the Bluetooth connection to a device is established, the LED display of the device in question flashes blue 4 times.

#### Authenticate

When establishing the connection for the first time, the operating tool and the device must authenticate each other. After the first correct authentication, each subsequent connection is made without a new authentication query.

#### Enter Bluetooth access code

For authentication, enter in the next menu window the 6-digit Bluetooth access code:

Fig. 15: Enter Bluetooth access code

You can find the code on the outside of the device housing and on the information sheet "PINs and Codes" in the device packaging.



**Note:**

If an incorrect code is entered, the code can only be entered again after a delay time. This time gets longer after each incorrect entry.

The message "Waiting for authentication" is displayed on the PC/notebook.

**Connected**

After connection, the device DTM appears.

If the connection is interrupted, e.g. due to a too large distance between device and adjustment tool, this is displayed on the adjustment tool. The message disappears when the connection is restored.

**Change device code**

Parameter adjustment of the device is only possible if the parameter protection is deactivated. When delivered, parameter protection is deactivated by default and can be activated at any time.

It is recommended to enter a personal 6-digit device code. To do this, go to menu "Extended functions", "Access protection", menu item "Protection of the parameter adjustment".

### 9.3 Sensor parameter adjustment

**Enter parameters**

The sensor adjustment menu is divided into two halves:

On the left you'll find the navigation section with the menus "Setup", "Display", "Diagnosis" and others.

The selected menu item, recognisable by the colour change, is displayed in the right half.

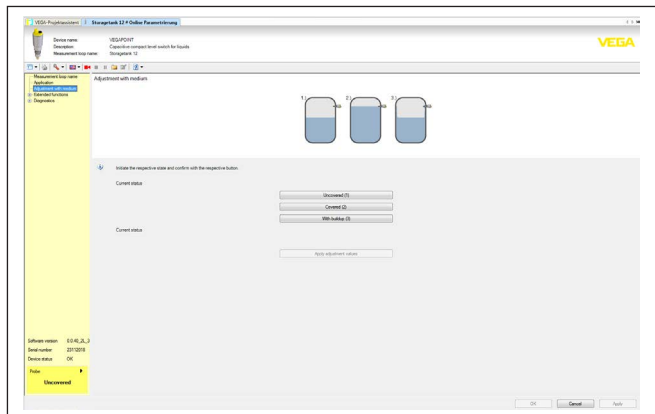

Fig. 16: Example of a DTM view - Setup

## 10 Diagnostics and servicing

### 10.1 Maintenance

#### Maintenance

If the device is used properly, no special maintenance is required in normal operation.

#### Cleaning

The cleaning helps that the type label and markings on the instrument are visible.

Take note of the following:

- Use only cleaning agents which do not corrode the housings, type label and seals
- Use only cleaning methods corresponding to the housing protection rating

### 10.2 Rectify faults

#### Reaction when malfunction occurs

The operator of the system is responsible for taking suitable measures to rectify faults.

#### Causes of malfunction

The device offers maximum reliability. Nevertheless, faults can occur during operation. These may be caused by the following, e.g.:

- Sensor
- Process
- Voltage supply
- Signal processing

#### Fault rectification

The first measures are:

- Evaluation of fault messages
- Checking the output signal
- Treatment of measurement errors

A smartphone/tablet with the adjustment app or a PC/notebook with the software PACTware and the suitable DTM offer you further comprehensive diagnostic possibilities. In many cases, the causes can be determined in this way and the faults eliminated.

#### Reaction after fault rectification

Depending on the reason for the fault and the measures taken, the steps described in chapter "Setup" must be carried out again or must be checked for plausibility and completeness.

#### 24 hour service hotline

Should these measures not be successful, please call in urgent cases the VEGA service hotline under the phone no. **+49 1805 858550**.

The hotline is also available outside normal working hours, seven days a week around the clock.

Since we offer this service worldwide, the support is provided in English. The service itself is free of charge, the only costs involved are the normal call charges.

### 10.3 Diagnosis, fault messages

#### Checking the switching signal

The 360° status indication on the device indicates the operating status of the device (display according to NE 107). At the same time it indicates the switching state of the output. This enables simple on-site diagnosis without the need for tools.

Error	Cause	Rectification
Green signal lamp off	Voltage supply interrupted.	Check voltage supply and cable connection
	Electronics defective	Exchange the instrument or send it in for repair
Green signal lamp flashes	Maintenance required	Carry out maintenance
Red signal lamp lights (switching output high-impedance)	Error with the electrical connection	Connect device according to wiring plan
	Shortcircuit or overload	Check electrical connection
	Measuring tip damaged	Check whether the measuring tip is damaged
Red signal lamp flashes (switching output high-impedance)	Sensor outside the specification	Check sensor adjustment Switching points may be interchanged
	Sensor is in simulation mode	Terminate simulation mode

#### Error messages



#### Information:

You can find the current device status and possibly an error code in the operating app under Diagnosis - Status - Device Status.

Failure/Error		
Red control lamp lights up		
Error	Cause	Rectification
F013	no measured value available	Error in the electronics Restart instrument If the error occurs again, replace the device
F036	no operable sensor software	Software update aborted or faulty Repeat software update
F080	General software error	Restart instrument
F105	Measured value is determined	Device is still in the switch-on phase Wait until the device is ready for operation
F111	Switching points interchanged	Repeat sensor adjustment The switching point (SP) must be smaller than the reset point (RP)
F260	Error in the calibration	Repeat device adjustment
F261	Error in the instrument settings	Carry out device reset Reset device to delivery status

Out of specification Red signal lamp flashes		
Error	Cause	Rectification
S600	Electronics temperature too high	Error in the electronics Allow device to cool down and restart If the error occurs again, check the ambient temperature
S604	Overload on output	Switching output overloaded Check electrical connection Reduce switching load

Maintenance required Green signal lamp flashes		
Error	Cause	Rectification
M511	Inconsistent software	Software faulty Carry out software update

Function check Red signal lamp flashes		
Error	Cause	Rectification
C700	Simulation active	Terminate simulation mode

### 10.4 Status messages according to NE 107

The instrument features self-monitoring and diagnostics according to NE 107 and VDI/VDE 2650. In addition to the status messages in the following tables there are more detailed error messages available under the menu item "Diagnostics" via DTM or app.

#### Status messages

The status messages are divided into the following categories:

- Failure
- Function check
- Out of specification
- Maintenance required

and explained by pictographs:

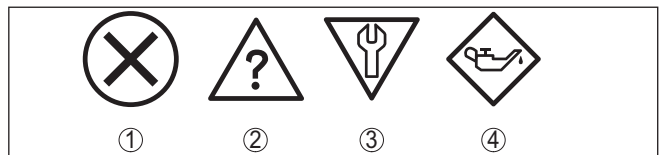

Fig. 17: Pictographs of the status messages

- 1 Failure - red
- 2 Out of specification - yellow
- 3 Function check - orange
- 4 Maintenance required - blue

**Malfunction (Failure):**

Due to a malfunction in the instrument, a fault signal is output.

This status message is always active. It cannot be deactivated by the user.

**Function check:**

The instrument is being worked on, the measured value is temporarily invalid (for example during simulation).

This status message is inactive by default.

**Out of specification:**

The measured value is unreliable because an instrument specification was exceeded (e.g. electronics temperature).

This status message is inactive by default.

**Maintenance required:**

Due to external influences, the instrument function is limited. The measurement is affected, but the measured value is still valid. Plan in maintenance for the instrument because a failure is expected in the near future (e.g. due to buildup).

This status message is inactive by default.

**Failure**

<b>Code</b> <b>Text message</b>	<b>Cause</b>	<b>Rectification</b>
F013 no measured value available	Error in capacitive measurement	Send instrument for repair
F036 No operable software	Wrong software type Software update not successful or aborted	Repeat software update
F080 General software error	Software error	Restart instrument
F105 Measured value is determined	Device is still in the switch-on phase	Wait for the end of the switch-on phase
F260 Error in the calibration	Error in the calibration carried out in the factory Error in the EEPROM	Send instrument for repair
F261 Error in the instrument settings	Checksum error in the configuration values	Carry out a reset

**Function check**

<b>Code</b> <b>Text message</b>	<b>Cause</b>	<b>Rectification</b>
C700 Simulation active	A simulation is active	Finish simulation Wait for the automatic end after 60 mins.

**Out of specification**

Code Text message	Cause	Rectification
S600 Impermissible electronics temperature	Temperature of the electronics in the non-specified range	Check ambient temperature Insulate electronics
S604 Switching output overloaded	Overload or short circuit on the switching output	Check electrical connection

**Maintenance**

Code Text message	Cause	Rectification
M511 Inconsistent software configuration	Software faulty or outdated	Carry out software update

**10.5 Software update**

The device software is updated via Bluetooth.

The following components are required:

- Instrument
- Voltage supply
- PC/notebook with PACTware/DTM and Bluetooth USB adapter
- Current instrument software as file

You can find the current instrument software as well as detailed information on the procedure in the download area of our homepage.



**Caution:**

Instruments with approvals can be bound to certain software versions. Therefore make sure that the approval is still effective after a software update is carried out.

You can find detailed information in the download area on our homepage.

**10.6 How to proceed if a repair is necessary**

You can find an instrument return form as well as detailed information about the procedure in the download area of our homepage. By doing this you help us carry out the repair quickly and without having to call back for needed information.

Proceed as follows in case of repair:

- Print and fill out one form per instrument
- Clean the instrument and pack it damage-proof
- Attach the completed form and, if need be, also a safety data sheet outside on the packaging
- Ask the agency serving you to get the address for the return shipment. You can find the agency on our homepage.

## 11 Dismount

### 11.1 Dismounting steps

To remove the device, carry out the steps in chapters " *Mounting*" and " *Connecting to power supply*" in reverse.



**Warning:**

When dismantling, pay attention to the process conditions in vessels or pipelines. There is a risk of injury, e.g. due to high pressures or temperatures as well as aggressive or toxic media. Avoid this by taking appropriate protective measures.

### 11.2 Disposal



Pass the instrument on to a specialised recycling company and do not use the municipal collecting points.

Remove any batteries in advance, if they can be removed from the device, and dispose of them separately.

If personal data is stored on the old device to be disposed of, delete it before disposal.

If you have no way to dispose of the old instrument properly, please contact us concerning return and disposal.

## 12 Certificates and approvals

### 12.1 Radio licenses

#### Bluetooth

The Bluetooth radio module in the device has been tested and approved according to the current edition of the applicable country-specific norms or standards.

The confirmations as well as regulations for use can be found in the document "*Radio licenses*" supplied or on our homepage.

### 12.2 Food and pharmaceutical certificates

Versions for use in the food and pharmaceutical industries are available or in preparation for the device or the device series.

The corresponding certificates can be found on our homepage.

### 12.3 Conformity

The device complies with the legal requirements of the applicable country-specific directives or technical regulations. We confirm conformity with the corresponding labelling.

The corresponding conformity declarations can be found on our homepage.

#### Electromagnetic compatibility

The instruments are designed for use in an industrial environment. Nevertheless, electromagnetic interference from electrical conductors and radiated emissions must be taken into account, as is usual with a class A instrument according to EN 61326-1.

When the device is mounted in metal containers or tubes, the interference resistance requirements of IEC/EN 61326 for "Industrial environment" and the NAMUR recommendation EMC (NE21) are met.

If the device is to be used in other environments, the electromagnetic compatibility to other devices must be ensured by suitable measures.

### 12.4 Environment management system

Protection of the environment is one of our most important duties. That is why we have introduced an environment management system with the goal of continuously improving company environmental protection. The environment management system is certified according to DIN EN ISO 14001.

Help us to meet these requirements and observe the environmental instructions in the chapters "*Packaging, transport and storage*", "*Disposal*" of this operating instructions.

## 13 Supplement

### 13.1 Technical data

#### Note for approved instruments

The technical data in the respective safety instructions which are included in delivery are valid for approved instruments (e.g. with Ex approval). These data can differ from the data listed herein, for example regarding the process conditions or the voltage supply.

All approval documents can be downloaded from our homepage.

#### Materials and weights

Material 316L corresponds to 1.4404

Materials, wetted parts

- |                                  |                   |
|----------------------------------|-------------------|
| – Sensor tip                     | PEEK, polished    |
| – Device seal - Standard version | FKM               |
| – Device seal - Hygienic version | EPDM              |
| – Process seal                   | Klingersil C-4400 |
| – Process fittings               | 316L              |

Materials, non-wetted parts

- |   |  |
|---|--|
| – Housing   | 316L and plastic (Valox and polycarbonate) |
| – Device seal - Hygienic design AC and AM <sup>5)</sup> | EPDM                                       |
| – Seal plug   | NBR  |

Weight approx. 250 g (0.55 lbs)

#### General data

Process fittings

- |  |                            |
|--|----------------------------|
| – Pipe thread, cylindrical (DIN 3852-A) or ISO 228-1 | G½, G¾, G1                 |
| – Pipe thread, conical (ASME B1.20.1)                | ½ NPT, ¾ NPT, 1 NPT        |
| – Metric fine thread, cylindrical                    | M24 x 1.5                  |
| – Clamp  | 1", 1½", 2"                |
| – Collar socket DIN 11851, PN 40                     | DN 25, DN 32, DN 40        |
| – Hygienic fitting                                   | RD 52 PN 25 with union nut |
| – Varivent   | N50-40 PN 25, F25 PN 25    |

Threaded and hygienic adapter

- |                             |   |
|-----------------------------|---|
| – Standard hygienic adapter | G½, G1  |
|                             | Other connections via hygiene adapters possible |

Max. torque - process fitting

- |                    |                    |
|--------------------|--------------------|
| – Thread G½, ½ NPT | 50 Nm (37 lbf ft)  |
| – Thread G¾, ¾ NPT | 75 Nm (55 lbf ft)  |
| – Thread G1, 1 NPT | 100 Nm (73 lbf ft) |

5) not in contact with the medium

- Hygienic adapter	20 Nm (15 lbf ft)
Surface quality	$R_a < 0.76 \mu\text{m}$ ( $3.00 \cdot 10^{-5}$ in)

---

### Measurement accuracy

---

Hysteresis	approx. 1 mm (0.04 in)
Switching delay	approx. 500 ms (on/off) Adjustable: 0.5 ... 60 s
Repetitive accuracy	$\pm 1 \text{ mm}$ ( $\pm 0.04 \text{ in}$ )

---

### Ambient conditions

---

Ambient temperature on the housing	-40 ... +70 °C (-40 ... +158 °F)
Storage and transport temperature	-40 ... +80 °C (-40 ... +176 °F)

---

### Mechanical environmental conditions

---

Sinusoidal oscillations according to EN 60068-2-6 (vibration at resonance)	4M8 (5 g) at 4 ... 200 Hz
Impacts	50 g, 2.3 ms according to EN 60068-2-27 (mechanical shock)
Impact resistance	
- Standard version	IK07 acc. to IEC 62262
- Full metal version	IK07 acc. to IEC 62262
- With protective cover	IK07 acc. to IEC 62262

---

### Process conditions

---

Process pressure	-1 ... 25 bar/-100 ... 2500 kPa (-14.5 ... 363 psig)
Process temperature	-40 ... +115 °C (-40 ... +239 °F)

### SIP process temperature (SIP = Sterilization in place)

Vapour stratification up to 1 h	+135 °C (+275 °F)
Dielectric constant	$\geq 1.5$

---

### Indication (NE 107)

---

360° status indication (LED)	
- Green	Power supply on - Output 1 open
- Yellow	Power supply on - Output 1 closed
- Red	Voltage supply on - failure/simulation

---

### Adjustment

---

Adjustment possibilities	App (Android/OS), PACTware/DTM
--------------------------	--------------------------------

---

### Output variable - Transistor output

---

Output	Transistor output NPN/PNP
Load current	max. 250 mA (output, permanently short-circuit proof)
Voltage loss	< 3 V
Switching voltage	< 34 V DC

Blocking current < 10  $\mu$ A

### Voltage supply

Operating voltage 12 ... 35 V DC  
 Max. power consumption 1 W  
 Reverse voltage protection Integrated  
 Max. power consumption 1 W

### Bluetooth interface

Bluetooth standard Bluetooth 5.0  
 Frequency 2.402 ... 2.480 GHz  
 Max. emitted power +2.2 dBm  
 Max. number of participants 1  
 Effective range typ.<sup>6)</sup> 25 m (82 ft)

### Electromechanical data

Valve plug ISO 4400  
 – Wire cross-section 1.5 mm<sup>2</sup> (0.06 in<sup>2</sup>)  
 – Outer cable diameter 4.5 ... 7 mm (0.18 ... 0.28 in)

Valve plug ISO 4400 with IDC method of termination  
 – Version 4-pin according to ISO 4400  
 – Wire cross-section 0.5 ... 1 mm<sup>2</sup> (AWG 20 ... AWG 17)  
 – Strand diameter > 0.1 mm (0.004 in)  
 – Wire diameter 1.6 ... 2 mm<sup>2</sup> (0.06 ... 0.08 in<sup>2</sup>)  
 – Outer cable diameter 5.5 ... 8 mm (0.22 ... 0.31 in)  
 – Connection frequency 10 x (on the same cross-section)

Valve plug ISO 4400 with hinged cover  
 – Wire cross-section 1.5 mm<sup>2</sup> (0.06 in<sup>2</sup>)  
 – Outer cable diameter 4.5 ... 11 mm (0.18 ... 0.43 in)

### Electrical protective measures

Potential separation Electronics potential free up to 500 V AC  
 Protection rating

Connection technology	Protection according to EN 60529/IEC 529	Protection according to UL 50
Plug according to ISO 4400	IP65	NEMA 4X
Plug according to ISO 4400 with IDC method of termination	IP67	NEMA 4X
ISO 4400 plug with hinged cover	IP65	NEMA 4X

Altitude above sea level up to 5000 m (16404 ft)

6) Depending on the local conditions

Protection class	III
Pollution degree	4

### 13.2 Dimensions

#### VEGAPOINT 31, standard version - thread

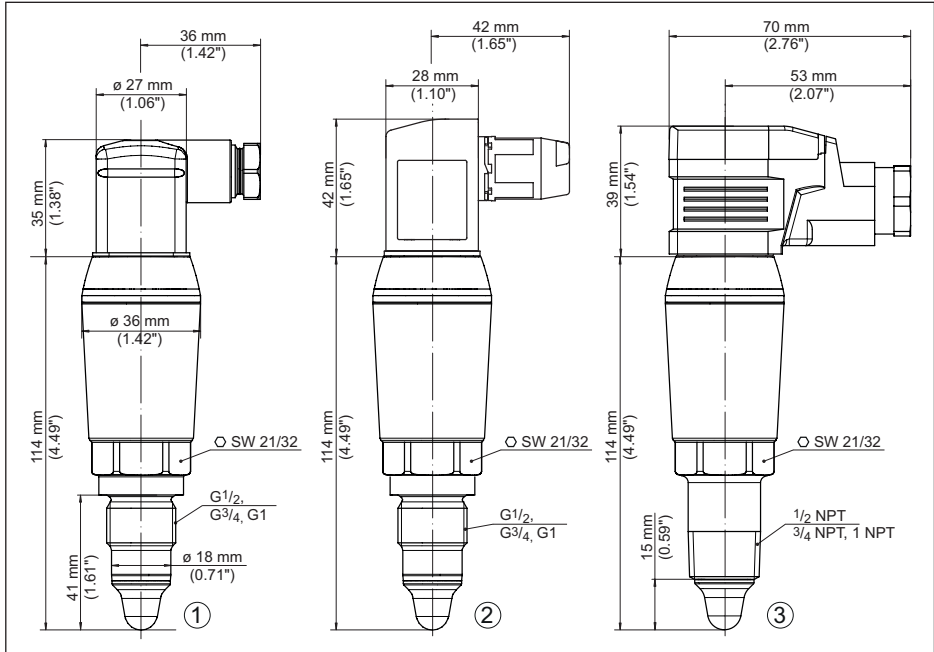

Fig. 18: VEGAPOINT 31, standard version - thread with valve plugs acc. to ISO 4400

- 1 Thread G1/2, G3/4, G1 (DIN ISO 228/1) with ISO 4400 valve plug
- 2 Thread G1/2, G3/4, G1 (DIN ISO 228/1) with ISO 4400 valve plug with IDC method of termination
- 3 Tread 1/2 NPT, 3/4 NPT, 1 NPT with ISO 4400 valve plug with hinged cover

## VEGAPOINT 31, hygienic version - Thread

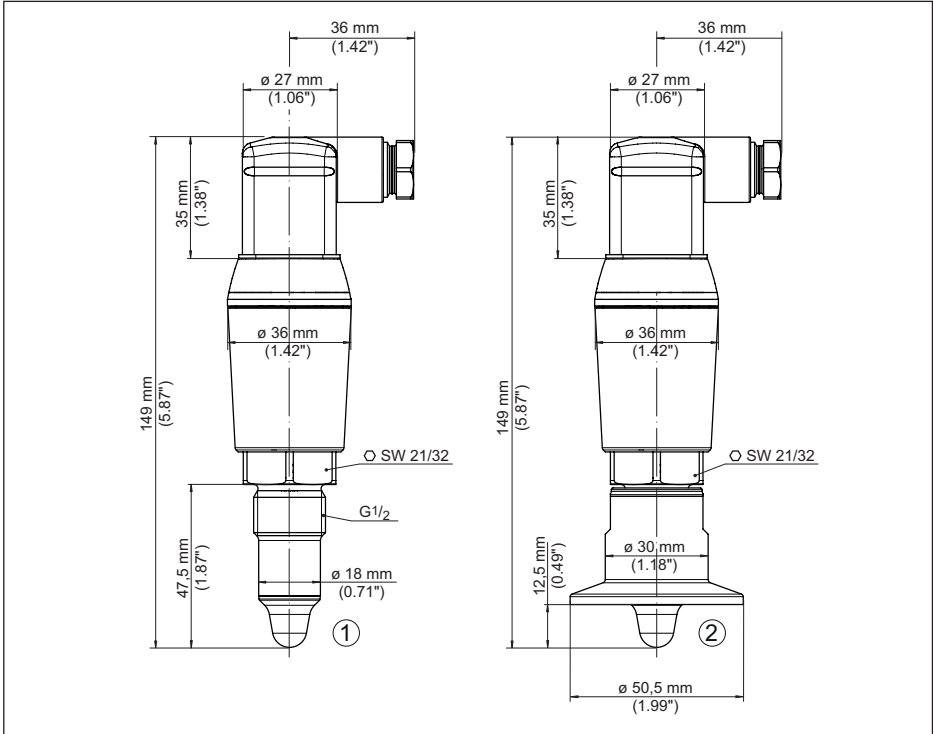

Fig. 19: VEGAPOINT 31, hygienic version - thread with ISO 4400 plug

- 1 Thread G $\frac{1}{2}$  for hygienic threaded adapter (DIN ISO 228/1) with ISO 4400 plug connection
- 2 VEGAPOINT 31, hygienic version in threaded adapter, Clamp

### 13.3 Industrial property rights

VEGA product lines are global protected by industrial property rights. Further information see [www.vega.com](http://www.vega.com).

VEGA Produktfamilien sind weltweit geschützt durch gewerbliche Schutzrechte.

Nähere Informationen unter [www.vega.com](http://www.vega.com).

Les lignes de produits VEGA sont globalement protégées par des droits de propriété intellectuelle. Pour plus d'informations, on pourra se référer au site [www.vega.com](http://www.vega.com).

VEGA lineas de productos están protegidas por los derechos en el campo de la propiedad industrial. Para mayor información revise la pagina web [www.vega.com](http://www.vega.com).

Линии продукции фирмы ВЕГА защищаются по всему миру правами на интеллектуальную собственность. Дальнейшую информацию смотрите на сайте [www.vega.com](http://www.vega.com).

VEGA系列产品在全球享有知识产权保护。

进一步信息请参见网站 < [www.vega.com](http://www.vega.com)。

### 13.4 Licensing information for open source software

Open source software components are also used in this device. A documentation of these components with the respective license type, the associated license texts, copyright notes and disclaimers can be found on our homepage.

### 13.5 Trademark

All the brands as well as trade and company names used are property of their lawful proprietor/originator.

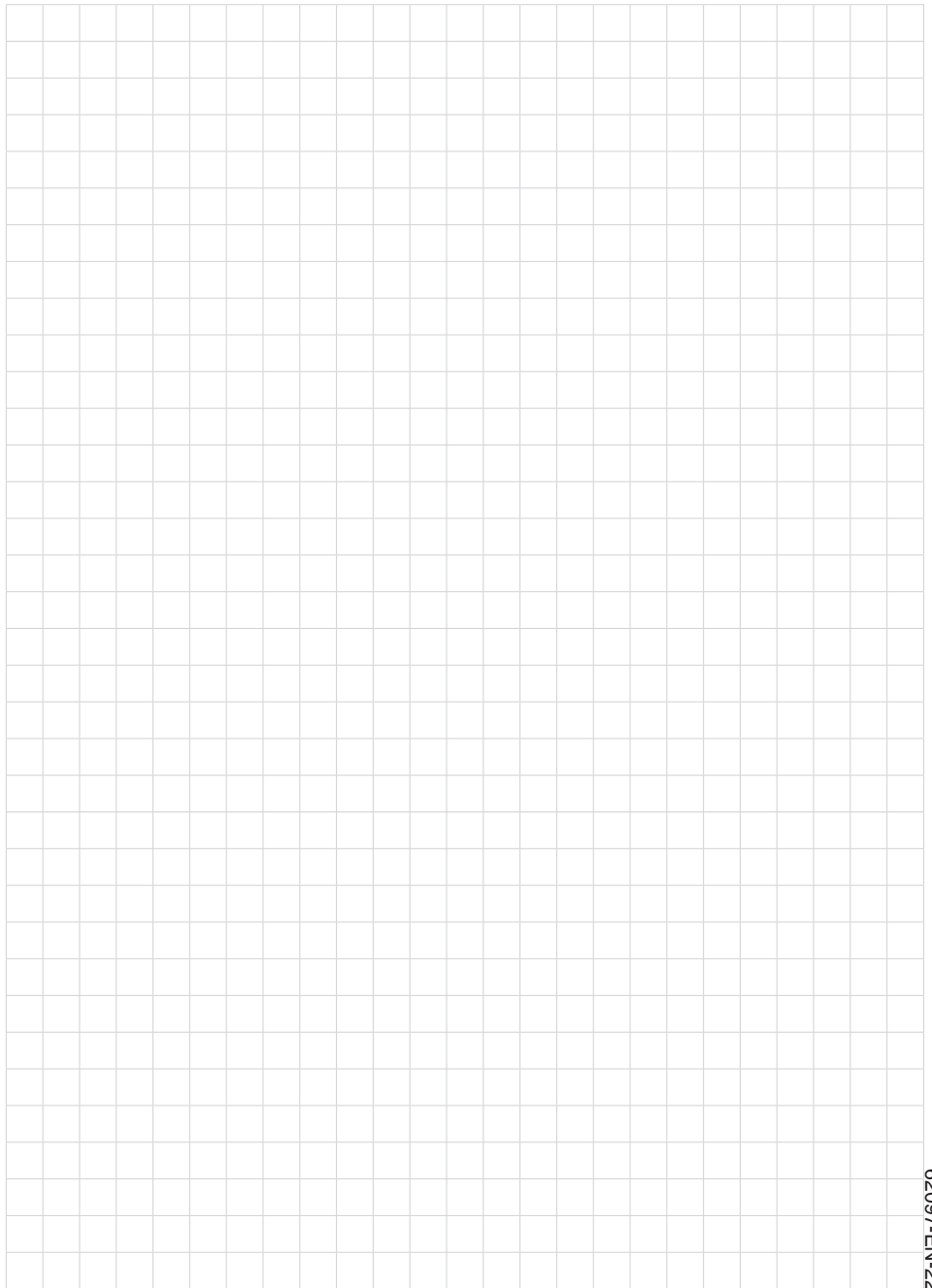

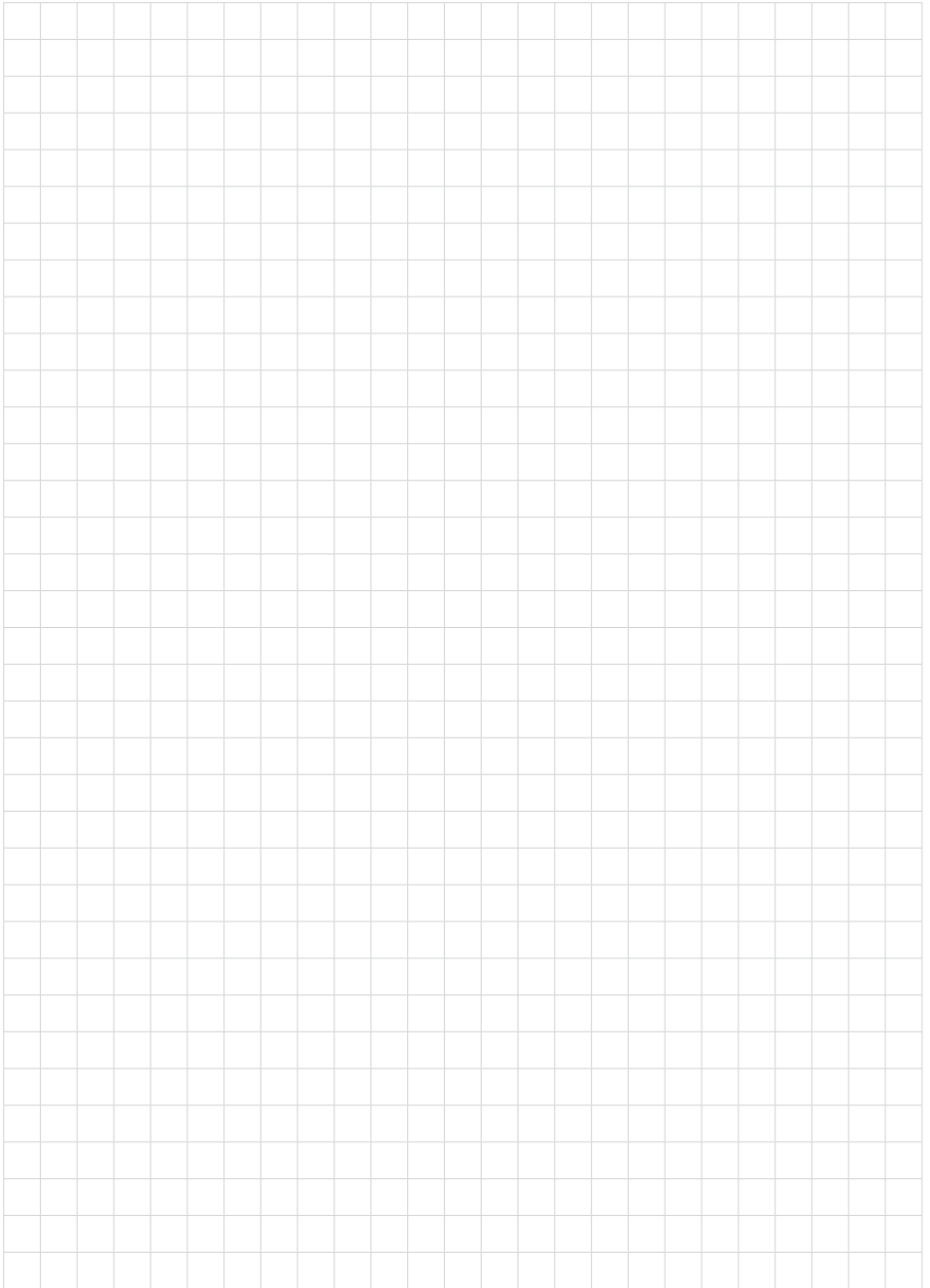

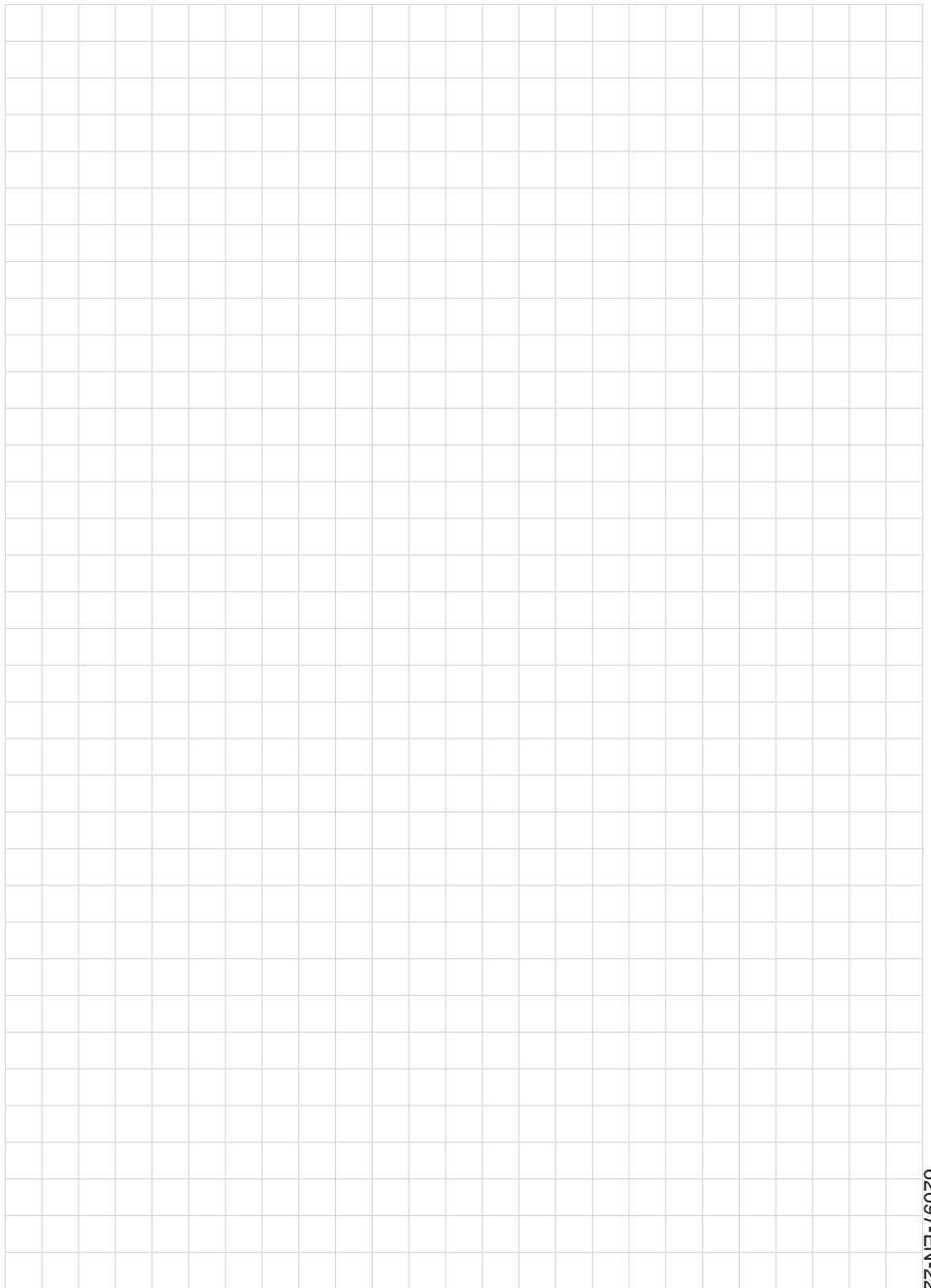

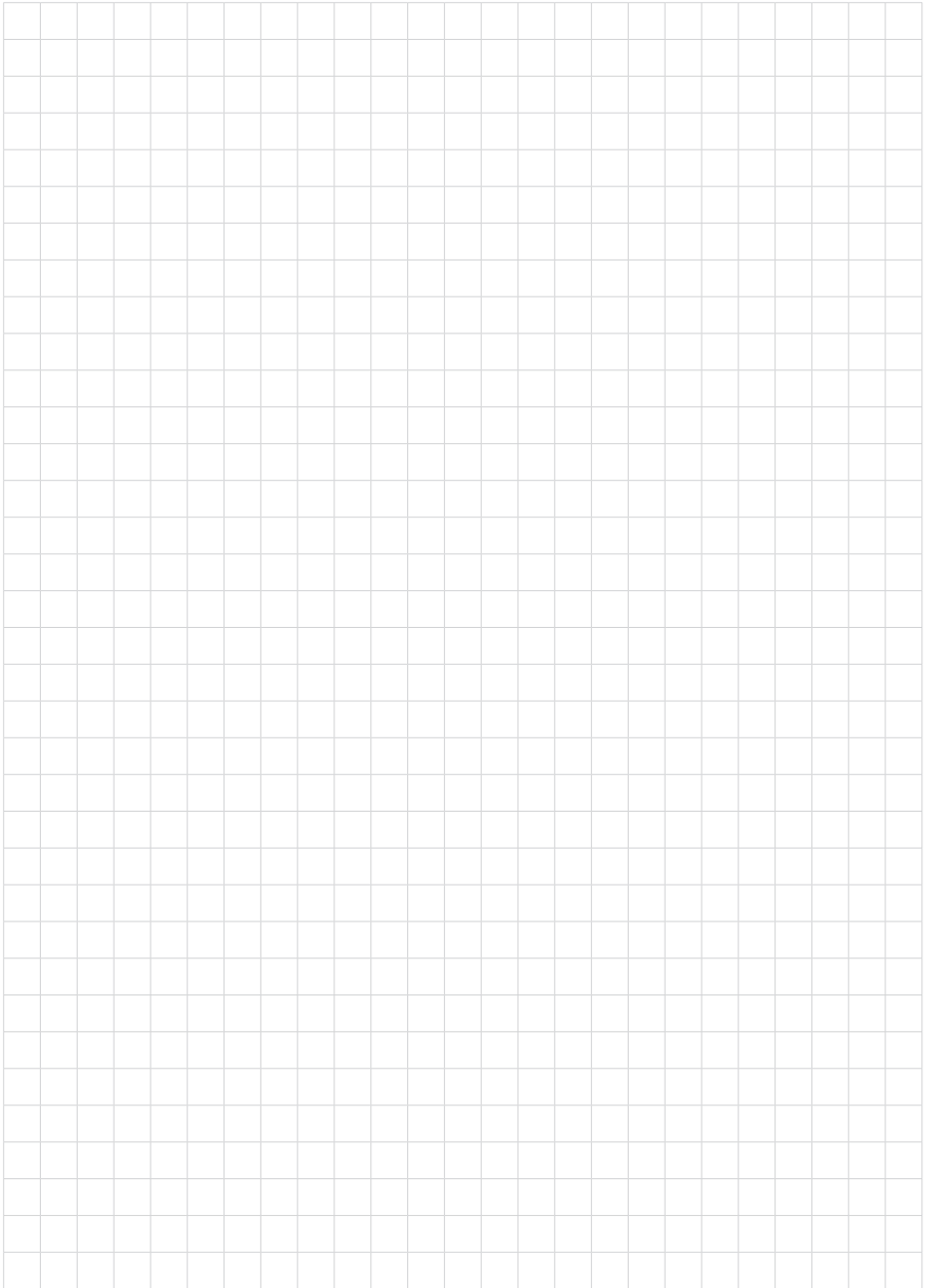

Printing date:

# VEGA

All statements concerning scope of delivery, application, practical use and operating conditions of the sensors and processing systems correspond to the information available at the time of printing.

Subject to change without prior notice

© VEGA Grieshaber KG, Schiltach/Germany 2022



62097-EN-221012

VEGA Grieshaber KG  
Am Hohenstein 113  
77761 Schiltach  
Germany

Phone +49 7836 50-0  
E-mail: [info.de@vega.com](mailto:info.de@vega.com)  
[www.vega.com](http://www.vega.com)