

Operating Instructions

Vibrating level switch for liquids

VEGASWING 51

Transistor (PNP)



Document ID: 40552



VEGA

Contents

1	About this document	3
1.1	Function	3
1.2	Target group	3
1.3	Symbols used	3
2	For your safety	4
2.1	Authorised personnel	4
2.2	Appropriate use	4
2.3	Warning about incorrect use	4
2.4	General safety instructions	4
2.5	Safety label on the instrument	5
2.6	Conformity	5
2.7	Installation and operation in the USA and Canada	5
2.8	Environmental instructions	5
3	Product description	6
3.1	Configuration	6
3.2	Principle of operation	6
3.3	Adjustment	7
3.4	Supplementary cleaning procedures	7
3.5	Packaging, transport and storage	8
4	Mounting	9
4.1	General instructions	9
4.2	Mounting instructions	11
5	Connecting to power supply	13
5.1	Preparing the connection	13
5.2	Wiring plan	14
6	Setup	19
6.1	Indication of the switching status	19
6.2	Simulation	19
6.3	Function table	20
7	Maintenance and fault rectification	21
7.1	Maintenance	21
7.2	Rectify faults	21
7.3	How to proceed if a repair is necessary	22
8	Dismount	23
8.1	Dismounting steps	23
8.2	Disposal	23
9	Supplement	24
9.1	Technical data	24
9.2	Dimensions	28
9.3	Industrial property rights	31
9.4	Trademark	31

1 About this document

1.1 Function

This instruction provides all the information you need for mounting, connection and setup as well as important instructions for maintenance, fault rectification, the exchange of parts and the safety of the user. Please read this information before putting the instrument into operation and keep this manual accessible in the immediate vicinity of the device.

1.2 Target group

This operating instructions manual is directed to trained personnel. The contents of this manual must be made available to the qualified personnel and implemented.

1.3 Symbols used



Document ID

This symbol on the front page of this instruction refers to the Document ID. By entering the Document ID on www.vega.com you will reach the document download.



Information, note, tip: This symbol indicates helpful additional information and tips for successful work.



Note: This symbol indicates notes to prevent failures, malfunctions, damage to devices or plants.



Caution: Non-observance of the information marked with this symbol may result in personal injury.



Warning: Non-observance of the information marked with this symbol may result in serious or fatal personal injury.



Danger: Non-observance of the information marked with this symbol results in serious or fatal personal injury.



Ex applications

This symbol indicates special instructions for Ex applications.



List

The dot set in front indicates a list with no implied sequence.



Sequence of actions

Numbers set in front indicate successive steps in a procedure.



Disposal

This symbol indicates special instructions for disposal.

2 For your safety

2.1 Authorised personnel

All operations described in this documentation must be carried out only by trained, qualified personnel authorised by the plant operator.

During work on and with the device, the required personal protective equipment must always be worn.

2.2 Appropriate use

The VEGASWING 51 is a sensor for point level detection.

You can find detailed information about the area of application in chapter " *Product description*".

Operational reliability is ensured only if the instrument is properly used according to the specifications in the operating instructions manual as well as possible supplementary instructions.

For safety and warranty reasons, any invasive work on the device beyond that described in the operating instructions manual may be carried out only by personnel authorised by the manufacturer. Arbitrary conversions or modifications are explicitly forbidden.

2.3 Warning about incorrect use

Inappropriate or incorrect use of this product can give rise to application-specific hazards, e.g. vessel overflow through incorrect mounting or adjustment. Damage to property and persons or environmental contamination can result. Also, the protective characteristics of the instrument can be impaired.

2.4 General safety instructions

This is a state-of-the-art instrument complying with all prevailing regulations and directives. The instrument must only be operated in a technically flawless and reliable condition. The operator is responsible for the trouble-free operation of the instrument. When measuring aggressive or corrosive media that can cause a dangerous situation if the instrument malfunctions, the operator has to implement suitable measures to make sure the instrument is functioning properly.

The safety instructions in this operating instructions manual, the national installation standards as well as the valid safety regulations and accident prevention rules must be observed by the user.

For safety and warranty reasons, any invasive work on the device beyond that described in the operating instructions manual may be carried out only by personnel authorised by the manufacturer. Arbitrary conversions or modifications are explicitly forbidden. For safety reasons, only the accessory specified by the manufacturer must be used.

To avoid any danger, the safety approval markings and safety tips on the device must also be observed.

2.5 Safety label on the instrument

The safety approval markings and safety tips on the device must be observed.

2.6 Conformity

The device complies with the legal requirements of the applicable country-specific directives or technical regulations. We confirm conformity with the corresponding labelling.

The corresponding conformity declarations can be found on our homepage.

2.7 Installation and operation in the USA and Canada

This information is only valid for USA and Canada. Hence the following text is only available in the English language.

Installations in the US shall comply with the relevant requirements of the National Electrical Code (ANSI/NFPA 70).

Installations in Canada shall comply with the relevant requirements of the Canadian Electrical Code.

2.8 Environmental instructions

Protection of the environment is one of our most important duties. That is why we have introduced an environment management system with the goal of continuously improving company environmental protection. The environment management system is certified according to DIN EN ISO 14001.

Please help us fulfil this obligation by observing the environmental instructions in this manual:

- Chapter "*Packaging, transport and storage*"
- Chapter "*Disposal*"

3 Product description

3.1 Configuration

Scope of delivery

The scope of delivery encompasses:

- VEGASWING 51 point level switch
- Test magnet
- Documentation
 - This operating instructions manual
 - If necessary, certificates

Constituent parts

The VEGASWING 51 consists of the components:

- Housing with electronics
- Process fitting with tuning fork



Fig. 1: VEGASWING 51

Type label

The type label contains the most important data for identification and use of the instrument:

- Article number
- Serial number
- Technical data
- Article numbers, documentation

With the serial number, you can access the delivery data of the instrument via "www.vega.com", "Search". You can find the serial number on the inside of the instrument as well as on the type label on the outside.

3.2 Principle of operation

Application area

VEGASWING 51 is a point level sensor with tuning fork for point level detection.

It is designed for industrial use in all areas of process technology and can be used in liquids.

Typical applications are overflow and dry run protection. With a tuning fork of only 38 mm length, VEGASWING 51 can be also mounted e.g. in pipelines from DN 25. The small tuning fork allows use in vessels, tanks and pipes. Thanks to its simple and robust measuring system,

VEGASWING 51 is virtually unaffected by the chemical and physical properties of the liquid.

It functions even under difficult conditions such as turbulence, air bubbles, foam generation, buildup, strong external vibration or changing products.

Function monitoring

The electronics module of VEGASWING 51 continuously monitors the following criteria via frequency evaluation:

- Strong corrosion or damage on the tuning fork
- Loss of vibration
- Line break to the piezo drive

If a malfunction is detected or in case of voltage supply, the electronics takes on a defined switching status, i.e. the output is open (safe state).

Functional principle

The tuning fork is piezoelectrically energised and vibrates at its mechanical resonance frequency of approx. 1100 Hz. When the tuning fork is submerged in the product, the frequency changes. This change is detected by the integrated electronics module and converted into a switching command.

Voltage supply

VEGASWING 51 is a compact instrument, i.e. it can be operated without external evaluation system. The integrated electronics evaluates the level signal and outputs a switching signal. With this switching signal, a connected device can be operated directly (e.g. a warning system, a pump etc.).

The data for power supply are specified in chapter " *Technical data*".

3.3 Adjustment

The switching status of VEGASWING 51 can be checked when the housing is closed (signal lamp). Products with a density $> 0.7 \text{ g/cm}^3$ (0.025 lbs/in^3) or ordered optionally with a density $> 0.5 \text{ g/cm}^3$ (0.018 lbs/in^3) can be detected.

3.4 Supplementary cleaning procedures

3.4.1 Oil, grease and silicone-free

The VEGASWING 51 is also available in the version " *Oil, grease and silicone-free*". These instruments have passed through a special cleaning procedure to remove oil, grease and paint-wetting impairment substances (PWIS).

The cleaning is carried out on all wetted parts as well as on surfaces accessible from outside. To keep the purity level, the instruments are immediately packed in plastic foil after the cleaning process. The purity level remains as long as the instrument is kept in the closed original packaging.

**Caution:**

The VEGASWING 51 in this version must only be used in oxygen applications.

3.5 Packaging, transport and storage

Packaging

Your instrument was protected by packaging during transport. Its capacity to handle normal loads during transport is assured by a test based on ISO 4180.

The packaging of standard instruments consists of environment-friendly, recyclable cardboard. For special versions, PE foam or PE foil is also used. Dispose of the packaging material via specialised recycling companies.

Transport

Transport must be carried out in due consideration of the notes on the transport packaging. Nonobservance of these instructions can cause damage to the device.

Transport inspection

The delivery must be checked for completeness and possible transit damage immediately at receipt. Ascertained transit damage or concealed defects must be appropriately dealt with.

Storage

Up to the time of installation, the packages must be left closed and stored according to the orientation and storage markings on the outside.

Unless otherwise indicated, the packages must be stored only under the following conditions:

- Not in the open
- Dry and dust free
- Not exposed to corrosive media
- Protected against solar radiation
- Avoiding mechanical shock and vibration

Storage and transport temperature

- Storage and transport temperature see chapter " *Supplement - Technical data - Ambient conditions*"
- Relative moisture 20 ... 85 %

4 Mounting

4.1 General instructions

Process conditions



Note:

For safety reasons, the instrument must only be operated within the permissible process conditions. You can find detailed information on the process conditions in chapter " *Technical data*" of the operating instructions or on the type label.

Hence make sure before mounting that all parts of the instrument exposed to the process are suitable for the existing process conditions.

These are mainly:

- Active measuring component
- Process fitting
- Process seal

Process conditions in particular are:

- Process pressure
- Process temperature
- Chemical properties of the medium
- Abrasion and mechanical influences

Suitability for the ambient conditions

The instrument is suitable for standard and extended ambient conditions acc. to DIN/EN/IEC/ANSI/ISA/UL/CSA 61010-1. It can be used indoors as well as outdoors.

Switching point

In general, VEGASWING 51 can be installed in any position. The instrument only has to be mounted in such a way that the tuning fork is at the height of the desired switching point.

Keep in mind that the switching point can vary dependent on the installation position.

The switching point refers to the medium water (1 g/cm³/0.036 lbs/in³). Please keep in mind that the switching point of the instrument shifts when the medium has a density differing from water.

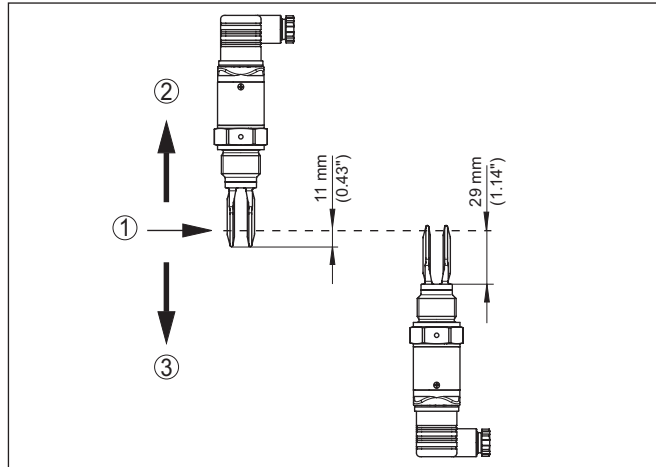

Fig. 2: Vertical mounting

- 1 Switching point in water
- 2 Switching point with lower density
- 3 Switching point with higher density

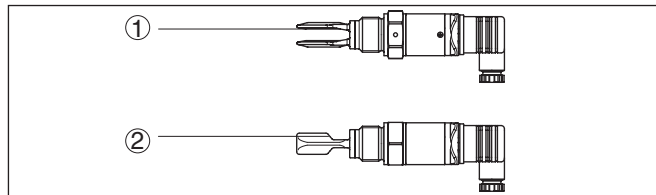

Fig. 3: Horizontal mounting

- 1 Switching point
- 2 Switching point (recommended mounting position, particularly for adhesive products)

Moisture

Use the recommended cables (see chapter "Connecting to power supply") and tighten the cable gland.

You can give your VEGASWING 51 additional protection against moisture penetration by leading the connection cable downward in front of the cable gland. Rain and condensation water can thus drain off. This applies mainly to outdoor mounting as well as installation in areas where high humidity is expected (e.g. through cleaning processes) or on cooled or heated vessels.

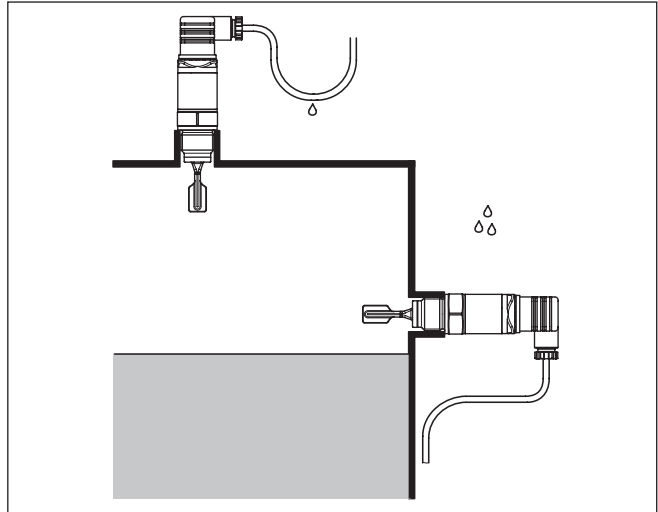

Fig. 4: Measures against moisture ingress

Transport

Do not hold VEGASWING 51 on the tuning fork.

Pressure/Vacuum

The process fitting must be sealed if there is gauge or low pressure in the vessel. Before use, check if the sealing material is resistant against the measured product and the process temperature.

The max. permissible pressure is specified in chapter " *Technical data*" or on the type label of the sensor.

Handling

The vibrating level switch is a measuring instrument and must be treated accordingly. Bending the vibrating element will destroy the instrument.



Warning:

The housing must not be used to screw the instrument in! Applying tightening force can damage internal parts of the housing.

Use the hexagon above the thread for screwing in.

4.2 Mounting instructions

Welded socket

For threaded versions of VEGASWING 51 in combination with a mounting boss with O-ring in front and welding marking.

VEGASWING 51 with thread sizes 1/2", 3/4" and 1" have a defined thread. This means that every VEGASWING 51 is in the same position after being screwed in. Remove therefore the supplied flat seal from the thread of VEGASWING 51. This flat seal is not required when using a welded socket with front-flush seal.

Before welding, unscrew VEGASWING 51 and remove the rubber ring from the welded socket.

The welded socket is provided with a marking (notch). With horizontal mounting, weld the socket with the notch facing upward or downward; in pipelines (DN 25 to DN 50) aligned with the direction of flow.

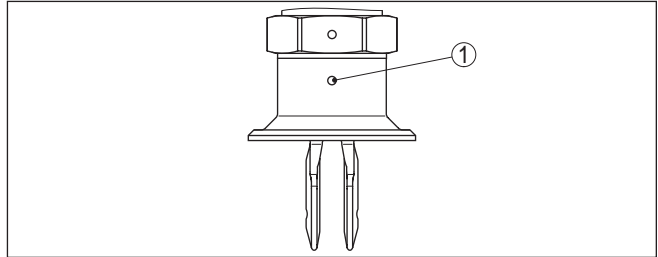

Fig. 5: Marking on the welded socket

1 Marking

Adhesive products

In case of horizontal mounting in adhesive and viscous media, the surfaces of the tuning fork should be vertical in order to reduce build-up on the tuning fork. The position of the tuning fork is indicated by a hexagon of VEGASWING 51. With this, you can check the position of the tuning fork when screwing it in. When the hexagon touches the seal, the thread can still be turned by approx. half a turn. This is sufficient to reach the recommended installation position.

In adhesive and viscous media, the surfaces of the tuning fork should protrude into the vessel to avoid buildup. Therefore nozzles for flanges and mountings bosses should not exceed a certain length.

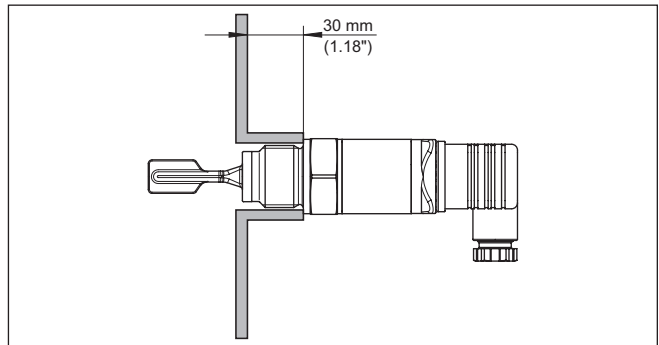

Fig. 6: Adhesive products

Inflowing medium

If VEGASWING 51 is mounted in the filling stream, unwanted false measurement signals can be generated. For this reason, mount VEGASWING 51 at a position in the vessel where no disturbances, e.g. from filling openings, agitators, etc., can occur.

Product flow

To make sure the tuning fork of VEGASWING 51 generates as little resistance as possible to product flow, mount the sensor so that the surfaces are parallel to the product movement.

5 Connecting to power supply

5.1 Preparing the connection

Note safety instructions

Always keep in mind the following safety instructions:



Warning:

Connect only in the complete absence of line voltage.

- The electrical connection must only be carried out by trained, qualified personnel authorised by the plant operator.
- Always switch off power supply, before connecting or disconnecting the instrument.

Connection cable

The instrument is connected with standard three-wire cable without shielding. If electromagnetic interference is expected which is above the test values of EN 61326 for industrial areas, shielded cable should be used.

Use cable with round cross section. Depending on the plug connection, you have to select the outer diameter of the cable respectively so that the seal effect of the cable gland is ensured.

- Valve plug ISO 4400, \varnothing 4.5 ... 7 mm
- Valve plug ISO 4400 with IDC crimping technology, \varnothing 5.5 ... 8 mm

Cable glands

Use cable with a round wire cross section and tighten the cable gland.

Make sure that the cable used has the required temperature resistance and fire safety for max. occurring ambient temperature

When mounting outdoors, on cooled vessels or in moist areas in which cleaning is made with steam or high pressure, the sealing of the cable gland is very important.

5.2 Wiring plan

Housing overview

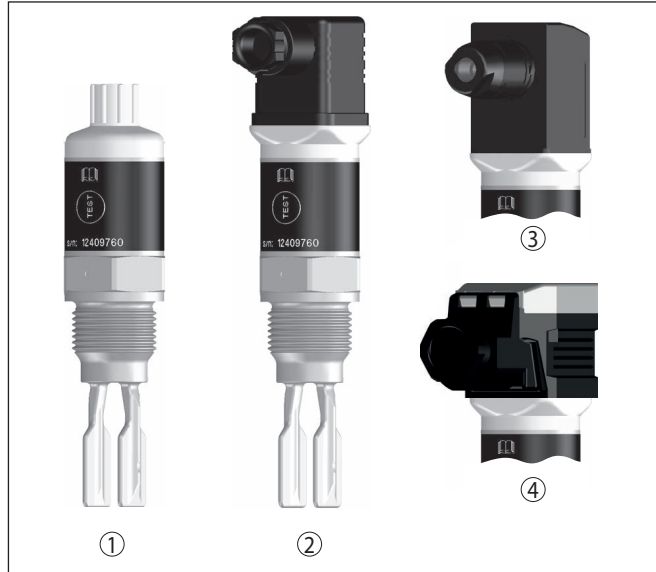

Fig. 7: Overview of the connection versions

- 1 M12 x 1 plug connection
- 2 Valve plug ISO 4400
- 3 Valve plug ISO 4400 with IDC method of termination
- 4 Valve plug ISO 4400 with hinged cover

Plug versions

M12 x 1 plug connection

This plug connection requires a prefabricated cable with plug. Depending on the version, protection IP66/IP67 or IP68 (0.2 bar).

Valve plug ISO 4400

For this plug version, standard cable with round wire cross-section can be used. Cable diameter 4.5 ... 7 mm, protection IP65.

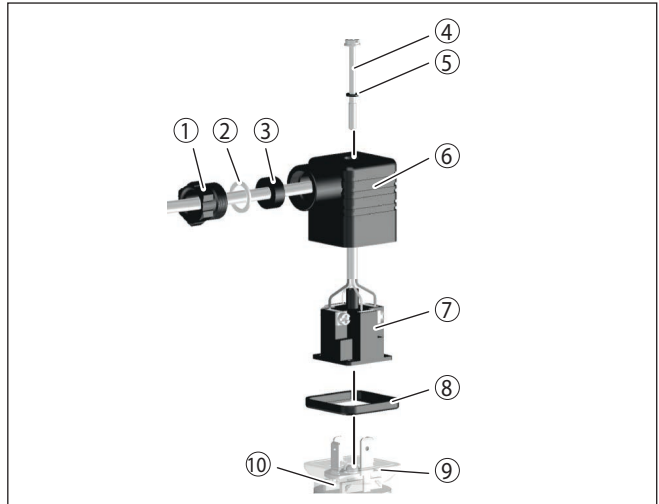

Fig. 8: Connection, valve plug ISO 4400

- 1 Pressure screw
- 2 Pressure disc
- 3 Seal ring
- 4 Fixing screw
- 5 Seal washer
- 6 Plug housing
- 7 Plug insert
- 8 Profile seal
- 9 Control lamp
- 10 VEGASWING 51

Valve plug ISO 4400 with IDC method of termination

For this plug version you can use standard cable with round wire cross-section. The inner conductors do not have to be stripped. The plug connects the conductors automatically when screwing in. Cable diameter 5.5 ... 8 mm, protection IP67.

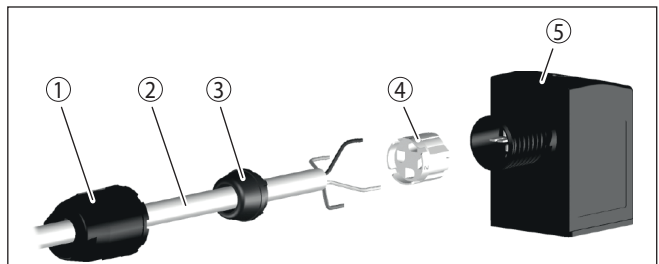

Fig. 9: Connection, valve plug ISO 4400 with IDC crimping technology

- 1 Compression nut
- 2 Cable
- 3 Seal ring
- 4 Terminal insert
- 5 Plug housing

Valve plug ISO 4400 with hinged cover

For this plug version, standard cable with round wire cross-section can be used. Cable diameter 4.5 ... 7 mm, protection IP65.

1. Loosen the screw in the cover of the plug connector
2. Open the cover and remove it
3. Press the plug insert downwards
4. Loosen the screws of the strain relief and cable entry

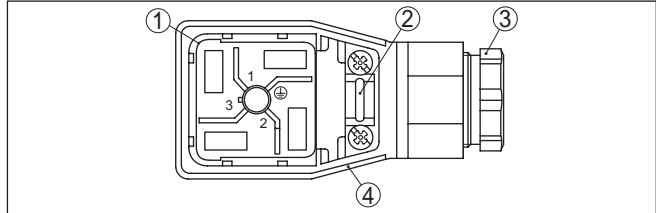

Fig. 10: Loosen the plug insert

- 1 Plug insert
- 2 Strain relief
- 3 Cable gland
- 4 Plug housing

5. Remove approx. 5 cm of the cable mantle, strip approx. 1 cm insulation from the individual wires
6. Lead the cable through the cable gland into the plug housing
7. Connect the wire ends to the screw terminals according to the wiring plan

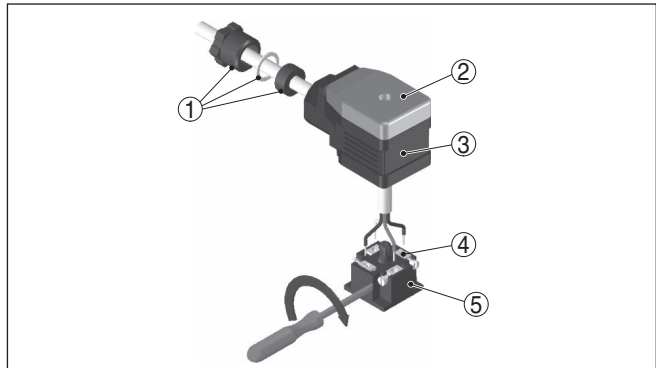

Fig. 11: Connection to the screw terminals

- 1 Cable gland
- 2 Cover
- 3 Plug housing
- 4 Plug insert
- 5 Plug seal

8. Snap the plug insert into the plug housing and insert the sensor seal



Information:

Note the correct arrangement, see illustration

9. Tighten the screws on the strain relief and cable entry
10. Hook in the cover and push onto the plug connection, tighten cover screw
11. Plug the plug insert with seal to VEGASWING 51 and tighten the screw

Transistor output

For connection to binary inputs of a PLC.

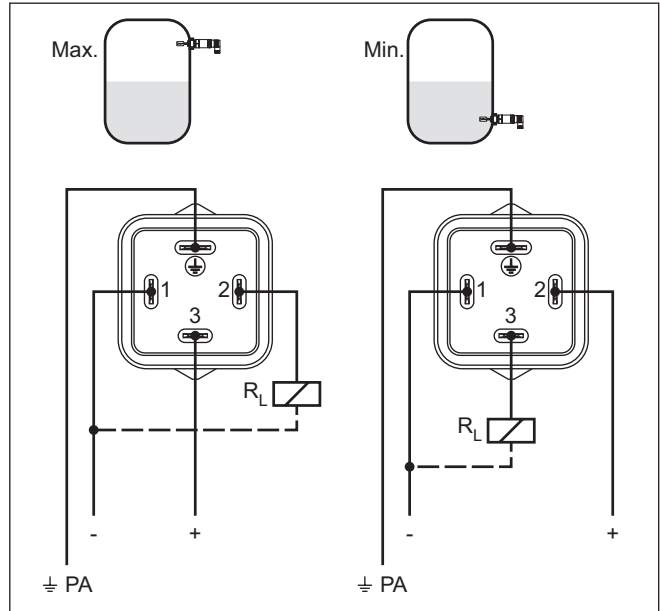

Fig. 12: Wiring plan, Transistor output with valve plug ISO 4400

PA Potential equalisation

R_L Load resistance (contactor, relay, etc.)

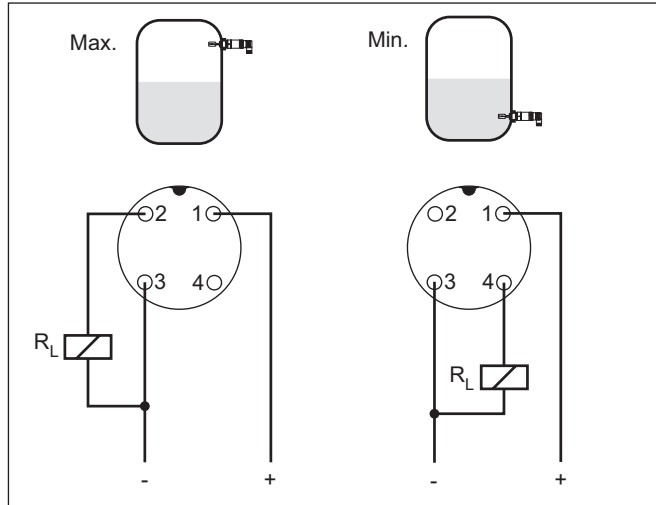

Fig. 13: Wiring plan (housing), transistor output with M12 x 1 plug connection

- 1 Brown
 - 2 White
 - 3 Blue
 - 4 Black
- R_L Load resistance (contactor, relay, etc.)

6 Setup

6.1 Indication of the switching status

The switching status of the electronics can be checked via the signal lamps (LEDs) integrated in the upper part of the housing.

The signal lamps have the following meaning:

- Green lights - voltage supply connected
- Yellow lights - vibrating element covered
- Red lights briefly - function test during instrument start (for approx. 1 s)
- Red lights - shortcircuit or overload in the load circuit (sensor output high-impedance)
- Red flashes - Error on the vibrating element or the electronics (sensor output high impedance)

6.2 Simulation

The VEGASWING 51 has an integrated function for simulation of the output signal which can be activated magnetically. Please proceed as follows:

- Hold the test magnet (accessory) against the circle symbol with the label "TEST" on the instrument housing

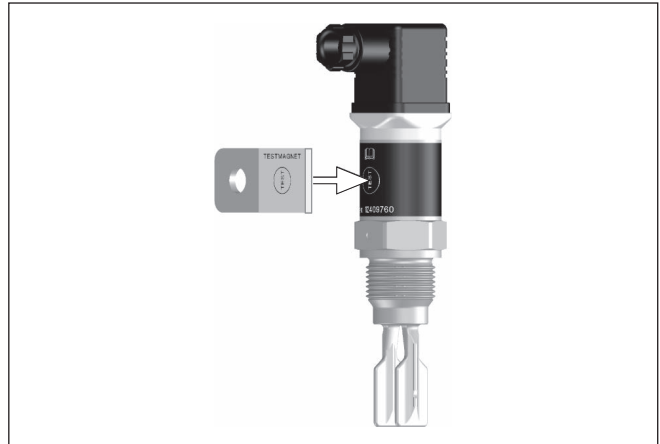

Fig. 14: Simulation of the output signal

The test magnet changes the current switching state of the device for the duration of the application. You can check the change on the control lamp. Note that the downstream devices are activated during the simulation.

If VEGASWING 51 does not switch over after several tests with the test magnet, you have to check the plug connection and the connection cable and try it again. If there is no switching function, the electronics will be defective. In this case you have to exchange the electronics or return the instrument to our repair department.

**Caution:**

It is absolutely necessary that you remove the test magnet from the instrument housing after the simulation.

6.3 Function table

The following table provides an overview of the switching conditions depending on the set mode and the level.

	Level	Switching status	Control lamp Yellow - coverage	Control lamp Green - voltage indication	Control lamp Red - fault signal
Max. mode of operation		closed	○		○
Max. mode of operation		open			○
Min. mode of operation		closed			○
Min. mode of operation		open	○		○
Fault	any	open	any		

7 Maintenance and fault rectification

7.1 Maintenance

Maintenance

If the device is used properly, no special maintenance is required in normal operation.

Cleaning

The cleaning helps that the type label and markings on the instrument are visible.

Take note of the following:

- Use only cleaning agents which do not corrode the housings, type label and seals
- Use only cleaning methods corresponding to the housing protection rating

7.2 Rectify faults

Reaction when malfunction occurs

The operator of the system is responsible for taking suitable measures to rectify faults.

Causes of malfunction

The device offers maximum reliability. Nevertheless, faults can occur during operation. These may be caused by the following, e.g.:

- Sensor
- Process
- Voltage supply
- Signal processing

Fault rectification

The first measure to take is to check the output signal. In many cases, the causes can be determined this way and the faults quickly rectified.

24 hour service hotline

Should these measures not be successful, please call in urgent cases the VEGA service hotline under the phone no. **+49 1805 858550**.

The hotline is manned 7 days a week round-the-clock. Since we offer this service worldwide, the support is only available in the English language. The service is free, only standard call charges are incurred.

Checking the switching signal

Error	Cause	Rectification
Green signal lamp off	Voltage supply interrupted.	Check the voltage supply and the cable connection
	Electronics defective	Exchange the instrument or send it in for repair
Red signal lamp lights (switching output high-impedance)	Error with the electrical connection	Connect the instrument according to the wiring plan
	Shortcircuit or overload	Check the electrical connection

Error	Cause	Rectification
Red signal lamp flashes (switching output high-impedance)	Vibrating frequency out of specification	Check the vibrating element on build-up and remove it
	Buildup on the vibrating element	Check the vibrating element and the sensor if there is buildup and remove it
	Vibrating element damaged	Check if the vibrating element is damaged or extremely corroded

Reaction after fault rectification

Depending on the reason for the fault and the measures taken, the steps described in chapter "Setup" must be carried out again or must be checked for plausibility and completeness.

7.3 How to proceed if a repair is necessary

You can find an instrument return form as well as detailed information about the procedure in the download area of our homepage. By doing this you help us carry out the repair quickly and without having to call back for needed information.

In case of repair, proceed as follows:

- Print and fill out one form per instrument
- Clean the instrument and pack it damage-proof
- Attach the completed form and, if need be, also a safety data sheet outside on the packaging
- Ask the agency serving you to get the address for the return shipment. You can find the agency on our homepage.

8 Dismount

8.1 Dismounting steps

**Warning:**

Before dismantling, be aware of dangerous process conditions such as e.g. pressure in the vessel, high temperatures, corrosive or toxic products etc.

Take note of chapters "*Mounting*" and "*Connecting to voltage supply*" and carry out the listed steps in reverse order.

8.2 Disposal



Pass the instrument on to a specialised recycling company and do not use the municipal collecting points.

Remove any batteries in advance, if they can be removed from the device, and dispose of them separately.

If personal data is stored on the old device to be disposed of, delete it before disposal.

If you have no way to dispose of the old instrument properly, please contact us concerning return and disposal.

9 Supplement

9.1 Technical data

Note for approved instruments

The technical data in the respective safety instructions which are included in delivery are valid for approved instruments (e.g. with Ex approval). These data can differ from the data listed herein, for example regarding the process conditions or the voltage supply.

All approval documents can be downloaded from our homepage.

General data

Material 316L corresponds to 1.4404 or 1.4435

Materials, wetted parts

- Tuning fork	316L
- Process seal (in the scope of delivery)	- Thread
Klingersil C-4400	- Hygienic connection with compression nut
FKM, EPDM	- Process fittings
316L	

Materials, non-wetted parts

- Housing	316L and plastic PEI
- Cable gland	PA, stainless steel, brass
- Sealing, cable gland	NBR
- Blind plug, cable gland	PA

M12 x 1 plug connector

- Contact support	PA
- Contacts	CuZn, nickel layer and 0.8 µm gold-plated
- Plug seal	FKM

Plug connector according to ISO 4400

- Contact, housing plug	PA
- Lid screw	StSt
- Contact surface	Sn
- Plug seal	Silicone

Weight approx. 250 g (9 oz)

Process fittings

- Pipe thread, cylindrical (DIN 3852-A)	G $\frac{1}{2}$, G $\frac{3}{4}$, G1, R1
- Pipe thread, conical (ASME B1.20.1)	$\frac{1}{2}$ NPT, $\frac{3}{4}$ NPT, 1 NPT

hygienic fittings

- Clamp (DIN 32676, ISO 2852)	1", 1 $\frac{1}{2}$ ", 2"
- Slotted nut	DN 25 PN 40, DN 40 PN 40, DN 50 PN 25
- SMS	DN 38 PN 6
- Hygienic fitting	F 40 PN 25

Max. torque - process fitting

- Thread G $\frac{1}{2}$, $\frac{1}{2}$ NPT 50 Nm (37 lbf ft)
- Thread G $\frac{3}{4}$, $\frac{3}{4}$ NPT 75 Nm (55 lbf ft)
- Thread G1, 1 NPT 100 Nm (73 lbf ft)

Surface quality

- Standard $R_a < 3.2 \mu\text{m}$ (1.26⁻⁴ in)
- Hygienic version $R_a < 0.8 \mu\text{m}$ (3.15⁻⁵ in)

Measurement accuracy

- Hysteresis approx. 2 mm (0.08 in) with vertical mounting
- Switching delay approx. 500 ms (on/off)
Can be ordered as an option: 0.5 ... 60 s
- Measuring frequency approx. 1100 Hz

Ambient conditions

- Ambient temperature on the housing -40 ... +70 °C (-40 ... +158 °F)
- Storage and transport temperature -40 ... +80 °C (-40 ... +176 °F)

Process conditions

- Process pressure -1 ... 64 bar/-100 ... 6400 kPa (-14.5 ... 928 psig)
- Process temperature - Standard -40 ... +100 °C (-40 ... +212 °F)

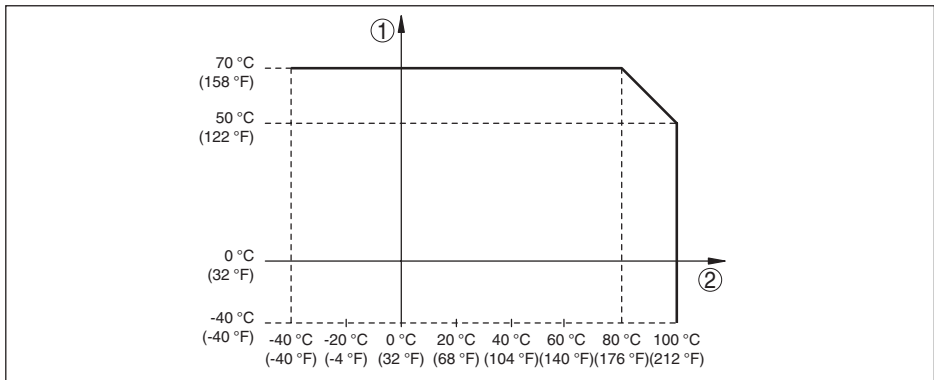

Fig. 15: Dependency ambient temperature to process temperature

- 1 Ambient temperature in °C (°F)
- 2 Process temperature in °C (°F)

Process temperature - High temperature -40 ... +150 °C (-40 ... +302 °F)
version (option)

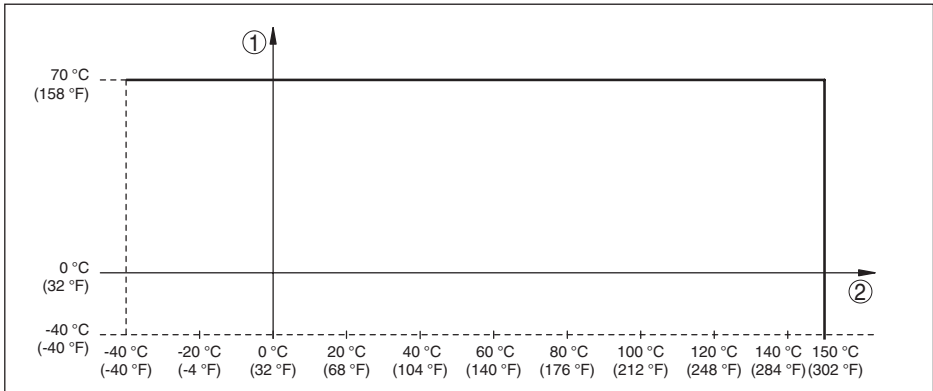

Fig. 16: Dependency ambient temperature to process temperature

- 1 Ambient temperature in °C (°F)
2 Process temperature in °C (°F)

Viscosity - dynamic	0.1 ... 10000 mPa s
Flow velocity	max. 6 m/s (with a viscosity of 10000 mPa s)
Density	
– Standard sensitivity	0.7 ... 2.5 g/cm ³ (0.025 ... 0.09 lbs/in ³)
– High sensitivity (can be ordered optionally)	0.5 ... 2.5 g/cm ³ (0.018 ... 0.09 lbs/in ³)

Adjustment

Plug connections	Specification see "Connecting to voltage supply"
Signal lamps (LEDs)	
– Green	Voltage supply on
– Yellow	Vibrating element covered
– Red	Fault

Output variable

Output	Transistor output PNP
Load current	max. 250 mA (output, permanently short-circuit proof)
Voltage loss	< 3 V
Switching voltage	< 34 V DC
Blocking current	< 10 μA
Mode	
– Min./Max.	Changeover by electronic connection
– Max.	Overflow protection
– Min.	Dry run protection

Voltage supply

Operating voltage	9.6 ... 35 V DC
-------------------	-----------------

Power consumption max. 0.5 W

Electromechanical data

M12 x 1 plug connector

– Cable Fixed connected to the plug

Valve plug ISO 4400

– Wire cross-section 1.5 mm² (0.06 in²)
 – Outer cable diameter 4.5 ... 7 mm (0.18 ... 0.28 in)

Valve plug ISO 4400 with hinged cover

– Wire cross-section 1.5 mm² (0.06 in²)
 – Outer cable diameter 4.5 ... 7 mm (0.18 ... 0.28 in)

Valve plug ISO 4400 with IDC method of termination

– Version 4-pin according to ISO 4400
 – Wire cross-section 0.5 ... 1 mm² (AWG 20 ... AWG 17)
 – Strand diameter > 0.1 mm (0.004 in)
 – Wire diameter 1.6 ... 2 mm² (0.06 ... 0.08 in²)
 – Outer cable diameter 5.5 ... 8 mm (0.22 ... 0.31 in)
 – Connection frequency 10 x (on the same cross-section)

Electrical protective measures

Protection rating

– Valve plug ISO 4400 IP65 acc. to IEC 60529, Type 3SX acc. to NEMA
 – Valve plug ISO 4400 with IDC method of termination IP67 acc. to IEC 60529, Type 4X acc. to NEMA
 – Valve plug ISO 4400 with hinged cover IP65 acc. to IEC 60529, Type 4X acc. to NEMA
 – M12 x 1 plug connection IP66/IP67 acc. to IEC 60529, Type 4X acc. to NEMA or IP68 (0.2 bar) acc. to IEC 60529, Type 6P acc. to NEMA

Overvoltage category

The feeding power supply unit can be connected to networks of overvoltage category III.

Protection class

II

Approvals

Instruments with approvals can have different technical specifications depending on the version.

For that reason the associated approval documents of these instruments have to be carefully noted. They are part of the delivery or can be downloaded by entering the serial number of your instrument into the search field under www.vega.com as well as in the general download area.

9.2 Dimensions

VEGASWING 51, standard version - thread

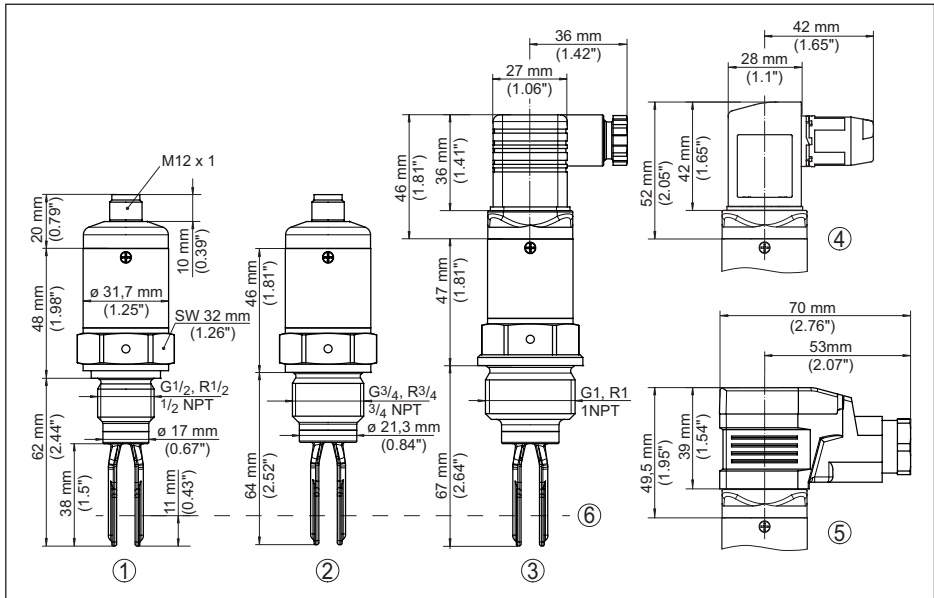

Fig. 17: VEGASWING 51, standard version - threaded fittings

- 1 Thread G $\frac{1}{2}$ (DIN ISO 228/1), $\frac{1}{2}$ NPT, M12 x 1 plug ¹⁾
- 2 Thread G $\frac{3}{4}$ (DIN ISO 228/1), $\frac{3}{4}$ NPT, M12 x 1 plug
- 3 Thread G1 (DIN ISO 228/1), 1 NPT, valve plug ISO 4400
- 4 Valve plug ISO 4400 with IDC method of termination
- 5 Valve plug ISO 4400 with hinged cover
- 6 Switching point

¹⁾ Keep in mind that the total length is extended by the plug connection.

VEGASWING 51, high temperature version

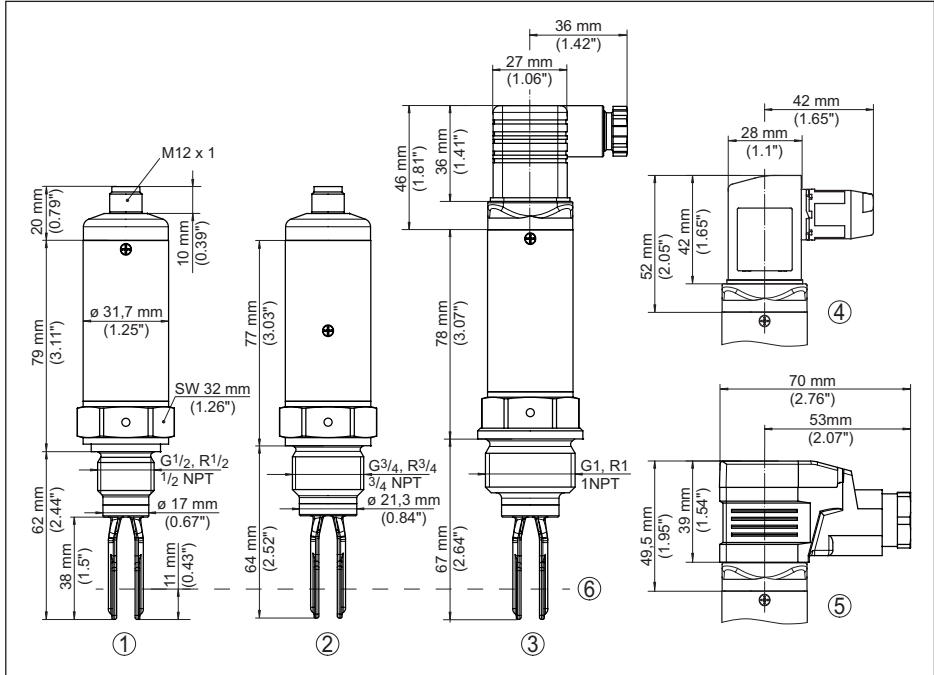

Fig. 18: VEGASWING 51, high temperature versions - threaded fittings

- 1 Thread G $\frac{1}{2}$ (DIN ISO 228/1), $\frac{1}{2}$ NPT, M12 x 1 plug ²⁾
- 2 Thread G $\frac{3}{4}$ (DIN ISO 228/1), $\frac{3}{4}$ NPT, M12 x 1 plug
- 3 Thread G1 (DIN ISO 228/1), 1 NPT, valve plug ISO 4400
- 4 Valve plug ISO 4400 with IDC method of termination
- 5 Valve plug ISO 4400 with hinged cover
- 6 Switching point

²⁾ Keep in mind that the total length is extended by the plug connection.

VEGASWING 51, hygienic versions

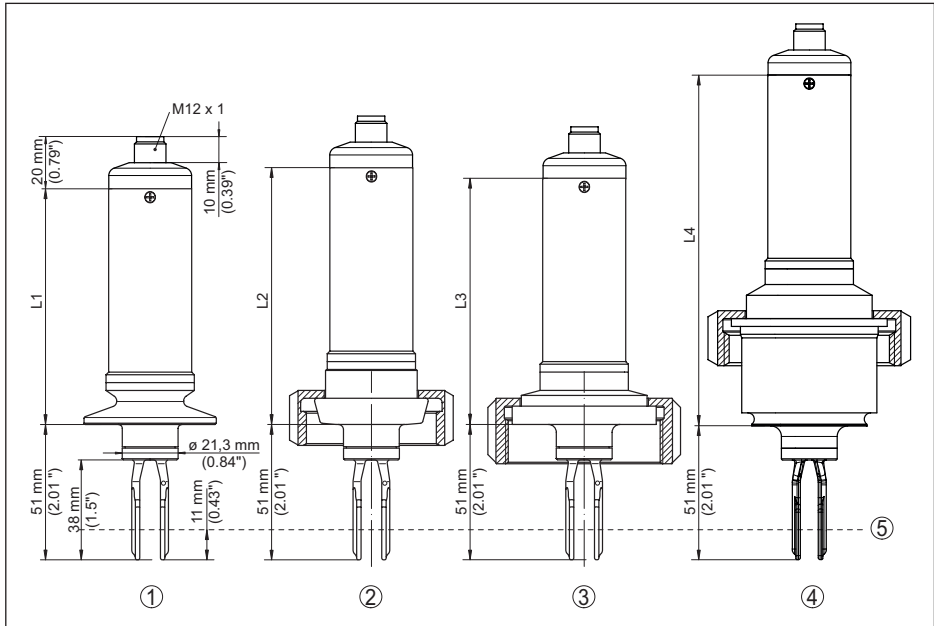

Fig. 19: VEGASWING 51, hygienic versions - hygienic fittings

- 1 Clamp, M12 x 1 plug³⁾
- 2 Slotted nut, M12 x 1 plug
- 3 SMS 1145, M12 x 1 plug
- 4 Hygienic fitting with compression nut, M12 x 1 plug
- 5 Switching point
- L1 Length with Clamp
 - Clamp 1": 90 mm (3.54 in)
 - Clamp 1½": 90 mm (3.54 in)
 - Clamp 2": 89 mm (3.50 in)
- L2 Length with slotted nut
 - DN 25 PN 40: 98 mm (3.86 in)
 - DN 40 PN 40: 103 mm (4.06 in)
 - DN 50 PN 25: 104 mm (4.09 in)
- L3 Length with SMS
 - DN 38 PN 6: 94 mm (3.70 in)
- L4 Length with aseptic fitting
 - 134 mm (5.28 in)

³⁾ Keep in mind that the total length is extended by the plug connection.

9.3 Industrial property rights

VEGA product lines are global protected by industrial property rights. Further information see www.vega.com.

VEGA Produktfamilien sind weltweit geschützt durch gewerbliche Schutzrechte.

Nähere Informationen unter www.vega.com.

Les lignes de produits VEGA sont globalement protégées par des droits de propriété intellectuelle. Pour plus d'informations, on pourra se référer au site www.vega.com.

VEGA lineas de productos están protegidas por los derechos en el campo de la propiedad industrial. Para mayor información revise la pagina web www.vega.com.

Линии продукции фирмы ВЕГА защищаются по всему миру правами на интеллектуальную собственность. Дальнейшую информацию смотрите на сайте www.vega.com.

VEGA系列产品在全球享有知识产权保护。

进一步信息请参见网站 < www.vega.com。

9.4 Trademark

All the brands as well as trade and company names used are property of their lawful proprietor/originator.

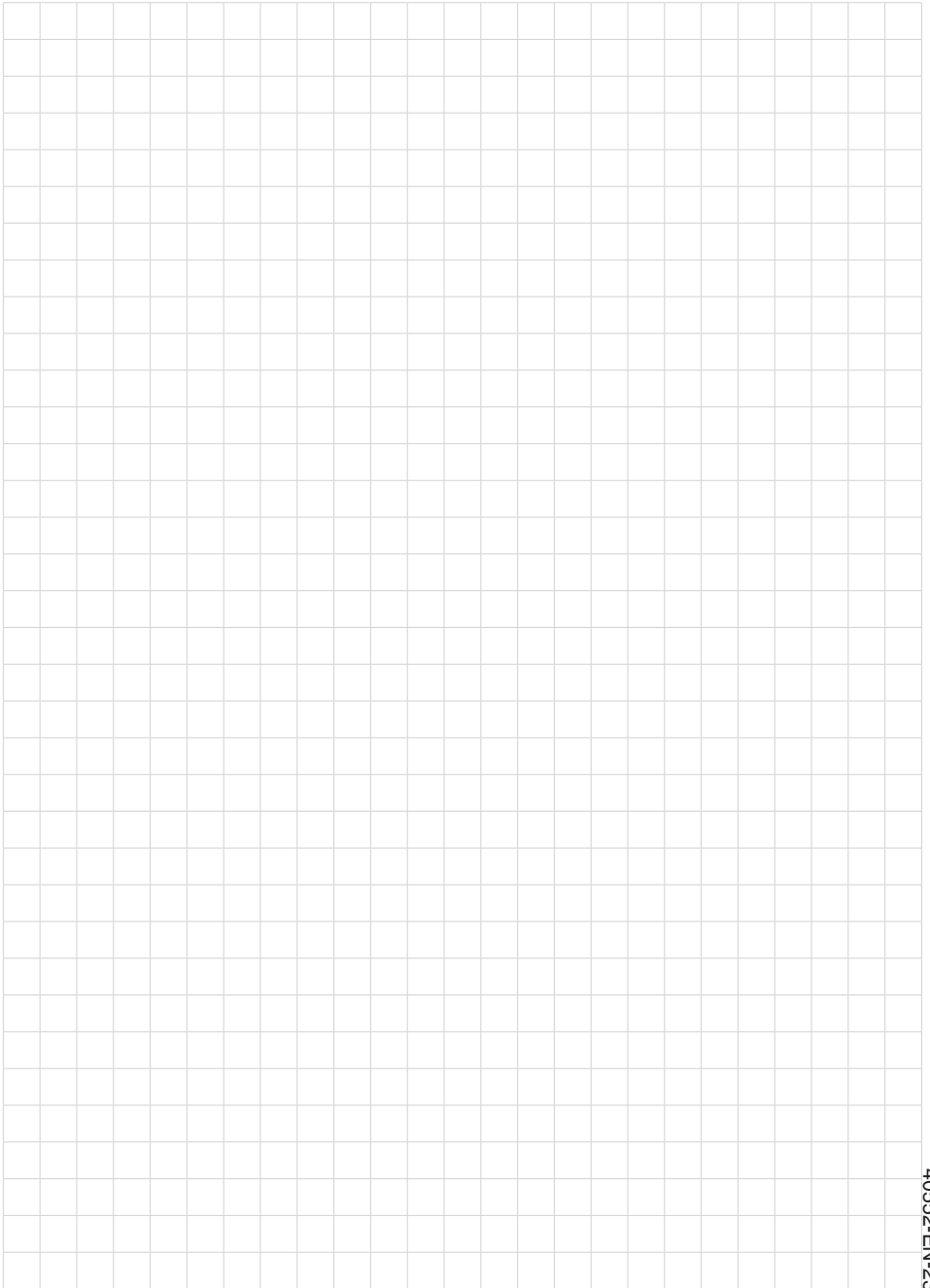

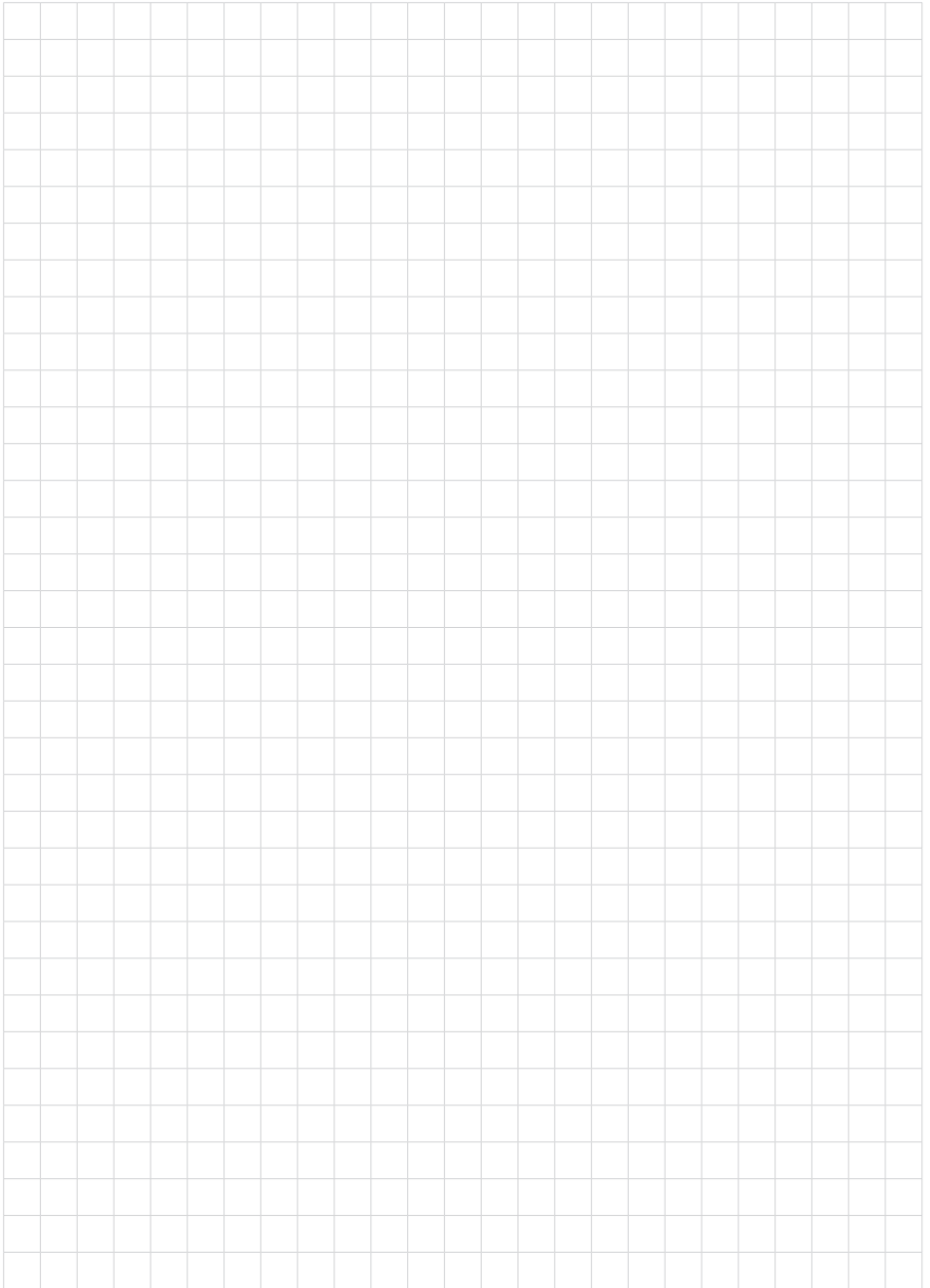

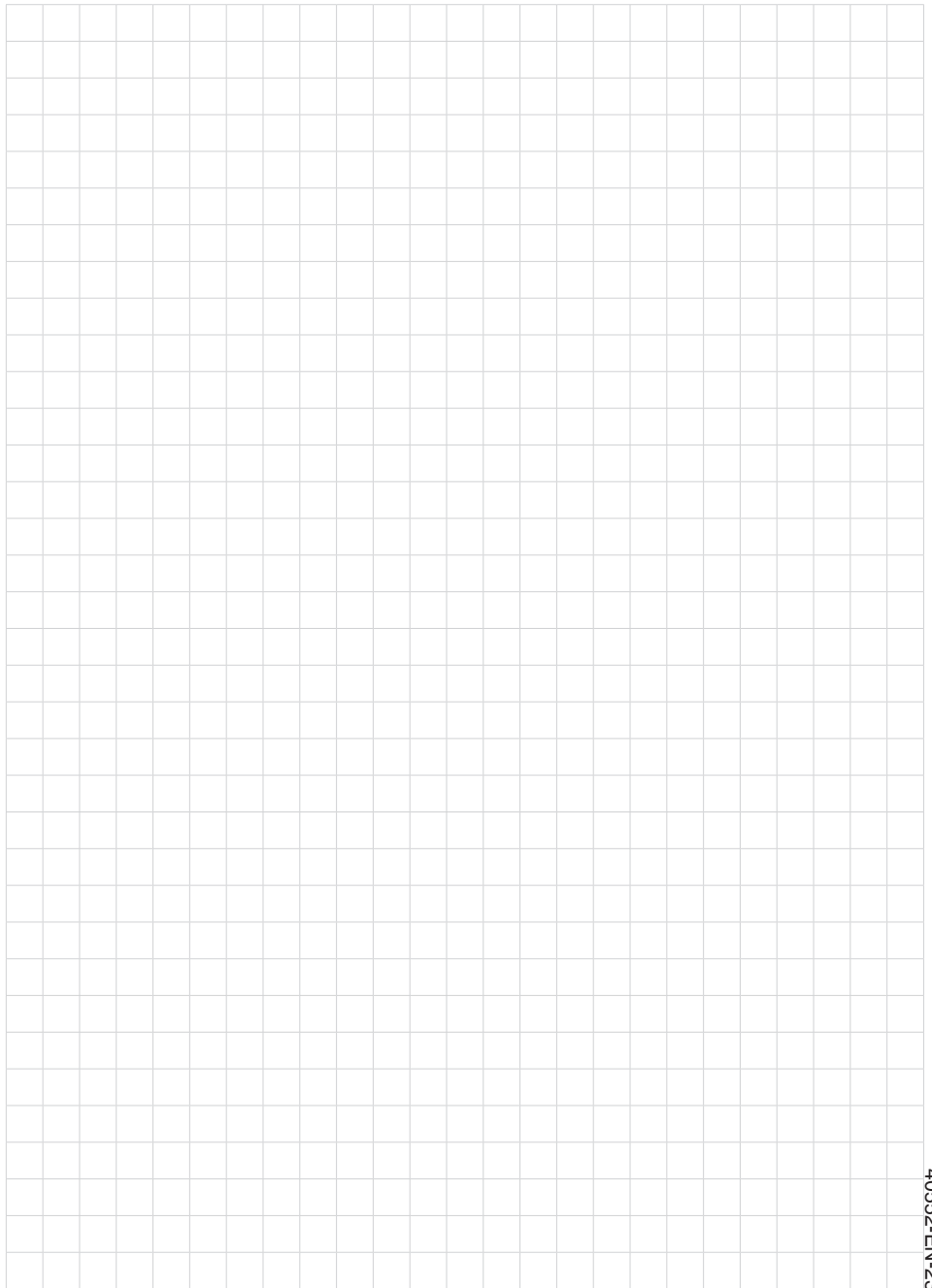

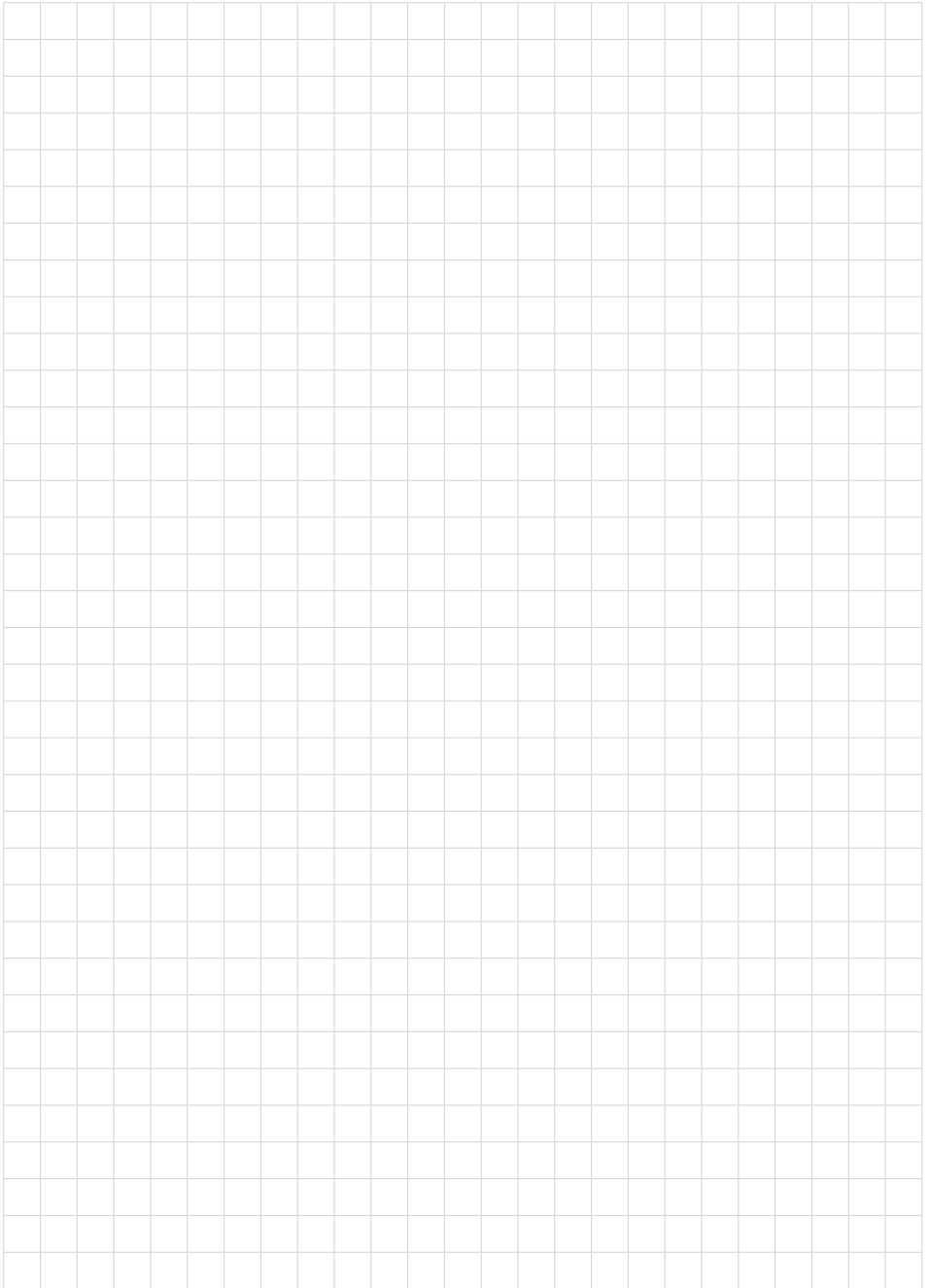

Printing date:

VEGA

All statements concerning scope of delivery, application, practical use and operating conditions of the sensors and processing systems correspond to the information available at the time of printing.

Subject to change without prior notice

© VEGA Grieshaber KG, Schiltach/Germany 2023



40552-EN-230208

VEGA Grieshaber KG
Am Hohenstein 113
77761 Schiltach
Germany

Phone +49 7836 50-0
E-mail: info.de@vega.com
www.vega.com