

INSTRUCTION MANUAL

Tri-axial Groundborne Vibration Meter

VM-56



3-20-41 Higashimotomachi, Kokubunji, Tokyo 185-8533, Japan

<https://www.rion.co.jp/english/>

Organization of this manual

This manual describes the features, operation and other aspects of the Tri-axial Groundborne Vibration Meter VM-56. If the unit is used together with other equipment to configure a measurement system, consult the documentation of all other components as well. Pages iii and following contain important information about safety. Be sure to read and observe these in full.

This manual contains the following sections.

Outline

Gives basic information on the configuration and features of the unit, and contains a block diagram.

Controls and features

Briefly identifies and explains all parts of the unit.

Preparations

Describes power supply and pre-use checks, installation, connections, key settings, and other steps.

Reading the Display

Explains symbols and other information shown on the display of the unit.

Measurement

Describes the steps for measurement.

Comparator

Explain the operation of the comparator.

Store operation

Explains how to store measurement data.

Card capacity and store time

Lists the data store time corresponding to the SD memory card capacity, etc.

Output Connectors

Explains the input and output connectors of the unit.

Default Settings

Lists the factory default settings of the unit.

Setup Files

Explains how to start up the unit using settings saved in a setup file.

Optional Accessories

Explains how to use the optional extension cord with the unit.

Serial Interface

Describes how to use the internal serial interface for connection to a computer, to control measurement parameters and export measurement data.

Reference Information

Lists the battery life and INPUT connector.

Specifications

Lists the technical specifications of the unit.

* All company names and product names mentioned in this manual are trademarks or registered trademarks of their respective owners.

FOR SAFETY

In this manual, important safety instructions are specially marked as shown below. To prevent the risk of death or injury to persons and severe damage to the unit or peripheral equipment, make sure that all instructions are fully understood and observed.

⚠ WARNING	Disregarding instructions printed here incurs the risk of death or severe injury to persons.
•	

⚠ Caution	Disregarding instructions printed here incurs the risk of injury to persons and/or damage to peripheral equipment.
•	

Important	Disregarding instructions printed here incurs the risk of damage to the product.
•	

	Indicates a prohibited action. This information is given to prevent accidents and ensure safe use of the unit.
•	



Note	Additional information about using the unit. (These notes do not directly affect safety.)
•	

Precautions

- Operate the unit only as described in this manual.
- Take care not to drop the unit, and protect it from shocks and vibrations.
- Take care not to drop the vibration meter, and protect it from shocks.
- Ambient conditions for operation of the unit are as follows: temperature range -20°C to $+50^{\circ}\text{C}$, relative humidity up to 90%RH.
Protect the unit from water, dust, extreme temperatures, humidity, and direct sunlight during storage. Also keep the unit away from air with high salt or sulphur content, gases, and stored chemicals during storage and use.
- Always turn the unit off after use. Remove the batteries from the unit if it is not to be used for a long time. Otherwise battery fluid may leak, posing a risk of corrosion and damage.
- If you notice any sign of a problem during use, disconnect the AC adapter, remove the battery, and contact your supplier or an authorized service station.
- The power cord included with the unit as shipped from the factory is a 100 V AC cord for domestic use in Japan, which is compliant with Japanese laws and electrical safety standards. Do not use the factory-supplied power cord outside Japan or with any voltage other than 100 V AC. Otherwise, Rion Corporation cannot guarantee the safety of the equipment. Use a power cord that is compliant with the laws and electrical safety standards of the usage location.
- When disconnecting cables, always grasp the plug and do not pull the cable.
- Store this unit in the right place in the supplied storage case.
- Clean the unit only by wiping it with a soft, dry cloth or, when necessary, with a cloth lightly moistened with water. Do not use any solvents, cleaning alcohol or chemical cleaning agents.
- Do not tap the LCD panel or other surfaces of the unit with a pointed object such as a pen, pencil, screwdriver, etc.
- Take care that no conductive objects such as wire, metal scraps, conductive plastics etc. can get into the unit.
- Do not try to disassemble or alter the unit. In case of an apparent malfunction, do not attempt any repairs. Note the condition of the unit clearly and contact the supplier.

- Never format optional program cards such as the VX-56RT and VX-56WR with SD memory card formatting software (such as SD Formatter, etc.). Otherwise the program data on the card will be erased and the respective functions can no longer be used. Restoration of the erased program is not warranted.
- In order to maintain the “water and dust resistant performance” of the unit, observe the following precautions.
 - Make sure that the battery compartment lid, the side cover and the top cover of the unit are firmly closed.
 - Do not open the battery compartment lid while the unit is wet.
 - Do not leave the unit in a wet state. Always wipe off any moisture and properly dry the unit.
 - Have the unit regularly checked and calibrated, to ensure continued “water and dust resistant performance”.
 - We recommend to have the packing inside the case, the side cover and the top cover replaced regularly (fare-paying service). The cycle of replacing the side cover and top cover is two years. The cycle of replacing the waterproof parts of the case and the battery lid part is 5 years. If the cycle of replacing the waterproof parts have passed, the “water and dust resistant performance” of the unit will no longer be guaranteed. Regarding replacement of the packing, the side cover and the top cover, please contact your supplier.
- The life of the backup battery for the internal clock of the unit is limited. You should have the battery replaced about once every five years. Regarding replacement of the battery, please contact your supplier.
- Please note that this product is warranted up to the product purchase price against defects in material.
- Dispose of the unit and of batteries only according to national and local regulations at the place of use.
- If a failure of the PV-83D level gauge has led to a leak, do not touch the gauge fluid.
- If the fluid has come into contact with eyes, immediately flush with plenty of clean water and consult an ophthalmologist.
- If the fluid has come into contact with skin, take off the surrounding clothing and wash the exposed skin with plenty of water and soap.

Precautions for opening the case

Before opening the case and removing any equipment, place the case on sturdy, flat table or on the floor. Then open the case fully as shown below.

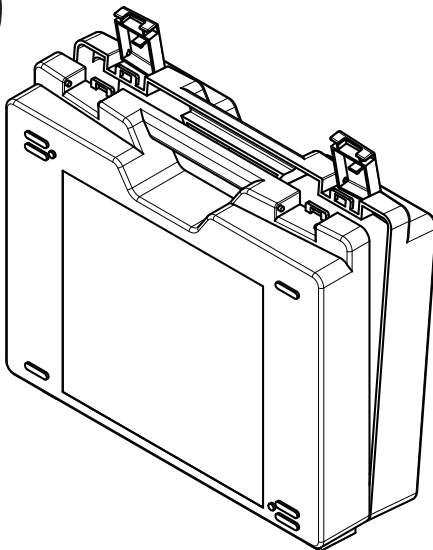
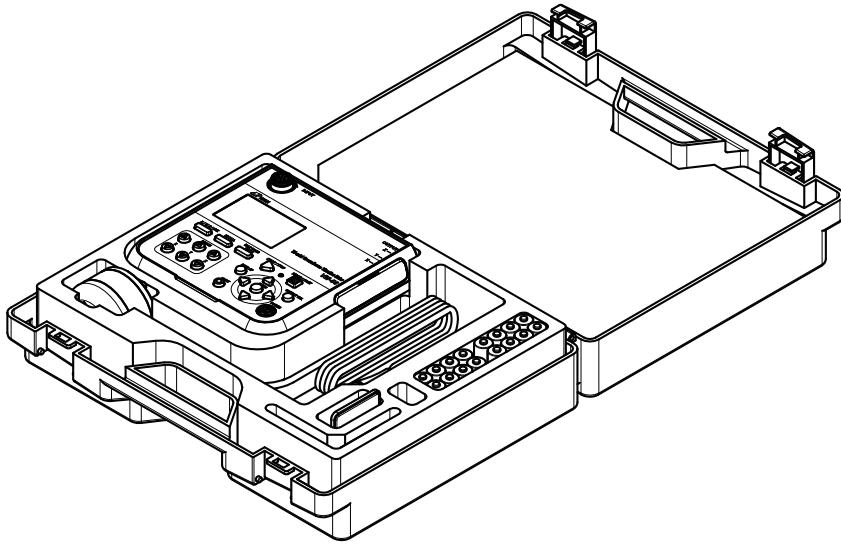

Never open the case while it is standing upright. Otherwise equipment may fall out, possibly causing damage and accidents.

This product can be used in any areas including residential areas.

To conform to the EU requirement of the Directive on Waste Electrical and Electronic Equipment, the symbol mark on the right is shown on the instrument.



Contents

FOR SAFETY.....	iii
Precautions for opening the case	vi
Outline	1
Controls and features	3
Front view.....	3
Right side view	7
Top view	9
Bottom view	10
Vibration Pickup and extension cord	11
Preparations	12
Power.....	12
Power on/off	16
Vibration pickup placement and connection	18
SD memory card and program cards.....	23
Connection to a data recorder (DA-21), and other device	24
Connection to a computer	25
Setting the date and time	26
Measurement in a dark location	28
Eco setting (Power-saving mode)	30
Calibration	32
Reading the Display	34
Measurement screen display	34
Measurement screen	39
Measurement screen (3 channels display).....	39
Max Hold display screen.....	40
Processed data display screen	41
Time-level display screen.....	43
Indicator messages	44
Menu list screen.....	45
System.....	46
Store.....	49

Display / I/O.....	55
Save.....	57
Option	58
Measure.....	59
Recall.....	61
Measurement.....	65
Manual mode.....	65
Auto mode	65
Operation if Level Trigger is on.....	66
Timer Auto mode.....	67
Procedure example of the measurement.....	68
Comparator	69
Store operation.....	71
About the store data format.....	71
About SD memory cards.....	72
Formatting an SD memory card.....	73
Screen hard copy	74
Card capacity and store time	75
Using Auto store	75
When performing waveform recording	76
Output Connectors	77
OUTPUT connector.....	77
Default Settings.....	80
Setup Files	81
Resume function.....	81
Loading a start up file at startup.....	81
Restoring default settings (factory default settings).....	82
Using setup files.....	83
Setting a start up file.....	85
Optional Accessories.....	86
Extension cord	86

DIN plate VP-54D /	
L-bracket (for wall mounting)VP-54L installation.....	88
Serial Interface.....	91
RS-232C	91
USB	94
Connection to a computer	102
Disconnection from the computer	103
Communication cutoff	104
Rated values	105
Command	106
Command list	109
Command description	114
Command example	151
Reference Information.....	153
Battery life.....	153
INPUT connector	154
Calibration example using an exciter	154
Wm, Wb, Wd Frequency response characteristics (typical characteristics)	155
Non-weighting frequency response characteristics (typical characteristics)	156
PV-83D frequency response characteristics.....	156
VM-56+PV-83D Frequency response characteristics.....	157
Velocity frequency response characteristics	158
Displacement frequency response characteristics	162
DIN plate frequency response characteristics.....	163
L-bracket frequency response characteristics	163
Peak Vector Sum (PVS)	164
Specifications	165

Outline

The VM-56 is the Tri-axial Groundborne Vibration Meter which is made according to DIN 45669-1 and ISO 8041 for measuring ground-borne vibrations in order to evaluate the effects on persons and/or on structures. Peak particle velocity (PPV), vibration dose value (VDV), and other values (e.g. displacement) which are calculated simultaneously can be stored to SD memory card at user-specified intervals, and can also be obtained via communication interface (USB, RS-232C).

The VM-56 consists of the main unit and Vibration Pickup PV-83D. Hence the system processes 3 channels of vibration signal, and allows real-time analysis of each channels. Waveform recording as PCM format WAVE files on SD memory card will be available if the WR program option is installed, and recorded WAVE files make it easy to analyze later on a computer. The main unit has separate X, Y and Z outputs of analog signal for connecting to other devices (e.g. frequency analyzer), and it's possible to check or analyze the vibration signal on site.

In consideration of environment, size AA nickel metal hydride (Ni-MH) rechargeable batteries can be used to help reduce the amount of battery waste. The unit can be connected the external power supply for a long time measurement.

Features

- PPV, VDV and other values can be calculated simultaneously
- Tri-axial data series can be stored in CSV file
- Program option: Waveform recording, 1/3 octave real-time analysis
- Visibility good LCD on site
- SD/SDHC card (up to 32 GB) available for a long term measurement
- USB/RS-232C communication interface (same as NL-42 series)
- Rechargeable batteries (Ni-MH) available
- Vibration monitoring using comparator function
- Unification of operability with NL-42 series

Block diagram

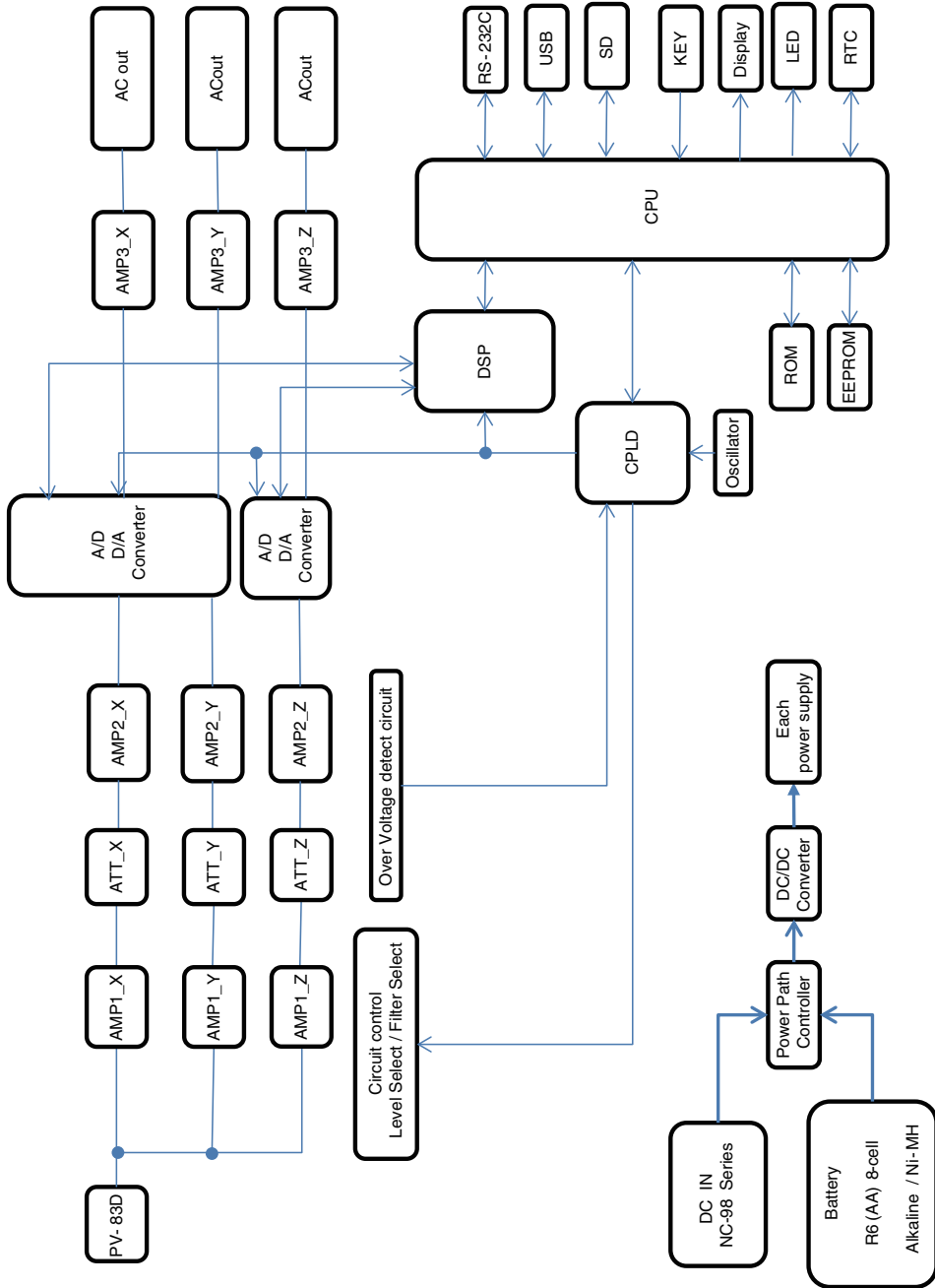

Controls and features

Front view

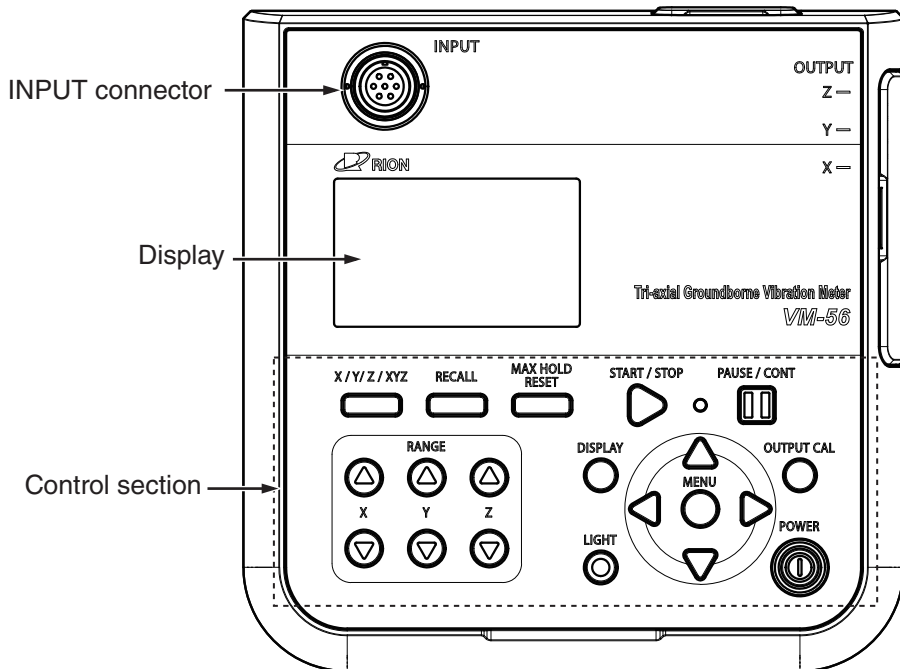

INPUT connector

The Vibration Pickup PV-83D is to be connected here. If the vibration pickup is to be installed at a greater distance, optional extension cord can also be used.

Display

The display of the unit is a backlight LCD panel. It shows the measured acceleration value as a numeric indication, as a bar graph and as a time-level graph. It also indicates the operation status of the unit and shows measurement parameters as well as warning indications and other information.

Control section

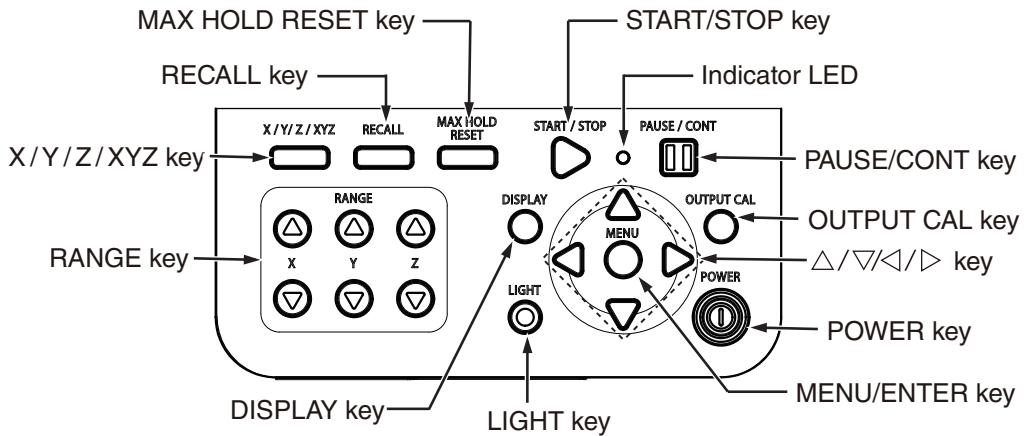

RANGE keys

These keys control the level range for the X, Y, Z axis.

The Δ key switches the range up, and the ∇ key switches the range down.

The following two settings are available: [0.0001 to 1], [0.001 to 10]

X / Y / Z / XYZ key

Switches the vibration axis to be shown on the display.

With each push of the key, the display cycles through the settings in the order $X \rightarrow Y \rightarrow Z \rightarrow XYZ \rightarrow X$ etc.

RECALL key

Transition from measurement screen to recall screen.

MAX HOLD RESET key

Resets the value of the max hold function.

START / STOP key

Serves to start / stop the measurement (store).

Indicator LED

Lights/flashes in red or blue to indicate the operation or status of the unit.

PAUSE/CONT key

Press the key to pause measurement (processing), and press the key again to resume measurement (processing).

During pause in manual processing, the indicator LED flashes in blue.

Note
The PAUSE key does not function while the store mode is Auto or Timer Auto.

OUTPUT CAL key

This key serves for level matching between the unit and peripheral equipment.

△/▽/◀/▶ keys

These four keys serve for selecting and setting items on menu screens.

POWER key

Turns power to the unit on and off. The key must be held down for at least 2 seconds to take effect.

MENU/ENTER key

Press this key to make or finalize the setting of an item in a menu or any other setting.

When the key is pressed at the measurement screen, the menu list screen comes up.

LIGHT key

This key turns on the display backlight, for easier reading in a dark location. Press the key again to turn the backlight off.

When the automatic light out function was selected from the menu, the backlight will turn itself off automatically after the preset time (see page 28).

Also press this key when you want to check the measurement settings in power-saving standby condition (see page 52).

DISPLAY key

This key switches measurement screen display.

Each push of the key cycles through the settings in the following order:
Measurement screen → Max Hold screen → Processed data screen →
Time-level screen → Measurement screen

Key lock

Pressing the ◀ and ▶ keys together activates the key lock. A lock symbol appears in the bottom left corner of the display (see page 34), and the operation keys except for the LIGHT key are disabled.

If a key other than the LIGHT key is pressed, a key lock indication appears.

Pressing the ◀ and ▶ keys together once more cancels the key lock.

To turn the unit off, you must first cancel the key lock and then hold down the POWER key.

The key lock does not function on the menu list screen and calibration screen.

Right side view

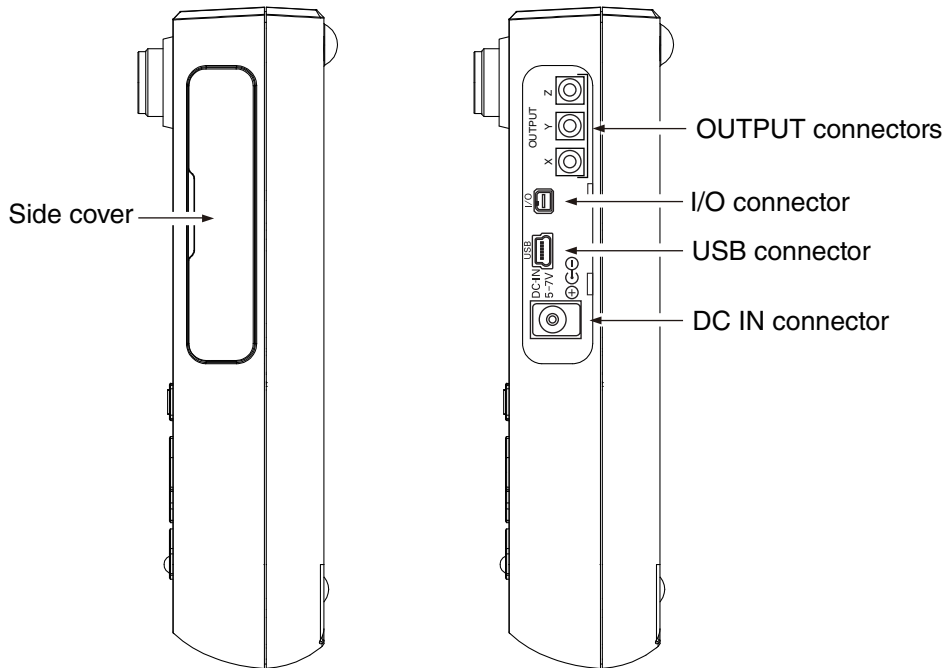

Side cover

This cover protects the connectors on the right side during transport or storage. Removing the cover gives access to the connectors shown above.

Important

To keep the water and dust resistant performance, close tightly the side cover of the unit.

OUTPUT connectors

These are Pin connectors which carry the output signal for the X, Y, and Z axis.

An AC signal corresponding to frequency weighting is output here.

I/O connector

Serves for RS-232C connection.

USB connector (mini B)

Serves for connection to a computer.

DC IN connector

The optional AC adapter NC-98 series can be connected here for powering the unit from an AC outlet (100 V to 240 V AC).

Important
To prevent the risk of damage, do not use any AC adapter and battery pack other than the specified type.

Top view

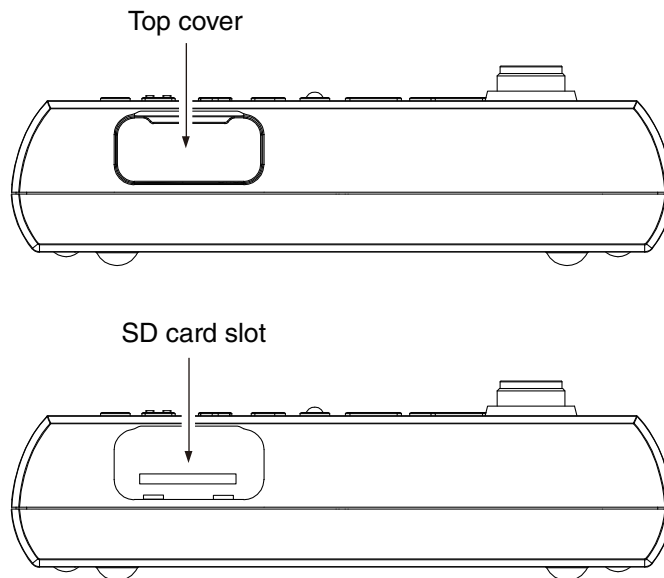

Top cover

This cover protects the connectors on the top during transport or storage. Removing the cover gives access to the connectors shown above.

Important
To keep the water and dust resistant performance, close tightly the top cover of the unit.

SD card slot

The SD memory card can be inserted in this slot.

Bottom view

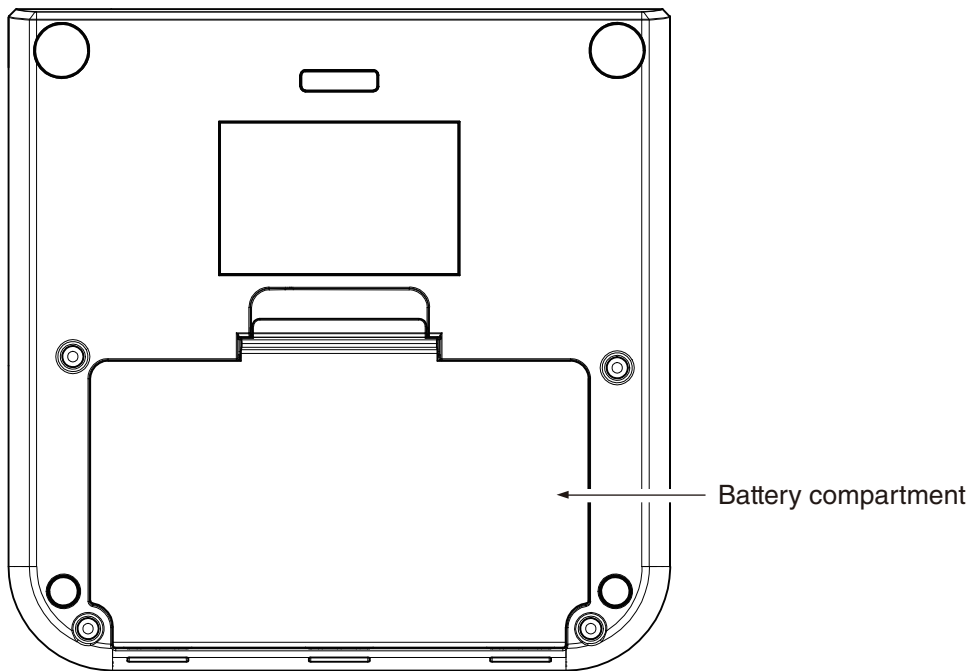

Battery compartment

Eight batteries (IEC LR, size AA) are inserted here. The [power-on mode] switch is in the battery compartment (see page 17).

Vibration Pickup and extension cord

For measurement, the Vibration Pickup PV-83D is required.

Connect the Vibration Pickup PV-83D connector directly to the main unit INPUT connector. For more information, see the section on Vibration pickup placement and connection in “Preparations” on page 18.

This vibration pickup measures acceleration.

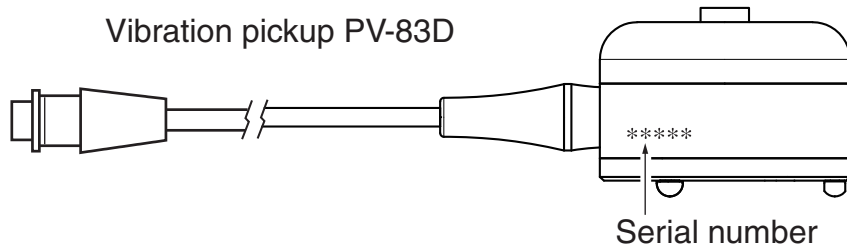

Preparations

Power

The unit can be powered by eight IEC LR6, HR6, size AA batteries (alkaline, rechargeable nickel metal-hydride), and the optional AC adapter NC-98 Series. Rechargeable nickel metal-hydride batteries can be used, but the unit does not have a facility for charging the batteries.

WARNING

If the unit is heated during use or the unit produces smoke or smell of burning, immediately remove the batteries from the unit or disconnect the AC adapter plug from the outlet, and then contact your supplier.

Note

When the AC adapter is connected, the unit will be powered from the adapter, also when batteries are inserted. (The AC adapter has priority.)

In case of a power failure or other interruption of AC power, the unit will automatically switch to battery power and continue operation.

When the unit is operated on only AC adapter, the file auto close function and auto shutdown function will not be executed. We recommend that new batteries be set in the unit.

When using the AC adapter NC-98 series, the unit responds to the momentary stop up to 50 ms.

Inserting the batteries

1. Remove the battery compartment lid as shown below.
2. Insert eight IEC LR6, size AA batteries, paying attention to the polarity as indicated in the compartment.
3. Replace the cover.

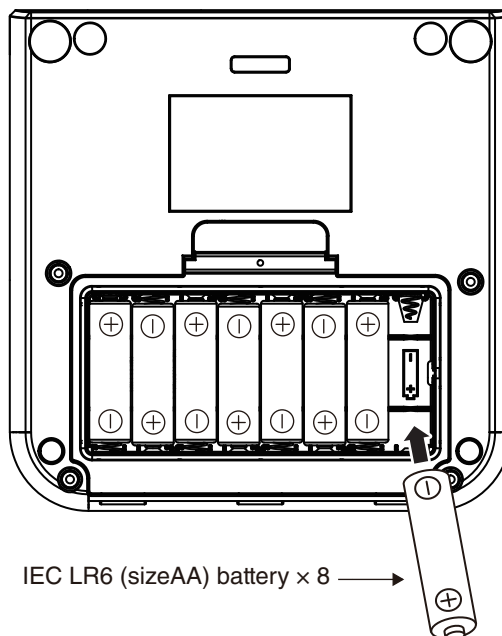

⚠ Caution

Take care not to reverse the (+) and (-) polarity when inserting the batteries. Incorrect setting of the batteries may cause battery explosion and leakage.

To prevent the risk of battery fluid leakage, remove the batteries from the unit when the unit is not used.

If the fluid from inside the battery sticks to your skin or clothing, wash it off immediately with clean water.

Important

Always replace all eight batteries together. To prevent the risk of damage, do not mix old and new batteries or batteries of different type.

Important

The rechargeable nickel metal-hydride battery is not charged by the VM-56.
--

Select the used battery type by the [System] on the menu list screen (see page 46).

Note

The life of rechargeable nickel metal-hydride battery depends on the battery type and charge condition.

AC adapter

To operate the unit with the AC adapter, connect it as shown below.

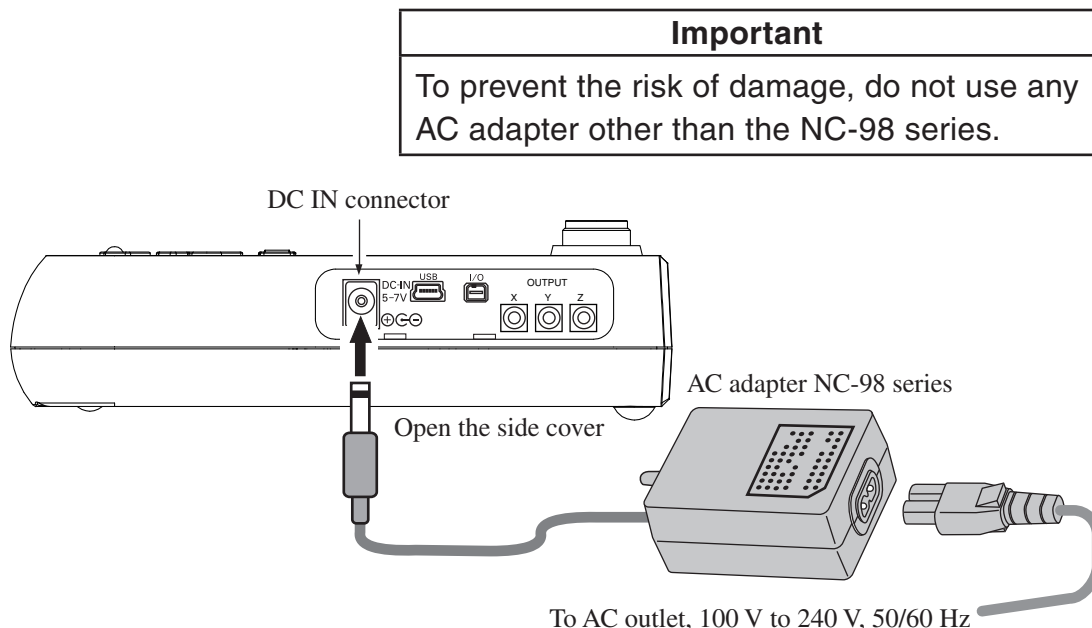

Backup battery

The unit uses a backup battery (rechargeable battery) to operate the clock.

While power to the unit is on, the backup battery will be charged. It will also be charged while power to the unit is off if external power is connected.

The relationship between charging time and retention period is shown below.

A full charge of the backup battery is achieved after 24 hours.

Charging time	Retention period
1 hour	2 days
12 hours	30 days
24 hours	45 days

Use the AC adapter when connecting external power for battery charge while the unit is turned off. The service life of the backup battery is limited. You should have the battery replaced about once every five years. Please contact your supplier.

Note
The charging time, retention period and service life of the backup battery may vary depending on the operating condition.
When the backup battery is old, the retention period will be shorter.

Power on/off

To turn the unit on

Hold down the POWER key until the power-on screen appears (at least 2 seconds). When the screen is shown, release the POWER key. After the unit has been started, the measurement screen appears.

During start up, the indicator LED flashes red → blue → red → ...

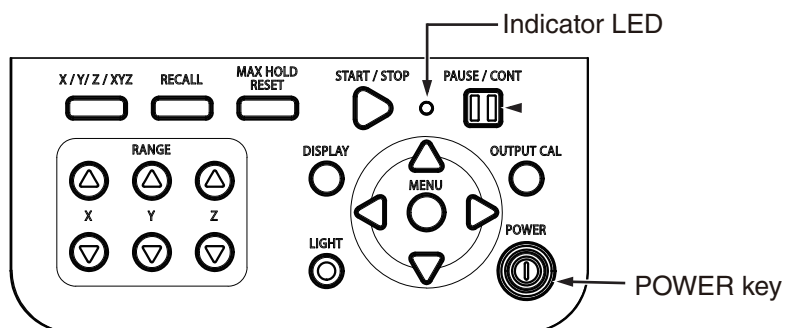

To turn the unit off

Hold down the POWER key until the unit is turned off (several seconds). When the power-off screen appears, release the POWER key.

Important

Remove the batteries from the unit if it is to be stored for a long time with the POWER key set to OFF to prevent possible damage caused by battery leakage.

Note

After turning the unit off, wait at least 10 seconds before turning it on again.

If the key lock has been activated, pressing the POWER key has no effect. Press the ◀ key and ▶ key simultaneously to cancel the key lock condition, and then press the POWER key.

If the key lock has been activated, pressing and holding the POWER key for at least 10 seconds will force a power-down even if the Power-on mode switch (see next page) has been set to the “B” position. In this case, the unit can be turned on again by pressing the POWER key, but you should wait at least 10 seconds before doing so.

Power-on mode switch

Opening the battery compartment as shown below gives access to a switch labeled “A-B”. Normally the “A” position is used. Setting this switch to the “B” position allows the unit to be turned on simply by supplying power to the DC IN connector. In this case, the POWER key on the operation key panel of the unit has no effect.

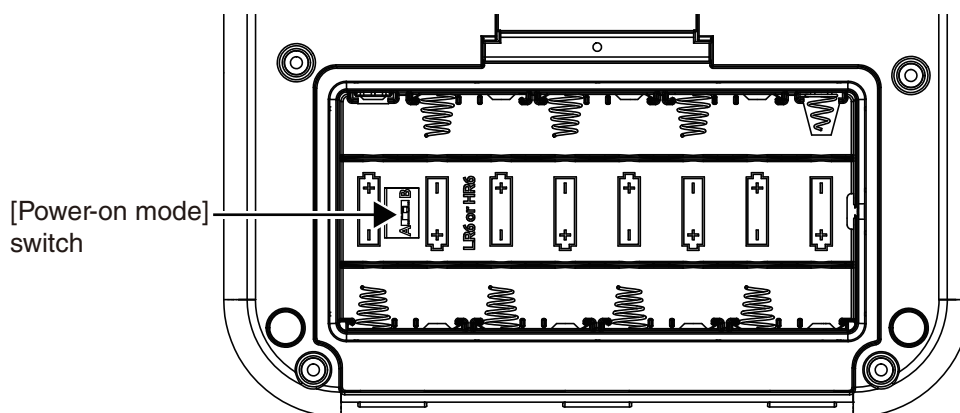

Important

When using the unit with the switch in the “B” position, do not insert batteries.

If the unit is turned off immediately after changing the setting while using the unit with the switch in the “B” position, the setting may not be resumed. After changing the setting, wait at least 10 seconds before turning the unit off.

Vibration pickup placement and connection

Vibration axis

Environmental vibrations are normally measured in two horizontal planes (front/back and left/right) and one vertical plane. This means that complex vibration phenomena are reduced to three axes (X, Y, Z), for easier observation.

The axes are defined as follows (facing the vibration source).

Horizontal front/back: X

Horizontal left/right: Y

Vertical: Z

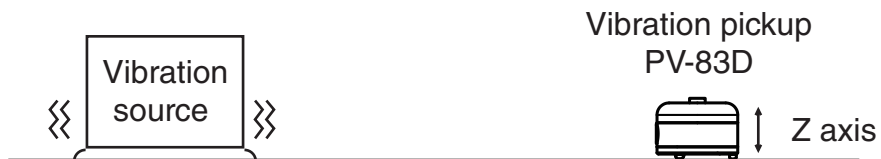

Note

Determine the orientation of horizontal planes in accordance with the applicable specifications.

Vibration Pickup placement

Install the sensor on a solid horizontal plane. As necessary, fasten the sensor with bolts on the vibrating surface. For information on the installation of various plates, see page 88.

Important
Avoid locations exposed to direct sunlight or to drastic temperature changes. Such conditions can cause changes in Vibration pickup sensitivity, which will impair the accuracy of measurement results.

Vibration Pickup connection

Insert the input connector into the tip connector of the pickup and turn the ring clockwise to fix.

Important
The Vibration Pickup is a precision device. Never drop it or subject it to shocks.

Important

Never suspend the vibration pickup by its cord or pull at the cord. Otherwise cord breaks may occur.

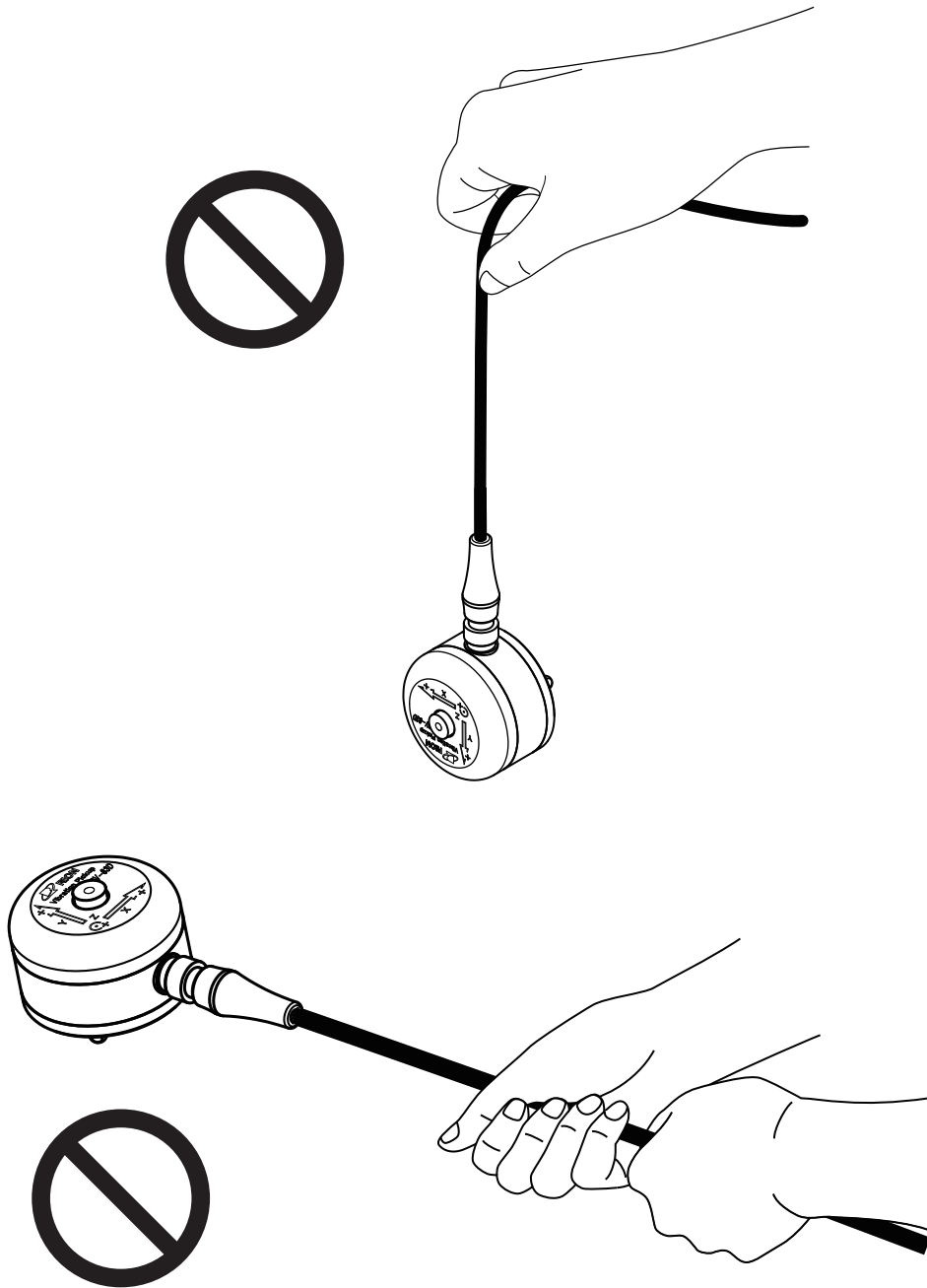

Important

When installing or dismantling a system, always make sure that all connection cords are disconnected from the cord reel. Otherwise cord breaks due to twisting may occur.

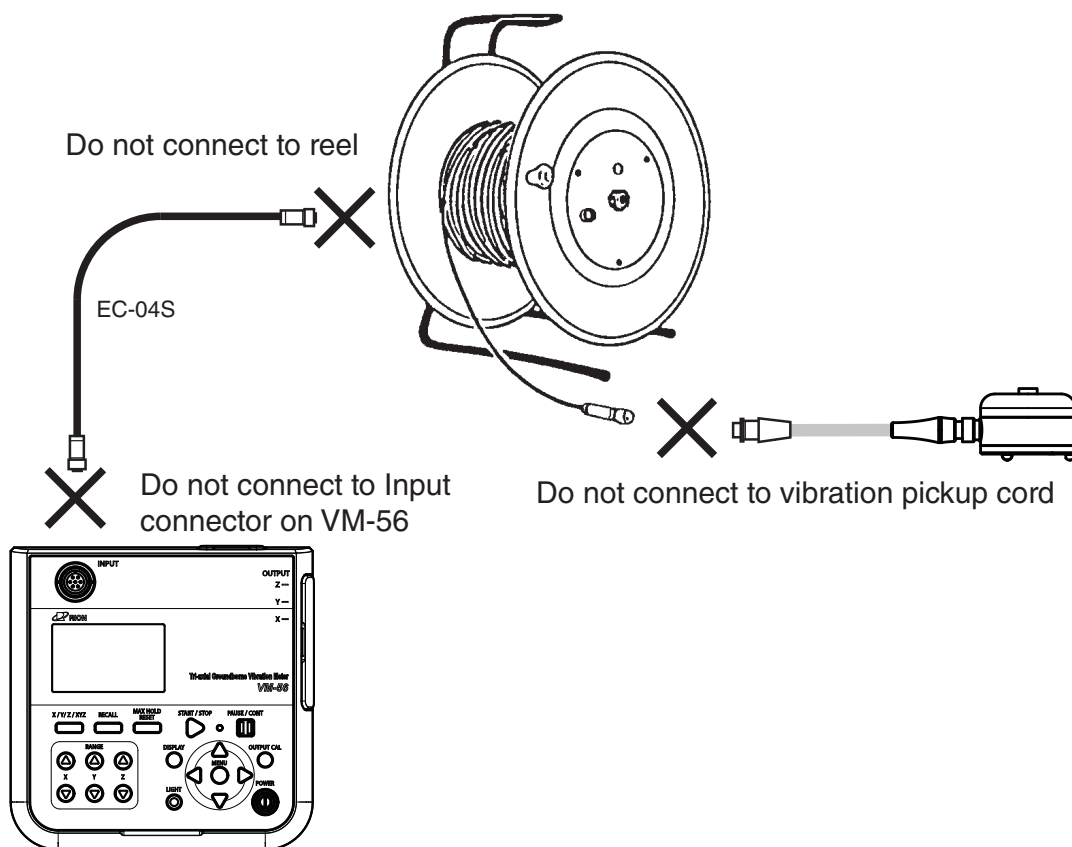

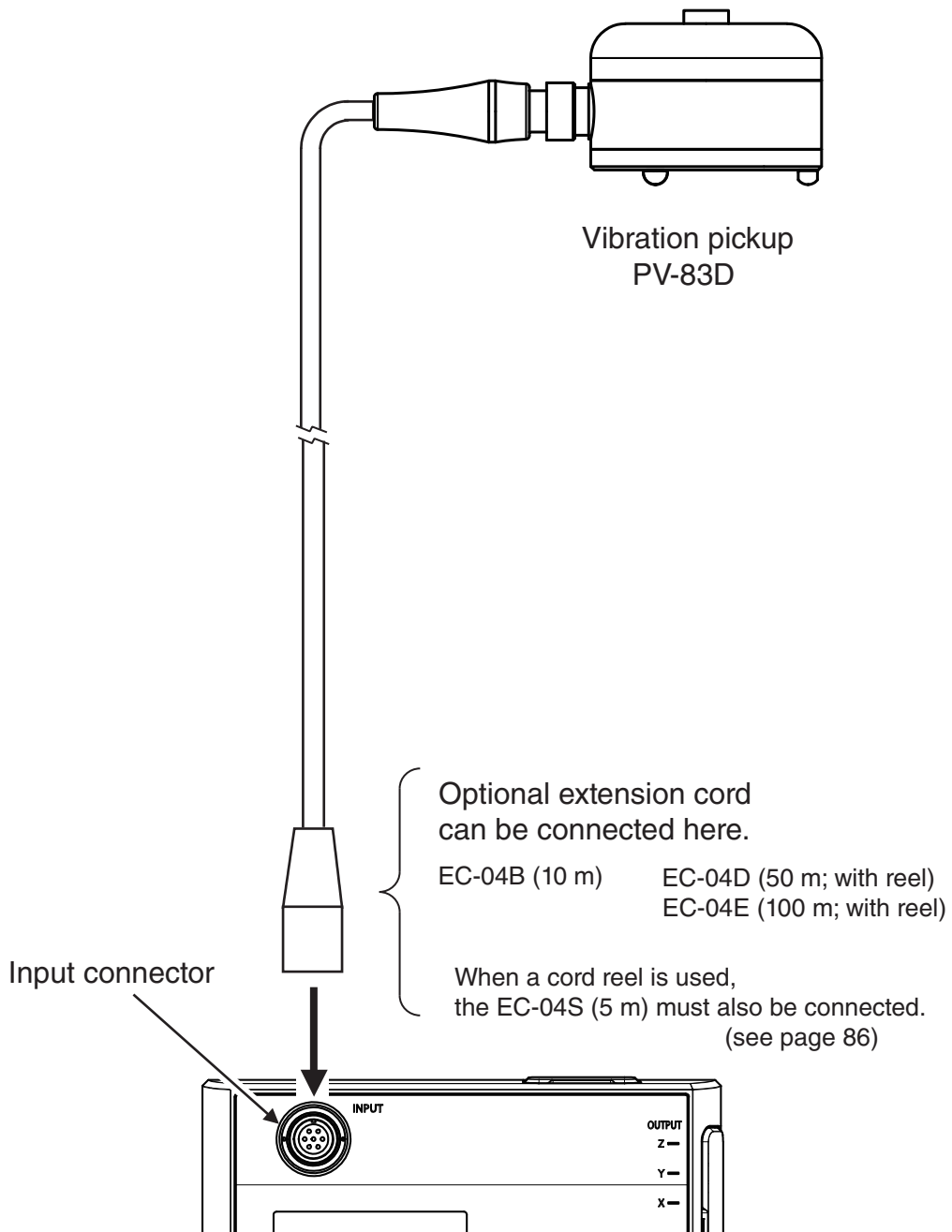

SD memory card and program cards

Measurement data can be stored on an SD memory card for use and further processing in a computer. Optional program cards can also be used for installing software into the unit to expand the measurement functions of the unit.

Inserting a card

Important
Make sure that power is OFF before inserting or removing a card.
Take care to insert the SD memory card with correct orientation.
If the SD memory card is removed while data is being read or written to the card, the data may be destroyed.
Use SD memory cards provided by Rion. The performance of other cards is not guaranteed.
Note that we assume no responsibility for any damage or loss of stored measurement data.

1. Open the top cover of the unit.
2. Insert the SD memory card into the card slot on the top of the unit with the label of the card facing up. Push the card in until it is locked in place.
3. To remove the card, push the card a bit further in, the card is released and pops out of the card slot.

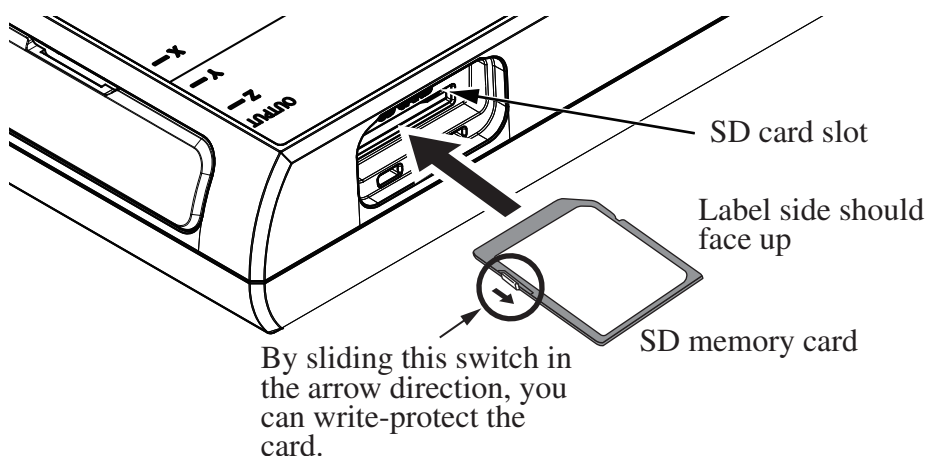

Connection to a data recorder (DA-21), and other device

Connect the OUTPUT connector on the right side of the VM-56 with an input connector of data recorder (DA-21 and other device), using the optional BNC - Pin output cord CC-24 as shown below. The performance of other cables is not guaranteed.

To make settings for signal output ON/OFF, use the Display/ I/O screen. (Set [Output] to “ON”.)

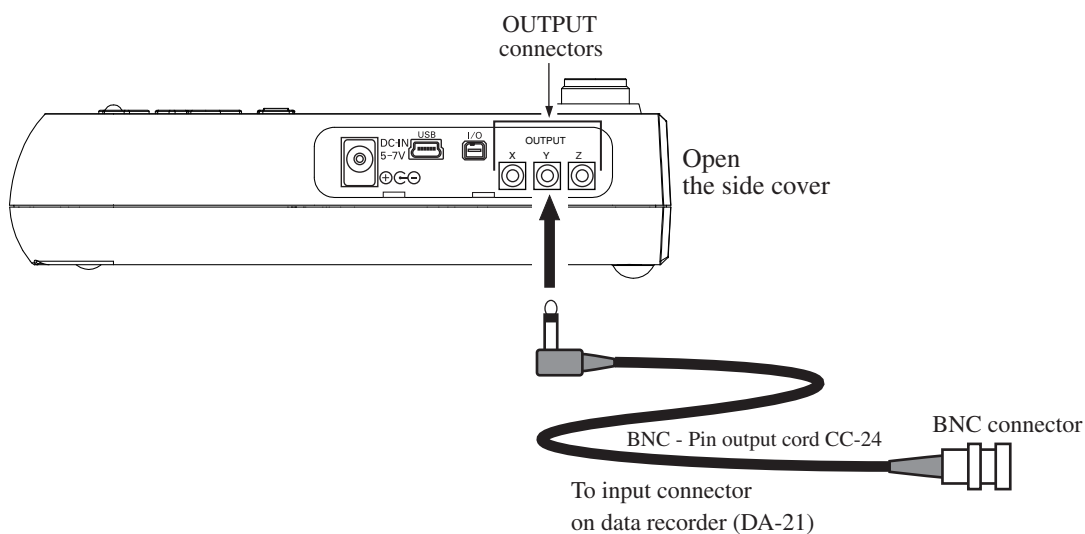

Connection to a computer

Connect the USB connector on the right side of the VM-56 with a USB connector of a computer, using the optional (generic) A - mini B USB cable as shown below.

An SD memory card inserted in the unit will be recognized as a removable disk by the computer when connected via USB, without having to install a USB driver.

Note

If the store operation is being carried out, the unit will not be recognized as a removable disk by the computer.

To control the setting of the VM-56 with USB commands using the communication function, select the [Display / I/O] from the menu list and set the [Communication Interface] to [USB] (see page 37).

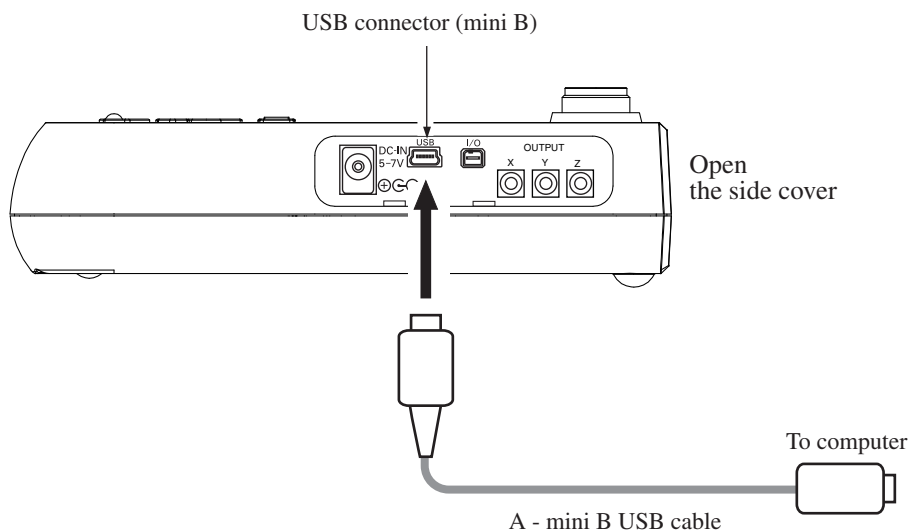

Setting the date and time

The unit incorporates a clock which allows recording the date and time along with measurement data.

Set the date and time as described below.

1. Press the MENU/ENTER key to bring up the menu list screen.
2. Use the $\triangle/\nabla/\triangleleft/\triangleright$ keys to select [System] and press the MENU/ENTER key. The system screen appears.
3. Use the \triangle/∇ keys to select [Clock Setting] and press the MENU/ENTER key. The clock setting screen appears.
4. Use the $\triangleleft/\triangleright$ keys to select [Year], [Month], [Day], [Hour], [Minute] and [Second].
5. Use the \triangle/∇ keys to change the setting of the selected item.
6. Repeat the steps 4 and 5. Press the MENU/ENTER key to complete the setting change. The clock starts moving with the new setting.
7. Press the START/STOP key to return to the measurement screen.

Important

If the unit is not to be used for an extended period, the main batteries should be taken out to prevent possible damage due to battery fluid leakage. After reinserting the batteries, be sure to set the date and time.

Note

The clock in this unit has an error of about 1 minute per month. Before measurement, be sure to check and set the time if required.

An internal rechargeable backup battery serves to keep clock setting on the unit. The backup battery is automatically charged by the main batteries, but the retention period for clock setting depends on charging time (see page 15). Full charge of the backup battery requires approximate 24 hours.



System screen

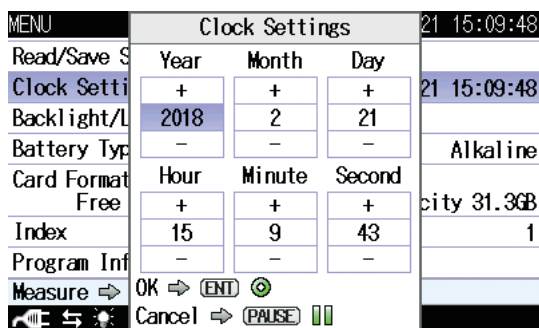

Clock settings screen

Measurement in a dark location

Pressing the LIGHT key will turn on the display backlight, for easier reading in a dark location. The backlight operation pattern can be controlled via a menu, as follows.

1. Press the MENU/ENTER key to bring up the menu list screen.
2. Use the $\Delta/\nabla/\triangleleft/\triangleright$ keys to select [System] and press the MENU/ENTER key. The system screen appears.
3. Use the Δ/∇ keys to select [Backlight/LCD Settings] and press the MENU/ENTER key. The backlight/LCD settings screen appears.
4. Use the Δ/∇ keys to select [Backlight Auto Off] and press the MENU/ENTER key. The backlight auto off screen appears.
5. Use the Δ/∇ keys to select the automatic turn-off interval (30 sec, 3 min, Continue) and press the MENU/ENTER key.
6. Use the Δ/∇ keys to select [Backlight brightness] and press the MENU/ENTER key. The level of brightness screen appears.
7. Use the Δ/∇ keys to select the level of brightness (level 1 to level 4) and press the MENU/ENTER key. (level 1 is dark, and level 4 is bright.)
8. Press the START/STOP key to return to the measurement screen.

To turn the backlight off before the automatic turn-off point, press the LIGHT key.

The [level 4] setting for backlight brightness will reduce battery life by about 30 percent, and the [level 1] setting by about 5 percent.

Note
When there is only one segment (red) on the battery status indicator, the display backlight does not turn on.

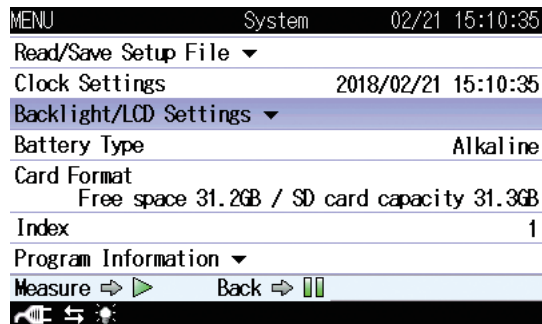

System screen



Backlight/LCD settings screen

Eco setting (Power-saving mode)

The Eco setting enables the power saving feature. A long-time measurement can be performed using batteries only.

1. Press the MENU/ENTER key to bring up the menu list screen.
2. Use the $\Delta/\nabla/\triangleleft/\triangleright$ keys to select [System] and press the MENU/ENTER key. The system screen appears.
3. Use the Δ/∇ keys to select [Eco Setting] and press the MENU/ENTER key. The confirmation screen appears.
4. Use the Δ/∇ keys to select [YES] and press the MENU/ENTER key. The eco setting is executed.
5. Press the START/STOP key to return to the measurement screen.

When the eco setting is executed, the setting of the item is changed automatically as follows.

Backlight auto off	30 sec
Backlight brightness	1
OUTPUT	OFF
Communication interface	OFF
LCD auto off at auto store	1 min



System screen

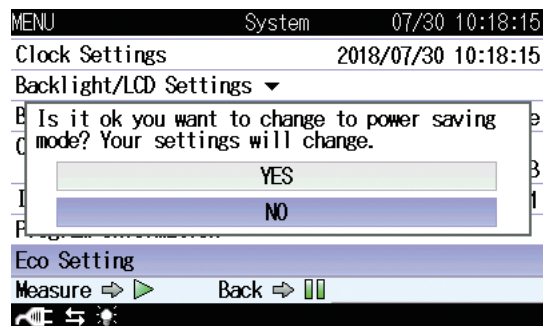

Execution confirmation screen

Calibration

When using external equipment to record measurement data, level calibration should be performed as follows.

1. Press the MENU/ENTER key to bring up the menu list screen.

2. Use the Δ / ∇ / \triangleleft / \triangleright keys to select [Display / I/O] and press the MENU/ENTER key. The display / I/O screen appears.

MENU	Display / I/O	02/21 13:01:09
Time-Level graph	Time Scale	20s
Output ∇		OFF
Comparator ∇		OFF
Communication Interface		OFF

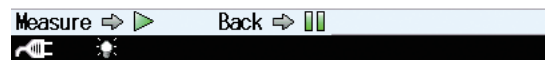

3. Use the Δ / ∇ keys to select [Output] and press the MENU/ENTER key. The output screen appears.
4. Press the MENU/ENTER key. The ON/OFF setting screen appears.

MENU	Output	02/21 13:12:38										
Output		OFF										
<table border="1"> <tr> <td colspan="2" style="text-align: center;">Output</td> </tr> <tr> <td style="text-align: center;"><input checked="" type="checkbox"/></td> <td style="text-align: center;">OFF</td> </tr> <tr> <td style="text-align: center;"><input type="checkbox"/></td> <td style="text-align: center;">ON</td> </tr> <tr> <td>OK \Rightarrow</td> <td>ENT \odot</td> </tr> <tr> <td>Cancel \Rightarrow</td> <td>PAUSE \parallel</td> </tr> </table>			Output		<input checked="" type="checkbox"/>	OFF	<input type="checkbox"/>	ON	OK \Rightarrow	ENT \odot	Cancel \Rightarrow	PAUSE \parallel
Output												
<input checked="" type="checkbox"/>	OFF											
<input type="checkbox"/>	ON											
OK \Rightarrow	ENT \odot											
Cancel \Rightarrow	PAUSE \parallel											
Measure \Rightarrow		Back \Rightarrow \parallel										

5. Use the Δ / ∇ keys to select [ON] and press the MENU/ENTER key.

MENU	Output	02/21 13:13:53
Output		ON
Quantity		Acc.
Freq.		Non-Weighting



6. Press the START/STOP key to return to the measurement screen.
7. Press the OUTPUT CAL key.

The display switches to calibration indication.

Verify that the measurement value reading is the same as the maximum value for the range in each axis (X, Y, Z).

During calibration, the OUTPUT connectors supply the following signal.

AC : 15.85 Hz, 1 Vrms (OUTPUT setting is “AC OUT”)

Use this signal to calibrate the external equipment such as a level recorder or analyzer.

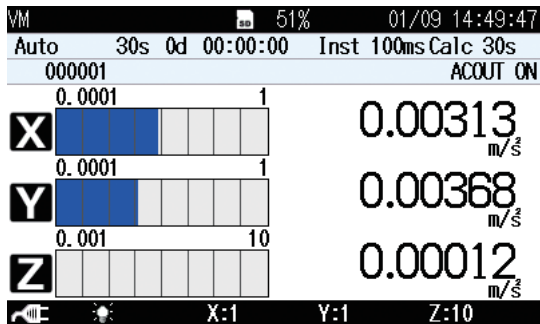
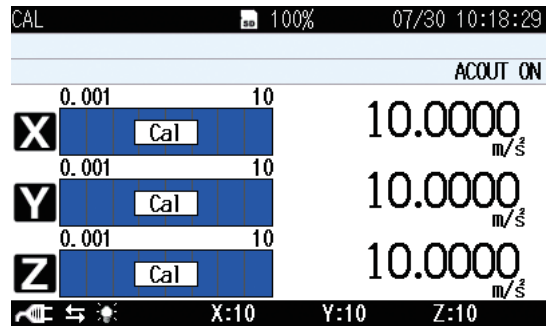

Measurement screen

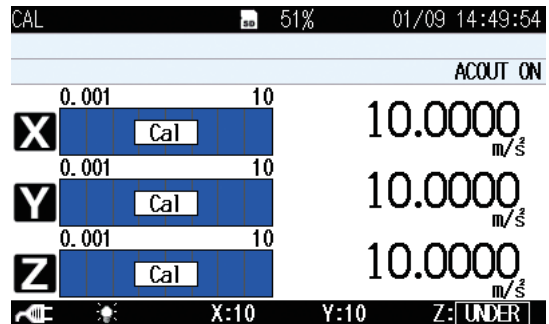

OUTPUT CAL screen

If any one of X, Y, Z-axis RANGE is set to 10, all RANGE is changed to 10 only on the OUTPUT CAL screen.

When returning to the measurement screen from the OUTPUT CAL screen, the RANGE of X, Y, Z-axis returns to the value set on the measurement screen.

8. Press the OUTPUT CAL key again to cancel the calibration mode.

Reading the Display

Measurement screen display

The illustration below shows all elements of the display for explanation purposes. In actual operation, such a screen will not be shown. (In case of 1 channel screen indication.)

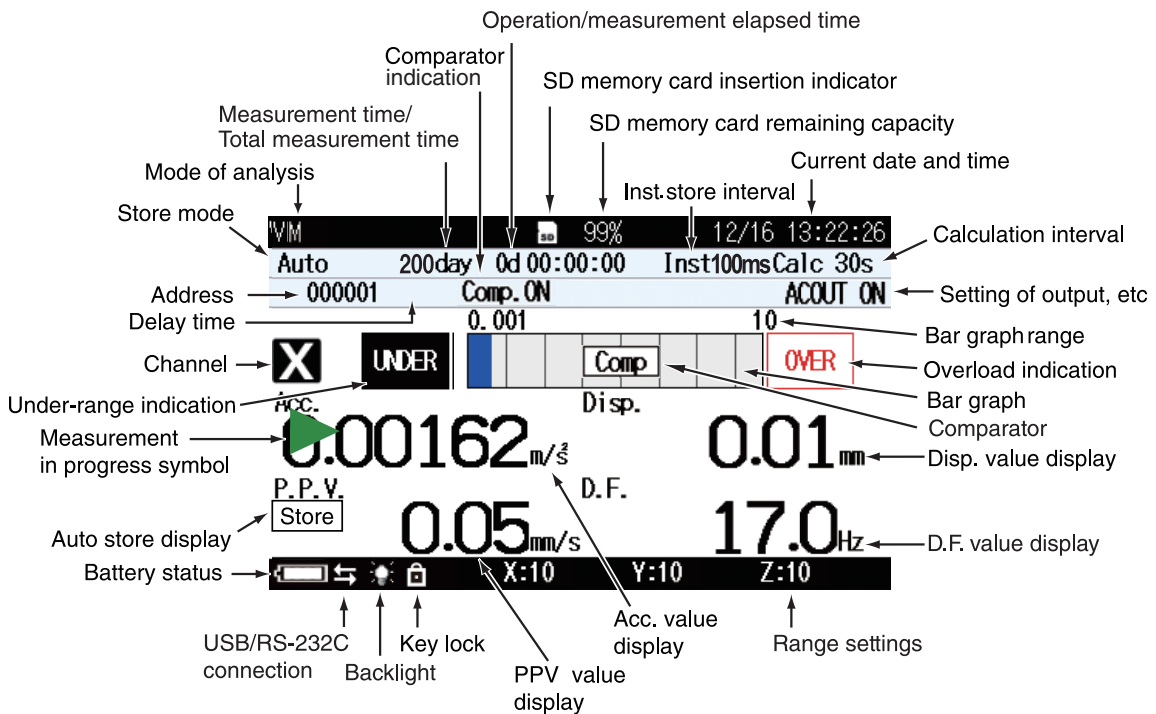

Mode of analysis

Indicates the condition of the display screen.

Measurement time/Total measurement time

When the store mode is Manual, the Measurement time is displayed.

When the store mode is Auto, the Total measurement time is displayed

Comparator

Display when comparator is set (see page 55, 69)

Operation/measurement elapsed time

Shows the elapsed time from the start of measurement.

SD memory card insertion indicator

Shown when an SD memory card is inserted in the unit (see page 23).

SD memory card remaining capacity

Shows the remaining capacity of an inserted SD memory card.

Note
Even when a new SD memory card is inserted, the remaining capacity may sometimes be shown as 99% rather than 100%.

Inst. store interval

When the store mode is Auto or Timer Auto, the Inst. store interval is displayed (see page 51).

Current date and time

Shows the current date and time.

Calculation interval

When the store mode is Auto or Timer Auto, the Calculation interval is displayed (see page 51).

Setting of output, etc

The selected output signal on the [OUTPUT] of the [Display / I/O] screen is shown here (see page 55).

Bar graph range

Shows the upper and lower limit of the bar graph. The range can be changed using the RANGE key on the control section.

Overload indication

When a signal overload condition of the acceleration value is detected, the indication **OVER** (white on black) is shown for at least 8 second.

If processed data contain signal overload data, the indication **OVER** is shown. This indication remains on the processed data display screen until the next processing measurement is started.

Under-range indication

When a signal under-range condition of the vibration acceleration level is detected, the indication **UNDER** (white on black) is shown for at least 8 second.

If processed data contain signal under-range data, the indication **UNDER** is shown. This indication remains on the processed data display screen until the next processing measurement is started.

Bar graph

Shows the acceleration value as a bar graph indication. (The display is updated every 100 msec.)

Acc. value display

Display the RMS value of the acceleration.

PPV value display

Display the peak particle velocity value.

D.F. value display

Display the dominant frequency value.

Disp. value display

Display the 0 to peak value of displacement.

Range settings

Shows the upper limit of the range (X, Y, Z). **OVER** is shown here when a signal overload condition has been detected, and **UNDER** is shown when a signal under-range condition has been detected.

Key lock

Indicates that the key lock function has been set to ON (see page 6).

Backlight

Indicates that the display backlight has been light up (see page 28).

If the remaining battery capacity indication or the power supply plug symbol is shown in red, the backlight will not come on.

USB/RS-232C connection

Indicates that the communication control function has been set to USB or RS-232C (see page 56).

Battery status

When the unit is operated on battery power, you should regularly check this indication. The number of white segments will decrease as the batteries get used up. When the indication starts to flash in red, replace the batteries with a fresh set.

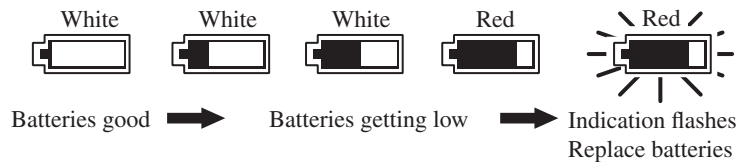

When the unit is being powered from an AC adapter or a battery pack, the  symbol is shown.

Auto store display

When the store mode is Auto or Timer Auto, this indication flashes during measurement. The indication is off when data are stored in memory.

During waveform recording using the optional Waveform Recording Program VX-56WR, the indications “Store” and “REC.” are shown alternately on the display

Measurement in progress symbol

When a measurement is in progress, the ► symbol flashes. The indicator LED also flashes in red.

During auto store, the ► symbol also flashes. The indicator LED flashes in red.

During measurement standby, the ■ symbol is shown. The indicator LED flashes in blue once every 5 seconds.

During measurement pause, the || symbol is shown. The indicator LED flashes in blue.

Channel

Shows the selected channel.

Delay time

Shows the delayed measurement time set by “Delay Time”.

Address

Shows the current memory address. In manual store mode, the indication is red if there are data in that address.

Store mode

Shows the selected mode for storing data in memory (Manual, Auto, or Timer Auto) (see page 71).

Measurement screen

When the measurement screen is displayed.

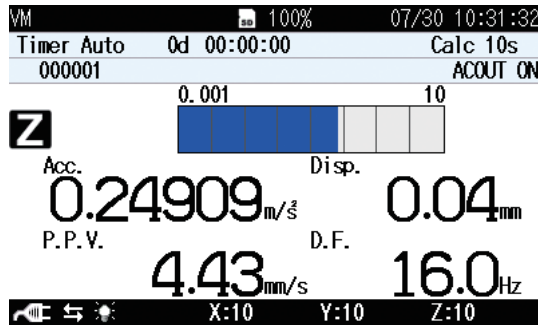

Measurement screen (3 channels display)

When the measurement screen is displayed, pressing the X/Y/Z/XYZ key changes the channel display as shown below.

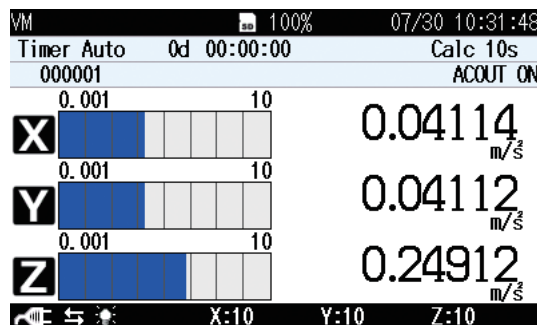

Max Hold display screen

When the measurement screen is displayed, pressing the DISPLAY key brings up the Max Hold display screen as shown below.

Pressing the X/Y/Z/XYZ key switches the vibration axis (channel) to be shown on the display.

Pressing the MAX HOLD RESET key resets the value of the max hold function. The value is reset once when the measurement is started with the Maxhold reset button.

Note

The Max Hold value is reset in the following cases:

- The MAX HOLD RESET key was pressed.
- A measurement was started.
- The Timer Auto Interval setting is ON, and the measurement was restarted (see page 67).

1 channel display

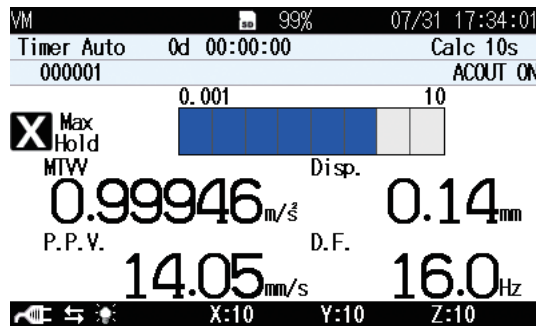

3 channels display

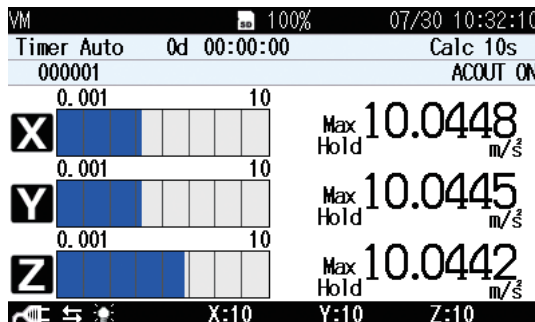

Processed data display screen

When the Max Hold display screen is displayed, pressing the DISPLAY key brings up the processed data display screen as shown below.

Pressing the X/Y/Z/XYZ key switches the vibration axis (channel) to be shown on the display.

Acc. rms value

Display time-averaged weighted acceleration value during computation period.

C.F. value

Display crest factor value calculated from acceleration effective value and acceleration peak value during calculation period.

MTVV value

Display maximum transient vibration value during calculation period.

VDV value

Display vibration dose value during calculation period.

PPV value

Display peak particle velocity during calculation period.

D.F. rms value

Display the dominant frequency of the obtained PPV value.

Disp. value

Display 0 to peak displacement during the calculation period.

KBFmax

Display the maximum value of KBF (t) during the measurement period.

KBFT

Display the maximum value of KBF (t) during a 30-second measurement period.

PVS

Display peak vector sum during calculation period.

veff,max

Display the maximum value of v_{eff} (t) during the measurement period.

veff,max,30

Display the maximum value of v_{eff} (t) during a 30-second measurement period.

1 channel display

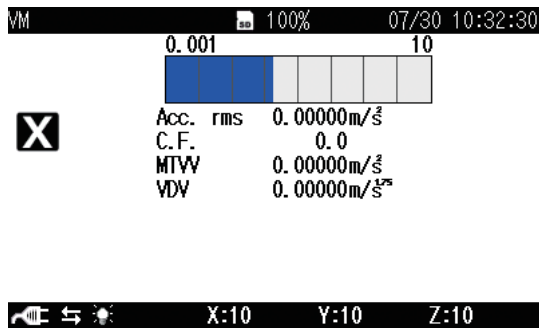

3 channels display

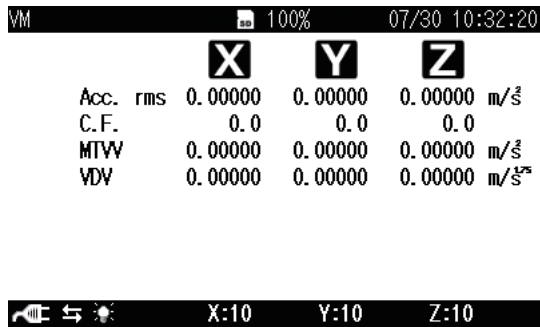

Time-level display screen

When the processed data display screen is displayed, pressing the DISPLAY key brings up the time-level display screen as shown below.

Pressing the X/Y/Z/XYZ key switches the vibration axis (channel) to be shown on the display.

1 channel display

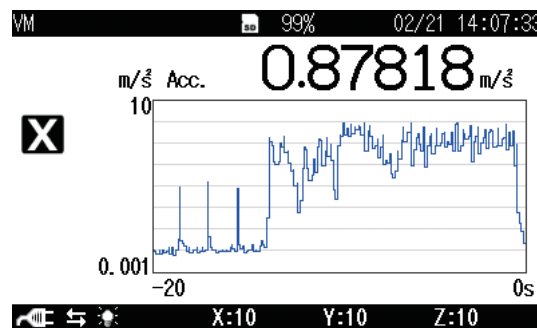

3 channels display

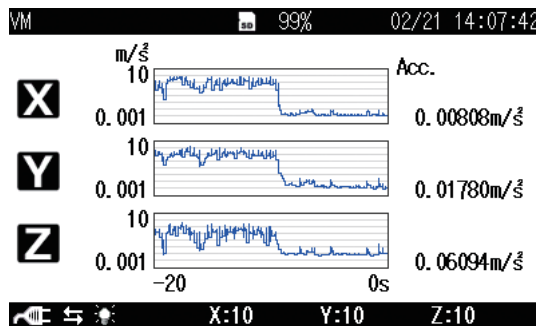

Indicator messages

After the power is turned on, a message is displayed as shown below.

Warm up

POWER key is pushed, until about 1 minute 30 seconds have elapsed since startup.

When keys such as START/STOP is pressed, indicator messages such as shown below will appear on the display for about 1 second.

START

When START/STOP key was pressed and processing has started

PAUSE

When PAUSE/CONT key was pressed and operation is paused

CONTINUE

When PAUSE/CONT key was pressed and processing has resumed

STOP

When START/STOP key was pressed and processing has ended

Menu list screen

When the measurement screen is displayed, pressing the MENU/ENTER key brings up the menu list screen as shown below.

Use the Δ / ∇ / \triangleleft / \triangleright keys to select the desired menu and press the MENU/ENTER key.

Pressing the PAUSE/CONT key or the START/STOP key switches back to the measurement screen.



Note

When optional Waveform Recording Program VX-56WR is not installed, “WR” is not displayed on the menu list screen.

System

This screen sets the item concerning the system of the unit.

Use the Δ / ∇ / \triangleleft / \triangleright keys to select [System] and press the MENU/ENTER key. The system screen appears.

Each item of the system screen is selected using the Δ / ∇ key.

Pressing the PAUSE/CONT key switches back to the menu list screen.

Pressing the START/STOP key switches back to the measurement screen.

MENU	System	02/21 14:10:54
Read/Save Setup File ▾		
Clock Settings	2018/02/21	14:10:54
Backlight/LCD Settings ▾		
Battery Type		Alkaline
Card Format		Free space 31.3GB / SD card capacity 31.3GB
Index		1
Program Information ▾		
Measure \Rightarrow \triangleright	Back \Rightarrow \parallel	

MENU	System	02/21 14:11:57
Language		English
Read/Save Setup File ▾		
Clock Settings	2018/02/21	14:11:57
Backlight/LCD Settings ▾		
Battery Type		Alkaline
Card Format		Free space 31.3GB / SD card capacity 31.3GB
Index		1
Measure \Rightarrow \triangleright	Back \Rightarrow \parallel	

Read/Save setting ▾

Displays the screen to save a setting for the unit and read the saved setting. Select [Read/Save setting] and press the MENU/ENTER key. The setting operation screen appears (see page 83).

Clock Settings

Displays the screen to set date and time of the internal clock of the unit. Select [Clock Settings] and press the MENU/ENTER key. The clock settings screen appears (see page 26).

Backlight/LCD Settings ▾

Displays the screen to set the function of the backlight and the LCD of the unit.

Select [Backlight/LCD Settings] and press the MENU/ENTER key. The backlight/LCD settings screen appears (see page 28).

Battery Type

Displays the screen to select the type of battery used for the unit. The battery power corresponding to the selected battery is displayed on the measurement screen.

Select [Battery type] and press the MENU/ENTER key. The battery type screen appears.

Use the Δ/∇ keys to select the battery type (Alkaline, Ni-MH [Nickel-metal hydride]) and press the MENU/ENTER key.

Card Format (can only be selected when SD memory card is inserted)

Formats the inserted SD memory card.

Select [Card Format] and press the MENU/ENTER key. The confirmation screen appears.

Select [YES] and press the MENU/ENTER key to format the card.

Select [NO] and press the MENU/ENTER key when not formatting the card.

Free space / SD card capacity

Displays the free space and the memory capacity of the inserted SD memory card. The both free space and memory capacity are read by the automatic operation, and cannot be changed.

Note
<p>If the following operation is performed while the USB cable is connected, the free space will not be displayed correctly. In this case, cycle the power to the unit, or remove the SD memory card and insert it again.</p> <p>* Have this unit recognized as a removable disk, move the data to a computer and then move the data back to the unit.</p>
<p>Even when a new SD memory card is inserted, the remaining capacity may sometimes be shown as 99% rather than 100%.</p>

Index

Displays the screen to set the identification number of the unit when multiple units are used in a parallel measurement.

Select [Index] and press the MENU/ENTER key. The index screen appears.

Use the $\triangleleft/\triangleright$ keys to select the digit, and use the \triangle/∇ keys to set the value (1 to 255). Then press the MENU/ENTER key. The index is also recorded in store data.

Note
Measurement data cannot be selected when recalling it on a unit with a different index number (viewing impossible).

Program Information \blacktriangledown

Displays the version information screen of the program of the unit.

Select [Program Information] and press the MENU/ENTER key. The program information screen appears.

Eco Setting (Power saving mode)

Enters the power-saving mode.

Select [Eco Setting] and press the MENU/ENTER key. The confirmation screen appears (see page 30).

Store

This screen sets the mode that stores the operation result data.

Use the $\Delta/\nabla/\triangleleft/\triangleright$ keys to select [Store] and press the MENU/ENTER key. The store screen appears.

Each item of the store screen is selected using the Δ/∇ key.

Pressing the PAUSE/CONT key switches back to the menu list screen.

Pressing the START/STOP key switches back to the measurement screen.

As for the store screen, the displayed set item is different depending on the set store mode.

For details, please refer to “Store operation” on page 71.

MENU	Store	02/21 14:13:39
Store Mode	Manual	
Store Name	0006	
Measurement Time	10min	
Measure \Rightarrow \triangleright Back \Rightarrow $\parallel\parallel$		

Manual

MENU	Store	12/17 14:17:15
Store Mode	Auto	
Store Name	0046	
Total Measurement Time	8h	
Inst Store Interval	100ms	
Calculation Interval	30s	
Level Trigger	ON	
Trigger Value	Z P.P. V.	
Trigger Level	0.05mm/s	
Measure \Rightarrow \triangleright Back \Rightarrow $\parallel\parallel$		

Auto

MENU	Store	02/21 14:15:29
Store Mode	Timer Auto	
Store Name	0006	
Inst Store Interval	OFF	
Calculation Interval	10s	
Timer Auto Start	2018/02/21 14:19	
Timer Auto Stop	2018/02/21 18:15	
Timer Auto Interval	5min	
Sleep Mode	ON	
Measure \Rightarrow \triangleright Back \Rightarrow $\parallel\parallel$		

Timer Auto

Store Mode

Displays the screen to select the store mode.

Select [Store Mode] and press the MENU/ENTER key. The store mode setting screen appears.

Use the Δ/∇ keys to select the store mode (Manual, Auto, Timer Auto) and press the MENU/ENTER key.

Store Name (common to each mode)

Displays the screen to set the identification number of the store data (0000 to 9999).

Select [Store Name] and press the MENU/ENTER key. The store name screen appears.

Measurement Time (Manual mode)

Displays the screen to select the measurement time in the Manual mode.

Select [Measurement Time] and press the MENU/ENTER key. The measurement time screen appears.

Total Measurement Time (Auto mode)

Displays the screen to select the total measurement time in the auto mode. Select [Total Measurement Time] and press the MENU/ENTER key. The total measurement time screen appears.

Even the Total Measurement Time was set, the actual measurement time will differ, depending on whether Level Trigger is set to ON or OFF.

For detailed information, please refer to pages 65 and 66.

User setting (Manual mode and Auto mode)

When [Manual] is selected from [Measurement Time] of the Manual mode or [Total Measurement Time] of the Auto mode, the user setting items will be displayed and measurement time can be set arbitrarily.

The maximum settable time is 24 hours with the Manual mode. In Auto mode, the maximum settable time is 41 days when “Inst store 100 ms” is ON, and 200 days when it is OFF.

Inst. Store Interval (Auto mode and Timer Auto mode)

Displays the screen to select the Inst. store interval in the Auto mode or Timer Auto mode.

Select [Inst. Store Interval] and press the MENU/ENTER key. The Inst. store interval screen appears.

Calculation Interval (Auto mode and Timer Auto mode)

Displays the screen to select the calculation interval in the Auto mode or Timer Auto mode.

Select [Calculation Interval] and press the MENU/ENTER key. The calculation interval screen appears.

Timer Auto Start (Timer Auto mode)

Displays the screen to set the measurement start time in the Timer Auto mode.

Select [Start] and press the MENU/ENTER key. The start time setting screen appears.

When the start time setting screen is displayed for the first time, the time after 5 minutes from current time is indicated.

Timer Auto Stop (Timer Auto mode)

Displays the screen to set the measurement stop time in the Timer Auto mode.

Select [Stop] and press the MENU/ENTER key. The stop time setting screen appears.

Timer Auto Interval (Timer Auto mode)

Displays the screen to select the timer auto interval in the Timer Auto mode.

Select [Timer Auto Interval] and press the MENU/ENTER key. The timer auto interval screen appears.

Sleep Mode (Timer Auto mode)

Displays the screen to select whether to set the sleep mode.

Select [Sleep Mode] and press the MENU/ENTER key. The ON/OFF setting screen appears.

When sleep mode is enabled, the unit will enter a power-saving standby condition at 60 seconds after pressing the START/STOP key and during intervals between measurements. In this mode, power consumption is reduced to about 1/10. The LCD panel is off, and the indicator LED flashes in blue once every 5 seconds. 4 minutes seconds before the start of measurement, the unit will wake up and go into standby until measurement begins.

To check the measurement settings in standby condition, press the LIGHT key. The display will come on temporarily and will turn itself off again if no further operation steps are taken. During sleep mode, the LCD panel is off, and the AC outputs, USB connector, RS-232C etc. are also disabled. If one of these functions is required, set the sleep mode to OFF.

Level Trigger (Auto mode)

This function becomes available when the Level Trigger function is ON.

MENU	Store	12/17 14:16:59
Store Mode		Auto
Store Name		0046
Total Measurement Time	User setting	
	User setting	3min
Inst Store Interval		100ms
Calculation Interval		30s
Level Trigger		ON
Trigger Value		Z P.P.V.
Measure →	▶	Back →

Trigger Value (Auto mode)

The trigger value can be selected from “P.V.S.”, “X.P.P.V.”, “Y.P.P.V.”, or “Z.P.P.V.”.

MENU	Store	12/17 14:17:23
Store Mode		Auto
Store Name		0046
Total Measu		8h
Inst Store		100ms
Calculatio		30s
Level Trigg		ON
Trigger Val	OK → ENT	P.V.S.
Trigger Lev	Cancel → PAUSE	0.05mm/s
Measure →	▶	Back →

Trigger Level (Auto mode)

The trigger level can be set in the range from 0.05 mm/s to 100.00 mm/s.

MENU	Store	12/17 14:17:29
Store Mode		Auto
Store Name		0046
Total Mea		8h
Inst Sto		100ms
Calculat		30s
Level Tr		ON
Trigger		P.V.S.
Trigger		0.05mm/s
Measure →	▶	Back →

Trigger Pretime (Auto mode)

The Pretime setting can be used to store measurement data from either 1 or 5 seconds before the actual trigger start time.

However, the Pretime setting cannot be longer than the Total Measurement Time.

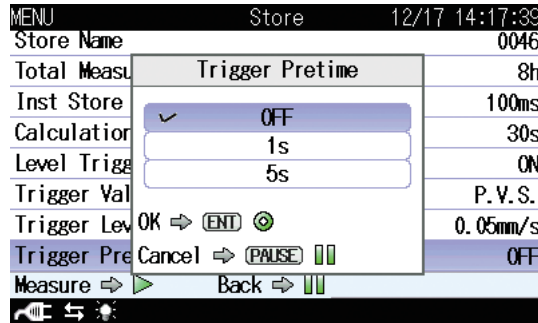

When the Level Trigger function is ON, pressing the START/STOP key once will put the unit into the trigger standby condition. Measurement begins when the preset trigger level of the trigger value is exceeded. When the level falls below the trigger level, measurement is performed according to the Total Measurement Time setting. If the level at the end of the Total Measurement Time is not above the trigger level, the unit reverts to the trigger standby condition. If the level is above the trigger level, measurement continues. If the SD memory card becomes full, or when the maximum data count is reached, the measurement is stopped. The unit will not revert to the trigger standby condition in such a case (data will not be overwritten). To stop a measurement in progress, you can press the START/STOP key.

If the VX-56WR program is installed, the same store action as described above applies also to WAVE files.

Display / I/O

This screen sets the type of output signal etc.

Use the $\Delta/\nabla/\triangleleft/\triangleright$ keys to select [Display / I/O] and press the MENU/ENTER key. The display / I/O screen appears.

Each item of the display / I/O screen is selected using the Δ/∇ key.

Pressing the PAUSE/CONT key switches back to the menu list screen.

Pressing the START/STOP key switches back to the measurement screen.

MENU	Display / I/O	02/21 14:18:03
Time-Level graph Time Scale		20s
Output ▾		OFF
Comparator ▾		OFF
Communication Interface		OFF



Time-Level graph Time Scale

Displays the screen to select the time scale of the time-level graph.

Select [Time-Level graph Time Scale] and press the MENU/ENTER key.

The Time-Level graph Time Scale setting screen appears.

Use the Δ/∇ keys to select the time scale (20s, 1min, 2min) and press the MENU/ENTER key.

Output ▾

Displays the screen to select the signal output from the OUTPUT connectors of the unit.

Select [Output] and press the MENU/ENTER key. The output screen appears (see page 77).

Comparator ▾

Displays the screen to set the comparator signal output (open collector output can be used to control external equipment) from the I/O connector of the unit.

Select [Comparator] and press the MENU/ENTER key. The comparator screen appears (see page 69).

Communication Interface

Displays the screen to select a type of communication with a computer or printer to be connected to the unit.

Select [Communication Interface] and press the MENU/ENTER key. The communication interface screen appears.

Use the Δ/∇ keys to select the communication type (OFF, USB, RS-232C) and press the MENU/ENTER key.

Baud rate

Displays the screen to select the baud rate value when [Communication Interface] is set to "RS-232C".

Select [Baud rate] and press the MENU/ENTER key. The baud rate screen appears.

Use the Δ/∇ keys to select the baud rate value (38400 bps, 57600 bps, 115200 bps) and press the MENU/ENTER key.

Flow control

Displays the screen to select the baud rate value when [Communication Interface] is set to "RS-232C".

Select [Flow control] and press the MENU/ENTER key. The flow control screen appears.

Use the Δ/∇ keys to select the flow control type (OFF, HARD, SOFT) and press the MENU/ENTER key.

Save

Use the $\triangle/\nabla/\triangleleft/\triangleright$ keys to select [Save] and press the MENU/ENTER key. The save screen appears.

Each item of the save screen is selected using the \triangle/∇ key.

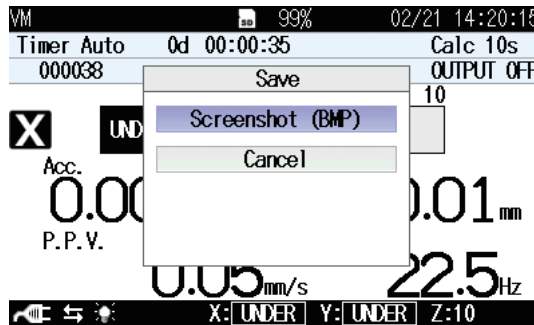

Screenshot (BMP)

Saves the displayed measurement screen to the internal memory in BMP (bitmap) format.

Select [Screenshot (BMP)] and press the MENU/ENTER key.

The data capacity is approximately 300 kB per file.

Screen data can also be saved by holding down the DISPLAY key and pressing the \triangleright key of the $\triangle/\nabla/\triangleleft/\triangleright$ keys (see page 74).

Cancel

Shuts the save screen.

Select [Cancel] and press the MENU/ENTER key.

Option

This screen switches the function from the unit to each program when an optional program is installed.

Use the Δ / ∇ / \triangleleft / \triangleright keys to select [Option] and press the MENU/ENTER key. The option screen appears.

Each item of the switch function screen is selected using the Δ / ∇ key.

Pressing the PAUSE/CONT key switches back to the menu list screen.

Pressing the START/STOP key switches back to the measurement screen.

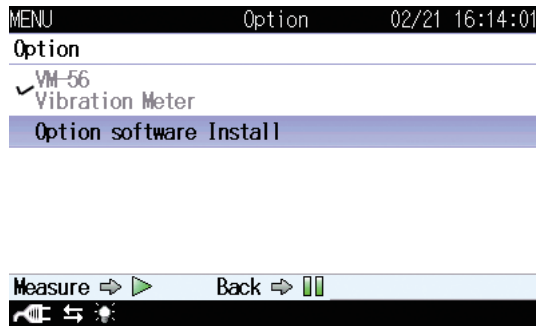

Option

Select a desired program name to switch the function.

Select the program name to be used and press the MENU/ENTER key.

Program names which are not installed will not be displayed.

Measure

This screen sets frequency weighting and the delay time.

The setting items of Measure are different in Standard and SBR of Standard setting respectively.

Use the Δ / ∇ / \triangleleft / \triangleright keys to select [Measure] and press the MENU/ENTER key. The measurement setting screen appears.

Pressing the PAUSE/CONT key switches back to the menu list screen.

Pressing the START/STOP key switches back to the measurement screen.



Freq. weighting for Acc.

You can switch between frequency weighting properties applicable to the acceleration signal. You can also set properties for the X-, Y-, and Z-axis. When “Non-Weighting” is selected, only the frequency range limit becomes selectable—the weighting property is not selectable.

Freq. range for Vel.

This sets a frequency range for the velocity signal and the displacement signal. The same frequency range is set for the three axes.

Freq. Range for Vel. and Disp. (Building Damage)

Freq. Range for Vel. (Human Exposure)

Dominant Frequency

Setting for determining the dominant frequency.

In accordance with the type of building vibration to be measured, calculate the frequency with the highest spectrum from the ratio of the dominant frequency calculated from measured PPV and the regulated value specified in DIN 4150-3 as the dominant frequency.

- Line1 is “Buildings used for commercial purposes, industrial buildings, and buildings of similar design”
- Line2 is “Dwellings and buildings of similar design and/or occupancy”
- Line3 is Structures that, because of their particular sensitivity to vibration, cannot be classified under Line1 and Line2 and are of great intrinsic value (e.g. listed buildings under preservation order)

When No Line is selected, the frequency with the highest spectrum is calculated as the dominant frequency from the FFT result.

Standard

Select the General mode when measuring according to DIN or ISO, select SBR mode when measuring according to SBR. Evaluation values can be displayed and stored according to those settings.

Delay Time

Displays the screen to select the delayed measurement time that is an interval starting at the point the start key is pressed.

Select [Delay Time] and press the MENU/ENTER key. The delay time screen appears.

The delayed measurement is invalid at Timer Auto store.

The delay time setting is inactive when Timer Auto store and Level Trigger for Timer Auto store have been set.

Recall

This screen displays a stored data list on internal memory or SD memory card.

Use the $\triangle/\nabla/\triangleleft/\triangleright$ keys to select [Recall] and press the MENU/ENTER key. The recall screen appears.

Use the $\triangleleft/\triangleright$ keys to display a save location of data.

Pressing the PAUSE/CONT key switches back to the menu list screen.

Pressing the START/STOP key switches back to the measurement screen.

Note

It may take some time to read data and display the recall screen if the volume of stored data is large.

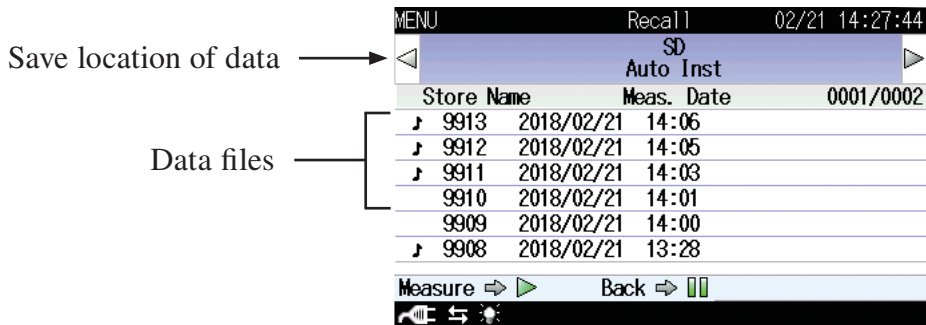

The save location of data can be “Internal Memory Manual”, “SD Manual”, “SD Auto Inst.” or “SD Auto Calc.”. Without an SD memory card, only “Internal Memory Manual” is available.

Note

If a data file saved on a computer is copied or manipulated, and the copied file is then loaded back into the VM-56, the displayed measurement date and time may not match the actual time stamp of the measurement.

Select data file and press the MENU/ENTER key. The file processing screen appears.



View the data

Displays the measurement data of the selected data file.

Select [View the data] and press the MENU/ENTER key.

You can use the Δ/∇ keys to display data stored at higher or lower address numbers.



Delete the data

Deletes the selected data file.

Select [Delete the data] and press the MENU/ENTER key. The confirmation screen appears.

Use the Δ/∇ keys to select [Yes] and press the MENU/ENTER key.

Copy to the card (only internal memory data)

Copies the selected internal memory data file to the inserted SD memory card.

Select [Copy to the card] and press the MENU/ENTER key. The store name set screen appears.

Set the store name (number of four digits) at the copy destination and press the MENU/ENTER key.

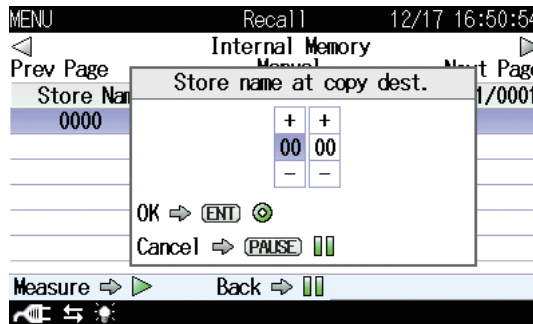

Cancel

Shuts the file processing screen.

Select [Cancel] and press the MENU/ENTER key.

MENU list items

System

Read/Save Setup File -----Load Default Settings
 Internal Memory---- List of setting groups on internal memory
 SD---- Startup File

Clock Settings

Backlight/LCD Settings -----Backlight Auto Off
 Backlight brightness
 LCD Auto Off (Auto Store)

Battery Type---- Alkaline / Ni-MH

Card Format

Index

Program Information -----Model, Version

Eco Setting

Store

Store Mode----Manual / Auto/ Timer Auto
 Manual----Store Name*2, Measurement Time
 Auto----Store Name, Total Measurement Time, Inst Store Interval,
 Calculation Interval
 Timer Auto----Store Name, Inst Store Interval, Calculation Interval,
 Timer Auto Start, Timer Auto Stop, Timer Auto Interval, Sleep Mode

Display / I/O

Timer-Level graph Time scale----20s, 1min, 2min
 Output -----Output OFF/ON
 Comparator -----OFF, 1, 2, 3, 4, 5, 6
 Communication Interface---- OFF, USB, RS-232C

Save

Screenshot(BMP)

Option

Measure (General)

Freq. Weighting for Acc. X-axis -----Wm, Wb, Wd, Non-Weighting
 Freq. Weighting for Acc. Y-axis -----Wm, Wb, Wd, Non-Weighting
 Freq. Weighting for Acc. Z-axis -----Wm, Wb, Wd, Non-Weighting
 Non-Weighting Freq. Band Freq. *3
 Lower limit---- 0.5Hz, 1Hz, 4Hz
 Upper limit---- 80Hz, 100Hz, 250Hz, Sensor dependent
 Freq. Range for Vel. and Disp. (Building Damage)
 Lower limit---- 0.5Hz, 1Hz, 4Hz
 Upper limit---- 80Hz, 100Hz, 250Hz, Sensor dependent
 Freq. Range for Vel. (Human Exposure)
 Lower limit---- 0.5Hz, 1Hz, 4Hz
 Upper limit---- 80Hz, 100Hz, 250Hz, Sensor dependent
 Dominant Frequency Line ---- No line, line1, line2, line3
 Delay Time--- OFF, 10s
 Standard---- General, SBR

Measure (SBR)

Freq. Range for Acc.
 Lower limit---- 0.5Hz, 1Hz, 4Hz
 Upper limit---- 80Hz, 100Hz, 250Hz, Sensor dependent
 Freq. range for Vel. and Disp. (Building Damage)
 Lower limit---- 1Hz *4
 Upper limit---- 100Hz *4
 Freq. range for Vel. (Human Exposure)
 Lower limit---- 1Hz *4
 Upper limit---- 80Hz *4
 Dominant Frequency Line ---- No line, line1, line2, line3
 Delay Time--- OFF, 10s
 Standard---- General, SBR

Recall

Recall data list

WR^{*5}

- *1: -----: Items displayed when proceeding to next menu level
- *2: When SD memory card is inserted
- *3: When Non-Weighting is selected in one of Freq. Weighting for Acc. X-axis, Y-axis, or Z-axis
- *4: SBR mode is a fixed value.
- *5: When optional VX-56WR is installed

Measurement

On this unit, PPV, VDV, and other values are calculated at one time. The calculation results are saved in an SD memory card. Via the Store menu, you can select the following three Store modes.

Manual mode

This mode allows calculation during a preset “Measurement Time.” Instantaneous values are not saved.

In Manual mode, the following measurement values are saved.

PPV, D.F., KBFmax (SBR: veff, max), Acc., MTVV, VDV, C.F., Disp., PVS, OVER / UNDER

In SBR mode, MTVV, VDV, C.F. measurement values are not saved.

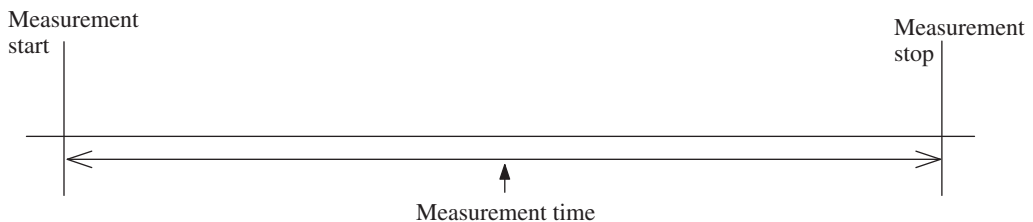

Auto mode

Calculation is performed at calculation intervals during a preset “Total Measurement Time.” At the same time, instantaneous values are saved every second.

In Auto mode, the following measurement values are saved.

PPV, D.F., KBFT (SBR: veff, max, 30), Acc., MTVV, VDV, C.F., Disp., PVS, OVER / UNDER

In SBR mode, MTVV, VDV, C.F. measurement values are not saved.

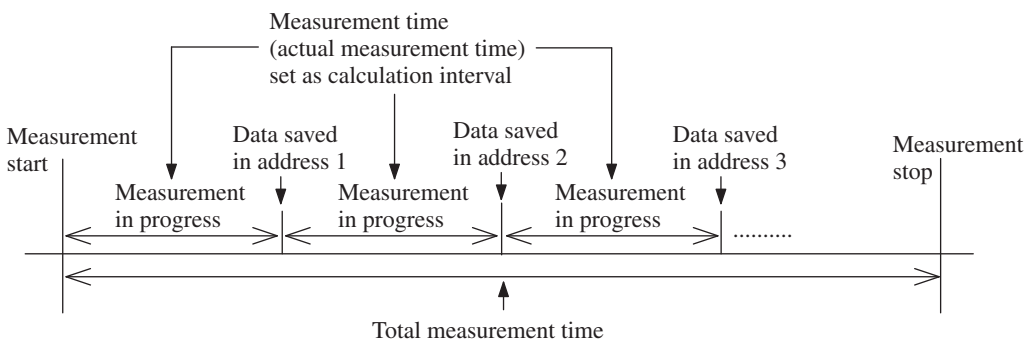

Operation if Level Trigger is on

When the preset trigger level is exceeded, measurement and store operation starts, including instantaneous values. When the level falls below the trigger level, measurement results according to the Total Measurement Time (TMT) setting are stored. At the point when TMT measurement data have been stored, if the current value has fallen below the threshold value, measurement stops and the unit enters the trigger standby condition. A Pretime longer than TMT cannot be set. The Delay time setting also becomes invalid.

If the Wave Rec Mode is ON (VX-56WR needs to be installed), WAVE files are also stored at the same time.

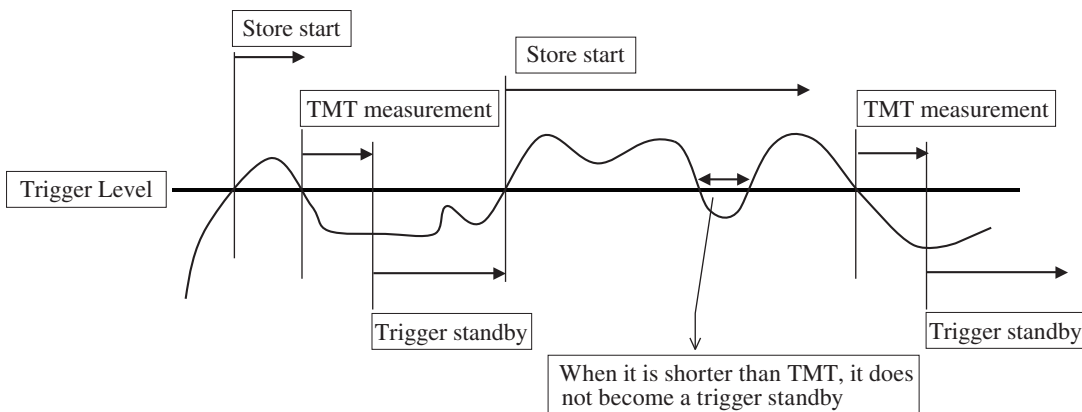

When Trigger Pretime is activated, Level Trigger will not be entered for the selected period after a measurement has been completed. (For example, if the pretime is set to 1, Level Trigger will not be entered for 1 second. If the setting is 5, Level Trigger will not be entered for 5 seconds.)

During this interval, store operation does not begin even if the trigger level is exceeded.

Timer Auto mode

With this mode, you can set the measurement start time and the measurement end time to perform measurement between these times. By setting a “Timer Auto Interval,” you can perform, for example, a 10-minute measurement every hour. At the same time, instantaneous values can be saved every second.

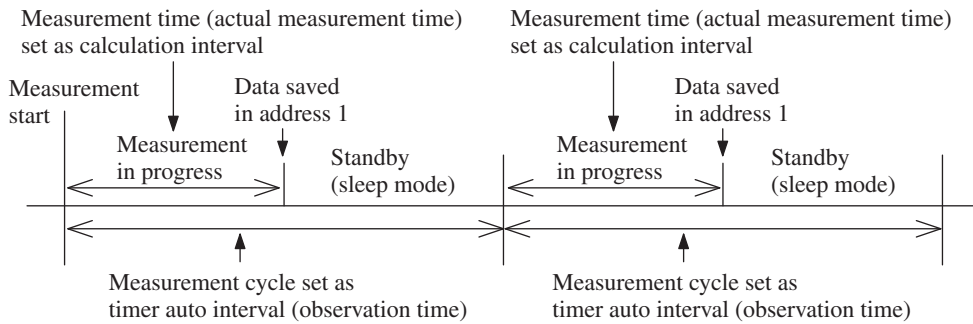

Note

If Sleep Mode is on, The KBFmax value is reset for each calculation cycle.

Measurement can not be started within 2 seconds after measurement is completed.

Procedure example of the measurement

- (1) Check that an SD memory card is inserted into the unit. Then, press the POWER key to start the unit.
- (2) Press the MENU/ENTER key. The menu list screen appears. As necessary, set the time and other parameters.
- (3) On the menu list screen, select the Store menu, and then set the Store modes. In addition, set a measurement time and other parameters on each Store mode.
- (4) Return to the current screen. As necessary, select the desired screen by using the display key and the X/Y/Z/XYZ keys.
- (5) Using the RANGE key, set ranges for the X-, Y-, and Z-axis.
- (6) To start measurement, press the START/STOP key. To end measurement, press the START/STOP key again.

Note
The delay of 2 seconds occurs from when vibration is measured until it is displayed.

Comparator

The comparator function compares the PPV (peak particle velocity) of the signal from the vibration pickup to a limit value that has been set previously. When the signal is equal to or higher than the limit value, an output (open collector circuit, LCD indication) is activated.

The comparator output is inactive during output calibration and while using a menu or the recall function. On the current screen, the function is always active, including during measurement, in measurement standby, and while not performing measurement (including pause mode).

During warm-up, in sleep mode, and while returning from sleep mode, the function is not active.

- Node Number

Specifies the number of polygonal line sections for setup.

- Limit Node

Specifies the PPV (0.05 mm/s to 100.00 mm/s) and Frequency (0.5 Hz to 315.0 Hz) parameters.

The range processed by the comparator extends from the frequency set for the lowest node to that of the highest node.

Excessive values detected outside this frequency range do not trigger comparator operation.

Frequencies lower than the frequency set for the lowest node cannot be specified.

Example: To achieve operation as shown in the diagram below, make the settings as follows.

Set “Node Number” to “4” and create Line 1 in accordance with DIN 4150-3.

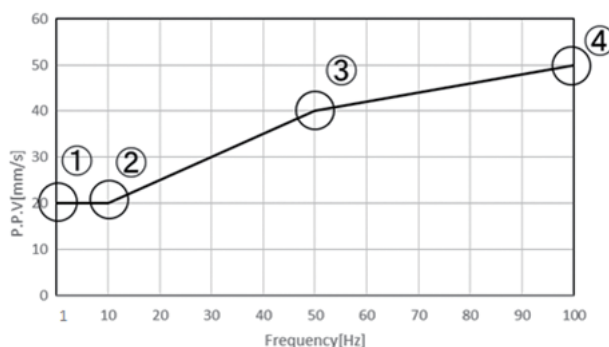

Set “Limit Node 1” to ①, “Limit Node 2” to ②, “Limit Node 3” to ③, and “Limit Node 4” to ④ as shown in the chart.

Node Number 4

Limit Node 1

Frequency 1.0 Hz

PPV 20.00 mm/s

Limit Node 2

Frequency 10.0 Hz

PPV 20.00 mm/s

Limit Node 3

Frequency 50.0 Hz

PPV 40.00 mm/s

Limit Node 4

Frequency 100.0 Hz

PPV 50.00 mm/s

⚠ Caution

In this example, detection of a dominant frequency of less than 1.0 Hz will not trigger comparator operation.

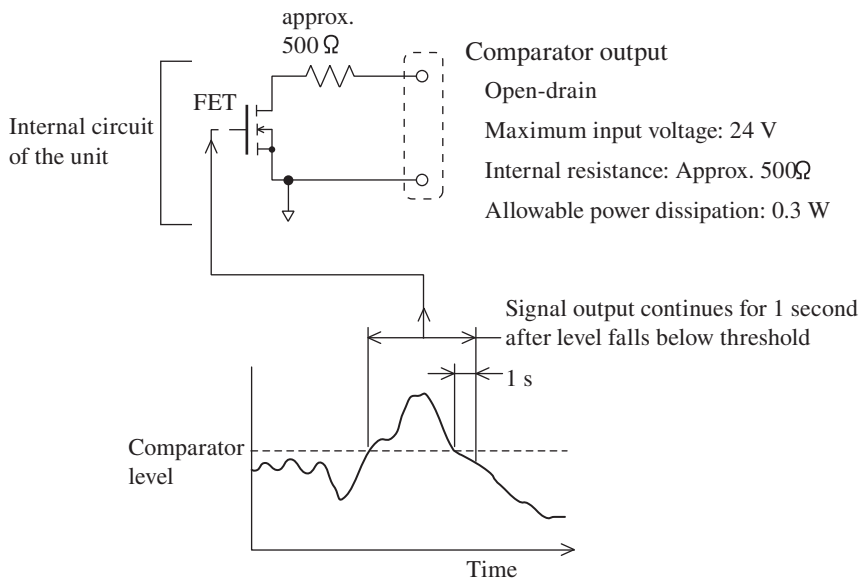

Store operation

About the store data format

Data stored on the SD memory card are in CSV format. Various files and subdirectories are created on the card.

The store name specified on the menu screen is created as a 4-digit number under the subdirectory name.

The file of one per one address is made.

VM-56

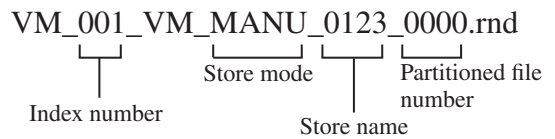
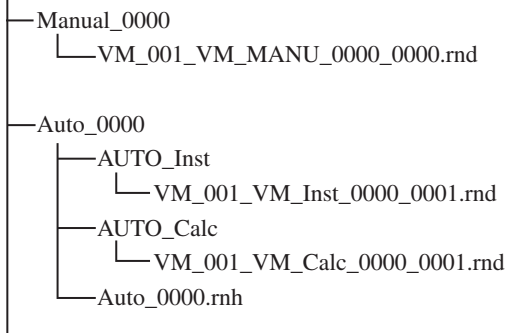

Store mode: The file name varies depending on the store mode.

Manual store: MANU

Auto store (Inst store): Inst.

Auto store (Calc store): Calc

Store name: 0000 to 9999

Partitioned file number:

Manual store is fixed to 0000

Note

The measurement date and time information shown in the recall menu is taken from the date/time when the respective folder was created. Note that the measurement date/time information displayed in the recall list may change when data were stored in a computer and then copied to an SD memory card. The measurement date/time information for individual data does not change.

About SD memory cards

The memory cards that can be used in this unit are SD memory cards. Be sure to use optional SD memory cards for VM-56 provided by Rion. SD memory cards even from the same manufacturer and of the same type exhibit certain variations in specifications which may cause problems. For this reason, be sure to use only the SD memory cards for VM-56 provided by Rion. The performance of other cards is not guaranteed.

An SD memory card inserted in the unit will be recognized as a removable disk by the computer when connected via USB, without having to install a USB driver.

To make the connection, use a generic USB cable (standard A male to mini B male connector). When not using the communication function, set the Communication Interface to OFF from the [Display / I/O] screen. When USB communication is enabled, a message requesting installation of a USB driver for USB communication will appear when the unit is connected to a computer.

Note
When using spreadsheet software or other programs on a computer to retrieve data from SD memory cards, some programs may not be able to read the original file names from the card. In such a case, rename the file using the extension “txt” (for example “VM_001_VM_MANU_0123_0000.txt”). For software that identifies files by the file name extension, set the software up for reading text files.
If measurement data in the SD memory card is moved to a computer and then moved back to VM-56, the measurement date (time stamp) may be different from the actual date.

Formatting an SD memory card

Note
When an SD memory card is formatted (initialized), all data present on the card will be lost. Never format an optional program card such as VX-56WR or VX-56RT with SD memory card formatting software (such as SD Formatter etc.). Otherwise the program data on the card will be erased and the program will become unusable. Recovery of erased programs is not guaranteed.

In the following cases, you should format the SD memory card:

- When using the SD memory card in the VM-56 for the first time
- When wishing to delete all data from the SD memory card

Note
Before using an SD memory card in this unit, formatting it in a computer is recommended. Formatting here refers to formatting the card while it is actually inserted in the computer. It does not refer to formatting the card from the computer while it is inserted in the VM-56 and recognized as a removable disk.

To format an SD memory card, proceed as follows.

1. Select [Card Format] on the [SYSTEM] screen and press the MENU/ENTER key.
2. The confirmation screen appears. Press the MENU/ENTER key.

Note
When formatting the SD memory card in a computer, select FAT or FAT32 as file system.

Screen hard copy

When you press the \triangleright key of $\triangle/\nabla/\triangleleft/\triangleright$ keys while holding down the DISPLAY key, the “Screenshot was saved to the card” message is displayed and the current screen contents will be saved as a bitmap file on the SD memory card.

Store target folder:	VM-56\Screenshot\
File name:	Time at which the file was stored
File name extension:	.BMP
Data capacity:	Approximately 300 kB per file

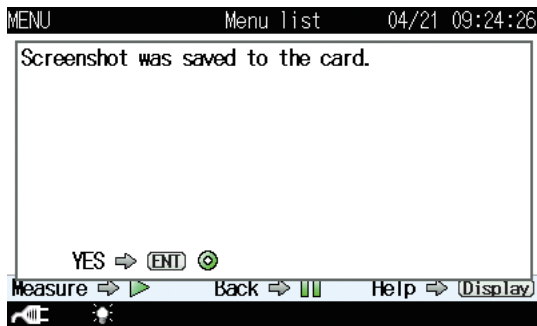

Card capacity and store time

The measurement duration for which data can be stored on an SD memory card depends on the capacity of the inserted card. Approximate times are listed below.

Using Auto store

Only Inst. store interval set

		SD memory card capacity		
Inst. store interval		512 MB	2 GB	32 GB
	100 ms	Approx. 155 hours	Approx. 606 hours	Approx. 9708 hours

Only Calculation store interval set

		SD memory card capacity		
Data sets		512 MB	2 GB	32 GB
		Approx. 8000 sets	Approx. 30000 sets	Approx. 50000 sets

Number of bytes per header file

About 1 kB per file

When performing waveform recording

Using Auto store, Inst. store interval 100 ms, measurement channel XYZ

		SD memory card capacity		
		512 MB	2 GB	32 GB
Bit length	16 bit	Approx. 8 hours	Approx. 32 hours	Approx. 698 hours
	24 bit	Approx. 5 hours	Approx. 22 hours	Approx. 394 hours

The duration of recording with 24 bit becomes shorter than that with 16 bit because the data volume of 24 bit is about 1.5 times more.

Output Connectors

OUTPUT connector

This turns the AC output signal ON/OFF and makes the settings for the signal.

1. Press the MENU/ENTER key to open the menu list screen.

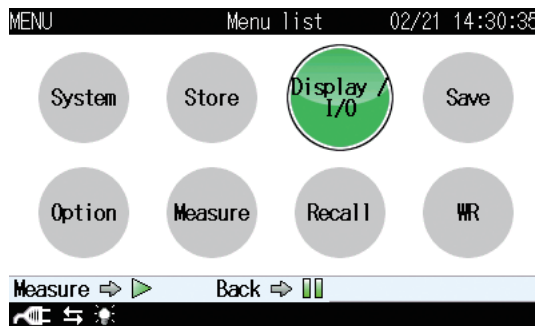

2. Select the Display / I/O menu.
3. Positioning the cursor on “Output,” press the MENU/ENTER key.

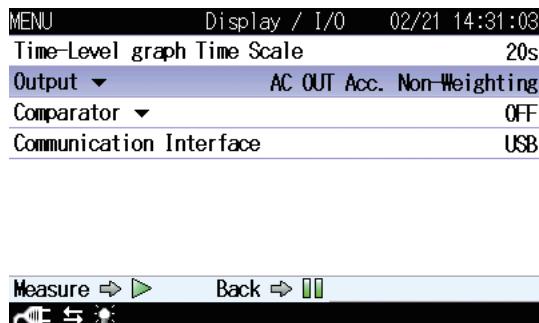

4. As necessary, switch “Output” ON/OFF. If you don’t need an AC output, select OFF. If you select ON, then follow steps 5 and 6 below.

MENU	Output	02/21 14:32:38
Output		ON
Quantity		Acc.
Freq.		Non-Weighting

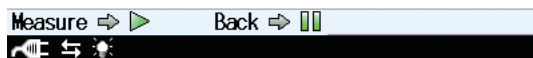

5. For “Quantity,” select between “Acc.” (Acceleration) and “Vel.” (Velocity).
6. To output the frequency-weighted signal, select “Weighted.” To output the non-frequency-weighted signal, select “not-Weighted.” To switch between output signals on the measurement screen, select “Interlock.” Below is a correspondence table between Measure setting and AC OUT setting.

Freq.	Measure setting	AC OUT
Interlock	Wb	Wb
	Wd	Wd
	Wm	Wm
	Non-Weighting	Non-Weighting
Non-Weighting	Wb	0.5Hz to 80Hz Band Limiting
	Wd	0.5Hz to 80Hz Band Limiting
	Wm	1Hz to 80Hz Band Limiting
	Non-Weighting	Non-Weighting
-	In any setting	"0.5Hz-Sensor Dependent Band Limiting"
Building Damage	Freq. Range for Vel. And Disp.(Building Damage)	Freq. Range for Vel. And Disp.(Building Damage) setting Band Limiting
Human Exposure	Freq. Range for Vel. (Human Exposure)	Freq. Range for Vel. (Human Exposure) setting Band Limiting

AC output characteristic

Output voltage:	1 Vrms (at Range Upper) at Acc. 0.1 Vrms (at Range Upper) at Vel.
Output impedance:	600 Ω
Load impedance:	10 k Ω or more
Suitable cable:	Output cord CC-24 (BNC - mini plug cable) The performance of other cables is not guaranteed.

The relationship between the display value shown by the unit and the output voltage is indicated below.

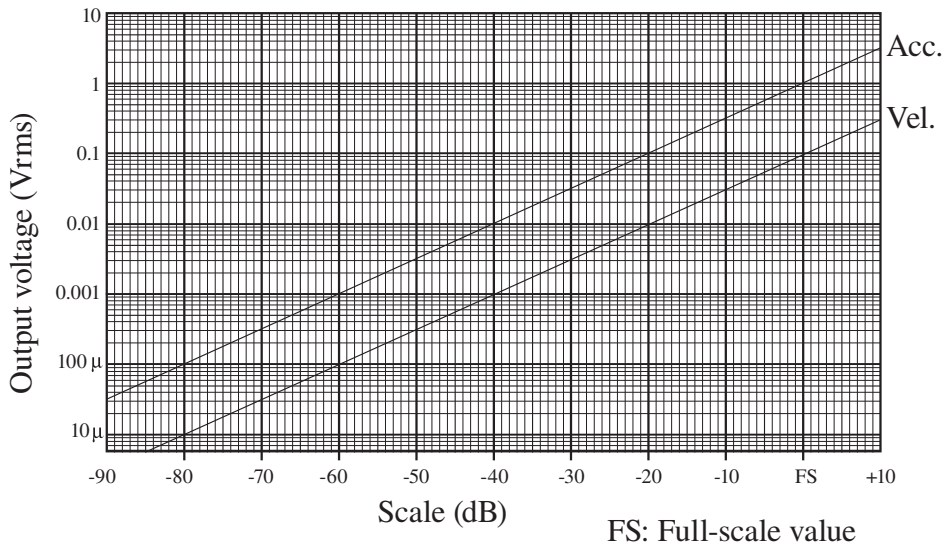

Ideal characteristics of the display value and the output voltage

Important

Using this feature will reduce battery life by about 25 percent.

Note

The full-scale value of “Vel.” is 20 dB smaller than “Acc.”, and the output voltage value of ACOUT is proportional.

Delay

The unit incorporates an A/D converter which converts the sensor input signal into digital format for processing by a DSP chip. The result is then returned to analog format by a D/A converter and output as an AC signal. Due to this process, the output signal has a constant delay time with regard to the sensor input signal. The delay time is about 0.55 ms in waveform recording, and about 1.1 ms in AC OUTPUT.

Default Settings

The factory default settings of the unit are listed below.

Displayed channel	Z axis
Range.....	0.001 m/s ² to 10 m/s ²
Backlight auto off	30 s
Backlight brightness	2
LCD auto off at auto store.....	OFF
Battery type	Alkaline
Index.....	1
Eco setting	OFF
Store mode.....	Manual
Store name	0000
Measurement time	10 min
Time scale of Time-Level graph	20 s
OUTPUT	AC OUT Acc. Interlock
Comparator	OFF
Communication interface	OFF
Baud rate.....	38400 bps
Flow control.....	OFF
Unit.....	OFF
Freq. weighting for Acc.....	Wm
Freq. Range for Vel. and Disp. (Building Damage)	1 Hz to 100 Hz
Freq. Range for Vel. (Human Exposure)	1 Hz to 80 Hz
Dominate Frequency Line.....	No Line
Delay time	OFF
Standard.....	General

When you turn power to the unit on while holding down the START/STOP key, the unit will be initialized to the above settings. When wishing to set the unit to the factory default values, select [Menu] → [System – Read/Save Setting] → [Load Default Settings] and then press the MENU/ENTER key (see page 82). The time, language and store data are not initialized.

Setup Files

Resume function

When power to the unit is turned on, the measurement screen appears. The settings active at this point are the same as were selected before the unit was last turned off (resume function).

Note

When the unit is started while a start up file exists on the inserted SD memory card, the start up file load function (see the following description) will be executed first.

Loading a start up file at startup

If a start up file exists on the inserted SD memory card, a selection screen such as shown at bottom will appear.

Selecting [Yes] at the screen will load the start up file.

Selecting [No] at the screen will cause the resume function to re-establish the same settings as before the last time the unit was turned off.

Refer to page 85 about setting of start up file.

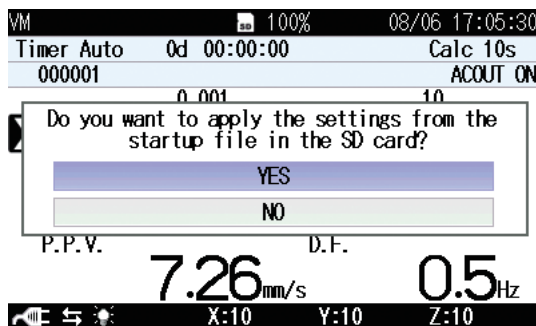

Restoring default settings (factory default settings)

Follow the steps below to restore the default settings.

1. Use the $\Delta/\nabla/\triangleleft/\triangleright$ keys to select [System] and press the MENU/ENTER key. The system screen appears.
2. Use the Δ/∇ keys to select [Read/Save setting] and press the MENU/ENTER key. The setting operation screen appears.
3. Use the Δ/∇ keys to select [Load Default Settings] and press the MENU/ENTER key. The confirmation screen appears.
4. Use the Δ/∇ keys to select [Yes] and press the MENU/ENTER key.

For information on items that will be default, see the “Default Settings” section on page 80.

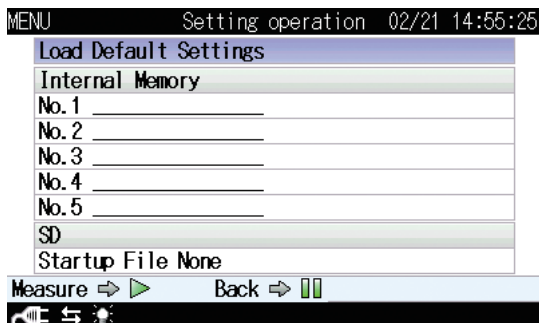

Setting operation screen

Using setup files

Setup files enable the following functions.

- Establish settings quickly and precisely by loading from a file prepared beforehand and stored on internal memory
- Return settings that were accidentally changed to the previous condition by loading from a file stored on internal memory

Setup files can be saved up to five in the internal memory of the unit.

Saving the current settings

1. Use the $\Delta/\nabla/\triangleleft/\triangleright$ keys to select [System] and press the MENU/ENTER key. The system screen appears.
2. Use the Δ/∇ keys to select [Read/Save setting] and press the MENU/ENTER key. The setting operation screen appears.
3. Use the Δ/∇ keys to select the desired number and press the MENU/ENTER key. The setting file processing screen appears.
4. Use the Δ/∇ keys to select [Save the setting] and press the MENU/ENTER key. The current settings is saved in the selected number. If there is already a setup file at the selected number, an overwrite confirmation screen appears. Use the Δ/∇ keys to select [Yes] and press the MENU/ENTER key.

Note

The recall screen settings are not saved. Only the settings of the immediately preceding measurement screen will be saved.

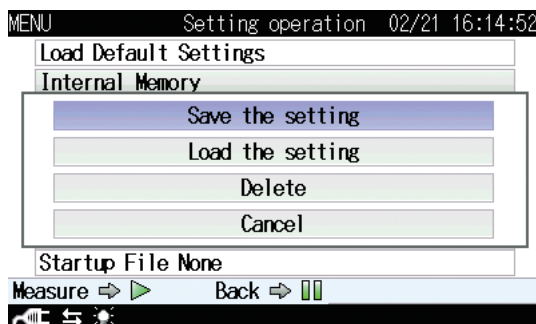

Setting file processing screen

Loading a setup file

Note
When you load settings from a file, the current settings will be overwritten. If necessary, you should save the current settings before loading a new set of settings.

1. Use the $\Delta/\nabla/\triangleleft/\triangleright$ keys to select [System] and press the MENU/ENTER key. The system screen appears.
2. Use the Δ/∇ keys to select [Read/Save setting] and press the MENU/ENTER key. The setting operation screen appears.
3. Use the Δ/∇ keys to select the desired number and press the MENU/ENTER key. The setting file processing screen appears.
4. Use the Δ/∇ keys to select [Load the setting] and press the MENU/ENTER key. The confirmation screen appears.
5. Use the Δ/∇ keys to select [Yes] and press the MENU/ENTER key. The file contents of the selected number will be reflected to the setting of the unit.

Deleting a setup file

1. Use the $\Delta/\nabla/\triangleleft/\triangleright$ keys to select [System] and press the MENU/ENTER key. The system screen appears.
2. Use the Δ/∇ keys to select [Read/Save setting] and press the MENU/ENTER key. The setting operation screen appears.
3. Use the Δ/∇ keys to select the desired number and press the MENU/ENTER key. The setting file processing screen appears.
4. Use the Δ/∇ keys to select [Delete] and press the MENU/ENTER key. The confirmation screen appears.
5. Use the Δ/∇ keys to select [Yes] and press the MENU/ENTER key. The file of selected number is deleted.

Setting a start up file

When a setting is saved in a start up file, the unit can be started using the setting.

1. Set the unit to the intended condition, so that measurement parameters and other settings are as desired.
2. Use the $\Delta/\nabla/\triangleleft/\triangleright$ keys to select [System] and press the MENU/ENTER key. The system screen appears.
3. Use the Δ/∇ keys to select [Read/Save setting] and press the MENU/ENTER key. The setting operation screen appears.
4. Use the Δ/∇ keys to select [Startup File None] of [SD] and press the MENU/ENTER key. The [Save the setting]/[Cancel] selecting screen appears.

Note

When a start up file has already been saved, select [Startup File Exist].

5. Use the Δ/∇ keys to select [Save the setting] and press the MENU/ENTER key. When “The setting was saved” is displayed, it means that the saving process has been completed.

Note

When selecting [Startup File Exist] to overwrite the data, select [Yes] on the confirmation screen.

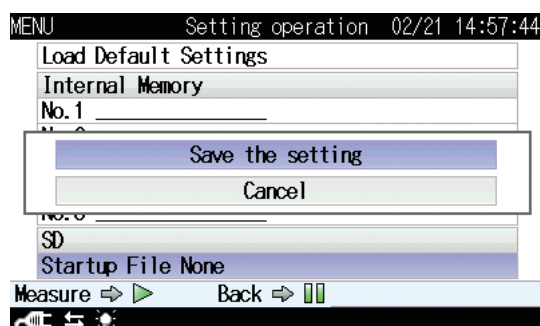
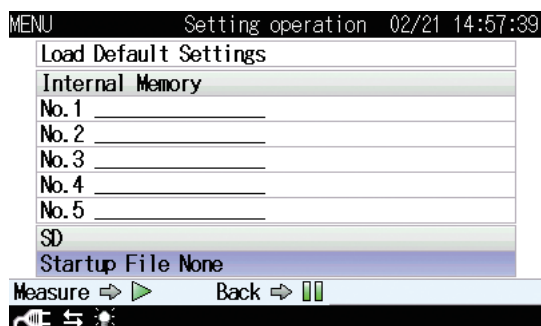

Optional Accessories

Extension cord

If the vibration pickup is to be positioned at a distance from the main unit, you can use the following extension cord(s).

Type	Length
EC-04A	5 m
EC-04B	10 m
EC-04C	30 m (with reel) + 5 m (Relay code)
EC-04D	50 m (with reel) + 5 m (Relay code)
EC-04E	100 m (with reel) + 5 m (Relay code)

The 30 m, 50 m, and 100 m cable is supplied on a reel.

Extension cords with reels can be joined.

* Extension cords without reel cannot be joined.

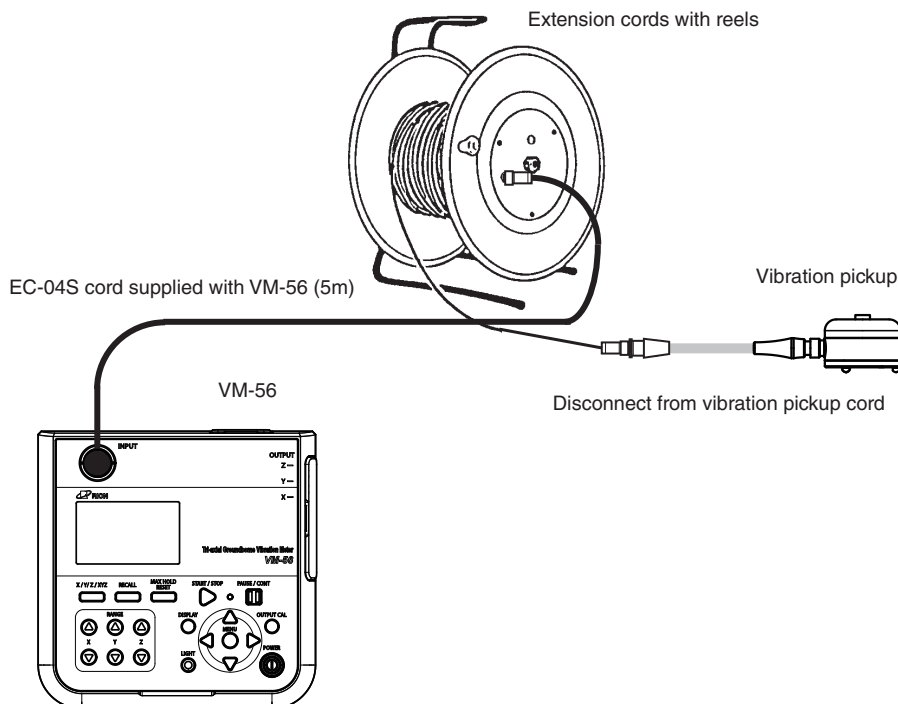

Precautions for using extension cord with reel

Important

When installing or dismantling a system, always make sure that all connection cords are disconnected from the cord reel. Otherwise cord breaks due to twisting may occur.

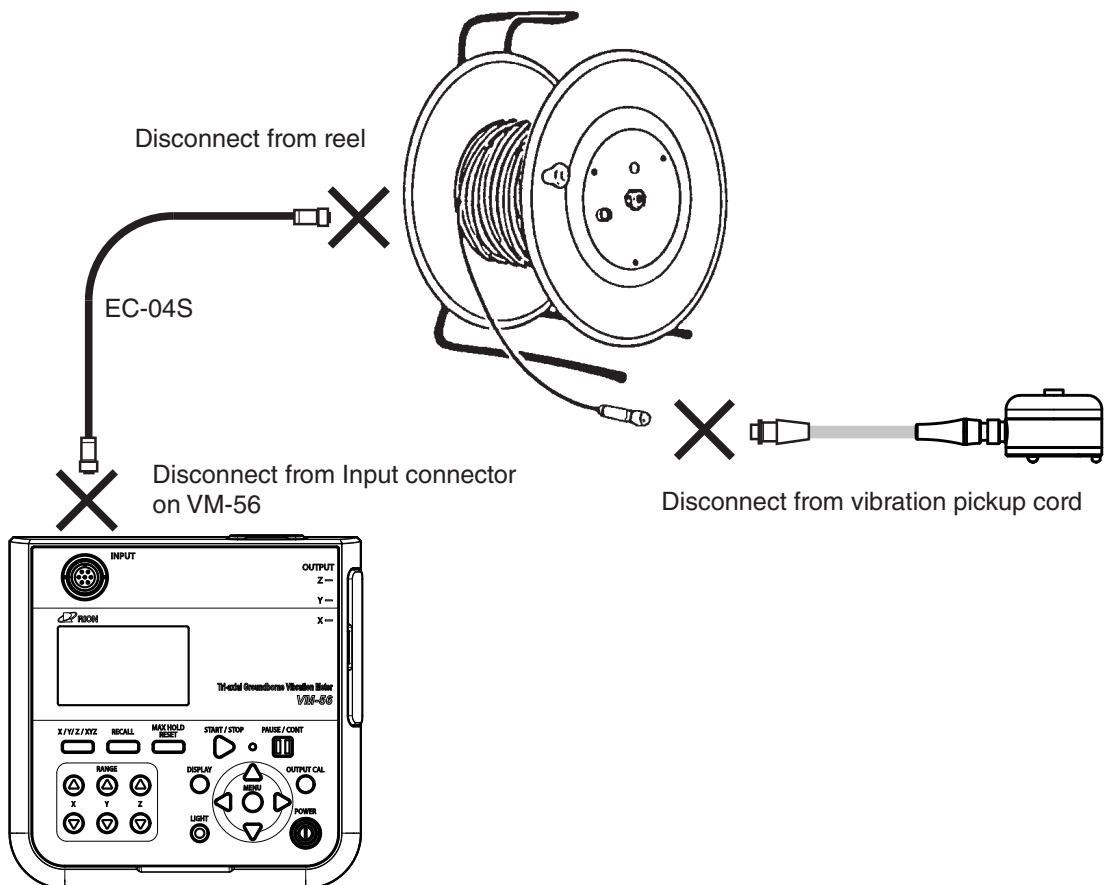

DIN plate VP-54D / L-bracket (for wall mounting)VP-54L installation

DIN plate VP-54D installation

Remove the three small feet from the PV-83D.

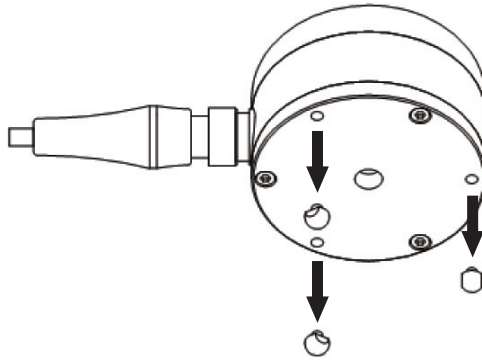

* Take care not to lose these small parts.

Use the three holes of the PV-83D feet to mount the DIN plate using screws (see illustration [1] below). The DIN plate feet are reversible, with a spike feet and a round feet. Select the suitable type for the intended use (see illustration [2] below).

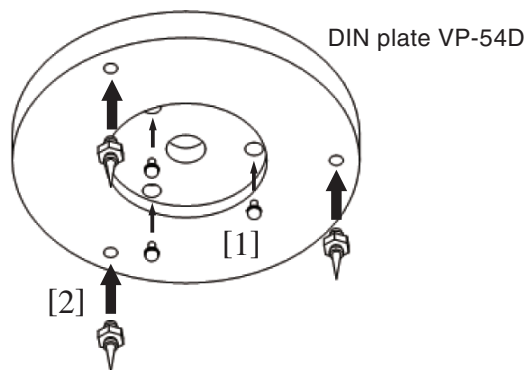

* Take care not to hurt yourself with the spikes.

Spike feet	When mounting transducers on soft surfaces such as carpets or floor coverings Ex : Mounting on the ground
Round feet	When transducers are loosely placed on hard surfaces Ex : Hard surfaces include the building, foundation, walls, pavement, machine surfaces, hard floors, and window or door reveals. * Refer to DIN 45669-2

L-bracket VP-54L installation

Remove the three small feet from the PV-83D.

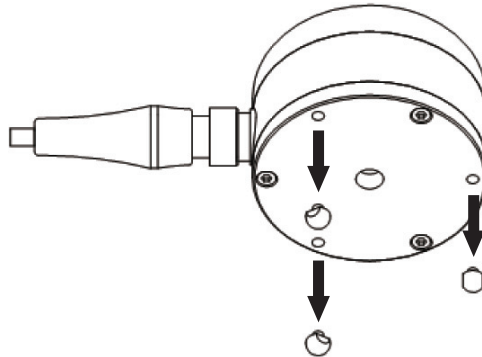

* Take care not to lose these small parts.

Mount the L-bracket to a wall using anchors (3-point mounting shown in the illustration).

When mounting the VP-54L to a wall, align it to the Z axis.

When aligning to the gravitational acceleration direction, use the level gauge on top of the PV-83D as a reference. Depending on the condition of the surface to which the bracket is to be mounted, several anchors may need to be used for securing the bracket. To prevent unwanted rotation, fastening with three or four anchors is recommended (see illustration).

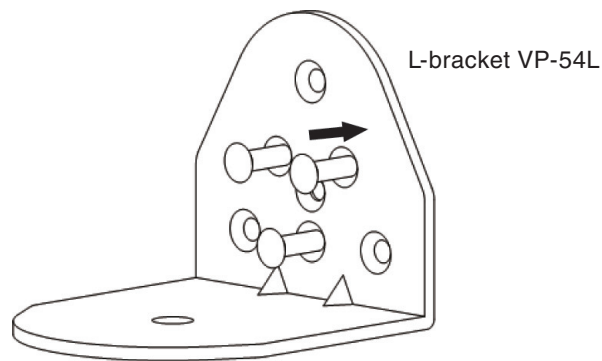

Screw-mount the PV-83D to the L-bracket with the required X and Y axis orientation.

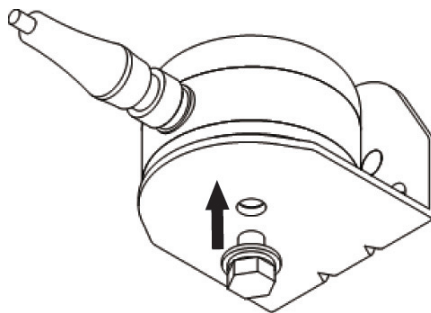

Serial Interface

The VM-56 incorporate a serial interface. This interface allows the use of a computer to make measurement parameter settings and to control the measurement. It is also possible to send measurement results (current results as well as data stored in the memory of the VM-56) to the computer for further processing.

Standard terminal software (Hyper Terminal, etc.) can also be used as communication client.

RS-232C

Connection to a computer

Connect the I/O connector on the right side of the VM-56 with a RS-232C connector of a computer, using the optional RS-232C serial I/O cable CC-42R as shown below. The performance of other cables will not be guaranteed.

Note that the performance of multiple units connection with RS-232C will not be guaranteed.

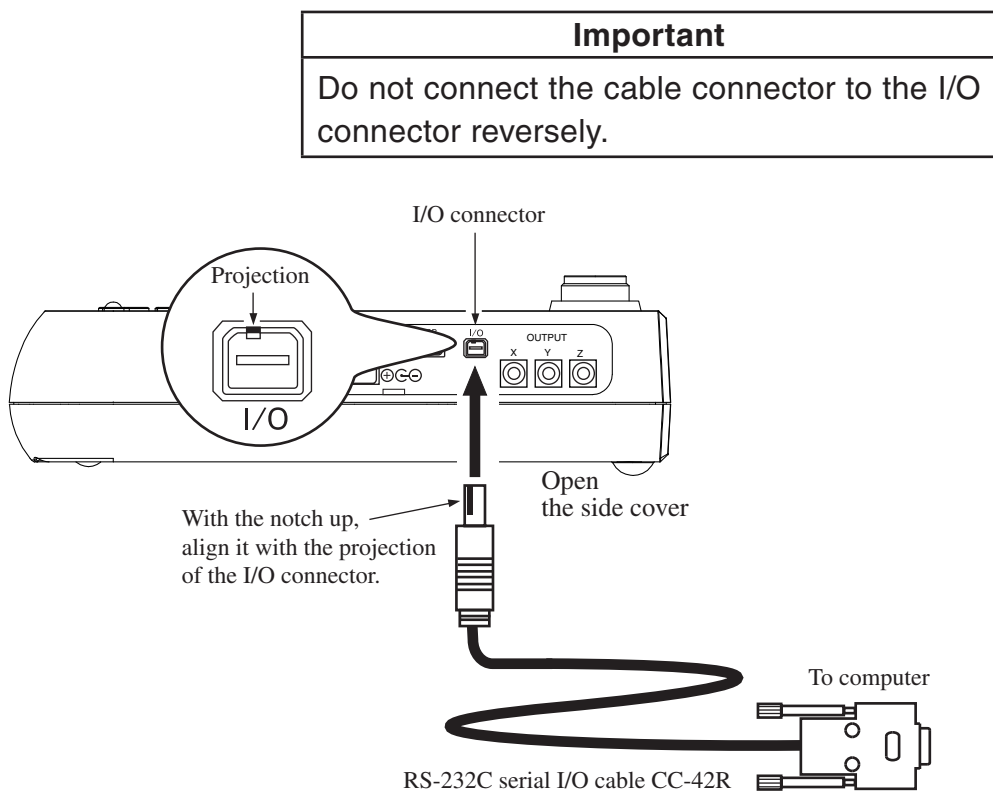

Setting of the VM-56 when using the RS-232C

When using RS-232C, set the communication interface for the VM-56 following the steps below.

1. Press the MENU/ENTER key to bring up the menu list screen.
2. Use the $\triangle/\nabla/\triangleleft/\triangleright$ keys to select [Display / I/O] and press the MENU/ENTER key. The display / I/O screen appears.
3. Use the \triangle/∇ keys to select [Communication Interface] and press the MENU/ENTER key. The communication control function screen appears.
4. Use the \triangle/∇ keys to select [RS-232C] and press the MENU/ENTER key.
5. Select the [Baud rate] on the display / I/O screen and press the MENU/ENTER key. The baud rate screen appears.
6. Use the \triangle/∇ keys to select baud rate (38400 bps, 57600 bps, 115200 bps) and press the MENU/ENTER key.
7. Select the [Flow control] on the display / I/O screen and press the MENU/ENTER key. The flow control screen appears.
8. Use the \triangle/∇ keys to select flow control (OFF, HARD, SOFT) and press the MENU/ENTER key.
9. Press the START/STOP key to return to the measurement screen.

The CC-42R serial I/O cable uses a 9-pin connector (female).
The cable is optional.

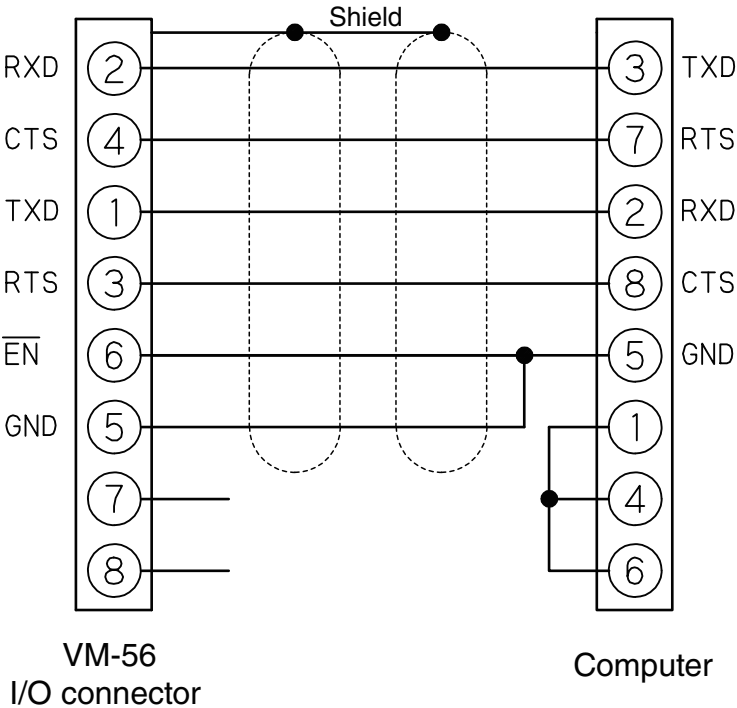

Note
When VM-56 is connected to a computer, the minimum measurement level of VM-56 may rise by the noise from a computer.

Transfer protocol

- Transfer principle: full duplex
- Sync principle: asynchronous
- Baud rate: 38400 / 57600 / 115200 bps
- Data word length: 8 bit
- Stop bits: 1 bit
- Parity check: none
- Flow control: OFF / HARD / SOFT

USB

About USB

The VM-56 can use a USB connection for operation control and transfer of data. To use the USB interface, a USB driver must be installed on the computer. Please download USB driver from our web site (<https://rion-sv.com/>). Installation and operation procedures are explained in this manual. Note that the performance of multiple units connection with USB will not be guaranteed.

Operating environment

Supported Operating Systems

- Microsoft Windows 7 Professional (32 bit/64 bit*)
 - * The update by security program of Microsoft Windows (KB3033929) is necessary to 64 bit Windows 7.
Please refer to [Control Panel]-[Programs and Features]-[View installed updates] of the computer for confirmation of the update.
- Microsoft Windows 8.1 Pro (32 bit/64 bit)
- Microsoft Windows 10 Pro (32 bit/64 bit)

Installing the USB driver

By connecting the VM-56 to a computer with a USB cable, the VM-56 can be controlled remotely from the computer, and measurement data can be sent to the computer in real time. To enable use of these functions, you must first download driver software from the RION Corporation web site and install this driver on the computer to be used with the VM-56. The driver will create a virtual COM port on the computer.

Installation procedure

When connecting the VM-56 and the computer for the first time, install the USB driver as follows.

1. Download the latest USB driver from the RION CO., LTD. web site (<https://rion-sv.com/>).

When using 32 bit OS, execute the file “setup.exe” located in the “installer_x86” folder.

When using 64 bit OS, execute the file “setup.exe” located in the “installer_x64” folder.

The installation starts.

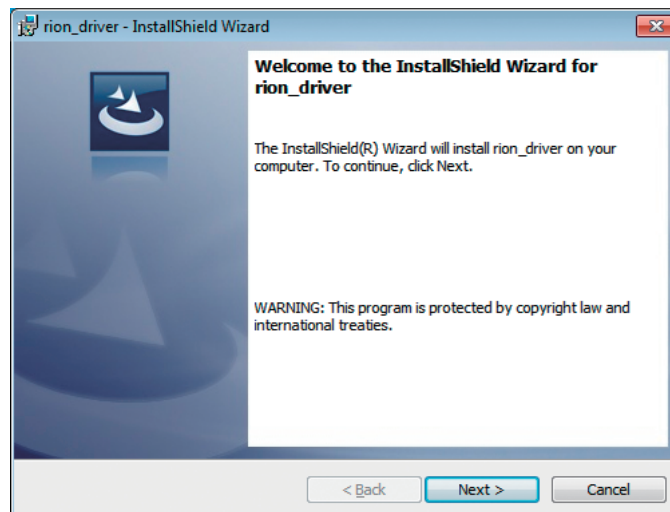

Follow the wizard to complete the installation.
Screens during installation are as follows.

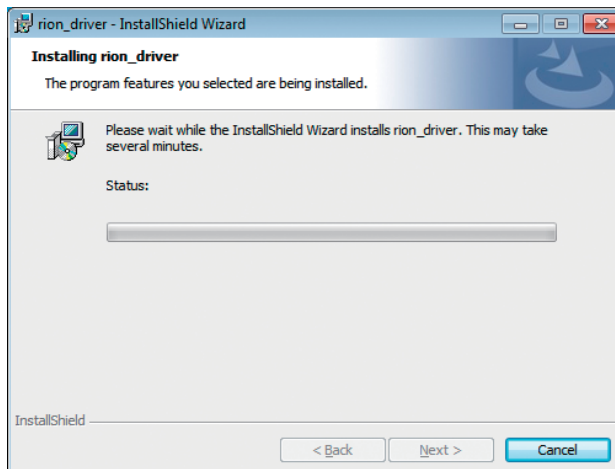
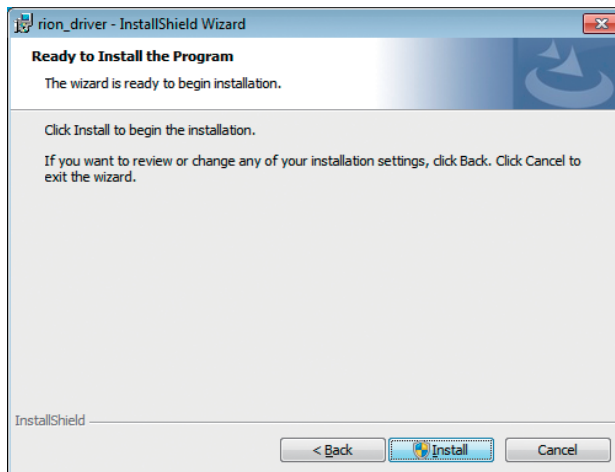
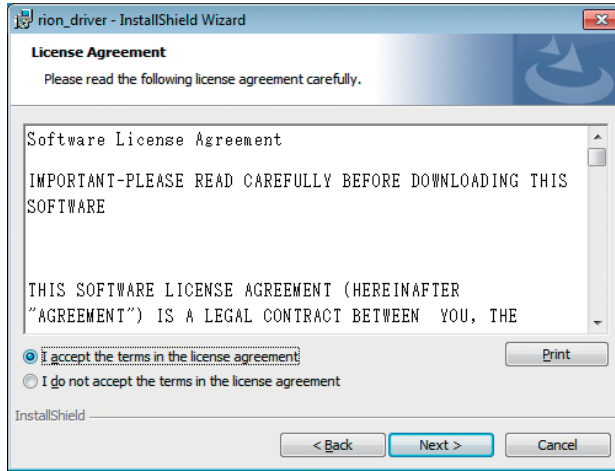

Depending on your environment, [Windows Security] may be displayed. Click on “Install” or “Continue”.

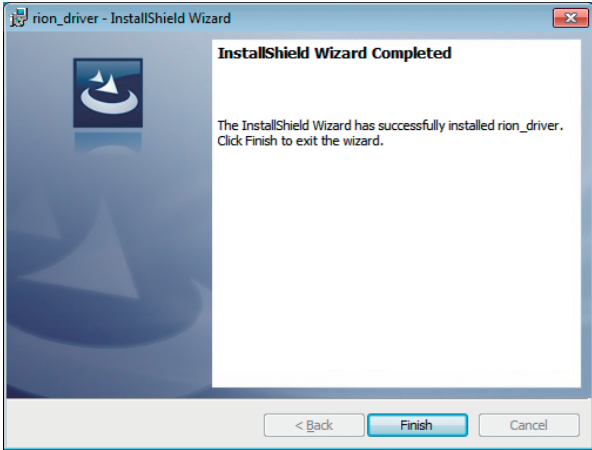
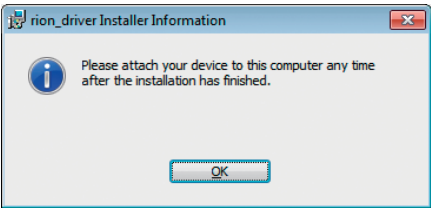
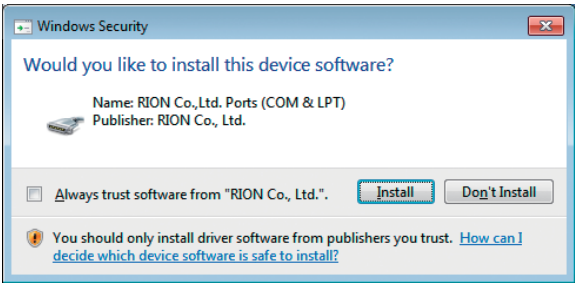

2. Turn power to the VM-56 on, select [Display / I/O] and set [Communication Interface] to “USB”.

Important
The above steps must be completed before connecting the USB cable.

3. Connect the VM-56 to the computer with a USB cable (see page 94).

Important
Connect the VM-56 directly with the USB cable to the computer. If the VM-56 is connected via a USB hub, normal operation is not assured.

When the computer detects the VM-56, the device driver software installation is started automatically. When the installation has been completed, USB communication is enabled.

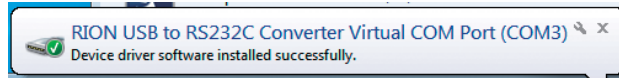

The driver installation creates a virtual COM port in the computer. For information on how to verify that the installation was successful, see the section “Checking the virtual COM port” on next page.

Checking the virtual COM port

1. After installing the driver, set [Communication Interface] to “USB” at the VM-56 and connect the USB cable.
2. Open the Device Manager (“Hardware” tab under “Properties” in My Computer).

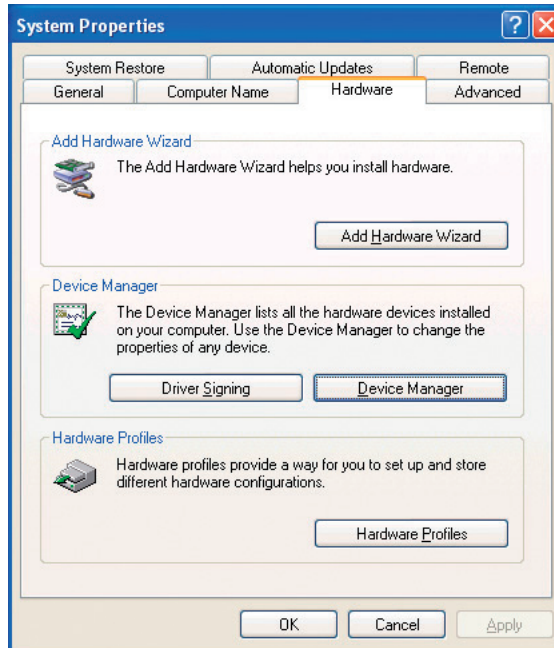

3. Click on the + at the left of “Ports (COM & LPT)”.

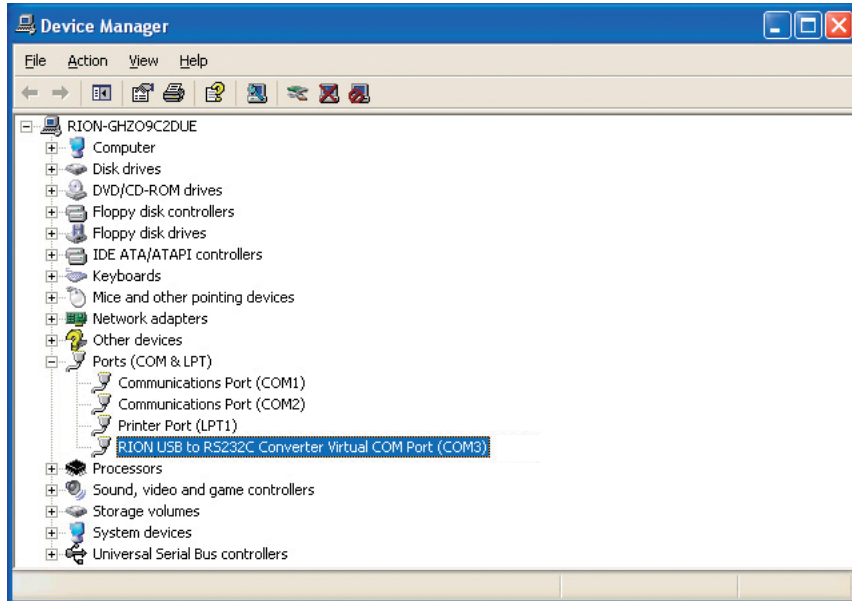

The indication “RION USB to RS232C Converter Virtual COM Port” should be shown as COM port name. If this is not shown, check the connection between the VM-56 and the computer (step 1). If there is an “x” over the icon, the port is not functioning normally. Install the driver again.

Connection to a computer

Connect the USB connector on the bottom of the VM-56 with a USB connector of a computer, using the optional (generic) A - mini B USB cable as shown below.

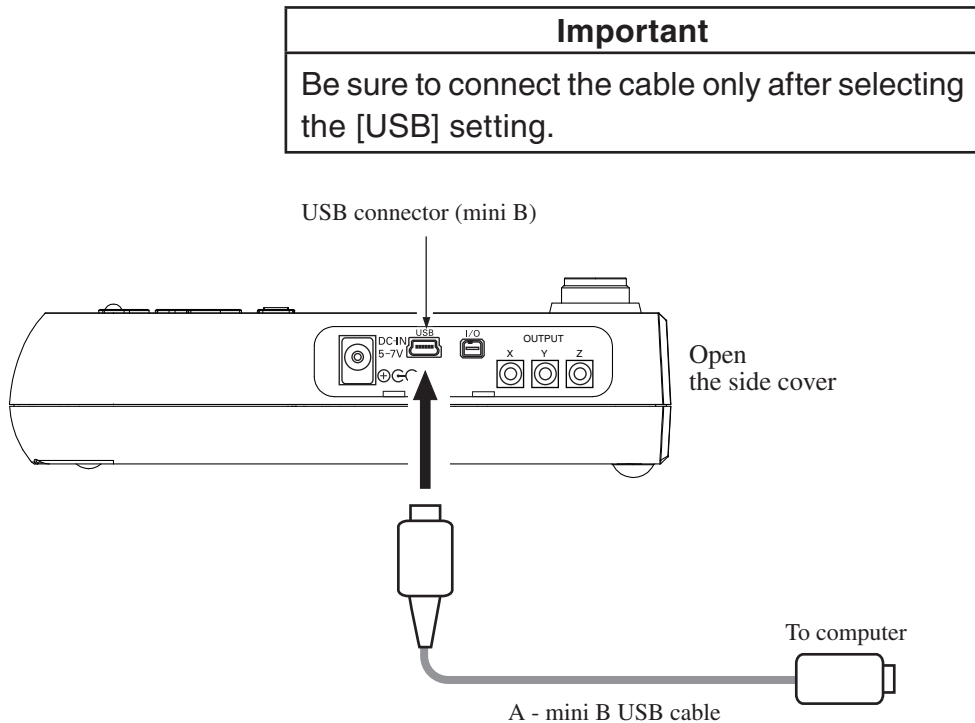

Setting of the VM-56 when using the USB

When using USB, set the communication interface for the VM-56 following the steps below.

1. Press the MENU/ENTER key to bring up the menu list screen.
2. Use the $\Delta/\nabla/\triangleleft/\triangleright$ keys to select [Display / I/O] and press the MENU/ENTER key. The display / I/O screen appears.
3. Use the Δ/∇ keys to select [Communication Interface] and press the MENU/ENTER key. The communication control function screen appears.
4. Use the Δ/∇ keys to select [USB] and press the MENU/ENTER key.
5. Press the START/STOP key to return to the measurement screen.

Disconnection from the computer

VM-56 will be recognized as “removable media”. Consequently, the correct procedure as described below must be followed when disconnecting the VM-56.

1. Click on the “Safely remove hardware” icon in the right section of the taskbar, and select “Safely remove USB Mass Storage Device - Drive (*1)”.

*1: The drive letter (E in the example shown) will differ, depending on the computer configuration.



2. When the message shown below appears, disconnect the USB cable.



The VM-56 is now properly disconnected.

Communication cutoff

Sleep mode

When sleep mode is enabled, the unit enters the sleep state after the current block has been sent. In the sleep state, the VM-56 does not send or accept commands.

ECO setting

When ECO setting is selected, it will be enabled after a transmission of current command is completed. After that, the VM-56 does not send or accept commands (ECO setting disables the communication control function).

Power off

During power off processing, communication is terminated after the current command was sent.

Auto shutdown

Same as power off.

Rated values

Guaranteed values

Case	Rated Values	Remarks
VM-56 response time	Max. 3 s	Result code 0004 (state error) response if due to processing reasons
Send character interval	Max. 100 ms	–
Interval until VM-56 enters idling state after sending data	Max. 200 ms	After receiving data from the VM-56, wait at least 200 ms before sending the next command (For DOD?, at least 1 s)

Rated values

Case	Rated Values	Remarks
Receive character interval timeout	No limit	–

Command

Command types

There are two types of commands: setting commands and request commands.

Setting command

This type of command serves for changing the VM-56 status or measurement parameters. Only some commands of this type will produce a response from the VM-56. The response consists of status information returned after the setting command has been processed.

Request command

This type of command serves for getting information about unit settings and for obtaining measurement data including display data and stored data. The VM-56 returns the requested data.

Command format

Setting command

Command = "\$" + "command name" + "," + "parameter" + [CR] + [LF]

The basic components of a setting command are the command name and the parameter. "\$" at the beginning represents the processing state of the command and is automatically displayed. During the processing of the command, "\$" is not displayed and does not accept the command input. A comma is used as delimiter between the command name and parameter, and the setting command is terminated by a [CR]+[LF] (carriage return + line feed). The setting command uses the CSV format.

Prohibited items of setting command

- Spaces in a command name may not be omitted.
- Spaces in a command name may not be doubled.
- The "," (comma) after the command name may not be omitted.
- Japanese full-width characters are not allowed.

Result code

This is a response data that indicates execution results of commands. The structure of a result code is shown below.

Result code = “R+” + “four-digit number”

The four-digit number following the prefix character “R+” indicates the situations described below.

Numbers	Contents
0000	Normal end This is a response to the situation where the command (setting or request) is executed normally.
0001	Command error This is a response to the situation where the specified command cannot be recognized.
0002	Parameter error This is a response to the situation where the number of parameters and the parameter type allowed for the specified command are not met.
0003	Designation error This is a response to the situation where a setting is made with a command which can only handle requests, or a request is made with a command which can only handle settings.
0004	Status error This is a response to the situation where the command (setting or request) cannot be executed in a current situation.

Transfer codes

The codes (control codes) used for communication with the VM-56 are as follows.

Code	Hex notation	Meaning
[CR]	0DH	Terminator, (1st character)
[LF]	0AH	Terminator, (2nd character)
[SUB]	1AH	Stop request

Command list

S: Setting command (command for making a VM-56 setting)

R: Request command (command for obtaining status information or measurement data from VM-56)

Communication

Command	Function	See page
Echo	Echo back (S/R)	114
Remote Control	Remote mode (S/R)	114

System

Command	Function	See page
System Version	System version information (R).....	115
Clock	Current date and time (S/R).....	115
Calibration	Calibration (S/R).....	116
Index Number	Index number (S/R)	116
Key Lock	Key lock (S/R)	116
Backlight	Backlight (S/R)	117
Backlight Auto Off	Backlight auto off (S/R)	117
Load Default Factory Settings	Load default factory settings (S)	117
LCD	LCD (S/R).....	118
LCD Auto Off	LCD auto off (S/R).....	118
Backlight Brightness	Backlight brightness (S/R).....	118
Battery Type	Battery type (S/R)	119
SD Card Total Size	SD memory card capacity (R)	119
SD Card Free Size	SD memory card free space (R)	119
SD Card Percentage	SD memory card free space percentage (R)	119

Display, performance

Command	Function	See page
Time Level Time Scale	Time scale of time-level display (S/R)	120
Range X	Xch range upper limit (S/R)	120
Range Y	Ych range upper limit (S/R)	120
Range Z	Zch range upper limit (S/R)	121

Display Channel Setting	Display channel setting (S/R)	121
Max Hold Reset	Max hold reset (S).....	121

I/O

Command	Function	See page
OUTPUT	Output setting (S/R)	122
OUTPUT Quantity	Output quantity (S/R).....	122
OUTPUT Band	Output frequency characteristic (S/R)	123
Comparator Node Number	Comparator node number (S/R)	123
Comparator Node"x" Frequency	Comparator node frequency (S/R).	124
Comparator Node"x" PPV	Comparator node PPV (S/R)	124
Communication Interface	Communication interface (S/R).....	124
Baud Rate	RS-232C baud rate (S/R)	125
Communication Flow	RS-232C communication flow (S/R)	125

Store

Command	Function	See page
Store Mode	Store mode (S/R)	126
Store Name	Store name (S/R)	126
Inst Store Interval	Inst store interval (S/R).....	126
Calculation Interval Preset	Calculation interval (S/R).....	127
Calculation Interval (Num)	Calculation interval of user setting (number) (S/R).....	127
Calculation Interval (Unit)	Calculation interval of user setting (unit) (S/R).....	128
Measurement Time Preset Manual	Measurement time of manual store (S/R)	128
Measurement Time Manual (Num)	Measurement time of user setting on manual store (number) (S/R)	129

Measurement Time Manual (Unit)	Measurement time of user setting on manual store (unit) (S/R)	129
Measurement Time Preset Auto	Total measurement time of auto store (S/R)	130
Measurement Time Auto (Num)	Total measurement time of user setting on auto store (number) (S/R)	130
Measurement Time Auto (Unit)	Total measurement time of user setting on auto store (unit) (S/R).....	131
Timer Auto Start Time	Timer auto start time (S/R)	131
Timer Auto Stop Time	Timer auto stop time (S/R)	132
Timer Auto Interval	Timer auto measurement interval (S/R)	132
Sleep Mode	Sleep mode (S/R).....	133
Manual Address	Manual store address (S/R).....	133
Measure	Measurement (S/R)	133
Pause	Pause (S/R).....	134
Manual Store	Manual store (S/R)	134
Measurement Start Time	Measurement (operation) start time (R).....	134
Measurement Stop Time	Measurement (operation) stop time (R).....	135
Measurement Elapsed Time	Measurement elapsed time (R)	135

Measurement

Command	Function	See page
Acc Weighted X	Frequency weighting of X-axis for acceleration (S/R).....	135
Acc Weighted Y	Frequency weighting of Y-axis for acceleration (S/R).....	136
Acc Weighted Z	Frequency weighting of Z-axis for acceleration (S/R).....	136

Acc Lower	Frequency weighting of Acc lower (S/R).....	137
Acc Upper	Frequency weighting of Acc upper (S/R).....	137
Vel Disp Build Lower	Frequency weighting of building Vel and Disp lower (S/R).....	137
Vel Disp Build Upper	Frequency weighting of building Vel and Disp upper (S/R).....	138
Vel Human Lower	Frequency weighting of human Vel lower (S/R)	138
Vel Human Upper	Frequency weighting of human Vel upper (S/R)	139
Dominant Frequency Line	Determine for dominant frequency line (S/R).....	139
SBR Acc Lower	Frequency weighting of Acc lower (SBR Mode) (S/R)	140
SBR Acc Upper	Frequency weighting of Acc upper (SBR Mode) (S/R)	140
SBR Dominant Frequency Line	Determine for dominant frequency line (SBR Mode) (S/R).....	141
Delay Time	Delay time (S/R).....	141

Operation

Command	Function	See page
Underrange Inst X	Xch underrange Inst (R)	142
Underrange Calc X	Xch underrange Calc (R).....	142
Overload Inst X	Xch overload Inst (R).....	142
Overload Calc X	Xch overload Calc (R)	143
Underrange Inst Y	Ych underrange Inst (R)	143
Underrange Calc Y	Ych underrange Calc (R)	143
Overload Inst Y	Ych overload Inst (R)	144
Overload Calc Y	Ych overload Calc (R).....	144

Underrange Inst Z	Zch underrange Inst (R)	144
Underrange Calc Z	Zch underrange Calc (R))	145
Overload Inst Z	Zch overload Inst (R)	145
Overload Calc Z	Zch overload Calc (R).....	145

Data output

Command	Function	See page
DOD	Output displayed value (R)	146
DOD Calc	Output calculation value (R)	147
DRD	Continuous output (R)	149

Command description

Communication

Echo

Echo back

Setting ON/OFF of echo back

Setting command Echo, p1

Parameter p1= "Off"
p1= "On"

Request command Echo?

Response data d1

Returned value Same as for setting command

Remote Control

Remote mode

Setting ON/OFF of remote mode

When remote mode is "On", the key operation of the unit is invalid (only the POWER key and the LIGHT key are effective). When remote mode is "Off", the key operation of the unit is valid.

Setting command Remote _ Control, p1

Parameter p1= "Off" (Remote mode is OFF)
p1= "On" (Remote mode is ON)

Request command Remote _ Control?

Response data d1

Returned value Same as for setting command

System

System Version

System version information

Request system version information

Request command System _ Version?p1

Parameter p1= "VM"

p1= "WR"

p1= "RT"

Response data d1= "x.x" (x is 0 to 9)

There is no setting command

When the parameter p1 is omitted, the request command means "System _ Version?VM"

Clock

Current date and time

Setting current date and time

Setting command Clock, p1/p2/p3 _ p4:p5:p6

Parameter p1= 2018 or after (year)

p2= 1 to 12 (month)

p3= 1 to 31 (date)

p4= 0 to 23 (hour)

p5= 0 to 59 (minute)

p6= 0 to 59 (second)

Request command Clock?

Response data d1/d2/d3 _ d4:d5:d6

Returned value Same as for setting command

Calibration

Calibration

Transition to calibration state

Setting command	Calibration, p1
Parameter	p1= "Off" p1= "On"
Request command	Calibration?
Response data	d1
Returned value	Same as for setting command

Index Number

Index number

Setting index number

Setting command	Index _ Number, p1
Parameter	p1= 1 to 255
Request command	Index _ Number?
Response data	d1
Returned value	Same as for setting command

Key Lock

Key lock

Setting ON/OFF of key lock

Setting command	Key _ Lock, p1
Parameter	p1= "Off" p1= "On"
Request command	Key _ Lock?
Response data	d1
Returned value	Same as for setting command

Backlight

Backlight

Setting ON/OFF of backlight

Setting command	Backlight, p1
Parameter	p1= "Off" p1= "On"
Request command	Backlight?
Response data	d1
Returned value	Same as for setting command

Backlight Auto Off

Backlight auto off

Setting time of backlight auto off

Setting command	Backlight _ Auto _ Off, p1
Parameter	p1= "Short" (30 seconds) p1= "Long" (3 minutes) p1= "Cont" (continue)
Request command	Backlight _ Auto _ Off?
Response data	d1
Returned value	Same as for setting command

Load Default Factory Settings

Load default factory settings

Setting On/OFF of Load _ default _ factory _ settings

Setting command	Load default factory settings, p1
Parameter	p1= "Off" p1= "On"
Response data	d1
Returned value	Same as for setting command

LCD

LCD

Setting ON/OFF of LCD

Setting command	LCD, p1
Parameter	p1= "Off" p1= "On"
Request command	LCD?
Response data	d1
Returned value	Same as for setting command

LCD Auto Off

LCD auto off

Setting time of LCD auto off

Setting command	LCD _ Auto _ Off, p1
Parameter	p1= "Off" p1= "Long" (10 minutes) p1= "Short" (1 minute)
Request command	LCD _ Auto _ Off?
Response data	d1
Returned value	Same as for setting command

Backlight Brightness

Backlight brightness

Setting backlight brightness

Setting command	Backlight _ Brightness, p1
Parameter	p1= "0" p1= "1" p1= "2" p1= "3"
Request command	Backlight _ Brightness?
Response data	d1
Returned value	Same as for setting command

Battery Type

Battery type

Setting battery type

Setting command	Battery _ Type, p1
Parameter	p1= "Alkaline" p1= "Nickel"
Request command	Battery _ Type?
Response data	d1
Returned value	Same as for setting command

SD Card Total Size

SD memory card capacity

Request capacity of SD memory card

Request command	SD _ Card _ Total _ Size?
Response data	d1= 0 to 32768 (MB)

There is no setting command

SD Card Free Size

SD memory card free space

Request free space of SD memory card

Request command	SD _ Card _ Free _ Size?
Response data	d1= 0 to 32768 (MB)

There is no setting command

SD Card Percentage

SD memory card free space percentage

Request percentage of free space

Request command	SD _ Card _ Percentage?
Response data	d1= 0 to 100

There is no setting command

Display, performance

Time Level Time Scale

Time scale of time-level display

Setting time scale of time-level display

Setting command	Time _ Level _ Time _ Scale, p1
Parameter	p1= "20s" p1= "1m" p1= "2m"
Request command	Time _ Level _ Time _ Scale?
Response data	d1
Returned value	Same as for setting command

Range X

Xch range upper limit

Setting of X channel range

Setting command	Range _ X, p1
Parameter	p1= "1" p1= "10"
Request command	Range _ X?
Response data	d1
Returned value	Same as for setting command

Range Y

Ych range upper limit

Setting of Y channel range

Setting command	Range _ Y, p1
Parameter	p1= "1" p1= "10"
Request command	Range _ Y?
Response data	d1
Returned value	Same as for setting command

Range Z

Zch range upper limit

Setting of Z channel range

Setting command Range _Z, p1

Parameter p1= "1"
p1= "10"

Request command Range _Z?

Response data d1

Returned value Same as for setting command

Display Channel Setting

Display channel setting

Setting of display channel

Setting command Display _Channel _Setting, p1

Parameter p1= "X" (Xch)
p1= "Y" (Ych)
p1= "Z" (Zch)
P1= "XYZ" (Three axis)

Request command Display _Channel _Setting?

Response data d1

Returned value Same as for setting command

Max Hold Reset

Max hold reset

Reset the max hold value

Setting command Max _Hold _Reset, p1

Parameter p1= "Off"
p1= "On"

The value is reset regardless of a parameter.

This command is invalid except for when the max hold screen is displayed.

I/O

OUTPUT

Output setting

Setting signal output

Setting command	OUTPUT, p1
Parameter	p1= "Off" p1= "On"
Request command	OUTPUT?
Response data	d1
Returned value	Same as for setting command

OUTPUT Quantity

Output quantity

Setting output signal type

Setting command	OUTPUT _ Quantity, p1
Parameter	p1= "Acc" p1= "Acc.nonBand Limiting" p1= "Vel"
Request command	OUTPUT _ Quantity?
Response data	d1
Returned value	Same as for setting command

OUTPUT Band

Output frequency characteristic

Setting output frequency characteristic

Setting command	OUTPUT _Band, p1
Parameter	p1= “not-weighed” (In the case of Vel. : Building Damage) p1= “Interlock” (In the case of Vel. : Human Exposure) p1= “Selected frequency band” (only RT mode)
Request command	OUTPUT _Band?
Response data	d1
Returned value	Same as for setting command

Comparator Node Number

Comparator node number

Setting of Comparator Node Number

Setting command	Comparator _Node _Number, p1
Parameter	p1= “Off” p1= “1” p1= “2” p1= “3” p1= “4” p1= “5” p1= “6”
Request command	Comparator _Node _Number?
Response data	d1
Returned value	Same as for setting command

Comparator Node“x” Frequency

Comparator node frequency

Setting node“x” frequency setting

Set frequency of xth node

The value multiplied by 0.1 is set as the parameter

Setting command	Comparator Node “x” Frequency, p1
Parameter	p1= 5 to 3150
Request command	Comparator Node “x” Frequency?
Response data	d1
Returned value	Same as for setting command

Comparator Node“x” PPV

Comparator node PPV

Comparator node“x” PPV setting

Set PPV threshold of xth node

The value multiplied by 0.01 is set as the parameter

Setting command	Comparator Node “x” PPV, p1
Parameter	p1= 5 to 10000
Request command	Comparator Node “x” PPV?
Response data	d1
Returned value	Same as for setting command

Communication Interface

Communication interface

Setting communication interface

Setting command	Communication _ Interface, p1
Parameter	p1=“Off” p1= “USB” p1= “RS232C”
Request command	Communication _ Interface?
Response data	d1
Returned value	Same as for setting command

Baud Rate

RS-232C baud rate

Setting RS-232C baud rate

Setting command Baud _ Rate, p1

Parameter p1= "38400"
 p1= "57600"
 p1= "115200"

Request command Baud _ Rate?

Response data d1

Returned value Same as for setting command

Communication Flow

RS-232C communication flow

Setting RS-232C Communication Flow

Setting command Communication _ Flow, p1

Parameter p1= "None"
 p1= "Xon"
 p1= "RTS"

Request command Communication _ Flow?

Response data d1

Returned value Same as for setting command

Store

Store Mode

Store mode

Setting store mode

Setting command Store _ Mode, p1

Parameter p1= "Manual"
 p1= "Auto"
 p1= "Timer Auto"

Request command Store _ Mode?

Response data d1

Returned value Same as for setting command

Store Name

Store name

Setting store name

Setting command Store _ Name, p1

Parameter p1= 0 to 9999

Request command Store _ Name?

Response data d1

Returned value Same as for setting command

Inst Store Interval

Inst store interval

Setting Inst store interval

Setting command Inst _ Store _ Interval, p1

Parameter p1= "Off"
 p1= "100ms"

Request command Inst _ Store _ Interval?

Response data d1

Returned value Same as for setting command

Calculation Interval Preset

Calculation interval

Setting calculation interval

Setting command	Calculation _ Interval _ Preset, p1
Parameter	p1= "Off" p1= "10s" p1= "30s" p1= "1m" p1= "5m" p1= "10m" p1= "15m" p1= "30m" p1= "1h" p1= "8h" p1= "24h" p1= "Manual" (User setting)
Request command	Calculation _ Interval _ Preset?
Response data	d1
Returned value	Same as for setting command

Calculation Interval (Num)

Calculation interval of user setting (number)

Setting value when "Calculation _ Interval _ Preset" command parameter is "Manual"

Setting command	Calculation _ Interval _ (Num), p1
Parameter	p1= 1 to 59 (Time unit is s [second] or m [minute]) p1= 1 to 24 (Time unit is h [hour])
Request command	Calculation _ Interval _ (Num)?
Response data	d1
Returned value	Same as for setting command

Calculation Interval (Unit)

Calculation interval of user setting (unit)

Setting time unit when “Calculation Interval Preset” command parameter is “Manual”

Setting command	Calculation _ Interval _ (Unit), p1
Parameter	p1= “s” p1= “m” p1= “h”
Request command	Calculation _ Interval _ (Unit)?
Response data	d1
Returned value	Same as for setting command

Measurement Time Preset Manual

Measurement time of manual store

Setting measurement time of the manual store mode

Setting command	Measurement _ Time _ Preset _ Manual, p1
Parameter	p1= “10s” p1= “30s” p1= “1m” p1= “5m” p1= “10m” p1= “15m” p1= “30m” p1= “1h” p1= “8h” p1= “24h” p1= “Manual” (User setting)
Request command	Measurement _ Time _ Preset _ Manual?
Response data	d1
Returned value	Same as for setting command

Measurement Time Manual (Num)

Measurement time of user setting on manual store (number)

Setting value when “Measurement Time Preset” command parameter is “Manual” on manual store mode

Setting command	Measurement _ Time _ Manual _ (Num), p1
Parameter	p1= 1 to 59 (Time unit is s [second] or m [minute]) p1= 1 to 24 (Time unit is h [hour])
Request command	Measurement _ Time _ Manual _ (Num)?
Response data	d1
Returned value	Same as for setting command

Measurement Time Manual (Unit)

Measurement time of user setting on manual store (unit)

Setting time unit when “Measurement Time Preset” command parameter is “Manual” on manual store mode

Setting command	Measurement _ Time _ Manual _ (Unit), p1
Parameter	p1= “s” p1= “m” p1= “h”
Request command	Measurement _ Time _ Manual _ (Unit)?
Response data	d1
Returned value	Same as for setting command

Measurement Time Preset Auto

Total measurement time of auto store

Setting total measurement time of the auto store mode

Setting command	Measurement _ Time _ Preset _ Auto, p1
Parameter	p1= "10s" p1= "30s" p1= "1m" p1= "5m" p1= "10m" p1= "15m" p1= "30m" p1= "1h" p1= "8h" p1= "24h" p1= "Manual" (User setting)"
Request command	Measurement _ Time _ Preset _ Auto?
Response data	d1
Returned value	Same as for setting command

Measurement Time Auto (Num)

Total measurement time of user setting on auto store (number)

Setting value when "Measurement Time Preset" command parameter is "Manual" on auto store mode

Setting command	Measurement _ Time _ Auto _ (Num), p1
Parameter	p1= 1 to 59 (Time unit is s [second] or m [minute]) p1= 1 to 23 (Time unit is h [hour]) p1= 1 to 200 (For Time Institution Day also up to 41 for Inst Store ON)
Request command	Measurement _ Time _ Auto _ (Num)?
Response data	d1
Returned value	Same as for setting command

Measurement Time Auto (Unit)

Total measurement time of user setting on auto store (unit)

Setting time unit when “Measurement Time Preset” command parameter is “Manual” on auto store mode

Setting command	Measurement _ Time _ Auto _ (Unit), p1
Parameter	p1= “s” p1= “m” p1= “h” p1= “day”
Request command	Measurement _ Time _ Auto _ (Unit)?
Response data	d1
Returned value	Same as for setting command

Timer Auto Start Time

Timer auto start time

Setting timer auto start time

Setting command	Timer _ Auto _ Start _ Time, p1/p2/p3 _ p4:p5:p6
Parameter	p1= 2018 or after (year) p2= 1 to 12 (month) p3= 1 to 31 (date) p4= 0 to 23 (hour) p5= 0 to 59 (minute) p6= 0 (second: only 0)
Request command	Timer _ Auto _ Start _ Time?
Response data	d1/d2/d3 _ d4:d5:d6
Returned value	Same as for setting command

Timer Auto Stop Time

Timer auto stop time

Setting timer auto stop time

Setting command Timer _ Auto _ Stop _ Time, p1/p2/p3 _ p4:p5:p6

Parameter p1= 2018 or after (year)
 p2= 1 to 12 (month)
 p3= 1 to 31 (date)
 p4= 0 to 23 (hour)
 p5= 0 to 59 (minute)
 p6= 0 (second: only 0)

Request command Timer _ Auto _ Stop _ Time?

Response data d1/d2/d3 _ d4:d5:d6

Returned value Same as for setting command

Returned value Same as for setting command

Timer Auto Interval

Timer auto measurement interval

Setting timer auto measurement interval

Setting command Timer _ Auto _ Interval, p1

Parameter p1= "Off"
 p1= "5m"
 p1= "10m"
 p1= "15m"
 p1= "30m"
 p1= "1h"
 p1= "8h"
 p1= "24h"

Request command Timer _ Auto _ Interval?

Response data d1

Returned value Same as for setting command

Sleep Mode

Sleep mode

Setting ON/OFF of sleep mode

Setting command	Sleep \square Mode, p1
Parameter	p1= "Off" p1= "On"
Request command	Sleep \square Mode?
Response data	d1
Returned value	Same as for setting command

Manual Address

Manual store address

Setting manual store address

Setting command	Manual \square Address, p1
Parameter	p1= "1 to 1000"
Request command	Manual \square Address?
Response data	d1
Returned value	Same as for setting command

Measure

Measurement

Measurement start and stop

Setting command	Measure, p1
Parameter	p1= "Start" p1= "Stop"
Request command	Measure?
Response data	d1
Returned value	Same as for setting command

When executing the command on the address in which data exists already, the data is overwritten.

Pause

Pause

Pause a measurement

Setting command	Pause, p1
Parameter	p1= "Pause" p1= "Clear"
Request command	Pause?
Response data	d1
Returned value	Same as for setting command

Manual Store

Manual store

Storing the calculated value in manual store

Setting command	Manual _ Store, p1
Parameter	p1= "Start" (Execute store)
Request command	There is no request command

Measurement Start Time

Measurement (operation) start time

Request measurement (operation) start time

Request command	Measurement _ Start _ Time?
Response data	d1/d2/d3 _ d4:d5:d6
Returned value	d1= 2018 or after (year) d2= 1 to 12 (month) d3= 1 to 31 (date) d4= 0 to 23 (hour) d5= 0 to 59 (minute) d6= 0 to 59 (second)

There is no setting command

Measurement Stop Time

Measurement (operation) stop time

Request measurement (operation) stop time

Request command Measurement _ Stop _ Time?

Response data d1/d2/d3 _ d4:d5:d6

Returned value d1= 2018 or after (year)
 d2= 1 to 12 (month)
 d3= 1 to 31 (date)
 d4= 0 to 23 (hour)
 d5= 0 to 59 (minute)
 d6= 0 to 59 (second)

There is no setting command

Measurement Elapsed Time

Measurement elapsed time

Request measurement elapsed time (second)

Request command Measurement _ Elapsed _ Time?

Response data d1= 0 to 3600000 (second)

There is no request command

Measurement

Acc Weighted X

Frequency weighting of X-axis for acceleration

Setting Frequency weighting of X for Acc.

Setting command Acc _ Weighted _ X, p1

Parameter p1= "Wm"
 p1= "Wb"
 p1= "Wd"
 p1= "Non-Weighting"

Request command Acc _ Weighted _ X?

Response data d1

Returned value Same as for setting command

Acc Weighted Y

Frequency weighting of Y-axis for acceleration

Setting Frequency weighting of Y for Acc.

Setting command Acc _ Weighted _ Y, p1

Parameter p1= "Wm"

 p1= "Wb"

 p1= "Wd"

 p1= "Non-Weighting"

Request command Acc _ Weighted _ Y?

Response data d1

Returned value Same as for setting command

Acc Weighted Z

Frequency weighting of Z-axis for acceleration

Setting Frequency weighting of Z for Acc.

Setting command Acc _ Weighted _ Z, p1

Parameter p1= "Wm"

 p1= "Wb"

 p1= "Wd"

 p1= "Non-Weighting"

Request command Acc _ Weighted _ Z?

Response data d1

Returned value Same as for setting command

Acc Lower

Frequency weighting of Acc lower

Setting lower limit of frequency range for Acc.

Setting command	Acc □ Lower, p1
Parameter	p1= "0.5Hz" p1= "1Hz" p1= "4Hz"
Request command	Acc □ Lower?
Response data	d1
Returned value	Same as for setting command

Acc Upper

Frequency weighting of Acc upper

Setting upper limit of frequency range for Acc.

Setting command	Acc □ Upper, p1
Parameter	p1= "80Hz" p1= "100Hz" p1= "250Hz" p1= "Sensor Dependent"
Request command	Acc □ Upper?
Response data	d1
Returned value	Same as for setting command

Vel Disp Build Lower

Frequency weighting of building Vel and Disp lower

Setting lower limit of frequency range for Building damage Vel. and Disp.

Setting command	Vel □ Disp □ Build □ Lower, p1
Parameter	p1= "0.5Hz" p1= "1Hz" p1= "4Hz"
Request command	Vel □ Disp □ Build □ Lower?
Response data	d1
Returned value	Same as for setting command

Vel Disp Build Upper

Frequency weighting of building Vel and Disp upper

Setting upper limit of frequency range for Building damage Vel. and Disp.

Setting command Vel _ Disp _ Build _ Upper, p1

Parameter p1= "80Hz"

p1= "100Hz"

p1= "250Hz"

p1="Sensor Dependent"

Request command Vel _ Disp _ Build _ Upper?

Response data d1

Returned value Same as for setting command

Vel Human Lower

Frequency weighting of human Vel lower

Setting lower limit of frequency range for Human exposure Vel.

Setting command Vel _ Human _ Lower, p1

Parameter p1= "0.5Hz"

p1= "1Hz"

p1= "4Hz"

Request command Vel _ Human _ Lower?

Response data d1

Returned value Same as for setting command

Vel Human Upper

Frequency weighting of human Vel upper

Setting upper limit of frequency range for Human exposure Vel.

Setting command	Vel _ Human _ Upper, p1
Parameter	p1= "80Hz" p1= "100Hz" p1= "250Hz" p1="Sensor Dependent"
Request command	Vel _ Human _ Upper?
Response data	d1
Returned value	Same as for setting command

Dominant Frequency Line

Determine for dominant frequency line

Setting of Dominant Frequency Line

Setting command	Dominant _ Frequency _ Line, p1
Parameter	p1= "No Line" p1= "Line1" p1= "Line2" p1="Line3"
Request command	Dominant _ Frequency _ Line?
Response data	d1
Returned value	Same as for setting command

SBR Acc Lower

Frequency weighting of Acc lower (SBR Mode)

HPF on unweighted Acc. on SBR mode

Setting command	SBR □ Acc □ Lower, p1
Parameter	p1= "0.5Hz" p1= "1Hz" p1= "4Hz"
Request command	SBR □ Acc □ Lower?
Response data	d1
Returned value	Same as for setting command

SBR Acc Upper

Frequency weighting of Acc upper (SBR Mode)

LPF on unweighted Acc. on SBR mode

Setting command	SBR □ Acc □ Upper, p1
Parameter	p1= "80Hz" p1= "100Hz" p1= "250Hz" p1="Sensor Dependent"
Request command	SBR □ Acc □ Upper?
Response data	d1
Returned value	Same as for setting command

SBR Dominant Frequency Line

Determine for dominant frequency line (SBR Mode)

Setting of Dominant Frequency Line (SBR Mode)

Setting command SBR _ Dominant _ Frequency _ Line, p1

Parameter p1= "No Line"

p1= "Line1"

p1= "Line2"

p1="Line3"

Request command SBR _ Dominant _ Frequency _ Line?

Response data d1

Returned value Same as for setting command

Delay Time

Delay time

Setting delayed measurement time

Setting command Delay _ Time, p1

Parameter p1= "Off"

p1= "10s"

Request command Delay _ Time?

Response data d1

Returned value Same as for setting command

Operation

Underrange Inst X

Xch underrange Inst

Request presence of underrange Inst information of X channel

Request command Underrange _ Inst _ X?

Response data d1

Returned value d1= "Off" (there is no information)

d1= "On" (there is information)

There is no setting command

Underrange Calc X

Xch underrange Calc

Request presence of underrange information in processed data of X channel

Request command Underrange _ Calc _ X?

Response data d1

Returned value d1= "Off" (there is no information)

d1= "On" (there is information)

There is no setting command

Overload Inst X

Xch overload Inst

Request presence of overload Inst information of X channel

Request command Overload _ Inst _ X?

Response data d1

Returned value d1= "Off" (there is no information)

d1= "On" (there is information)

There is no setting command

Overload Calc X

Xch overload Calc

Request presence of overload information in processed data of X channel

Request command	Overload _ Calc _ X?
Response data	d1
Returned value	d1= "Off" (there is no information)
	d1= "On" (there is information)

There is no setting command

Underrange Inst Y

Ych underrange Inst

Request presence of underrange Inst information of Y channel

Request command	Underrange _ Inst _ Y?
Response data	d1
Returned value	d1= "Off" (there is no information)
	d1= "On" (there is information)

There is no setting command

Underrange Calc Y

Ych underrange Calc

Request presence of underrange information in processed data of Y channel

Request command	Underrange _ Calc _ Y?
Response data	d1
Returned value	d1= "Off" (there is no information)
	d1= "On" (there is information)

There is no setting command

Overload Inst Y

Ych overload Inst

Request presence of overload Inst information of Y channel

Request command	Overload _ Inst _ Y?	
Response data	d1	
Returned value	d1= "Off"	(there is no information)
	d1= "On"	(there is information)

There is no setting command

Overload Calc Y

Ych overload Calc

Request presence of overload information in processed data of Y channel

Request command	Overload _ Calc _ Y?	
Response data	d1	
Returned value	d1= "Off"	(there is no information)
	d1= "On"	(there is information)

There is no setting command

Underrange Inst Z

Zch underrange Inst

Request presence of underrange Inst information of Z channel

Request command	Underrange _ Inst _ Z?	
Response data	d1	
Returned value	d1= "Off"	(there is no information)
	d1= "On"	(there is information)

There is no setting command

Underrange Calc Z

Zch underrange Calc

Request presence of underrange information in processed data of Z channel

Request command Underrange _ Calc _ Z?

Response data d1

Returned value d1= "Off" (there is no information)

d1= "On" (there is information)

There is no setting command

Overload Inst Z

Zch overload Inst

Request presence of overload Inst information of Z channel

Request command Overload _ Inst _ Z?

Response data d1

Returned value d1= "Off" (there is no information)

d1= "On" (there is information)

There is no setting command

Overload Calc Z

Zch overload Calc

Request presence of overload information in processed data of Z channel

Request command Overload _ Calc _ Z?

Response data d1

Returned value d1= "Off" (there is no information)

d1= "On" (there is information)

There is no setting command

Data output

DOD

Output displayed value

Send the request command at one second interval or longer.

Request command	DOD?	
Response data	d1,d2,...,d67	
Returned value	d1 = "xxx.x"	Acc. of X channel (Inst value)
	d2 = "xxx.x"	PPV of X channel (Inst value)
	d3 = "xxx.x"	D.F. of X channel (Inst value)
	d4 = "xx.xx"	Disp. of X channel (Inst value)
	d5= 0 or 1	Inst Overload information (1: Yes, 0: No)
	d6= 0 or 1	Inst Under-range information (1: Yes, 0: No)
	d7 = "xxx.x"	Acc. of X channel (Max hold value)
	d8 = "xxx.x"	PPV of X channel (Max hold value)
	d9 = "xxx.x"	D.F. of X channel (Max hold value)
	d10 = "xxx.x"	Disp. of X channel (Max hold value)
	d11 = 0 or 1	Max hold Overload information (1: Yes, 0: No)
	d12 = 0 or 1	Max hold Under-range information (1: Yes, 0: No)
	d13 = "xxx.x"	PPV of X channel (Calc value)
	d14 = "xxx.x"	D.F. of X channel (Calc value)
	d15 = "xxx.x"	Disp. of X channel (Calc value)
	d16 = "xxx.x"	Acc. of X channel (Calc value)
	d17 = "xxx.x"	C.F. of X channel (Calc value)
	d18 = "xxx.x"	MTVV of X channel (Calc value)
	d19 = "xxx.x"	VDV of X channel (Calc value)

d20 = "xxx.x"	KBFT or veff,max,30 of X channel (Calc value) (General Mode:KBFT value, SBR Mode: veff,max,30 value)
d21 = 0 or 1	Calc Overload information (1: Yes, 0: No)
d22 = 0 or 1	Calc Under-range information (1: Yes, 0: No)
d23 to d44 :	Y channel information (Same format as X channel)
d45 to d66 :	Z channel information (Same format as X channel)
d67 = "xxx.x"	PVS (Tri axial combine value for PPV)

* "xxx.x" is fixed at 4 digit length. Higher digits are padded with spaces as required.

* In Auto store mode, KBFT (veff,max,30) is output. In Manual store mode, KBFmax (veff,max) is output.

There is no setting command

DOD Calc

Output calculation value

Send the request command at one second interval or longer.

Request command	DOD Calc?	
Response data	d1,d2,...,d67	
Returned value	d1 = "xxx.x"	Acc. of X channel (Inst value)
	d2 = "xxx.x"	PPV of X channel (Inst value)
	d3 = "xxx.x"	D.F. of X channel (Inst value)
	d4 = "xxx.x"	Disp. of X channel (Inst value)
	d5= 0 or 1	Inst Overload information (1: Yes, 0: No)
	d6= 0 or 1	Inst Under-range information (1: Yes, 0: No)
	d7 = "xxx.x"	Acc. of X channel (Max hold value)
	d8 = "xxx.x"	PPV of X channel (Max hold value)

d9 = "xxx.x"	D.F. of X channel (Max hold value)
d10 = "xxx.x"	Disp. of X channel (Max hold value)
d11 = 0 or 1	Max hold Overload information (1: Yes, 0: No)
d12 = 0 or 1	Max hold Under-range information (1: Yes, 0: No)
d13 = "xxx.x"	PPV of X channel (Calc value)
d14 = "xxx.x"	D.F. of X channel (Calc value)
d15 = "xxx.x"	Disp. of X channel (Calc value)
d16 = "xxx.x"	Acc. of X channel (Calc value)
d17 = "xxx.x"	C.F. of X channel (Calc value)
d18 = "xxx.x"	MTVV of X channel (Calc value)
d19 = "xxx.x"	VDV of X channel (Calc value)
d20 = "xxx.x"	KBFT or veff,max,30 of X channel (Calc value) (General Mode:KBFT value, SBR Mode: veff,max,30 value)
d21 = 0 or 1	Calc Overload information (1: Yes, 0: No)
d22 = 0 or 1	Calc Under-range information (1: Yes, 0: No)
d23 to d44 :	Y channel information (Same format as X channel)
d45 to d66 :	Z channel information (Same format as X channel)
d67 = "xxx.x"	PVS (Tri axial combine value for PPV)

* "xxx.x" is fixed at 4 digit length. Higher digits are padded with spaces as required.

* In Auto store mode, KBFT (veff,max,30) is output. In Manual store mode, KBFmax (veff,max) is output.

There is no setting command

DRD

Continuous output

Data are sent periodically to the computer every 100 msec.

To stop the data transfer, send the stop request transfer code <SUB> (hexadecimal notation: 1AH).

Request command	DRD?	
Response data	d1,d2,...,d67	
Returned value	d1 = "xxx.x"	Acc. of X channel (Inst value)
	d2 = "xxx.x"	PPV of X channel (Inst value)
	d3 = "xxx.x"	D.F. of X channel (Inst value)
	d4 = "xxx.x"	Disp. of X channel (Inst value)
	d5= 0 or 1	Inst Overload information (1: Yes, 0: No)
	d6= 0 or 1	Inst Under-range information (1: Yes, 0: No)
	d7 = "xxx.x"	Acc. of X channel (Max hold value)
	d8 = "xxx.x"	PPV of X channel (Max hold value)
	d8 = "xxx.x"	D.F. of X channel (Max hold value)
	d10 = "xxx.x"	Disp. of X channel (Max hold value)
	d11 = 0 or 1	Max hold Overload information (1: Yes, 0: No)
	d12 = 0 or 1	Max hold Under-range information (1: Yes, 0: No)
	d13 = "xxx.x"	PPV of X channel (Calc value)
	d14 = "xxx.x"	D.F. of X channel (Calc value)
	d15 = "xxx.x"	Disp. of X channel (Calc value)
	d16 = "xxx.x"	Acc. of X channel (Calc value)
	d17 = "xxx.x"	C.F. of X channel (Calc value)
	d18 = "xxx.x"	MTVV of X channel (Calc value)

d19 = "xxx.x"	VDV of X channel (Calc value)
d20 = "xxx.x"	KBFT or veff,max,30 of X channel (Calc value) (General Mode:KBFT value, SBR Mode: veff,max,30 value)
d21 = 0 or 1	Calc Overload information (1: Yes, 0: No)
d22 = 0 or 1	Calc Under-range information (1: Yes, 0: No)
d23 to d44 :	Y channel information (Same format as X channel)
d45 to d66 :	Z channel information (Same format as X channel)
d67 = "xxx.x"	PVS (Tri axial combine value for PPV)

- * "xxx.x" is fixed at 4 digit length. Higher digits are padded with spaces as required.
- * In Auto store mode, KBFT (veff,max,30) is output. In Manual store mode, KBFmax (veff,max) is output.

There is no setting command

Command example

The example of a setting by a command is shown.

Using a request command after a setting is recommended.

Basic setting

Setting the time scale of time-level display to “20s”

Time _ Level _ Time _ Scale, 20s

Setting the level range upper limit of X channel, Y channel and Z channel to “10 m/s²”

Range _ X, 1

Range _ Y, 1

Range _ Z, 1

When operating auto store

Setting the Store Mode to “Auto”

Store _ Mode, Auto

Setting the Store Name to “0100”

Store _ Name, 100

Setting the Total Measurement Time to “10min”

Measurement _ Time _ Preset _ Auto, 10m

Setting the Inst Store Interval to “100ms”

Inst _ Store _ Interval, 100ms

Setting the Calculation Interval to “1min”

Calculation _ Interval _ Preset, 1m

Measurement start / stop (store)

Measure, Start * No confirmation about overwriting.

Measure, Stop

Measurement data acquisition

DOD?

When operating manual store

Setting the Store Mode to “Manual”

Store Mode, Manual

Setting the Store Name to “0200”

Store Name, 200

Setting the Measurement Time to “15min”

Measurement Time Preset Auto, 15m

Measurement start / stop

Measure, Start

Measure, Stop

Saving of the store result

Manual Store, Start

Measurement data acquisition

DOD?

Reference Information

Battery life

Important

Battery life varies depending on the setting of this unit.

Examples of the battery life when measuring continuously

Battery type Operating temperature	Alkaline batteries	Nickel metal-hydride batteries
-20°C	Approx. 7 hours	Approx. 24 hours (to -10°C)
+23°C	Approx. 24 hours	Approx. 24 hours
+50°C	Approx. 24 hours	Approx. 24 hours

Operating condition:

- The PV-83D is connected to the VM-56
- Eco setting is ON
- Inst. store interval is OFF
- Calculation interval is 30 sec

Keeping the backlight on the display screen turned on will shorten battery life by approximately 10% to 40%. (Depending on the brightness of the backlight.)

When AC (AC) output is ON, the battery life is reduced by approximately 30%.

When the communication function is turned ON, battery life is shortened by about 20%.

At option program operation, battery life varies depending on function. When the waveform recording function is turned on with the VX-56WR installed, the battery life is shortened by about 10%.

INPUT connector

The input connector is wired as shown below.

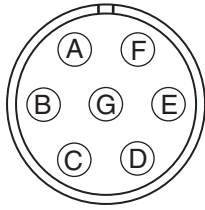

Top view

- A: Unused
- B: Ground
- C: Z channel signal input
- D: Unused
- E: X channel signal input
- F: Y channel signal input
- G: Pickup power supply

Important

Do not connect anything else besides the supplied Vibration Pickup PV-83D. Otherwise damage may occur.

Calibration example using an exciter

The following arrangement can be used to calibrate the vibration pickup with an exciter.

- Sine wave signal oscillator
- Power amplifier DC-300A series II (Manufacturer:Crown)
- Exciter VG-100 (Vertical-directionexciter) (Manufacturer:ARBrown)
- APS-129 (Horizontal-direction exciter) (Manufacturer:ARBrown)
- Reference accelerometer PV-03 (Manufacturer:RION)
- Vibration meter VM-83 (Manufacturer:RION)

Wm, Wb, Wd Frequency response characteristics (typical characteristics)

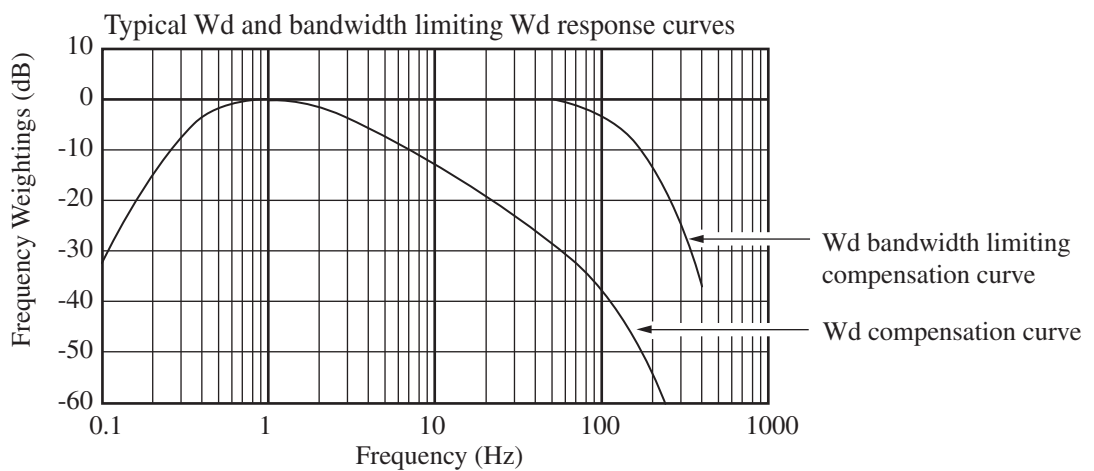
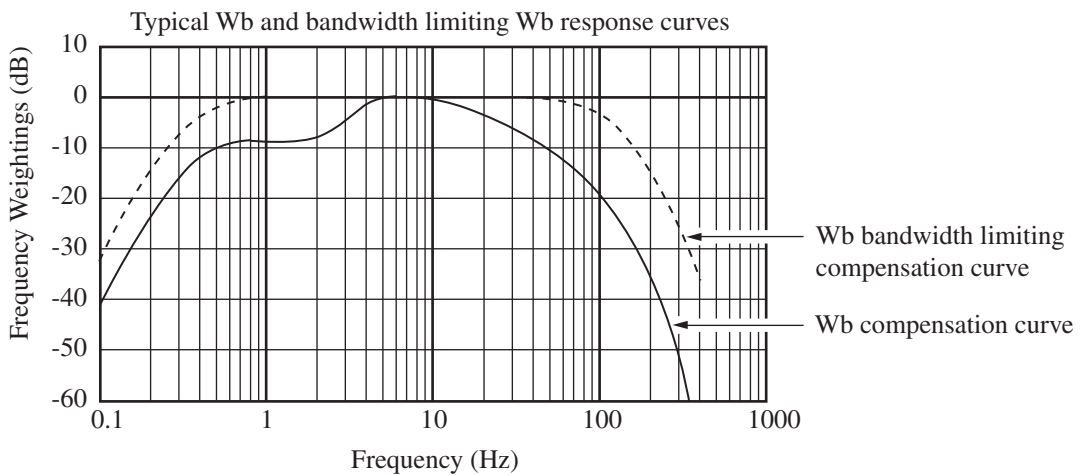
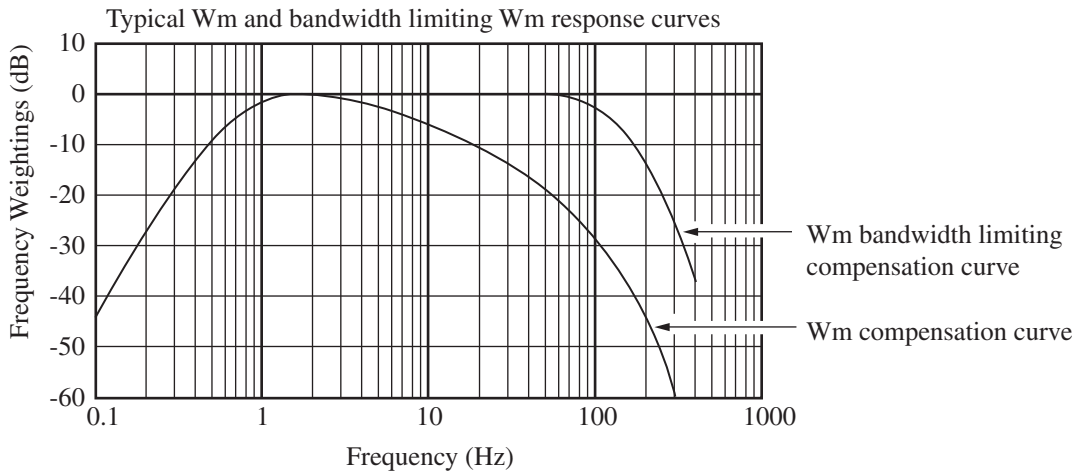

Non-weighting frequency response characteristics (typical characteristics)

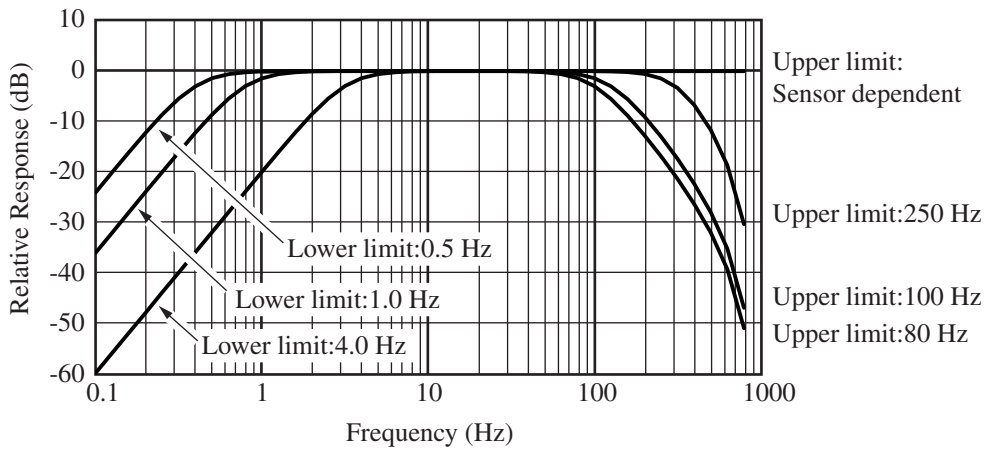

PV-83D frequency response characteristics

The PV-83D is a vibration pickup that converts acceleration into an electrical signal.

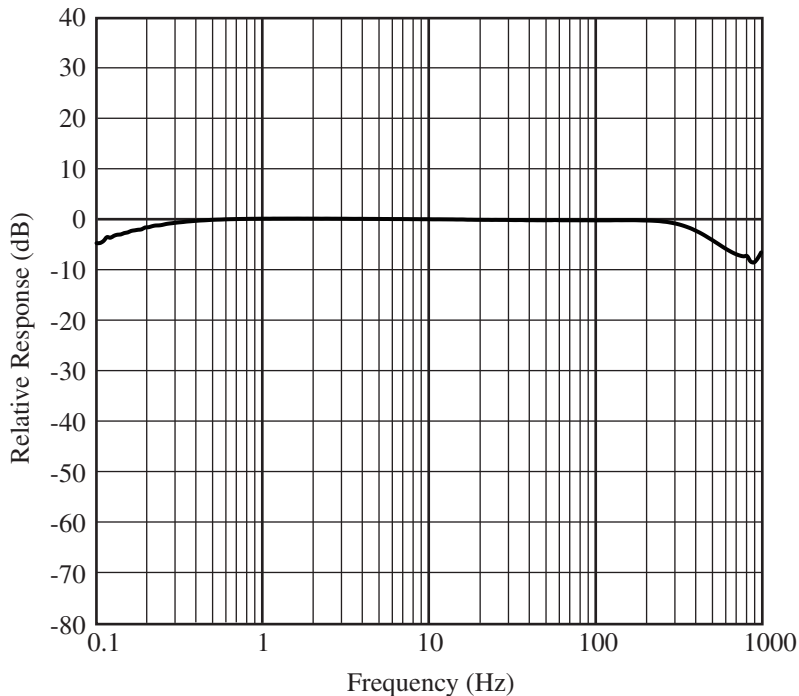

VM-56+PV-83D Frequency response characteristics

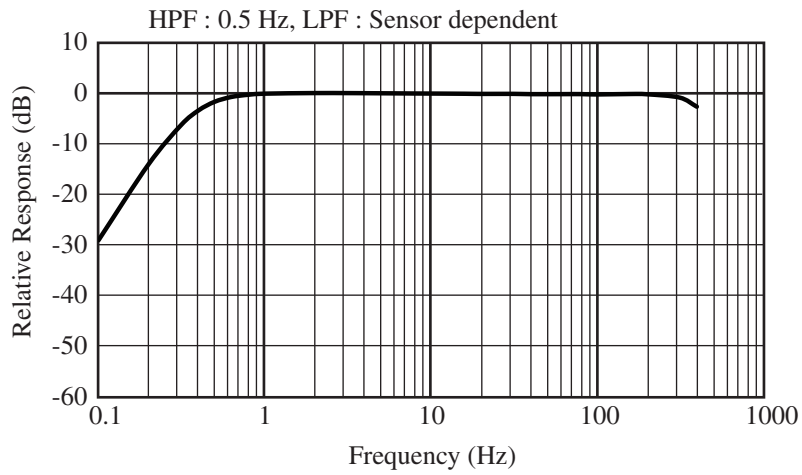

Velocity frequency response characteristics

General : building damage

(Acceleration waveform processed by integral filter and band limit filter.)

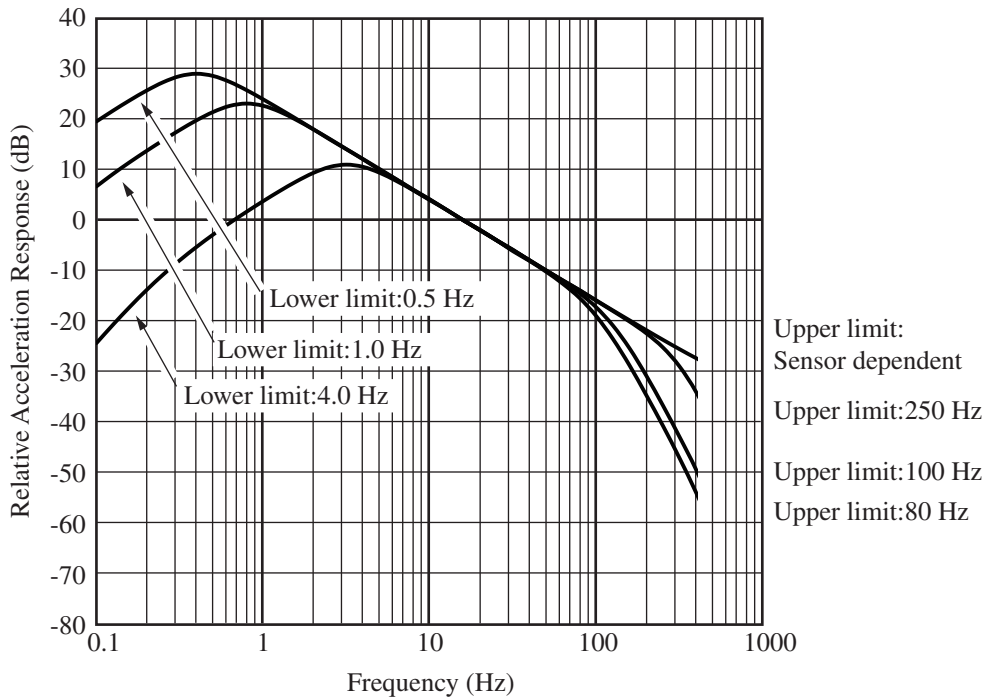

The filter characteristics with flat velocity are as shown below.

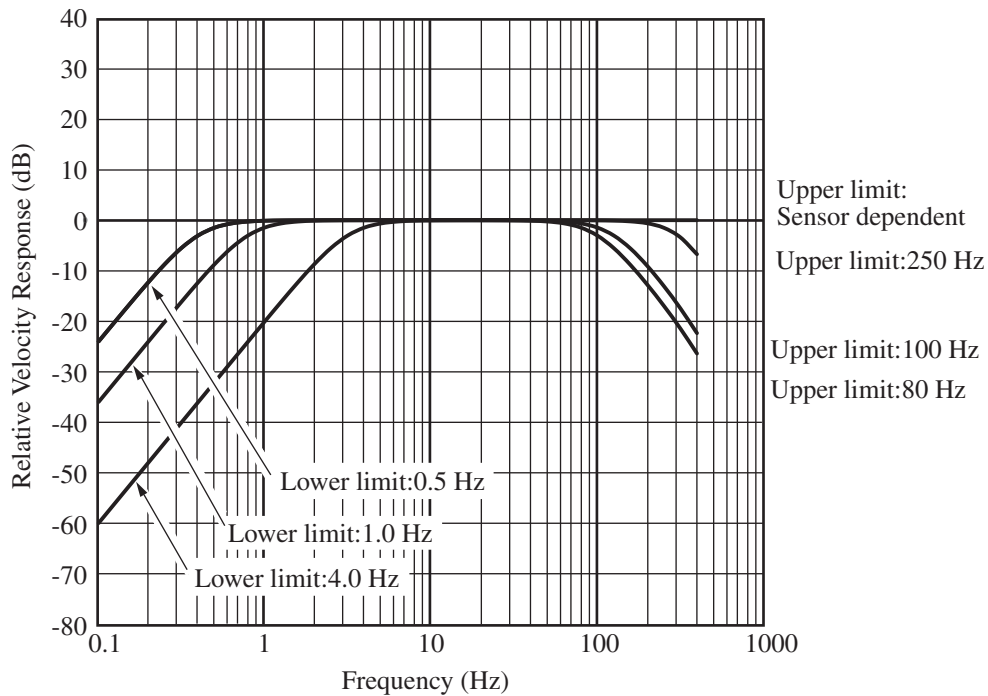

General : KBFT

(Acceleration waveform processed by integral filter, band limit filter, and KB filter.)

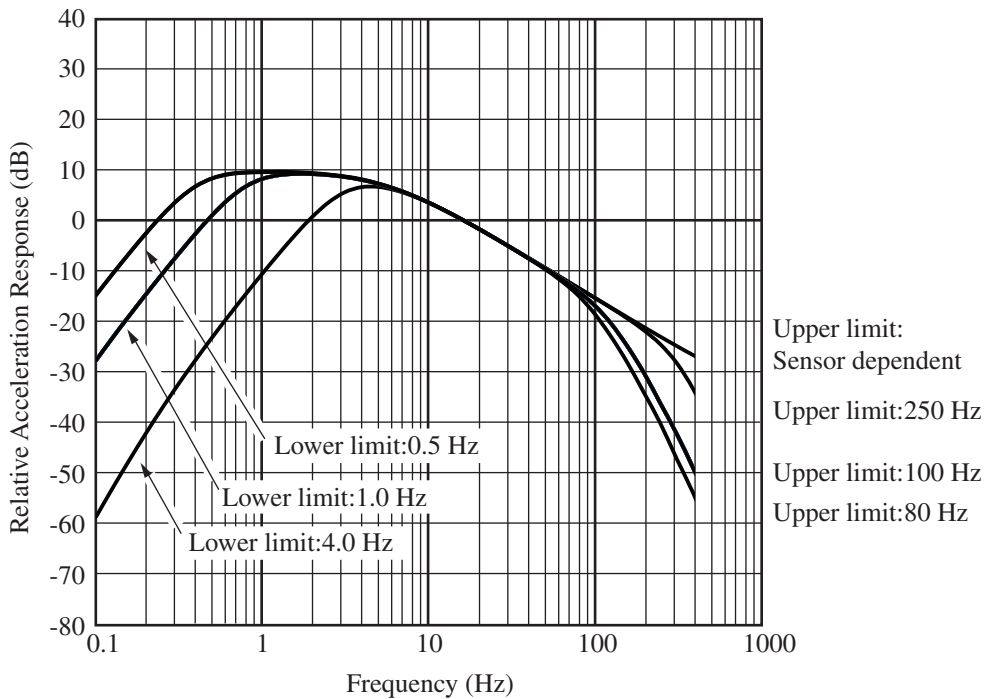

The filter characteristics with flat velocity are as shown below.

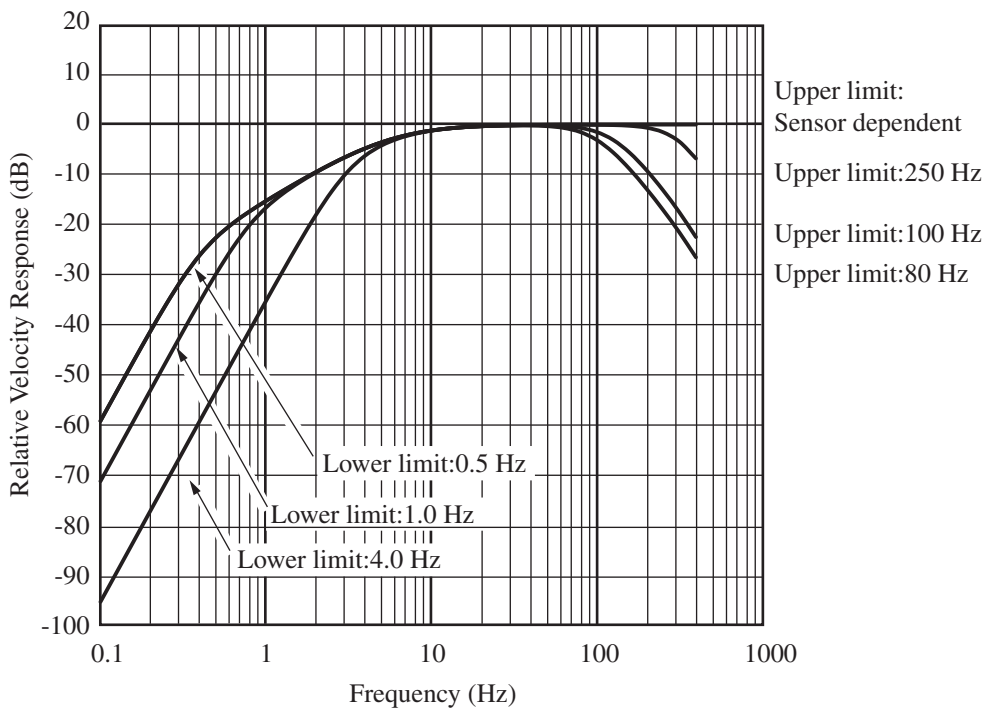

SBR : building damage

(Acceleration waveform processed by integral filter, band limit filter, and KB filter.)

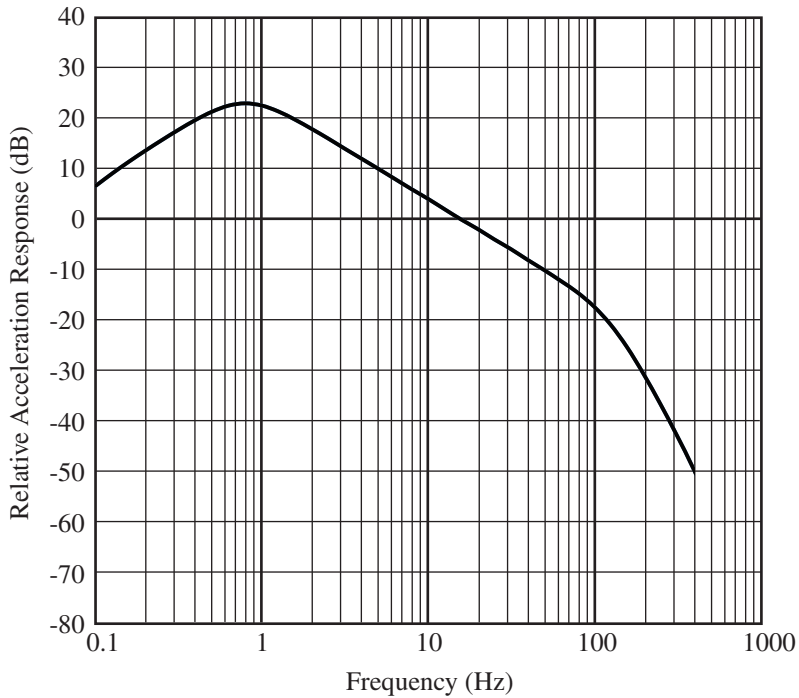

The filter characteristics with flat velocity are as shown below.

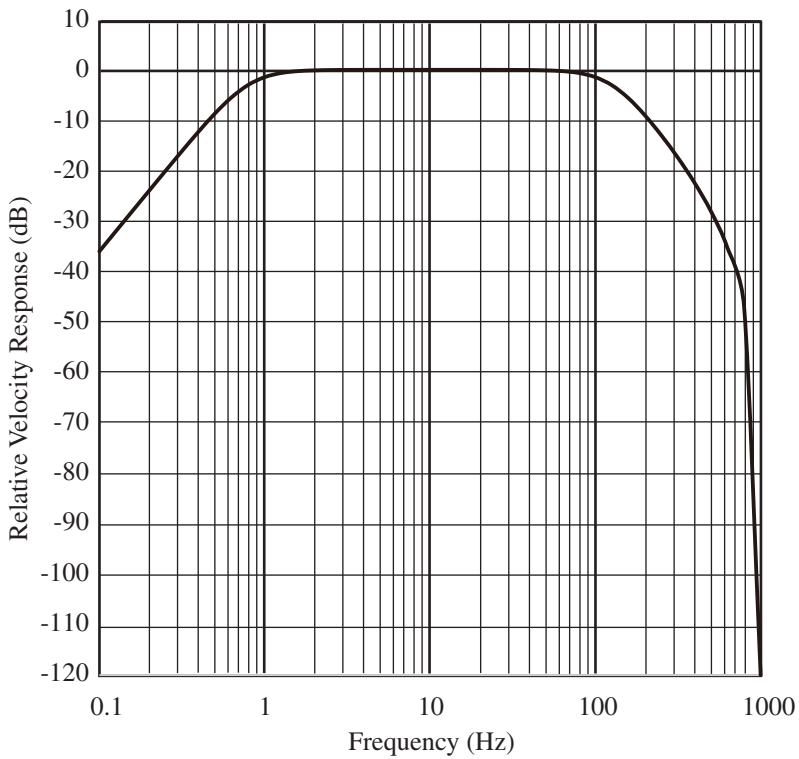

SBR : veff

(Acceleration waveform processed by integral filter, band limit filter (-24 dB/oct), and Hv filter.)

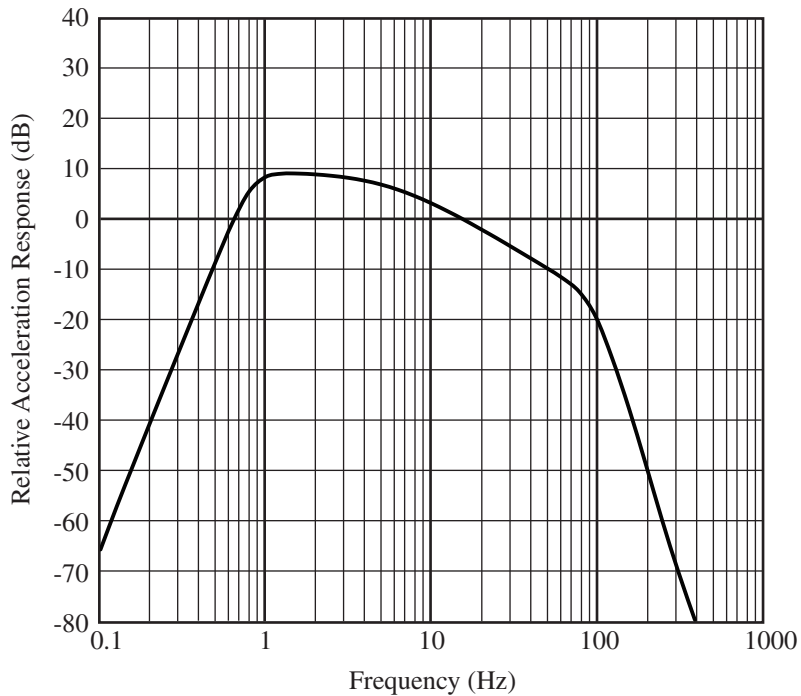

The filter characteristics with flat velocity are as shown below.

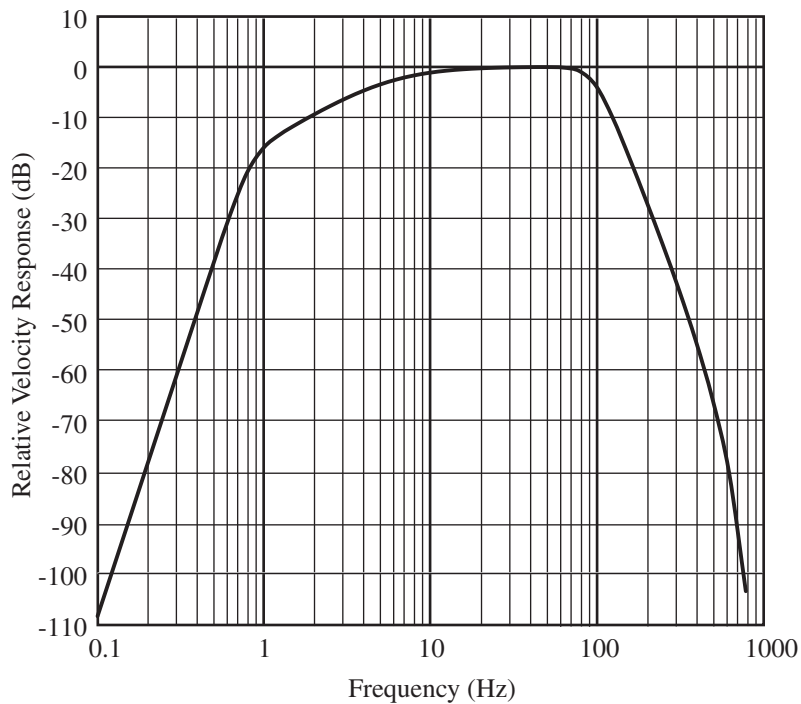

Displacement frequency response characteristics

Acceleration waveform processed by second-order integral filter.

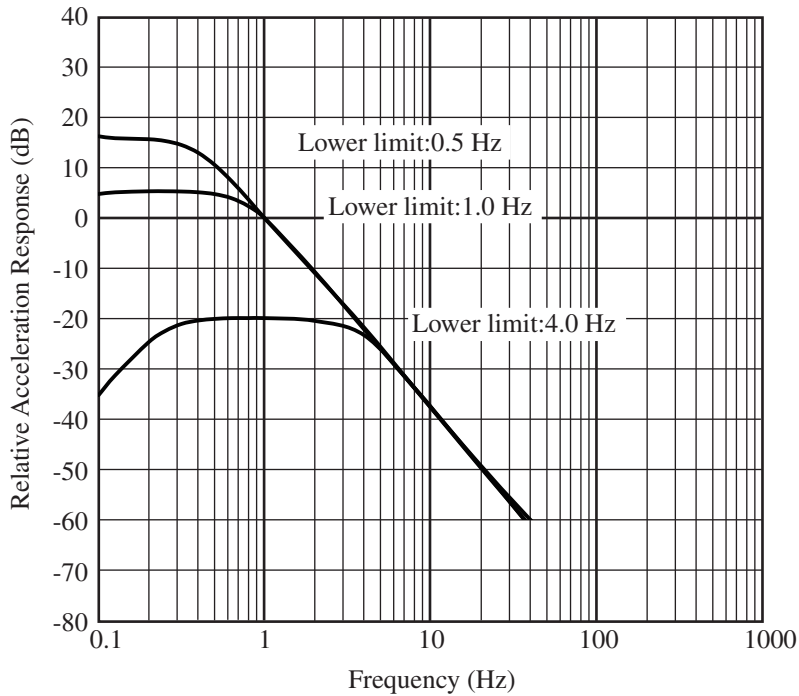

The filter characteristics with flat velocity are as shown below.

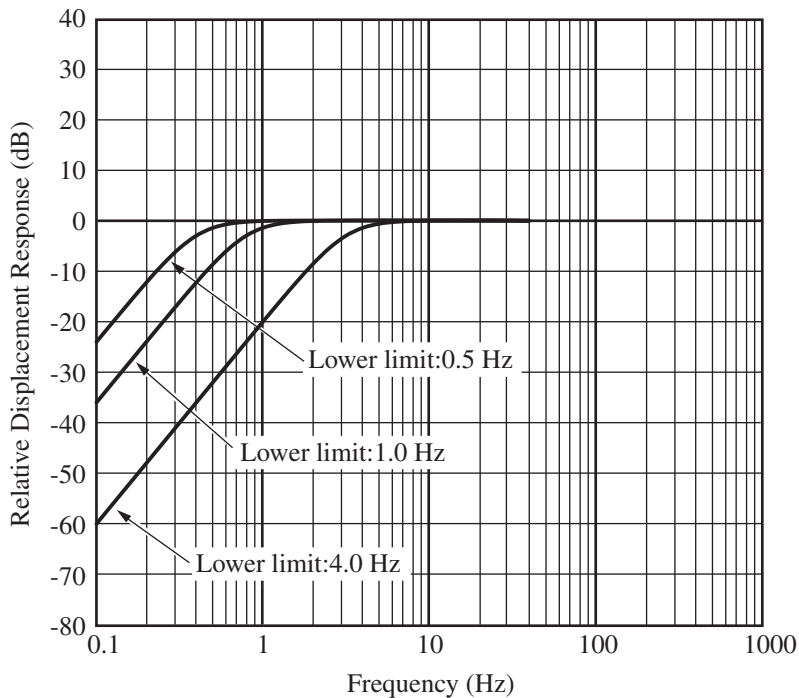

DIN plate frequency response characteristics

*The solid line shows the frequency range of the DIN standard (100 Hz or less)

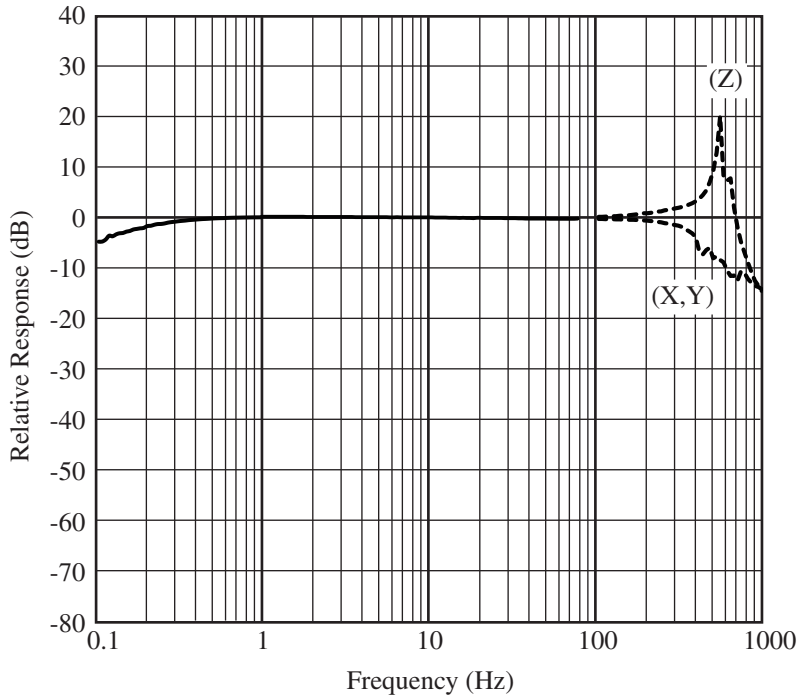

L-bracket frequency response characteristics

When the Y axis is mounted perpendicular to the mounting surface.

*The solid line shows the frequency range of the DIN standard (40 Hz or less)

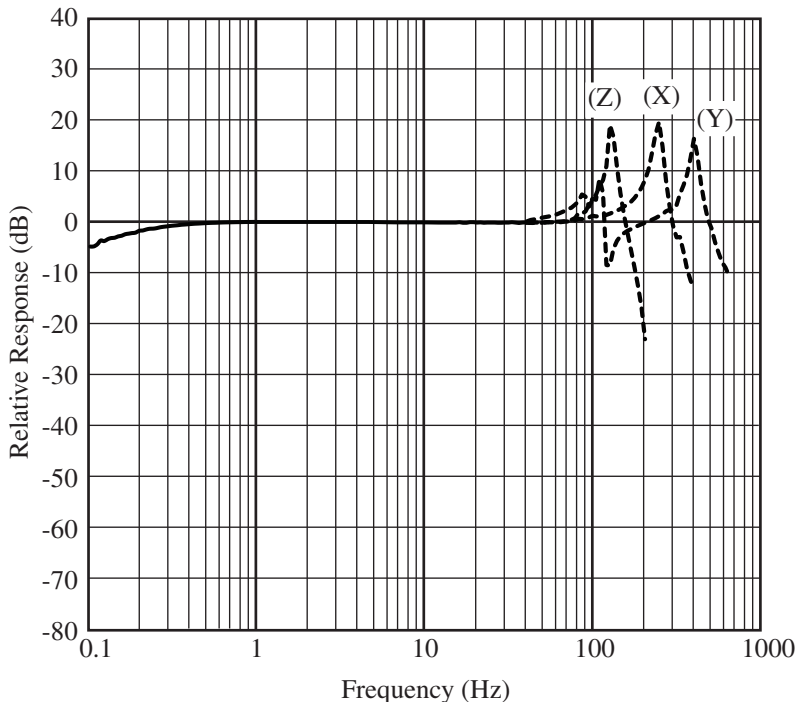

Peak Vector Sum (PVS)

The VM-56 calculates the PVS by tri-axial synthesis (sum of squares) of the PPV for each axis measured every 100 ms.

The PVS determined by computation is stored as the maximum value of PVS every 100 ms.

The calculation formula and a schematic diagram of the PPV waveforms (in the order X axis, Y axis, and Z axis) are shown below.

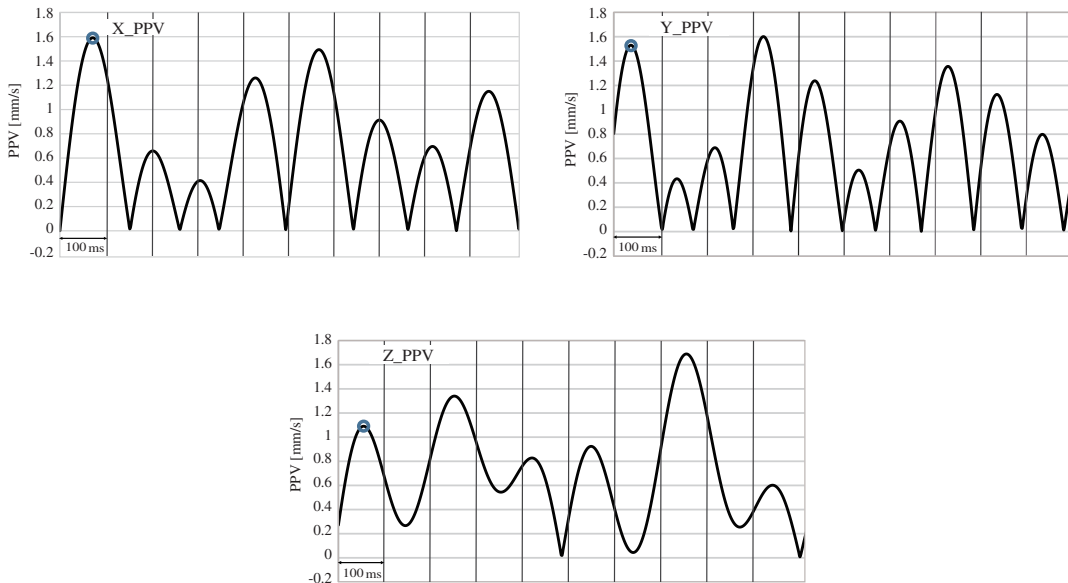

$$PVS = \sqrt{X_PPV^2 + Y_PPV^2 + Z_PPV^2}$$

X_PPV : Peak particle velocity of X axis

Y_PPV : Peak particle velocity of Y axis

Z_PPV : Peak particle velocity of Z axis

Specifications

Applicable standards

DIN 45669-1:2020 (Frequency and measurement range are compatible)

ISO 8041:2005/-1:2017

SBR Meten en beoordelen van trillingen

Deel A: Schade aan gebouwen 2010

Deel B: Hinder voor personen 2013

CE marking

UKCA marking

WEEE Directive

Measurement functions

Tri-axial simultaneous measurement possible

Measured Value

(1)Based on the DIN standard

Maximum absolute value of velocity waveform

PPV

Dominant frequency

D.F.

Maximum weighted vibration severity

KB_{Fmax}

Maximum value of KBF signal
the 30-second section

Maximum value in
 KB_{FT}

(2)Based on the ISO standard

Time-averaged weighted acceleration value

Acc.

Maximum transient vibration value

MTVV

Vibration dose value

VDV

Crest factor

C.F.

(3)Based on the SBR standard

Maximum value of weighting vibration

$V_{eff,max}$

Maximum value of v_{eff} value in the 30-second section

$V_{eff,max,30}$

(4)Others

Displacement (0 to peak)

Disp.

PPV Tri-axial synthesis

PVS

(5) Wave recording (optional)

Time waveform of acceleration signal $a(t)$

(6) 1/3 octave band analysis value (option)

Time average value

Maximum value of acceleration

Three-axis synthesis of band max OA L_{aw}

Operating frequency range

Frequency range 0.5 Hz to 315 Hz

Acceleration and velocity, displacement signal select
band limitation such that the frequency range is as
follows

lower: 0.5 Hz, 1 Hz, 4 Hz

upper: 80 Hz, 100 Hz, 250 Hz,
or Sensor dependent

However, when frequency weighting W_b , W_d specified
by ISO is selected, the frequency range of acceleration
signal processing automatically ranges from 0.5 Hz to
80 Hz. 1 Hz to 80 Hz for W_m

Measuring range

For setting the measurement frequency range, specify
the following measurement range from 1 Hz to 80 Hz.

Based on the DIN standard

Vibration velocity

0.03 mm/s to 100 mm/s

Weighted vibration amount

0.02 mm/s to 100 mm/s

(Reference 16 Hz)

Maximum absolute waveform value

0.05 mm/s to 100 mm/s

(Reference 16 Hz)

Vibration acceleration

0.0003 m/s² to 10 m/s²

Displacement (0 to peak)

0.01 mm to 10 mm

(at 0.5 Hz to 4 Hz)

	Based on the SBR-Deel B standard	
	Vibration velocity	
	0.02 mm/s to 100 mm/s	
	(Frequency band 1 Hz to 80 Hz)	
Instrument noise	Vibration acceleration	
	0.0001 m/s ² or less	
	(Frequency band 1 Hz to 80 Hz)	
	Vibration velocity	
	Max 0.01 mm/s	
	(Frequency band 1 Hz to 80 Hz)	
Frequency weighting	None	(with band limiting filter, according to ISO and DIN)
	KB	(DIN 45669-1)
	Wb, Wd, Wm	(ISO 8041)
	H _V	(SBR-B)
Measurement range	2 range switching, 3 direction independent	
	0.001 m/s ² to 10 m/s ²	
	0.0001 m/s ² to 1 m/s ²	
Sampling frequency	2 kHz	
Measurement delay	VM-56 calculation delay: 2 seconds	
Display	Backlight semitransparent color TFT LCD, WQVGA (400×240 dots)	
	Update interval	
	Bar graph	100 ms
	Numeric display	1 s
	Language	English

Warning display

Warm up period display (Displayed for 1 minute 30 seconds after startup)

Overload Range Lit with full scale input +10.3 dB

Under-range Range Lit with full scale input -71 dB

USB

Mass storage class

Connected to a computer as a storage device, and recognized SD memory card as a removable disk

Communication device class (virtual COM)

Allows control with communication commands using communication device class

RS-232C communication

Allows RS-232C communication using the dedicated cable (I/O connector is used)

Baud rate: 38400 bps / 57600 bps / 115200 bps

Comparator output

Open collector output (I / O terminal used)

Maximum applied voltage +24 V

Internal resistance Approx. 500 Ω

Allowable power dissipation 0.3 W

Threshold level can be set for each frequency

Measurement target PPV

Power requirements

Eight AA batteries or external power supply

When both are present, the external power supply is given priority

Battery operating time

Continuous operation time 24 hours or more

Auto off when the store is off, ACOUT: OFF

* calculation period: 10 min

AC adapter NC-98 series

External power supply voltage

+5 V to +7 V (rated voltage +6 V)

Water and dust resistant performance

IP54

Environmental conditions for operation	-20°C to +50°C, to 90% RH (no condensation)
Environmental conditions for storage	-20°C to +50°C, to 90% RH (no condensation)
Dimensions	Approx. 175 mm (H) × 175 mm (W) × 40 mm (D) (without protruding parts)
Weight	Approx. 780 g (including batteries, excluding vibration pickup)
Vibration pickup	Vibration Pickup PV-83D
Reference sensitivity	60 mV/(m/s ²)
Ambient conditions	-20°C to +60°C (no condensation)
Waterproofing specifications	IPX7 (1.5 m cable included)
Dimensions	Approx. 67 mm dia. × 50.5 mm (H) (excluding connection cord)
Weight	Approx. 450 g (including connection cord)
SD memory card	SD/SDHC (maximum capacity 32 GB) * Use Rion genuine

Supplied accessories

AA alkaline battery	8
Safety instruction	1
Carrying case	1
Certificate of calibration	1
Inspection certificate	1
SD card 512 MB (MC-51SD1)	1
Vibration pickup PV-83D	1

* Download instruction manual from the website

Optional accessories

SD Card 512 MB	MC-51SD1
SD Card 2 GB	MC-20SD2
SD Card 32 GB	MC-32SP3
AC adapter (100 V to 240 V)	NC-98 series
Extension cord	EC-04 series
BNC - Pin output cord	CC-24
Comparator output cable	CC-42C
RS-232C serial I/O cable	CC-42R
USB cable	
DIN plate	VP-54D
L-bracket (for wall mounting)	VP-54L

Program option

Waveform Recording Program	VX-56WR
1/3 Octave Real-time Analysis Program	VX-56RT

Lifetime 10 years

* Conditions for conducting RSC or equivalent maintenance check once a year

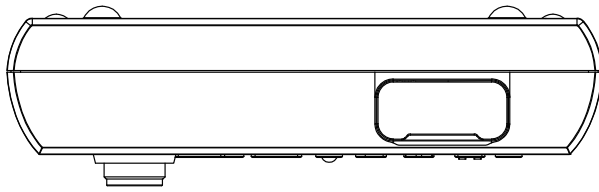

Top panel

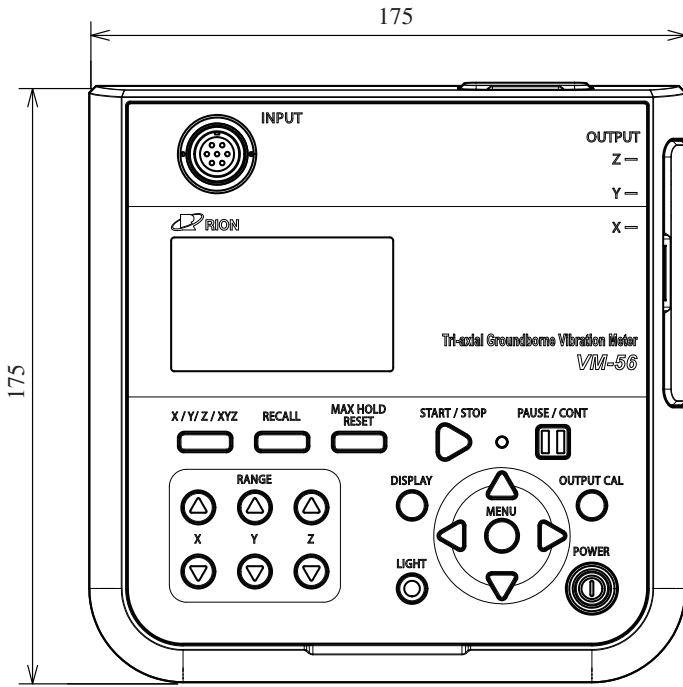

Front panel

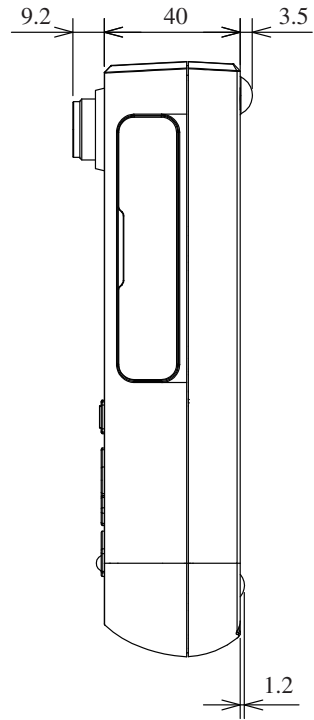

Right side panel

Unit: mm

Dimensional Drawing of VM-56

Specifications of Vibration Pickup PV-83D

Product name	Vibration Pickup
Model	PV-83D
Component	3 axis (Z: vertical, X: horizontal, Y: horizontal)
Maximum measurement acceleration	41.6 m/s ² peak or more (at power supply voltage + 7 V supplied by VM-56 connection)
Reference sensitivity	60 mV / (m/s ²)
Output impedance	100 Ω
Power supply	DC +7 V
Direction and polarity of the sensitive axis of each component	The component sensitive axis is perpendicular to the reference plane, the Y component sensitive axis is the axial direction of the connector, the X component receiving Y, the Z component perpendicular to the sensitive axis. The direction of the sensitive axis is indicated by the arrow on the top of the case, the positive voltage is output with the acceleration in the direction of the arrow
Lateral sensitivity ratio	5% or less (sensitivity difference with respect to sensitive axis sensitivity is -20 dB or less at 0.5 to 315 Hz)
Inherent noise	vibration acceleration 0.0001 m/s ² or less (measurement frequency range 1 Hz to 80 Hz)
Ambient conditions	-20°C to +60°C (sensitivity change is ± 0.3 dB or less with reference to 20°C)
Waterproofing specifications	IPX7

Impact resistance

9800 m/s² peak shock acceleration about 0.2 msec sensitivity change at 5 times ±0.3 dB or less

Dimensions

Approx. 67 mm dia. × 50.5 mm (H) (excluding connecting cord)

Weight

Approx. 450 g (including connection code)

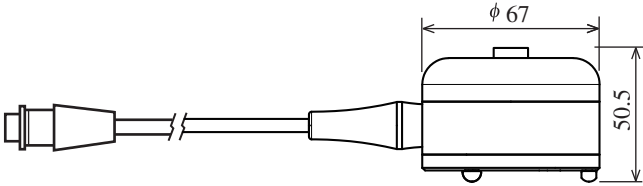

Unit: mm

Dimensional Drawing of Vibration Pickup PV-83D

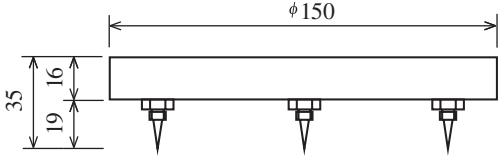
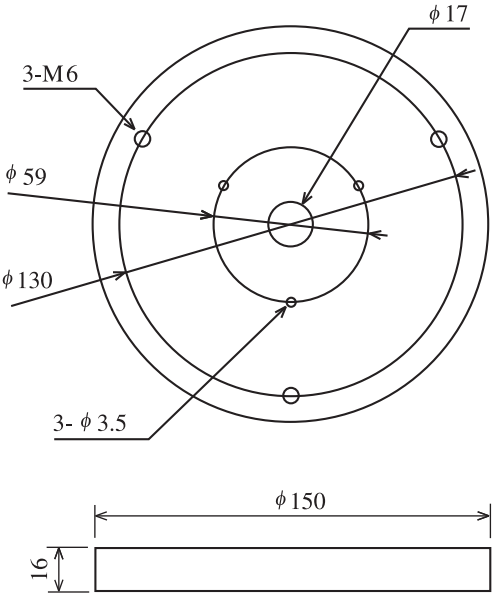

Attachment (spike feet)

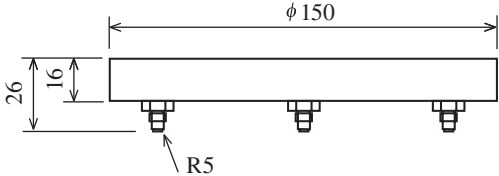

Attachment (round feet)

Unit: mm

Dimensional Drawing of DIN plate VP-54D

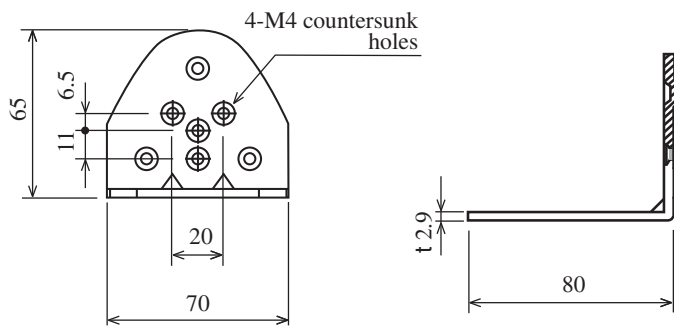

Unit: mm

Dimensional Drawing of L-bracket VP-54L

