

# Band/Barrel Heaters

Band/Barrel Heaters	Sheath Materials	Max. Operating Temperatures		Typical Max. Watt Densities		Page
		°F	°C	W/in <sup>2</sup>	W/cm <sup>2</sup>	
<b>Mineral Insulated (MI)</b>	Stainless steel	1400	760	100	15.5	<b>493</b>



Band/Barrel Heaters



# Band/Barrel Heaters

## Mineral Insulated (MI) Band Heaters

The mineral insulated (MI) band heater from Watlow® is a high-performance heater that incorporates Watlow's exclusive mineral insulation. This material offers much higher thermal conductivity than mica and hard ceramic insulators that are used in conventional heaters.

A thin layer of the "high" thermally conductive MI material electrically insulates the element wire from the inside diameter of the heater sheath. A thicker, low thermally conductivity layer backs up the element wire directing the heat inward toward the part being heated. The result is more efficient heat transfer, which lowers element wire temperatures and increases heater life.

### Performance Capabilities

- Heater operating temperatures up to 1400°F (760°C)
- Watt densities up to 100 W/in<sup>2</sup> (15.5 W/cm<sup>2</sup>) available on large diameter barrel bands
- Maximum voltage to 480V

### Features and Benefits

#### High thermal conductivity of MI and low mass construction

- Provides an almost instant response to temperature control
- Eliminates thermal lag and temperature overshoot associated with ceramic insulated heaters

#### Operating temperatures up to 1400°F (760°C)

- Allows safe melting of resins such as PEEK™, Teflon®, Ultem® and Zytel®

#### Higher watt densities

- Contributes to faster heat-up and throughput for increased productivity

#### Stainless steel cover and side fold design

- Resists contamination from overflow of plastic or other free-flowing materials

#### Attached clamp bars

- Eliminates cumbersome clamping straps to ease installation

### Typical Applications

- Extruders
- Blown film dies
- Injection molding machines
- Other cylinder heating applications

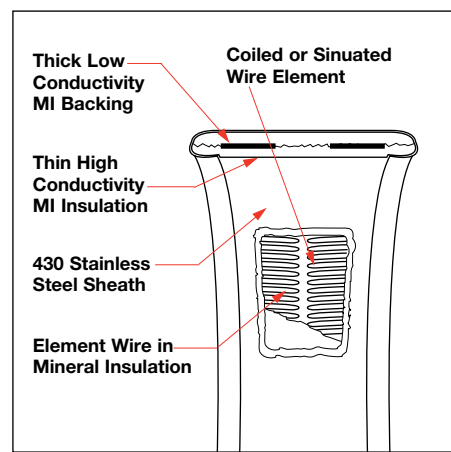

# Band/Barrel Heaters

## Mineral Insulated (MI) Band Heaters

### Applications and Technical Data

The *Physical Limitations of Variations* table shows the availability of widths, inside diameters and terminations for Watlow's MI band, barrel and nozzle heaters. To ensure available terminations meet application needs, refer to the termination variation illustrations in this section.

If the application requires a heater exceeding limitations shown, contact your Watlow representative.

### Physical Limitations of Variations

Width in. (mm)	I.D. Available – in. (mm)								Available Terminations
	1 pc. Construction Min. (mm) Max. (mm)		Expandable Min. (mm) Max. (mm)		2 pc. Construction Min. (mm) Max. (mm)				
1 (25)	1 (25) – 6 (152)	3 (76) – 12 (305)	3 (76) – 12 (305)	All					
1 <sup>3</sup> / <sub>8</sub> (35)	1 (25) – 3 (76)	3 (76) – 6 (152)	3 (76) – 6 (152)	All - Except SLE					
1 <sup>1</sup> / <sub>2</sub> (38)	1 (25) – 14 (356)	3 (76) – 14 (356)	3 (76) – 28 (711)	All					
2 (51)	1 <sup>1</sup> / <sub>4</sub> (32) – 14 (356)	3 (76) – 14 (356)	3 (76) – 28 (711)	All					
2 <sup>1</sup> / <sub>2</sub> (64)	1 <sup>1</sup> / <sub>4</sub> (32) – 14 (356)	3 (76) – 14 (356)	3 (76) – 28 (711)	All					
3 (76)	1 <sup>1</sup> / <sub>2</sub> (38) – 14 (356)	3 (76) – 14 (356)	3 (76) – 28 (711)	All					
3 <sup>1</sup> / <sub>2</sub> (89)	1 <sup>3</sup> / <sub>4</sub> (45) – 14 (356)	3 (76) – 14 (356)	3 (76) – 28 (711)	All - Except 90° "B" Leads					
4 (102)	2 (51) – 14 (356)	3 (76) – 14 (356)	3 (76) – 28 (711)	All					
4 <sup>1</sup> / <sub>2</sub> (114)	2 <sup>1</sup> / <sub>4</sub> (57) – 14 (356)	3 (76) – 14 (356)	3 (76) – 28 (711)	All					
5 (127)	2 <sup>1</sup> / <sub>2</sub> (64) – 14 (356)	3 (76) – 14 (356)	4 (102) – 28 (711)	All - Except 90° "B" Leads					
5 <sup>1</sup> / <sub>2</sub> (140)	2 <sup>3</sup> / <sub>4</sub> (70) – 14 (356)	3 (76) – 14 (356)	4 (102) – 28 (711)	Post Terminals, SLE only					
6 (152)	3 (76) – 14 (356)	3 (76) – 14 (356)	4 (102) – 28 (711)	All					
7 (178)		4 (102) – 14 (356)		Post Terminals, SLE only					

### General Limitations

- Maximum width of 1 in. (25 mm) diameter heater: 1<sup>1</sup>/<sub>2</sub> in. (38 mm)
- Maximum heater width: 2x heater diameter
- Minimum I.D. for Type B, C, E and H leads: 1 in. (25 mm)
- Minimum I.D. for Type B—90° leads: 1<sup>1</sup>/<sub>8</sub> in. (29 mm)
- Maximum lead amperes: 12.5A per pair
- SLE maximum: 17.0A
- Maximum amperes (post terminals): 30A per pair
- Minimum diameter and width for SLE: 4 in. x 1<sup>1</sup>/<sub>2</sub> in. (102 mm x 38 mm) width
- 90° leads not available over 250VAC
- Minimum I.D. for post terminals: 1<sup>1</sup>/<sub>4</sub> in. (32 mm)
- Actual width for 7 in. (178 mm) wide heater: 6<sup>7</sup>/<sub>8</sub> in. (175 mm)

### Gaps

- ≤ 3 in. = 1/8 in. nominal
- 3 in. ≤ 6 in. = 1/4 in. nominal ±1/8 in.
- 6 in. ≤ 14 in. = 3/8 in. nominal ±1/8 in.
- >14 in. = 1/2 in. nominal ±1/4 in.

# Band/Barrel Heaters

## Mineral Insulated (MI) Band Heaters

### Applications and Technical Data (Continued)

#### Calculating Watt Density

Watt density is the amount of wattage per square inch of heated area. To determine watt density, divide the total wattage by the heated area.

$$\text{Watt Density} = \frac{\text{Total Watts}}{\text{Heated Area}}$$

To apply this equation, the term “heated area” must be defined. Heated area is the total contact surface of the heater less the areas of no-heat found around terminals, mounting holes, etc.

**Heated Area = Total Contact Area - No-Heat Area**

To calculate the heated area:

1. Locate the **no-heat factor** from the chart below that corresponds to the type of heater being considered.

Type	No-Heat Factor in.
1 pc. lead unit Type B, C, H, E or 90°B	1.37
1 pc. post terminal	1.60
1 pc. expandable post term	3.18
1 pc. expandable lead unit	3.00
True 2 pc. post term	3.20
True 2 pc. leads	2.74
SLE	3.68

2. To use the formula below, insert the no-heat factors, diameter and width (in inches).

$$\text{Heated Area} = (3.14 \times \text{Diameter} - \text{No-Heat Factor}) \times \text{Width}$$

#### Maximum Allowable Watt Density

The following derating factors apply to the *Maximum Allowable Watt Density* chart, which are displayed in both inches and millimeters. Review these factors and the chart to determine the correct watt density curve for the application.

#### Derating Factors:

- For units over 2 in. (51 mm) in width, multiply the watt density by 0.80.

- For applications where unusual operating conditions are present, such as irregular mounting surfaces, contact your Watlow representative for watt density limitations.
- For two-piece units used in vertical applications, refer to *Clamping Matrix Application Guide* on page 496.
- For applications where insulating blankets are used, multiply watt density by 0.75.

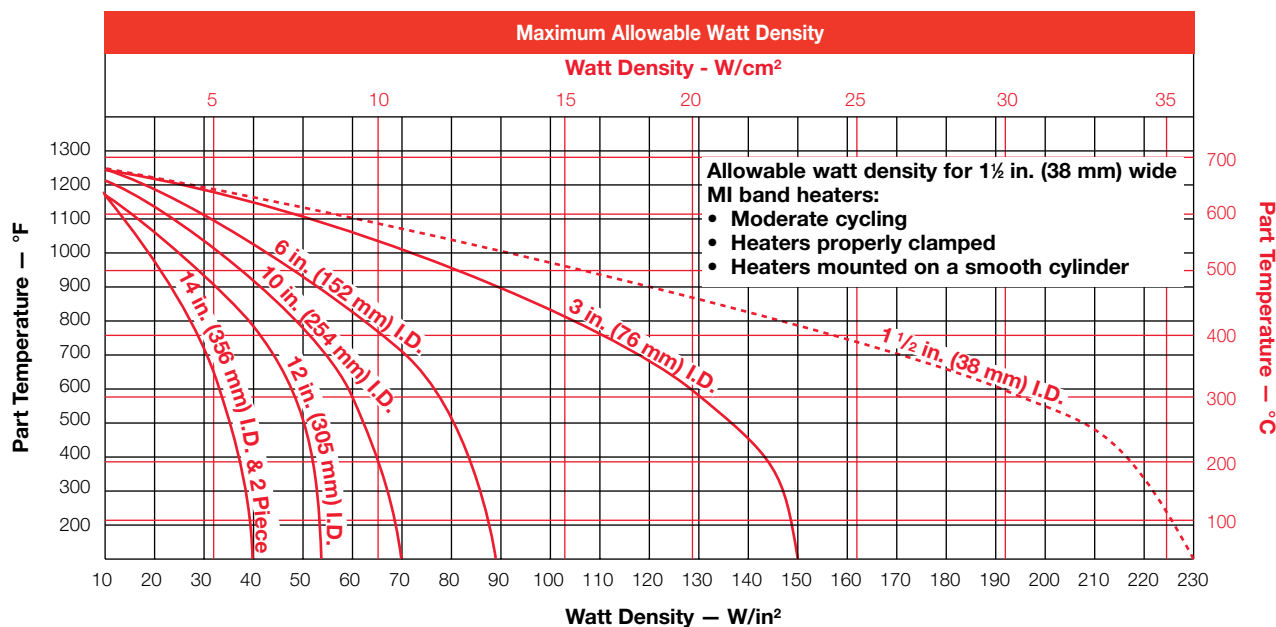

# Band/Barrel Heaters

## Mineral Insulated (MI) Band Heaters

### Applications and Technical Data (Continued)

- Review the *Watt Density* chart to ensure the application does not exceed the maximum watt density at operating temperature after applying derating factors.
- Locate clamping guideline for unit diameter, width and watt density.
- Description of guideline letters are at the bottom of the *MI Band Clamping Matrix Application Guide*.
- Note:** Upward arrows are up to and not including specified watt density. Downward arrows are greater than or equal to specified watt density.

**MI Band Clamping Matrix Application Guide**

Watt Density-W/in <sup>2</sup>	8 ≥ 10		10 ≥ 12		12 ≥ 14		14 ≥ 16		16 ≥ 18		18 ≥ 20		20 ≥ 22		22 ≥ 24		24 ≥ 26		26 ≥ 28	
	1 1/2 to 4 in. (38 to 102 mm)	4 1/2 to 7 in. (114 to 178 mm)	1 1/2 to 4 in. (38 to 102 mm)	4 1/2 to 7 in. (114 to 178 mm)	1 1/2 to 4 in. (38 to 102 mm)	4 1/2 to 7 in. (114 to 178 mm)	1 1/2 to 4 in. (38 to 102 mm)	4 1/2 to 7 in. (114 to 178 mm)	1 1/2 to 4 in. (38 to 102 mm)	4 1/2 to 7 in. (114 to 178 mm)	1 1/2 to 4 in. (38 to 102 mm)	4 1/2 to 7 in. (114 to 178 mm)	1 1/2 to 4 in. (38 to 102 mm)	4 1/2 to 7 in. (114 to 178 mm)	1 1/2 to 4 in. (38 to 102 mm)	4 1/2 to 7 in. (114 to 178 mm)	1 1/2 to 4 in. (38 to 102 mm)	4 1/2 to 7 in. (114 to 178 mm)	1 1/2 to 4 in. (38 to 102 mm)	4 1/2 to 7 in. (114 to 178 mm)
80																				
75																				
70																				
65	B																			
60																				
55		B																		
50			B																	
45				B																
40					B															
35						B														
30	A						D													
25		A						D												
20			A						D											
15				A						D										
10					A						D									
5						A						D								
0							A						D							

Above Recommended Watt Densities  
Contact your Watlow Representative

A = Clamp bars, expandable or one piece construction  
 B = Spring clamps, expandable or one piece construction  
 C = Spring clamps, at one gap, welded barrel nuts at other gap  
 D = Spring clamps, spring clamps at both gaps

**Width**      **Clamp Points at Each Gap**

≥ 5 in. (127 mm)      3

≥ 3 in. (76 mm)      2

< 3 in. (76 mm)      1

**Note:** 1 in. (25 mm) wide heaters use welded barrel nuts rather than clamp bars.

# Band/Barrel Heaters

## Mineral Insulated (MI) Band Heaters

### Termination Variations

#### Post Terminals

##### Stock

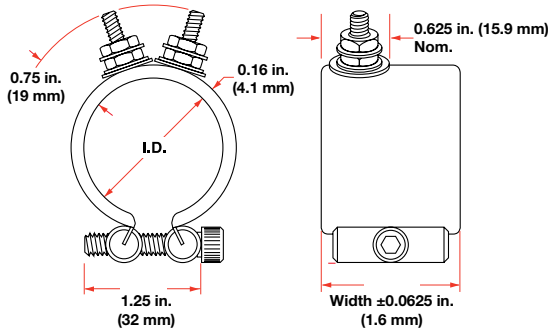

Post terminals provide optimum connections. Screw thread is 10-24. To order, specify **post terminals** (metric threads available).

#### Lead Wire

Heaters rated at less than 250VAC use UL<sup>®</sup> approved lead insulation for operations to 480°F (250°C) as standard. Lead insulation UL<sup>®</sup> rated for operation to 840°F (450°C) is available for high-temperature applications where the leads are shrouded or enclosed with the heater. These leads are available in any of the Type B with loose braid as well as Types E, F and H lead configurations. All heaters rated at more than 250VAC use this wire. When ordering, specify **850°F (450°C) wire**.

Leads Type B, Type B - 90° rotation, Type B - 180° rotation or Type C: Two fiberglass-insulated lead wires exit in a single metal braid for good abrasion protection, lead flexibility and wiring convenience. Leads are 2 in. (51 mm) longer than braid. Shipped with 12 in. (305 mm) leads, unless longer length is specified. To order, specify **type and length**.

#### Type B - 90° Rotation

##### Non-Stock

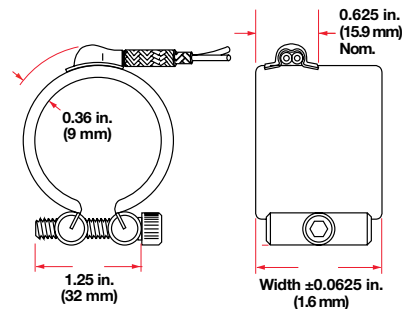

#### Type B - 180° Rotation

##### Stock

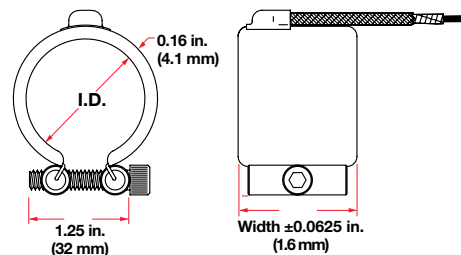

#### Type B

##### Stock

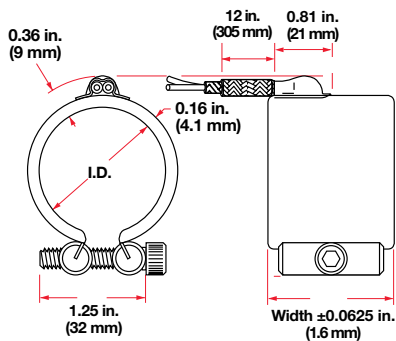

# Band/Barrel Heaters

## Mineral Insulated (MI) Band Heaters

### Termination Variations (Continued)

#### Lead Wire (Continued)

##### Type C Stock

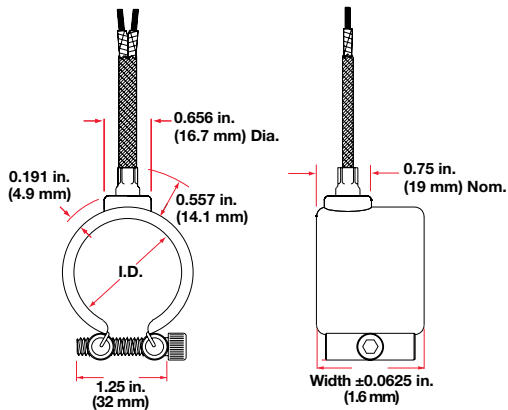

##### Type F Stock

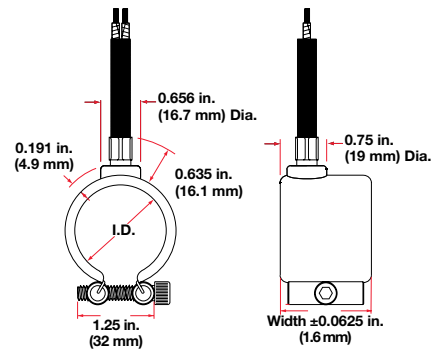

Type F: Loose fiberglass sleeving encloses two fiberglass leads for additional insulation protection where high temperature or minor abrasion is present. Leads are 2 in. (51 mm) longer than the sleeving. To order, specify **Type F** and **length**.

##### Type E Stock

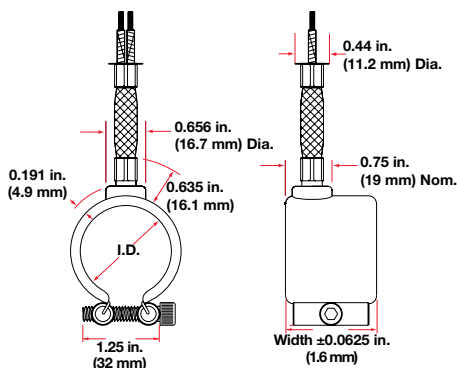

Type E: Loose metal braid encloses two fiberglass leads for good abrasion protection, lead flexibility and wiring convenience. Leads are 2 in. (51 mm) longer than the braid. Shipped with 12 in. (305 mm) leads, unless longer length is specified. To order, specify **Type E** and **length**.

##### Type H Stock

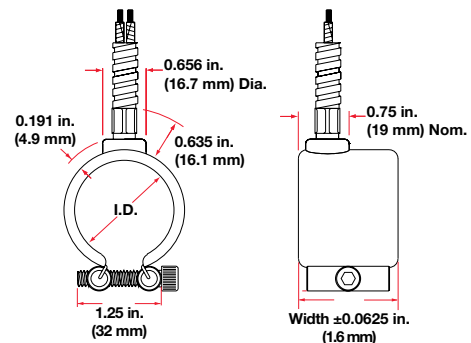

Type H: A flexible steel hose encloses the leads for maximum abrasion protection. Leads are 2 in. (51 mm) longer than hose. Shipped with 12 in. (305 mm) leads, unless longer length is specified. To order, specify **Type H** and **length**.

# Band/Barrel Heaters

## Mineral Insulated (MI) Band Heaters

### Termination Variations (Continued)

#### Lead Wire (Continued)

##### Type K Stock

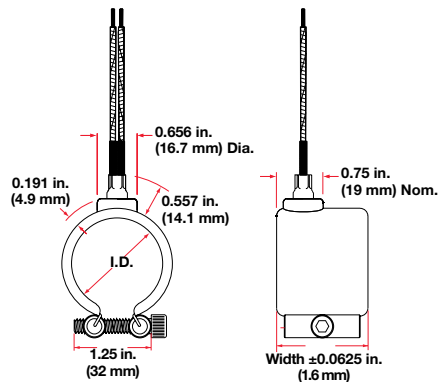

Type K: Flexible lead wires exit vertically from the heater. These leads can be bent adjacent to the heater for a quick and easy connection. To order, specify **Type K** and **length**.

##### Type SLE

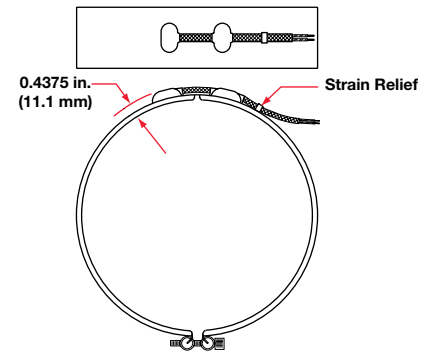

Two fiberglass lead wires exit a single, tightly woven metal braid at a right angle on the expandable construction vs. two sets of leads. The minimum diameter capability is 4 in. (102 mm). Minimum width capability is 1<sup>1</sup>/<sub>2</sub> in. (38 mm). To order, specify **Type SLE** and **length**.

## Variations

### Thermocouple

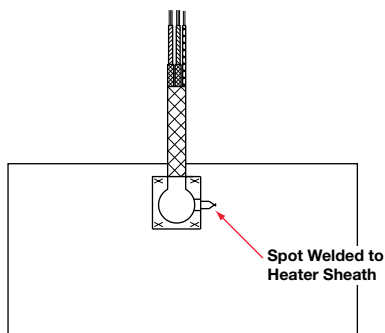

ASTM Type J or K thermocouples are available on lead Type B with loose braid and fiberglass sleeving. They are also available on E, F and H leads. The thermocouple junction, spot-welded to the heater sheath, provides a signal for measuring relative heater temperature. A separate thermocouple is available.

### Heavy Duty Strain Relief

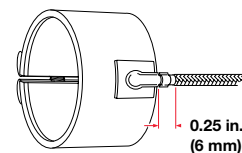

Heavy duty strain relief is recommended for applications where there is great stress or continued flexing of the leads. The strain relief is available on Type B, Type B - 90° and Type B - 180° leads only. To order, specify **heavy-duty strain relief**. **Note:** not available with loose braid or fiberglass sleeving.

# Band/Barrel Heaters

## Mineral Insulated (MI) Band Heaters

*Variations (Continued)*

### Expandable Heaters With Post Terminals or Leads

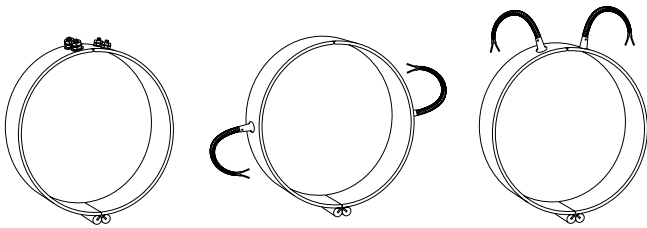

Expandable heaters are two-piece units with a common top metal allowing the heater to expand open to the full diameter of the barrel. On expandable bands, each half will be one half of the total wattage. Plus, on both expandable and two-piece bands, each half will be rated at full operating voltage, unless otherwise specified.

**MI band heaters 1<sup>1</sup>/<sub>2</sub> in. (38 mm) wide** or greater have post terminals located next to the expansion joint. Leads may be located anywhere along the circumference except near the gap and at the expansion joint. Two sets of leads required.

**On 1 in. (25 mm) wide** MI band heaters, post terminals will be located 90° from the expansion joint. Leads may be located anywhere along the circumference except near the gap and at the expansion joint. Two sets of leads are required. To order, specify **expandable**. Expandable heaters are designed to be opened for new installation only.

### Ceramic Terminal Cover

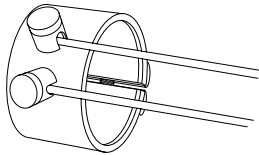

Ceramic covers, with openings for leads, are screwed on to post terminals, providing a convenient, economical insulator. To order, specify part number **Z-4918** and **quantity**. For metric sizes specify thread needed.

**Note:** Ceramic terminal covers will not fit on some stock expandable MI bands or nozzles. Contact your Watlow representative for more information.

### Metallic Terminal Box

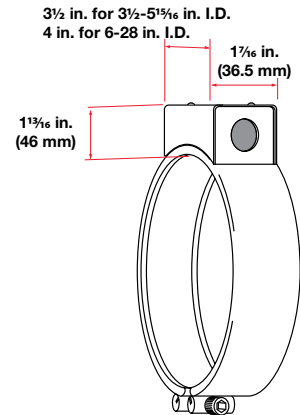

Metallic terminal boxes are available from stock on 3<sup>1</sup>/<sub>2</sub> in. inside diameter x 1<sup>1</sup>/<sub>2</sub> in. wide (89 mm x 38 mm) or larger heaters. Terminal boxes, which attach directly to the heater, act as a safety feature by covering the terminals. Conduit may be attached to the box through <sup>7</sup>/<sub>8</sub> in. (22 mm) diameter holes in the ends of the box. Two-piece heaters require two boxes. To order, specify **terminal box**.

### MI Band Heater with Holes

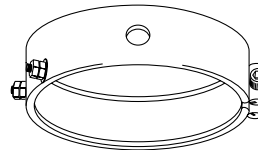

MI band heaters with holes are available on all widths except 1 in. (25 mm) wide. Contact your Watlow representative for hole sizes and location constraints. To order, specify **hole size** and **location**. The inside diameter minimum is 3 in. (76 mm). **Note:** a minimum charge per line item applies.

# Band/Barrel Heaters

## Mineral Insulated (MI) Band Heaters

### Clamping Variations

#### Tig-Welded Barrel Nuts with Spring Loaded Clamping

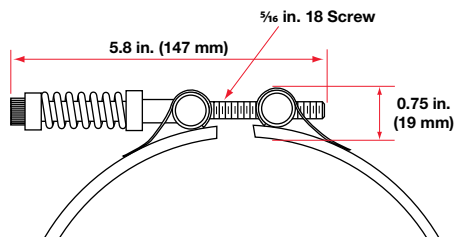

Welded barrel nuts with spring loaded clamping are used to maintain a tight heater fit on large barrels during start-up. This clamping variation is recommended for all MI band heaters greater than 14 in. (356 mm) in diameter and 1 1/2 in. (38 mm) or greater in width. Refer to *MI Band Clamping Matrix Application Guide*. For smaller diameter heaters, it is an option and must be ordered separately. To order, specify **spring loaded clamping**.

#### Low-Profile Tig-Welded Barrel Nuts

Low-profile barrel nuts are available on all widths and provide a clearance of 0.470 in. (12 mm). However, this value can be higher depending on how far the clamp screw extends past the barrel nut. To order, specify **low-profile tig-welded barrel nuts**.

#### Low-Profile Clamp Bars

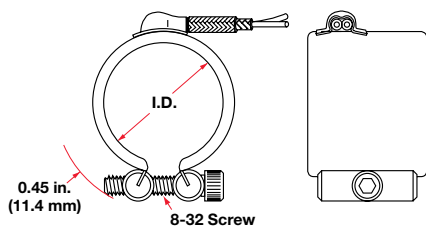

Low-profile clamp bars are available on both 1 in. (25 mm) and 1 1/2 in. (38 mm) wide heaters, for wider widths contact your Watlow representative. Watlow recommends not using low-profile clamping on diameters and widths greater than 3 in. (76 mm). The bars are 1/4 in. (6 mm) diameter with an 8-32 screw. To order, specify **low-profile clamp bars**.

#### Tig-Welded Barrel Nuts

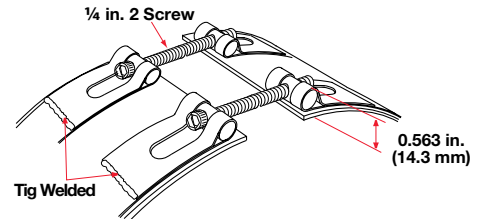

Tig-welded barrel nuts can function like a hinge to allow two-piece heaters to be more easily installed. If a large gap is specified to provide access for instrumentation, tig-welded barrel nuts can be situated in such a way that the clamp screws do not interfere with the sensor. To order, specify **gap size and sensor location**. **Note:** a gap greater than 1 in. (25 mm) wide is considered extended capability.

### Options

#### Thermocouple Pocket

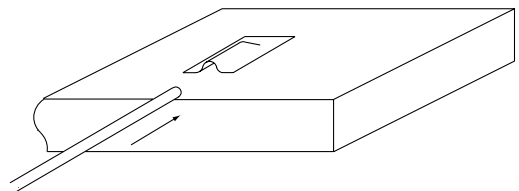

A thermocouple pocket welded to the surface accepts a 0.063 in. (2 mm) diameter thermocouple (not included). This option provides accurate temperature sensing of the heater and easy thermocouple replacement.

# Band/Barrel Heaters

EXTENDED  
CAPABILITY

## Extended Capabilities For Mineral Insulated (MI) Band Heaters

### Variations

#### High Temperature “Quick Disconnect” European Style Plugs

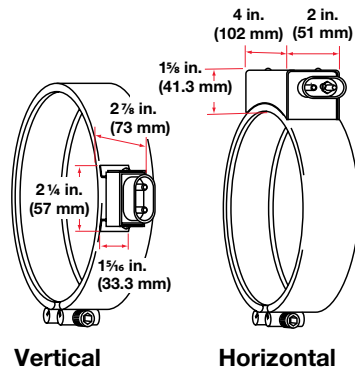

They provide the simplest and safest way to apply power to band heaters. The combination of high-temperature male and female “quick disconnect” plug assemblies eliminates all live exposed terminals and electrical wiring that can be a potential hazard to employees or machine. Maximum 15 amperes at 240VAC, maximum 240V. To order, specify **vertical** or **horizontal** European plug.

#### Ground Wire

Insulated ground wire is available, contact your Watlow representative.

#### Outside Diameter Heater

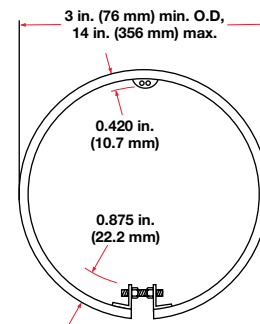

Two fiberglass-insulated lead wires rated to 840°F (450°C) exit a metal braid 180° opposite from gap, Type B outside diameter designed and constructed to mate with inside diameter of cylinders. Maximum width for outside diameter heaters is 6 in. (152 mm). To order, specify **outside diameter and width** of heater.

# Band/Barrel Heaters

## Mineral Insulated (MI) Band Heaters

### Heater Part Numbers

I.D. in. (mm)	Width in. (mm)	Construction	Volts	Watts	Watt Density		Termination	Approx. Net Wt.		Delivery	Part Number
					W/in <sup>2</sup>	(W/cm <sup>2</sup> )		lbs	(kg)		
1 (25)	1 (25)	1 pc	120	150	92	(14.2)	Type B,C,E, F or H	0.1	(0.05)	RS	<b>MB1A1AN1</b>
	1 (25)	1 pc	120	100	61	(9.4)	Type B,C,E, F or H	0.1	(0.05)	RS	<b>MB1A1AN2</b>
	1 (25)	1 pc	120	200	122	(18.9)	Type B,C,E, F or H	0.1	(0.05)	RS	<b>MB1A1AN3</b>
	1 (25)	1 pc	240	200	122	(18.9)	Type B,C,E, F or H	0.1	(0.05)	RS	<b>MB1A1AN4</b>
	1 1/2 (38)	1 pc	240	300	106	(16.4)	Type B,C,E, F or H	0.1	(0.05)	RS	<b>MB1A1JN1</b>
	1 1/2 (38)	1 pc	120	300	106	(16.4)	Type B,C,E, F or H	0.1	(0.05)	RS	<b>MB1A1JN2</b>
	1 1/2 (38)	1 pc	240	200	70	(10.8)	Type B,C,E, F or H	0.1	(0.05)	RS	<b>MB1A1JN3</b>
	1 1/2 (38)	1 pc	120	200	70	(10.8)	Type B,C,E, F or H	0.1	(0.05)	M	<b>MB1A1JN4</b>
	1 1/2 (38)	1 pc	240	400	141	(21.8)	Type B,C,E, F or H	0.1	(0.05)	RS	<b>MB1A1JN5</b>
1 1/4 (32)	1 (25)	1 pc	240	250	104	(16.1)	Type B,C,E, F or H	0.1	(0.05)	RS	<b>MB1E1AN1</b>
	1 (25)	1 pc	120	250	104	(16.1)	Type B,C,E, F or H	0.1	(0.05)	RS	<b>MB1E1AN2</b>
	1 (25)	1 pc	240	300	124	(19.2)	Type B,C,E, F or H	0.1	(0.05)	M	<b>MB1E1AN3</b>
	1 1/2 (38)	1 pc	240	350	87	(13.5)	Type B,C,E, F or H	0.2	(0.09)	RS	<b>MB1E1JN1</b>
	1 1/2 (38)	1 pc	120	350	87	(13.5)	Type B,C,E, F or H	0.2	(0.09)	RS	<b>MB1E1JN2</b>
	1 1/2 (38)	1 pc	240	450	112	(17.3)	Type B,C,E, F or H	0.2	(0.09)	M	<b>MB1E1JN3</b>
1 1/2 (38)	1 (25)	1 pc	240	300	93	(14.4)	Type B,C,E, F or H	0.1	(0.05)	M	<b>MB1J1AN1</b>
	1 (25)	1 pc	120	300	93	(14.4)	Type B,C,E, F or H	0.1	(0.05)	RS	<b>MB1J1AN2</b>
	1 (25)	1 pc	240	200	62	(9.6)	Type B,C,E, F or H	0.1	(0.05)	RS	<b>MB1J1AN3</b>
	1 (25)	1 pc	120	200	62	(9.6)	Type B,C,E, F or H	0.1	(0.05)	RS	<b>MB1J1AN4</b>
	1 (25)	1 pc	240	400	125	(19.3)	Type B,C,E, F or H	0.1	(0.05)	RS	<b>MB1J1AN5</b>
	1 1/2 (38)	1 pc	120	300	62	(9.6)	Type B,C,E, F or H	0.2	(0.09)	RS	<b>MB1J1JN1</b>
	1 1/2 (38)	1 pc	240	450	87	(13.5)	Type B,C,E, F or H	0.2	(0.09)	RS	<b>MB1J1JN2</b>
	1 1/2 (38)	1 pc	240	300	62	(9.6)	Type B,C,E, F or H	0.2	(0.09)	RS	<b>MB1J1JN3</b>
	1 1/2 (38)	1 pc	240	600	116	(17.9)	Type B,C,E, F or H	0.2	(0.09)	M	<b>MB1J1JN4</b>
	1 1/2 (38)	1 pc	240	300	62	(9.6)	Post	0.2	(0.09)	M	<b>MB1J1JP4</b>
	1 1/2 (38)	1 pc	240	450	96	(14.8)	Post	0.2	(0.09)	RS	<b>MB1J1JP6</b>
	2 (51)	1 pc	240	450	57	(8.8)	Type B,C,E, F or H	0.3	(0.14)	RS	<b>MB1J2AN1</b>
	2 (51)	1 pc	240	300	42	(6.5)	Type B,C,E, F or H	0.3	(0.14)	RS	<b>MB1J2AN2</b>
	2 (51)	1 pc	240	900	125	(19.3)	Type B,C,E, F or H	0.3	(0.14)	RS	<b>MB1J2AN3</b>
	3 (76)	1 pc	240	500	45	(7.0)	Type B,C,E, F or H	0.4	(0.18)	RS	<b>MB1J3AN1</b>
	3 (76)	1 pc	240	350	31	(4.8)	Type B,C,E, F or H	0.4	(0.18)	M	<b>MB1J3AN2</b>
3 (76)	1 pc	240	1000	104	(16.1)	Type B,C,E, F or H	0.4	(0.18)	M	<b>MB1J3AN3</b>	
1 3/4 (45)	1 3/8 (35)	1 pc	240	450	83	(12.9)	36 in. 90° Type B braid w/HD strain relief	0.2	(0.09)	RS	<b>MB1N1GX3A</b>
	1 1/2 (38)	1 pc	240	300	47	(7.3)	Type B,C,E, F or H	0.2	(0.09)	RS	<b>MB1N1JN1</b>
	1 1/2 (38)	1 pc	120	300	50	(7.7)	Type B,C,E, F or H	0.2	(0.09)	RS	<b>MB1N1JN2</b>
	1 1/2 (38)	1 pc	240	700	110	(17.0)	Type B,C,E, F or H	0.2	(0.09)	RS	<b>MB1N1JN3</b>
	2 (51)	1 pc	240	750	86	(13.3)	Type B,C,E, F or H	0.3	(0.14)	M	<b>MB1N2AN1</b>
2 (51)	1 (25)	1 pc	240	350	73	(11.3)	Type B,C,E, F or H	0.2	(0.09)	RS	<b>MB2A1AN1</b>
	1 (25)	1 pc	120	350	73	(11.3)	Type B,C,E, F or H	0.2	(0.09)	RS	<b>MB2A1AN2</b>
	1 (25)	1 pc	240	450	94	(14.5)	Type B,C,E, F or H	0.2	(0.09)	RS	<b>MB2A1AN3</b>
	1 (25)	1 pc	240	350	73	(10.3)	36 in. 90° Type B braid w/HD strain relief	0.2	(0.09)	RS	<b>MB2A1AX6B</b>

CONTINUED

**RAPID SHIP**

- **RS** - Next day shipment
- **M** - Manufacturing lead times

**Notes:**

All lead units are available with any length Type B, C, E, F or Type H leads. Type B 90° rotation not available as RAPID SHIP.

# Band/Barrel Heaters

## Mineral Insulated (MI) Band Heaters

### Heater Part Numbers (Continued)

I.D. in. (mm)	Width in. (mm)	Construction	Volts	Watts	Watt Density		Termination	Approx. Net Wt.		Delivery	Part Number
					W/in <sup>2</sup>	(W/cm <sup>2</sup> )		lbs	(kg)		
2 (51)	1 1/2 (38)	1pc	240	400	53	(8.2)	Type B,C,E, F or H	0.3	(0.14)	RS	<b>MB2A1JN1</b>
	1 1/2 (38)	1pc	240	1000	132	(20.4)	Type B,C,E, F or H	0.3	(0.14)	M	<b>MB2A1JN2</b>
	2 (51)	1pc	240	750	75	(11.6)	Type B,C,E, F or H	0.4	(0.18)	M	<b>MB2A2AN1</b>
	2 (51)	1pc	240	1200	125	(19.3)	Type B,C,E, F or H	0.4	(0.18)	RS	<b>MB2A2AN2</b>
	2 (51)	1pc	240	750	75	(11.6)	36 in. 90° Type B braid w/HD strain relief	0.2	(0.09)	RS	<b>MB2A2AX2A</b>
2 1/4 (57)	2 (51)	1pc	240	750	63	(9.7)	120 in. 180° Type B braid w/HD strain relief	0.2	(0.09)	RS	<b>MB2E2AX7</b>
	2 1/2 (64)	1 pc	240	1000	72	(11.2)	Type B,C,E, F or H	0.5	(0.23)	RS	<b>MB2E2JN1</b>
2 1/2 (64)	1 (25)	1 pc	240	400	63	(9.7)	Type B,C,E, F or H	0.2	(0.09)	RS	<b>MB2J1AN1</b>
	1 1/2 (38)	1 pc	240	500	50	(7.7)	Type B,C,E, F or H	0.4	(0.18)	RS	<b>MB2J1JN1</b>
3 (76)	1 (25)	1 pc	240	400	54	(8.4)	Post	0.3	(0.14)	M	<b>MB3A1AP1</b>
	1 1/2 (38)	1 pc	240	500	40	(6.2)	Post	0.4	(0.18)	RS	<b>MB3A1JP1</b>
	1 1/2 (38)	2 pc exp	230/460	525	53	(8.2)	Post	0.4	(0.18)	M	<b>ME3A1JP10</b>
3 1/2 (89)	2 (51)	1 pc	240	800	42	(6.5)	Post	0.7	(0.32)	RS	<b>MB3J2AP2</b>
3 5/8 (92)	1 1/2 (38)	2 pc exp	230/460	650	51	(7.9)	Post	0.5	(0.23)	M	<b>ME3L1JP5</b>
4 (102)	1 (25)	1 pc	240	700	62	(9.6)	Post	0.4	(0.18)	RS	<b>MB4A1AP1</b>
	1 1/2 (38)	1 pc	240	800	48	(7.4)	Post	0.6	(0.27)	RS	<b>MB4A1JP2</b>
	1 1/2 (38)	2 pc exp	230/460	625	43	(6.7)	Post	0.6	(0.27)	RS	<b>ME4A1JP11</b>
	1 1/2 (38)	2 pc exp	230/460	725	50	(7.8)	Post	0.6	(0.27)	RS	<b>ME4A1JP12</b>
4 1/2 (114)	2 1/2 (64)	1pc	240	1250	40	(6.2)	Post	1.0	(0.45)	RS	<b>MB4J2JP1</b>
5 (127)	1 1/2 (38)	2 pc exp	240/480	1000	52	(8.1)	Post	0.8	(0.36)	RS	<b>MB5A1JP8</b>
5 1/4 (133)	1 1/2 (38)	2 pc exp	240/480	1000	48	(7.4)	Post	0.8	(0.36)	M	<b>ME5E1JP1</b>
	1 1/2 (38)	2 pc exp	230/460	600	29	(4.5)	Post	0.7	(0.32)	M	<b>ME5E1JP9</b>
	3 (76)	2 pc exp	230/460	1700	40	(6.2)	Post	1.5	(0.68)	RS	<b>ME5E3AP5</b>
	4 1/2 (114)	2 pc exp	230/460	2400	38	(5.9)	Post	2.2	(1.00)	RS	<b>ME5E4JP2</b>
	4 1/2 (114)	2 pc exp	230/460	2700	43	(6.6)	Post	2.2	(1.00)	M	<b>ME5E4JP3</b>
5 1/2 (140)	1 1/2 (38)	2 pc exp	240/480	1000	46	(7.1)	Post	0.9	(0.40)	RS	<b>ME5J1JP1</b>
6 (152)	1 1/2 (38)	2 pc exp	240/480	1000	41	(6.4)	Post	0.9	(0.40)	M	<b>ME6A1JP2</b>
6 1/2 (165)	1 1/2 (38)	2 pc exp	240/480	1250	47	(7.3)	Post	1.0	(0.45)	RS	<b>ME6J1JP5</b>
6 3/4 (171)	1 1/2 (38)	2 pc exp	230/460	815	29	(4.5)	Post	0.9	(0.40)	M	<b>ME6N1JP6</b>
	1 1/2 (38)	2 pc exp	230/460	1000	36	(5.6)	Post	0.9	(0.40)	M	<b>ME6N1JP7</b>
	4 (102)	2 pc exp	230/460	2600	35	(5.4)	Post	2.5	(1.10)	M	<b>ME6N4AP2</b>
	5 (127)	2 pc exp	230/460	3700	40	(6.2)	Post	3.2	(1.50)	M	<b>ME6N5AP3</b>
	6 (152)	2 pc exp	230/460	3750	33	(5.1)	Post	3.8	(1.70)	M	<b>ME6N6AP5</b>
7 (178)	1 1/2 (38)	2 pc exp	240/480	1250	43	(6.6)	Post	1.1	(0.50)	M	<b>ME7A1JP4</b>
7 1/2 (191)	1 1/2 (38)	2 pc exp	240/480	1500	47	(7.3)	Post	1.1	(0.50)	M	<b>ME7J1JP4</b>
7 5/8 (194)	3 (76)	2 pc exp	230/460	1800	28	(4.3)	Post	2.2	(1.00)	M	<b>ME7L3AP1</b>
8 (203)	1 1/2 (38)	2 pc exp	240/480	1250	37	(5.7)	Post	1.2	(0.54)	M	<b>ME8A1JP4</b>
9 (229)	1 1/2 (38)	2 pc exp	240/480	1500	39	(6.0)	Post	1.4	(0.64)	M	<b>ME9A1JP1</b>
9 1/2 (241)	3 (76)	2 pc exp	230/460	3000	37	(5.7)	Post	2.6	(1.20)	M	<b>ME9J3AP2</b>
11 1/4 (286)	3 (76)	2 pc exp	230/460	2400	24	(3.7)	Post	3.2	(1.50)	M	<b>ME11E3AP2</b>
	5 (127)	2 pc exp	230/460	5100	31	(4.8)	Post	5.2	(2.40)	M	<b>ME11E5AP1</b>

**RAPID SHIP**

- RS - Next day shipment
- M - Manufacturing lead times

**Notes:**

All lead units are available with any length Type B, C, E, F or Type H leads. Type B 90° rotation not available as RAPID SHIP.