

Technical Note

Duct Mount Adapters

1998-0880 Rev 1
September 2014

For Duct Mounting XCD-RTD, XCD-RFD, Sensepoint Toxic, Sensepoint Combustible, 705 and XNX w/705

Duct Mounting Kit 1283-1047

The duct mounting assembly allows installation of sensors directly into ducts with diameters from 3 to 16 inches (8 to 40 cm). The installation uses a minimum number of holes drilled into the ductwork, and allows quick changeover for exchanging sensors. (Refer to **Figure 1**)

This technical note provides installation instructions for mounting the sensor duct adapter. A hole diagram is shown in **Figure 3**.

The duct mounting adapter assembly is designed to divert 700cc of sample flow to a sensor over a wide variety of duct diameters and flow rates. For installations with high flow rates, an adjustable flow restrictor (included) is attached to the duct adapter. Use the charts (**Table 1**) to determine the restrictor settings. The restrictor adjustment settings are shown in **Figure 2**.

The duct mounting kit (P/N 1283-1047) includes the following:

Description	Part Number	Quantity
Sensor Duct Adapter	1283-1048	1
Flow Restrictor	1283-1091	1
Washer, #8 Nylon	0950-0079	2
Gasket, #8 Sealing	105637	2
Screw, 8 x 3/4, self-tapping	0950-0080	2
O-ring, 7/8 I.D. x 1-1/8 O.D.	0235-1135	2*
O-ring, Sensor	0235-1130	2*
O-ring, Sensor	0235-1131	2*

*Only one item is required; kit contains a spare of this part.

Technical Note

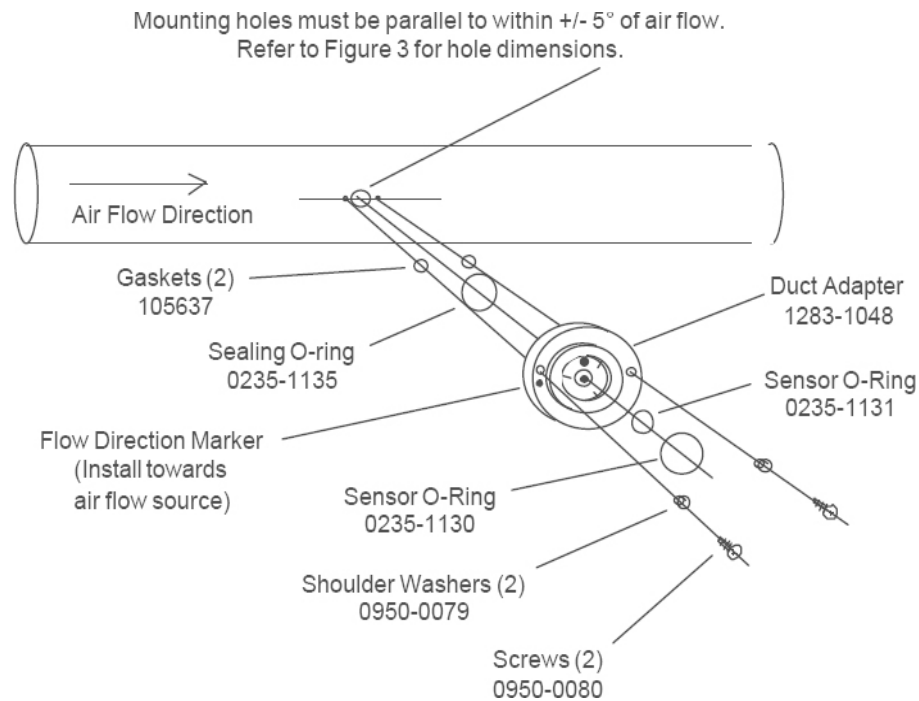

Figure 1 – Duct Mounting Adapter

Installation

Use the chart shown in **Table 1** to determine if you need to add the flow restrictor to the duct adapter. If you need the restrictor, install it onto the pitot tubes (the portion of the duct adapter that goes into the duct). Refer to **Figure 2**. The pitot tubes have scribed lines which represent Restrictor Lines A through C. Restrictor Line C offers the most restriction, and is the line closest to the end of the pitot tubes. Align the chamfered edge of the restrictor with the proper line before tightening the set screw. Also, make certain the set screw is downstream of the air flow.

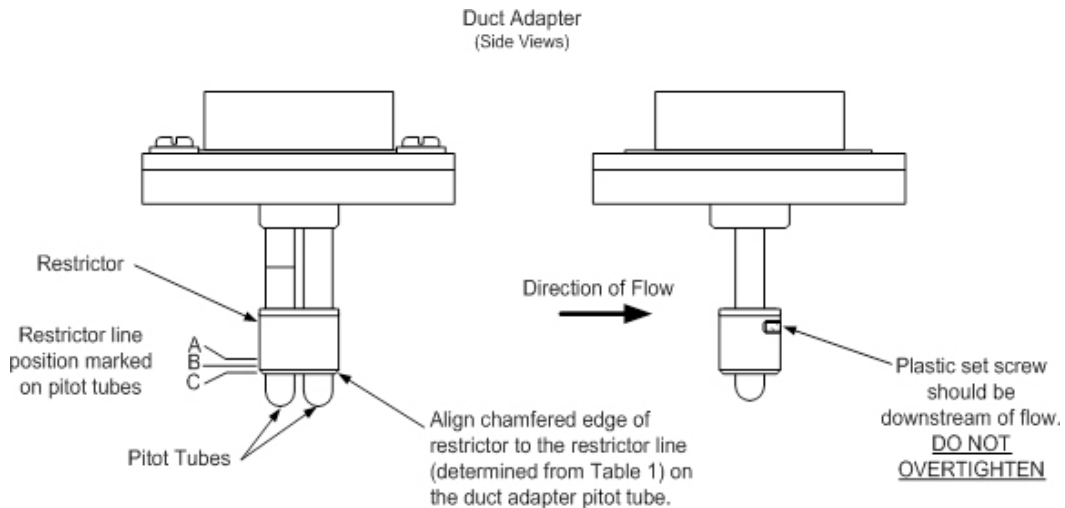

Figure 2 – Setting the Flow Restrictor

Technical Note

Duct mounting is simple. **Figure 3** shows the hole pattern. One 7/8-inch (22 mm) hole and two smaller 9/64-inch (3.6 mm) holes for #8 sheet metal screws are the only installation intrusion to the ductwork. The sheet metal screw holes must be parallel within $\pm 5^\circ$ of the direction of air flow in the duct.



Caution:

To prevent an earth loop, ensure the duct adapter center does not come in contact with metal ductwork. Use the O-rings and insulators provided in this kit.

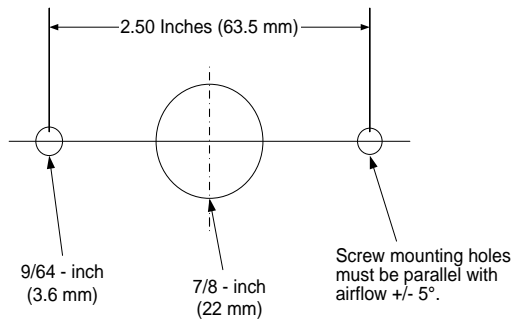

NOTE: This drawing is NOT TO SCALE

Figure 3 – Hole Diagram for Duct Mounting Adapter

If the flow in the duct is not known, you must connect a mass flowmeter to the duct adapter as shown in **Figure 4**. Do not use a rotometer or ballmeter.

Important: 1/4-inch tubing is required, and the total length should be less than 2 feet. Adjust the position of the restrictor until the flow is 700 cc/min, ± 100 cc/min.

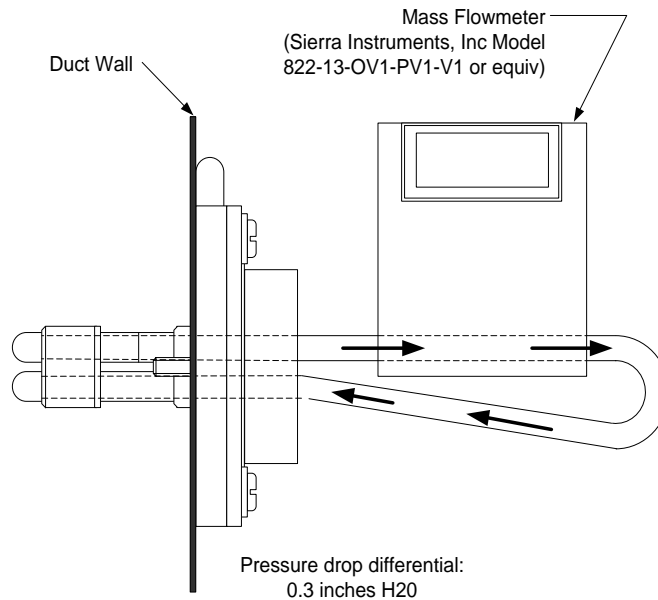

Figure 4 – Connecting a Mass Flowmeter to Duct Adapter

Technical Note

Connecting/Changing Sensors

When changing a duct-mounted sensor, twist the sensor counterclockwise 1/4-turn to release. Re-install per manual instructions.

Flow Performance

Sample transport time:	30 seconds or less
Sample flow rate:	0.6 – 1.2 Liters per minute
Velocity	Minimum: 735 ft/min (224 m/min)
	Maximum: 1024 ft/min (312 m/min)
Pipe flow:	Refer to Tables 1 and 2
Accuracy:	+/- 10%

Duct Mount Adapter 1283-1084

Overview

This adapter is an interface between duct adapter kit (P/N 1283-1047 described above) and the XCD-RFD, Sensepoint Combustible, 705 and XNX w/705 Detectors. The adapter includes a calibration port to allow gas testing. The adapter is shown in **Figure 5**.

How it Works

The adapter is a mechanical interface with the Sensor-style bayonet fitting on one end. This attaches directly to the sensor duct adapter. The other end of the adapter interface is threaded to mate with the XCD-RFD, Sensepoint Combustible, 705 and XNX w/705 sensors. A port on the side of the adapter allows direct attachment to tubing for calibration or live-gas challenges.



Figure 5 – Adapter Interface

Duct Flow Rate

The duct mounting adapter kit (1283-1047) is designed to divert sample flow to a sensor over a wide variety of duct diameters and flow rates. For installations with high flow rates, an adjustable flow restrictor (included) is attached to the duct adapter. Use the charts (**Table 2**) to determine the restrictor settings for use with the interface adapter and the hydrogen sensor.

Technical Note

Catalytic sensors are passive and they require no airflow for accurate and rapid gas response. Sensor airflow of 5 to 500 cc/min is required to ensure sufficient gas changeover inside the duct adapter. The orifice restrictor is used to limit the sensor airflow, in order to minimize the dilution of calibration gas that is introduced from the side port.

Refer to the duct adapter for XCD-RTD and Sensepoint Toxic Sensors shown above for more information about the restrictor settings. The restrictor adjustment settings are shown in **Figure 2** of the duct adapter technical note.

Installation

The duct adapter should be preinstalled in the ductwork. If it is not, refer to the instructions provided with the duct adapter for XCD-RTD and Sensepoint Toxic Sensors shown above.

Follow the preparation and installation instructions provided with the hydrogen sensor. Make certain the protective cap over the sensor inlet is removed before installation.

Ensure that the O-ring is in place on the threaded side of the adapter interface. Attach the threaded end of the adapter interface to the hydrogen sensor. Tighten the set screw on the adapter interface to secure the sensor.

Make certain that all the duct adapter O-rings are in place around the base of the center pitot tube. Insert the interface/sensor combination into the duct adapter. A clockwise one-quarter turn secures the components.

Figure 6 shows the completed assembly installed in a duct.

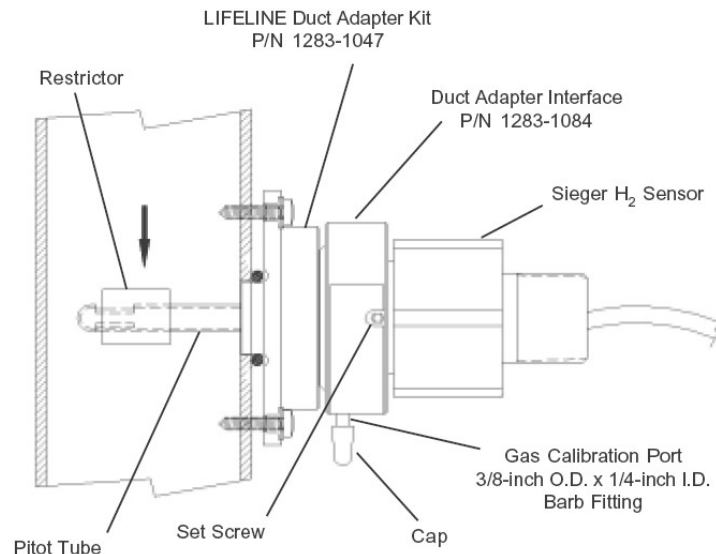

Figure 6 – Installed Assembly

Technical Note

Gas Calibration and Challenges

- Remove the cap on the interface adapter gas port.
- Connect and secure tubing from calibration gas bottle's regulator. The regulator should deliver 1 L/min.
- Open the gas valve on the calibration gas bottle to apply gas. Leave the gas on for 30 seconds to allow the sensor to stabilize.
- Calibrate the transmitter and/or controller.
- Shut off the calibration gas.
- Remove tubing and replace the cap on the adapter's gas calibration port.

Duct Adapter Restriction Setting Tables

Duct Adapter Restrictor Settings for Sensepoint and XCD-RTD Electrochemical Sensors					
Duct Diameter	Duct Flow Rate (CFM)				
	Not Recommended*	No Restrictor	Set to Line A	Set to Line B	Set to Line C
3 Inches	<15	15-50	50-75	75-100	100-130
4 inches	< 65	65-90	90-130	130-180	180-220
6 inches	< 145	145-200	200-300	300-400	400-500
8 inches	< 260	260-360	360-500	500-725	725-875
10 inches	< 400	400-560	560-800	800-1125	1125-1400
12 inches	< 575	575-800	800-1200	1200-1600	1600-2000
14 inches	< 790	790-1100	1100-1550	1550-2200	2200-2700
16 inches	<1025	1025-1430	1430-2000	2000-2900	2900-3500

* Consult Honeywell Analytics for recommendation.

Table 1 – Determining Restrictor Settings

Duct Adapter Restrictor Settings for XCD-RFD, 705, Sensepoint Combustible, and XNX w/705 Sensors					
Duct Diameter	Duct Flow Rate (CFM)				
	Not Recommended	No Restrictor	Set to Line A	Set to Line B	Set to Line C
3 Inches	<10	10-50	50-75	75-100	100-130
4 Inches	<25	25-90	90-130	130-180	180-220
6 Inches	<50	50-200	200-300	300-400	400-500
8 Inches	<90	90-360	360-500	500-725	725-875
10 Inches	<140	140-560	560-800	800-1125	1125-1400
12 Inches	<200	200-800	800-1200	1200-1600	1600-2000
14 Inches	<275	275-2000	2000-1550	1550-2200	2200-2700
16 Inches	<360	360-1430	1430-2000	2000-2900	2900-3500

* Low flow rates cause a delay in gas response. Consult Honeywell Analytics for flows under the recommended minimums.

Table 2 – Determining Restrictor Settings

Technical Note

Find out more

www.honeywellanalytics.com

Contact Honeywell Analytics:

Americas

Honeywell Analytics Inc.
405 Barclay Blvd.
Lincolnshire, IL 60069
USA

Tel: +1 847 955 8200
Toll free: +1 800 538 0363
Fax: +1 847 955 8210

detectgas@honeywell.com

Europe, Middle East, Africa

Life Safety Distribution AG
Javastrasse 2
8640 Hegnau
Switzerland

Tel: +41 (0)44 943 4300
Fax: +41 (0)44 943 4398

gasdetection@honeywell.com

Asia Pacific

Honeywell Analytics Asia Pacific
#508, Kolon Science Valley (I)
187-10 Guro-Dong, Guro-Gu
Seoul, 152-050
Korea

Tel: +82 (0)2 2025 0307
Fax: +82 (0)2 2025 0329

analytics.ap@honeywell.com

Technical Services

ha.us.service@honeywell.com

www.honeywell.com

While every effort has been made to ensure accuracy in this publication, no responsibility can be accepted for errors or omissions. Data may change, as well as legislation, and you are strongly advised to obtain copies of the most recently issued regulations, standards and guidelines. This publication is not intended to form the basis of a contract and the company reserves the right to amend the design and specification without notice.