

PanaFlow™ XMT1000

User's Manual



PanaFlow™ XMT1000

Panametrics Liquid Flow Ultrasonic Transmitter

User's Manual

BH054C11 EN B
April 2024

panametrics.com

Copyright 2024 Baker Hughes company.

This material contains one or more registered trademarks of Baker Hughes Company and its subsidiaries in one or more countries. All third-party product and company names are trademarks of their respective holders.

[no content intended for this page]

Services



Panametrics provides customers with an experienced staff of customer support personnel ready to respond to technical inquiries, as well as other remote and on-site support needs. To complement our broad portfolio of industry-leading solutions, we offer several types of flexible and scalable support services including: Training, Product Repairs, Service Agreements and more.

Please visit <https://www.bakerhughes.com/panametrics/panametrics-services> for more details.

Typographical Conventions

Note: These paragraphs provide information that provides a deeper understanding of the situation, but is not essential to the proper completion of the instructions.

IMPORTANT: These paragraphs provide information that emphasizes instructions that are essential to proper setup of the equipment. Failure to follow these instructions carefully may cause unreliable performance.



CAUTION! This symbol indicates a risk of potential minor personal injury and/or severe damage to the equipment, unless these instructions are followed carefully.



WARNING! This symbol indicates a risk of potential serious personal injury, unless these instructions are followed carefully.

Safety Issues



WARNING! It is the responsibility of the user to make sure all local, county, state and national codes, regulations, rules and laws related to safety and safe operating conditions are met for each installation.



Attention European Customers! To meet CE Marking requirements for all units intended for use in the EU, all electrical cables must be installed as described in this manual.

Auxiliary Equipment

Local Safety Standards

The user must make sure that he operates all auxiliary equipment in accordance with local codes, standards, regulations, or laws applicable to safety.

Working Area



WARNING! Auxiliary equipment may have both manual and automatic modes of operation. As equipment can move suddenly and without warning, do not enter the work cell of this equipment during automatic operation, and do not enter the work envelope of this equipment during manual operation. If you do, serious injury can result.



WARNING! Make sure that power to the auxiliary equipment is turned OFF and locked out before you perform maintenance procedures on this equipment.

Qualification of Personnel

Make sure that all personnel have manufacturer-approved training applicable to the auxiliary equipment.

Personal Safety Equipment

Make sure that operators and maintenance personnel have all safety equipment applicable to the auxiliary equipment. Examples include safety glasses, protective headgear, safety shoes, etc.

Unauthorized Operation

Make sure that unauthorized personnel cannot gain access to the operation of the equipment.

Unauthorized Access



CAUTION! To prevent unauthorized access to the SIL Meter process, XMT1000 Flowmeter should be connected to PC only with a hardwired connection. Connection through internal networks or internet is not recommended

Environmental Compliance

Waste Electrical and Electronic Equipment (WEEE) Directive

Panametrics is an active participant in Europe's *Waste Electrical and Electronic Equipment (WEEE)* take-back initiative (Directive 2012/19/EU).

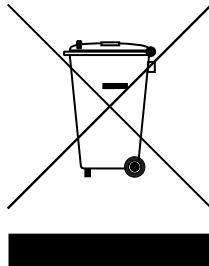

The equipment that you bought has required the extraction and use of natural resources for its production. It may contain hazardous substances that could impact health and the environment.

In order to avoid the dissemination of those substances in our environment and to diminish the pressure on the natural resources, we encourage you to use the appropriate take-back systems. Those systems will reuse or recycle most of the materials of your end life equipment in a sound way.

The crossed-out wheeled bin symbol invites you to use those systems.

If you need more information on the collection, reuse and recycling systems, please contact your local or regional waste administration.

Please visit www.bakerhughesds.com/health-safety-and-environment-hse for take-back instructions and more information about this initiative.

Chapter 1. Introduction

1.1 Overview of XMT1000 System1
 1.2 Theory of Operation 2
 1.3 SIL Application 3

Chapter 2. Installation

2.1 Introduction 5
 2.2 CE Marking Compliance 5
 2.3 Installation in Explosive Atmosphere 5
 2.4 Special Conditions for Safe Use 6
 2.5 Unpacking the XMT1000 7
 2.6 Site and Clearance Considerations 9
 2.6.1 Access to the Meter 9
 2.6.2 Vibration Exposure Considerations 9
 2.6.3 Sunlight Exposure 9
 2.6.4 Flowmeter Installation 10
 2.6.5 Remote Mounting 11
 2.6.6 Cable Lengths 11
 2.6.7 Transducer Cables 11
 2.7 Making the Electrical Connections 12
 2.7.1 Wiring the Analog Outputs 13
 2.7.2 Wiring the Digital Output 14
 2.7.3 Wiring the Modbus/Service Port 15
 2.7.4 Wiring HART or Foundation Fieldbus Connection (if applicable) 15
 2.7.5 Wiring Analog I/O Terminal Block (if applicable) 15
 2.7.6 Wiring the CH1 and CH2 Flying Lead 20
 2.7.7 Wiring the Line Power 20

Chapter 3. Programming

3.1 Introduction 23
 3.1.1 Secure Usage Advisory 23
 3.1.2 HMI Features 24
 3.1.3 Indicator Lights 24
 3.2 Passcodes 25
 3.2.1 Unlock from Keypad Lockout 25
 3.3 Measurement View Pages 25
 3.3.1 Measurement View 25
 3.3.2 Log-in and Primary Pages 30
 3.4 Main Program - System Settings 31
 3.4.1 Selecting Units 31
 3.4.2 Meter Settings 32
 3.5 Main Program - Inputs and Outputs 32
 3.5.1 Modbus Port Settings 32
 3.5.2 Standard Analog Output 33
 3.5.3 Standard Digital Output 36
 3.5.4 Option Comm Slot-1 (optional) 42
 3.5.5 Option I/O Slot-2 (Optional) 43
 3.5.6 Analog Output (SIL) - (Optional) 47
 3.6 Main Program - Programming (Clamp-on) 48
 3.6.1 Programming the Pipe 49
 3.6.2 Programming the Fluid 50
 3.6.3 Programming the Path Configuration 51
 3.6.4 Programming the Flow and Diagnostic Limits 52
 3.6.5 Programming Advanced Settings 53
 3.6.6 Channel X Programming 53
 3.6.7 Fluid Speed of Sound Calibration 56

3.7	Main Program – Programming (Wetted).....	58
3.7.1	Programming the Pipe	58
3.7.2	Programming the Fluid	59
3.7.3	Programming the Path Configuration	60
3.7.4	Programming the Flow and Diagnostic Limits	61
3.7.5	Programming Advanced Settings	61
3.8	Calibration.....	62
Chapter 4. Error Codes and Troubleshooting		
4.1	Introduction	65
4.2	Error Classification and Error Codes	65
4.3	Flow Errors (E-Errors).....	66
4.3.1	General Guidelines for Troubleshooting Flow Errors with Error codes	66
4.4	Fluid and Pipe Problems	69
4.4.1	Fluid Problems	69
4.4.2	Pipe Problems	69
4.5	Transducer Problems	70
4.5.1	Transducer Problems	70
4.6	System Errors (S-Errors)	70
4.7	Communication Errors (C-Errors).....	72
4.8	Transmitter Errors.....	72
4.9	Option I/O Errors	73
4.10	Diagnostics Data	75
Chapter 5. Maintenance and Service		
5.1	Spare Parts	77
5.2	Installing Replacement Parts	77
Appendix A. Specifications		
A.1	Operation and Performance.....	79
A.2	Electronics	80
A.3	Drawings	81
A.4	Wiring Diagram.....	82
Appendix B. Modbus map validation		
Appendix C. Error code bit-field representation		
Appendix D. HART Communication		
D.1	Wiring the XMT1000 to the HART Communicator	91
D.2	HART Write Mode Switch	91
D.3	DD File	92
D.3.1	HART Output Menu Map.....	92
D.3.2	HART Review Menu Map	93
D.4	Configurable Measurements	94
Appendix E. Wireless HART Communication		
E.1	Introduction	97
E.2	Installation and Configuration	97
E.2.1	XMT1000 to Masoneilan VECTOR Connection	97
E.2.2	XMT1000 configuration.....	98
E.2.3	Masoneilan VECTOR VI100 Adaptor configuration.....	98
E.2.4	Emerson Wireless Gateway Setup configuration.....	99
Appendix F. Foundation Fieldbus Communication		
F.1	Introduction	101

F.2	Installation	101
	F.2.1 Network Configuration	101
	F.2.2 Polarity	101
	F.2.3 Connection	102
	F.2.4 FISCO (Fieldbus Intrinsically Safe Concept)	102
	F.2.5 DD File	103
	F.2.6 Default Node Address	104
F.3	Specifications	105
	F.3.1 General	105
	F.3.2 Physical	105
	F.3.3 Communication	105
	F.3.4 User Layer	106
	F.3.5 Function Blocks	106
F.4	Resource Block	107
	F.4.1 FF Revision	107
	F.4.2 Password	108
	F.4.3 NAMUR NE107	109
F.5	XMIT Transducer Block	111
	F.5.1 Units	112
F.6	Composite Transducer Block	113
	F.6.1 Clearing the Totalizer	116
F.7	Configurable Measurements	117
F.8	Channel Transducer Block	119
F.9	Analog Input Block	122
F.10	PID Block	122
F.11	Error Handling	123
F.12	Simulation Mode	125
F.13	Fieldbus Troubleshooting Guide	126
F.14	DPI620 FF Modular Communicator	127

Appendix G. Menu Map

G.1	Primary Pages - SIL Type	129
G.2	Primary Pages - Non-SIL Type	129
G.3	Log-in Steps - SIL Type	130
G.4	Log-in Steps - Non-SIL Type	130
G.5	Meter Units and Settings	131
G.6	Error Log	131
G.7	Input/Output - Analog Output	132
G.8	Digital Output - Pulse Output	133
G.9	Digital Output - Frequency Output	134
G.10	Digital Output - Alarm	135
G.11	Communication Port	136
G.12	Input/Output - Option Comm (Slot 1)	136
	G.12.1 FF	136
	G.12.2 HART (PV Configuration)	137
G.13	Programming	137
	G.13.1 Composite Clamp-on (Pipe Configuration)	137
	G.13.2 Composite Wetted (Pipe Configuration)	138
	G.13.3 Composite Clamp-on and Wetted (Fluid)	138
	G.13.4 Composite - Path Configuration	139
	G.13.5 Composite (Limits Configuration)	140
	G.13.6 Composite (Advanced Configurations)	141
	G.13.7 Channels (Clamp-On)	142
	G.13.8 Channels (Wetted)	143
G.14	Calibration	144
G.15	Advanced	144
G.16	SIL Testing (Meter Type - SIL)	145

G.17 Factory145
 G.17.1 Serial Numbers145
 G.17.2 Factory Test146
 G.18 Input/Output146
 G.18.1 Option I/O (Slot 2)146
 G.18.2 Advanced Output SIL (Meter Type - SIL)148
 G.19 Display Measurement148
 G.19.1 One/Two Variable (Composite)148
 G.19.2 Channel 1149
 G.20 Measurement View149
 G.21 Forward Volume Total150
 G.22 Totalizer Display150
 G.23 Process Variable151
 G.24 Main Menu - Error/Warnings151
 G.25 Main Menu - Software Upgrades151

Chapter 1. Introduction

1.1 Overview of XMT1000 System

The XMT1000 is a one, two, or three channel liquid ultrasonic transmitter for either clamp-on or wetted ultrasonic flow measurement. The XMT1000 transmitter is used in conjunction with either the wetted PanaFlow HT, PanaFlow LZ, PanaFlow Z3 systems or the PanaFlow LC clamp-on ultrasonic systems.

This manual will serve as a guide to install the XMT1000 transmitter, selecting a proper location for mounting the transmitter (and overall flow meter), proper wiring, programming, error codes and troubleshooting, and maintenance and servicing procedures.



Figure 1: PanaFlow HT



Figure 2: PanaFlow LC



Figure 3: PanaFlow Z3



Figure 4: PanaFlow LZ

1.2 Theory of Operation

The XMT1000 uses a procedure called Transit-Time Flow Measurement. In this method, the flowmeter transmits ultrasonic pulses through a moving liquid. The pulses that travel in the same direction as the fluid flow (downstream) travel slightly faster than the pulses that travel against the fluid flow (upstream). The difference in transit times is then used to calculate flow velocity.

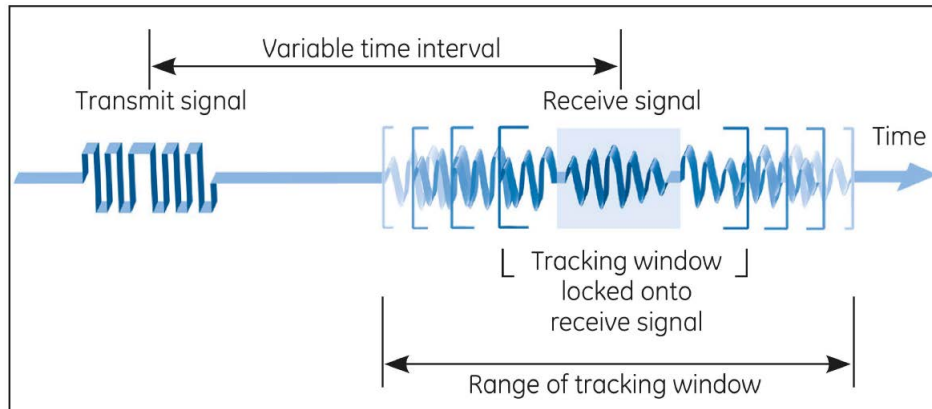

ATW ensures accuracy when fluid conditions change

Figure 5: Transit - Time Flow Measurement

1.3 SIL Application

The XMT1000 with appropriate flow meter selection can be a SIL2 ultrasonic flowmeter (sensor) with the capability of providing a SIL3 system in a redundant design configuration. The XMT1000 with either PanaFlow HT, LZ, Z3, or LC system is IEC61508 certified through a complete design validation from a third party organization. By achieving a third party certification, we have proven the required design rigor through the product safety lifecycle, and the implementation of functional safety management. This added design, manufacturing, and control rigor ensures that it is the optimal ultrasonic flowmeter for your safety or process control system.



CAUTION! Only qualified/trained personnel are allowed to change and validate safety parameters. Please refer to the XMT1000 safety manual for details on these parameters.

[no content intended for this page]

Chapter 2. Installation

2.1 Introduction

To ensure safe and reliable operation of the XMT1000, it must be installed in accordance with the established guidelines. Those guidelines, explained in detail in this chapter, include the following topics:

- Unpacking the XMT1000
- Selecting the location for the XMT1000 (local or remote)
- Installing the XMT1000 at the selected location
- Wiring the XMT1000



WARNING! The XMT1000 flow transmitter can measure the flow rate of many fluids, some of which are potentially hazardous. The importance of proper safety practices cannot be overemphasized.

Be sure to follow all applicable local safety codes and regulations for installing electrical equipment and working with hazardous fluids or flow conditions. Consult company safety personnel or local safety authorities to verify the safety of any procedure or practice.



Attention European Customers! To meet CE Marking requirements, all cables must be installed as described in *Section 2.2, "CE Marking Compliance"*.

2.2 CE Marking Compliance

For CE Marking compliance or installation in high noise areas, the XMT1000 flow transmitter must be wired in accordance with the instructions in this section.

IMPORTANT: CE Marking compliance is required for all units intended for use in EU countries.

The XMT1000 must be wired with the recommended cable, and all connections must be properly shielded and grounded. Grounding of the chassis must be within 10 ft (3 m) of the transmitter. Refer to *Table 1* below for the specific requirements.

Table 1: Wiring Requirements

Connection	Cable Type	Ground Termination
Transducer	Armored RG-62 a/U or equivalent	Grounded using a cable gland.
Input/Output	Armored 22 AWG shielded with armored material added to outside of jacket	Grounded using a cable gland.
Power	Armored 14 AWG 2 conductor	Grounded using a cable gland.

Note: If the XMT1000 is wired as described above, the unit will comply with the EMC and LVD Directives.

2.3 Installation in Explosive Atmosphere

When installing this apparatus, the following requirements must be met:

- The end user must ensure that any cable and cable entry devices used with the equipment are suitable for use at temperatures above 90°C.
- Wiring to or from this device, which enters or leaves the system enclosure, must utilize wiring methods suitable for class 1 Division 1 and/or class 1 zone 1 hazardous locations, as appropriate for the installation.
- Where meter head has potential for exposure to direct sunlight at high end of ambient temperature specifications, a sunshade should be installed.

- Connecting cables shall be mounted securely and protected from mechanical damage, pulling and twisting.
- Cable entries on the device are ¾" NPT, 6X in local mount configuration and 1x in remote mount configuration.
- For USA/CAN certification, process fluid shall be limited to 3705 psig. For ATEX/IECEx certification, process fluid shall be limited to 3750 psig.
- Cable glands of an approved flameproof design are required. These must be installed according to the manufacturer's instructions. Where the cable glands are provided by BH, the manufacturer's instructions, as supplied to BH, will be included in the documentation.
- The system is covered by the certificate numbers as shown on the labels on the following pages. The system temperature code is dependent upon the maximum process fluid temperature range.
- Unused entries must be sealed using a suitably certified threaded plug. Teflon tape or other sealing compounds are required when installing NPT threads.
- Modifications to the flameproof enclosure are not permitted.
- The apparatus should be de-energized before opening.
- Installation shall be in accordance with the installation instructions and the National Electrical Code® ANSI/NFPA 70, the Canadian Electrical Code C22.1, or IEC/EN 60079-14, as applicable.
- The product contains no exposed parts which produce surface temperature, infrared, electromagnetic ionizing, or non-electrical dangers.
- The product must not be subjected to mechanical or thermal stresses in excess of those permitted in the certification documentation and the instruction manual.
- The product cannot be repaired by the user; it must be replaced by an equivalent certified product. Repairs should only be carried out by the manufacturer or by an approved repairer.
- Only trained, competent personnel may install, operate, and maintain the equipment.
- The product is an electrical apparatus and must be installed in the hazardous area in accordance with the requirements of the Issued Certificate. The installation must be carried out in accordance with all the appropriate international, national and local standard codes and practices and site regulations for flameproof apparatus and in accordance with the instructions contained in the manual. Access to the circuitry must not be made during operation.
- For local mount configuration, the maximum process temperature shall be 95°C for meters with Hart or Foundation Fieldbus and IO Cards present. For meters with only Hart or Foundation Fieldbus and no IO Card present, maximum process temperature shall be 150°C. Maximum ambient temperature for local mount shall be 60°C for meters with Foundation Fieldbus and 65°C for all other configurations.
- Refer to this User Manual BH054C11 for detailed instructions for installation, operation, maintenance and service.

2.4 Special Conditions for Safe Use

- Contact the manufacturer if dimensional information of flameproof joints is needed.
- Field connections to the XMT1000 (e.g. ultrasonic transducers, accessories, or similar peripherals) shall be appropriately certified for the location and installed in accordance with wiring method requirements of the local electrical code as applicable.
- Follow the manufacturer's instructions to reduce the potential of an electrostatic charging hazard.
- It is end-user's responsibility to ensure that the ambient around the equipment does not exceed the permitted ambient of +60°C/+65°C.
- Only approved certified entry devices shall be used.
- The end user must ensure that any cable and cable entry devices used with the equipment are suitable for use at temperatures above 90°C.
- The end user is to ensure appropriate earthing upon installation.
- The temperature code rating of the PanaFlow™ PF10 Ultrasonic Liquid Flow Meter local mount and remote mount is dependent on the maximum process temperature.

2.5 Unpacking the XMT1000

Before removing the XMT1000 from its box, please inspect both the box and the instrument carefully. Each instrument manufactured by Panametrics is warranted to be free from defects in material and workmanship. Before discarding any of the packing materials, account for all components and documentation listed on the packing slip. The discarding of an important item along with the packing materials is all too common. If anything is missing or damaged, contact Panametrics Customer Care immediately for assistance.

The XMT1000 is supplied with both a serial number label and a certification label for identification of the instrument (see *Figure 6* and *Figure 7*). The system can be mounted either on an existing meter body (*local mounting*) or at another location via a connecting cable (*remote mounting*).

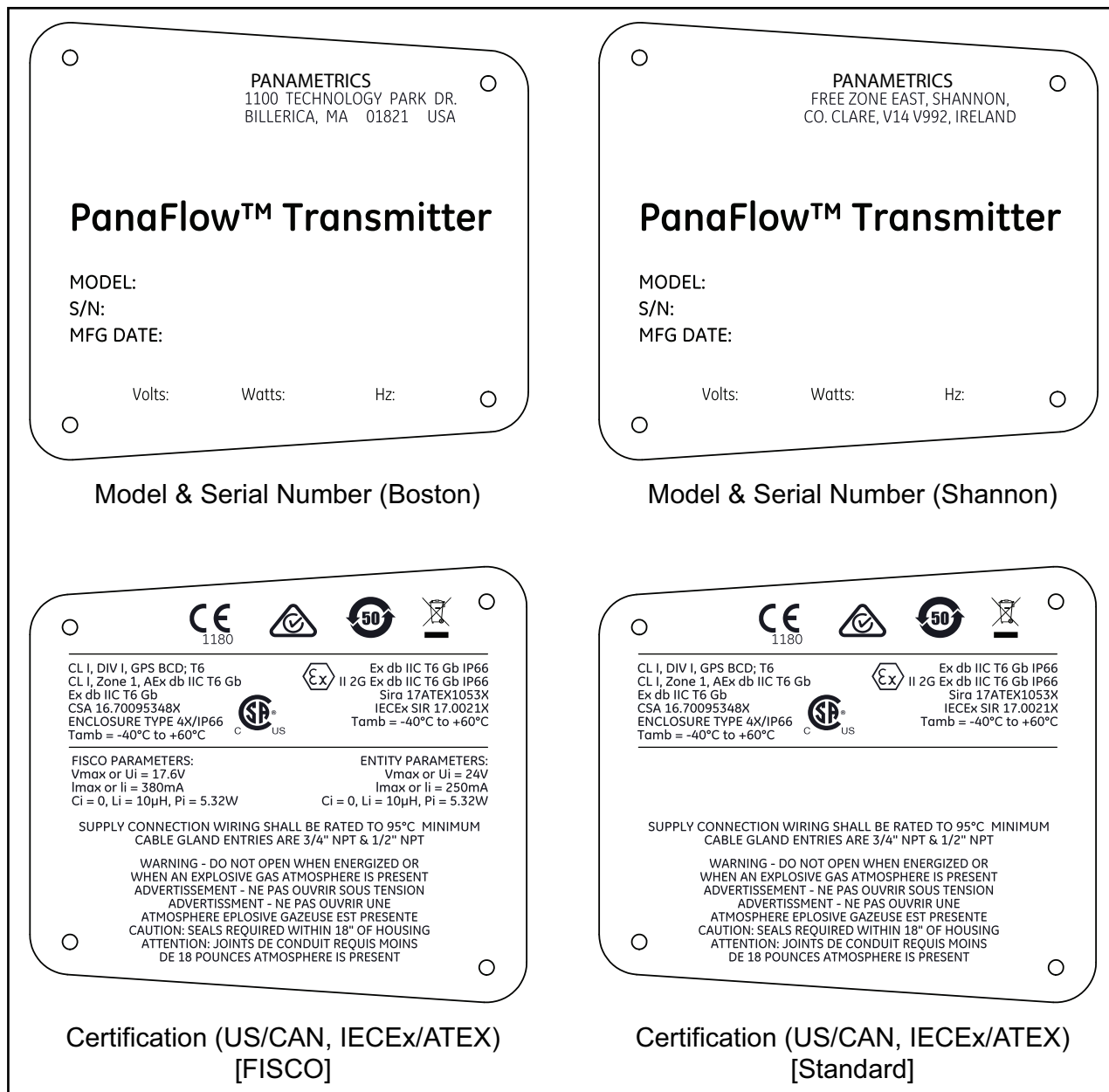

Figure 6: Typical XMT1000 Labels (Aluminum Enclosure)

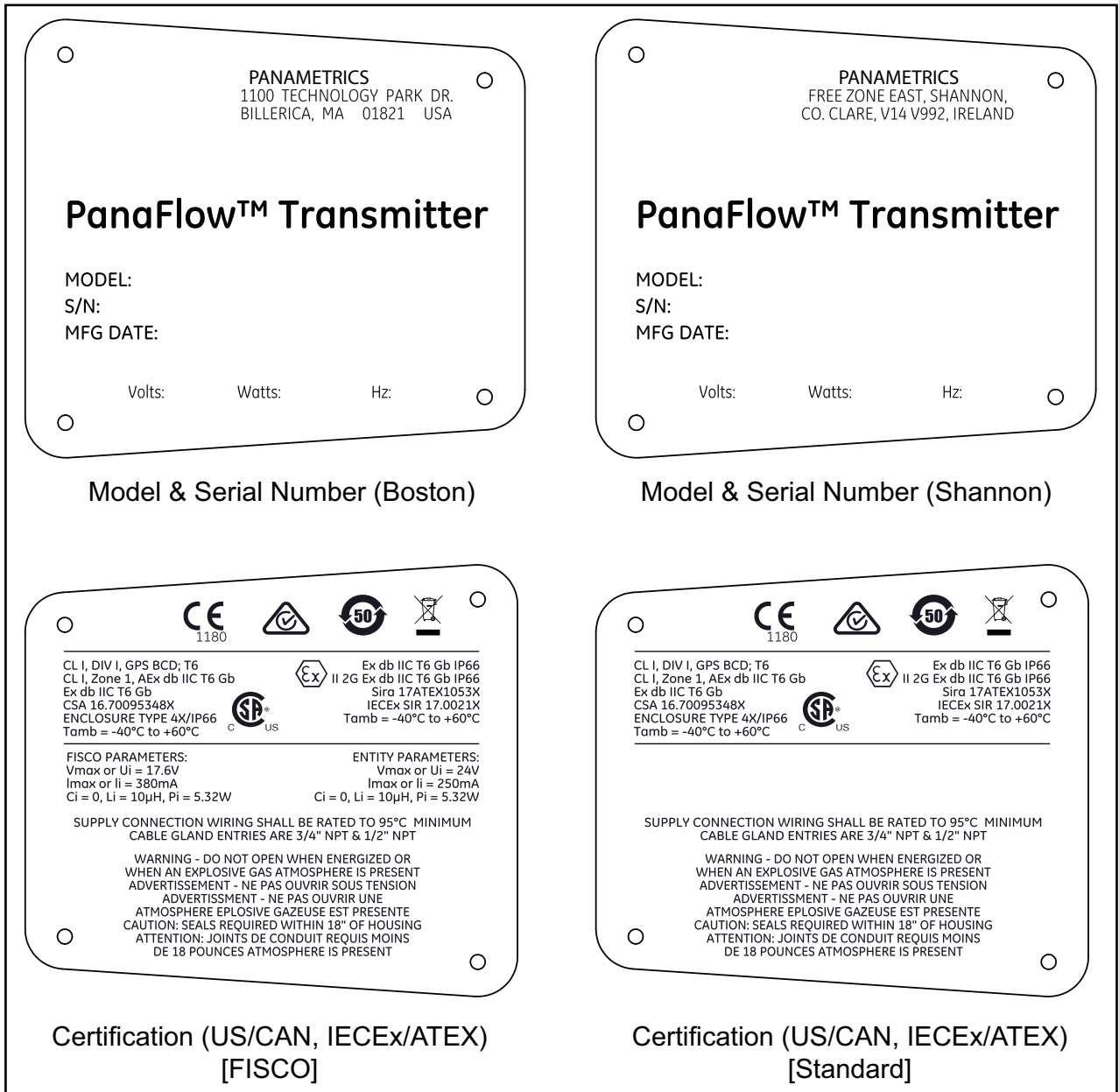

Figure 7: Typical XMT1000 Labels (Stainless Steel Enclosure)

2.6 Site and Clearance Considerations

2.6.1 Access to the Meter

Because the relative location of the flowcell and the XMT1000 transmitter is important, use the guidelines in this section to plan the XMT1000 installation.

For flowcell clearance recommendations, consult the manual for your specific flow meter system or contact Panametrics for assistance. Access to the XMT1000 flow transmitter should be uninhibited, as defined by the minimum clearance distances around the enclosure specified in *Figure 8 on page 9*.

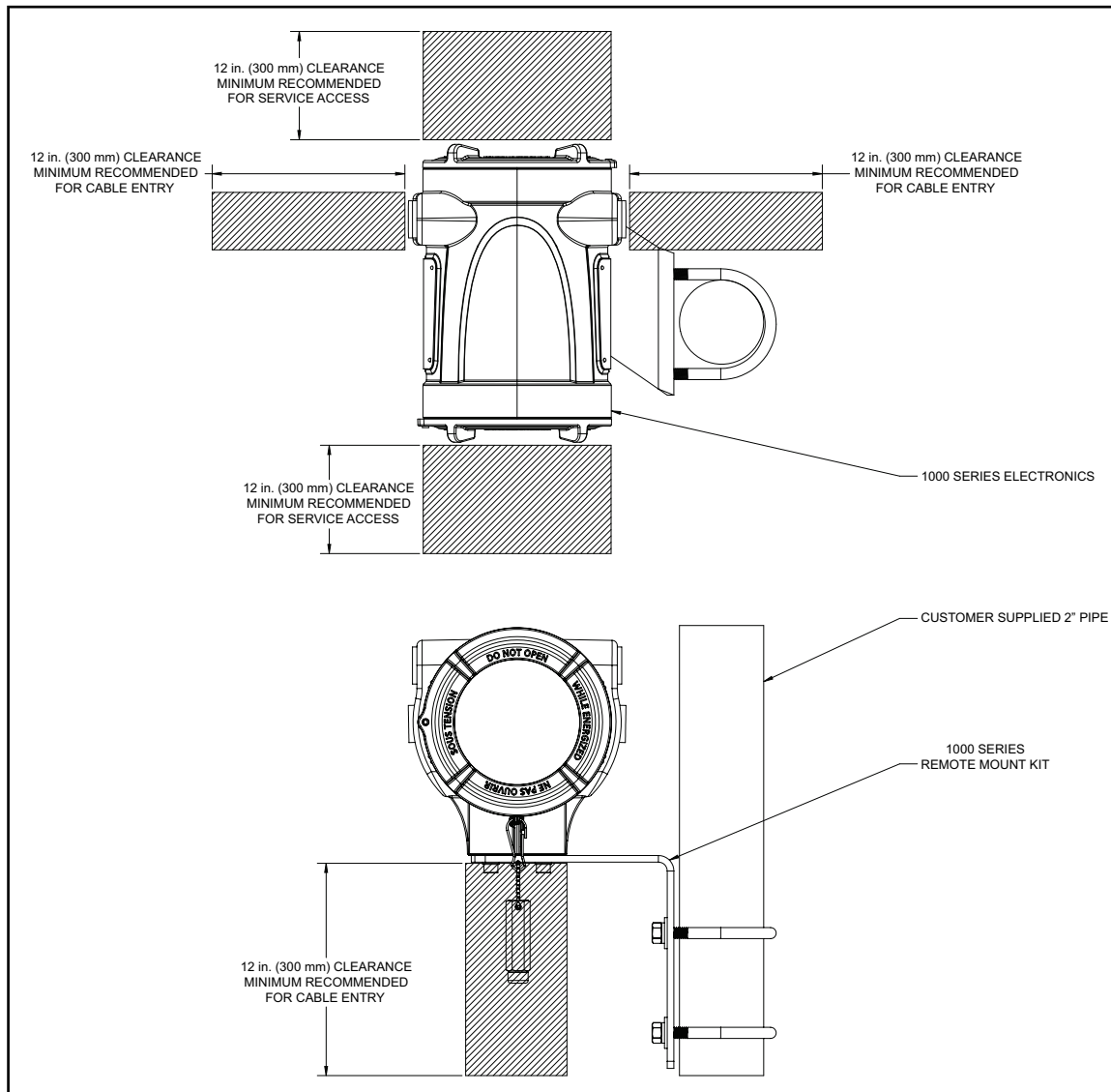

Figure 8: XMT1000 Enclosure Clearances (ref. dwg. 712-2164)

2.6.2 Vibration Exposure Considerations

Whenever possible, install the XMT1000 flow transmitter in a location isolated from vibrations. Avoid installing it near equipment that generates low-frequency, high-energy random vibrations.

2.6.3 Sunlight Exposure

The installer should consider and limit exposure of the XMT1000 flow transmitter to direct sunlight. Sunshades should be utilized in extreme environments.

2.6.4 Flowmeter Installation

The XMT1000 accuracy is affected by the flowcell location in the process piping and on the orientation of the transducers. Thus, in addition to accessibility for maintenance, adhere to the following installation guidelines:

- Locate the flowcell so that there are at least 10 pipe diameters of straight, undisturbed flow upstream and 5 pipe diameters of straight, undisturbed flow downstream from the measurement point (see *Figure 9* below). Undisturbed flow means avoiding sources of turbulence in the fluid (e.g., valves, flanges, expansions, elbows, etc.), avoiding swirl, and avoiding cavitation.

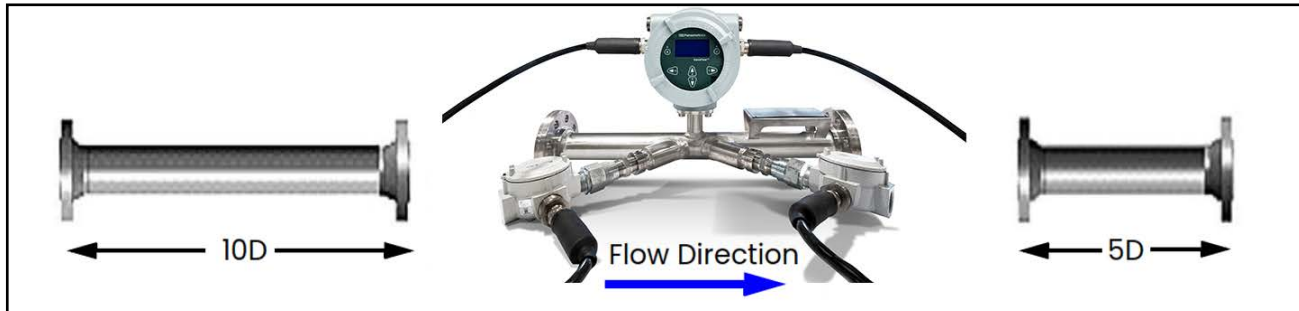

Figure 9: Minimum Straight Run Pipe Requirements

- Locate the transducers on a common axial plane along the pipe. Also, locate them on the side of the pipe instead of on the top or the bottom, because the top of the pipe tends to accumulate gas and the bottom tends to accumulate sediment. Either condition will cause unwanted attenuation of the ultrasonic signals. There is no similar restriction with vertical pipes, as long as the fluid flow is upward to prevent free falling of the fluid or a less than full pipe (see *Figure 10* below).

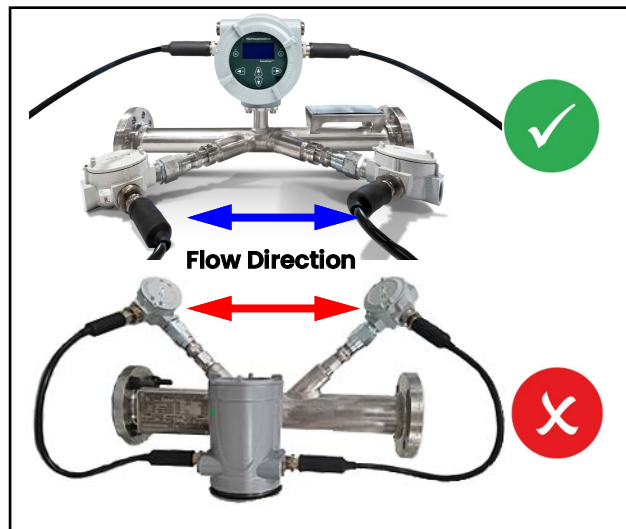

Figure 10: Good and Bad Flowcell/Transducer orientations in horizontal pipes



CAUTION! Do not place thermal insulation on or around the transducers, the junction boxes, or the meter electronics. The transducer and junction box act as a heat sink that protects the transducer from high and low temperatures.

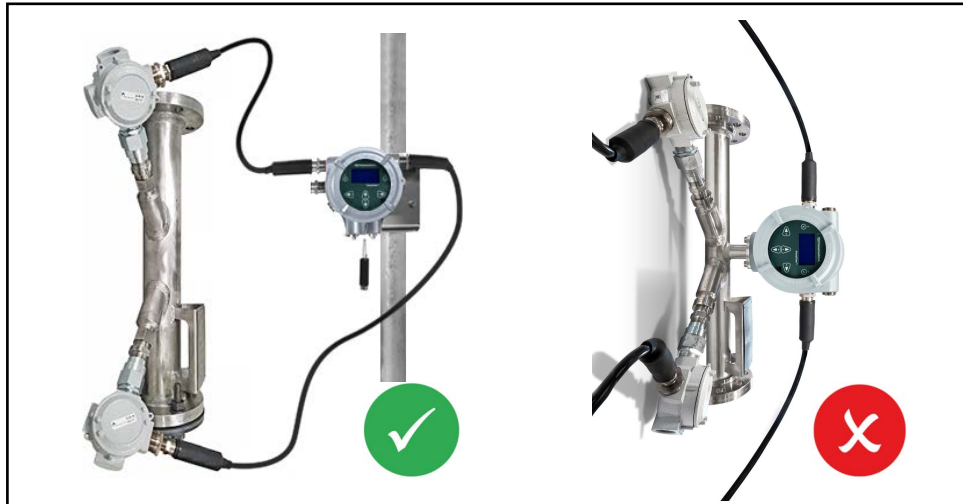

Figure 11: Remote mounting of the XMT1000 meter is always required with vertical pipes



CAUTION! Local mounting of the XMT1000 meter is not permitted for vertical pipes.



CAUTION! Remote mounting of the XMT1000 meter is always required with vertical pipes. For vertical pipes, the fluid flow is / must be upwards as the measurement method requires the pipe to be full.

2.6.5 Remote Mounting

The standard XMT1000 enclosure is a powder-coated, aluminum, IP67 explosion-proof enclosure. Typically, the enclosure is mounted as close as possible to the transducers. When choosing a site for a remote-mount installation, which is recommended for process temperatures exceeding 150°C, make sure the location permits easy access to the enclosure for programming, maintenance and service.



Attention European Customers! For compliance with the European Union's Low Voltage Directive, this unit requires an external power disconnect device such as a switch or circuit breaker. The disconnect device must be marked as such, clearly visible, directly accessible, and located within 1.8 m (6 ft) of the unit.

2.6.6 Cable Lengths

Locate the XMT1000 as close as possible to the transducers. The maximum distance from the transducers for remote mounting of the XMT1000 is 1000 ft (300 m) using coaxial cable for the PanaFlow HT, PanaFlow LZ, and PanaFlow LC systems. For the PanaFlow Z3, the maximum distance is 100 feet. If longer distances are required, consult the factory for assistance.

2.6.7 Transducer Cables

When installing the transducer cables, always observe established standard practices for the installation of electrical cables. Do not route transducer cables alongside high amperage AC power lines or any other cables that could cause electrical interference. Also, protect the transducer cables and connections from the weather and corrosive atmospheres, and be sure to follow the manufacturer's installation guidelines if cable glands are provided.

2.7 Making the Electrical Connections

This section contains instructions for making all the necessary electrical connections for the XMT1000 flow transmitter. Refer to *Figure 12 on page 13* for a complete wiring diagram.

Note: Both flying lead and MCX transducer connectors are shown in the figure for completeness. Only the type of connector appropriate for each meter ordered will be installed on the PCB. Typically, flying leads is used for transducer connections with the PanaFlow HT, PanaFlow LZ, and PanaFlow LC systems while MCX connectors are used with the PanaFlow Z3.



WARNING! Always disconnect the line power from the XMT1000 before removing either the front cover or the rear cover. This is especially important in a hazardous environment.



Attention European Customers! To meet CE Marking requirements, all cables must be installed as described in *“CE Marking Compliance” on page 5*.

Prepare the XMT1000 for wiring by completing the following steps:

- To access the wiring terminals, complete the following steps:
 1. Disconnect any previously wired power line from the unit.
 2. Loosen the set screw on the wiring cover.
 3. Place a rod or long screwdriver across the cover in the slots provided, and rotate the cover counterclockwise until it comes free from the enclosure.
 4. Install any required cable glands in the appropriate conduit holes on the opposite side of the enclosure.
 5. Note the labels inside the rear cover to assist in wiring the power and option connections.

Wiring any option set requires completion of the following general steps:

1. Disconnect the main power from the unit and remove the wiring cover.
2. Install a cable gland in the chosen conduit hole on the side of the electronics enclosure and feed a standard 26-12 AWG twisted-pair cable through this conduit hole.
3. Locate the *Standard I/O* or *Analog I/O* options terminal block and wire the option as indicated on the label inside the wiring cover. Secure the cable gland.
4. If wiring of the unit has been completed, reinstall the wiring cover on the enclosure and tighten the set screw.



WARNING! Proper grounding of the XMT1000 enclosure via the external grounding screw on the enclosure (see *Figure 12 on page 13*) is required to prevent the possibility of electric shock. All ground screws should be hand tightened only, to a maximum allowable torque of 2.5 N-m (22 in-lb).

For specific instructions on wiring a particular output configuration, proceed to the appropriate sub-section.

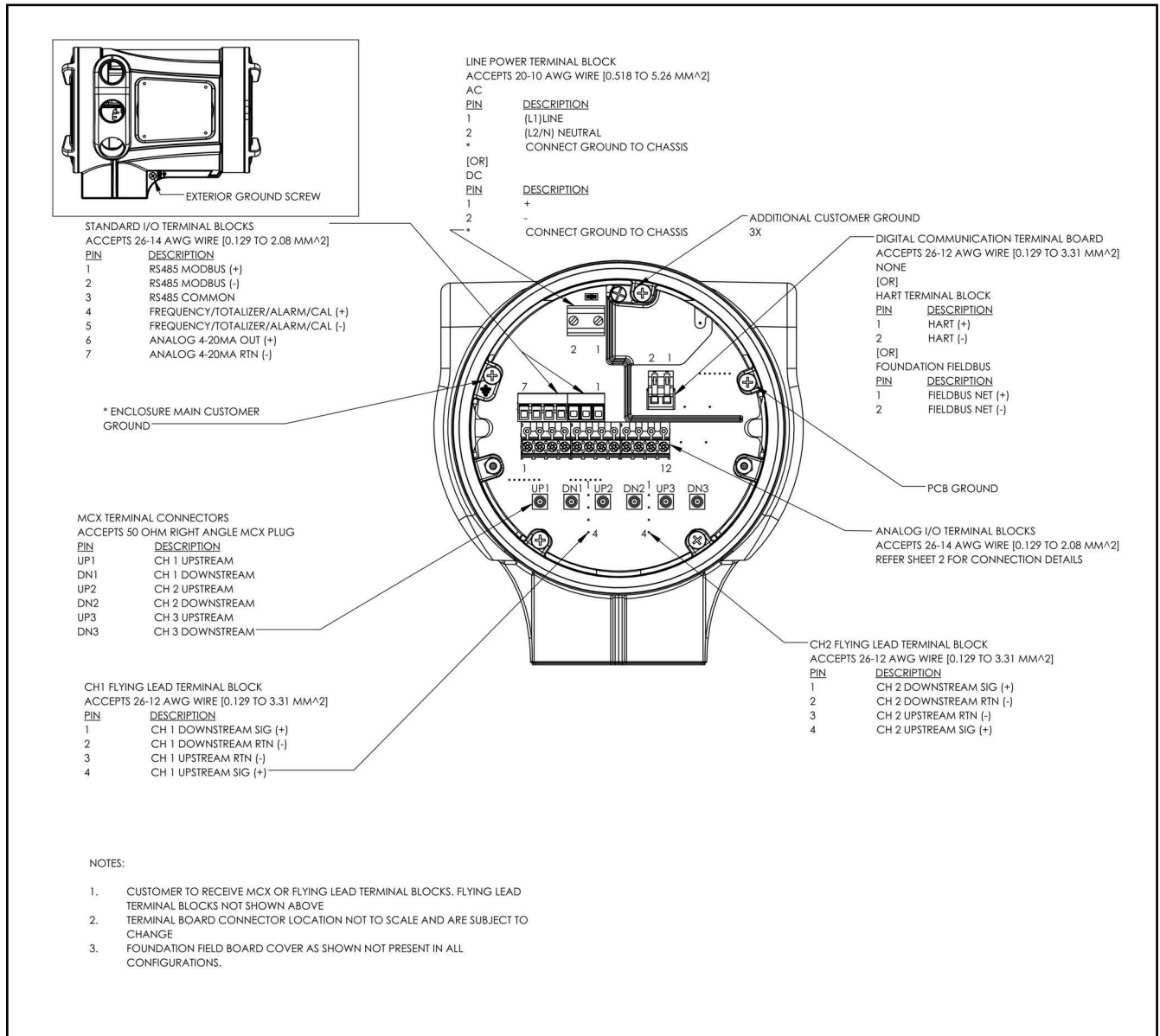

Figure 12: XMT1000 Terminal Board Wiring Diagram

2.7.1 Wiring the Analog Outputs

The standard configuration of the XMT1000 flow transmitter includes one isolated 4–20 mA analog output. Connections to this output may be made with standard twisted-pair wiring, but the current loop impedance for this circuit must not exceed 600 ohms. Two additional analog outputs are available as an option.

To wire the analog outputs, complete the following steps:

1. Disconnect the main power to the unit and remove the wiring cover.
2. Install the required cable gland in the chosen conduit hole on the side of the electronics enclosure.
3. Refer to *Figure 12* on page 13 for the location of the terminal block and wire the analog output as shown. Secure the cable gland.



Attention European Customers!To meet CE Marking requirements, all cables must be installed as described in *“CE Marking Compliance” on page 5.*

IMPORTANT: Analog output A is an active signal. Do not supply power to this circuit, as the circuit is powered by the flow meter.

4. If wiring of the unit has been completed, reinstall the wiring cover on the enclosure and tighten the set screw.



WARNING! Make sure all covers, with their o-ring seals, are installed and the set screws tightened before applying power in a hazardous environment.

Note: Prior to use, the analog output must be set up and calibrated. Proceed to the next section to continue the initial wiring of the unit.

Note: See Appendix A, Specifications, for the load and voltage requirements.

2.7.2 Wiring the Digital Output

The standard XMT1000 flow transmitter configuration includes one isolated digital output, which can be used as a totalizer (pulse) output, a frequency output, an alarm relay, or a calibration port. Wiring this output requires completion of the following general steps:

1. Disconnect the main power to the unit and remove the wiring cover.
2. Install the required cable gland in the chosen conduit hole on the side of the electronics enclosure.
3. Refer to *Figure 12 on page 13* for the location of the terminal block and wire the digital output as shown. Secure the cable gland. Refer to *Chapter A, Specifications*, for the load and voltage requirements.



Attention European Customers!To meet CE Marking requirements, all cables must be installed as described in *“CE Marking Compliance” on page 5.*

4. If wiring of the unit has been completed, reinstall the wiring cover on the enclosure and tighten the set screw.



WARNING! Make sure all covers, with their o-ring seals, are installed and the set screws tightened before applying power in a hazardous environment.

2.7.2.1 Wiring as a Calibration Port

Performing a calibration of the meter requires entering an Admin-level password.

2.7.3 Wiring the Modbus/Service Port

The XMT1000 flow transmitter is equipped with a Modbus communication port for either a connection to PanaView™ Plus (PC software) or to a separate control system. The port is an RS485 interface.

IMPORTANT: The maximum cable length for an RS485 connection is 4000 ft (1200 m).

To wire to this RS485 serial port, refer to *Figure 12 on page 13* and complete the following steps:

1. Disconnect the main power to the unit and remove the rear cover.
2. Install the required cable gland in the chosen conduit hole on the side of the electronics enclosure.
3. Feed one end of the cable through the conduit hole, and wire it to the terminal block.
4. If wiring of the unit has been completed, reinstall the wiring cover on the enclosure and tighten the set screw.

Note: Prior to use, the serial port must be programmed.



WARNING! Make sure all covers, with their o-ring seals, are installed and the set screws tightened before applying power in a hazardous environment.

2.7.4 Wiring HART or Foundation Fieldbus Connection (if applicable)

The XMT1000 flow transmitters has the option for an additional 4–20mA/HART output or a Foundation Fieldbus output on terminal block #1 (TB1) per *Figure 12 on page 13*. In the HART system an active signal is used, whereas FF corresponds to a passive signal. Connections to this output may be made with standard twisted-pair wiring, but the current loop impedance for this circuit must not exceed 600 ohms.

To wire the HART or Foundation Fieldbus outputs complete the following steps:

1. Disconnect the main power to the unit and remove the wiring cover.
2. Install the required cable gland in the chosen conduit hole on the side of the electronics enclosure.
3. Refer to *Figure 12 on page 13* for the location of the terminal block and wire the HART or Foundation Fieldbus output as shown. Secure the cable gland.



Attention European Customers! To meet CE Marking requirements, all cables must be installed as described in “CE Marking Compliance” on page 5.

4. If wiring of the unit has been completed, reinstall the wiring cover on the enclosure and tighten the set screw.

2.7.5 Wiring Analog I/O Terminal Block (if applicable)

The XMT1000 flow transmitters has the option for additional analog outputs, analog inputs, and RTD inputs on terminal block #2 (TB2) per *Figure 12 on page 13*. Connections to this output may be made with standard twisted-pair wiring.

To wire the HART or Foundation Fieldbus outputs, complete the following steps:

1. Disconnect the main power to the unit and remove the wiring cover.
2. Install the required cable gland in the chosen conduit hole on the side of the electronics enclosure.
3. Refer to *Figure 12 on page 13* for the location of the terminal block and wire the additional I/O output as shown along with the table below.
4. Secure the cable gland.

Table 2: Wiring Additional I/O Terminal Block

Option Code	Description	Pins (Terminal Block #2)											
		1	2	3	4	5	6	7	8	9	10	11	12
-1	Two analog outputs, two analog inputs	AO 1 High	AO 1 Low	AO 2 High	AO 2 Low	CH1 24V Out	All High	All RTN	All RTN	CH2 24V Out	AI2 High	AI2 RTN	AI2 RTN
-2	Two analog outputs, one analog input, one RTD-PT100 3-wire	AO 1 High	AO 1 Low	AO 2 High	AO 2 Low	CH1 24V Out	All High	All RTN	All RTN	NC	RTD2 S+	RTD2 S-	RTD2 RTN
-3	Two analog outputs, two RTD-PT100 3-wire	AO 1 High	AO 1 Low	AO 2 High	AO 2 Low	NC	RTD1 S+	RTD1 S-	RTD1 RTN	NC	RTD2 S+	RTD2 S-	RTD2 RTN
-4	Two analog outputs, one analog input, one RTD-PT100 4-wire	AO 1 High	AO 1 Low	AO 2 High	AO 2 Low	CH1 24V Out	All High	All RTN	All RTN	RTD2 C	RTD2 S+	RTD2 S-	RTD2 RTN
-5	Two analog outputs, two RTD-PT100 4-wire	AO 1 High	AO 1 Low	AO 2 High	AO 2 Low	RTD1 C	RTD1 S+	RTD1 S-	RTD1 RTN	RTD2 C	RTD2 S+	RTD2 S-	RTD2 RTN
-6	Two analog outputs, one analog input, one RTD-PT1000 3-wire	AO 1 High	AO 1 Low	AO 2 High	AO 2 Low	CH1 24V Out	All High	All RTN	All RTN	NC	RTD2 S+	RTD2 S-	RTD2 RTN
-7	Two analog outputs, two RTD-PT1000 3-wire	AO 1 High	AO 1 Low	AO 2 High	AO 2 Low	NC	RTD1 S+	RTD1 S-	RTD1 RTN	NC	RTD2 S+	RTD2 S-	RTD2 RTN
-8	Two analog outputs, one analog input, one RTD-PT1000 4-wire	AO 1 High	AO 1 Low	AO 2 High	AO 2 Low	CH1 24V Out	All High	All RTN	All RTN	RTD2 C	RTD2 S+	RTD2 S-	RTD2 RTN
-9	Two analog outputs, two RTD-PT1000 4-wire	AO 1 High	AO 1 Low	AO 2 High	AO 2 Low	RTD1 C	RTD1 S+	RTD1 S-	RTD1 RTN	RTD2 C	RTD2 S+	RTD2 S-	RTD2 RTN
-10	Two SIL rated analog outputs	SIL1 High	SIL1 Low										



Attention European Customers! To meet CE Marking requirements, all cables must be installed as described in *“CE Marking Compliance” on page 5.*

5. If wiring of the unit has been completed, reinstall the wiring cover on the enclosure and tighten the set screw.

2.7.5.1 Wiring directions for passive/active inputs

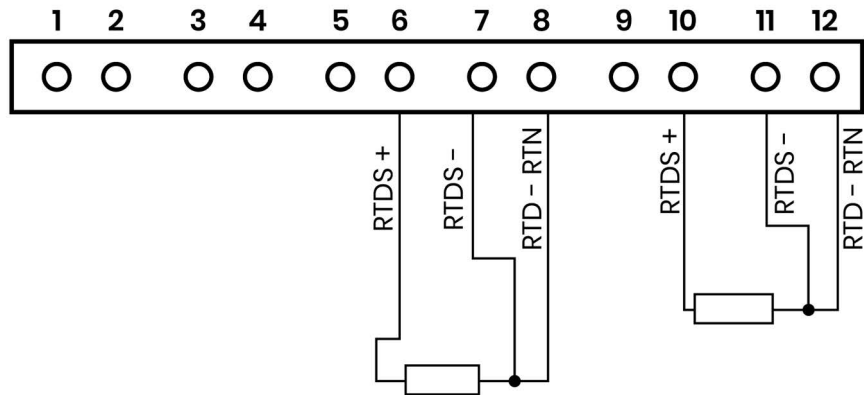

Figure 13: 3-wire RTD

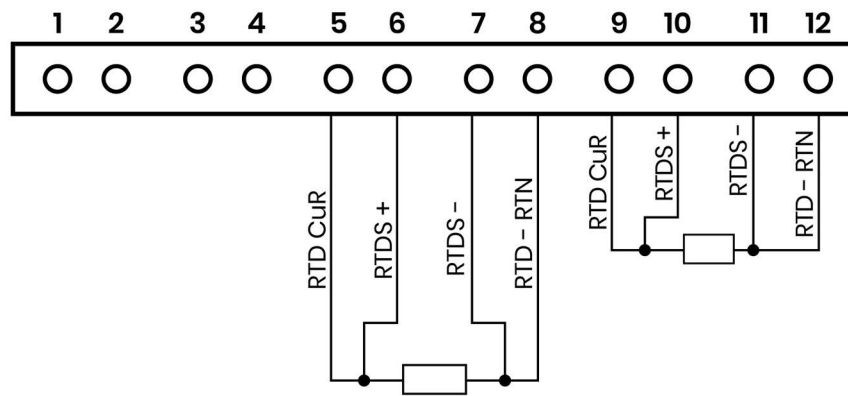

Figure 14: 4-wire RTD

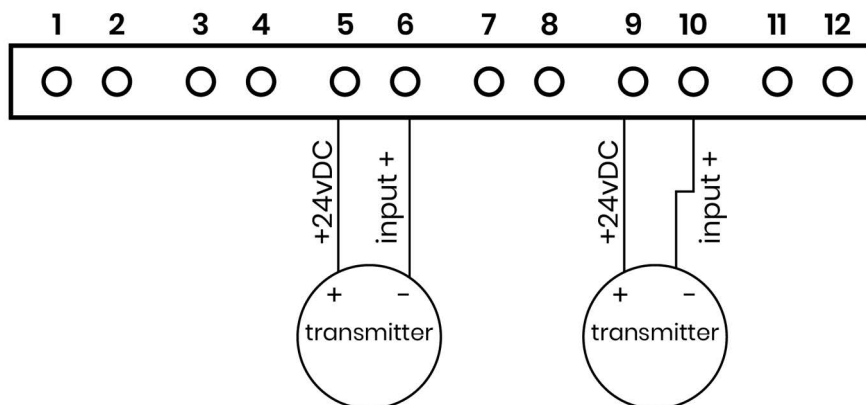

Figure 15: Analog input with internal power supply

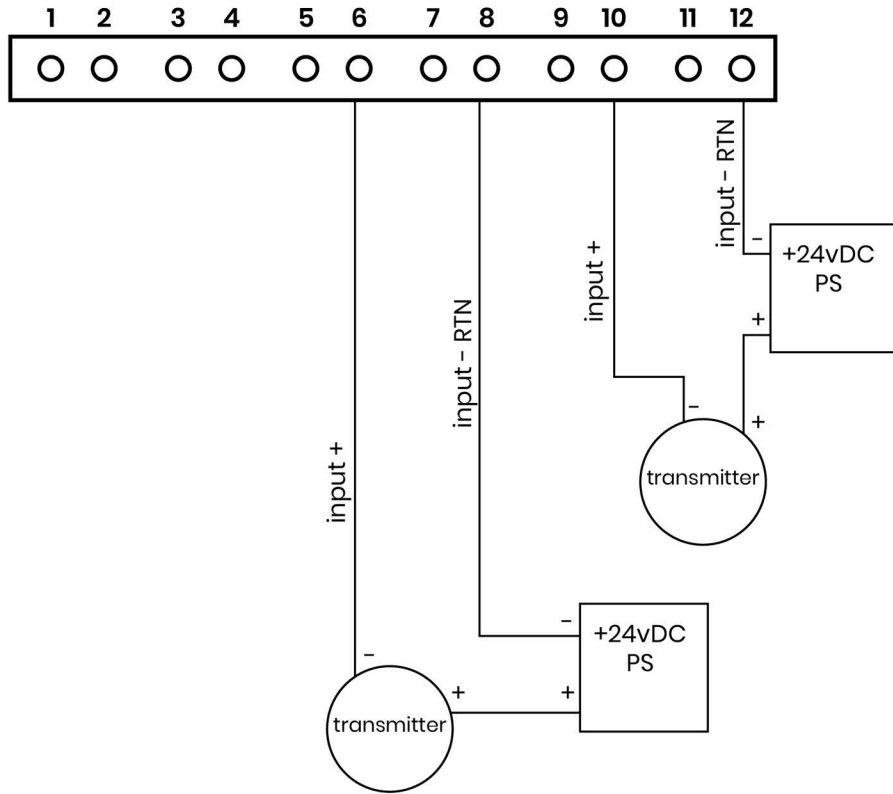

Figure 16: Analog input with external power supply

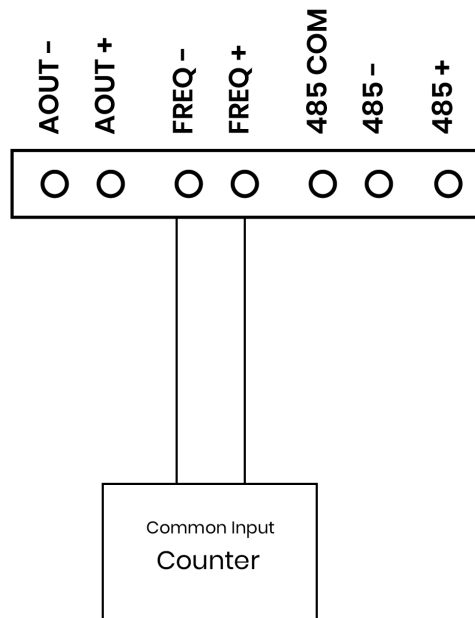

Figure 17: Frequency/Totalizer output

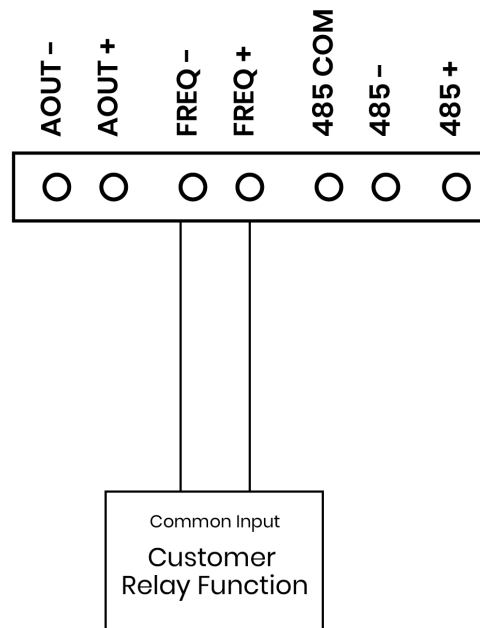

Figure 18: Wiring of Alarm relay output

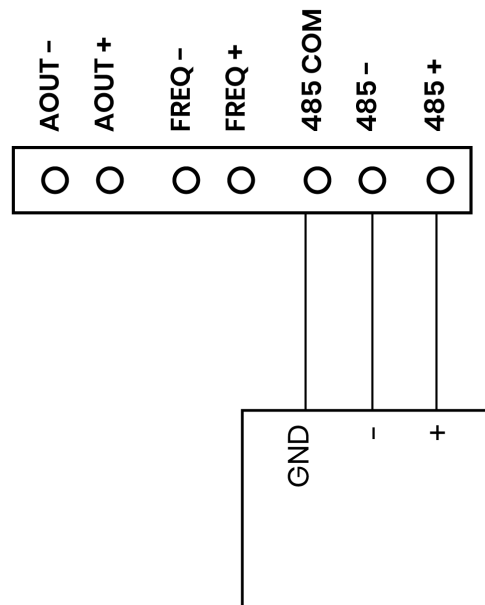

Figure 19: RS-485

2.7.6 Wiring the CH1 and CH2 Flying Lead

Refer to Figure 12 on page 13 and Section 2.7.1, "Wiring the Analog Outputs" to locate the Channel 1 and Channel 2 flying lead terminal blocks.

To wire the CH 1 flying lead to the terminal block 5, refer to Figure 20 and complete the following steps:

1. Disconnect the main power to the unit and remove the rear cover.
 2. Install the required cable gland in the chosen conduit hole on the side of the electronics enclosure.
 3. Feed one end of the CH 1 downstream RG62 cable red wire through the conduit hole of DN terminal, and wire it to the terminal block.
 4. Feed one end of the CH 1 downstream RG62 cable black wire through the conduit hole of RTN terminal below the DN terminal, and wire it to the terminal block.
 5. Feed one end of the CH 1 upstream RG62 cable red wire through the conduit hole of UP terminal, and wire it to the terminal block.
 6. Feed one end of the CH 1 upstream RG62 cable black wire through the conduit hole of RTN terminal above the UP terminal, and wire it to the terminal block.
 7. If wiring of the unit has been completed, reinstall the wiring cover on the enclosure and tighten the set screw.
 8. To wire the CH 2 flying lead to the terminal block 6, repeat the above steps.
- [no content intended for this page]

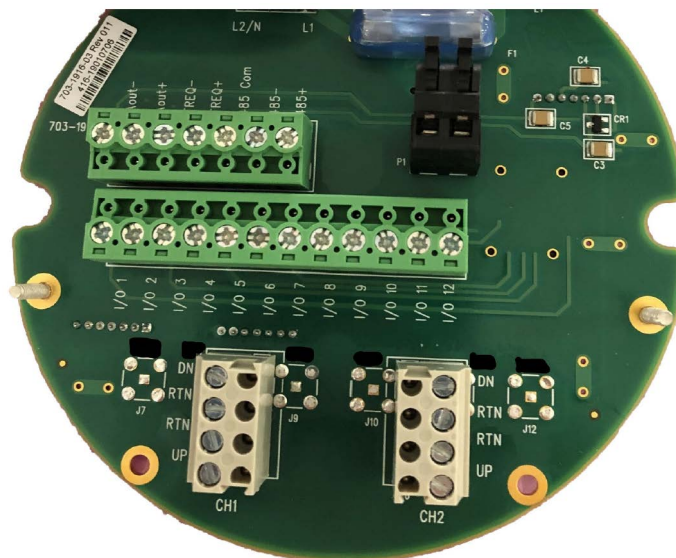

Figure 20: CH1 and CH2 Flying Lead Wiring

2.7.7 Wiring the Line Power

The XMT1000 may be ordered for operation with power inputs of either 100-240 VAC or 12-28 VDC. The label on the side of the enclosure lists the meter's required line voltage and power rating. Be sure to connect the meter to the specified line voltage only.



Attention European Customers! For compliance with the European Union's Low Voltage Directive, this unit requires an external power disconnect device such as a switch or circuit breaker. The disconnect device must be marked as such, clearly visible, directly accessible, and located within 1.8 m (6 ft) of the unit.



CAUTION! The DC version is intended to be supplied by Class 2, SELV or equivalent power source.

Refer to *Figure 12 on page 13* to locate the terminal blocks and connect the line power as follows:

1. Prepare the line power leads by trimming the line and neutral AC power leads (or the positive and negative DC power leads) to a length 0.5 in. (1 cm) shorter than the ground lead. This ensures that the ground lead is the last to detach if the power cable is forcibly disconnected from the meter.
2. Install a suitable cable gland in the conduit hole. If possible, avoid using the other conduit holes for this purpose, to minimize any interference in the circuitry from the AC power line.



Attention European Customers! To meet CE Marking requirements, all cables must be installed as described in *“CE Marking Compliance” on page 5*.

3. Route the cable through the conduit hole and connect the line power leads to the power terminal, using the pin number assignments shown in *Figure 12 on page 13*.

IMPORTANT: The ground wire must be connected to the system chassis.

4. Leaving a bit of slack, secure the power line with the cable clamp.
5. If wiring of the unit has been completed, reinstall the wiring cover on the enclosure and tighten the set screw.



WARNING! Make sure all covers, with their o-ring seals, are installed and the set screws tightened before applying power in a hazardous environment.



CAUTION! The transducers must be properly wired before applying power to the meter.

[no content intended for this page]

Chapter 3. Programming

3.1 Introduction

This chapter has instructions for programming various features of the *PanaFlow™ XMT1000* flow transmitter. In this chapter, we will list all available options. The user can then change the *User Preferences* and *Inputs/Outputs* settings, *Programming* for flow measurements and *Calibration* to meet their needs.

3.1.1 Secure Usage Advisory

IMPORTANT: Only qualified and trained personnel are allowed to change and validate safety parameters. Please refer to the XMT1000 safety manual for details on these parameters. Not all users will have access to all of the menus. Some menus are restricted to only those users with the proper passcode.



CAUTION! XMT1000 Flowmeter should be connected to PC only with a hardwired connection. Connection through internal networks or internet is not recommended.



IMPORTANT: It is the full responsibility of the end user to observe the cyber security precautions for this product. The authorized user must maintain and safeguard the user level passwords that are required to access program parameters in the instrument via the keypad, PanaView™ Plus software, HART or Modbus. The user must safeguard program site files that are maintained outside the instrument and loaded via digital communications. The user must connect to the instrument via a direct wired connection. Any connection to the Internet is not recommended.



IMPORTANT: It is required that the connected PC is always scanned with an updated anti-virus program.

It is recommended for users to regularly check firmware upgrades and communication from Panametrics.

3.1.2 HMI Features



Figure 21: XMT1000 HMI

The six keys on the magnetic keypad are used to program the XMT1000:

Key Symbol	Key Name	Functions
✘	Escape Key	To cancel a numeric entry change, exit a menu or as Back key
✔	Enter Key	To accept a numeric entry or select a menu option
◀	Left Arrow Key	To navigate among menu choices, pages or set cursor position
▶	Right Arrow Key	To navigate among menu choices, pages or set cursor position
▲	Up Arrow Key	To navigate among menu choices, pages or increase/decrease numeric entries
▼	Down Arrow Key	To navigate among menu choices, pages or increase/decrease numeric entries

3.1.3 Indicator Lights

- The blue light on the top right above the display is the **Power Indicator** that is normally lit when the instrument is powered.
- The red light on the top left above the display is the **Error Indicator**. The *Error Indicator* light blinks if an instrument error is detected. A short error message will be displayed in the lower left-hand corner of the *Measurement View*. If the instrument is operating without error, red light is turned OFF.

3.2 Passcodes

IMPORTANT: Not all users will have access to all of the menus. Some menus are restricted to only those users with the proper passcodes.

The default passcodes for the XMT1000 flow transmitter are:

- Keypad Lockout Password, default (fixed) = 102719 [this password cannot be changed]
- Operator Password, default (changeable) = 111111
- Software Upgrade Password, System Generated specific for the System Serial Number [this password cannot be changed].

IMPORTANT: Panametrics recommends changing all default (changeable) passwords after commissioning the meter.

3.2.1 Unlock from Keypad Lockout

After power up, if the meter's *Measurement View* (Refer *Figure 22*) shows a lock icon on the top right of the display, use the following steps to unlock the meter from keypad lockout mode.

- Press ESC-ENT-ESC [\times \checkmark \times] followed by either "Operator" password or the "Keypad Lockout" password. The lock icon on the top right of the display will show an open lock indicating the meter keypad is unlocked.

3.3 Measurement View Pages

3.3.1 Measurement View

On power up, the XMT1000 meter shows the following screens:

- Panametrics Logo screen
- Meter Initialization screens
- Power-on self-tests and results
- Finally, the *Measurement View* (Refer *Figure 22*)

This screen (Refer *Figure 22*) will be referred to as "*Measurement View*" throughout this chapter. User can choose the measurement to be displayed in this view from a list of options. The Error indicator at the bottom left of the display will be blank if the meter has no error.

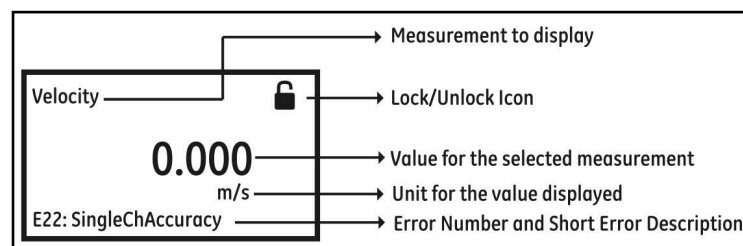

Figure 22: Measurement View

3.3.1.1 Changing Display Format

To change Display Format, do the following steps and refer *Figure 23*.

1. Press [▶] until the lock icon on the meter's *Measurement View* display is highlighted, and press [ENTER].
2. In the *Main Menu* select [Display Format], then press [ENTER].
3. Select [One Variable] or [Two Variable] or [Totalizer] format to suit your needs.

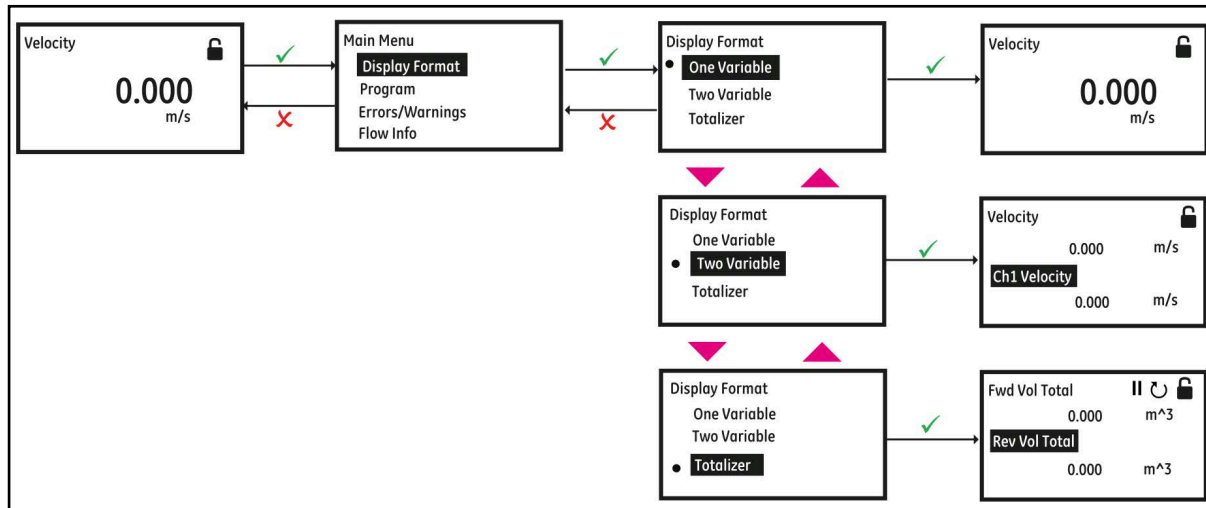

Figure 23: Changing Display Format

3.3.1.2 Selecting a Composite Measurement to Display

To select a composite measurement to display on the *Measurement View*, do the following steps and refer *Figure 24*.

1. Press [▶] until the Measurement name on the meter's Measurement View display is highlighted, and press [ENTER].
2. In the *Display Measurement* select [**Composite**], then press [ENTER].
3. Then, select the measurement you would like to see on the *Measurement View* and press [ENTER].

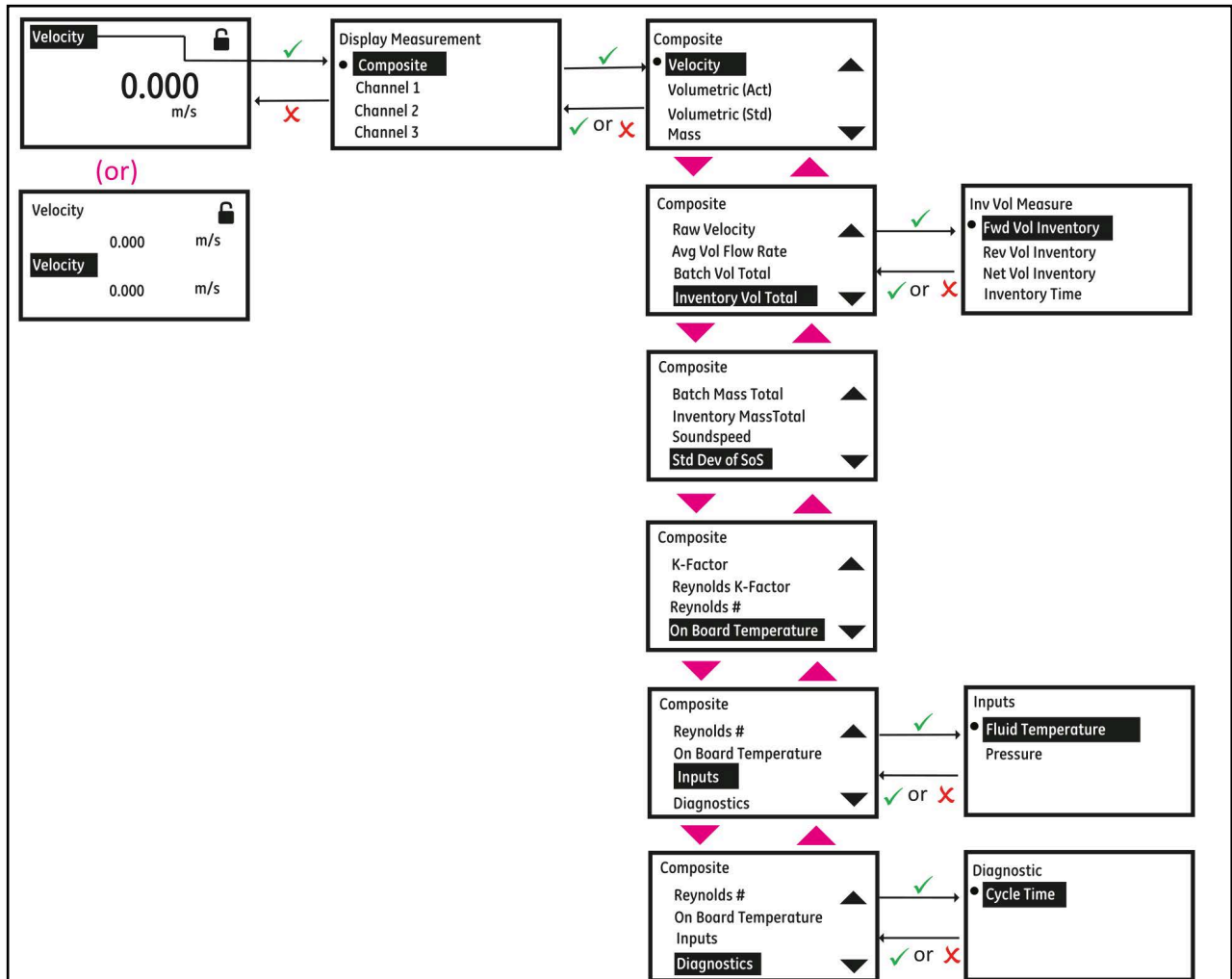

Figure 24: Selecting a Composite Measurement to Display

3.3.1.3 Selecting a Channel Measurement to Display

To select a Channel measurement to display on the *Measurement View*, do the following steps and refer *Figure 25*.

1. Press [▶] until the Measurement name on the meter's *Measurement View* display is highlighted, then press [ENTER].
2. In the *Display Measurement* select [Channel x], then press [ENTER].
3. Then, select the measurement you would like to see on the *Measurement View* and press [ENTER].

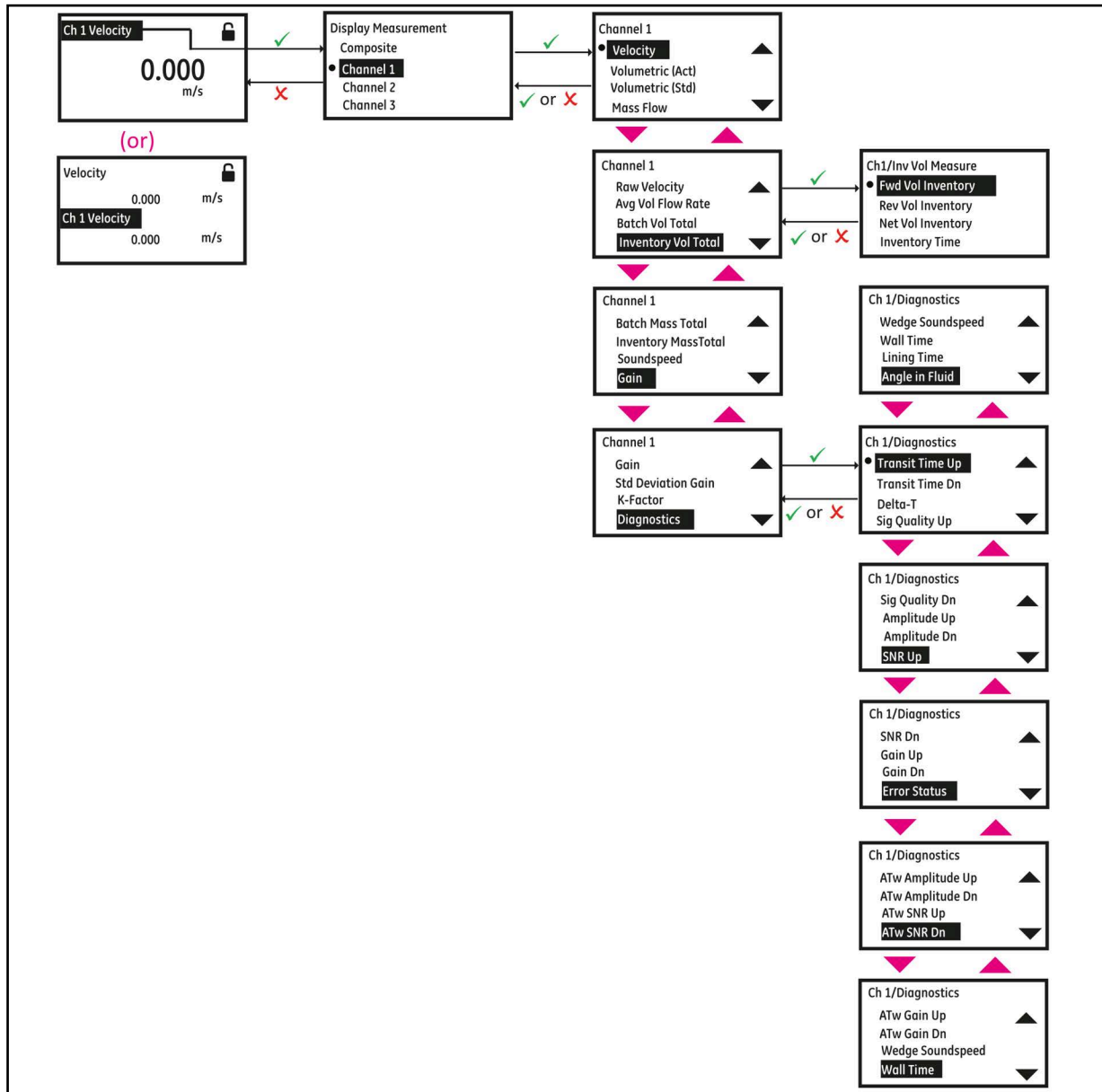

Figure 25: Selecting a Channel Measurement to Display

3.3.1.4 Totalizer Display

The Totalizer display on the *Measurement View* shows the totalized measurements and provides the ability to start, stop and reset totals. Refer to *Figure 23* to set Display format to Totalizer. Do the following steps to select the appropriate Totalizer measurements to view on the *Measurement View*. Refer to *Figure 26*.

1. Press [▶] button on the keypad until the Measurement name on the meter's *Measurement View* display is highlighted, and press [ENTER].
2. In the *Display/Totalizer*, select [Composite] or [Channel x], then press [ENTER].
3. Then, select the totalizer measurement you would like to see on the *Measurement View* and press [ENTER].
4. Press [▶] button on the keypad until the [|| or ▶] is highlighted to stop or start the totalizing respectively.
5. Press [▶] button on the keypad until the [⏏] is highlighted to reset/clear the totalized measurements.

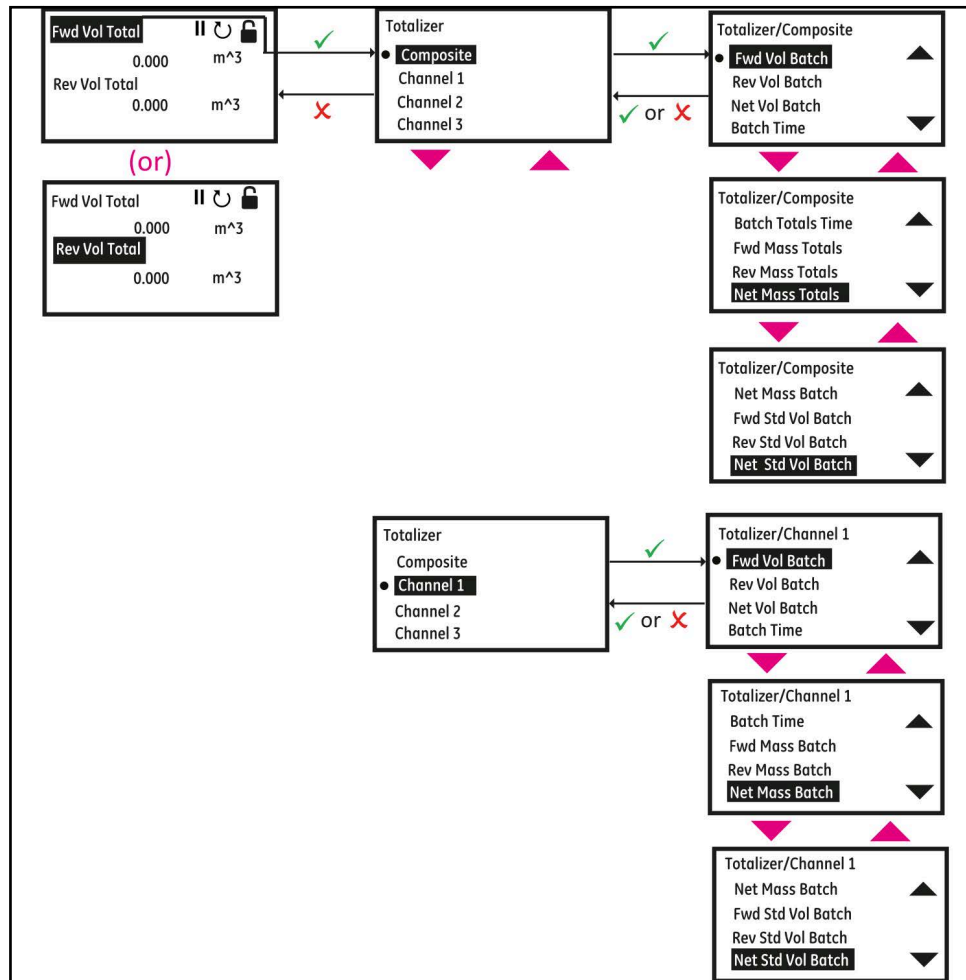

Figure 26: Selecting Totalizer Measurements for Display

3.3.2 Log-in and Primary Pages

To Log-in into the meter perform the following steps:

1. Press [▶] until the lock icon on the meter's *Measurement View* display is highlighted, then press [ENTER].
2. In the *Main Menu* Scroll down and select [Program], then press [ENTER].
3. Scroll and select desired access level [Operator], then press [ENTER].
4. Enter the password Operator access level, and press [ENTER].
5. After completing the log-in steps you will see the primary pages as shown in the *Figure 27*. To move from one page to the next, press [◀] or [▶] and to scroll to options within a page press [▲] and [▼].

Note: For ease of navigation up and down scroll is circular, meaning if you press [▲] when the first option is highlighted, then you will be taken to the last option in the page. Similarly, when you press [▼] when the last option is highlighted, then you will be taken to the first option in the page.

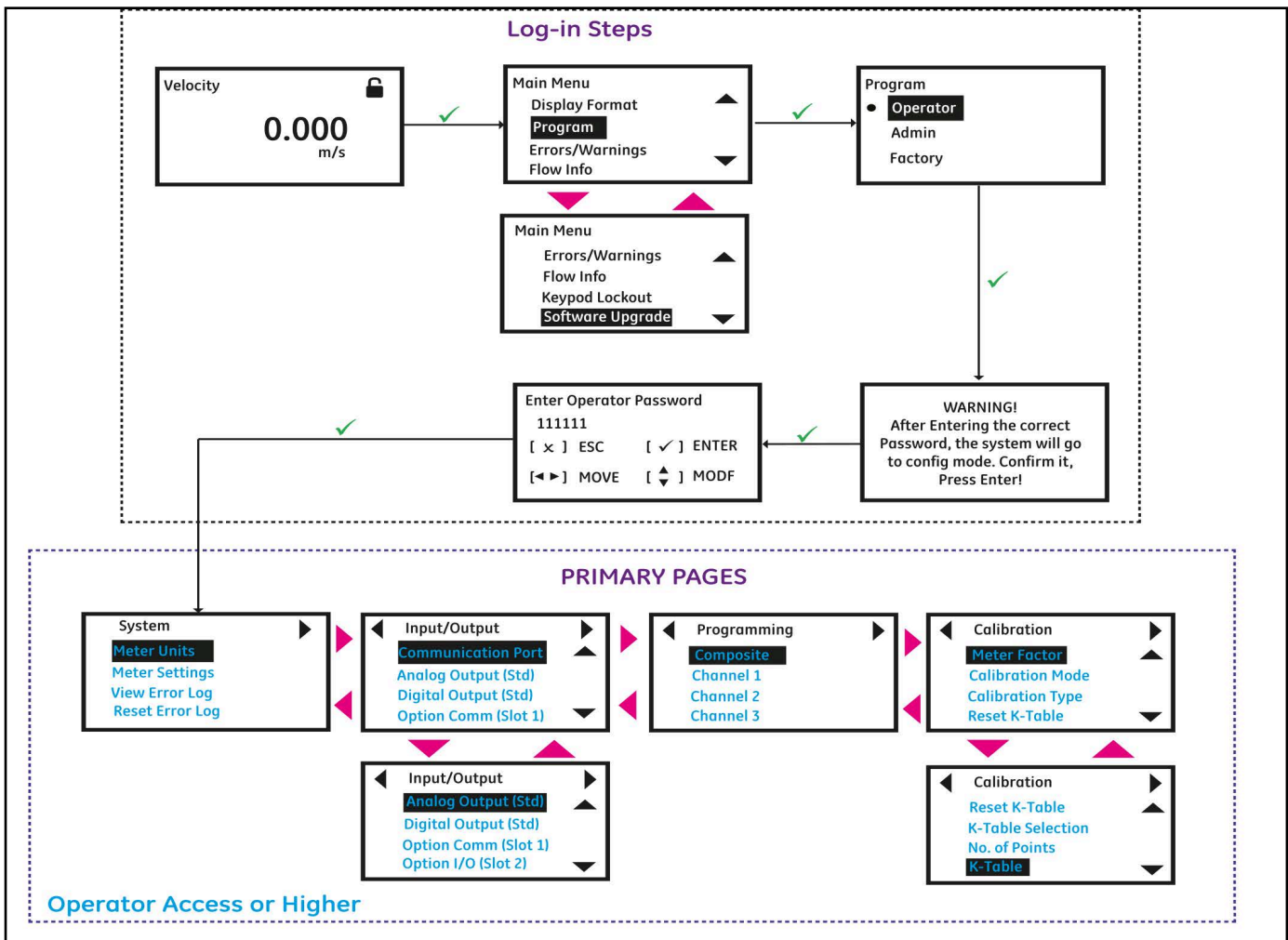

Figure 27: Log-in Steps and Primary pages

IMPORTANT: If the keypad has not been pressed for 5 minutes, the XMT1000 exits the Program and returns to displaying measurements. Because changes can only be retained after the user confirms them, the meter discards any unconfirmed configuration changes.

3.4 Main Program – System Settings

3.4.1 Selecting Units

The operator can select the preferred units of measurements. Use steps as in section “Log-in and Primary Pages” to navigate to the *System* settings page. Then highlight **[Unit Settings]** and press **[ENTER]**, you will now have measurement types listed as in the *Figure 28* below, for which you can select your preferred respective units.

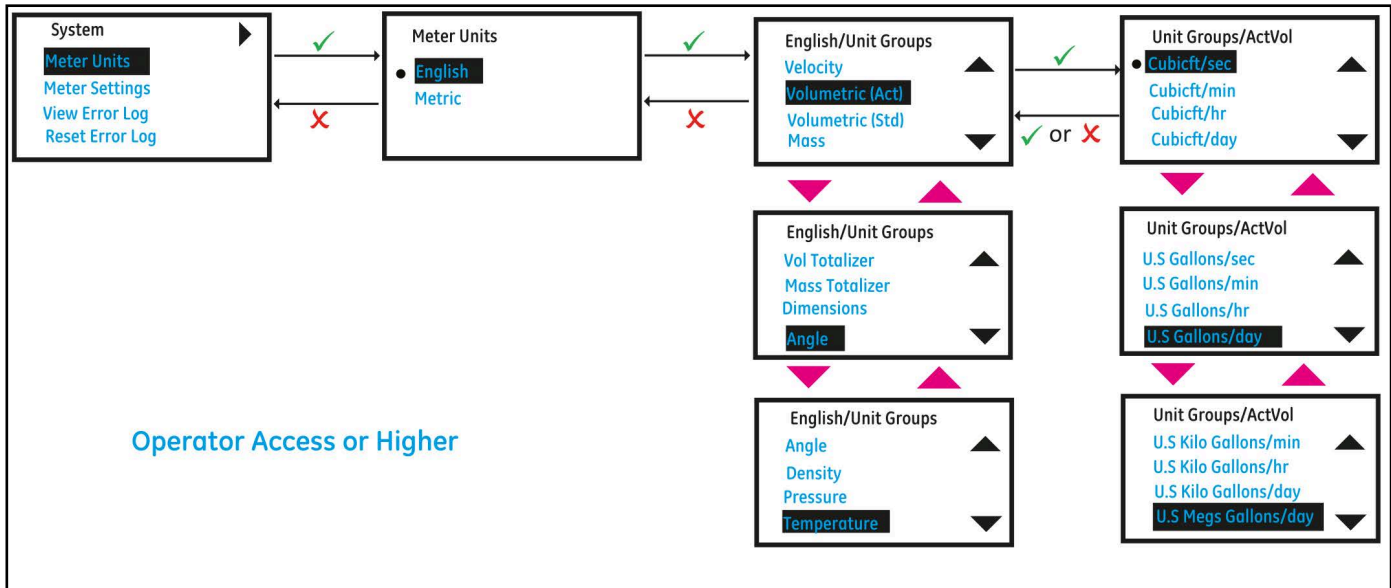

Figure 28: Selecting Units

3.4.1.1 Supported Unit Groups and Units

The *Table 3* specifies the unit groups and its respective units supported in XMT1000.

Table 3: Unit groups and supported units

Unit Group	Supported Metric Units	Supported English Units
Velocity Units	m/s	ft/s
Volumetric Units	m ³ /s, m ³ /min, m ³ /h, m ³ /d, L/s, L/min, L/h, ML/d	ft ³ /s, ft ³ /min, ft ³ /h, ft ³ /d, gal/s, gal/min, gal/h, gal/d, bbl/s, bbl/min, bbl/h, bbl/d, kgal/min, kgal/h, kgal/d, kbbbl/min, kbbbl/h, kbbbl/d, ac-ft/min, ac-ft/h, ac-ft/d, ac-in/s, ac-in/min, ac-in/h, ac-in/d, impgal/s, impgal/min, impgal/h, impgal/d, Mbbbl/d, Mimpgal/d, Mgal/d
Standard Volumetric Units	SL/s, SL/min, SL/hr, SL/d, Sm ³ /s, Sm ³ /min, Sm ³ /hr, Sm ³ /d	SCFH, SCFM, SBBLD, SBBLH, SBBLM, SBBLS, SCFD, SCFS
Mass Units	kg/s, kg/min, kg/h, kg/d, Ton/s, Ton/min, Ton/h, Ton/d	lb/s, lb/min, lb/h, lb/d, klb/s, klb/min, klb/h, klb/d, STon/s, STon/min, STon/h, STon/d
Volumetric Totals Units	m ³ , L, Sm ³ , SL, ML, Mm ³	ft ³ , Mft ³ , gal, Mgal, bbl, Mbbbl, ac-ft, ac-in, impgal, Sft ³
Mass Totals Units	kg, MTon	Lb, STon
Dimension Units	mm	in
Density Units	kg/m ³ , g/cm ³ , Ton/m ³ , kg/L, g/mL, kg/dm ³	oz/in ³ , lb/in ³ , lb/ft ³ , lb/gal
Pressure Units	kg/m ² , Pa, MPa, KPa, bar, mBar, Torr, atm	Psi-g, Psi-a
Angle Units	Degree, Radians	Degree, Radians

Table 3: Unit groups and supported units

Unit Group	Supported Metric Units	Supported English Units
Temperature Units	°C, K, °F, °R	°C, K, °F, °R
Viscosity Units	cSt, m ² /s	ft ² /s

3.4.2 Meter Settings

In order to change the Language, display settings, System Date, Meter Tag, Label, Change password or view About meter, use steps as in section “Log-in and Primary Pages” to navigate to the System settings page. Then highlight **[Meter Settings]** and press **[ENTER]**. Figure 29 below, shows the options available.

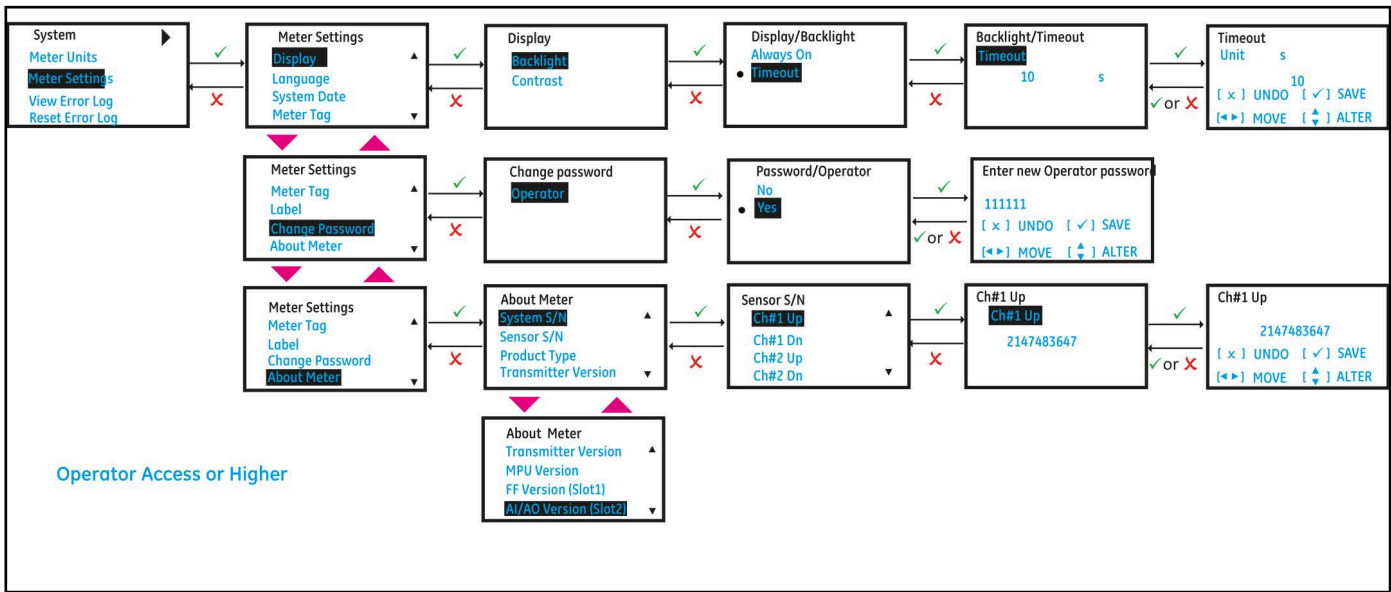

Figure 29: Meter Settings

3.5 Main Program – Inputs and Outputs

3.5.1 Modbus Port Settings

The XMT1000 meter supports digital communications using the MODBUS/RTU protocol, with 3-wire RS-485 as the physical layer interfaces. Baud rate can be specified from 2400 to 115,200 bits per second (bps), with selectable parity, and number of stop bits (Default = 115200, Even, 1 Stop Bit). Use steps as in section “Log-in and Primary Pages” to navigate to the *Input/Output* settings page. Then highlight **[Communication Port]** and press **[ENTER]**. Figure 30 below, shows the options available.

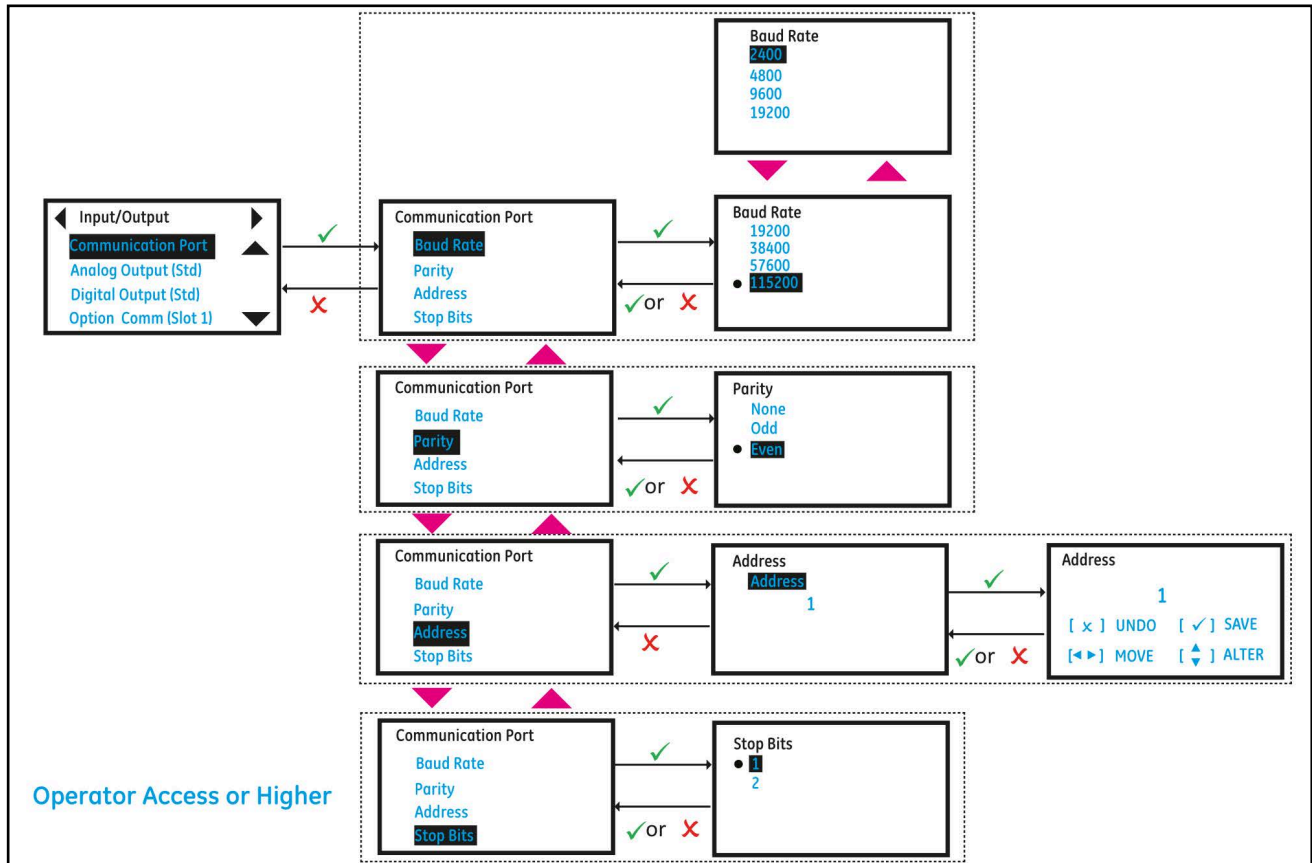

Figure 30: Modbus Port Setting

3.5.2 Standard Analog Output

The XMT1000 has one *Analog Output* and one *Digital Output* in Standard configuration.

3.5.2.1 Setting up Analog Output

The XMT1000 meter has one Analog Output in standard configuration. For additional Analog outputs Optional I/O boards may be purchased. Use steps as in section “Log-in and Primary Pages” to navigate to the *Input/Output* settings page.

1. Then highlight **[Analog Output (Std)]** and press **[ENTER]**.
2. If you do not wish to connect an Analog Output, you should turn Analog Output selection to OFF.
3. If you are connecting an Analog Output, choose 4–20mA option. The *Figure 31* below, shows the options available.
4. Select the Measurement to be sent out on the 4–20mA output, followed by the **[Base Value]** and **[Full Value]** selection. Refer *Table 4* to see measurement options available for Analog output.
5. Select **[Error Handling]**. Refer to section 3.5.2.2 to choose an option that suits your needs.

Table 4: Measurement Options for Analog output

Measurement Channel	Measurement Options for Analog Output
Composite	Velocity, Actual Volumetric, Standard Volumetric, Mass Flow, Average Volumetric Flow Rate, Sound speed, Reynolds#
Channel x	Velocity, Actual Volumetric, Standard Volumetric, Mass Flow, Average Volumetric Flow rate, Sound speed, Standard Deviation of Gain, Gain and SNR

3.5.2.2 Understanding the Error Handling Option

The following *Table 5* shows the response to each of the Error Handling options. For a multi-channel meter, the **[Path Error Handling]** set to ON (see *Figure 45*) changes the Output response. See *Table 6* for Analog Output response with **[Path Error Handling]** set to ON.

Note: *Table 6* assumes Composite Actual Volumetric is chosen as Measurement for Analog Output.

Table 5: Analog Output Error Handling options

Option	Output Response
Low	Forces Output to 3.6 mA on error
High	Forces Output to 20 mA on error
Hold	Holds the last "good" reading
Other	Enables the user to enter a value between 4mA and 20mA, to be output during an error

Table 6: Analog Output Error Handling with Path Error Handling set to ON

Ch1 in Error	Ch2 in Error	Ch3 in Error	Error displayed in Meter	Expected Composite Volumetric(Act) behavior	Analog Output Response
No	No	No	No Error	Measured Composite Volumetric(Act)	mA proportional to the Measured Composite Volumetric(Act)
Yes	No	No	E22: SingleChAccuracy	Measured Composite Volumetric(Act)	mA proportional to the Measured Composite Volumetric(Act)
No	Yes	No	E22: SingleChAccuracy	Measured Composite Volumetric(Act)	mA proportional to the Measured Composite Volumetric(Act)
No	No	Yes	E22: SingleChAccuracy	Measured Composite Volumetric(Act)	mA proportional to the Measured Composite Volumetric(Act)
Yes	Yes	No	E23: MultiChAccuracy	Measured Composite Volumetric(Act)	mA proportional to the Measured Composite Volumetric(Act)
No	Yes	Yes	E23: MultiChAccuracy	Measured Composite Volumetric(Act)	mA proportional to the Measured Composite Volumetric(Act)
Yes	No	Yes	E23: MultiChAccuracy	Measured Composite Volumetric(Act)	mA proportional to the Measured Composite Volumetric(Act)
Yes	Yes	Yes	E23: MultiChAccuracy	Measured Composite Volumetric(Act) will hold the last good value	mA value based on the [Error Handling] setting

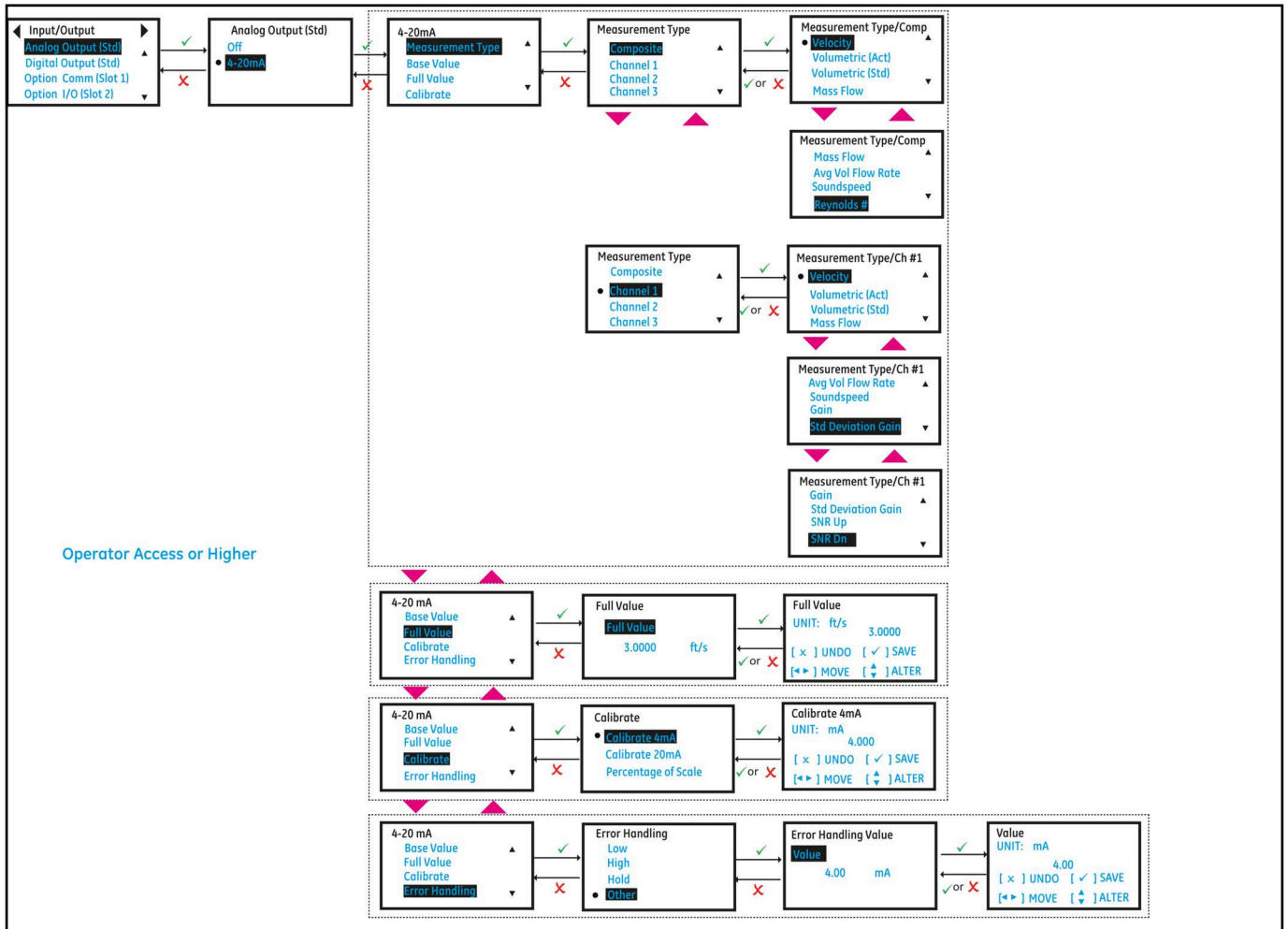

Figure 31: Setting up Analog Output

3.5.2.3 Calibrating Analog Output

To calibrate Analog Output, use steps as in section “Log-in and Primary Pages” to navigate to the *Input/Output* settings page. You may use a multimeter or DCS/SCADA to calibrate the Analog Output. Regardless of whether multimeter or DCS/SCADA is used, the steps below remain the same. For better readability, the steps below only indicate multimeter and does not repeat multimeter or DCS/SCADA.

1. Turn ON the multimeter (if used), and set it to measure Current (mA) DC. Connect test lead from positive side (Aout+) of the Main Analog Output to the positive terminal of multimeter, and the negative lead to the negative terminal (Aout-).
2. Then in Meter Menu highlight **[Analog Output (std)]** and press **[ENTER]**. Then highlight **[4-20mA]** and press **[ENTER]**.
3. Scroll down and select **[Calibrate]** option.
4. Select **[Calibrate 4mA]** and check if the reading on the multimeter reads 4.00mA \pm 0.01mA. If the value on the multimeter is not 4.00mA \pm 0.01mA, input the value read on the multimeter into the *Calibrate 4mA* value and press **[ENTER]**. Check multimeter again verify the Current reads 4.00mA within \pm 0.01mA.
5. Select **[Calibrate 20mA]** and check if the reading on the multimeter reads 20.00mA \pm 0.01mA. If the value on the multimeter is not 20.00mA \pm 0.01mA, input the value read on the multimeter into the *Calibrate 20mA* value and press **[ENTER]**. Check multimeter again verify the Current reads 20.00mA within \pm 0.01mA.

6. Select **[Percentage of Scale]** and adjust the scale to 0.00% and press **[ENTER]**, then verify the reading on the multimeter is 4.00mA within ± 0.01 mA. Then adjust the scale to 50.00% and press **[ENTER]**, then verify the reading on the multimeter is 12.00mA within ± 0.01 mA. Then adjust the scale to 100.00% and press **[ENTER]**, then verify the reading on the multimeter is 20.00mA within ± 0.01 mA.
7. If Steps 4, 5, and 6 were successfully completed and verified, the Analog output is successfully calibrated.

3.5.3 Standard Digital Output

3.5.3.1 Setting up Pulse Output

To program a Pulse Output, use steps as in section "Log-in and Primary Pages" to navigate to the *Input/Output* settings page:

1. In Meter Menu highlight **[Digital Output (Std)]** and press **[ENTER]**. Then select **[Pulse]** option.
2. Setup the **[Polarity]**, **[Measurement Type]**, **[Pulse Value]**, **[Pulse width]**, **[Test Pulse]** and **[Error Handling]** options to suit your needs. The *Figure 32* below, shows the available options. Also refer to the *Table 7* below to understand each option.

Table 7: Pulse Output Options

Option	Functional Description
Polarity	Choose the Negative or Positive edge of the pulse
Measurement Type	Choose the channel and Measurement to output
Pulse Value	Choose how many units of the chosen measurement is accumulated before a pulse is output
Pulse Width	Choose the duration of each pulse that is output IMPORTANT: Make sure the meter is not configured to output more than one pulse during this time, as this could lead to missed pulses.
Test Pulse	Enter the number of pulse count to be tested
Error Handling	Choose the Pulse output response during an error condition

For measurement options available on Pulse Output refer to *Table 8*.

Table 8: Measurement options for Pulse Output

Measurement Channel	Measurement Options for Pulse Output
Composite	Forward Volumetric Totals, Reverse Volumetric Totals, Net Volumetric Totals, Forward Mass Totals, Reverse Mass Totals, Net Mass Totals, Forward Std Volumetric Totals, Reverse Std Volumetric Totals, Net Std Volumetric Totals
Channel x	Forward Volumetric Totals, Reverse Volumetric Totals, Net Volumetric Totals, Forward Mass Totals, Reverse Mass Totals, Net Mass Totals, Forward Std Volumetric Totals, Reverse Std Volumetric Totals, Net Std Volumetric Totals

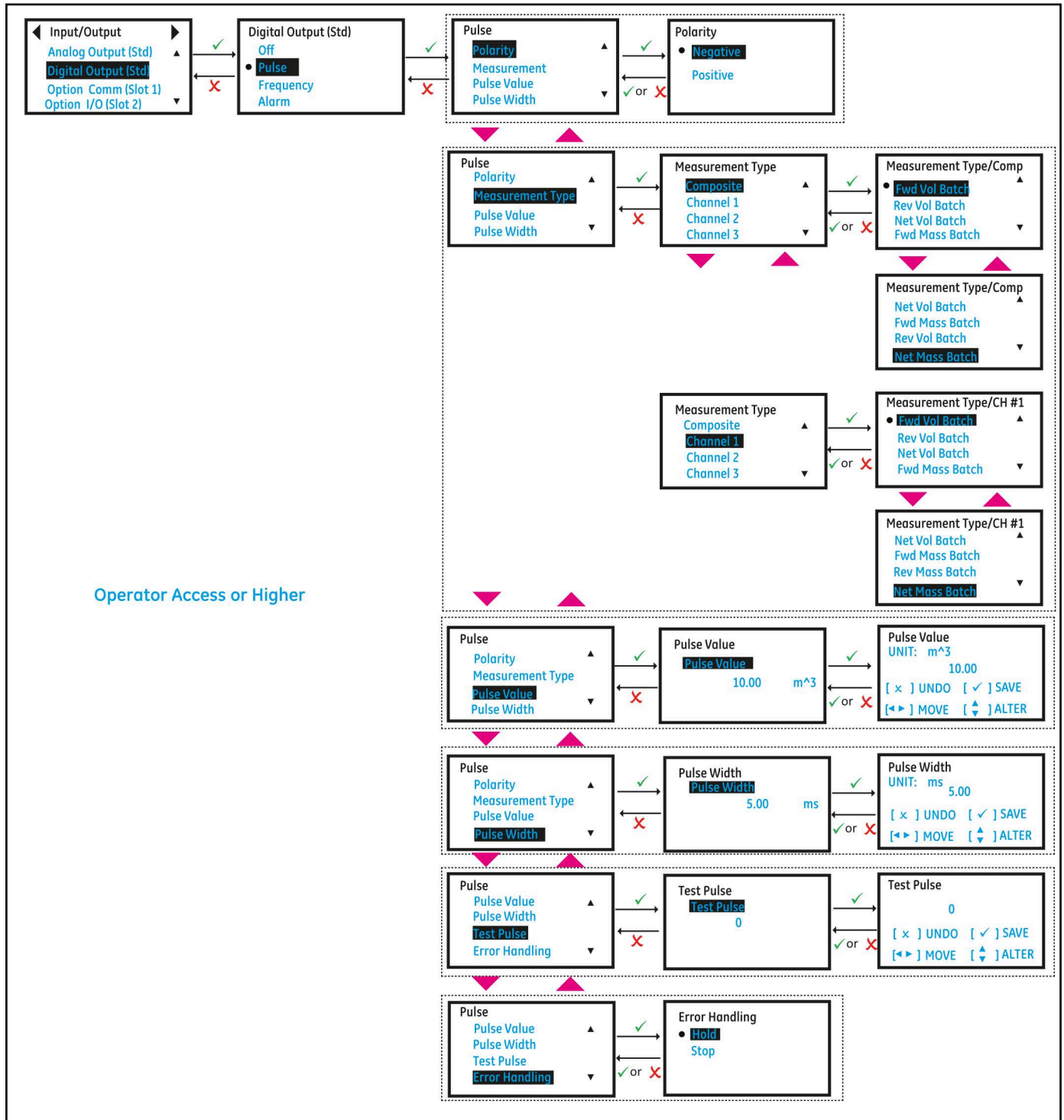

Figure 32: Setting up Pulse Output

3.5.3.2 Setting up Frequency Output

To program a *Frequency Output*, use steps as in section “Log-in and Primary Pages” to navigate to the *Input/Output* settings page:

1. In Meter Menu highlight **[Digital Output (Std)]** and press **[ENTER]**. Then highlight **[Frequency]** option and press **[ENTER]**.
2. Setup the **[Measurement Type]**, **[Base Value]**, **[Full Value]**, **[Full Frequency]**, **[Test Pulse]** and **[Error Handling]** options to suit your needs. The *Figure 33* below, shows the available options. Also refer to the *Table 10* below to understand each option.

For measurement options available on Frequency Output refer to *Table 9*.

Table 9: Measurement options for Frequency Output

Measurement Channel	Measurement Options for Frequency Output
Composite	Velocity, Actual Volumetric, Standard Volumetric, Mass Flow, Average Volumetric Flow Rate, Sound speed, Reynolds #
Channel x	Velocity, Actual Volumetric, Standard Volumetric, Mass Flow, Average Volumetric Flow rate, Sound speed, Standard Deviation of Gain, Gain and SNR

Table 10: Frequency Output Options

Option	Functional Description
Measurement Type	Choose the channel and Measurement to output
Base Value	Enter measurement value that should correspond to the min. value of the frequency range
Full Value	Enter measurement value that should correspond to the max. value of the frequency range
Full Frequency	Enter the highest value of the Frequency range you want to output
Test Pulse	Enter the number of pulse count to be tested.
Error Handling	Choose the Frequency output response during an error condition: Low, High, Hold, or Other Value. During a meter error, the chosen Error Handling value will be sent to the Frequency Output.

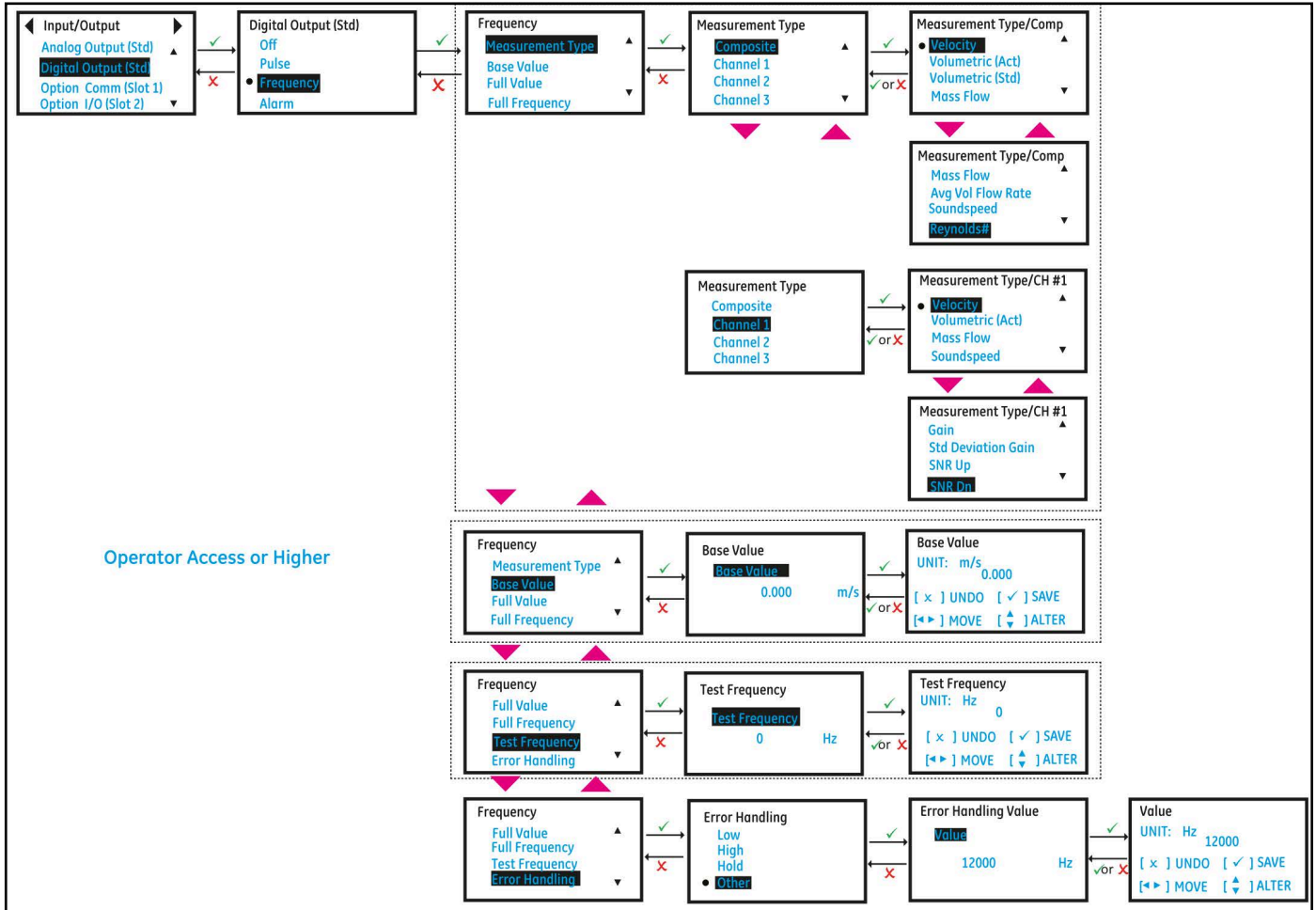

Figure 33: Setting up Frequency Output

3.5.3.3 Understanding the Error Handling Option

The Table 11 shows the response to each of the Frequency Output Error Handling options. For a multi-path meter, the [Path Error Handling] set to ON (see Figure 45) changes the Output response. See Table 12 for Frequency Output response with [Path Error Handling] set to ON.

Note: Table 12 assumes Composite Actual Volumetric is chosen as Measurement Type for Frequency Output and the Path configuration is 3 paths.

Table 11: Frequency Output Error Handling options

Option	Output Response
Low	Forces Output to 0Hz on error
High	Forces Output to 10000Hz on error
Hold	Holds the last “good” Hz reading
Other	Enables the user to enter a value between 0Hz and 12000Hz to be output during an error

Table 12: Frequency Output Error Handling with Path Error Handling set to ON

Ch1 in Error	Ch2 in Error	Ch3 in Error	Error displayed in Meter	Expected Composite Volumetric(Act) behavior	Frequency Output Response
No	No	No	No Error	Measured Composite Volumetric(Act)	Frequency proportional to the Measured Composite Volumetric(Act)
Yes	No	No	E22: SingleChAccuracy	Measured Composite Volumetric(Act)	Frequency proportional to the Measured Composite Volumetric(Act)
No	Yes	No	E22: SingleChAccuracy	Measured Composite Volumetric(Act)	Frequency proportional to the Measured Composite Volumetric(Act)
No	No	Yes	E22: SingleChAccuracy	Measured Composite Volumetric(Act)	Frequency proportional to the Measured Composite Volumetric(Act)
Yes	Yes	No	E23: MultiChAccuracy	Measured Composite Volumetric(Act)	Frequency proportional to the Measured Composite Volumetric(Act)
No	Yes	Yes	E23: MultiChAccuracy	Measured Composite Volumetric(Act)	Frequency proportional to the Measured Composite Volumetric(Act)
Yes	No	Yes	E23: MultiChAccuracy	Measured Composite Volumetric(Act)	Frequency proportional to the Measured Composite Volumetric(Act)
Yes	Yes	Yes	E23: MultiChAccuracy	Measured Composite Volumetric(Act) will hold the last good value	Frequency value based on the [Error Handling] setting

3.5.3.4 Setting up Alarm Output

To program an *Alarm Output*, use steps as in section “Log-in and Primary Pages” to navigate to the *Input/Output* settings page:

1. In Meter Menu highlight **[Digital Output (Std)]** and press **[ENTER]**. Then select **[Alarm]** option.
2. Select the **[Alarm State]**, **[Alarm type]**, **[Measurement Type]**, **[Test Alarm]** and **[Alarm Value]** options to suit your needs. The *Figure 34* below, shows the available options. Also refer to the *Table 14* below to understand each option.

For measurement options available on Alarm Output refer to *Table 13*.

Table 13: Measurement options for Alarm output

Measurement Channel	Measurement Options for Frequency Output
Composite	Velocity, Actual Volumetric, Standard Volumetric, Mass Flow, Average Volumetric Flow Rate, Sound speed, Reynolds #
Channel x	Velocity, Actual Volumetric, Standard Volumetric, Mass Flow, Average Volumetric Flow rate, Sound speed, Standard Deviation of Gain, Gain and SNR

Table 14: Alarm Output Options

Option	Functional Description
Alarm State	Choose if the Alarm State should be Normally Open, Normally Closed or Failsafe
Alarm Type	For <i>Alarm State</i> selected as <i>Normally Open</i> or <i>Normally Closed</i> , <i>Alarm Type</i> can be set to <i>High</i> or <i>Low</i> . If set to high, Alarm will be triggered if the selected <i>Measurement</i> goes above the programmed <i>Alarm Value</i>
Measurement Type	Choose the channel and <i>Measurement</i> that is monitored for Alarm Trigger
Test Alarm	Choose the options "Off" or "On" for Alarm
Alarm Value	Enter measurement value that should be a trigger point

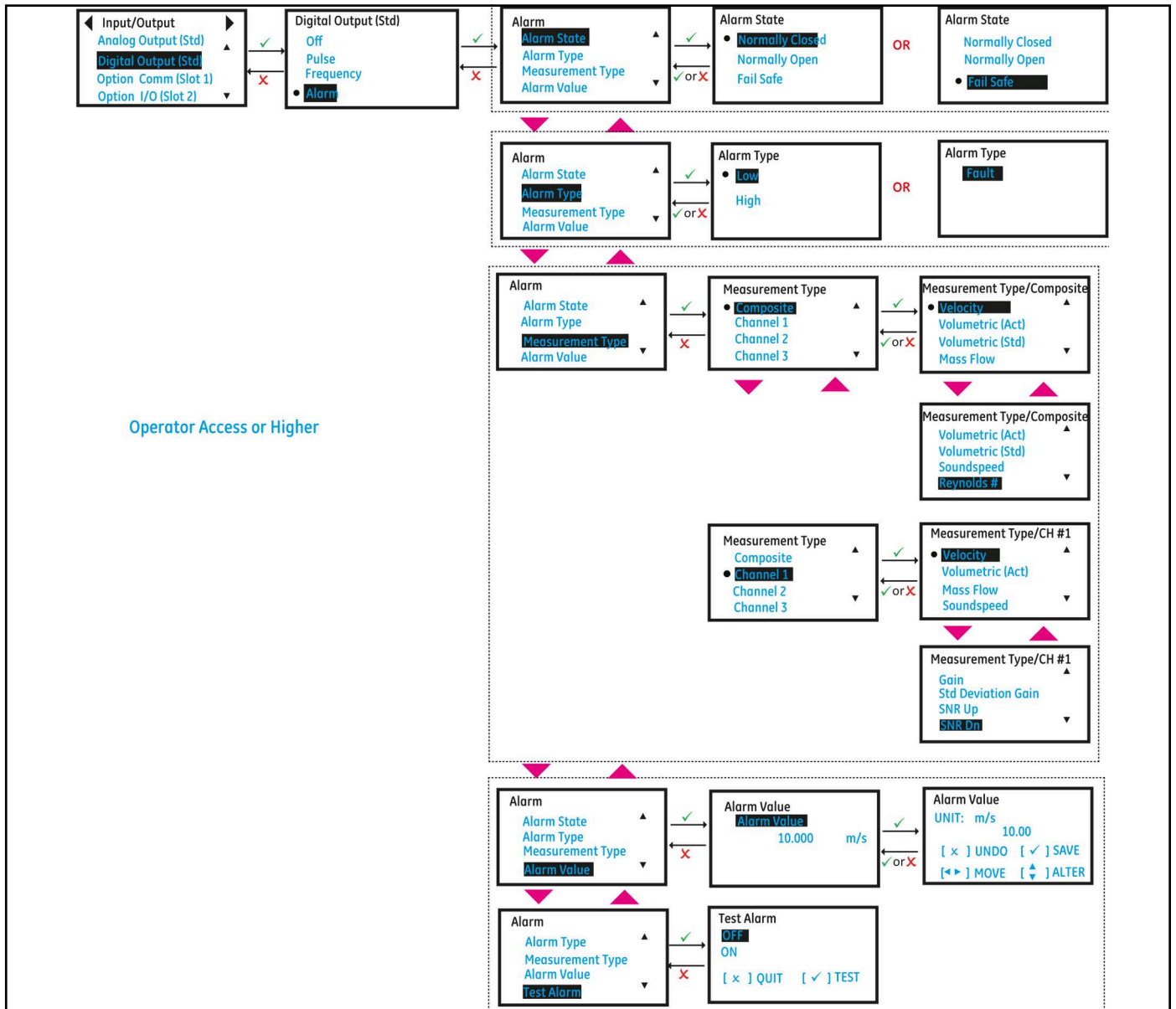

Figure 34: Setting up Alarm Output

3.5.4 Option Comm Slot-1 (optional)

3.5.4.1 Option Slot-1 Configured as HART

Use steps as in section “Log-in and Primary Pages” to navigate to the *Input/Output* settings page.

1. Then highlight **[Option Comm (Slot 1)]** and press **[ENTER]**. Then highlight **[HART]** and press **[ENTER]**.
2. You can set **Analog Output** with HART option. Refer to *Figure 35* and *Figure 31*.
3. You can also view the HART hardware and software revision numbers in **About HART** option.

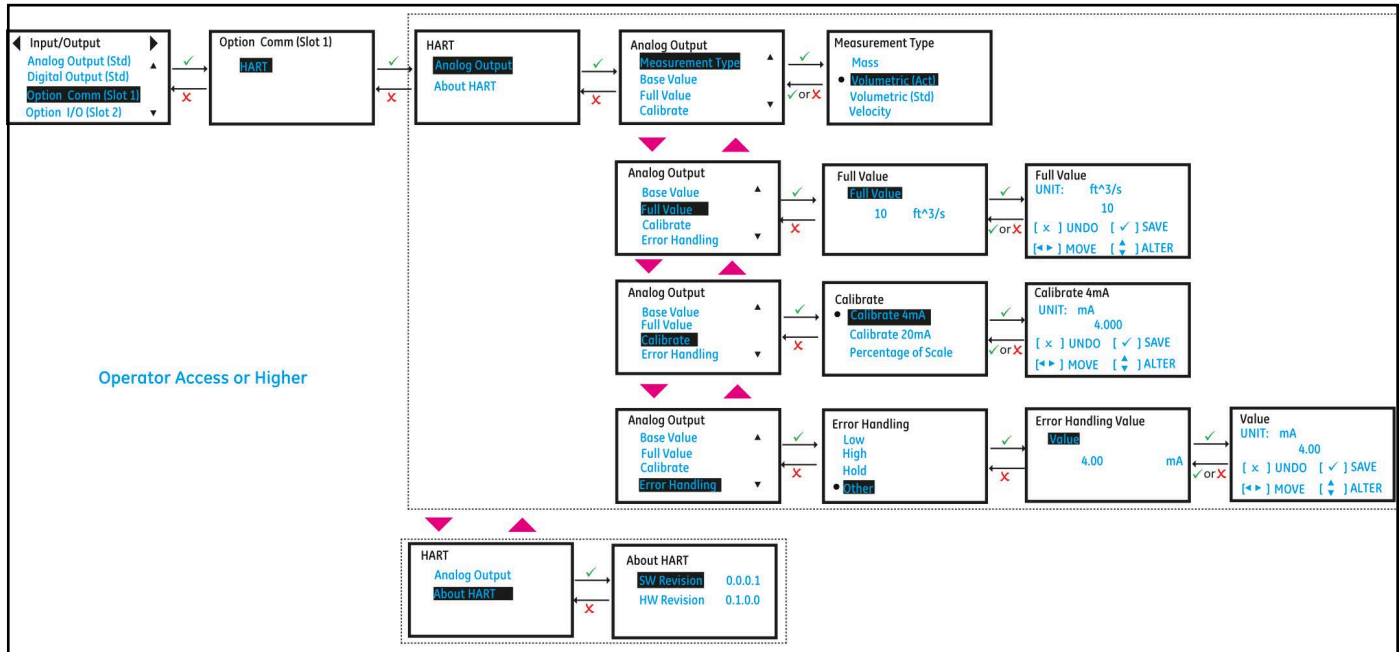

Figure 35: Option Slot-1 Configured as HART

3.5.4.2 Option Slot-1 Configured as FF

Use steps as in section “Log-in and Primary Pages” to navigate to the *Input/Output* settings page.

1. Highlight **[Option Comm (Slot 1)]** and press **[ENTER]**. Then highlight **[FF]** and press **[ENTER]**.
2. You can view the FF hardware and software revision numbers in **About FF** option.

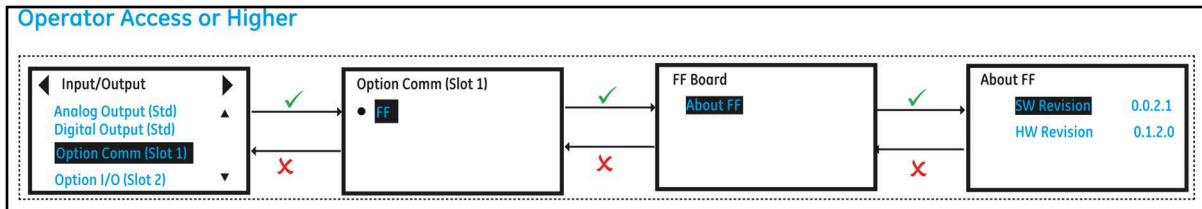

Figure 36: Option Slot-1 Configured as FF

3.5.5 Option I/O Slot-2 (Optional)

For extended I/O capability XMT1000 supports an Optional I/O that provides 2 additional Analog Outputs (AO-AO), with up to 2 Analog Inputs (AI-AI) or 2 RTD (R-R) inputs. See *Table 15* for all available options.

Table 15: Optional I/O available options

XMT1000 Option Code #	Input / Output Options Available
1	AO-AO-AI-AI
2	AO-AO-AI-R 3 Wire, 100 Ohm
3	AO-AO-R-R 3 Wire, 100 Ohm
4	AO-AO-AI-R 4 Wire, 100 Ohm
5	AO-AO-R-R 4 Wire, 100 Ohm
6	AO-AO-AI-R 3 Wire, 1000 Ohm
7	AO-AO-R-R 3 Wire, 1000 Ohm
8	AO-AO-AI-R 4 Wire, 1000 Ohm
9	AO-AO-R-R 4 Wire, 1000 Ohm

In this chapter AO-AO-AI-R 3 Wire, 1000 Ohm option will be used as an example. Other options have similar capabilities and menu map.

3.5.5.1 Option IO (Slot2): Setting up Analog Output

Use steps as in section "Log-in and Primary Pages" to navigate to the *Input/Output* settings page.

1. Highlight **[Option I/O (Slot 2)]** and press **[ENTER]**.
2. Then highlight **[AO-AO-AI-R-1000-3W]** and press **[ENTER]**. Then highlight **[Analog Output(S2:1)]** or **[Analog Output(S2:2)]** and press **[ENTER]**.
3. If you do not wish to connect an Analog Output, you should turn Analog Output selection to OFF.
4. If you are connecting an Analog Output, choose 4-20mA option. *Figure 37* below, shows the options available.
5. Select the Measurement to be sent out on the 4-20mA output, followed by the **[Base Value]** and **[Full Value]** selection. Refer to *Table 4* to see measurement options available for Analog output.
6. Select **[Error handling]**. Refer to *Section 3.5.5.2* to choose an option that suits your needs.

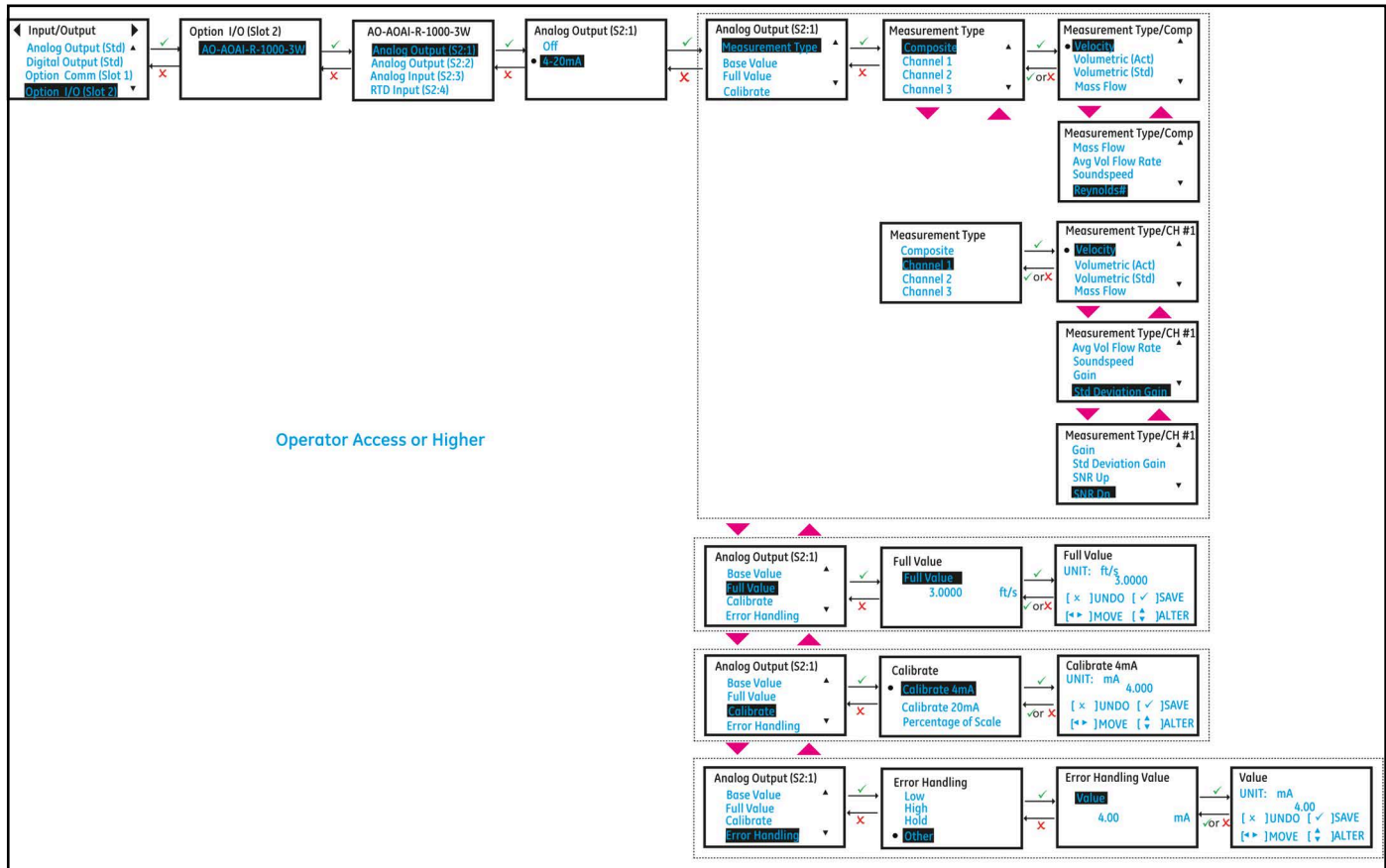

Figure 37: Setting up Option I/O Analog Output

3.5.5.2 Option IO (Slot2): Calibrating Analog Output

To calibrate Option I/O Analog Output, use steps as in section “Log-in and Primary Pages” to navigate to the *Input/Output* settings page. You may use a multimeter or DCS/SCADA to calibrate the Analog Output. Regardless of whether multimeter or DCS/SCADA is used, the steps below remain the same. For better readability, the steps below only indicate multimeter and does not repeat multimeter or DCS/SCADA.

Note: *Optional I/O menu uses Slot:Channel convention for clarity. For Example, Analog Output(S2:1) indicates Analog Output on Slot 2, Channel 1. Optional I/O is installed in the Slot2 of the electronics stack.*

1. Connect the Analog Output as in Figure 38.
2. Turn ON the multimeter (if used) and set it to measure Current (mA) DC. Connect test lead from positive side (Analog Output Channel 1: **I/O 1**) or (Analog Output Channel 2: **I/O 3**) of the optional I/O Analog Output to the positive terminal of multimeter, and the negative lead to the negative terminal (Analog Output Channel 1: **I/O 2**) or (Analog Output Channel 2: **I/O 4**).
3. Highlight **[Option I/O (Slot 2)]** and press **[ENTER]**.
4. Then highlight **[AO-AO-AI-R-1000-3W]** and press **[ENTER]**. Then highlight **[Analog Output(S2:1)]** or **[Analog Output(S2:2)]** and press **[ENTER]**.
5. Then highlight **[4-20mA]** and press **[ENTER]**.
6. Scroll down and select **[Calibrate]** option.
7. Select **[Calibrate 4mA]** and check if the reading on the multimeter reads 4.00mA ± 0.01mA. If the value on the multimeter is not 4.00mA ± 0.01mA, input the value read on the multimeter into the Calibrate 4mA value and press **[ENTER]**. Check the multimeter again verify that the Current reads 4.00mA within ±0.01mA.
8. Select **[Calibrate 20mA]** and check if the reading on the multimeter reads 20.00mA ± 0.01mA. If the value on the multimeter is not 20.00mA ± 0.01mA, input the value read on the multimeter into the Calibrate 20mA value and press **[ENTER]**. Check the multimeter again verify that the Current reads 20.00mA within ±0.01mA.

9. Select **[Percentage of Scale]** and adjust the scale to 0.00% and press **[ENTER]**, then verify the reading on the multimeter is 4.00mA within ± 0.01 mA. Adjust the scale to 50.00% and press **[ENTER]**, then verify the reading on the multimeter is 12.00mA within ± 0.01 mA. Adjust the scale to 100.00% and press **[ENTER]**, then verify the reading on the multimeter is 20.00mA within ± 0.01 mA.
10. If Steps 4, 5 and 6 were successfully completed and verified, the Analog output is successfully calibrated.
11. Once calibration is complete, select either **[Save]** or **[Save & Logout]** option to save calibration data.

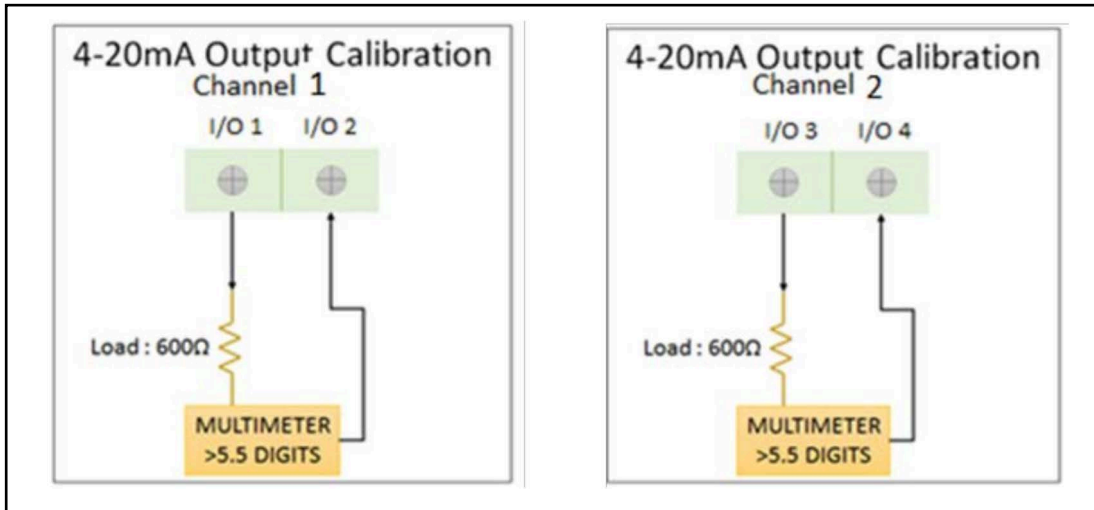

Figure 38: Optional I/O Analog Output Channel 1 and Channel 2 connections

3.5.5.3 Option IO (Slot2): Setting up Analog Input

Use steps as in section “Log-in and Primary Pages” to navigate to the *Input/Output* settings page.

1. Highlight **[Option I/O (Slot 2)]** and press **[ENTER]**.
2. Then highlight **[AO-AO-AI-R-1000-3W]** and press **[ENTER]**. Then highlight **[Analog Input(S2:3)]** and press **[ENTER]**.
3. If you do not wish to connect an Analog Input, you should turn Analog Input selection to OFF.
4. If you are connecting an Analog Input, choose **[4-20mA]** option. *Figure 39* below, shows the options available.
5. Select the Measurement to input over 4-20mA input, followed by the **[Base Value]** and **[Full Value]** selection. Refer to *Table 4* to see measurement options available for Analog output.

Table 16: Analog Input Measurement Types

Measurement Options for Analog Input

Temperature, Pressure

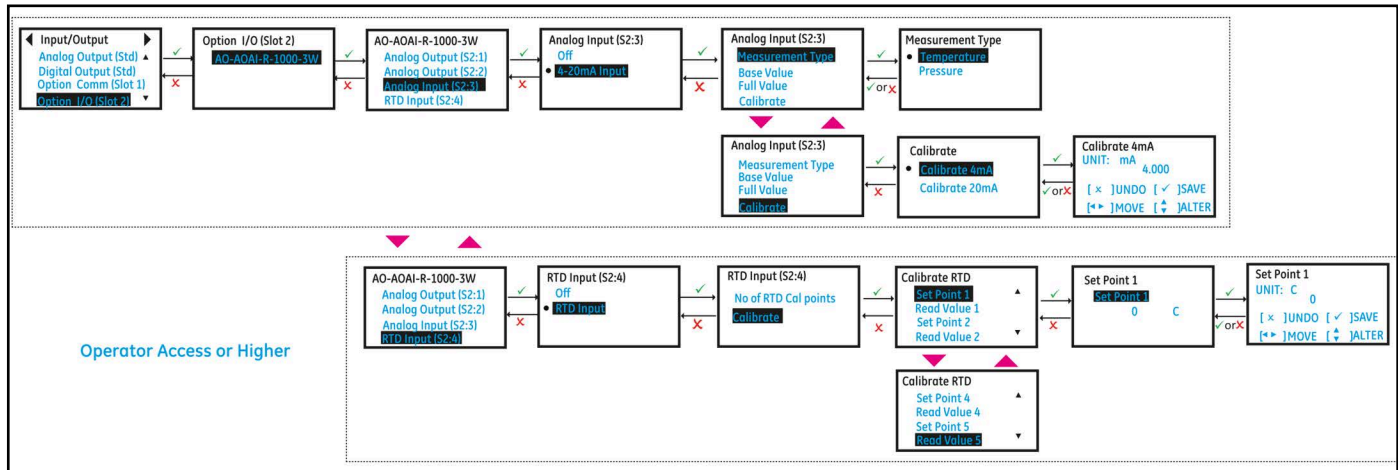

Figure 39: Setting up Option I/O Analog Input/RTD Input

3.5.5.4 Option IO (Slot2): Calibrating Analog Input

To calibrate Option I/O Analog Input, use steps as in section “Log-in and Primary Pages” to navigate to the Input/Output settings page.

Note: Optional I/O menu uses Slot:Channel convention for clarity. For Example, Analog Input(S2:3) indicates Analog Input on Slot 2, Channel 3. Optional I/O is installed in the Slot2 of the electronics stack.

1. Connect the Analog Input as in Figure 40.
2. Turn ON the calibrator and set it to measure Current (mA) DC. Connect test lead from positive side (Analog Input Channel 3: I/O 7) of the optional I/O Analog Input to the positive terminal of multimeter, and the negative lead to the negative terminal (Analog Output Channel 3: I/O 8).
3. Highlight **[Option I/O (Slot 2)]** and press **[ENTER]**.
4. Then highlight **[AO-AO-AI-R-1000-3W]** and press **[ENTER]**. Then highlight **[Analog Input(S2:3)]** and press **[ENTER]**.
5. Then highlight **[4-20mA]** and press **[ENTER]**.
6. Scroll down and select **[Calibrate]** option.
7. Select **[Calibrate 4mA]** in the meter Menu. Set **[4mA]** current on calibrated current source and check the reading on the XMT1000 is 4.00mA ±0.01mA. Once reading is stabilized on the LCD, Press **[ENTER]** to accept the current 4 mA value or Press **[ESCAPE]** to cancel the calibration.
8. Select **[Calibrate 20mA]** in the meter Menu. Set **[20mA]** current on calibrated current source and check the reading on the XMT1000 is 20.00mA ±0.01mA. Once reading is stabilized on the LCD, Press **[ENTER]** to accept the current 20 mA value or Press **[ESCAPE]** to cancel the calibration.
9. Once calibration is complete, select either **[Save]** or **[Save & Logout]** option to save calibration data.

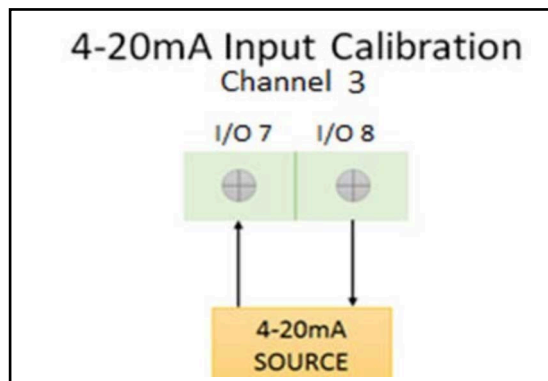

Figure 40: Option I/O Analog Input connections

3.5.5.5 Option IO (Slot2): Calibrating RTD Input

1. Insert RTD sensor and master RTD in temperature bath and turn ON, and set it to desired temperature set point.
2. Use steps as in section "Log-in and Primary Pages" to navigate to the *Input/Output* settings page. Refer to *Figure 39* above, highlight **[Option I/O (Slot 2)]** and press **[ENTER]**.
3. Highlight **[AO-AO-AI-R-1000-3W]** and press **[ENTER]**. Then highlight **[RTD Input(S2:4)]** and press **[ENTER]**.
4. Highlight **[RTD Input]** and press **[ENTER]**.
5. Set the number of Calibration points by selecting **[No. of RTD Cal points]**.
6. Scroll down and select **[Calibrate]** option.
7. Select **[Set point 1]**, press **[ENTER]** and set [Set point 1] to the temperature value selected on the calibrator. Press **[ESCAPE]**.
8. Select **[Read Value 1]**, press **[ENTER]**, and check the **[Read Value 1]** reads **[Set point 1]** value. Once reading is stabilized on the **[Read Value 1]**, Press **[ENTER]** to accept the value or Press **[ESCAPE]** to cancel the calibration.
9. Repeat steps 7 and 8 for other set points.
10. Once all set points are calibrated, select either **[Save]** or **[Save & Logout]** option to save calibration data.

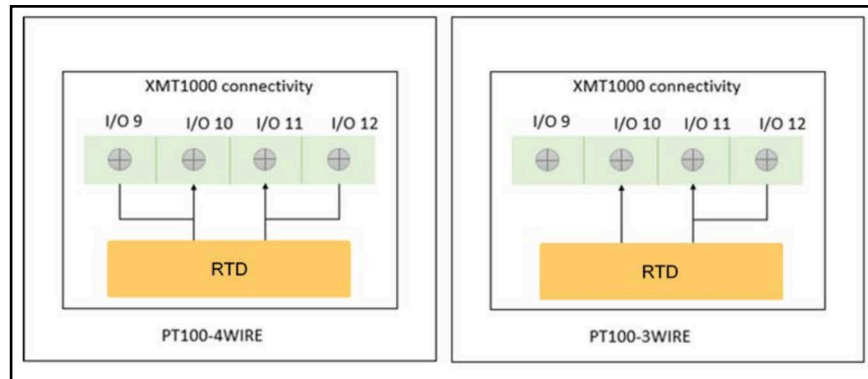

Figure 41: Option I/O RTD Connection

3.5.6 Analog Output (SIL) - (Optional)

For the SIL analog output, you **MUST** use this terminal block and location for programming. Use this section for selecting the measurement type, setting base and full scale values, calibrating and testing the SIL analog output, and setting error handling.

Use steps as in section "Log-in and Primary Pages" to navigate to the *Input/Output* settings page.

1. Then highlight **[Analog Output (SIL)]** and press **[ENTER]**.
2. Select the Measurement to be sent out on the 4-20mA output, followed by the **[Base Value]** and **[Full Value]** selection.
3. Select error handling with either "Low" or "High". For PanaView select either "Fire-Low" or "Fire-High". Low is a 3.6mA signal and High is a 21mA.
4. See next section for calibrating SIL analog output.

3.5.6.1 Calibrating SIL Analog Output

You may use a multimeter or DCS/SCADA to calibrate the SIL Analog Output. Regardless of whether multimeter or DCS/SCADA is used, the steps below remain the same. For better readability, the steps below only indicate multimeter and does not repeat DCS/SCADA.

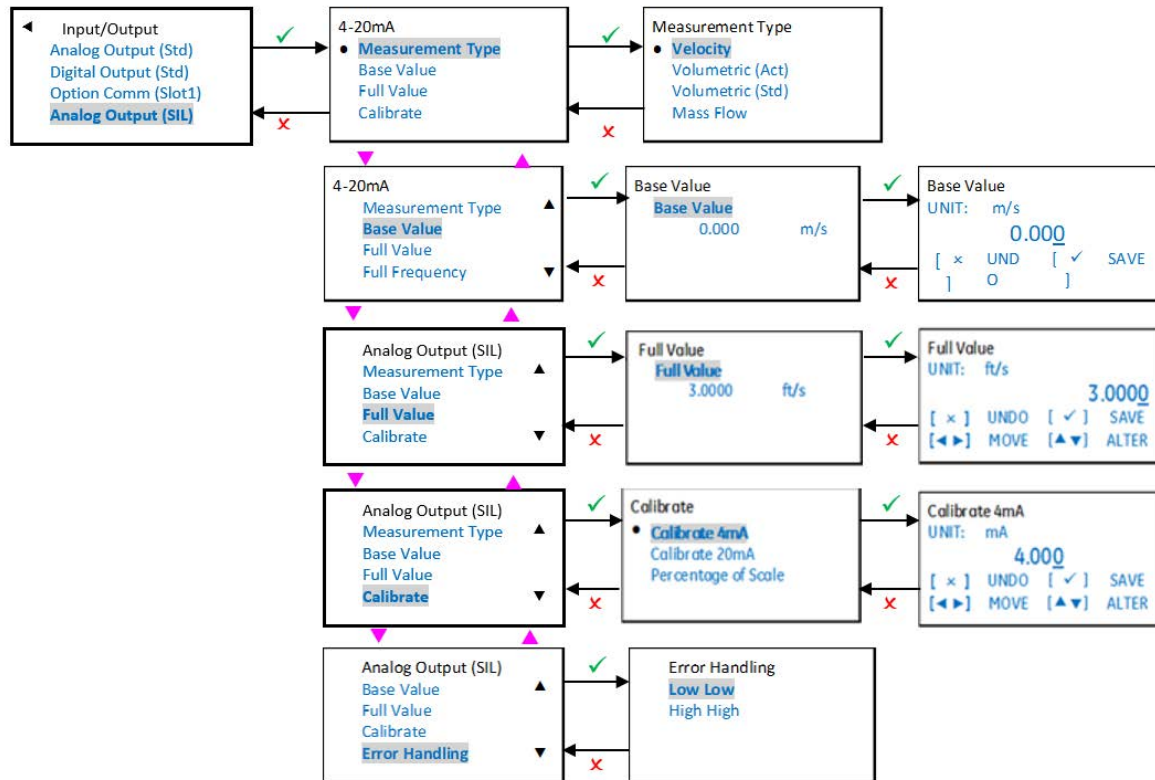

Figure 42: Analog Output (SIL)

1. Turn ON the multimeter (if used), and set it to measure Current (mA) DC.
2. Connect test lead from positive side (Aout+) of the Main Analog Output to the positive terminal of multimeter, and the negative lead to the negative terminal (Aout-).
3. Scroll down and select **[Calibrate]** option.
4. Select **[Calibrate 4mA]** and check if the reading on the multimeter reads 4.00mA \pm 0.01mA. If the value on the multimeter is not 4.00mA \pm 0.01mA, input the value read on the multimeter into the Calibrate 4mA value and press **[ENTER]**. Check multimeter again verify the Current reads 4.00mA within \pm 0.01mA.
5. Select **[Calibrate 20mA]** and check if the reading on the multimeter reads 20.00mA \pm 0.01mA. If the value on the multimeter is not 20.00mA \pm 0.01mA, input the value read on the multimeter into the Calibrate 20mA value and press **[ENTER]**. Check multimeter again verify the Current reads 20.00mA within \pm 0.01mA.
6. Select **[Percentage of Scale]** and adjust the scale to 0.00% and press **[ENTER]**, then verify the reading on the multimeter is 4.00mA within \pm 0.01mA. Then adjust the scale to 50.00% and press **[ENTER]**, then verify the reading on the multimeter is 12.00mA within \pm 0.01mA. Then adjust the scale to 100.00% and press **[ENTER]**, then verify the reading on the multimeter is 20.00mA within \pm 0.01mA.
7. If Steps 4, 5, and 6 were successfully completed and verified, the Analog output is successfully calibrated.

3.6 Main Program – Programming (Clamp-on)

The options in the Programming Page should be selected to best suit your application. The configurations selected in programming page are critical for accurate flow measurements. Incorrect programming settings can give erroneous measurements and impact accuracy.

Note: Consult the factory or Panametrics Services, if you are unsure of the appropriate settings for your application.

Note: Please use this section, if you are installing a clamp-on ultrasonic flow meter. Once complete, please move onto "Calibration" on page 62. If you are using a wetted ultrasonic flow meter, please go to "Main Program - Programming (Wetted)" on page 58.

3.6.1 Programming the Pipe

The Pipe menu allows the user to specify all pipe parameters that are required to ensure accurate ultrasonic flow rate measurements. Use steps as in section "Log-in and Primary Pages" to navigate to the Programming page.

1. Highlight **[Composite]** and press **[ENTER]**. Then Select **[Pipe]** and press **[ENTER]**.
2. Pipe dimensions like **[Outer Diameter]** (OD), **[Wall Thickness]** and **[Inner Diameter]** (ID), **[Pipe Material]**, **[Lining Material]** and **[Lining Thickness]** can be programmed in this menu. The meter supports a list of standard pipe materials as in Table 17. If a standard pipe material is selected, the pipe sound speed is automatically updated. If the pipe material is not in the standard list, choose Other for pipe material. Be sure to enter the correct pipe sound speed for your specific pipe material. The meter supports a list of standard lining materials as in Table 18. If Lining is not present, choose None. If a standard lining material is selected, the lining sound speed is automatically updated. If the lining material is not in the standard list, choose Other for lining material. Be sure to enter the correct lining sound speed for your specific lining material.

Note: The measurement units used for pipe size parameters depend on the choices made in the "Selecting Units" on page 31.

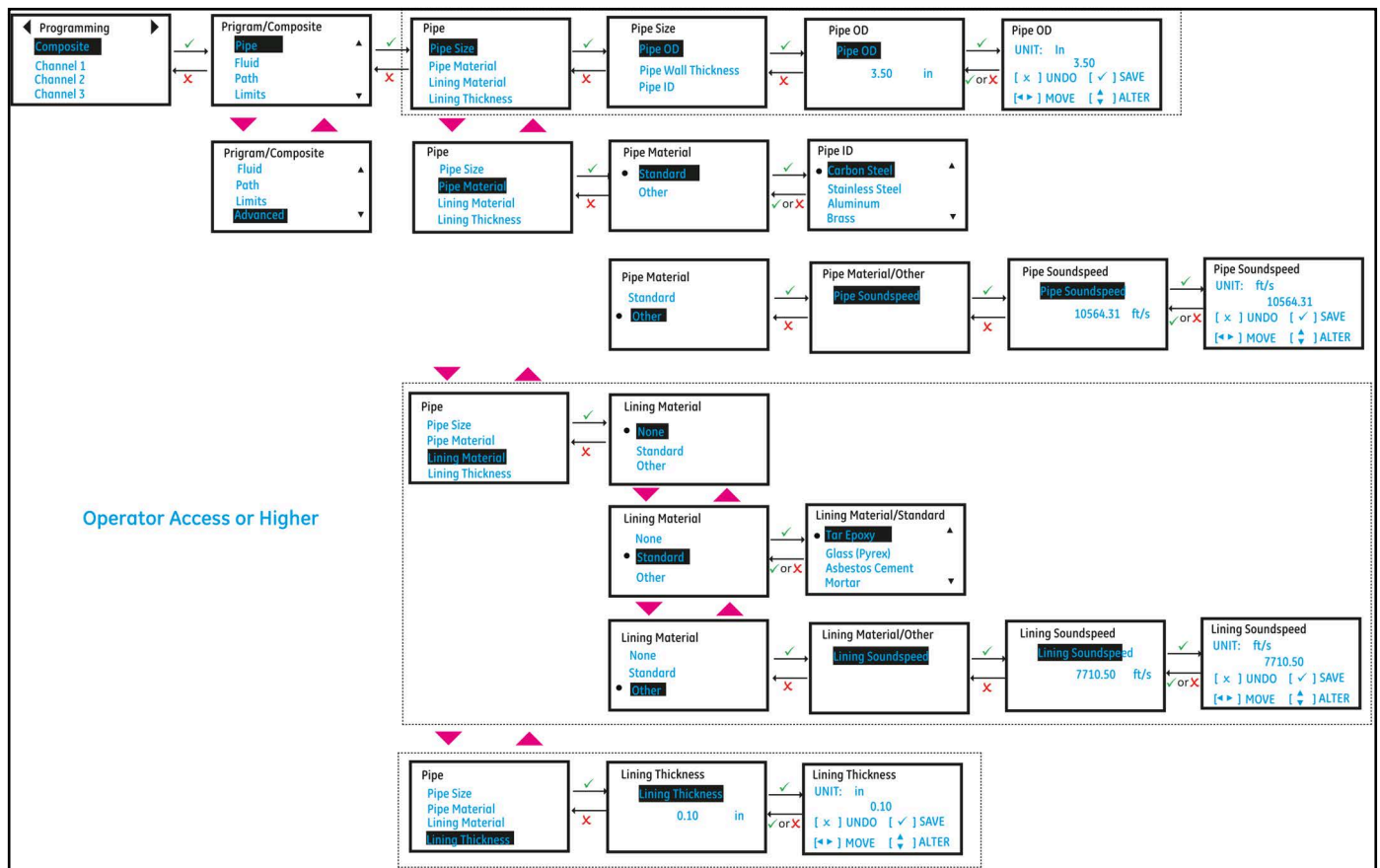

Figure 43: Pipe Programming

Table 17: Pipe Materials

Pipe Material	Description	Pipe Material	Description
Other	Any material	Iron Ductile	Ductile Iron
Carbon Steel	Carbon Steel	Iron Cast	Cast Iron
Stainless Steel	Stainless Steel	Monel	Monel
Aluminum	Aluminum	Nickel	Nickel
Brass	Brass	Plastic Nylon	Nylon
Copper	Copper	Plastic Polye	Polyethylene
Copper/Nickel 10	10% Ni/Cu alloy	Plastic Polyp	Polypropylene
Copper/Nickel 30	30% Ni/Cu alloy	Plastic PVC	Polyvinyl chloride
Glass Pyrex	Pyrex Glass	Plastic Acryl	Acrylic plastics
Glass Flint	Flint Glass	Tin	
Glass Crown	Crown Glass	Titanium	
GRP	Glass reinforced plastic	Tungsten (annealed)	
Gold	Gold	Zinc	
Inconel	Inconel		

Table 18: Lining Materials

Lining Material
Other
Tar Epoxy
Glass Pyrex
Asbestos Cement
Mortar
Rubber
Teflon

3.6.2 Programming the Fluid

The *Fluid* menu (see *Figure 44*) allows the user to specify all the parameters of the fluid flowing through the pipe that is required to ensure accurate ultrasonic flow rate measurements. Use steps as in section “Log-in and Primary Pages” to navigate to the Programming page.

1. Highlight **[Composite]** and press **[ENTER]**. Scroll down, highlight **[Fluid]** and press **[ENTER]**.
2. Highlight **[Density]**, press **[ENTER]** and program the actual density **[Density (Act)]** and reference density **[Density (Ref)]** of the process fluid.
3. Then highlight **[Kinematic Viscosity]**, press **[ENTER]** and program the kinematic viscosity of the process fluid.
4. Then highlight the **[Tracking]** option. The tracking window is used to scan through the speed of sound range programmed to detect the signal when the user is unsure of the fluid sound speed. The meter also supports a list of standard fluid types. If the process fluid is not listed in standard fluids list and if you are unsure of the fluid sound speed, set tracking window to On and program the *minimum* and *maximum* sound speed range to scan.
5. For standard fluids list (see *Table 19*) supported in the meter, the *minimum*, *maximum* and *nominal sound speeds* are automatically selected.
6. Also program the process **[Fluid Temperature]** and **[Ambient Temperature]** see *Advanced programming* section.

Table 19: Standard Fluid List

Tracking On	Tracking Off
Other	Other
Water (0 to 260 C)	Water (0 to 260C)
LNG	LNG
Oil 22C	Oil 22 C
	Sea Water
	Lube Oil
	Crude Oil
	Methanol (20 C)
	Ethanol
	Freon R12
	Diesel
	Gasoline
	Liquid Nitrogen (-199C)

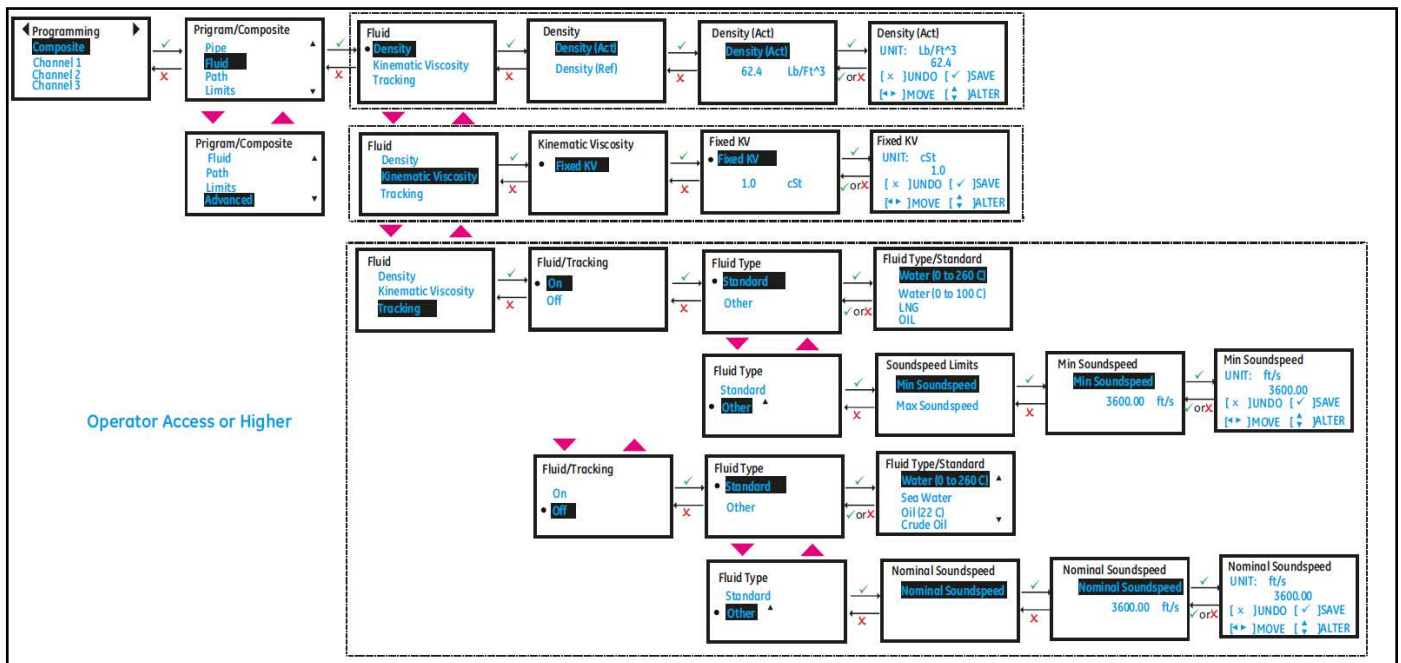

Figure 44: Fluid Programming

3.6.3 Programming the Path Configuration

Use steps as in section “Log-in and Primary Pages” to navigate to the *Programming* page. Refer to *Figure 45* for the Path configuration options.

1. Highlight **[Composite]** and press **[ENTER]**. Scroll down and select **[Path]** and press **[ENTER]**.
2. Select **[Path Configuration]**, **[Path Weights]** and **[Path Error Handling]**.
3. Path Weights are used in Composite flow velocity calculations as in the following equation:

$$Velocity_{Composite} = \frac{((Velocity_{Ch1} \times PathWeight_{Ch1}) + (Velocity_{Ch2} \times PathWeight_{Ch2}) + (Velocity_{Ch3} \times PathWeight_{Ch3}))}{(PathWeight_{Ch1} + PathWeight_{Ch2} + PathWeight_{Ch3})}$$

- If **[Path Error Handling]** is set to On, the meter will continue to provide measurements even if one or two channels are in error. Unless, all three channels (for 3 Path (TD-TD-TD)) are in error the flow measurement continues.

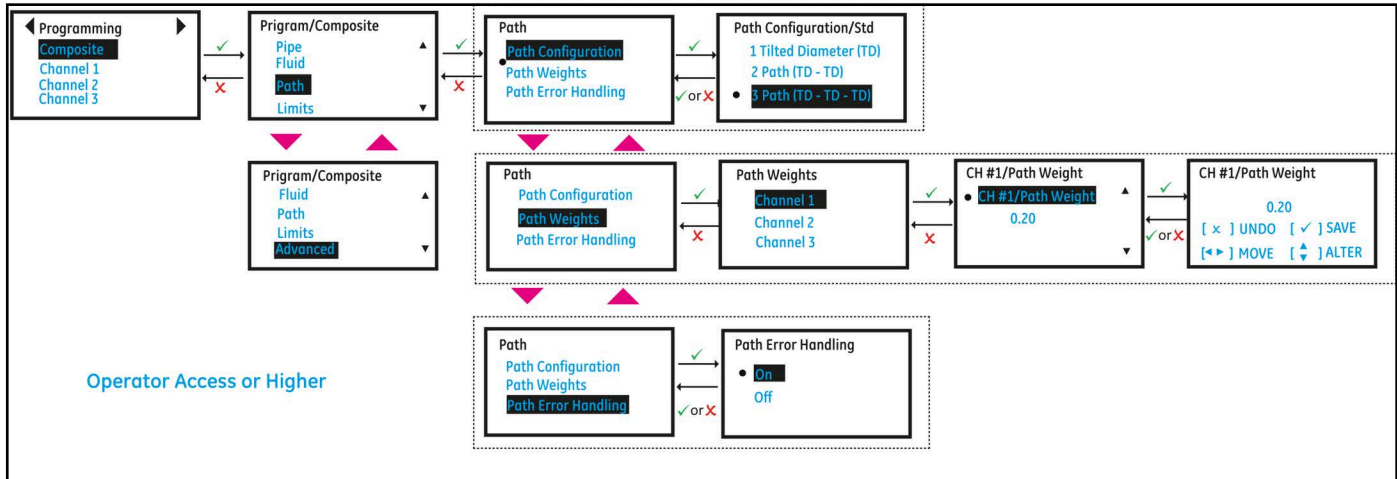

Figure 45: Path Configuration

3.6.4 Programming the Flow and Diagnostic Limits

Use steps as in section “Log-in and Primary Pages” to navigate to the *Programming* page. Refer to Figure 46 for the Path configuration options.

- Highlight **[Composite]** and press **[ENTER]**. Scroll down and select **[Limits]** and press **[ENTER]**.
- Program the minimum flow velocity in **[Min Velocity]** and maximum flow velocity in **[Max Velocity]**.
- Program the appropriate velocity warning limits in **[Min Vel Warn Limit]** and **[Max Vel Warn Limit]**. The values programmed in the warning limits should be tighter than those programmed in **[Min Velocity]** and **[Max Velocity]** for early warning indications on the LCD and Errors.
- To cutoff the near zero measurements program an appropriate value in **[Zero Cutoff]**.
 - In order to see stable averaged flow, program the time window for which flow should be averaged in **[Flow Averaging]**. For example if a value 16 is programmed in for **[Flow Averaging]**, the flow value will have the average of the last 16s of flow values. This allows the flow values on the display and the outputs to be less noisy.
- If in section “Programming the Fluid” on page 50, Tracking was selected as **OFF**, program the **[Soundspeed Error %]**. This configuration will be used to validate if the measured sound speed is within the programmed range of the nominal sound speed. In case the measured sound speed is outside the **[Soundspeed Error %]** of the nominal sound speed a E2: Soundspeed Error is reported.

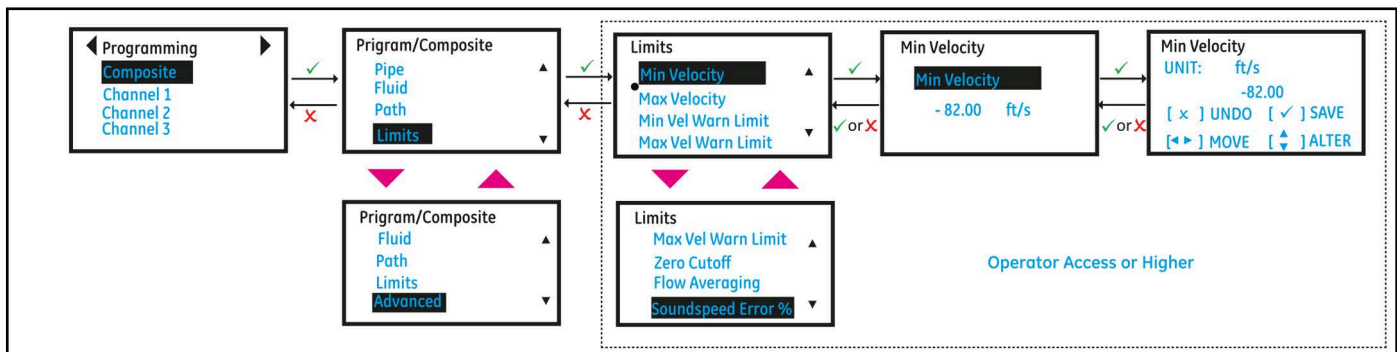

Figure 46: Flow and Diagnostic Limits

3.6.5 Programming Advanced Settings

Use steps as in section “Log-in and Primary Pages” to navigate to the *Programming page*. Refer to *Figure 47* for the Path configuration options.

1. Highlight **[Composite]** and press **[ENTER]**. Scroll down and select **[Advanced]** and press **[ENTER]**.
2. Select **[Inputs]** and set the process **[Fluid Temperature]**. The Fluid temperature can be either fixed/static (average process fluid temperature) or can be live values read from an Analog input or RTD (available as an option).
3. Also set the **[Ambient Temperature]**.
4. The **[Transmit Voltage]** should be set based on the viscosity of the process fluid and Pipe size. High viscous fluids or large pipe sizes may need high voltage setting for signals to pass through.
5. Choose the **[Refresh Rate]** based on how fast you want the meter should make a measurement. The refresh rate selection will not change the update rate on the Analog or Digital outputs. The Analog output and Digital outputs are always updated at 4Hz.

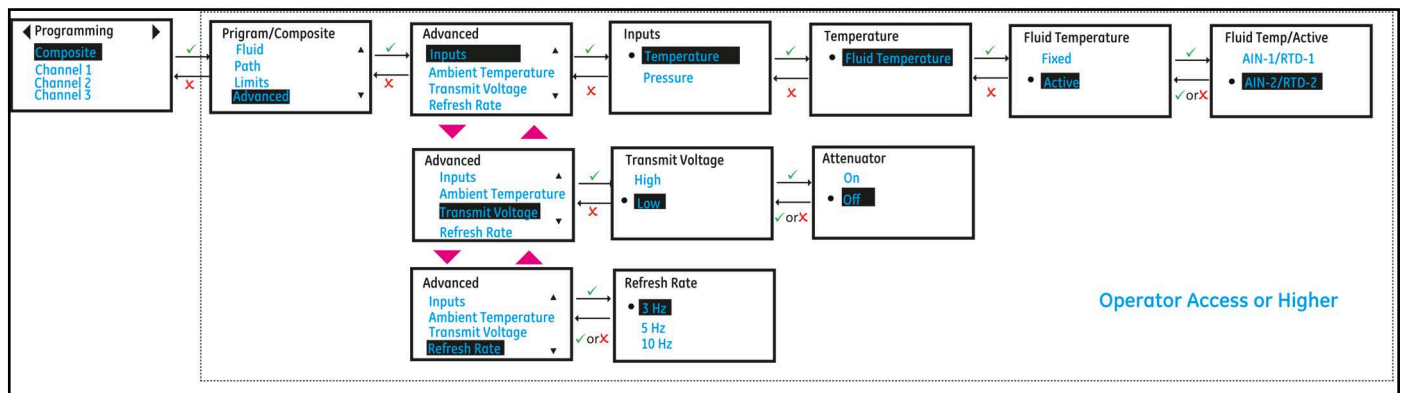

Figure 47: Advanced Setting

3.6.6 Channel X Programming

This menu is used to setup Channels' Transducers, Placement and Advanced channel settings. Use steps as in section “Log-in and Primary Pages” to navigate to the *Programming page*.

1. Then highlight **[Channel x]** and press **[ENTER]**.

3.6.6.1 Programming the Transducer

Note: The Panametrics Transducer Installation Guide for your transducer model provides more detailed information on transducer mounting configurations.

1. Scroll and highlight **[Transducer]** and press **[ENTER]**.
2. The meter supports a list of Standard transducers. For standard transducers (see *Table 20*) supported in the meter, the **[Transducer Frequency]**, **[Static Tw]**, **[Wedge Angle]** and **[Wedge Soundspeed]** are automatically selected.
3. If you have a special transducer that is not listed in *Table 20*, then select **[Transducer]** as *Special* and program the Transducer Frequency, Static Tw, Wedge Angle and Wedge Sound speed. Contact the factory or Panametrics Services for values suitable for your transducers.

Table 20: Standard Transducers

Transducer Number	Transducer Model Number
15	(#15/115) C-PT-05-H
16	(#16/116) C-PT-10-H
17	(#17/117) C-PT-20-H
23	C-LP-40-HM
24	C-LP-40-NM

Table 20: Standard Transducers

Transducer Number	Transducer Model Number
312	C-RW-312
318	C-RW-318
401	C-RS-401
402	C-RS-402
403	C-RS-403
407	UTXDR-407
408	UTXDR-408
505	C-RR-505
510	C-RR-510
520	C-RR-520
591	C-RR-591
592	C-RR-592
595	C-RR-H-595
596	C-RR-H-596
597	C-RR-H-597
601	C-AT-601
602	C-AT-602
603	C-AT-603

3.6.6.2 Programming the Placement

The **Placement** menu allows the user to configure the mounting method of the transducers, based on the Transducer and Pipe programming done as specified in sections “Main Program - Programming (Clamp-on)” on page 48 and “Programming the Transducer” on page 53

1. Refer to *Figure 50*, select **[Placement]** and press **[ENTER]**.
2. Program the **[No. of Traverses]** based on your transducer installation and transducer configuration. Refer to *Figure 48* for possible Traverse configurations supported in the meter. Typically, a two-traverse installation is used.
3. The **[Spacing]** shows the value calculated by the XMT1000 for the correct distance between the upstream and downstream transducers, based on your programmed transducer, fluid and pipe data. This is the physical spacing value that should be used when installing your transducer clamping fixture on the pipe (see *Figure 49*). When exiting from the **[Channel x]** menu, the meter will display a message indicating that the Physical spacing of the transducers need to be adjusted to the value calculated by the XMT1000.
4. Adjust the physical spacing to value calculated by the XMT1000.
5. Repeat section “Channel X Programming” on page 53 for all channels.
6. This completes the programming for flow measurements. All further steps involve calibrating meter for accurate velocity and sound speed measurements. Exit programming by pressing **[ESC]** until Save options are displayed on the menu. Highlight **[Save]** or **[Save & Logout]** and Press **[ENTER]** to save settings. The meter will not use the changed setting to make measurements until the settings are explicitly saved.
7. Make sure your pipe is full and there is no flow. Before you proceed to next section “Programming Advanced Channel Settings” on page 56, allow for a 5-minute zero flow stabilization time.

Note: If your transducers need to be installed with a spacing different than that calculated by the XMT1000, make sure it is within 10% of the calculated value. Overwrite the meter calculated [Spacing] value with installed Physical spacing.

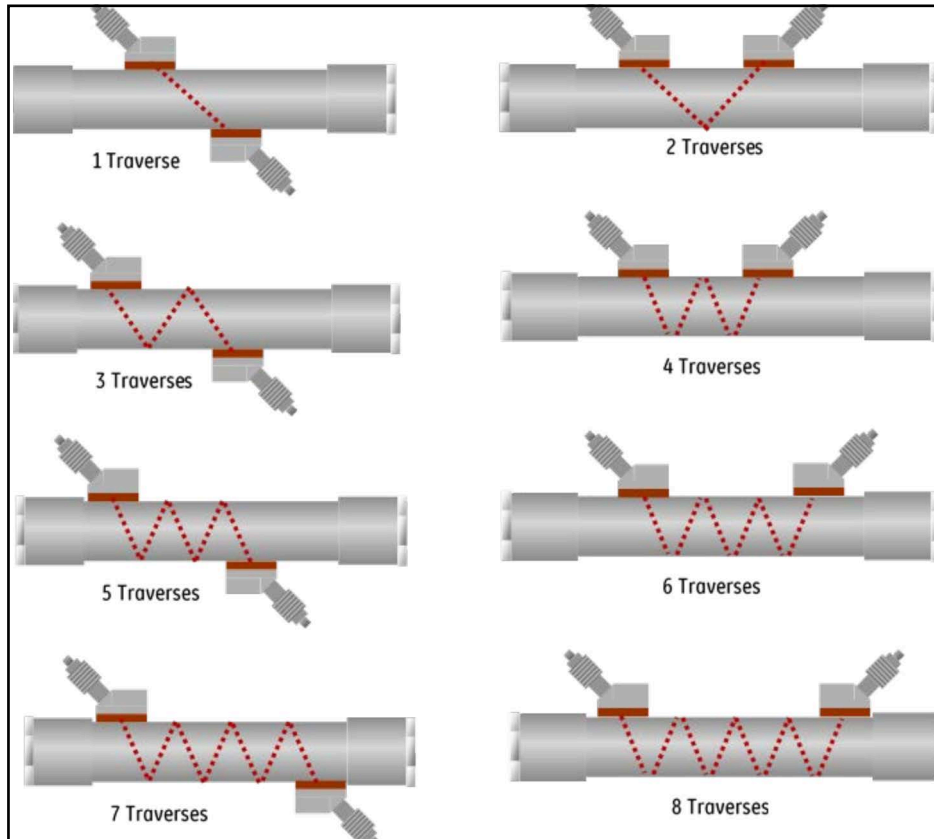

Figure 48: Traverse Configurations

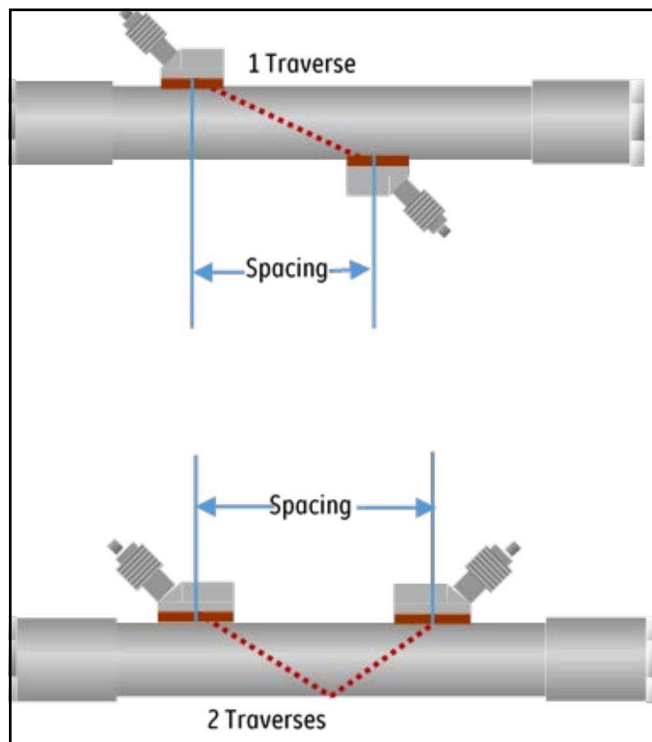

Figure 49: Spacing

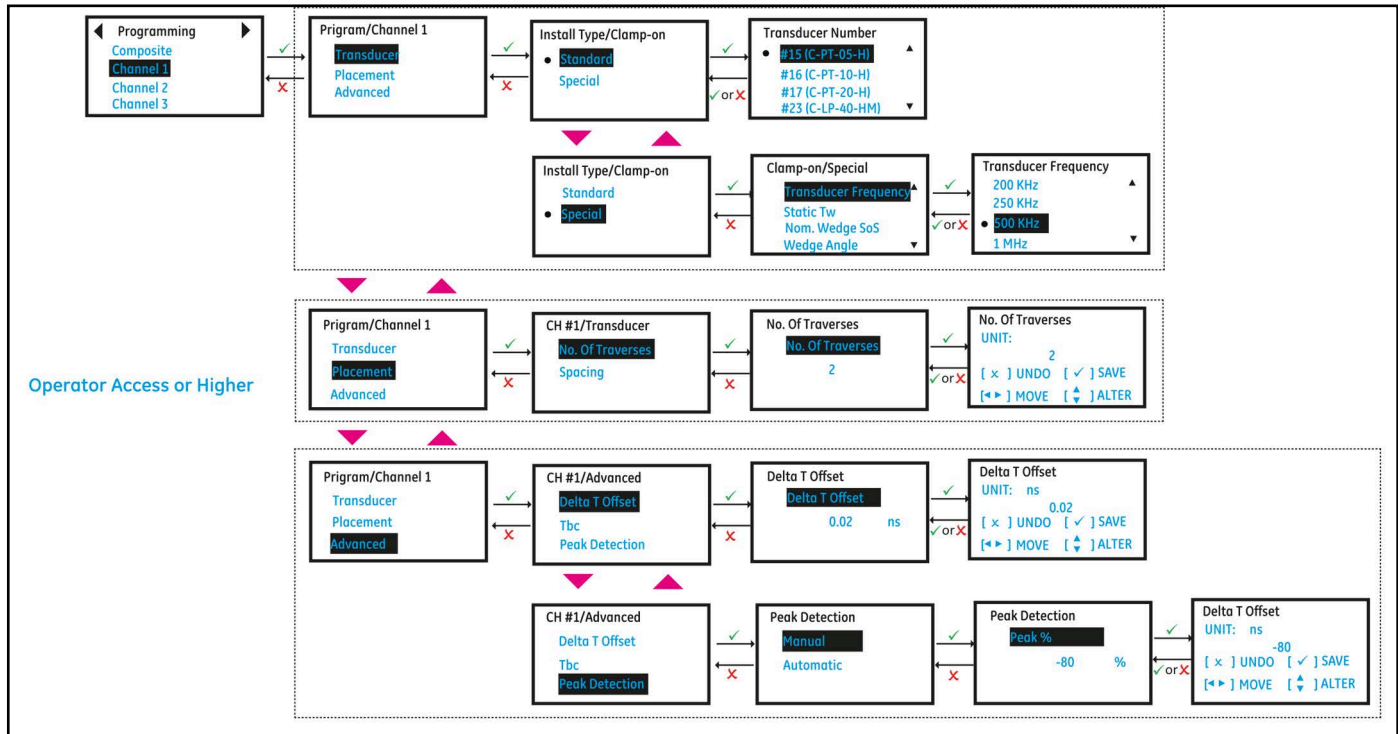

Figure 50: Channel Programming (Transducer, Placement and Advanced)

3.6.6.3 Programming Advanced Channel Settings

1. Refer to Clamp-on Calibration procedure for calibrating zero flow [**Delta-T Offset**].
2. Refer to Section 3.6.7.1 Fluid Speed of Sound Calibration for Calibrating sound speed.
3. Scroll and highlight [**Peak Detection**] and press [ENTER]. Select [**Automatic**] for the meter to automatically pick the [**Peak %**]. If you frequently see E6: Cycle Skip errors, please contact Factory.

3.6.7 Fluid Speed of Sound Calibration

In order to perform Speed of sound (SOS) calibration it's necessary to install PanaView™ Plus PC Software application version 1.2.0 or later. SOS calibration procedure is described in the CAL-TRIM-TEST section of PanaView™ Plus Help manual which can be launched from application's main menu.

The XMT1000 can calibrate the fluid speed of sound (SOS) after installation, provided the operator knows the fluid SOS under the current flow conditions. The measured fluid SOS should be within the accuracy specification after following the standard installation procedures. This SOS calibration is for fine-tuning of the XMT1000 meter under the on-site installation conditions and maintaining the high accuracy performance.

3.6.7.1 Fluid SOS calibration procedure

SOS calibration will be done on each channel. After calibration, the measured SOS from each channel, and the composite channel, shall read within ± 1 ft/s (or 0.3 m/s) of expected value. Calibrate the fluid SOS as per below procedure.

Calibration Procedure:

1. Open Panametrics PanaView™ Plus. Click on [**Connect**].
2. Select instrument model and communication Port.

Connect to Meter

Instrument Model *
XMT1000

Connection Type *
Serial RS-485

Communication Port *
COM1

Node Id *
1

Baud Rate *
115200

Parity *
Even

Data Bits *
8

Stop Bits *
1

Language *
English

Connect

Figure 51: PanaView™ Plus screen

3. Click on **[CONNECT TO INSTRUMENT]**.
4. Change **[Access Level]** to Operator and enter respective **[Password]**. Click on **[Change Access Level]**.

New Connection

Access Level
Operator

Password

Change Access Level

[Change Password](#)

Disconnect

Figure 52: PanaView™ Plus screen - Access Level

5. Click on **[Cal-Trim-Test]**. Expand the **[SOS calibration]** parameter.

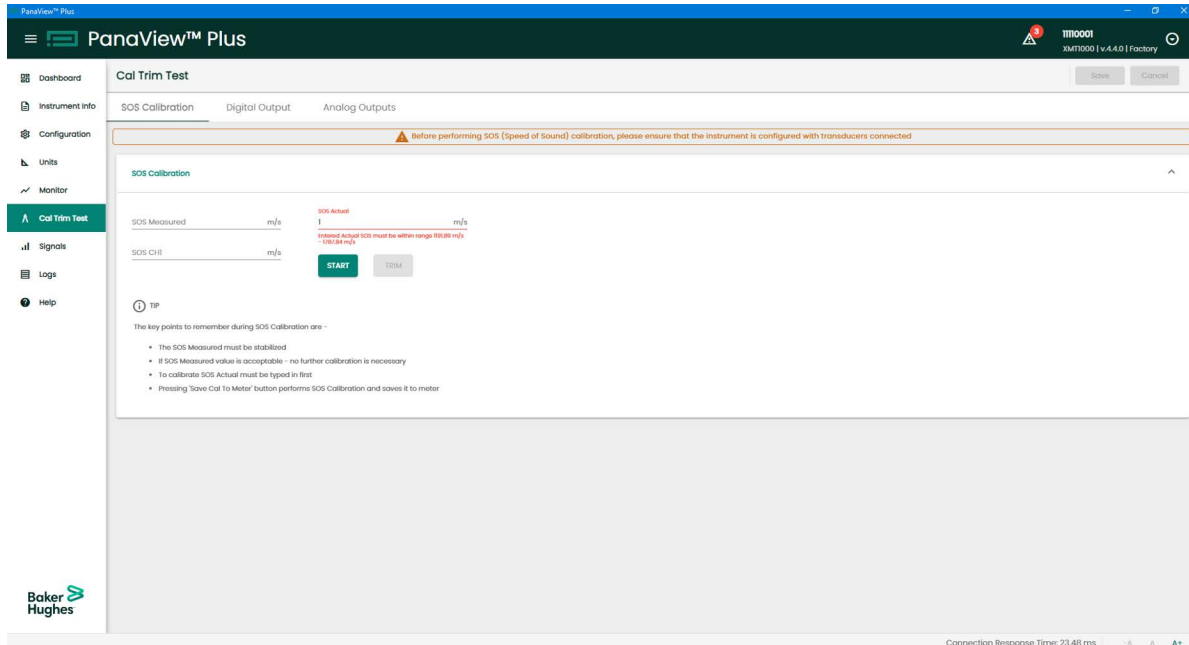

Figure 53: SOS calibrations

Depending on the path configuration, the SOS values for **SOS Measured** (composite), SOS Ch1, SOS Ch2, SOS Ch3 will be displayed and dynamically updated.

6. Enter the expected SOS value for your specific flow conditions in **[SOS Actual]** to fine-tune the meter for all its channels.
7. Click on Trim button to trim the values added in **[SOS Actual]**
8. Click on **[Save CAL TO METER]**, the displayed SOS values shall be updated accordingly.
9. Acceptance Criteria: ± 1 ft/s or 0.3 m/s.

3.7 Main Program – Programming (Wetted)

The options in the Programming Page should be selected to best suit your application. The configurations selected in programming page are critical for accurate flow measurements. Incorrect programming settings can give erroneous measurements and impact accuracy.

Note: Consult the factory or Baker Hughes Services if you are unsure of the appropriate settings for your application.

IMPORTANT: The configurations in the Programming page are pre-selected to best suit your applications. Consult the factory or Baker Hughes Services before changing any of these settings. Modifying any of the settings can give erroneous measurements and impact accuracy.

3.7.1 Programming the Pipe

The Pipe menu allows the user to specify all pipe parameters that are required to ensure accurate ultrasonic flow rate measurements. Use steps as in “Log-in and Primary Pages” on page 30 to navigate to the Programming page.

1. Highlight **[Composite]** and press **[ENTER]**. Then Select **[Pipe]** and press **[ENTER]**.
2. Pipe dimensions like **[Outer Diameter]** (OD), **[Wall Thickness]** and **[Inner Diameter]** (ID) can be programmed in this menu.

Note: The measurement units used for pipe size parameters depend on the choices made in the “Selecting Units” on page 31.

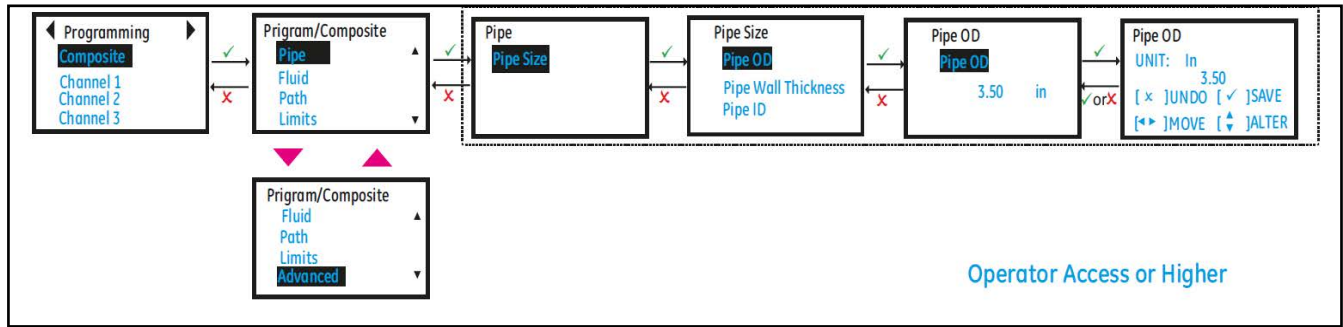

Figure 54: Pipe Programming

3.7.2 Programming the Fluid

The Fluid menu (see Figure 55) allows the user to specify all the parameters of the fluid flowing through the pipe that is required to ensure accurate ultrasonic flow rate measurements. Use steps as in “Log-in and Primary Pages” on page 30 to navigate to the Programming page.

1. Select **[Composite]** and press **[ENTER]**. Scroll down, select **[Fluid]** and press **[ENTER]**.
2. Select **[Density]**, press **[ENTER]** and program the actual density **[Density (Act)]** and reference density **[Density (Ref)]** of the process fluid.
3. Then select **[Kinematic Viscosity]**, press **[ENTER]** and program the kinematic viscosity of the process fluid.
4. Then select **[Tracking]** option. The tracking window is used to scan through the speed of sound range programmed to detect the signal when the user is unsure of the fluid sound speed. The meter also supports a list of standard fluid types. If the process fluid is not listed in standard fluids list and if you are unsure of the fluid sound speed, set tracking window to On and program the minimum and maximum sound speed range to scan. Tracking window should be set to On.
5. For standard fluids list (see Table 15) supported in the meter, the minimum, maximum and nominal sound speeds are automatically selected.
6. Also program the process **[Fluid Temperature]** and **[Ambient Temperature]** see “Programming Advanced Settings” on page 61.

IMPORTANT: Consult the factory before setting Tracking Window to Off.

Table 21: Standard Fluid List

Tracking ON	Tracking OFF
Other	Other
Water (0 to 260°C)	Water (0 to 260°C)
LNG	LNG
Oil 22°C	Oil 22°C
	Sea Water
	Lube Oil
	Crude Oil
	Methanol (20°C)
	Ethanol
	Freon R12
	Diesel
	Gasoline
	Liquid Nitrogen (-199°C)

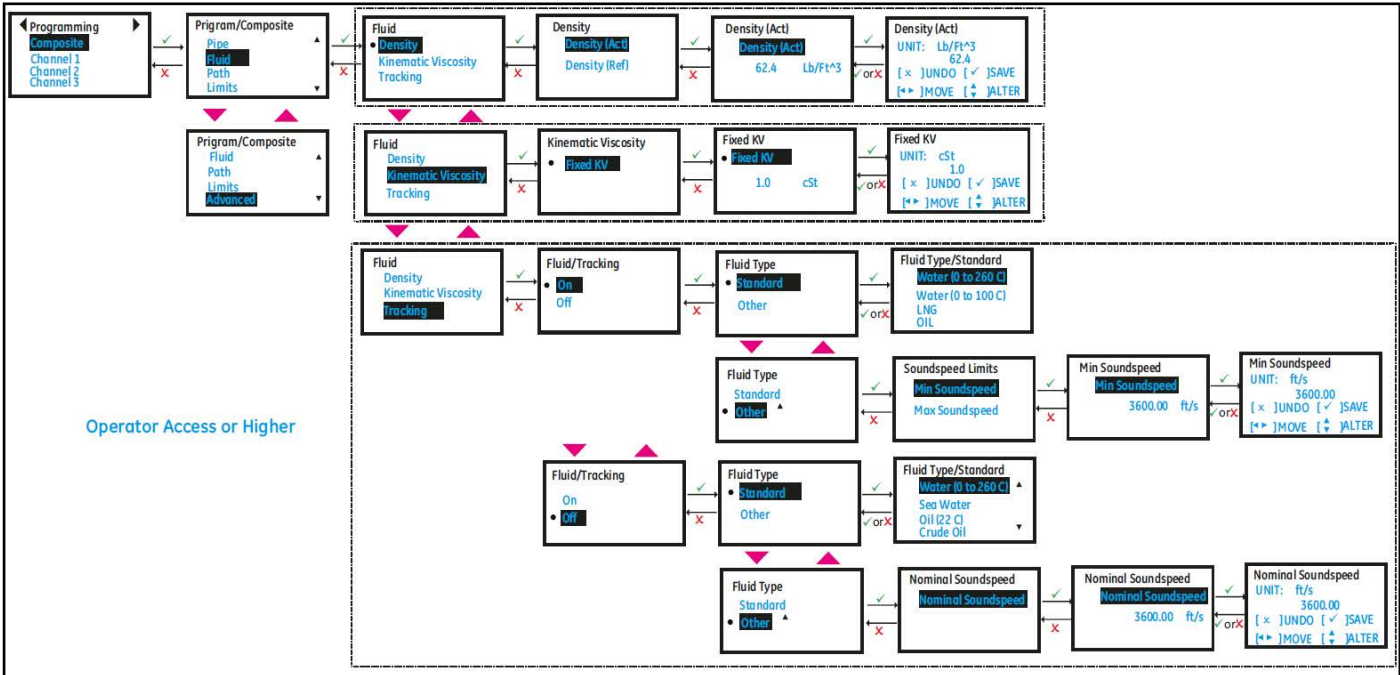

Figure 55: Fluid Programming

3.7.3 Programming the Path Configuration

Use steps as in “Log-in and Primary Pages” on page 30 to navigate to the Programming page. Refer to Figure 56 for the Path configuration options.

1. Select **[Composite]** and press **[ENTER]**. Scroll down and select **[Path]** and press **[ENTER]**.
2. Select **[Path Configuration]**, **[Path Weights]** and **[Path Error Handling]**.
3. Path Weights are used in Composite flow velocity calculations as in the following equation:

$$Velocity_{Composite} = \frac{((Velocity_{Ch1} \times PathWeight_{Ch1}) + (Velocity_{Ch2} \times PathWeight_{Ch2}) + (Velocity_{Ch3} \times PathWeight_{Ch3}))}{(PathWeight_{Ch1} + PathWeight_{Ch2} + PathWeight_{Ch3})}$$

4. If Path Error Handling is set to On, the meter will continue to provide measurements even if one or two channels are in error. Unless, all three channels are in error the flow measurement continues.

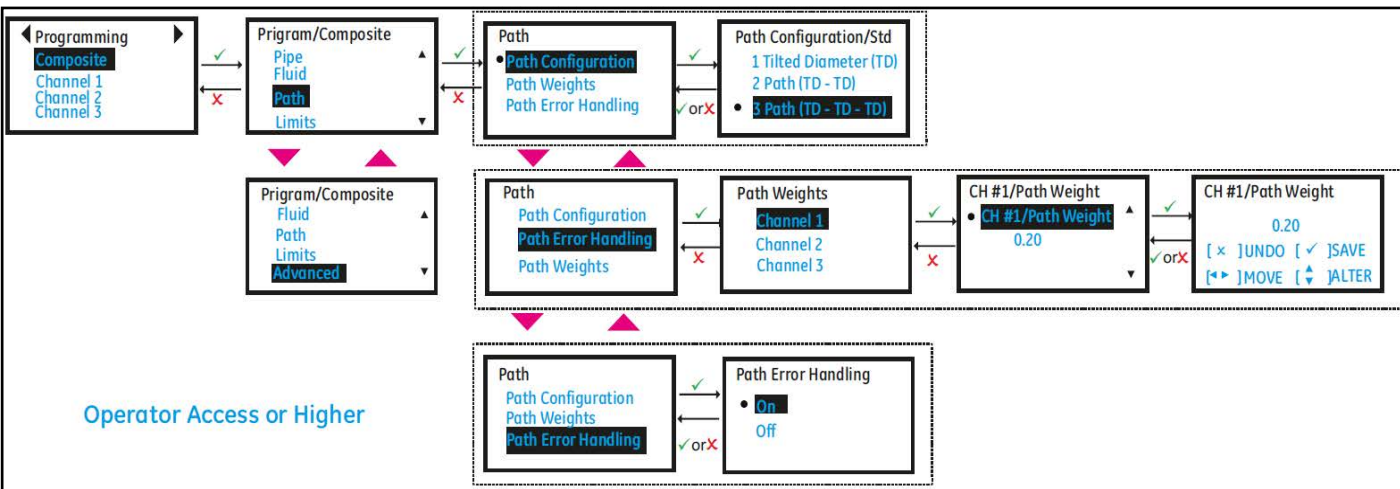

Figure 56: Path Configuration

3.7.4 Programming the Flow and Diagnostic Limits

Use steps as in “Log-in and Primary Pages” on page 30 to navigate to the Programming page. Refer to Figure 57 for the Limit selection options.

1. Select **[Composite]** and press **[ENTER]**. Scroll down and select **[Limits]** and press **[ENTER]**.
2. Program the minimum flow velocity in **[Min Velocity]** and maximum flow velocity in **[Max Velocity]**.
3. Program the appropriate velocity warning limits in **[Min Vel Warn Limit]** and **[Max Vel Warn Limit]**. The values programmed in the warning limits should be tighter than those programmed in **[Min Velocity]** and **[Max Velocity]** for early warning indications on the LCD and Errors.
4. To cutoff the near zero measurements program an appropriate value in [Zero Cutoff].
 - In order to see stable averaged flow, program the time window for which flow should be averaged in **[Flow Averaging]**. For example if a value 16 is programmed in for **[Flow Averaging]**, the flow value will have the average of the last 16s of flow values. This allows the flow values on the display and the outputs to be less noisy.
5. If in section “Programming the Fluid” on page 59, Tracking was selected as OFF, program the **[Soundspeed Error %]**. This configuration will be used to validate if the measured sound speed is within the programmed range of the nominal sound speed. In case the measured sound speed is outside the **[Soundspeed Error %]** of the nominal sound speed a E2: Soundspeed Error is reported.

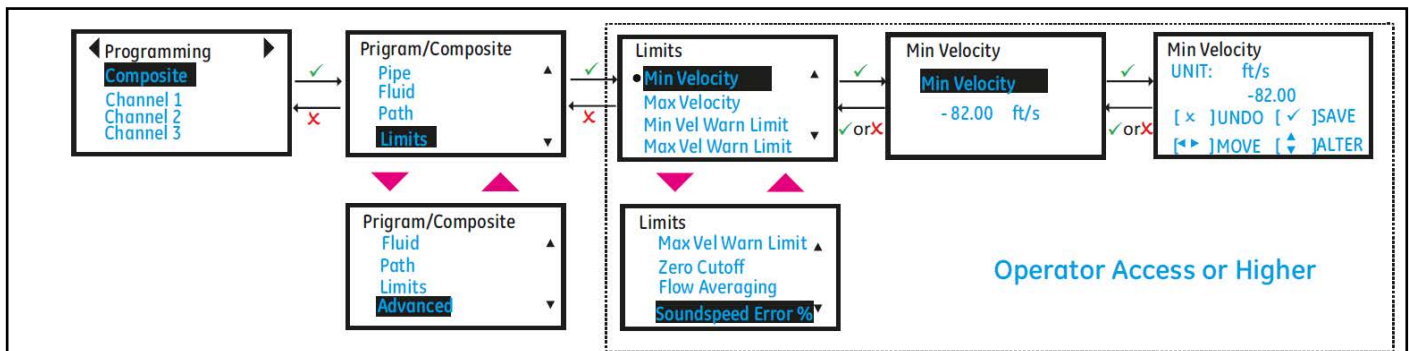

Figure 57: Flow and Diagnostic Units

3.7.5 Programming Advanced Settings

Use steps as in “Log-in and Primary Pages” on page 30 to navigate to the Programming page. Refer to Figure 58 for the Path configuration options.

1. Select **[Composite]** and press **[ENTER]**. Scroll down and select **[Advanced]** and press **[ENTER]**.
2. Select **[Inputs]** and set the process **[Fluid Temperature]**. The Fluid temperature can be either fixed/static (average process fluid temperature) or can be live values read from an Analog input or RTD (available as an option).
3. Also set the **[Ambient Temperature]**.
4. The **[Transmit Voltage]** should be set based on the viscosity of the process fluid and Pipe size. High viscous fluids or large pipe sizes may need high voltage setting for signals to pass through.
5. Choose the **[Refresh Rate]** based on how fast you want the meter should make a measurement. The refresh rate selection will not change the update rate on the Analog or Digital outputs. The Analog output and Digital outputs are always updated at 4Hz.
6. This completes the basic programming options that may need to be updated based on flow application. Advanced programming is already done at Baker Hughes Factory and during commissioning. Exit programming by pressing **[ESC]** until Save options are displayed on the menu. Highlight **[Save]** or **[Save & Logout]** and Press **[ENTER]** to save settings. The meter will not use the changed setting to make measurements until the settings are explicitly saved.

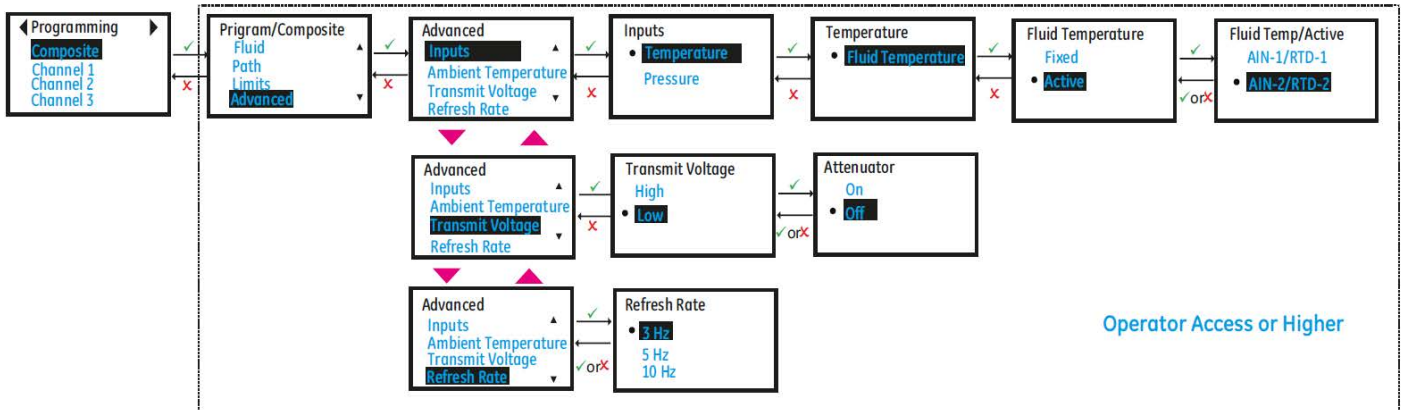

Figure 58: Advanced Settings

3.8 Calibration

This menu is used to Calibrate the XMT1000 meter to another flow rate reference. Use steps as in section “Log-in and Primary Pages” to navigate to the *Calibration page*.

Note: Use either [Meter Factor] or [K-Table], do not use both at the same time.

1. Scroll and highlight **[Meter Factor]** and press **[ENTER]**. Meter Factor is a single multiplier that is applied to the Composite Velocity measurement. The default value is 1.0 and if a single factor would suffice to bring the velocity range measured towards another flow rate reference, this option is used. If a single factor is insufficient to cover the flow velocity range or viscosity range use K-Table option.
2. If using **[Meter Factor]**, skip the following steps, otherwise Scroll and highlight **[Calibration Mode]** and press **[ENTER]**. The meter supports Gate(Totalizer) or Frequency Output Calibration methods.
 - a. If Gate(Totalizer) is chosen, connect the Gate inputs to E1 and E2 test points found on the bottom left front side of the main PCB once the front cover is removed.
 - b. If Frequency Output is used for calibration, set the **[Measurement Type]**, its corresponding **[Base Value]**, **[Full Value]**, and respective **[Base Frequency]**, **[Full Frequency]**. Set a **[Test Frequency]** value to test the Frequency Output connection before starting Calibration.
3. Scroll and highlight **[Calibration Type]** and press **[ENTER]**. The calibration type can be set to either Velocity or Reynolds number. Depending on the selection the K-Table points will be updated to accept Velocity or Reynolds number entries.
4. Scroll and highlight **[Reset K-Table]** and press **[ENTER]**. Select the table to reset. You can choose to reset all tables, or composite K-Table or any specific channel K-Table.
5. Scroll and highlight **[K-Table Selection]** and press **[ENTER]**. The default option is Off. For “as found” calibration leave the **[K-Table Selection]** as *OFF*. After completion of the “as found” calibration and identifying the K-Factor values for each calibration point, select **[Composite]** table or **[Channel]** table option.
6. Scroll and highlight **[No. of Points]** and press **[ENTER]**. Enter the number of points to enter in the K-Table.
7. Scroll and highlight **[K-Table]** and press **[ENTER]**. Select each point and update the **[Velocity]** or **[Reynolds Number]** and its corresponding **[K-Factor]**. These points define a calibration curve for the XMT1000.

Note: [K-Table] Velocity or Reynolds number (Point #1 to Point #20) should be entered in ascending order for the meter to function correctly.

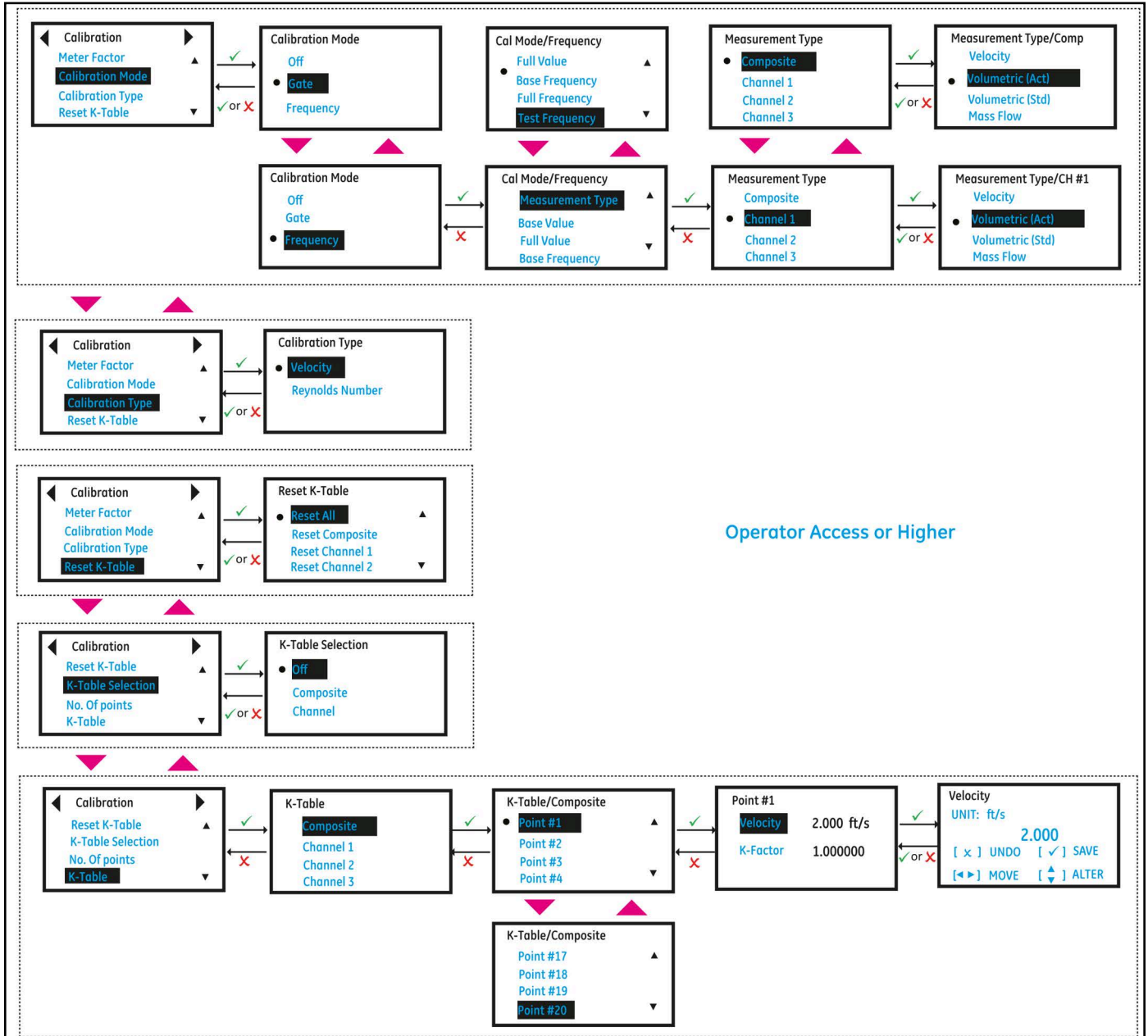

Figure 59: Calibration Menu

[no content intended for this page]

Chapter 4. Error Codes and Troubleshooting

4.1 Introduction

The XMT1000 flow transmitter is a reliable, easy to maintain instrument. When properly installed and operated, as described in Chapter: Installation, the meter provides accurate flow rate measurements with minimal user intervention. However, if a problem should arise with the electronics enclosure or transducers, this chapter explains how to troubleshoot the XMT1000 flow meter. Indications of a possible problem include:

- Display of an error message on the LCD screen, PanaView™ Plus PC software, or HART
- Erratic flow readings
- Readings of doubtful accuracy (e.g., readings that are not consistent with readings from another flow measuring device connected to the same process).

If any of the above conditions occur, proceed with the instructions presented in this chapter.

Note: For high electrical noise areas, it is recommended that you use the "CE Marking Compliance" section on page 5.

4.2 Error Classification and Error Codes

The XMT1000 electronics includes two or more subsystems. The Transmitter, Flow Measurement unit and/or Option I/O. The purpose of the Error codes and string is to convey to the operator about the issues in the specific subsystem. The communication error indicates that the Transmitter subsystem has lost communication with Flow measurement sub-system or the Option I/O sub-system.

Errors in XMT1000 are classified into 5 types as indicated in the table below:

Table 22: XMT1000 error classification

Error Classification	Error Number	Subsystem
Flow Errors	E_n where n is the Error number	Flow subsystem
System Errors	S_n where n is the Error number	Transmitter or Flow subsystem
Communication Errors	C_n where n is the Error number	Transmitter to Flow or Option I/O
Transmitter Errors	X_n where n is the Error number	Transmitter subsystem
Option I/O Errors	A_n where n is the Error number	Option I/O subsystem

If a problem occurs with the electronics or transducers, a built-in error code message system greatly simplifies the troubleshooting process.

All the possible XMT1000 error code messages are discussed in this chapter, along with the possible causes and the recommended actions. When an error code is generated, it will appear in the lower left corner of the LCD screen, as discussed in Chapter 3, Programming.

If an error message appears on the display screen during operation of the XMT1000, refer to the appropriate section of this chapter for instructions on how to proceed. You may be asked to contact Panametrics. Providing all of the diagnostic data and parameter information as in the *Diagnostics Data Table* prior to calling your local sales or service center will help to speed up the issue resolution.

In addition to the local display, error messages are provided in the relevant Modbus register using bit-field representation. For the location of the appropriate register, see *Appendix C, "Error code bit-field representation"*.

4.3 Flow Errors (E-Errors)

4.3.1 General Guidelines for Troubleshooting Flow Errors with Error codes

If the Error code on the LCD or PanaView™ Plus PC software indicate E22: SingleChAccuracy or E23: MultiChAccuracy, refer to the appropriate section below. Also, refer to *Table 23* below for causes and recommended actions for each Error code.

4.3.1.1 Single Channel Error

If only one channel is in error, the most likely causes are:

1. Incorrect programming on Error Limits or flow condition changes that now make previous programming invalid.
2. Defective/Damaged cables, transducers, incorrect physical spacing, couplant, buffer or electronics.

After you have tried eliminating/correcting for any most likely causes mentioned above, if error still exists, also check Process/flow conditions such as:

1. Excessive turbulence.
2. Discontinuities in fluid characteristics such as multi-phase flow, flashing, pockets of gas, presence of bubbles or solid particles, cavitation or rapidly changing fluid type.
3. Extreme fluid properties, such as pressure or temperature.
4. Wax build-up inside the pipe.
5. Half-full pipe.

4.3.1.2 Multi-Channel Error

If more than one channel is in error, the most likely cause is changes in process/flow conditions such as:

1. Excessive turbulence.
2. Discontinuities in fluid characteristics such as multi-phase flow, flashing, pockets of gas, presence of bubbles or solid particles, cavitation or rapidly changing fluid type.
3. Extreme fluid properties, such as pressure or temperature.
4. Wax build-up inside the pipe.
5. Partially filled pipe.

After you have tried eliminating/correcting for any most likely causes mentioned above, if error still exists, also check:

1. Incorrect programming on Error Limits or flow condition changes that now make previous programming invalid.
2. Defective/Damaged cables, transducers, incorrect physical spacing, couplant, buffer or electronics.

In case you are unable to clear the errors, collect diagnostic data and parameter information for each channel in the *Diagnostics Data Table* prior to calling your local sales or service center.

4.3.1.3 Viewing Channel Specific Error/Warnings

To indicate the health of the meter, XMT1000 has built-in Error codes. The Channel specific errors are very critical in determining the corrective actions required. *Figure 60* below shows the steps to view current channel specific errors/warnings. The description of the Error Codes and the recommended actions are provided in *Table 23* below.

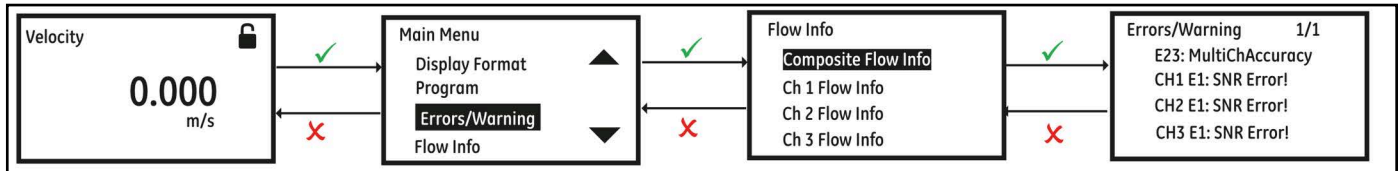

Figure 60: Viewing Current Channel Specific Errors

Table 23: Flow Error description and Recommended Actions

Error Code	Problem	Cause	Recommended Action
E1: SNR	The Signal to Noise ratio is low	The acoustic signal from the process is very weak. This could be due to bubbles, other fluid conditions, an empty pipe, broken cables, transducers, couplant or buffers	Check if the Active Tw measurement on upstream and downstream transducers is valid. If Active Tw measurement is valid then this error is an indication of the problem with the process conditions. If Active Tw measurement is not valid then check the value entered in SNR Min Error Limits option (Refer to Chapter 3, Programming). Also, refer to <i>"Fluid and Pipe Problems"</i> and <i>"Transducer Problems"</i> sections to correct for any issues
E2: Soundspeed	The measured sound speed exceeds programmed limits	The error may be caused by incorrect programming, poor flow conditions or poor transducer orientation. It may also occur if signal quality is poor	Compare the measured sound speed to programmed nominal values for the process fluid and correct any programming errors. Refer to <i>"Fluid and Pipe Problems"</i> and <i>"Transducer Problems"</i> sections to correct for any issues. In case you are unable to clear the errors, gather the required diagnostics before contacting Panametrics
E3: Velocity Range	The measured velocity exceeds programmed limits	This error may be caused by incorrect programming, poor flow conditions and/or excessive turbulence	Make sure the actual flow rate is within the programmed Error limits (Refer to Programming Chapter). Refer to <i>"Fluid and Pipe Problems"</i> and <i>"Transducer Problems"</i> sections to correct any issues
E4: Signal Quality	The signal quality is lower than the programmed limits	This means the signal shape, upstream to downstream reciprocity, or signal correlation value has fallen below the correlation peak limit. The cause is usually the same as E6 or E5	Make sure the Signal Quality is greater than the programmed Error limits (Refer to Programming Chapter). Refer to <i>"Fluid and Pipe Problems"</i> and <i>"Transducer Problems"</i> sections to correct any issues. Gather required diagnostics data before contacting Panametrics
E5: Amplitude	The signal amplitude exceeds the programmed limits	This error may occur due to high signal attenuation or amplification due to changes in fluid properties, transducer, buffer and/or couplant issues	Make sure the amplitude is within the programmed limits. If the gain is negative and Amplitude > 32, change the Transmit Voltage to <i>"Low"</i> . If it is still negative, enable Attenuator. Do not enable Attenuator if the Transmit Voltage is high. If the gain is greater than 35 dB, change the Transmit Voltage to <i>"High"</i> (Refer to Programming Chapter). Refer to <i>"Fluid and Pipe Problems"</i> and <i>"Transducer Problems"</i> sections to correct any issues. Gather required diagnostics data before contacting Panametrics

Table 23: Flow Error description and Recommended Actions

Error Code	Problem	Cause	Recommended Action
E6: Cycle Skip	A cycle skip is detected while processing the signal for measurement	This is usually due to poor signal integrity, possibly because of bubbles in the pipeline, sound absorption by very viscous fluids, or cavitation	If this error is caused by changes in flow rate, this error will be auto corrected when flow rate stabilizes after initial acceleration. But, if the error stays refer to <i>"Fluid and Pipe Problems"</i> section to correct any issues. Check Threshold Peak percentage, and gather required diagnostics data before contacting Panametrics
E15: Active Tw	The Active Tw measurement is invalid	A transducer, cable is damaged, or a transducer needs to be re-coupled. This may also be due to incorrect programming, or extreme process temperatures	Refer to <i>"Transducer Problems"</i> sections to correct any issues. In case you are unable to clear the errors, gather required diagnostics before contacting Panametrics
E22: Single Channel Accuracy	One of the measurement channels is in error	One measurement channel is in error; accuracy of the measurement may be compromised because the meter might be using a sister chord substitution	Check individual channel errors, refer to this table for recommended actions to correct channel errors
E23: Multi Channel Accuracy	Two or more measurement channels are in error	Two or more measurement channels are in error; accuracy of the measurement may be compromised because the meter is using a sister chord substitution	Check individual channel errors, refer to this table for recommended actions to correct channel errors
E27: Invalid K-Table	K-Table is invalid	The entered K-table is invalid	Check the K-table values and ensure the Velocity or Reynolds Number in the table is in ascending order
E28: Software Fault	Software malfunction	This is a Software malfunction.	This condition is not self-recovering and will not automatically correct itself. Try power cycling the meter. If error persists after power cycle, contact Panametrics factory.
E29: Velocity Warning	The measured velocity exceeds programmed warning limits	This error may be caused by incorrect programming, poor flow conditions and/or excessive turbulence	Make sure the actual flow rate is within the programmed Warning limits (Refer to Programming Chapter). Refer to <i>"Fluid and Pipe Problems"</i> and <i>"Transducer Problems"</i> sections to correct any issues
E31: Not Calibrated	The flow meter has not been calibrated	The flow meter has not been calibrated at the factory and hence not making measurements. Please contact Panametrics factory	The condition is not self-recovering and will not automatically correct itself. Contact Panametrics factory to get more information on the meter setup

4.4 Fluid and Pipe Problems

If preliminary troubleshooting with the *Error Code Messages* and the *Diagnostic Parameters* indicates a possible problem, proceed with this section. Measurement problems fall into two categories:

- Fluid problems
- Pipe problems

Read the following sections carefully to determine if the problem is related to the fluid or the pipe. If the instructions in this section fail to resolve the problem, contact Panametrics for assistance.

4.4.1 Fluid Problems

Most fluid-related problems result from a failure to observe the flow meter system installation instructions, as described in Chapter: Installation.

If the physical installation of the system meets the recommended specifications, it is possible that the fluid itself may be preventing accurate flow rate measurements. The fluid being measured must meet the following requirements:

- *The fluid must be homogeneous, single-phase, relatively clean and flowing steadily.*
Although a low level of entrained particles may have little effect on the operation of the XMT1000, excessive amounts of solid particles will absorb or disperse the ultrasound signals. This interference with the ultrasound transmissions through the fluid will cause inaccurate flow rate measurements. In addition, temperature gradients in the fluid flow may result in erratic or inaccurate flow rate readings.
- *The fluid must not cavitate near the measurement point.*
Fluids with a vapor pressure relatively close to process pressure may cavitate near the measurement point. Cavitation can usually be controlled through proper system design.
- *The fluid must not excessively attenuate ultrasound signals.*
Some fluids, particularly those that are very viscous, readily absorb ultrasound energy. In such a case, signal warning and error message will appear on the display screen to indicate that the ultrasonic signal strength is insufficient for reliable measurements.
- *The fluid soundspeed must not vary excessively.*
The XMT1000 will tolerate relatively large changes in the fluid sound speed, as may be caused by variations in fluid composition and/or temperature. However, such changes must occur slowly. Also, fluctuations in fluid sound speed due to changes in temperature will likely recover independently. Rapid fluctuations in the fluid sound speed, to a value that is beyond $\pm 20\%$ from that programmed into the XMT1000, will result in erratic or inaccurate flow rate readings. This may occur when changing batch fluids.

Note: Refer to Chapter 3: Programming, to make sure the appropriate soundspeed is programmed into the meter.

4.4.2 Pipe Problems

Pipe-related problems may result from improper choice in meter location or errors in programming. The following may result in problematic installations:

- *The collection of material at the transducer location(s).*
Accumulated debris at the transducer locations will interfere with the transmission of the ultrasound signals. As a result, accurate flow rate measurements are not possible. Realignment of the transducers often corrects these problems but, in some cases, wetted transducers must be used. Refer to *Chapter: Installation* for more details on proper installation practices.
- *Inaccurate pipe measurements.*
The flow rate measurement accuracy relies greatly on the accuracy of the programmed pipe dimensions. Measure the pipe wall thickness and diameter with the same accuracy desired in the flow rate readings. Also, check the pipe for dents, pitting or rough surfaces, eccentricity, weld deformity, straightness and other factors that may cause inaccurate readings. Refer to the *Chapter: Programming*, for instructions on entering the pipe data.
- *The inside of the pipe or pipe is not sufficiently clean.*
Excessive buildup of scale, rust or debris inside the pipe will interfere with flow measurements. Generally, a thin coating or a solid well-adhered build up on the pipe wall will not cause problems. Loose scale and thick coatings (such as tar or oil) will interfere with ultrasound transmission and may result in incorrect or unreliable flow rate measurements.

4.5 Transducer Problems

Ultrasonic transducers are rugged, reliable devices. However, they are subject to physical damage from mishandling and chemical attack. The following list of potential problems is grouped according to transducer type. Contact Panametrics if you cannot solve a transducer-related problem.

4.5.1 Transducer Problems

- **Internal Damage:** An ultrasonic transducer consists of a ceramic crystal bonded to the transducer case. The bond between the crystal and the case or the crystal itself may be damaged by extreme mechanical shock and/or temperature extremes. Also, the internal wiring can be corroded or shorted if contaminants enter the transducer housing.
- **Physical Damage:** Transducers may be physically damaged by dropping them onto a hard surface or striking them against another object. The transducer connector is the most fragile part and is most subject to damage. Minor damage may be repaired by carefully bending the connector back into shape. If the connector can not be repaired, the transducer must be replaced.

IMPORTANT: Transducers must be replaced in pairs. Refer to *Chapter 3, Programming* to enter the new transducer data into the meter.

4.6 System Errors (S-Errors)

These errors are from the Flow subsystem. The system errors have 4 types of information.

1. Indicator
2. Warning
3. Error
4. Fault

The indicator is just a notification to the operator, no action is needed. The warnings are usually indicative of an operator error. Errors indicate failures that need attention. Operator should perform recommended actions to recover from these errors. Faults are usually indicative of more serious failures related to background hardware / software integrity checks performed by XMT1000 meter. See the table below for error codes, error messages, error type and recommended actions.

Table 24: System Error Description and Recommended Actions

Error Code	Error Message	Description / Recommended Action
S1: In Config Mode	In configuration mode indicator	Indicator: This is displayed when a user has logged in to either Operator, Admin or Factory access level. The indicator will clear automatically when the user logs out or saves the configuration changes
S2: Invalid User	Invalid user warning	Warning: The passcode entered for access level is incorrect. Please log in with the correct access level and passcode
S3: Invalid Request	Invalid request warning	Warning: An invalid communication packet was received and discarded. Or, the requested operation is invalid. Please send a valid packet or operation request
S4: Invalid Param Range	Invalid parameter range warning	Warning: The value programmed for the parameter was out of range and hence discarded. Please enter a valid range
S5: Unsupported Parameter	This parameter is not supported	Warning: A read or write request to an unsupported parameter was received
S6: Flow Measurement	One or more flow measurement channels are in error	Error: One or more flow measurement channels are in error; accuracy of the measurement may be compromised. For more details please check flow(E) errors
S7: Persistent Param CRC	Persistent parameter CRC fault	Fault: Persistent parameter CRC failed. Try power cycling the meter. If error persists after power cycle, contact Panametrics factory

Table 24: System Error Description and Recommended Actions

Error Code	Error Message	Description / Recommended Action
S11: Clock Frequency	Clock frequency error	Fault: Input clock frequency failure. Try power cycling the meter. If error persists after power cycle, contact Panametrics factory
S12: CPU	CPU error	Fault: CPU registers have stuck bits. Try power cycling the meter. If error persists after power cycle, contact Panametrics factory
S13: Invariable Flash Memory	Flash memory fault	Fault: Flash memory test failed. Try power cycling the meter. If error persists after power cycle, contact Panametrics factory
S14: Invariable SRAM	Invariable SRAM fault	Fault: Invariable SRAM memory test failed. Try power cycling the meter. If error persists after power cycle, contact Panametrics factory
S15: Variable Memory	Variable SRAM fault	Fault: Variable SRAM test failed. Try power cycling the meter. If error persists after power cycle, contact Panametrics factory
S16: FPGA Config	FPGA configuration error	Fault: FPGA configuration validation failure. Try power cycling the meter. If error persists after power cycle, contact Panametrics factory
S17: Temperature	Temperature error	Error: Temperature of the electronics is outside the pre-defined operating range. Make sure that the ambient temperature is not outside the meter operating range
S18: Driver Fault	Driver failure	Fault: Driver failure. Try power cycling the meter. If error persists after power cycle, contact Panametrics factory
S19: Watch Dog Failure	Watch dog failure	Fault: Watch dog test failed. Try power cycling the meter. If error persists after power cycle, contact Panametrics factory
S21: Stack Overflow	Stack overflow	Fault: Stack overflow. Try power cycling the meter. If error persists after power cycle, contact Panametrics factory
S22: Sequence or Window Watchdog	Sequence failed	Fault: Sequence failure detected. Try power cycling the meter. If error persists after power cycle, contact Panametrics factory
S23: Initialization Failed	Initialization failed	Error: Initialization failed. Please verify all the configuration parameters. If error persists, contact Panametrics factory
S24: DSP Hardware Errors	DSP hardware failed	Fault: DSP hardware failure detected. Try power cycling the meter. If error persists after power cycle, contact Panametrics factory
S25: DSP Exception	DSP exception	Fault: DSP exception. Try power cycling the meter. If error persists after power cycle, contact Panametrics factory
S26: Default ISR	Exception within the ISR	Fault: Exception within the ISR. Try power cycling the meter. If error persists after power cycle, contact Panametrics factory
S27: DSP Reset ISR	Exception within the DSP ISR	Fault: Exception within the DSP ISR. Try power cycling the meter. If error persists after power cycle, contact Panametrics factory
S28: Software Fault	Software malfunction	Error: Software malfunction. Try power cycling the meter. If error persists after power cycle, contact Panametrics factory

Table 24: System Error Description and Recommended Actions

Error Code	Error Message	Description / Recommended Action
S29: Output A Loop Open!	SIL Analog Output Open Error	Fault: SIL Analog Output is disconnected. Connect the SIL Analog output and try power cycling the meter. If error persists after power cycle, contact Panametrics factory
S30: Flash Save Failed	Save to Flash Failed	Error: Request to Save failed. Try again. If error persists, contact Panametrics factory

4.7 Communication Errors (C-Errors)

The communication error indicates that the Transmitter subsystem has lost communication with Flow measurement sub-system or the Option I/O sub-system.

Table 25: Communication Error Description and Recommended Actions

Error Code	Error Message	Description / Recommended Action
C1: Flow COMM Error	Flow board communication error	Transmitter cannot communicate to the flow measurement unit. Try power cycling the meter. If error persists after power cycle, contact Panametrics factory
C2: MODE MISMATCH	Mode Mismatch Error	Fault: Mode Mismatch Error, Try power cycling the meter. If error persists after power cycle, contact Panametrics factory
C3: Option I/O COMM Error	Optional I/O subsystem communication error	Transmitter cannot communicate to the Optional I/O in Slot-2. Try power cycling the meter. If error persists after power cycle, contact Panametrics factory

4.8 Transmitter Errors

These errors are from the Transmitter subsystem. Should you encounter one of the Transmitter Errors, follow recommended actions as indicated in *Table 26* and contact Panametrics factory.

Table 26: Transmitter Error Description and Recommended Actions

Error Code	Error Message	Description / Recommended Action
X1: MCU RAM Error	Transmitter RAM Fail	Memory test on transmitter RAM failed. Try power cycling the meter. If error persists after power cycle, contact Panametrics factory
X2: MCU Flash CRC Error	Flash memory test failed	Flash memory test failed. Try power cycling the meter. If error persists after power cycle, contact Panametrics factory
X7: MPU not Detected	No flow board detected	Flow board is not detected by the transmitter. Try power cycling the meter. If error persists after power cycle, contact Panametrics factory
X12: System Command Fail	System command failed	System command failed. Try power cycling the meter. If error persists after power cycle, contact Panametrics factory
X13: Get GUI Node Fail	Failed to generate GUI	Failed to generate GUI. Try power cycling the meter. If error persists after power cycle, contact Panametrics factory
X14: Node Memory Fail	GUI node memory failed	GUI node memory failed. Try power cycling the meter. If error persists after power cycle, contact Panametrics factory

Table 26: Transmitter Error Description and Recommended Actions

Error Code	Error Message	Description / Recommended Action
X15: Font API Initialize Fail	Failed to generate font	Failed to generate font. Try power cycling the meter. If error persists after power cycle, contact Panametrics factory
X16: XML File Initialize Fail	XML file initialization failed	XML file initialization failed. Try power cycling the meter. If error persists after power cycle, contact Panametrics factory
X17: Disconnect Std Dout	Transmitter Error	Fault: Transmitter Error. Connect the digital input to meter. If error persists, contact Panametrics factory
X18: Aout(Std) Out Of Range	Transmitter Out Of Range Error	Fault: Transmitter Out Of Range Error, Configure analog out with in the range, If error persists, contact Panametrics factory

4.9 Option I/O Errors

Table 27: Option I/O Errors Description

Error Code	Error Message	Description
A1:AnalogCh(S2:3) Error!	ADC Channel(S2:3) is not responding	Analog input /RTD input is not working. If error persists after power cycle, contact Panametrics factory
A2:AnalogCh (S2:4) Error!	ADC Channel(S2:4) is not responding	Analog input /RTD is not working. If error persists after power cycle, contact Panametrics factory
A3:AnalogCh (S2:1) Error!	DAQ Channel (S2:1) is not responding	Analog output (4-20mA) is not working. If error persists after power cycle, contact Panametrics factory
A4:AnalogCh (S2:2) Error!	DAQ Channel (S2:2) is not responding	Analog output (4-20mA) is not working. If error persists after power cycle, contact Panametrics factory
A6:(S2:3)Ch Not Calibrated	Error occurs when Analog Input/RTD (S2:3) are not calibrated	Calibrate the Analog Input/RTD input. If error persists after calibration, contact Panametrics factory
A7:(S2:4)Ch Not Calibrated	Error occurs when Analog Input/RTD (S2:4) are not calibrated	Calibrate the Analog Input/RTD input. If error persists after calibration, contact Panametrics factory
A8: (S2:1)Ch Not Calibrated	Error occurs when Analog Input/RTD (S2:1) are not calibrated	Calibrate the Analog Input/RTD input. If error persists after calibration, contact Panametrics factory
A9: (S2:2)Ch Not Calibrated	Error occurs when Analog Input/RTD (S2:1) are not calibrated	Calibrate the Analog Input/RTD input. If error persists after calibration, contact Panametrics factory
A10:(S2:3)Input NotConnect!	Analog Input: Error occurs when (4-20mA) input is not connected at Channel (S2:3). RTD Input: Error occurs when RTD input is not connected or temp greater than 390 deg C at Channel (S2:3)	Check connectivity for Analog Input/RTD input and RTD temperature. Try power cycling the meter. If error persists after power cycle, contact Panametrics factory

Table 27: Option I/O Errors Description (cont.)

Error Code	Error Message	Description
A11:(S2:4)Input NotConnect!	Analog Input: Error occurs when (4-20mA) input is not connected at Channel (S2:4). RTD Input: Error occurs when RTD input is not connected or temp greater than 390 deg C at Channel (S2:4)	Check connectivity for Analog Input/RTD input and RTD temperature. Try power cycling the meter. If error persists after power cycle, contact Panametrics factory
A12:(S2:3)Ch OverRange Err!	Exceeds input values. For analog input (S2:3) greater than 21mA	Ensure analog input current less than 21mA. Try power cycling the meter. If error persists after power cycle, contact Panametrics factory
A13:(S2:4)Ch OverRange Err!	Analog input(S2:4) greater than 21mA	Ensure analog input current less than 21mA. Try power cycling the meter. If error persists after power cycle, contact Panametrics factory
A18:SerialNo Error!	Optional I/O Serial Number Error	Fault: Optional I/O Serial Number Error. Try power cycling the meter. If error persists after power cycle, contact Panametrics factory
A24:Aout(S2:1)OutOfRange!	When output from analog output(S2:1) exceeds 21 mA or less than 3.6 mA	Check the flow velocity. If velocity is within limits and error still persists, contact Panametrics factory
A25:Aout(S2:2)OutOfRange!	When output from analog output(S2:2) exceeds 21 mA or less than 3.6 mA	Check the flow velocity. If velocity is within limits and error still persists, contact Panametrics factory
A30:Board Option Err!	Optional I/O Error	Fault: Optional I/O Error. Try power cycling the meter. If error persists after power cycle, contact Panametrics factory
A31:(S2:3)Ch UnderRange!	Lesser input values. For analog input(S2:3) between 3.6 mA to 0.25mA	Check input analog current is between 3.6 mA to 21mA. If error persists, contact Panametrics factory
A32:(S2:4)Ch UnderRange!	Lesser input values. For analog input(S2:4) between 3.6 mA to 0.25mA.	Check input analog current is between 3.6 mA to 21mA. If error persists, contact Panametrics factory

4.10 Diagnostics Data

To determine the health of the meter, XMT1000 has built-in diagnostic parameters. Please refer to *Table 28* below for diagnosing any problems with the system. If the meter shows errors and the diagnostics data indicate issues, fill in the User/Service record appendix before contacting Panametrics factory.

Table 28: Diagnostic Parameters

Parameter	Description	Good	Bad
Sound Speed	Measured speed of sound of the fluid	<ul style="list-style-type: none"> Under ideal conditions sound speed should be within 5 ft/s (1.5 m/s) between channels. Depending on flow viscosity, flow rate, there can be slightly different sound speed showing on different channels. This could be normal due to different signal path. 	<ul style="list-style-type: none"> Under ideal conditions, sound speed spread of 30 ft/s (9 m/s) or more between the sound speed measurement of the channels can be an indication of a problem with the pipe installation or any other different local pipe condition.
SNR Up	Signal to noise ratio of the upstream transducer	>5	<2 SNR value between 2 and 5 shall provide valid measurements but can be an indication of a problem with the pipe installation or any other different local pipe condition. Verify the clamping fixture alignment, transducer spacing, transducers, couplant, all the other connections.
SNR Down	Signal to noise ratio of the downstream transducer	>5	<2 SNR value between 2 and 5 shall provide valid measurements but can be an indication of a problem with the pipe installation or any other different local pipe condition. Verify the clamping fixture alignment, transducer spacing, transducers, couplant, all the other connections.
Gain Up / Gain Down	Gain setting	>0 dB and <35 dB <ul style="list-style-type: none"> In water applications, under ideal conditions, gain should be greater than 0 dB and less than 20 dB. For higher viscous liquids, gain between 20dB and 35 dB is acceptable. 	>35 dB or <0 dB <ul style="list-style-type: none"> Gain spreads of 10dB or more between the channels can be an indication of a problem with the pipe installation or any other different local pipe condition. If the gain is negative, change the Transmit Voltage to "Low". If it is still negative, enable Attenuator. Do not enable Attenuator if the Transmit Voltage is high. If the gain is greater than 35 dB, change the Transmit Voltage to "High".

Table 28: Diagnostic Parameters (cont.)

Parameter	Description	Good	Bad
Peak Index Up	Threshold peak of the upstream transmit correlation signal	<ul style="list-style-type: none"> For pipe sizes greater than 1 inch, index should be between 400 - 700. For pipe sizes less than 1 inch, the index should be between 150 - 350. 	<ul style="list-style-type: none"> For pipe sizes greater than 1 inch, if the index <400 or >700 then there is an indication of problem with receive window location. For pipe sizes less than 1 inch, if the index <150 or >350 then there is an indication of problem with receive window location.
Peak Index Down	Threshold peak of the downstream transmit correlation signal	<ul style="list-style-type: none"> For pipe sizes greater than 1 inch, index should be between 400 - 700. For pipe sizes less than 1 inch, the index should be between 150 - 350. 	<ul style="list-style-type: none"> For pipe sizes greater than 1 inch, if the index <400 or >700 then there is an indication of problem with receive window location. For pipe sizes less than 1 inch, if the index <150 or >350 then there is an indication of problem with receive window location.
Wall Time	Transit time inside the pipe wall	N.A	If the value is negative, then there is an indication of problem with the configuration parameters.
Lining Time	Transit time inside the pipe lining	N.A	If the value is negative, then there is an indication of problem with the configuration parameters
Signal Quality Up	Signal quality of the upstream transducer	>1000	<1000
Signal Quality Down	Signal quality of the downstream transducer	>1000	<1000
Amplitude Up	Signal amplitude of the upstream transducer	>14 and <32	>32 or <14
Amplitude Down	Signal amplitude of the downstream transducer	>14 and <32	>32 or <14

Chapter 5. Maintenance and Service

Local requirements may or may not allow field replacement of any components in this flow metering system without a proper calibration of the entire system at an approved calibration facility. Check with your local Panametrics & Panametrics Flow meter representative to determine if field replacement of components is allowed.

For Functional Safety installations, it is especially important to consult the Panametrics Flow Meter representative before changing hardware components, software versions, or even some program parameter settings. Please consult XMT1000 SIL Safety Manual, section "List of Safety Parameters", for a list of program parameters and their potential impact on Functional Safety.

5.1 Spare Parts

If a fault is found with the flow meter electronics, the entire measurement head can be replaced to ensure hardware and firmware compatibility or possibly specific electronic boards. To ensure that the correct part numbers are ordered, provide your local Panametrics & Panametrics Flow meter representative with the serial number of the meter, located as shown on the Part String and Serial Number Tag Plate.

5.2 Installing Replacement Parts

If it is appropriate to replace any component of the flow metering system, the Panametrics & Panametrics Flow meter field service team is trained and equipped to perform the replacement on-site. Installation of these field replaceable parts by a Baker Hughes field service team member will maintain the accuracy of the system and any applicable warranty. Please consult Panametrics to order the appropriate components and to schedule installation in the field.

[no content intended for this page]

Appendix A. Specifications

A.1 Operation and Performance

Fluid Types

Liquids: acoustically conductive fluids, including most clean liquids, and many liquids with small amounts of entrained solids or gas bubbles.

Transducer Types

All liquid wetted and clamp-on transducers.

Pipe Sizes

Standard: 1 in. to 76 in. (25 mm to 1930 mm)

Optional: >76 in. (1930 mm) consult factory

Data Logging

Storage standard on meter, up to 10,000 flow data points with 26 parameters per data point (required PanaView™ Plus software)

Note: *Please see other operation and performance criteria with the PanaFlow HT, PanaFlow Z3, PanaFlow LZ, and PanaFlow LC flowmeter system manuals.*

Measurement Parameters

Volumetric Flow, Mass Flow, Flow Velocity and Totalized Flow

Flow Accuracy (Velocity)

Up to $\pm 0.3\%$ of reading (achievable when supplied with a complete flow meter system and process calibration). Accuracy depends on pipe size, installation and number of measurement paths.

Note: *The accuracy statement assumes measurement of a single phase homogeneous liquid with a fully developed symmetrical flow profile passing through the meter. Applications with piping arrangements that create an asymmetrical flow profile may require extended piping straight runs and/or flow conditioning for the meter to perform to this specification.*

Repeatability

$\pm 0.1\%$ to 0.3% of reading

Range (Bidirectional)

-40 to 40 ft/s (-12.2 to 12.2 m/s)

Meter Turndown

400 : 1

Optional PC Software

PanaView™ Plus software for added functionality

A.2 Electronics

Enclosures

Powder coated aluminum or stainless steel (SS316)

Classifications

XMT1000 PanaFlow Transmitter

USA/Canada - explosion-proof class I, division 1, groups B, C, and D

ATEX - Flameproof II 2 G Ex db IIC T6 Gb; Ta = -45°C to +65°C

FISCO Ex db [ia Ga] IIC T6 Gb; Ta = -45°C to +60°C

IECEx - Flameproof Ex db IIC T6 Gb; Ta = -45°C to +65°C

FISCO Ex db [ia Ga] IIC T6 Gb; Ta = -45°C to +60°C

PanaFlow PF10 Ultrasonic Liquid Flow Meter

USA/Canada - explosion-proof class I, division 1, groups B, C, and D

ATEX - Flameproof II 2 G Ex db IIB+H2 T6...T3 Gb; Ta = -40°C to +60°C ... +65°C

IECEx - Flameproof Ex db IIB+H2 T6...T3 Gb; Ta = -40°C to +60°C ... +65°C

RoHS compliance (Directive 2011/65/EU)

CE Marking (EMC directive 2014/30/EU, LVD 2014/35/EU, ATEX 2014/34/EU & RoHS 2011/65/EU)

WEEE compliance (Directive 2012/19/EU)

Electronics Mounting

Local or remote mounting Paths Three paths

Display

English

128 x 64 mono-color LCD display, configurable for single or dual measurement parameters

Keypad

Built-in magnetic, six-button, lockable keypad

Standard Inputs/Outputs

One 4 to 20 mA isolated output, 600-ohm maximum load

One additional output, may be configured as either pulse, frequency or alarm.

Additional Inputs/Outputs

Two 4 to 20 mA isolated output, 600-ohm maximum load

Two 4 to 20 mA isolated input or RTD sensor input (Supports PT100: 3 and 4 Wire, PT1000: 3 and 4 Wire)

One additional 4 to 20 mA isolated output (SIL), 600 Ohm maximum load

Digital Interfaces

Standard: RS485/Modbus® Optional: HART® 7.0 protocol, with 4 dynamic variables, includes one additional 4 to 20 mA analog output NAMUR NE43

Optional: Foundation Fieldbus® FISCO, LAS capable NAMUR NE107 with 5 AI blocks and a PID block

Power Supplies

Universal 100–240 VAC 50/60 Hz $\pm 10\%$ or 12 to 28 VDC

Note: For DC-powered meters, Class 2 rated supplies must be used for the line power.

Cable Entries

$\frac{3}{4}$ " NPT As-Standard

M20 Via Adapters

Temperature Range

Operating: -40°F to 140°F (-40°C to $+60^{\circ}\text{C}$)

Storage: -40°F to 158°F (-40°C to 70°C)

Power Consumption

15 Watts maximum

Wiring Connections

Cable entries include $6 \times \frac{3}{4}$ " NPT, consult Panametrics for available adapters

General Installation Conditions

Pollution Degree: 2

Installation Category: 2

Altitude: 2000 m

Ingress Protection: IP66/67

Relative Humidity: 10–90% RH

Data Logging

Storage standard on the meter, up to 10,000 flow data points with up to 25 parameters per data point (requires PanaView™ Plus software)–

A.3 Drawings

Drawings	Description
702-2040	XMT1000 wiring details.

A.4 Wiring Diagram

-01	
PIN	DESCRIPTION
1	ANALOG 4-20MA OUT1 (+)
2	ANALOG 4-20MA OUT1 (-)
3	ANALOG 4-20MA OUT2 (+)
4	ANALOG 4-20MA OUT2 (-)
5	24V SUPPLY OUTPUT1
6	ANALOG 4-20MA IN1 (+)
7	ANALOG 4-20MA IN1 (-)
8	24V SUPPLY RETURN1
9	24V SUPPLY OUTPUT2
10	ANALOG 4-20MA IN2 (+)
11	ANALOG 4-20MA IN2 (-)
12	24V SUPPLY RETURN2

-02 & -06	
PIN	DESCRIPTION
1	ANALOG 4-20MA OUT1 (+)
2	ANALOG 4-20MA OUT1 (-)
3	ANALOG 4-20MA OUT2 (+)
4	ANALOG 4-20MA OUT2 (-)
5	24V SUPPLY OUTPUT1
6	ANALOG 4-20MA IN1 (+)
7	ANALOG 4-20MA IN1 (-)
8	24V SUPPLY RETURN1
9	NO CONNECTION
10	RTD1 SOURCE (+)
11	RTD1 VOLTAGE (+)
12	RTD1 VOLTAGE (-)

-03 & -07	
PIN	DESCRIPTION
1	ANALOG 4-20MA OUT1 (+)
2	ANALOG 4-20MA OUT1 (-)
3	ANALOG 4-20MA OUT2 (+)
4	ANALOG 4-20MA OUT2 (-)
5	NO CONNECTION
6	RTD1 SOURCE (+)
7	RTD1 VOLTAGE (+)
8	RTD1 RETURN
9	NO CONNECTION
10	RTD2 SOURCE (+)
11	RTD2 VOLTAGE (+)
12	RTD1 VOLTAGE (-)

-04 & -08	
PIN	DESCRIPTION
1	ANALOG 4-20MA OUT1 (+)
2	ANALOG 4-20MA OUT1 (-)
3	ANALOG 4-20MA OUT2 (+)
4	ANALOG 4-20MA OUT2 (-)
5	24V SUPPLY OUTPUT1
6	ANALOG 4-20MA IN1 (+)
7	ANALOG 4-20MA IN1 (-)
8	24V SUPPLY RETURN1
9	RTD1 SOURCE (+)
10	RTD1 VOLTAGE (+)
11	RTD1 VOLTAGE (-)
12	RTD1 SOURCE (-)

-05 & -09	
PIN	DESCRIPTION
1	ANALOG 4-20MA OUT1 (+)
2	ANALOG 4-20MA OUT1 (-)
3	ANALOG 4-20MA OUT2 (+)
4	ANALOG 4-20MA OUT2 (-)
5	RTD1 SOURCE (+)
6	RTD1 VOLTAGE (+)
7	RTD1 VOLTAGE (-)
8	RTD1 SOURCE (-)
9	RTD2 SOURCE (+)
10	RTD2 VOLTAGE (+)
11	RTD2 VOLTAGE (-)
12	RTD2 SOURCE (-)

SL	
PIN	DESCRIPTION
1	NO CONNECTION
2	NO CONNECTION
3	NO CONNECTION
4	NO CONNECTION
5	NO CONNECTION
6	NO CONNECTION
7	NO CONNECTION
8	NO CONNECTION
9	NO CONNECTION
10	NO CONNECTION
11	SIL 4-20MA OUT (-)
12	SIL 4-20MA OUT (+)

Appendix B. Modbus map validation

Table 29: Modbus Map validation XMT1000

Category	Measurement	Type	Number of Registers	Format	Composite Register Address		Channel 1 Register Address		Channel 2 Register Address		Channel 3 Register Address	
					In Decimal	In Hex	In Decimal	In Hex	In Decimal	In Hex	In Decimal	In Hex
Primary Measurements	Velocity	F	2	Float	33280	0x8200	34352	0x8630	35376	0x8A30	36400	0x8E30
	Volumetric	F	2	Float	33282	0x8202	34350	0x862E	35374	0x8A2E	36398	0x8E2E
	Std Volumetric	F	2	Float	33306	0x821A	34392	0x8658	35416	0x8A58	36440	0x8E58
	Mass Flow	F	2	Float	33284	0x8204	34354	0x8632	34378	0x8A32	36402	0x8E32
Batch Totals	Forward Volumetric Totals	F	2	Float	33286	0x8206	34356	0x8634	35380	0x8A34	36404	0x8E34
	Reverse Volumetric Totals	F	2	Float	33288	0x8208	34358	0x8636	35382	0x8A36	36406	0x8E36
	Net Volumetric Totals	F	2	Float	33308	0x821C	34364	0x863C	35388	0x8A3C	36412	0x8E3C
	Fwd Std Volumetric Totals	F	2	Float	33332	0x8234	34394	0x865A	35418	0x8A5A	36442	0x8E5A
	Rev Std Volumetric Totals	F	2	Float	33334	0x8236	34396	0x865C	35420	0x8A5C	36444	0x8E5C
	Net Std Volumetric Totals	F	2	Float	33336	0x8238	34398	0x865E	35422	0x8A5E	36446	0x8E5E
	Forward Mass Totals	F	2	Float	33318	0x8226	34368	0x8640	35392	0x8A40	36416	0x8E40
	Reverse Mass Totals	F	2	Float	33320	0x8228	34370	0x8642	35394	0x8A42	36418	0x8E42
	Net Mass Totals	F	2	Float	33326	0x833E	34376	0x8648	35400	0x8A48	36424	0x8E48
Elapsed Total Time	F	2	Float	33290	0x820A	34384	0x8650	35408	0x8A50	36432	0x8E50	
Inventory Tot	Forward Volumetric Totals	F	2	Float	1536	0x0600	1550	0x060E	1564	0x061C	1578	0x062A
	Reverse Volumetric Totals	F	2	Float	1538	0x0602	1552	0x0610	1566	0x061E	1580	0x062C
	Net Volumetric Totals	F	2	Float	1540	0x0604	1554	0x0612	1568	0x0620	1582	0x062E
	Forward Mass Totals	F	2	Float	1544	0x0608	1558	0x0616	1572	0x0624	1586	0x0632
	Reverse Mass Totals	F	2	Float	1546	0x060A	1560	0x0618	1574	0x0626	1588	0x0634
	Net Mass Totals	F	2	Float	1548	0x060C	1562	0x061A	1576	0x0628	1590	0x0636
	Elapsed Total Time	F	2	Float	1542	0x0606	1556	0x0614	1570	0x0622	1584	0x0630
Flow Totals	Avg Volumetric Flow Rate	F	2	Float	33340	0x823C	34400	0x8660	35424	0x8A60	36448	0x8E60
	Forward Volumetric Totals	F	2	Float	33286	0x8206	34356	0x8634	35380	0x8A34	36404	0x8E34
	Reverse Volumetric Totals	F	2	Float	33288	0x8208	34358	0x8636	35382	0x8A36	36406	0x8E36
	Net Volumetric Totals	F	2	Float	33308	0x821C	34364	0x863C	35388	0x8A3C	36412	0x8E3C
	Fwd Std Volumetric Totals	F	2	Float	33332	0x8234	34394	0x865A	35418	0x8A5A	36442	0x8E5A
	Rev Std Volumetric Totals	F	2	Float	33334	0x8236	34396	0x865C	35420	0x8A5C	36444	0x8E5C
	Net Std Volumetric Totals	F	2	Float	33336	0x8238	34398	0x865E	35422	0x8A5E	36446	0x8E5E
	Forward Mass Totals	F	2	Float	33318	0x8226	34368	0x8640	35392	0x8A40	36416	0x8E40
	Reverse Mass Totals	F	2	Float	33320	0x8228	34370	0x8642	35394	0x8A42	36418	0x8E42
	Net Mass Totals	F	2	Float	33326	0x822E	34376	0x8648	35400	0x8A48	36376	0x8E48
Elapsed Total Time	F	2	Float	33290	0x820A	34384	0x8650	35408	0x8A50	36432	0x8E50	

Table 29: Modbus Map validation XMT1000

Category	Measurement	Type	Number of Registers	Format	Composite Register Address		Channel 1 Register Address		Channel 2 Register Address		Channel 3 Register Address	
					In Decimal	In Hex	In Decimal	In Hex	In Decimal	In Hex	In Decimal	In Hex
Primary Diagnostics	Sound Speed	F	2	Float	33292	0x820C	34306	0X8602	35330	0x8A02	36354	0x8E02
	Raw Velocity	F	2	Float	33338	0x823A	34304	0x8600	35328	0x8A00	36352	0x8E00
	Transit Time up	F	2	Float	Not Applicable		34308	0x8604	35332	0x8A04	36356	0x8E04
	Transit Time down	F	2	Float			34310	0x8606	35334	0x8A06	36358	0x8E06
	Delta T	F	2	Float			34312	0x8608	35336	0x8A08	36360	0x8E08
	Active Tw Up	F	2	Float			34332	0x861C	35356	0x8A1C	36380	0x8E1C
Active Tw Down	F	2	Float	34314			0x860A	35338	0x8A0A	36362	0x8E0A	
Transit Time Diagnostics	Gain Up[dB]	F	2	Float			Not Applicable		34324	0x8614	35348	0x8A14
	Gain down[dB]	F	2	Float	34326	0x8616			35350	0x8A16	36374	0x8E16
	SNR up	F	2	Float	34328	0x8618			35352	0x8A18	36376	0x8E18
	SNR Down	F	2	Float	34330	0x861A			35354	0x8A1A	36378	0x8E1A
	Amplitude Up	F	2	Float	34320	0x8610			35344	0x8A10	36368	0x8E10
	Amplitude down	F	2	Float	34322	0x8612			35346	0x8A12	36370	0x8E12
	Gain Std. Dev	F	2	Float	34388	0x8654			35412	0x8A54	36436	0x8E54
	Soundspeed Std.Dev	F	2	Float	33330	0x8232	Not Applicable					
	Peak Up	I	2	Integer	Not Applicable		34564	0x8704	35588	0x8B04	36612	0x8F04
	Peak Down	I	2	Integer			34566	0x8706	35590	0x8B06	36614	0x8F06
	Peak % up	I	2	Integer			34568	0x8708	35592	0x8B08	36616	0x8F08
	Peak % down	I	2	Integer			34570	0x870A	35594	0x8B0A	36618	0x8F0A
Active Tw Diagnostics	Active Tw Gain up[dB]	F	2	Float	Not Applicable		34342	0x8626	35366	0x8A26	36390	0x8E26
	Active Tw Gain Down[dB]	F	2	Float			34344	0x8628	35368	0x8A28	36392	0x8E28
	Active Tw SNR up	F	2	Float			34334	0x861E	35358	0x8A1E	36382	0x8E1E
	Active Tw SNR Down	F	2	Float			34336	0x8620	35360	0x8A20	36384	0x8E20
	Active Tw Amplitude Up	F	2	Float			34338	0x8622	35362	0x8A22	36386	0x8E22
	Active Tw Amplitude Down	F	2	Float			34340	0x8624	35364	0x8A24	36388	0x8E24
	Active Tw Peak Up	I	2	Integer			34574	0x870E	35598	0x8B0E	36622	0x8F0E
	Active Tw Peak Down	I	2	Integer			34576	0x8710	35600	0x8B10	36624	0x8F10
	Active Tw Peak % Up	I	2	Integer			34578	0x8712	35602	0x8B12	36626	0x8F12
Active Tw Peak % Down	I	2	Integer	34580	0x8714	35604	0x8B14	36628	0x8F14			
Inputs	Reynolds #	F	2	Float	33316	0x8224	Not Applicable					
	Reynolds Factor	F	2	Float	33302	0x8216	Not Applicable					
	Calibration Factor	F	2	Float	33300	0x8214	34348	0x862C	35372	0x8A2C	36396	0x8E2C
	Fluid temperature Input	F	2	Float	16900	0x4204	Not Applicable					
	Supply Temperature Input	F	2	Float	16902	0x4206						
	Return Temperature Input	F	2	Float	16904	0x4208						
	Pressure Input	F	2	Float	16906	0x420A						
Density Input	F	2	Float	16898	0x4202							

Table 29: Modbus Map validation XMT1000

Category	Measurement	Type	Number of Registers	Format	Composite Register Address		Channel 1 Register Address		Channel 2 Register Address		Channel 3 Register Address	
					In Decimal	In Hex	In Decimal	In Hex	In Decimal	In Hex	In Decimal	In Hex
Meter health Indicators	Flow Health Code	B	2	Unsigned Integer - Bit Field	33536	0x8300	34560	0x8700	35584	0x8B00	36608	0x8F00
	Prioritized Flow Error	I	2	Unsigned Integer	33540	0x8304	34562	0x8702	35586	0x8B02	36610	0x8F02
	System health Code	B	2	Unsigned Integer - Bit Field	33538	0x8302	Not Applicable					
Comm Settings	Baud Rate	I	2	Unsigned Integer	1408	0x0580	Not Applicable					
	Parity	I	2	Unsigned Integer	1410	0x0582						
	Stop Bits	I	2	Unsigned Integer	1412	0x0584						
	Meter Addr	I	2	Unsigned Integer	1414	0x0586						

[no content intended for this page]

Appendix C. Error code bit-field representation

Table 30: Flow Error Codes in Bit Field Values

Error representation	Error Description	Error code (in Hex)
E0	No Error	0x00000000
E29	Velocity Warning	0x00000001
E22	Single Channel Accuracy Error	0x00000002
E23	Multi-Channel Accuracy Error	0x00000004
E15	Active TW Error	0x00000008
E6	Cycle Skip Error	0x00000010
E5	Amplitude Error	0x00000020
E4	Signal Quality Error	0x00000040
E3	Velocity Range Error	0x00000080
E2	Sound Speed Error	0x00000100
E1	SNR Error	0x00000200
E27	Invalid K-Table Error	0x08000000
E28	Software Fault	0x10000000
E31	Not Calibrated Error	0x40000000

Table 31: System Error Codes in Bit Field Values

Error representation	Error Description	Error code (in Hex)
S0	No Error	0x00000000
S1	In Config Mode	0x00000001
S2	Invalid User	0x00000002
S3	Invalid Request	0x00000004
S4	Invalid Parameter Range	0x00000008
S5	Unsupported Parameter	0x00000010
S6	Flow Measurement	0x00000020
S7	Persistent Parameters CRC failed	0x00000040
S8	Multiplexer Switch Test Failed	0x00000080
S9	ADC Bit Test Failed	0x00000100
S10	VGA Test Failed	0x00000200
S11	Clock Frequency Test Failed	0x00000400
S12	CPU Test Failed	0x00000800
S13	Invariable Flash Memory Test Failed	0x00001000
S14	Invariable SRAM Memory Test Failed	0x00002000
S15	Variable Memory Test Failed	0x00004000
S16	FPGA Configuration Test Failed	0x00008000
S17	Temperature Test Failed	0x00010000
S18	Driver Fault	0x00020000
S19	Watch-dog Test Failed	0x00040000
S20	Analog Readback Failure	0x00080000

Table 31: System Error Codes in Bit Field Values

Error representation	Error Description	Error code (in Hex)
S21	Stack overflow	0x00100000
S22	Sequence or Windowed watchdog failure	0x00200000
S23	Initialization failed	0x00400000
S24	DSP Hardware Errors	0x00800000
S25	DSP Exception	0x01000000
S26	Default ISR	0x02000000
S27	DSP Reset	0x04000000
S28	Software Fault	0x08000000
S29	Output A loop Open	0x10000000
S30	Flash Save Failed	0x20000000

Table 32: Communication Error Codes in Bit Field Values

Error representation	Error Description	Error code (in Hex)
C0	No Error	0x00000000
C1	Flow COMM Error	0x00000001
C2	MODE MISMATCH	0x00000002
C3	Option I/O COMM Error	0x00000004

Table 33: Transmitter Error Codes in Bit Field Values

Error representation	Error Description	Error code (in Hex)
X0	No Error	0x00000000
X1	MCU RAM Error	0x00000001
X2	Flash memory test failed	0x00000002
X3	MCU key chip error	0x00000004
X4	MCU voltage chip error	0x00000008
X5	MCU RTC chip error	0x00000010
X6	OPT board not detected	0x00000020
X7	MPU board not detected	0x00000040
X8	MCU voltage out of limit	0x00000080
X9	MCU Pulse registration fail	0x00000100
X10	MCU file read fail	0x00000200
X11	MCU register access fail	0x00000400
X12	System Command failed	0x00000800
X13	Get GUI Node Fail	0x00001000
X14	Node Memory Fail	0x00002000
X15	Font API Initialize Fail	0x00004000
X16	XML File Initialize Fail	0x00008000
X17	Disconnect Std Dout	0x00010000
X18	Aout(std) Out Of Range	0x00020000

Table 34: Option I/O Errors in Bit Field Values

Error representation	Error Description	Error code (in Hex)
A0	No Error	0x00000000
A1	AnalogCh (S2:3) Error!	0x00000001
A2	AnalogCh (S2:4) Error!	0x00000002
A3	AnalogCh (S2:1) Error!	0x00000004
A4	AnalogCh (S2:2) Error!	0x00000008
A6	(S2:3) Ch Not Calibrated	0x00000020
A7	(S2:4) Ch Not Calibrated	0x00000040
A8	(S2:1) Ch Not Calibrated	0x00000080
A9	(S2:2) Ch Not Calibrated	0x00000100
A10	(S2:3) Input NotConnect!	0x00000200
A11	(S2:4) Input NotConnect!	0x00000400
A12	(S2:3) Ch OverRange Err!	0x00000800
A13	(S2:4)Ch OverRange Err!	0x00001000
A18	SerialNo Error!	0x00020000
A24	Aout(S2:1)OutOfRange!	0x00800000
A25	Aout(S2:2)OutOfRange!	0x01000000
A30	Board Option Err!	0x20000000
A31	(S2:3) Ch UnderRange!	0x40000000
A32	(S2:4) Ch UnderRange!	0x80000000

[no content intended for this page]

Appendix D. HART Communication

D.1 Wiring the XMT1000 to the HART Communicator

When connecting a HART communicator to the wiring terminals on the XMT1000 electronics terminal board, the circuit must be terminated in an appropriate resistive load, as shown in *Figure 61* below. The HART communicator is connected in parallel with that load.

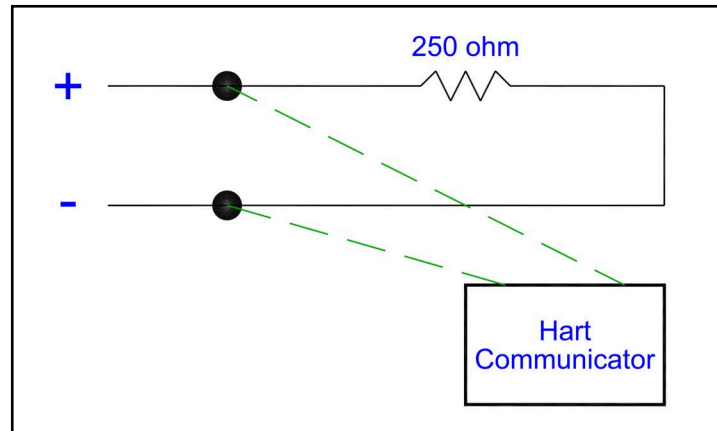

Figure 61: Wiring Diagram for HART Communication

D.2 HART Write Mode Switch

The XMT1000 HART circuit includes a slide switch which can be used to disable write access to the instrument via HART. This slide switch (pictured in *Figure 62* below) is designed to lock out HART configuration access for those customers who require this extra level of security. With the *Write Mode* switch pushed to the right, the HART circuit is in *write enabled* mode.

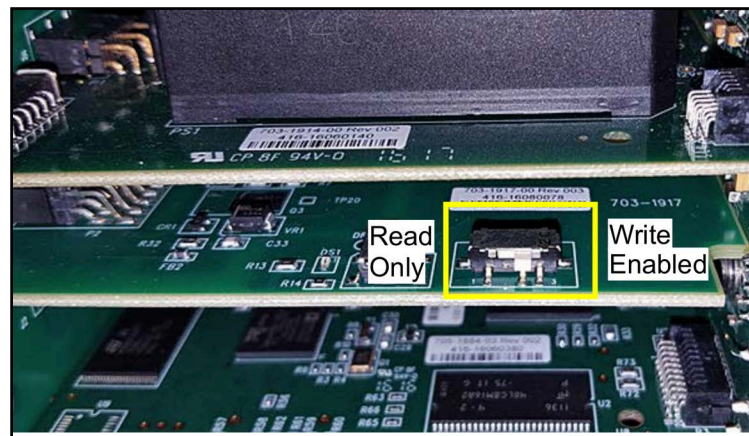

Figure 62: HART Circuit Write Mode Switch

Note: The following sections of this Appendix provide menu maps for programming the XMT1000 via HART communication. To make programming changes through HART, the HART circuit must be set to Write Enabled mode. Attempting to write to a device in Read Only mode will cause the device to indicate that the meter is in Write-Protect mode.

IMPORTANT: Modification of the HART RO/RW switch from disabled is not recommended.

D.3 DD File

The DD file can be found on the Foundation Fieldbus website www.fieldcommgroup.org under **Panametrics** as manufacturer and **XMT1000** as model. It may also be found on the DCS vendor website if available. HART Menu Maps

For reference while programming the XMT1000, see the following HART menu maps:

- "HART Output Menu Map" on page 92
- "HART Review Menu Map" on page 93

D.3.1 HART Output Menu Map

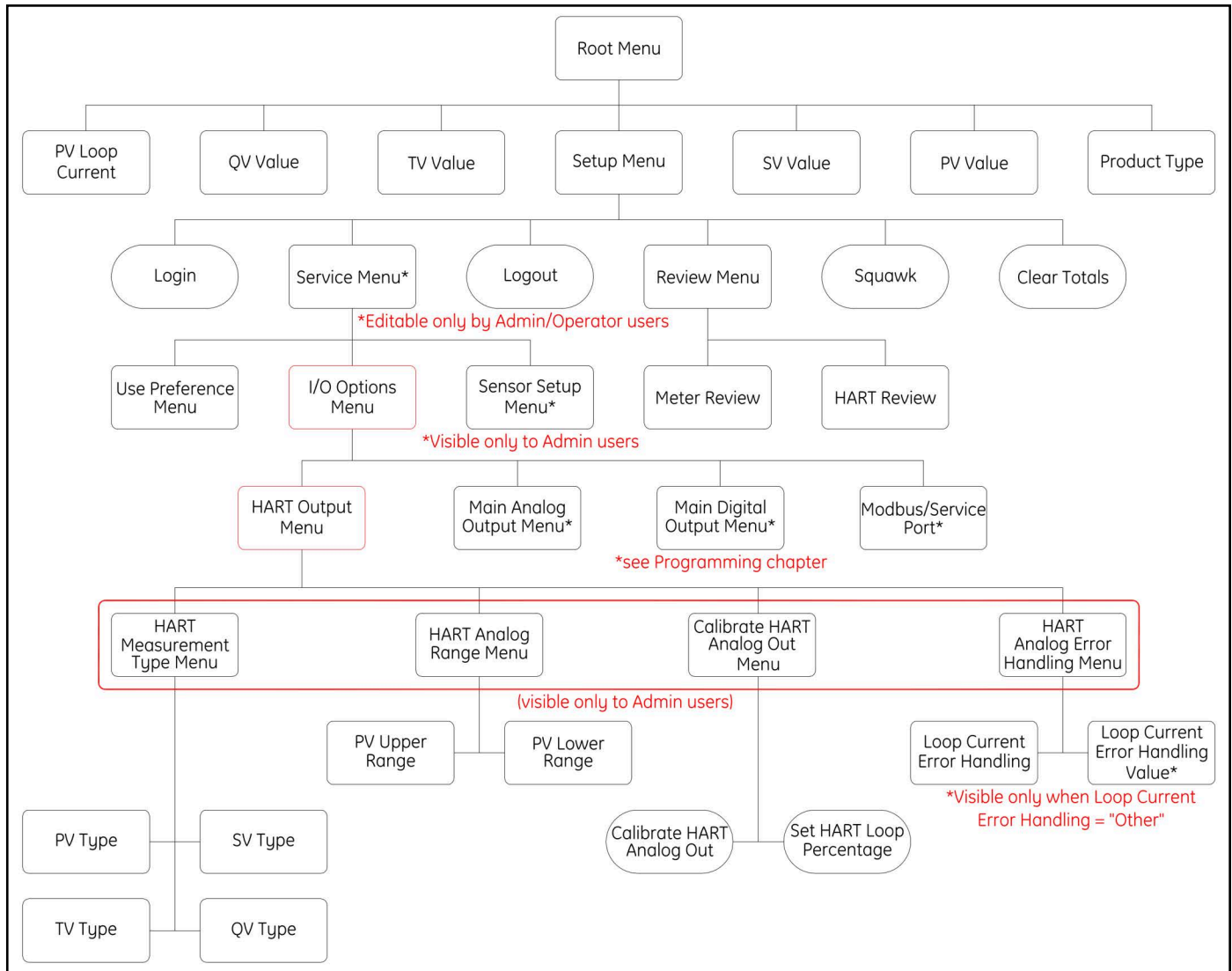

Figure 63: HART Output Menu Map

D.3.2 HART Review Menu Map

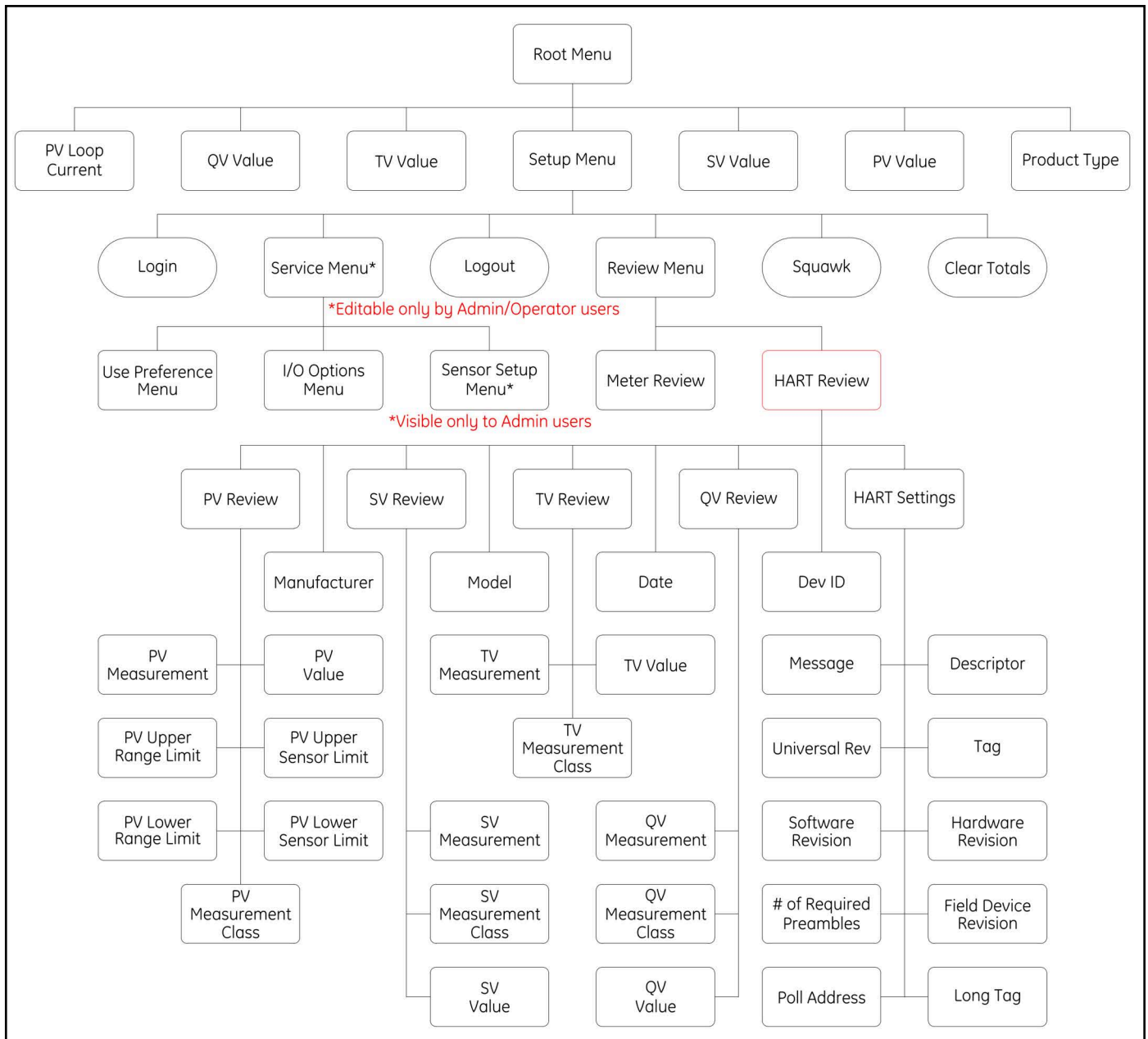

Figure 64: HART Review Menu Map

D.4 Configurable Measurements

Below table shows the measurements available over HART:

Table 35: Measurements Available Over HART

Velocity	Ch 1 ActiveTw Amplitude Down	Ch 2 Peak Index Up
Volumetric	Ch 1 ActiveTw Gain Up	Ch 2 Peak Index Down
Mass Flow	Ch 1 ActiveTw Gain Down	Ch 2 Peak % Up
Batch Fwd Volumetric Totals	Ch 1 Error Status	Ch 2 Peak % Down
Batch Rev Volumetric Totals	Ch 1 Reported Error	Ch 2 No. Of Errors
Totalizer Elapsed Time	Ch 1 Peak Index Up	Ch 3 Velocity
Soundspeed	Ch 1 Peak Index Down	Ch 3 Soundspeed
Inventory Fwd Volumetric Totals	Ch 1 Peak % Up	Ch 3 Transit Time Up
Inventory Rev Volumetric Totals	Ch 1 Peak % Down	Ch 3 Transit Time Down
Inventory Totalizer Elapsed Time	Ch 1 No. Of Errors	Ch 3 DeltaT
Meter Factor	Ch 2 Velocity	Ch 3 ActiveTw Down
Standard Volumetric	Ch 2 Soundspeed	Ch 3 Signal Quality Up
Batch Net Volumetric Totals	Ch 2 Transit Time Up	Ch 3 Signal Quality Down
Inventory Net Volumetric Totals	Ch 2 Transit Time Down	Ch 3 Amplitude Up
Reynolds Number	Ch 2 DeltaT	Ch 3 Amplitude Down
Ch 1 Velocity	Ch 2 ActiveTw Down	Ch 3 Gain Up
Ch 1 Soundspeed	Ch 2 Signal Quality Up	Ch 3 Gain Down
Ch 1 Transit Time Up	Ch 2 Signal Quality Down	Ch 3 SNR Up
Ch 1 Transit Time Down	Ch 2 Amplitude Up	Ch 3 SNR Down
Ch 1 DeltaT	Ch 2 Amplitude Down	Ch 3 ActiveTw Up
Ch 1 ActiveTw Down	Ch 2 Gain Up	Ch 3 ActiveTw SNR Up
Ch 1 Signal Quality Up	Ch 2 Gain Down	Ch 3 ActiveTw SNR Down
Ch 1 Signal Quality Down	Ch 2 SNR Up	Ch 3 ActiveTw Amplitude Up
Ch 1 Amplitude Up	Ch 2 SNR Down	Ch 3 ActiveTw Amplitude Down
Ch 1 Amplitude Down	Ch 2 ActiveTw Up	Ch 3 ActiveTw Gain Up
Ch 1 Gain Up	Ch 2 ActiveTw SNR Up	Ch 3 ActiveTw Gain Down
Ch 1 Gain Down	Ch 2 ActiveTw SNR Down	Ch 3 Error Status
Ch 1 SNR Up	Ch 2 ActiveTw Amplitude Up	Ch 3 Reported Error
Ch 1 SNR Down	Ch 2 ActiveTw Amplitude Down	Ch 3 Peak Index Up
Ch 1 ActiveTw Up	Ch 2 ActiveTw Gain Up	Ch 3 Peak Index Down
Ch 1 ActiveTw SNR Up	Ch 2 ActiveTw Gain Down	Ch 3 Peak % Up
Ch 1 ActiveTw SNR Down	Ch 2 Error Status	Ch 3 Peak % Down

Table 35: Measurements Available Over HART

Ch 1 ActiveTw Amplitude Up	Ch 2 Reported Error	Ch 3 No. Of Errors
Meter Information		
Flow board Serial number	Sensor 1 Dn Serial number	Sensor 3 Up Serial number
Flow board hardware revision	Sensor 2 Up Serial number	Sensor 3 Dn Serial number
Sensor 1 Up Serial number	Sensor 2 Dn Serial number	

Table 36: Configurable through HART

Pipe Configurations	Pipe Outer Diameter
	Pipe Wall Thickness
	Pipe Inner Diameter
Fluid Configurations	Kinematic Viscosity
Limits	Zero Cutoff
	Flow Averaging
Path Configuration	Path Configuration
	Path Error Handling
	Ch 1 Path Weight
	Ch 2 Path Weight
	Ch 3 Path Weight
	Ch 1 Path Length
	Ch 2 Path Length
	Ch 3 Path Length
	Ch 1 Axial Length
	Ch 2 Axial Length
	Ch 3 Axial Length
Transducer Configurations	Ch 1 Transducer Type
	Ch 1 Transducer Number
	Ch 1 Transducer Frequency
	Ch 1 Static Tw
	Ch 2 Transducer Type
	Ch 2 Transducer Number
	Ch 2 Transducer Frequency
	Ch 2 Static Tw
	Ch 3 Transducer Type
	Ch 3 Transducer Number
	Ch 3 Transducer Frequency
	Ch 3 Static Tw

Table 36: Configurable through HART

Standard IO	
	Communication Option Type Selection
	Standard Analog Output (AO) Error handling
	Standard Digital Output (DO) Type
	DO Pulse Measurement Type
	DO Pulse Unit Group selection
	DO Pulse value
	DO Pulse width
	DO Pulse Error handling
	DO Frequency Measurement Type
	DO Frequency Unit Group selection
	DO Frequency Base value
	DO Frequency Full Value
	DO Frequency Full Frequency
	DO Frequency Error handling
	DO Frequency Error handling value

Appendix E. Wireless HART Communication

E.1 Introduction

Wireless HART is a bi-directional digital communication protocol for field devices, that offers multi-vendor, inter-operable wireless standard. It is an advancement in technologies for process control systems and is widely employed by numerous field devices.

The XMT1000 flowmeter has integrated HART communication with 4–20mA output. Masoneilan VECTOR V1100 Wireless HART adaptor is used along with XMT1000 flowmeter to setup as Wireless HART node. The below steps will guide to configure XMT1000 flowmeter to work with the Masoneilan VECTOR adaptor.

E.2 Installation and Configuration

The following instruments are required for complete setup:

- XMT1000 flowmeter with HART option
- Masoneilan VECTOR V1100 Wireless HART adaptor.

E.2.1 XMT1000 to Masoneilan VECTOR Connection

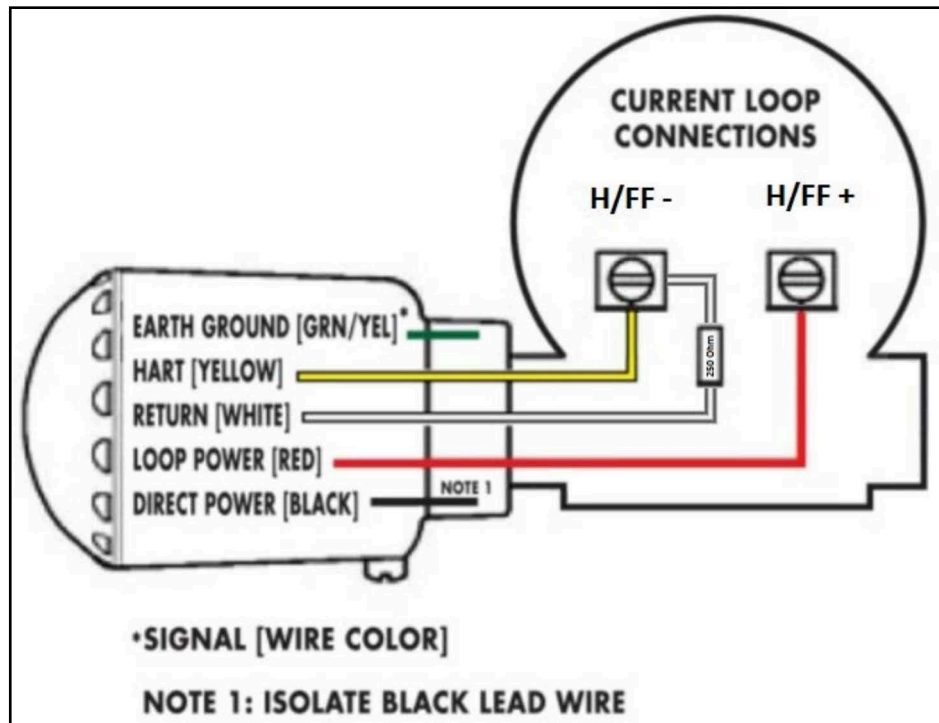

Note: Make sure to add the 250 Ω resistor across the white and yellow wires.

E.2.2 XMT1000 configuration

1. Program the 4 variables for HART digital output
 - PV
 - SV
 - TV
 - QV
2. Typical measurements include Volumetric Flow, Totals, Velocity, Soundspeed etc. but are application dependent.
3. Configure the meter so that it is not in error, systems without errors will be easier to troubleshoot later in the process.
4. Assign the meter a unique Tag and Long Tag so that they can be easily identified on the HART network.

E.2.3 Masoneilan VECTOR V1100 Adaptor configuration

This step will configure the VECTOR adaptor so that it will be recognized by the wireless Gateway.

1. Connect an Emerson 475 communicator across the 250 Ω resistor installed in the previous step.
2. Turn the communicator on and select HART from the menu. If the Emerson 475 is setup to scan addresses 0-16 then it should see the VECTOR adapter. Please note that the default VECTOR address is 15.
3. If the 475 does not see the VECTOR adapter, verify that the scan settings are correct:
 - Press 3, for Utility
 - Press 1, for Configure HART Application
 - Press 2, Polling Addresses
 - Scroll to (0-15) and press enter
 - Escape back to the main menu
4. Setup Tag: Program a unique tag name for the VECTOR adapter, so that it is easily recognizable.
 - a. Select HART application
 - b. Press 2, Online
 - c. Press 2, Configure
 - d. Press 2, Manual Setup
 - e. Press 7, Device Information
 - f. Press 2, Long Tag
 - g. Type Tag name and select enter to program the tag name into the VECTOR adapter
5. Setup network ID and Join Key - These values need to be programmed into the VECTOR adapter so that it can join the Wireless Gateway network. Please note these values are found with the Emerson Gateway documentation and may be different for different networks.
 - a. Select HART application
 - b. Press 2, Online
 - c. Press 2, Configure
 - d. Press 2, Manual Setup
 - e. Press 2, Wireless
 - f. Press 2, Join Device to Network
 - g. Enter the Network ID and Join Key for your network

E.2.4 Emerson Wireless Gateway Setup configuration

The following information will show how to configure the Wireless Gateway with a STATIC IP to a dedicated PC, this can be useful as a diagnostic tool.

Note: *This is not a typical end user application but can be used as a diagnostic tool at the customer site, the gateway may already be setup at the customer site per their procedures.*

1. Connect +24VDC power to the wireless Gateway. Refer to the label on the inside cover of the Gateway.
2. Connect a Crossover cable from the Ethernet 1 port of the gateway and the Ethernet port on the PC.
3. Configure the PC TCP/IP Settings (Note this information can be found in the Gateway manual).
 - a. Open: A network settings in the PC control panel.
 - b. Select TCP/IP and Properties.
 - c. Record any current static IP settings, before making changes so that the PC can be returned to its original state.
 - d. Select "Use the following IP Address" box.
 - e. Input 192.168.1.12 in the IP Address block.
 - f. Input 255.255.255.0 in the Subnet Mask.
 - g. Select OK for both TCP/IP and LAN properties Windows.
4. Disable Proxies.
 - a. Open the standard Web browser on the PC.
 - b. Navigate to **Tool->Internet Options->Connections->LAN Settings**.
 - c. Uncheck the Proxy Server Box.
5. Configure the Wireless Gateway.
 - a. Under web server, type address `https://192.168.1.10`.
 - Log in as User: admin and Password: default.
 - b. Navigate to Setup->Internet Protocol Screen.
 - Verify the Specify an IP Address box is checked.
 - Set IP Address to 192.168.1.10.
 - Set mask to 255.255.255.0.
 - Set Gateway to 192.168.1.12 (Note: this is the IP Address on the PC)
6. Verify operation: Note that HART is a slow protocol, Wireless HART is even slower, so be patient waiting for the Gateway to see the VECTOR.
 - a. Look at the Network Overview page to see if there are any "live" devices on the network.
 - b. When visible switch to the Explorer page to see the VECTOR adapter and Wireless HART Data.

[no content intended for this page]

Appendix F. Foundation Fieldbus Communication

F.1 Introduction

Fieldbus is a bi-directional digital communication protocol for field devices, which offers an advancement in technologies for process control systems and is widely employed by numerous field devices.

The **XMT1000 FF** option is designed to the specification standardized by the *Fieldbus Foundation*, and provides interoperability with devices produced by other manufacturers. The Fieldbus option **PCB** comes with software consisting of five **AI** function blocks and one **PID** function block.

Note: *For more general information on other features, engineering, design, construction work, startup and maintenance of Fieldbus, refer to Fieldbus Technical Information (TI 38K3A01-01E).*

F.2 Installation

F.2.1 Network Configuration

The following instruments are required for use with Fieldbus devices:

- **Power supply:** Fieldbus requires a dedicated power supply. It is recommended that current capacity be well over the total value of the maximum current consumed by all devices (including the host). Conventional DC current cannot be used as is.
- **Terminators:** Fieldbus requires two terminators. Refer to the supplier for details of terminators that are attached to the host.
- **Field devices:** Connect the field devices necessary for instrumentation. XMT1000 has passed the interoperability test conducted by the Fieldbus Foundation. To properly start Fieldbus, use devices that satisfy the requirements of the above test.
- **Host:** Used for accessing field devices. A dedicated host (such as DCS) is used for an instrumentation line while dedicated communication tools are used for experimental purposes.

F.2.2 Polarity

The XMT1000 Foundation Fieldbus terminals are marked (+) and (-). However, the design is polarity insensitive. This means the XMT1000 will communicate even if the connections are reversed.

F.2.3 Connection

Connect the Fieldbus wires to **P1** on the terminal PCB (see Figure 65 below). Panametrics recommends using the top right rear port on the enclosure.

IMPORTANT: Please make sure to follow all local installation guidelines.

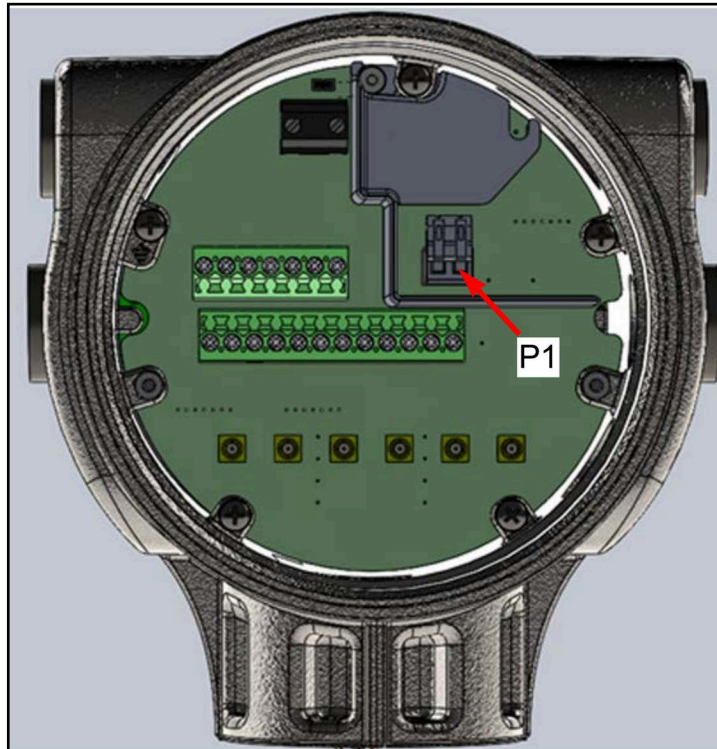

Figure 65: FF Connection to XMT1000

F.2.4 FISCO (Fieldbus Intrinsically Safe Concept)

The XMT1000 Fieldbus is certified as a **FISCO** connection for both *entity* and *FISCO* parameters:

- **FISCO Parameters**
 V_{\max} or $U_i = 17.5$ V
 I_{\max} or $L_i = 380$ mA
 $C_i = 0$
 $L_i = 10$ μ H
 $P_i = 5.32$ W
- **Entity Parameters**
 V_{\max} or $U_i = 24$ V
 I_{\max} or $L_i = 250$ mA
 $C_i = 0$
 $L_i = 10$ μ H
 $P_i = 5.32$ W

Note: The XMT1000 FISCO control drawing is Panametrics drawing #752-584. Please consult the factory for a copy of the drawing.



Attention: The FISCO cover must be installed to comply with FISCO guidelines.

IMPORTANT: The FISCO cover on the XMT1000 terminal PCB is required to provide a barrier between IS and non-IS connections. This cover must be installed if the Fieldbus application is FISCO.

The FISCO cover should come installed from the factory, as shown in *Figure 66* below. The Fieldbus cables should be installed through the XMT1000 upper right port for direct entry into the FISCO zone on the terminal PCB.

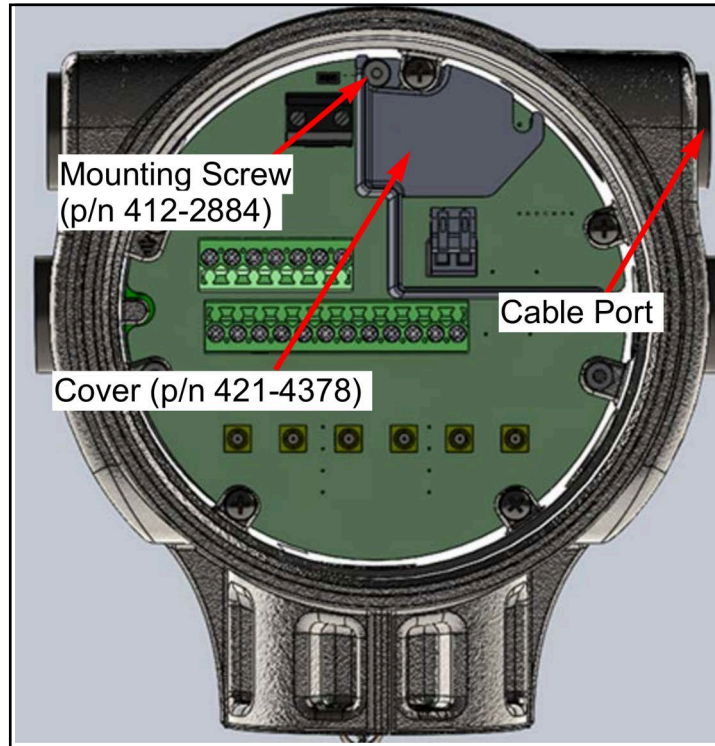

Figure 66: Installed FISCO Cover and Mounting Screw

F.2.5 DD File

The DD file can be found on the Foundation Fieldbus website www.fieldcommgroup.org under **Panometrics** as manufacturer and **XMT1000** as model. It may also be found on the DCS vendor website if available.

F.2.6 Default Node Address

The *default node address* for each XMT1000 flow meter from the factory is **17** (see *Figure 67* below). This should be changed during commissioning.



Figure 67: XMT1000 Device Properties

F.3 Specifications

F.3.1 General

Manufacturer Name:	Panametrics
Manufacturer ID (Hex):	004745
Model:	XMT1000
Device Type:	0010
FF Device Revision:	For latest, see Fieldbus Foundation website
FISCO Compliant:	Yes
Hazardous Location Certs:	See drawing 752-584
ITK Revision:	6.2
Protocol:	H1
Protocol Baud (bps):	31.25k
DD and CFF Files:	For latest, see Fieldbus Foundation website
Meter Programmable through FF:	Yes

F.3.2 Physical

Polarity Sensitive (Yes/No):	No
Quiescent Current Draw (mA):	26
Working Voltage:	9-32 VDC

F.3.3 Communication

Stack Manufacturer:	Softing AG
Backup LAS Capable:	Yes*
Total Number of VCRs:	24
Fixed VCRs for Configuration:	1

*LAS means Link Active Scheduler. It can schedule a network if the main LAS fails.

F.3.4 User Layer

FB Application Manufacturer: Softing AG
 Function Blocks: 5-AI(e), 1-PID
 Supports Block Instantiation: No
 Firmware Upgrade over Fieldbus: No
 Configuration Write Protect: HW Jumper on PCB

F.3.5 Function Blocks

Resource Block Class Type: Enhanced (Field Diagnostics)
 Transducer Blocks: XMIT, COMPOSIT CH, CH 1, CH 2, CH 3
 Transducer Block Class Type: Custom
 Function Blocks: AI (5), PID
 FB Execution Time (ms): 20, 40
 Function Block Class Type: Standard

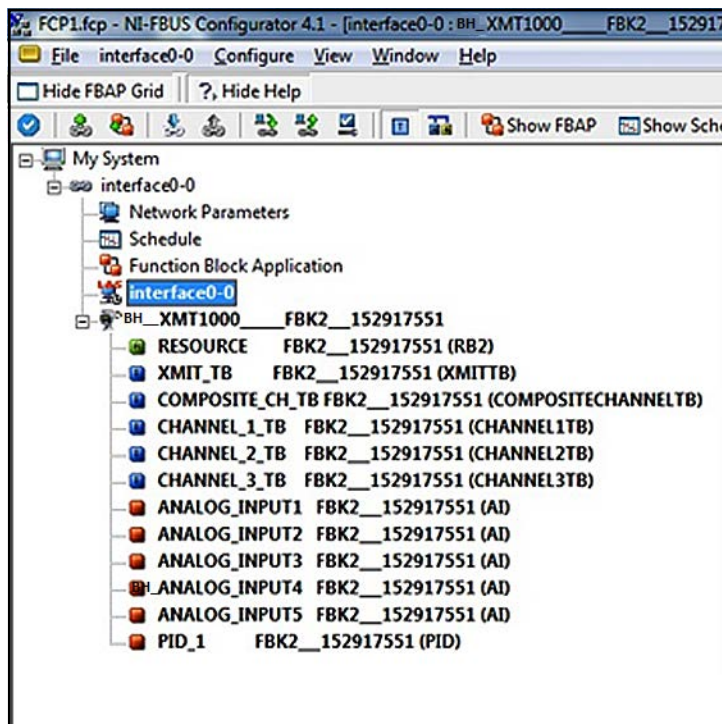

Figure 68: XMT1000 FF Blocks

F.4 Resource Block

The *Resource Block* provides common information about the XMT1000 Foundation Fieldbus implementation. The user can find FF revision numbers, set passwords and configure the **NAMUR NE107** bit map.

F.4.1 FF Revision

Figure 69 below shows the Foundation Fieldbus **SW** and **HW** versions in the XMT1000 *Resource Block*, and includes an *FF Revision* for both.

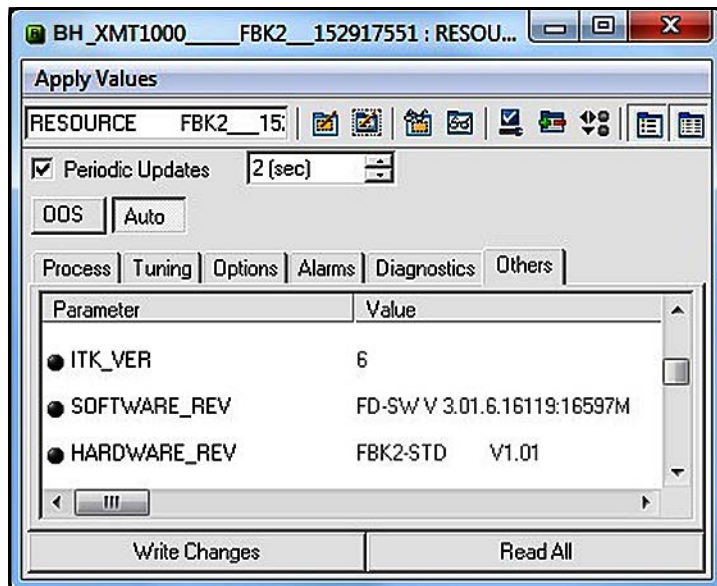

Figure 69: FF Revision in XMT1000 Resource Block

F.4.2 Password

A password must be entered to change XMT1000 system parameters. This can be done using Foundation Fieldbus. There are different levels of security for different Passwords (**Admin** or **Operator**). Please see the standard manual for more detail on password levels. *Figure 70* below shows the password fields in the XMT1000 Resource Block.

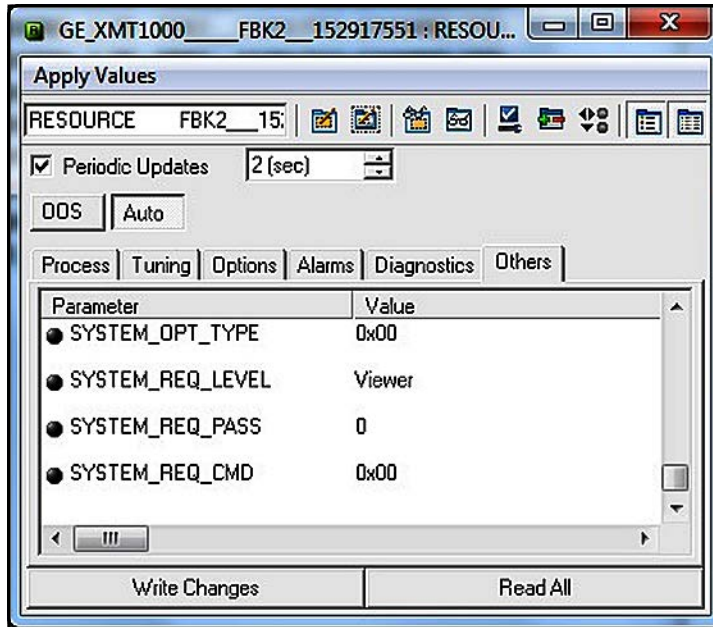

Figure 70: Password Fields in XMT1000 Resource Block



Attention: Before entering a password, make sure the **XMIT_TB** transducer block is in active mode.

To *Enter* configuration mode, complete the following steps:

1. Select the **Resource Block > Others** tab.
2. Select **SYSTEM_OPT_TYPE** and set to **Option FI**.
3. Select **SYSTEM_REQ_LEVEL** and set to **Admin** or **Operator**.
4. Enter the **Admin** or **Operator** password into the **SYSTEM_REQ_PASS** field.
5. Select **Cancel** from the **SYSTEM_REQ_CMD** drop down box.
6. Select **Login** from the **SYSTEM_REQ_CMD** drop down box.
7. Click on the **Write Changes** button.
8. Verify that **SI:In Config Mode** appears on XMT1000 display. You should now be able to edit fields with **Admin** privileges.

To *Edit* the fields in the *Transducer Blocks*, complete the following steps:

1. Select or enter the **new value**.
2. Click on the **Write Changes** button.
3. Return to the **Resource Block > Others** tab and select **Commit** from the **SYSTEM_REQ_COM** drop down box
4. Click on the **Write Changes** button.

To *Exit* configuration mode, complete the following steps:

1. Select **Cancel** from the **SYSTEM_REQ_CMD** drop down box.
2. Click on the **Write Changes** button.

Note: The XMT1000 will automatically exit configuration mode after 5 minutes of inactivity.

F.4.3 NAMUR NEI07

The **NAMUR NEI07** recommendation specifies that detailed device-specific diagnostics are summarized as four simple status signals. The diagnostics are set to defaults by Panametrics, but they can be modified to any other level by the user. The four status signals are:

- **Failed:** This category is typically used for hardware or software failures. The meter output is not valid. Consult with the factory for a resolution.
- **Offspec:** This category is typically used for application, installation, or process problems. Consult the troubleshooting section of this appendix or contact Panametrics customer service for assistance.
- **Check:** This category means the output of the device is invalid due to on-going work on the device, such as programming, etc.
- **Maintenance:** This category is typically used to assign parameters that are in good status but which may fall out of specification due to some process condition or wear factor. There are no diagnostics set as default in this category.

The status signals (see *Figure 71* below) can either be reported as errors (**ACTIVE**) or masked when the error occurs (**MASK**). There are no default settings for the **MASK** bits.

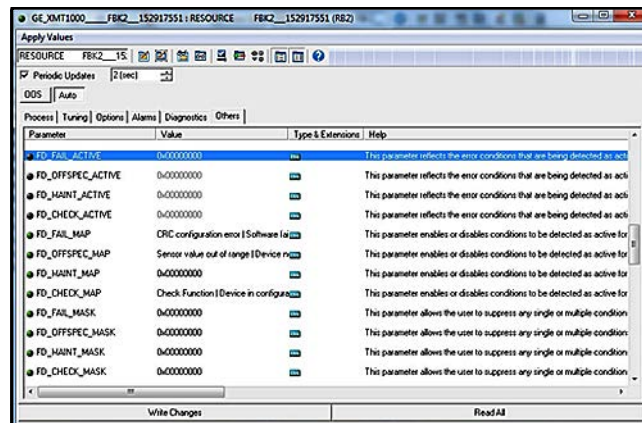

Figure 71: NAMUR NEI07 Configuration in Resource Block

The **NAMUR NE107** Errors and their *Default Categories* in the XMT1000 **Resource Block** are listed in Table 37 below.

Table 37: NAMUR NE107 Errors and XMT1000 Default Categories

Error	Sub-Error Description	Default Category
CRC Configuration Error	Persistent Parameter CRC Fault	Failed
Software Failure	Stack Overflow failure	Failed
	Sequence or Windowed Watch Dog failure	Failed
	Software fault	Failed
Device Initialization Failure	Initialization failed	Failed
Hardware Failure	ADC Bit Test Fault	Failed
	VGA test Fault	Failed
	Clock Frequency Fault	Failed
	CPU test Fault	Failed
	Invariable Flash Memory Fault	Failed
	Variable Memory Fault	Failed
	FPGA Configuration CRC fault	Failed
	Temperature Test Fault	Failed
	Driver Failure	Failed
	Watch Dog failure	Failed
	DSP Hardware Errors	Failed
	Default ISR (DSP Exception)	Failed
	DSP Exception	Failed
Modbus Communication Loss	No Modbus communication	Failed
Sensor Value out of Range	VelocityWarning	Offspec
Device not calibrated	NotCalibrated	Offspec
Sensor Measurement Error	SingleChAccuracy	Offspec
	MultiChAccuracy	Offspec
	ActiveTw	Offspec
	CycleSkip	Offspec
	Amplitude	Offspec
	SignalQuality	Offspec
	VelocityRange	Offspec
	SoundSpeed	Offspec
SNR	Offspec	
Device in Configuration Mode	In Configuration Mode - Indication	Check
Unsupported Parameter Warning	Unsupported Parameter - Warning	Check
Invalid Parameter Range Warning	Invalid Parameter Range - Warning	Check
Invalid Request Warning	Invalid request - Warning	Check
Invalid User Warning	Invalid User - Warning	Check

F.5 XMIT Transducer Block

The **XMIT** transducer block contains parameters that can be transmitted onto the Fieldbus via the **AI** block. The user can view real time data and select the units for each of the parameters (see *Figure 72* below).

The screenshot displays the configuration window for the XMIT transducer block. At the top, the title bar reads "BH_XMT1000___FBK2__152917551 : XMIT_TB" and "FBK2__152917551". Below the title bar is an "Apply Values" button. The main interface shows the block name "XMIT_TB" and address "FBK2__1529". There are several icons for configuration and monitoring. A "Periodic Updates" checkbox is checked, with a value of "2 (sec)". Below this, there are "OOS" and "Auto" buttons. A tabbed interface at the bottom includes "Process", "I/O Config", "Alarms", "Diagnostics", "Trends", and "Others". The "Process" tab is active, showing a table of parameters.

Parameter	Value	Type
<ul style="list-style-type: none"> ● DENSITY ├── VALUE └── STATUS <ul style="list-style-type: none"> ├── QUALITY ├── SUBSTATUS └── LIMITS 	1000 Good_NonCascade NonSpecific NotLimited	[Red Alarm Icon] [Unit Selection Icon] [Unit Selection Icon] [Unit Selection Icon]
● DENSITY_UNIT	kg/m ³	[Unit Selection Icon]
<ul style="list-style-type: none"> ● VOLUMETRIC_FLOW ├── VALUE └── STATUS <ul style="list-style-type: none"> ├── QUALITY ├── SUBSTATUS └── LIMITS 	0.008166 Good_NonCascade NonSpecific NotLimited	[Red Alarm Icon] [Unit Selection Icon] [Unit Selection Icon] [Unit Selection Icon]

Figure 72: Measurement Parameters and Units in XMIT Transducer Block

F.5.1 Units

The measurement parameters found on the **XMIT Transducer Block** have several selectable units. Table 38 below lists the available units for each parameter.

Note: *The units can only be changed using an **Admin** password. Make sure the selected units agree between the **XMIT Transducer Block** and the **AI Block**.*

Table 38: Available Parameters and Units in XMIT Transducer Block

Parameter	Units
Density	g/m ³ , kg/L, g/ml, kg/m ³ , lb/in ³ , lb/ft ³ , lb/gal
Volumetric Flow (Act)	m ³ /s, m ³ /m, m ³ /h, m ³ /d, L/s, L/min, L/h, ML/d, CFS, CFM, CFH, ft ³ /d, gal/s, GPM, gal/h, gal/d, ImpGal/s, ImpGal/min, ImpGal/h, ImpGal/d, bbl/s, bbl/min, bbl/h, bbl/d, kgal/min, kgal/h, kgal/d, kbbbl/min, kbbbl/h, kbbbl/d, ac-ft/m, ac-ft/h, ac-ft/d
Mass Flow	kg/s, kg/min, kg/h, kg/d, t/s, t/min, t/h, t/d, lb/s, lb/min, lb/h, lb/d, Ston/s, Ston/min, Ston/h, Ston/d, klb(US)/s, klb(US)/min, klb(US)/h, klb(US)/d
Velocity	m/s, ft/s
Totals	m ³ , L, ft ³ , gallon, bbl, Mgal, Mft ³ , ImpGal, Mbbbl, MI, Mm ³ , ac-ft, ac-in, Sm ³ , SL, SCF
Temperature	K, C, F, R
Pressure	kg-m ² , Pa, Mpa, kPa, bar, mbar, torr, atm, psia, psig

F.6 Composite Transducer Block

The **Composite Transducer Block** provides the *measurement values* and *programmable parameters* that are common to all three paths. *Figure 73* below shows the **Composite Transducer Block** and *Table 39* on page 114 lists the *Measurements* and *Parameters* that are available.

Note: The **R/W** designation means that the parameter is writable in **FF** using an **Admin** password.

Parameter	Value
● PIPE_ID	90.0023 mm
● PIPE_OD	110.002 mm
● PIPE_WALL_THICKNESS	10 mm
● CORR_PEAK_LOW_LIMIT	1000
● ANALOGOUT_PERCENTSCALE	0 %
● ACCELERATION_LIMIT	15 m/s ²
● AMP_DISC_MIN	14
● AMP_DISC_MAX	32

Figure 73: Composite Transducer Block

Table 39: Available Measurement Values and Parameters in the Composite TB

Composite TB Measurements and Parameters	Measurement	Parameter
BATCH_FWD_TOTALS	R	
BATCH_REV_TOTALS	R	
BATCH_TOTAL_TIME	R	
SOUND_SPEED	R	
INVENTORY_FWD_TOTALS	R	
INVENTORY_REV_TOTALS	R	
INVENTORY_TOTAL_TIME	R	
MULTI_KFACTOR	R	
REYNOLDS_KFACTOR	R	
CURRENT_OPERATING_TEMP	R	
STANDARD_VOLUMETRIC	R	
BATCH_NET_TOTALS	R	
ERROR_STATUS	R	
HEALTH_CODE	R	
REPORTED_ERROR	R	
GATE_INPUT_STATE	R	
UNIT_TYPE_DENSITY_R	R	
UNIT_TYPE_VELOCITY_R	R	
UNIT_TYPE_TEMPERATURE_R	R	
PIPE_ID		R/W
PIPE_OD		R/W
PIPE_WALL_THICKNESS		R/W
CORR_PEAK_LOW_LIMIT		R/W
ANALOGOUT_PERCENTSCALE		R/W
ACCELERATION_LIMIT		R/W
AMP_DISC_MIN		R/W
AMP_DISC_MAX		R/W
KINEMATIC_VISCOSITY		R/W
CALIBRATION_FACTOR		R/W
ZERO_CUTOFF		R/W
RESPONSE_TIME		R/W
VELOCITY_LOW_LIMIT		R/W
VELOCITY_HIGH_LIMIT		R/W
VELOCITY_WARN_LOW_LIMIT		R/W
VELOCITY_WARN_HIGH_LIMIT		R/W
REFERENCE_DENSITY		R/W
SOS_LOW_LIMIT, SOS_HIGH_LIMIT		R/W
MULTIK_VELREY_1-12, MULTIK_KFACTOR_1-12		R/W
REYNOLDS_CORRECTION		R/W
FLUID_SUPPLY_TEMPERATURE		R
FLUID_RETURN_TEMPERATURE		R

Table 39: Available Measurement Values and Parameters in the Composite TB

Composite TB Measurements and Parameters	Measurement	Parameter
SOS_LOW_LIMIT		R/W
SOS_HIGH_LIMIT		R/W
MULTIK_VELREY		R/W
MULTIK_KFACTOR		R/W
PATHCONFIGURATION		R/W
HARDWARE_REVISION		R
SOFTWARE_REVISION		R
UMPU_SERIAL_NUMBER		R
TOTALIZER_CMD		R/W
SENSOR_SERIAL_NUMBER		R
MULTIK_ACTIVE		R/W
MULTIK_TYPE		R/W
MULTIK_PAIRS		R/W
KVINPUT_SELECTION		R/W
ENABLE_ACTIVE_TW		R/W
CALIBR_MODE_SELECTION		R/W
PATH_ERROR_HANDLING		R/W
UNIT_TYPE_DIMENSION		R/W
UNIT_TYPE_TIME		R/W
UNIT_TYPE_VISCOSITY		R/W
UNIT_TYPE_STD_VOL		R/W
SYSTEM_SERIAL_NUMBER		R
FTPA_SERIAL_NUMBER		R
VOLTAGE_SELECTION		R/W
ATTENUATOR_SELECTION		R/W

F.6.1 Clearing the Totalizer

Batch totals can be controlled through Foundation Fieldbus (see *Figure 74* below). The user can start, stop, or reset batch totalizers by setting the option on the **TOTALIZER_CMD** function of the **Composite Transducer Block**. To set the totalizers from the Foundation Fieldbus:

1. Verify that the gate and ground terminals on the Main PCB are connected.
2. Program the **CALIBR_MODE_SELECTION** parameter on the **Composite Transducer Block** to **Gate Input**. After these steps are complete, you can control the batch totalizer (start, stop, or reset) by selecting the desired option on **TOTALIZER_CMD** and writing the changes to the meter. No password is required for this function.

IMPORTANT: *The Inventory Totalizer can only be reset at the factory.*

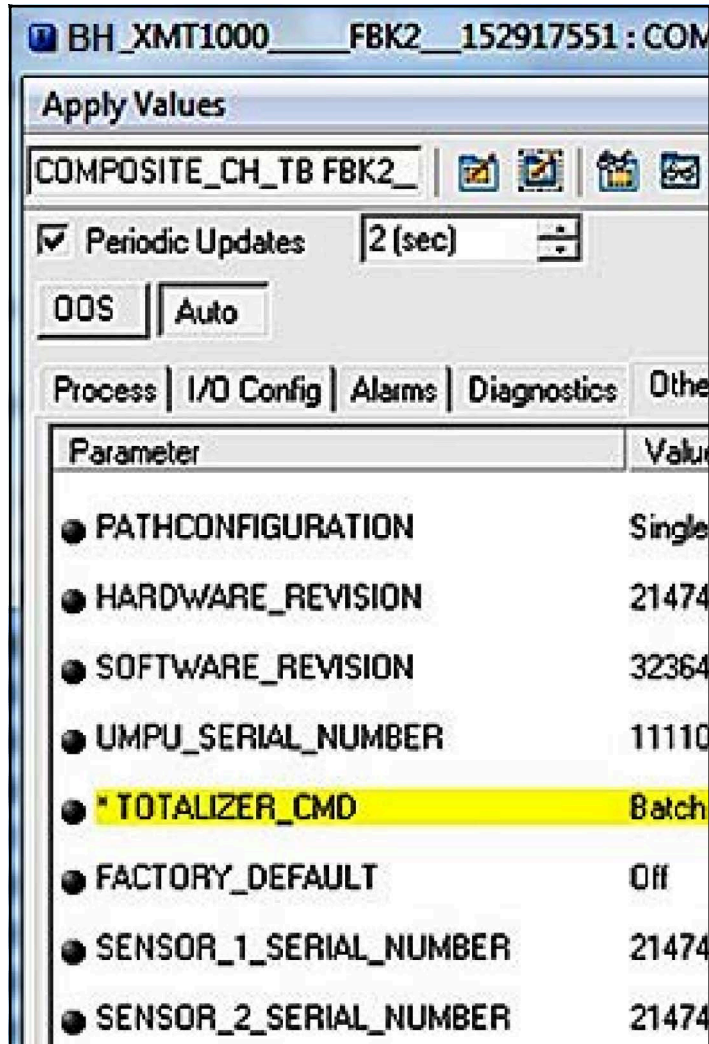

Figure 74: TOTALIZER_CMD Function on Composite TB

F.7 Configurable Measurements

Below table shows the measurements available over FF:

Table 40: Measurements Available Over FF

Velocity	Ch 1 Signal Quality Down	Ch 2 SNR Down
Volumetric	Ch 1 Amplitude Up	Ch 2 Peak Index Up
Mass Flow	Ch 1 Amplitude Down	Ch 2 Peak Index Down
Batch Fwd Volumetric Totals	Ch 1 Gain Up	Ch 2 Peak % Up
Batch Rev Volumetric Totals	Ch 1 Gain Down	Ch 2 Peak % Down
Totalizer Elapsed Time	Ch 1 SNR Up	Ch 2 No. Of Errors
Soundspeed	Ch 1 SNR Down	Ch 3 Soundspeed
Inventory Fwd Volumetric Totals	Ch 1 Peak Index Up	Ch 3 Transit Time Up
Inventory Rev Volumetric Totals	Ch 1 Peak Index Down	Ch 3 Transit Time Down
Inventory Totalizer Elapsed Time	Ch 1 Peak % Up	Ch 3 DeltaT
Meter Factor	Ch 1 Peak % Down	Ch 3 Signal Quality Up
Reynolds K-Factor	Ch 1 No. Of Errors	Ch 3 Signal Quality Down
Current Operating Temperature	Ch 2 Soundspeed	Ch 3 Amplitude Up
Standard Volumetric	Ch 2 Transit Time Up	Ch 3 Amplitude Down
Batch Net Volumetric Totals	Ch 2 Transit Time Down	Ch 3 Gain Up
Error Status	Ch 2 DeltaT	Ch 3 Gain Down
Health Code (All System Errors bit map)	Ch 2 Signal Quality Up	Ch 3 SNR Up
Reported Error (highest priority Error)	Ch 2 Signal Quality Down	Ch 3 SNR Down
Gate State	Ch 2 Amplitude Up	Ch 3 Peak Index Up
Ch 1 Soundspeed	Ch 2 Amplitude Down	Ch 3 Peak Index Down
Ch 1 Transit Time Up	Ch 2 Gain Up	Ch 3 Peak % Up
Ch 1 Transit Time Down	Ch 2 Gain Down	Ch 3 Peak % Down
Ch 1 DeltaT	Ch 2 SNR Up	Ch 3 No. Of Errors
Ch 1 Signal Quality Up		
Meter Information		
System Serial number	Sensor 2 Up Serial number	Buffer 1 Dn Serial number
Flow board Serial number	Sensor 2 Dn Serial number	Buffer 2 Up Serial number
Flow board hardware revision	Sensor 3 Up Serial number	Buffer 2 Dn Serial number
Sensor 1 Up Serial number	Sensor 3 Dn Serial number	Buffer 3 Up Serial number
Sensor 1 Dn Serial number	Buffer 1 Up Serial number	Buffer 3 Dn Serial number

Table 41: Configurable through FF

Pipe Configurations	Pipe Outer Diameter
	Pipe Wall Thickness
	Pipe Inner Diameter
Fluid Configurations	Kinematic Viscosity
	Reference Density
	Tracking Mode Selection
	Minimum Soundspeed
	Maximum Soundspeed
Limits	Minimum Velocity Warning Limit
	Maximum Velocity Warning Limit
	Minimum Velocity
	Maximum Velocity
	Zero Cutoff
	Flow Averaging
	Minimum Amplitude
	Maximum Amplitude
	Correlation Peak Limit
Path Configuration	Path Configuration
	Path Error Handling
	Ch 1 Path Weight
	Ch 2 Path Weight
	Ch 3 Path Weight
	Ch 1 Path Length
	Ch 2 Path Length
	Ch 3 Path Length
	Ch 1 Axial Length
	Ch 2 Axial Length
	Ch 3 Axial Length
Transducer Configurations	Ch 1 Transducer Type
	Ch 1 Transducer Number
	Ch 1 Transducer Frequency
	Ch 1 Static Tw
	Ch 2 Transducer Type
	Ch 2 Transducer Number
	Ch 2 Transducer Frequency
	Ch 2 Static Tw
	Ch 3 Transducer Type
	Ch 3 Transducer Number
	Ch 3 Transducer Frequency
	Ch 3 Static Tw

Table 41: Configurable through FF

Advanced	Transmit Voltage
	Attenuator
	Reynolds Correction
	Tw Mode Selection
	Ch 1 Active Tw Peak %
	Ch 2 Active Tw Peak %
	Ch 3 Active Tw Peak %
	Ch 1 Delta-T Offset
	Ch 1 Tbc
	Ch 1 Transmit Delay
	Ch 1 Number of Errors Allowed
	Ch 1 Peak %
	Ch 2 Delta-T Offset
	Ch 2 Tbc
	Ch 2 Transmit Delay
	Ch 2 Number of Errors Allowed
	Ch 2 Peak %
	Ch 3 Delta-T Offset
	Ch 3 Tbc
	Ch 3 Transmit Delay
Ch 3 Number of Errors Allowed	
Ch 3 Peak %	
Calibration	Meter Factor
	Calibration Mode Selection
	K-Table Selection
	Number of Points
	Calibration Type Selection
Calibration table	Velocity points (1 to 6)
	Reynolds points (1 to 6)
	K-Factors points (1 to 6)

F.8 Channel Transducer Block

The **CH1**, **CH2** and **CH3** transducer blocks show the *measurement values* and *programmable parameters* for each of the three paths. *Figure 75* below shows the **Channel Transducer Block**, and *Table 42* on page 121 lists the *measurements* and *parameters* that are available.

Note: The **R/W** designation means that the parameter is writable in **FF** using an **Admin** password.

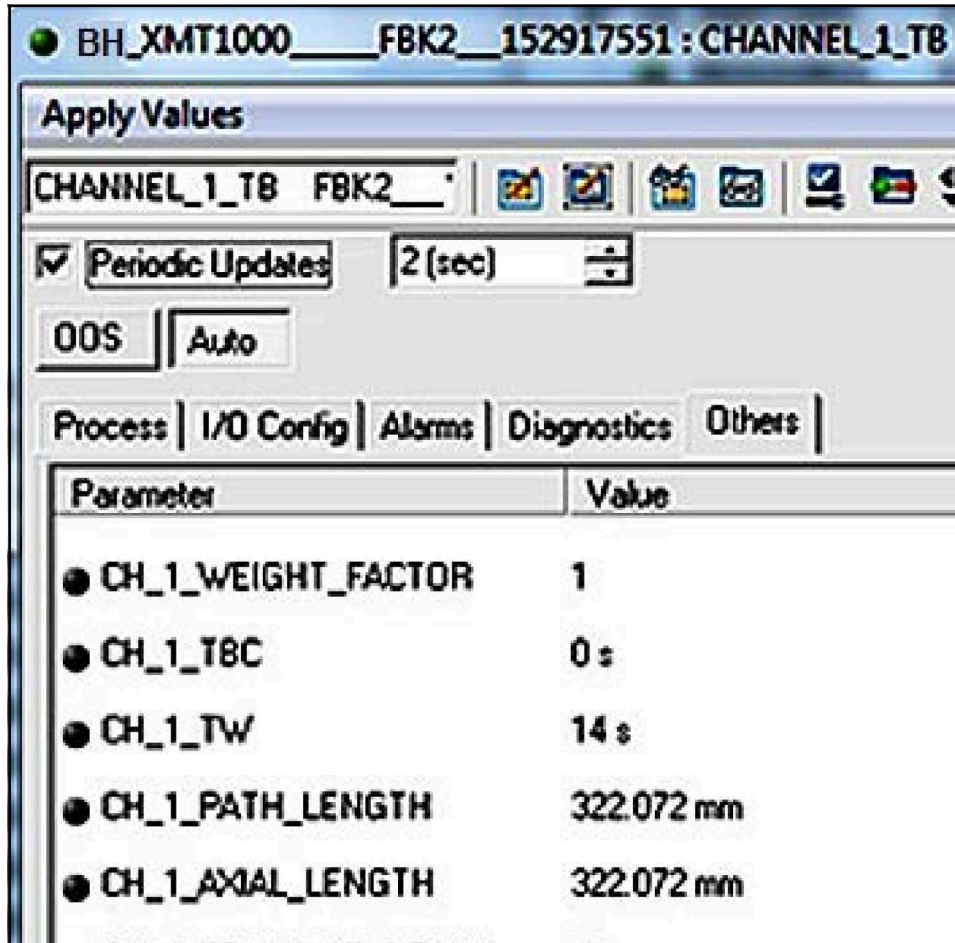

Figure 75: Channel Transducer Block

Table 42: Available Measurement Values and Parameters in the Channel TB

Channel TB Measurements and Parameters	Measurement	Parameter
CH_SOUND_SPEED	R	
CH_TRANSIT_TIME_UP	R	
CH_TRANSIT_TIME_DN	R	
CH_DELTA_T	R	
CH_UP_SIGNAL_QUALITY	R	
CH_DN_SIGNAL_QUALITY	R	
CH_UP_AMP_DISC	R	
CH_DN_AMP_DISC	R	
CH_GAIN_UP	R	
CH_GAIN_DN	R	
CH_SNR_UP	R	
CH_SNR_DN	R	
CH_UP_PEAK	R	
CH_DN_PEAK	R	
CH_PEAK_PCT_UP	R	
CH_PEAK_PCT_DN	R	
CH_NUM_ERRORS_OF_16	R	
CH_WEIGHT_FACTOR		R/W
CH_TBC		R/W
CH_TW		R/W
CH_PATH_LENGTH		R/W
CH_AXIAL_LENGTH		R/W
CH_TRANSMIT_DELAY		R/W
CH_DELTA_T_OFFSET		R/W
CH_PCT_PEAK		R/W
CH_TRANSDUCER_TYPE		R/W
CH_TRANSDUCER_FREQ		R/W
CH_ERRORS_ALLOWED		R/W
CH_TRANSDUCER_NUMBER		R/W
CH_PATHCONFIGURATION		R/W

F.9 Analog Input Block

The Analog Input (**AI**) Block (see *Figure 76* below) is designed as a generalized signal conditioning function. The output from an **AI** block can be connected to the Fieldbus. The **AI** block receives and processes data measured by the **Transducer Block** and provides additional functions such as scaling, filtering, alarm generation, and trending.



Figure 76: Analog Input (AI) Block

F.10 PID Block

The **PID** function offers control based on a programmable algorithm. The **PID** function block may be used with a valve to control flow.

Note: See Foundation Fieldbus Specifications for more detail on use of the **PID** Block.

F.11 Error Handling

The flow meter publishes the error status on the Fieldbus along with the real data. The *error status* can be seen in the **CH_x_Reported Error** parameter on the **Channel Transducer Block**. In addition, the **Quality** parameter shown with each of the process variables reports the error. In *Figure 77* below, the **CH1_REPORTED_ERROR** shows as **E1**.

Note: For more information on the actual measurement errors and possible causes, see Chapter 4, Error Codes and Troubleshooting.

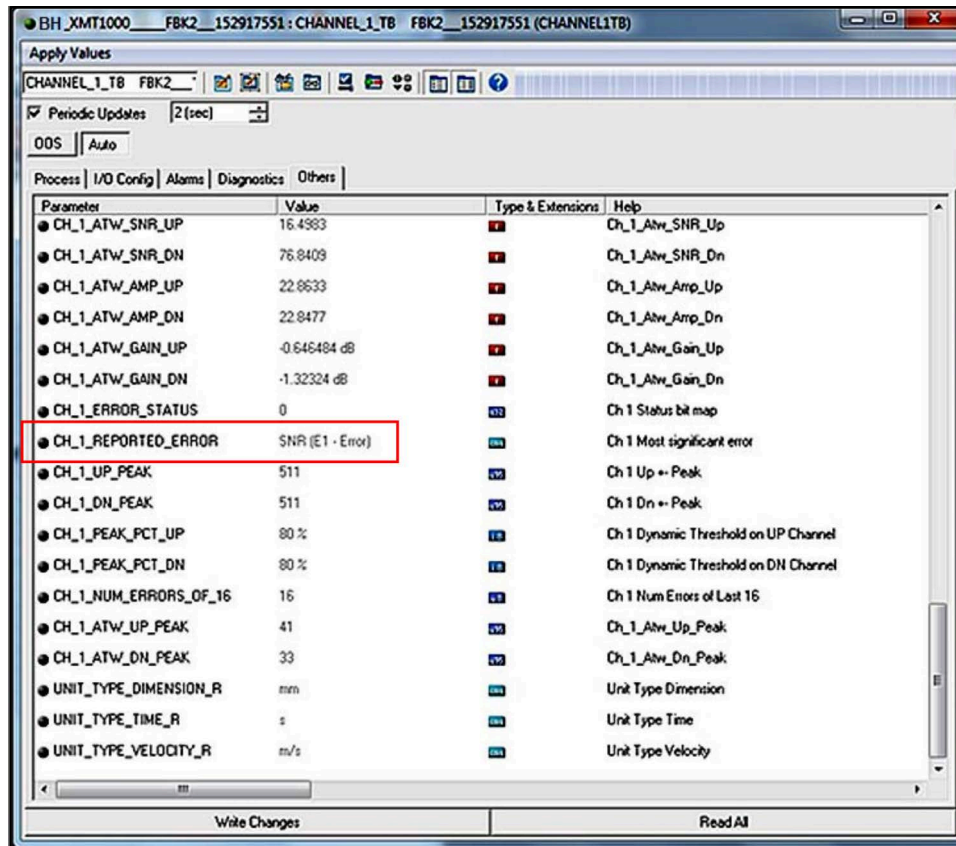

Figure 77: Reported Error

Whenever the meter is in measurement error, the *quality bit* for the published parameter shows *bad quality* (see Figure 78 below). To change the quality bit to *good*, the measurement error at the meter must be removed.

Notice the **QUALITY.STATUS** field shows as **Bad** and the **SUBSTATUS** field shows as **Sensor Failure**. This information indicates a measurement error which must be corrected.

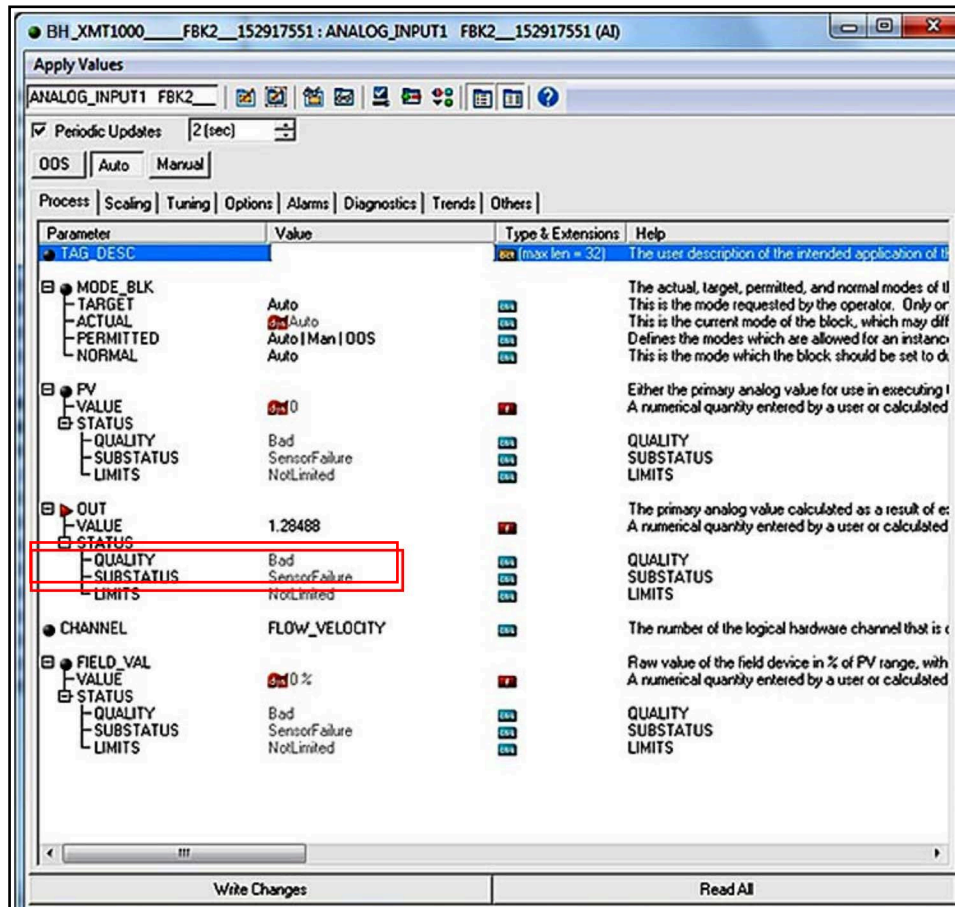

Figure 78: Quality Bit Error

F.12 Simulation Mode

Simulation mode allows the user to test the FF implementation without the instrument providing real data. The meter PCB is shipped with simulation mode disabled. To enable simulation mode, complete the following steps:



CAUTION! To prevent damage to the electronic components, always use ESD protection whenever handling printed circuit boards.

1. Remove the PCB from the meter.
2. Locate the jumper **P5** (see *Figure 79* below).
3. Move the **P5** jumper to the left one place (pins 2 & 3) to enable simulation mode.
4. Re-install the PCB into meter
5. Verify that the **Block** error field in the **Resource Block** shows *SimulationActive* status.

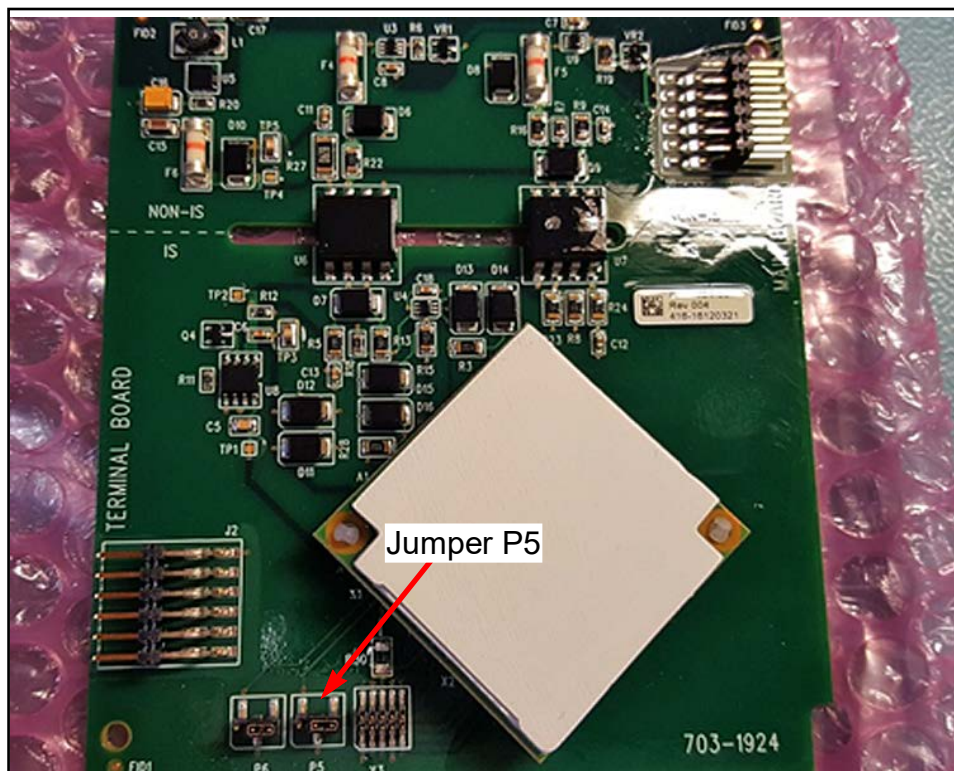

Figure 79: P5 on XMT1000 PCB

F.13 Fieldbus Troubleshooting Guide

See Table 43 below for suggested solution to possible Fieldbus problems.



Table 43: XMT1000 FF Troubleshooting Guide

Problem	Presumed Cause	Remedy
Communication between DCS and XMT1000 FF cannot be established	Wiring unconnected, broken or shorted	Correct wiring between XMT1000 and spur device coupler.
	The power is off or the power supply voltage is less than 9 V	Supply proper voltage
	The address detection range is not correctly set in the DCS	Correct address detection range - default address for XMT1000 is 0x17
Communication with the XMT1000 FF is frequently cut off.	The fieldbus is experiencing a large amount of noise.	Using an oscilloscope or another fieldbus health monitor to check the waveform on the fieldbus.
	Missing terminators on the bus, incorrect terminator placement or extra terminators.	Refer to FOUNDATION Fieldbus specifications for a full discussion of terminator requirements.
A value cannot be written to a parameter in the XMT1000 FF.	Not in configuration mode.	Enter correct "Admin" password in Resource block - verify "S1 - configuration mode" appears on XMT1000 UI
	You have attempted to write a value outside the valid range.	Check the setting range of parameters.
	The present mode does not allow write access.	Change the target mode.
	The jumper is in write protected configuration.	Contact factory for write protect jumper configuration
The actual mode of a function block differs from the target mode.	Resource block in OOS.	Change the target mode of the Resource Block to Auto.
	Schedules that define when function blocks execute are not set correctly.	Set the schedules using a configuration tool.
	The transducer block is not in Auto mode.	Change the target mode of the transducer block to Auto.
A block's dynamic parameters do not update.	XMT1000 is powered down	Verify the XMT1000 is powered on and measuring properly
	XMT1000 does not recognize the FF PCB	Check Options menu on XMT1000 UI for Fieldbus option - if it appears the meter knows it is present

F.14 DPI620 FF Modular Communicator

For local diagnostic capability with the XMT1000 FF option, Panametrics Measurement and Control recommends the **DPI620G-FF Genii** advanced modular calibrator and HART/Fieldbus communicator. The calibrator is available in an IS version as well (**DPI620G-IS-FF**). Table 44 below lists the models, description and key benefits.

Table 44: DPI620 Genii Models

Image	Model PN	Description	Key Benefits
	DPI620G-FF	Genii advanced modular calibrator and HART/Fieldbus communicator	<ul style="list-style-type: none"> Fully featured communicators for device configuration, trimming and calibration Complete device description (DD) libraries Internal power hub Free software and DD updates via simple web download
	DPI620G-IS-FF	Genii intrinsically safe advanced modular calibrator and HART/Fieldbus communicator	



Attention: For more information, see the **DPI620** website:
<https://www.bakerhughes.com/druck/test-and-calibration-instrumentation/multifunction-calibrators-2/dpi620g-modular-multifunction-calibrator>

[no content intended for this page]

Appendix G. Menu Map

G.1 Primary Pages – SIL Type

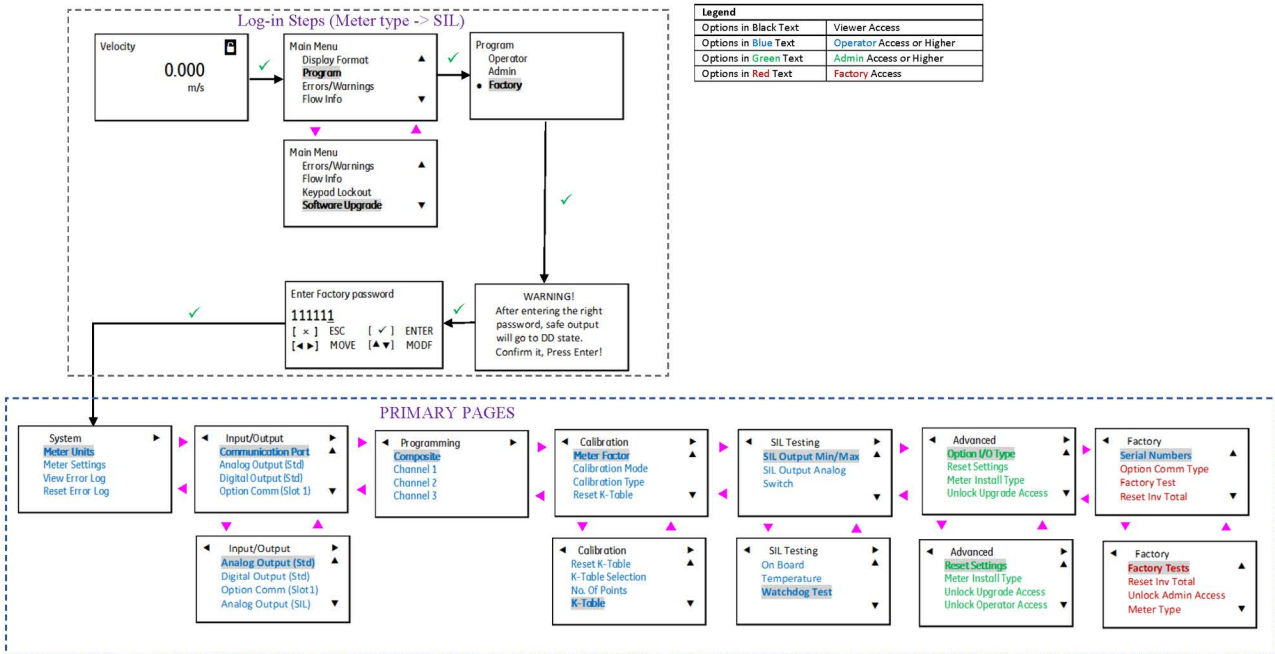

G.2 Primary Pages – Non-SIL Type

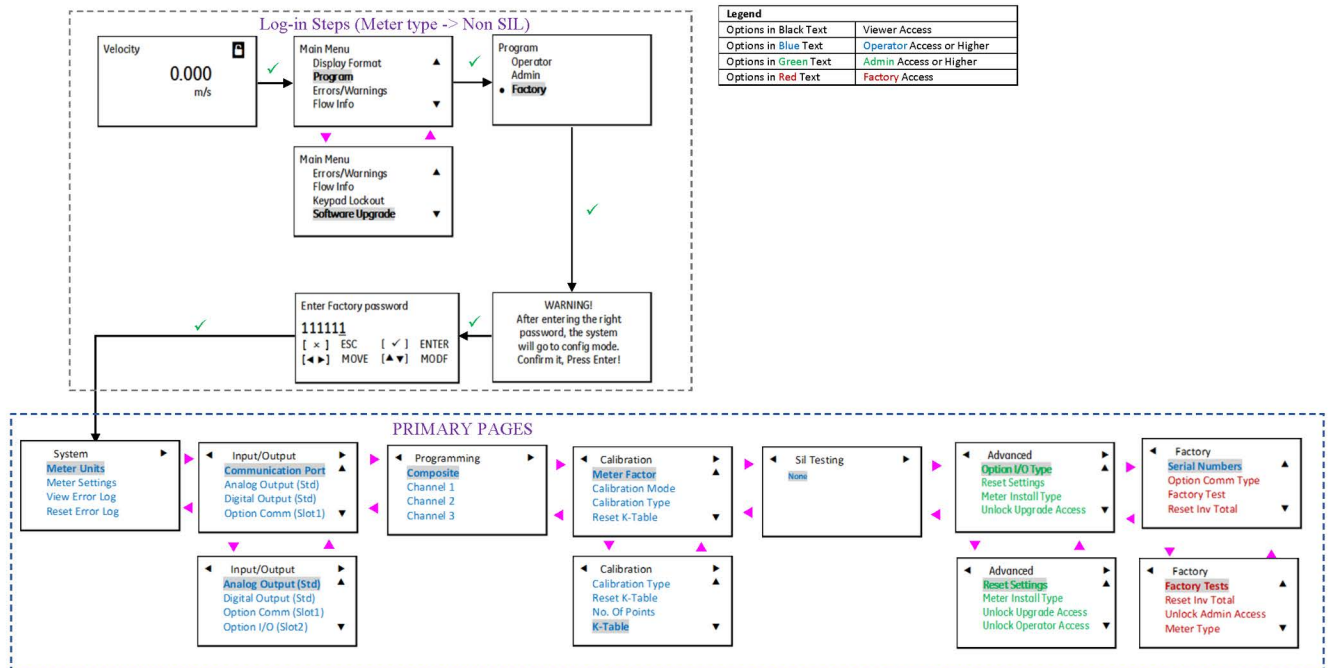

G.3 Log-in Steps - SIL Type

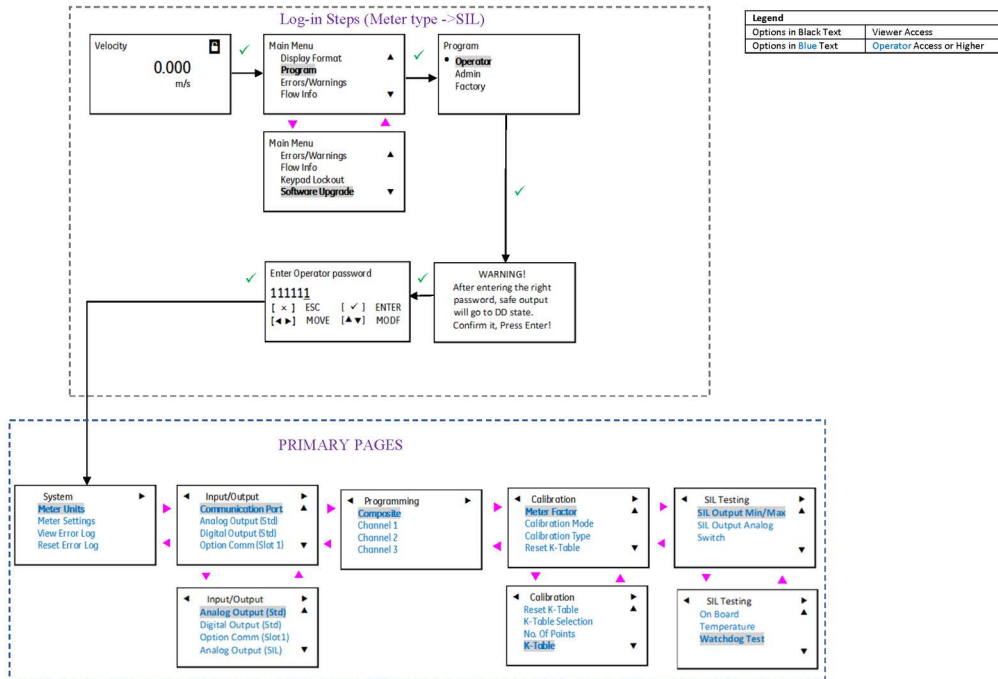

G.4 Log-in Steps - Non-SIL Type

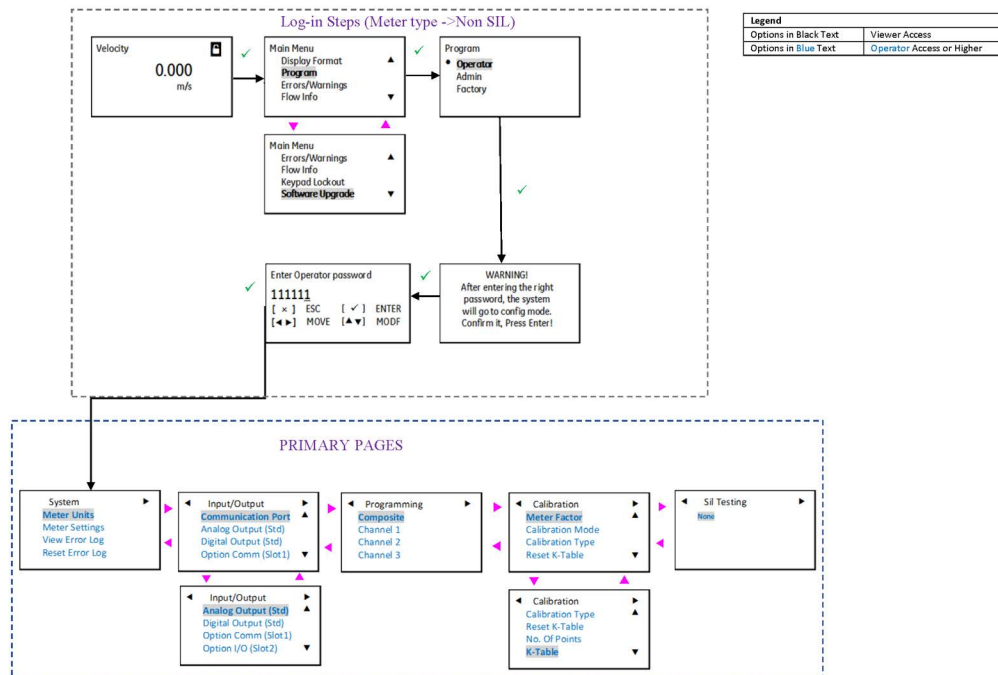

G.5 Meter Units and Settings

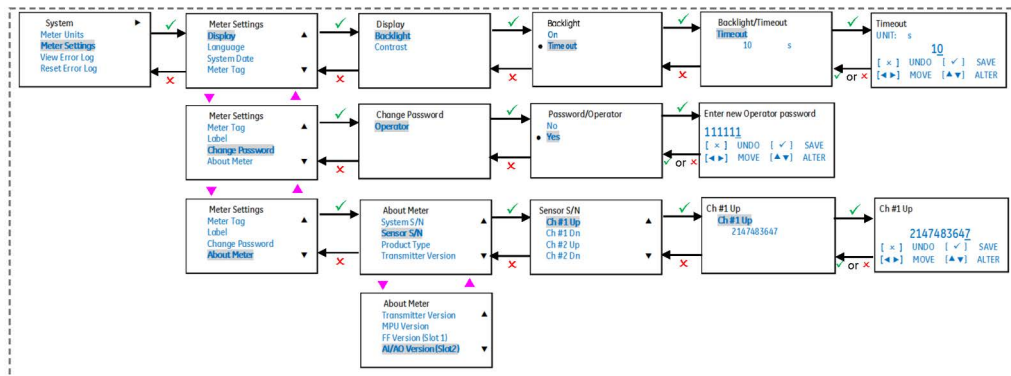
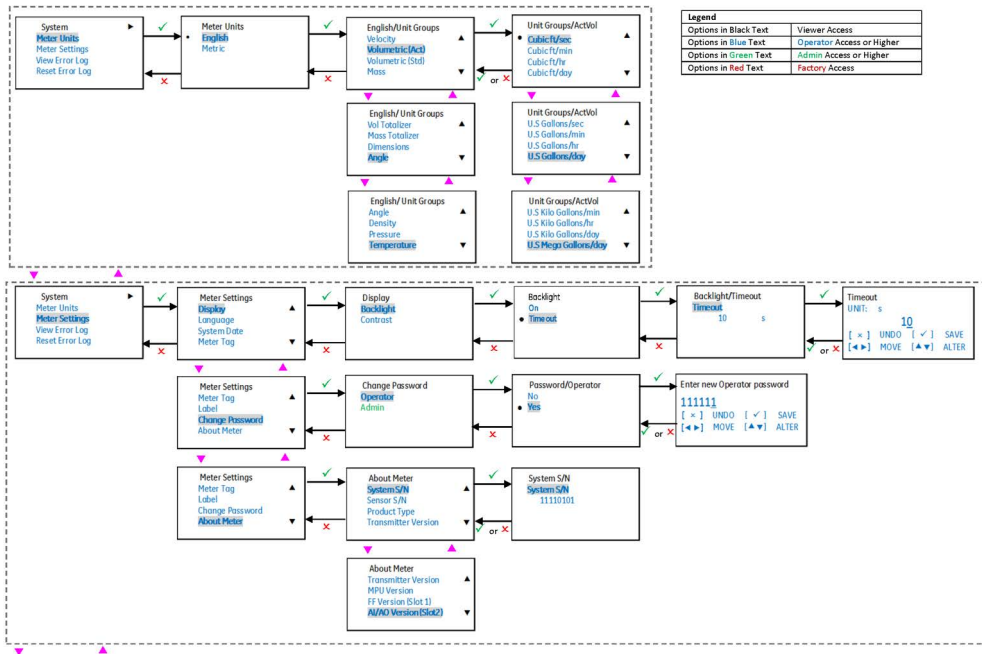

G.6 Error Log



G.7 Input/Output – Analog Output

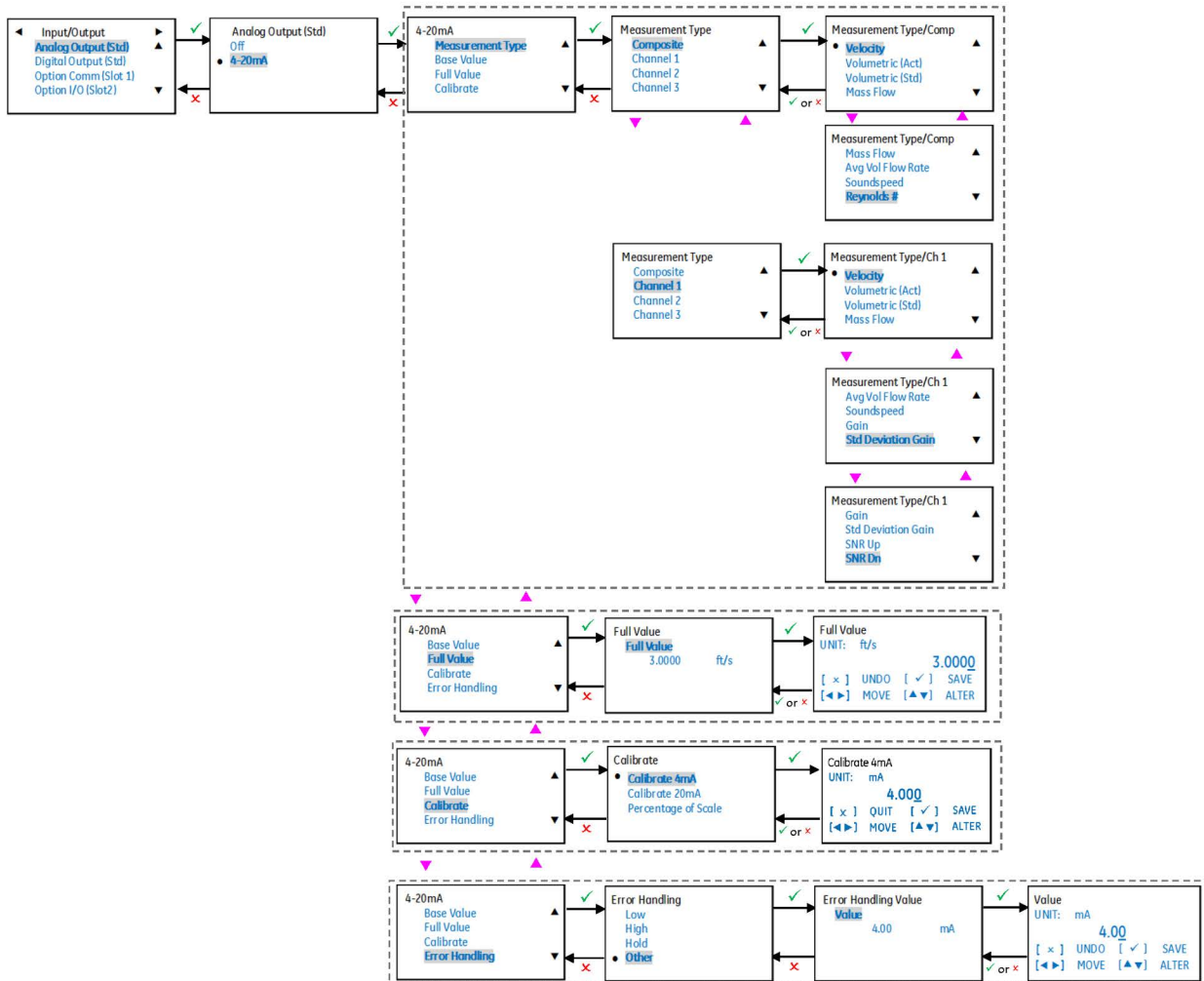

G.8 Digital Output – Pulse Output

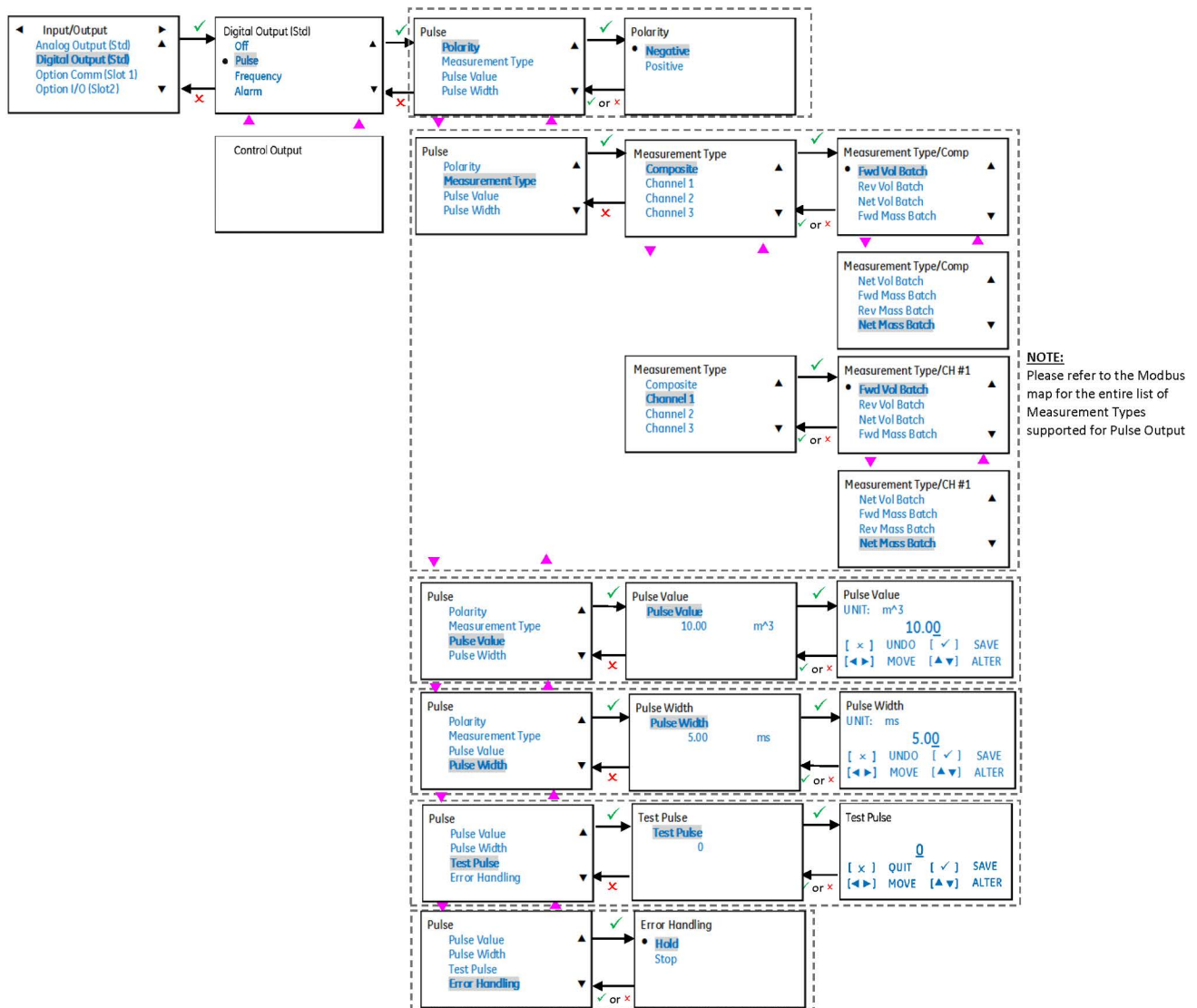

G.9 Digital Output – Frequency Output

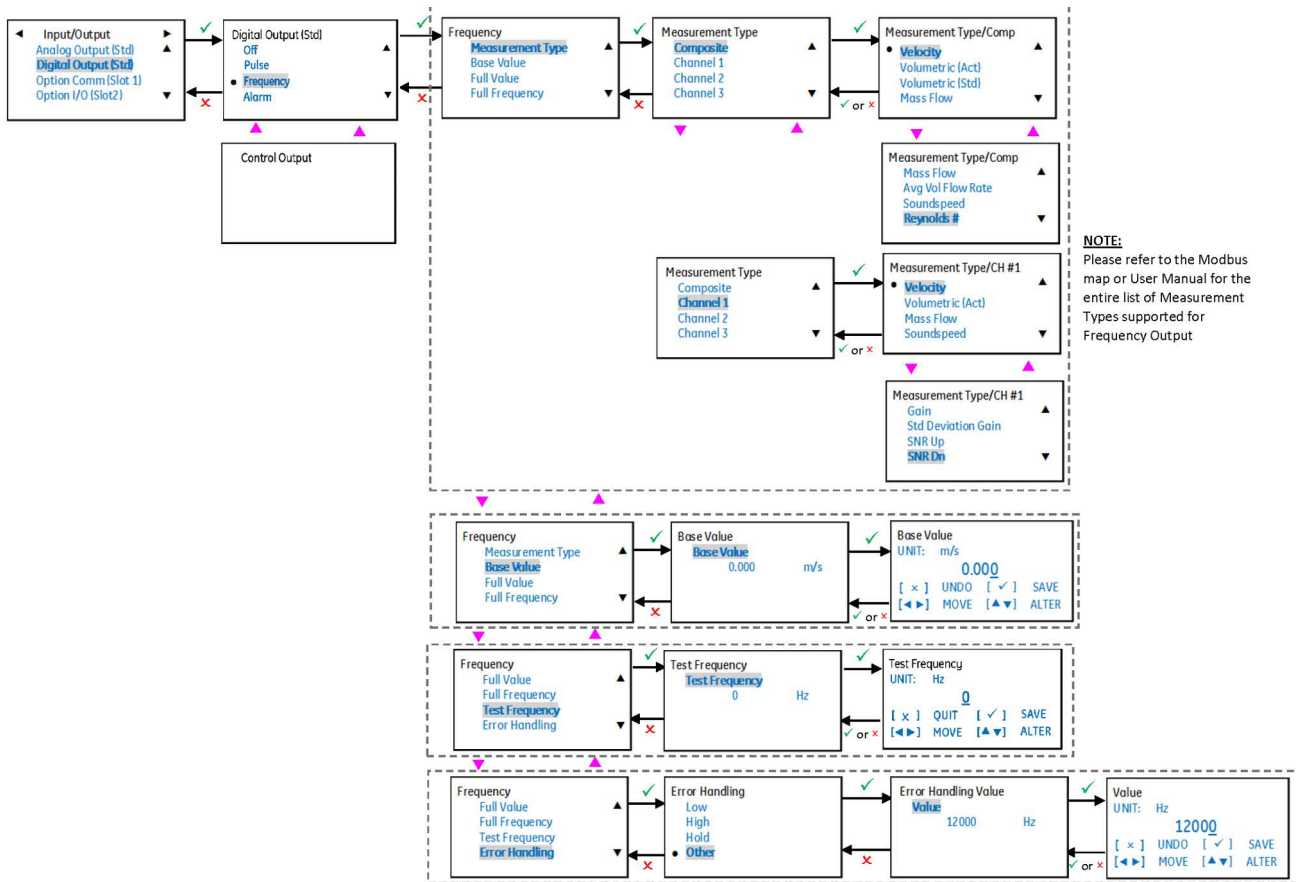

G.10 Digital Output - Alarm

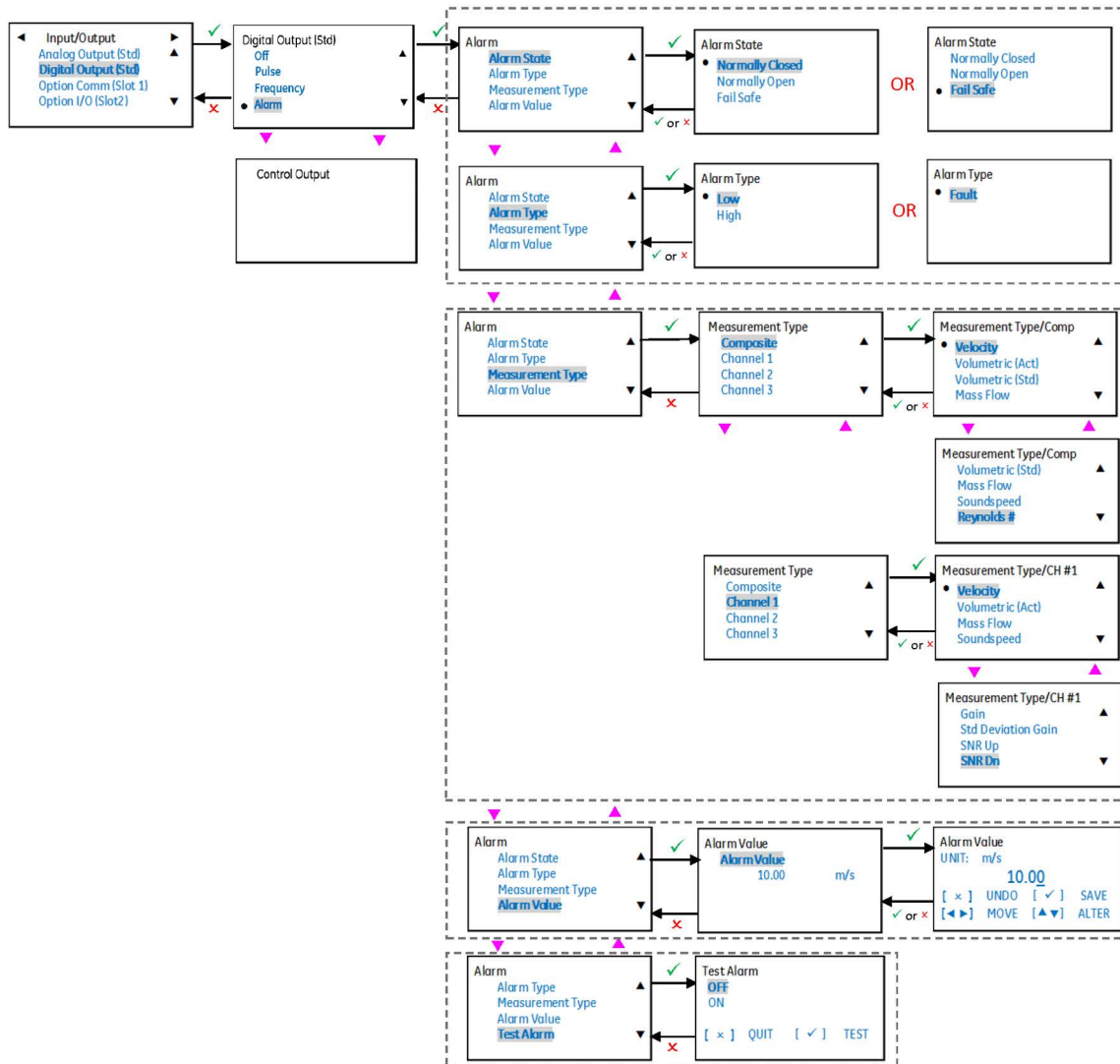

NOTE:
Please refer to the Modbus map for the entire list of Measurement Types supported for Alarms

G.11 Communication Port

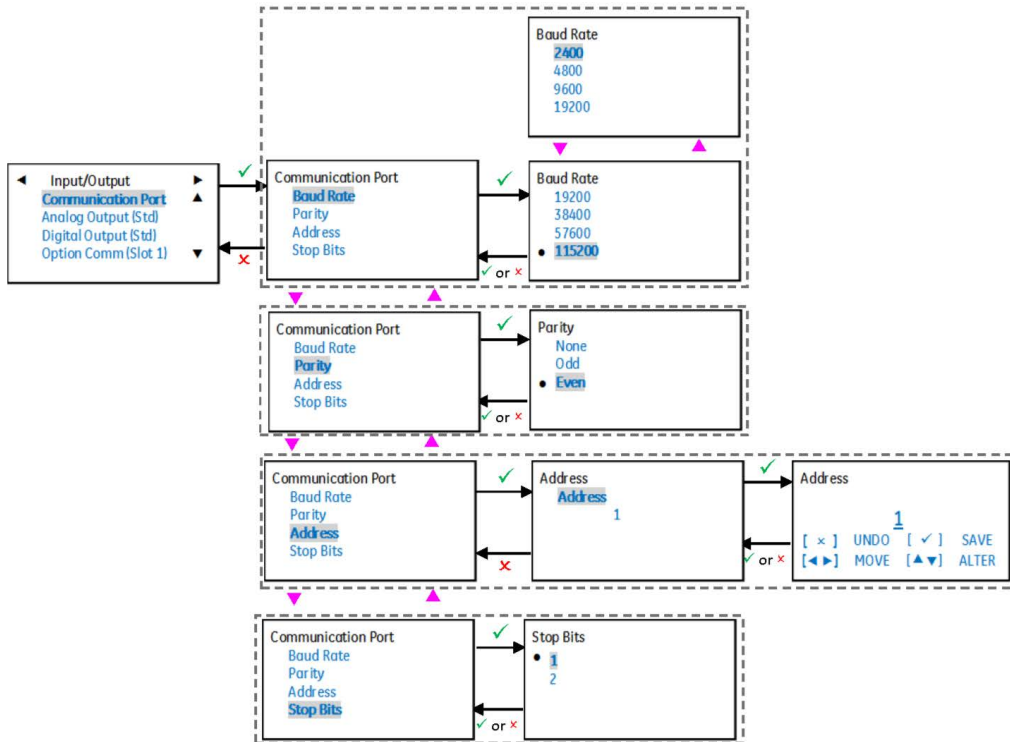

G.12 Input/Output - Option Comm (Slot 1)

G.12.1 FF

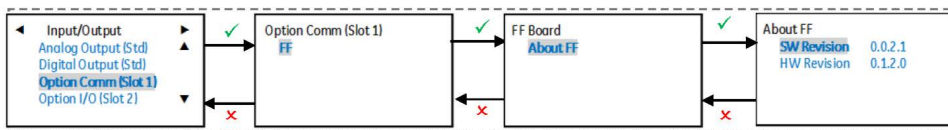

G.12.2 HART (PV Configuration)

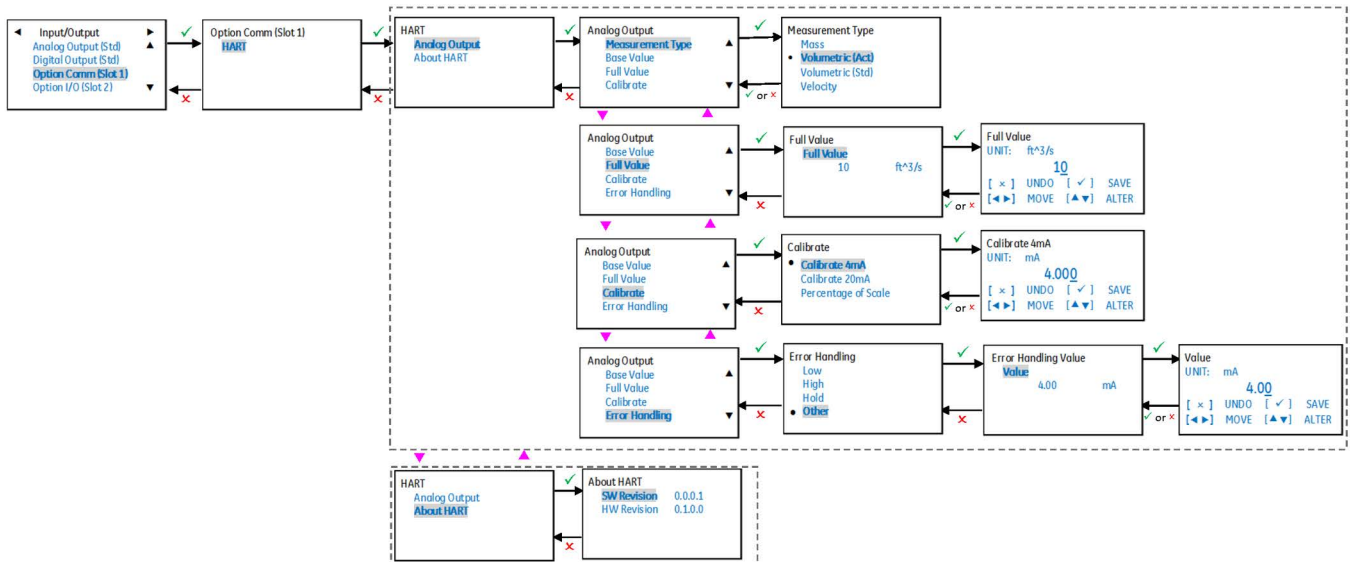

G.13 Programming

G.13.1 Composite Clamp-on (Pipe Configuration)

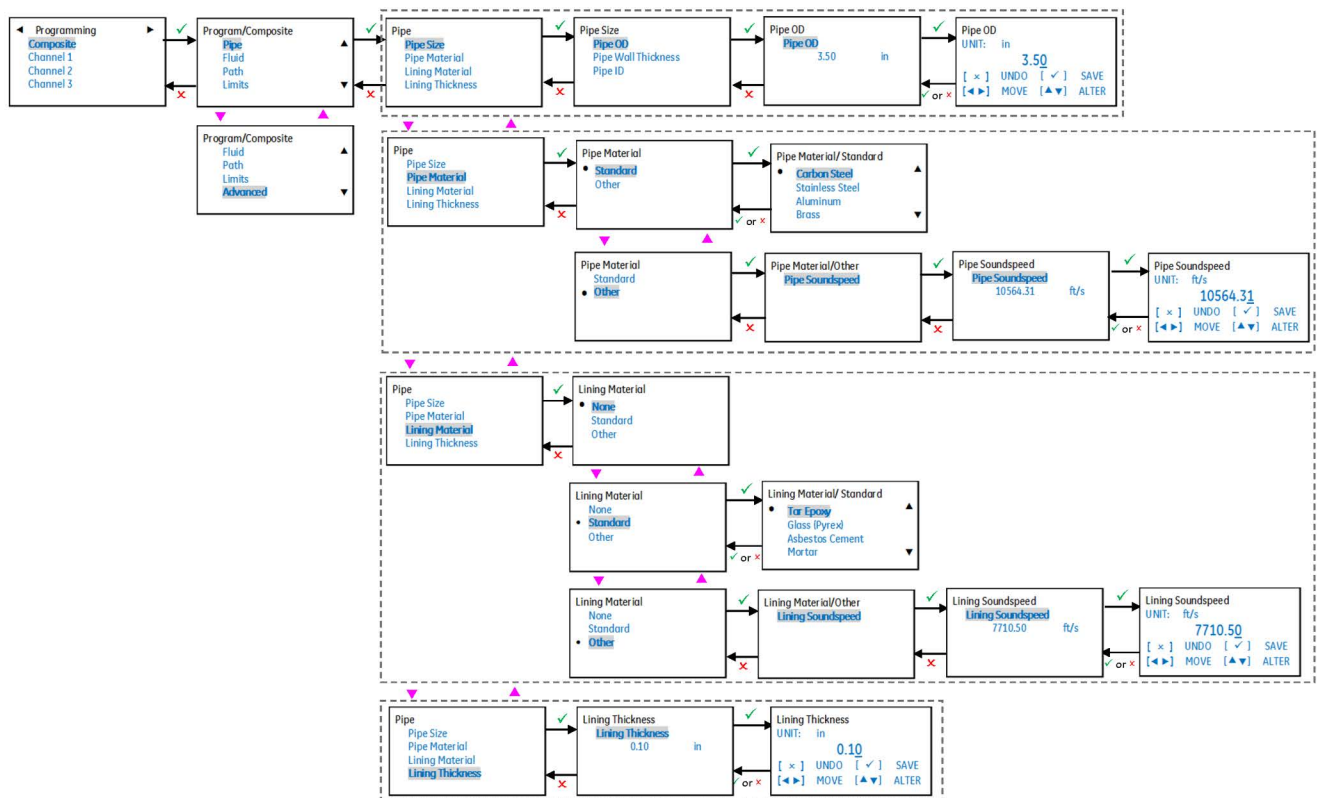

G.13.2 Composite Wetted (Pipe Configuration)

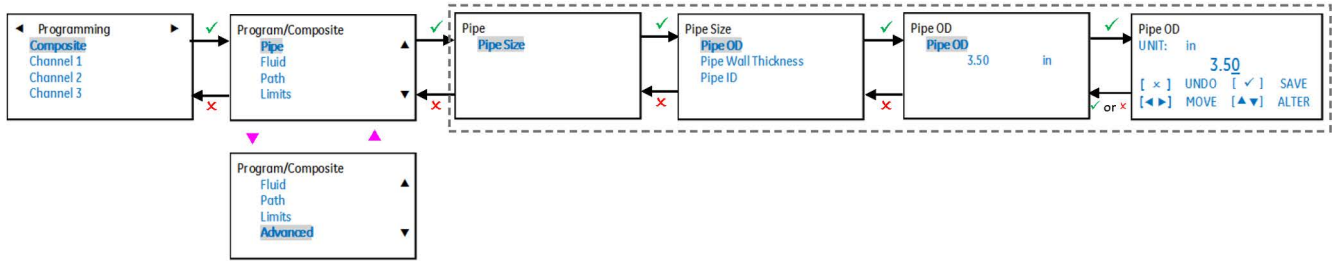

G.13.3 Composite Clamp-on and Wetted (Fluid)

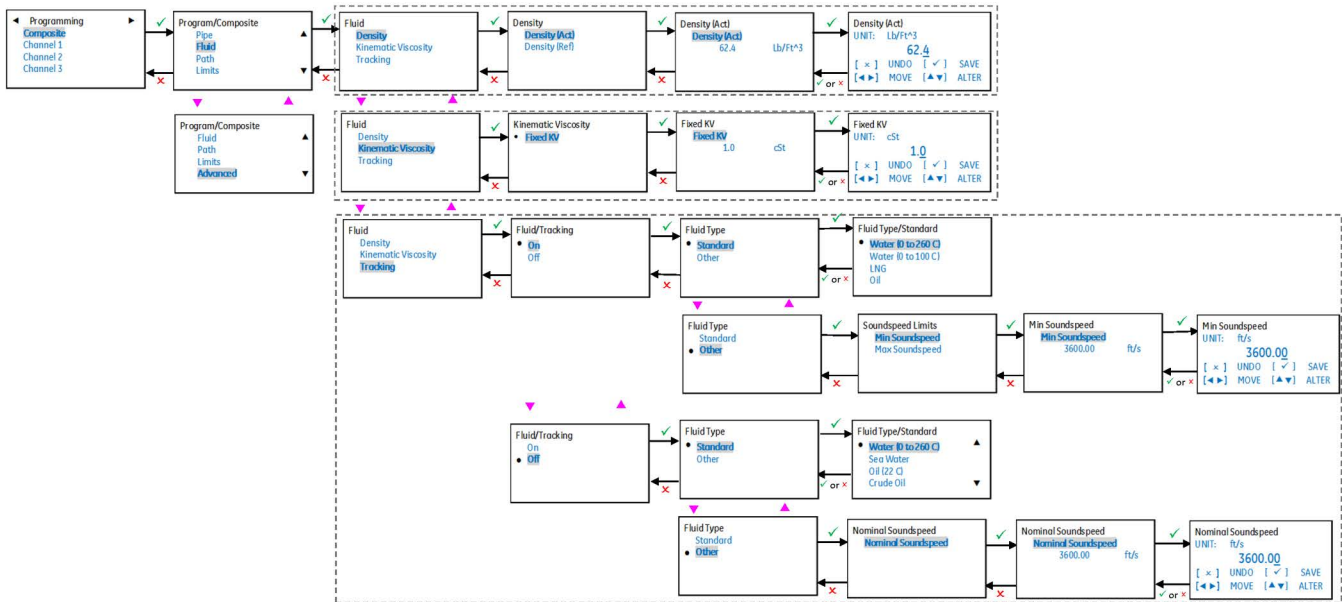

G.13.4 Composite - Path Configuration

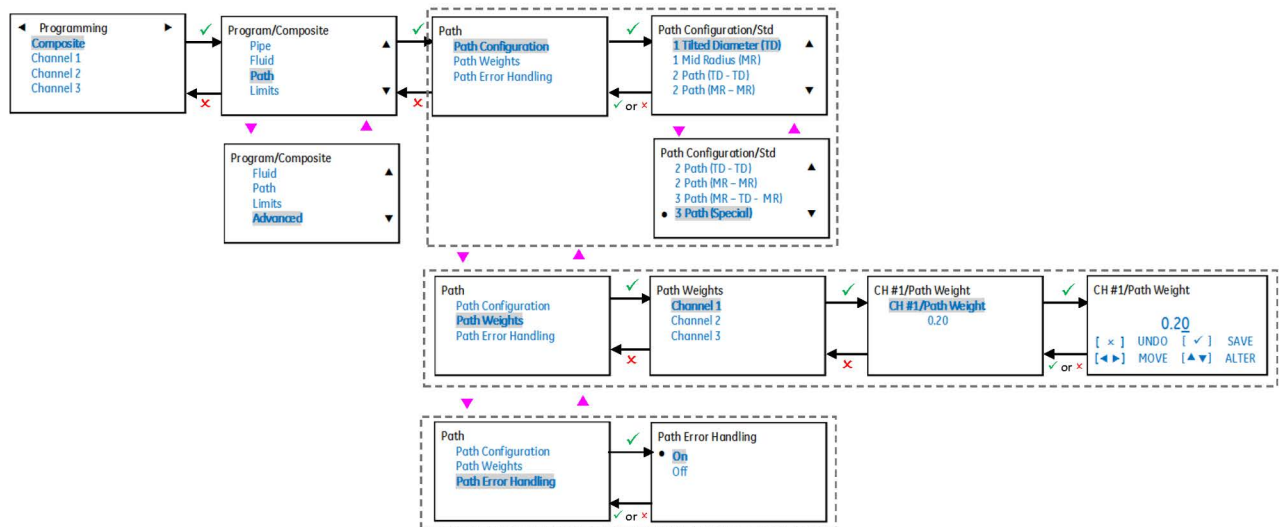

Programming - Composite Clamp-on (Path Configuration)

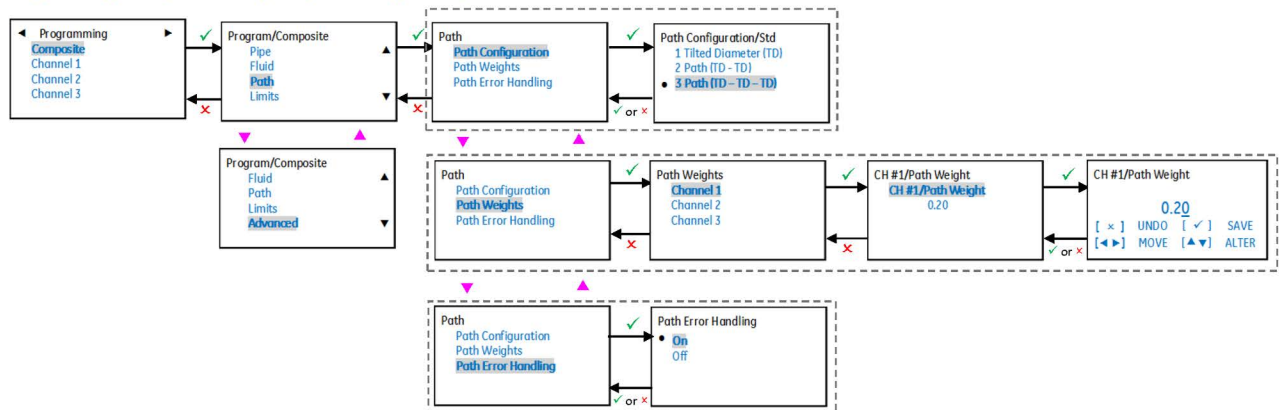

G.13.5 Composite (Limits Configuration)

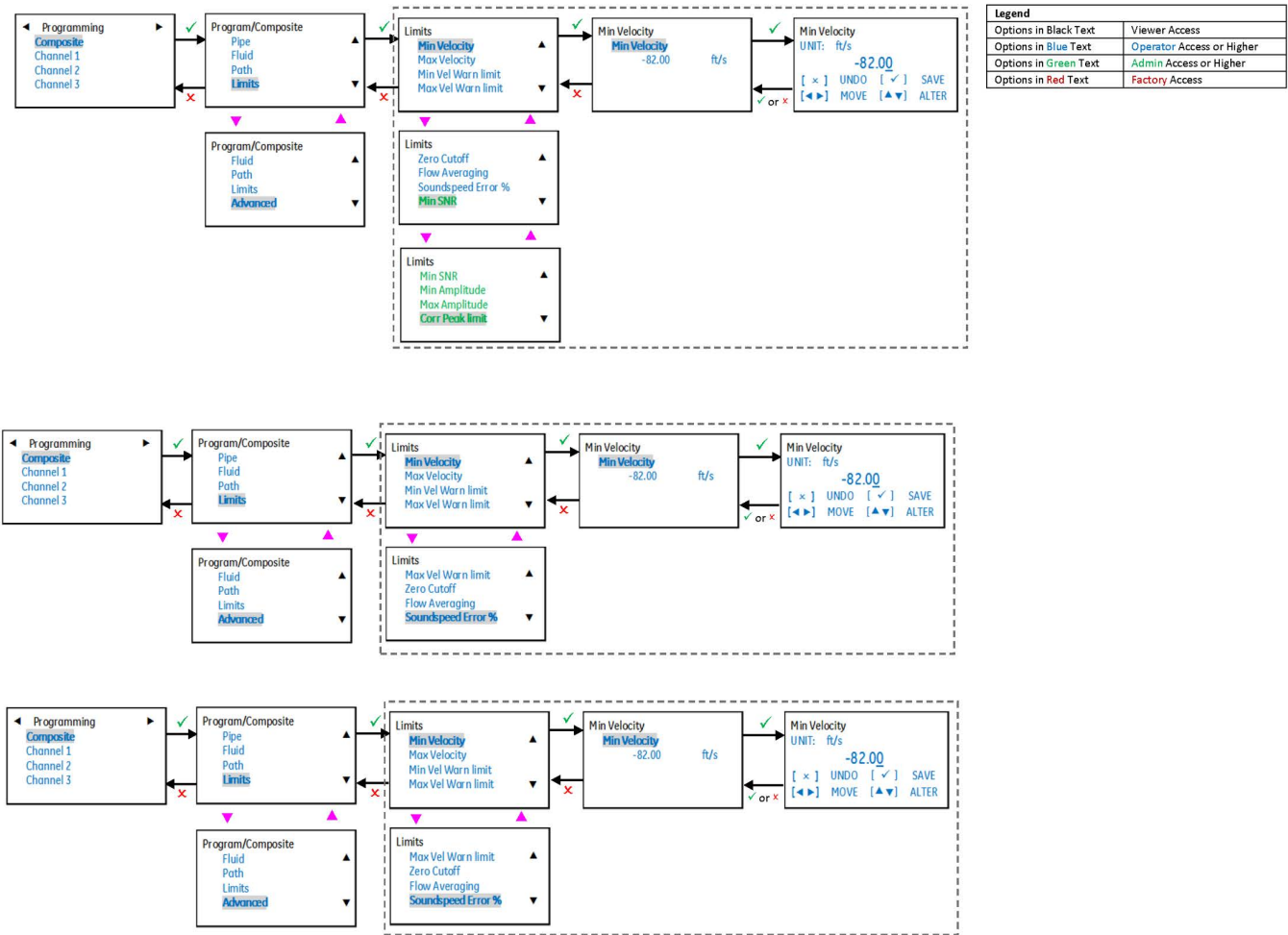

G.13.6 Composite (Advanced Configurations)

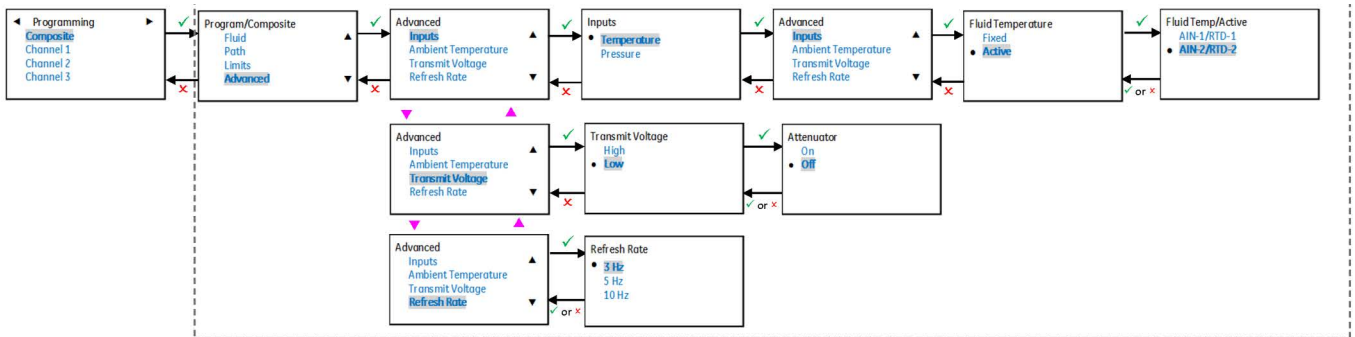
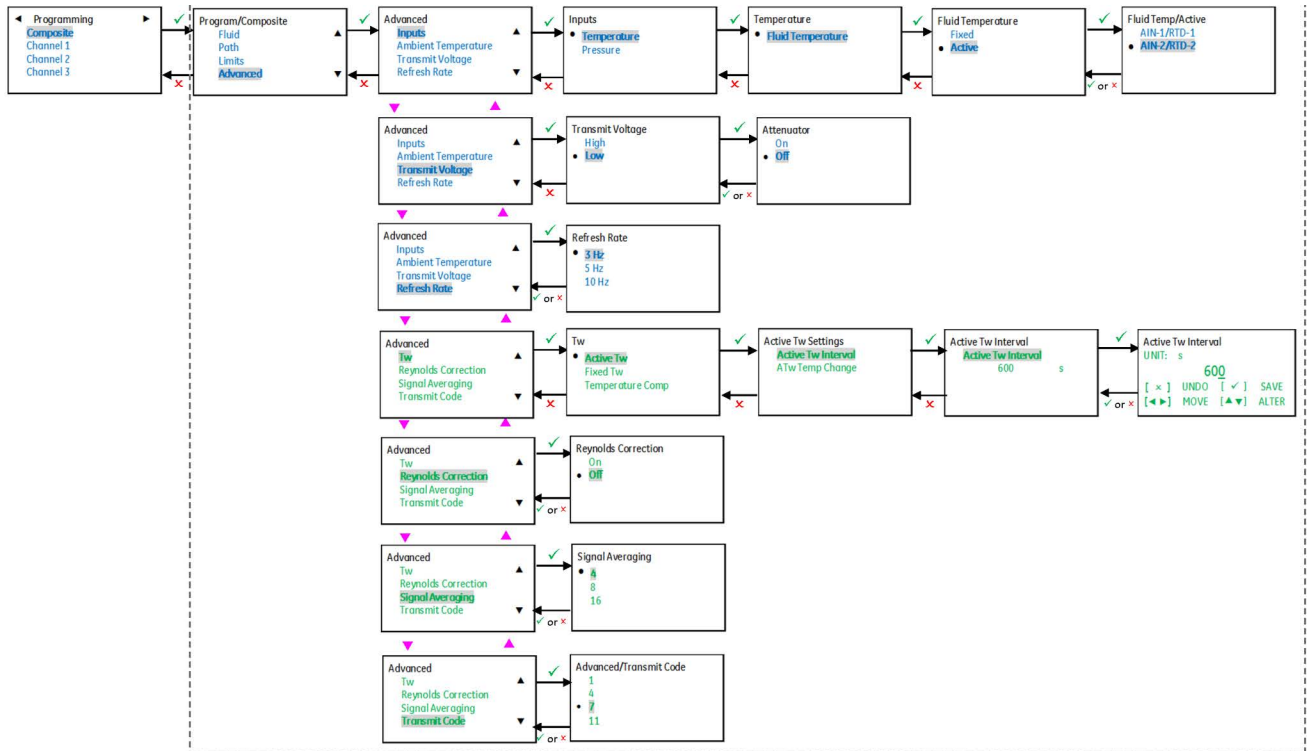

G.13.7 Channels (Clamp-On)

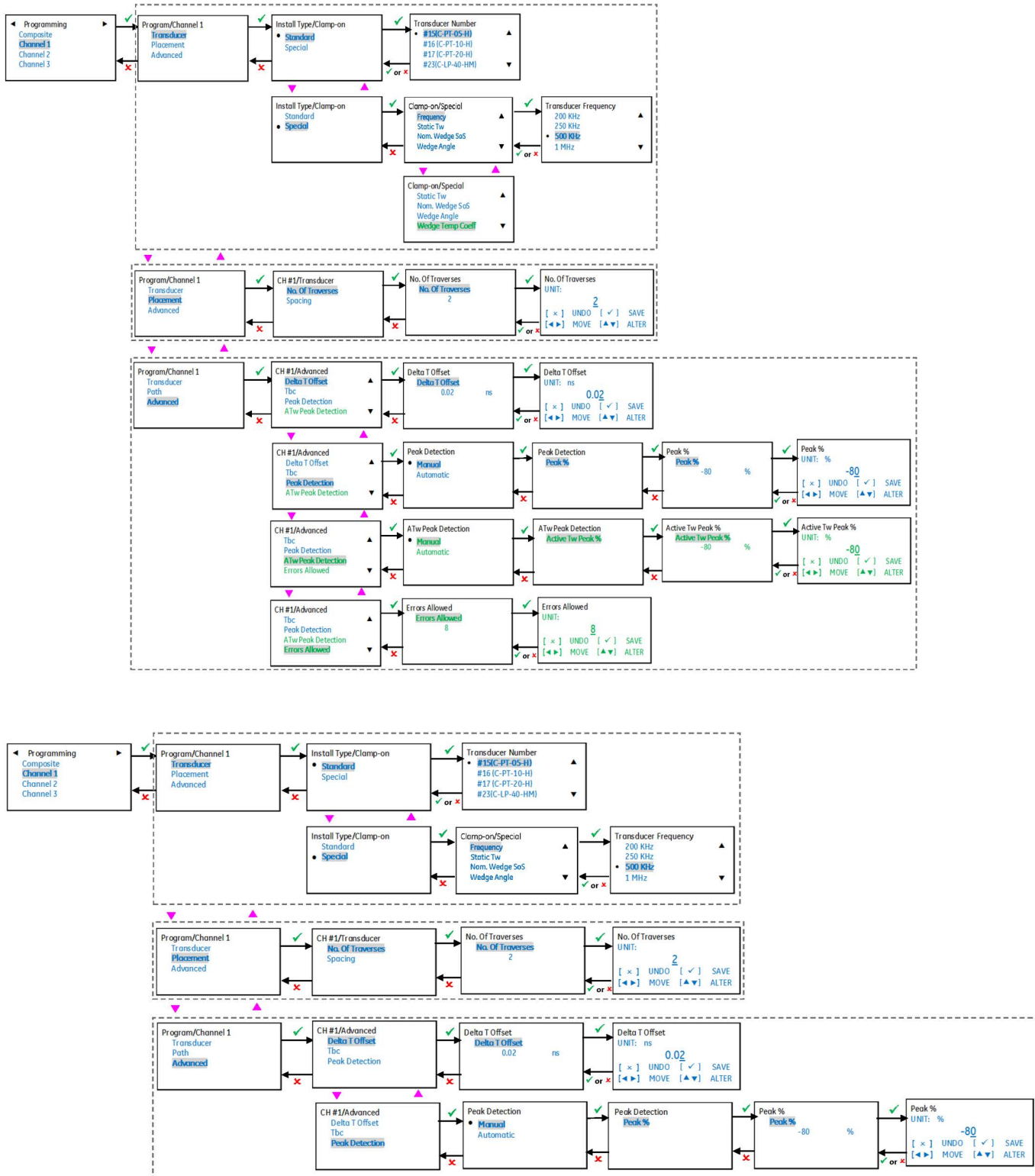

G.13.8 Channels (Wetted)

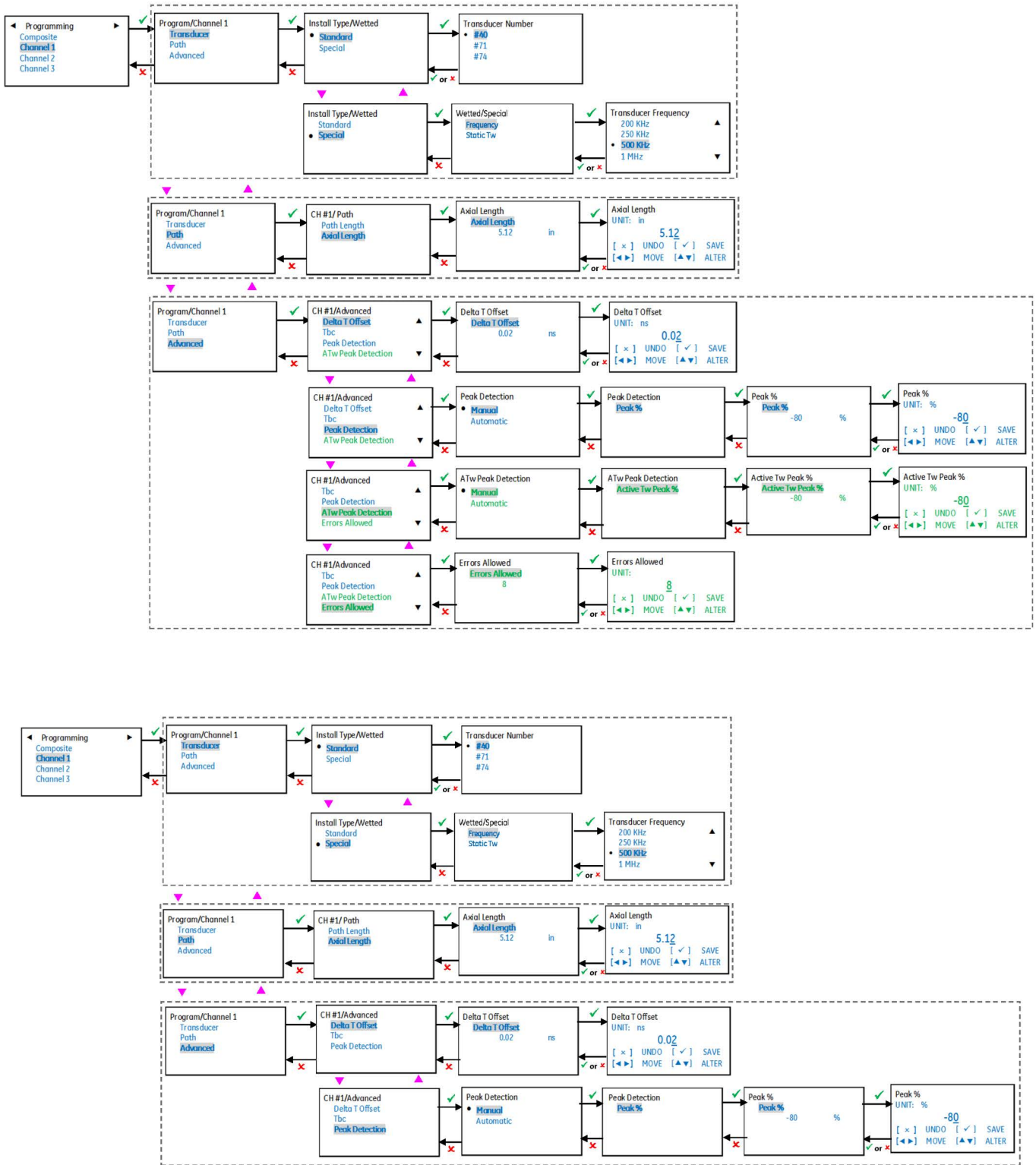

G.14 Calibration

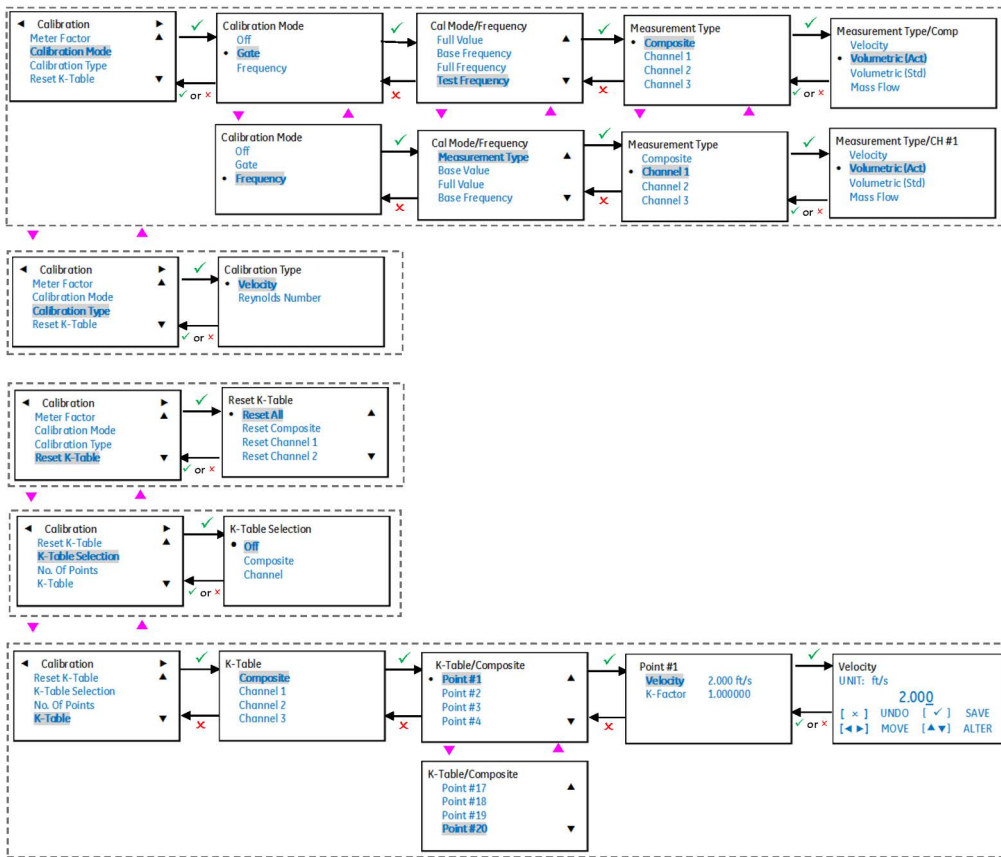

G.15 Advanced

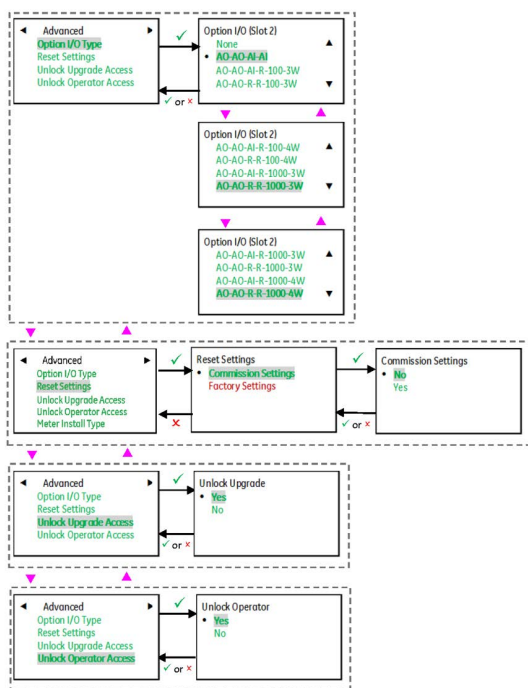

G.16 SIL Testing (Meter Type - SIL)

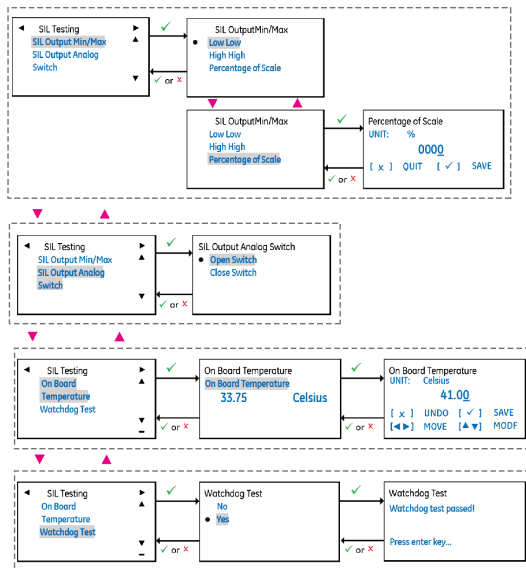

G.17 Factory

G.17.1 Serial Numbers

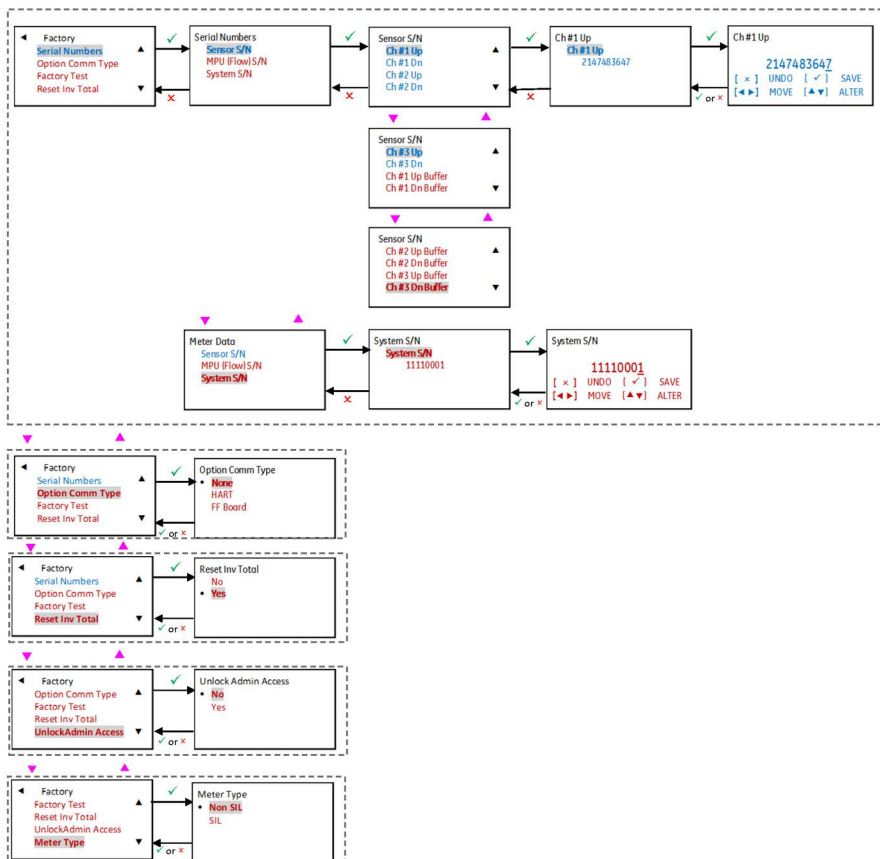

G.17.2 Factory Test

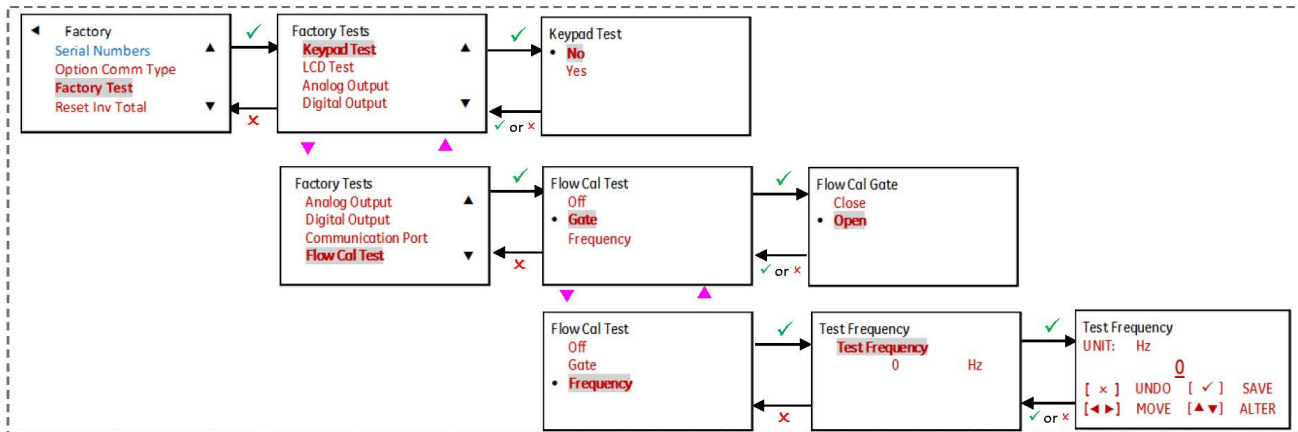

G.18 Input/Output

G.18.1 Option I/O (Slot 2)

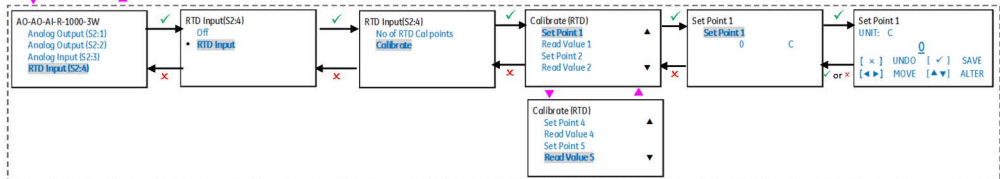
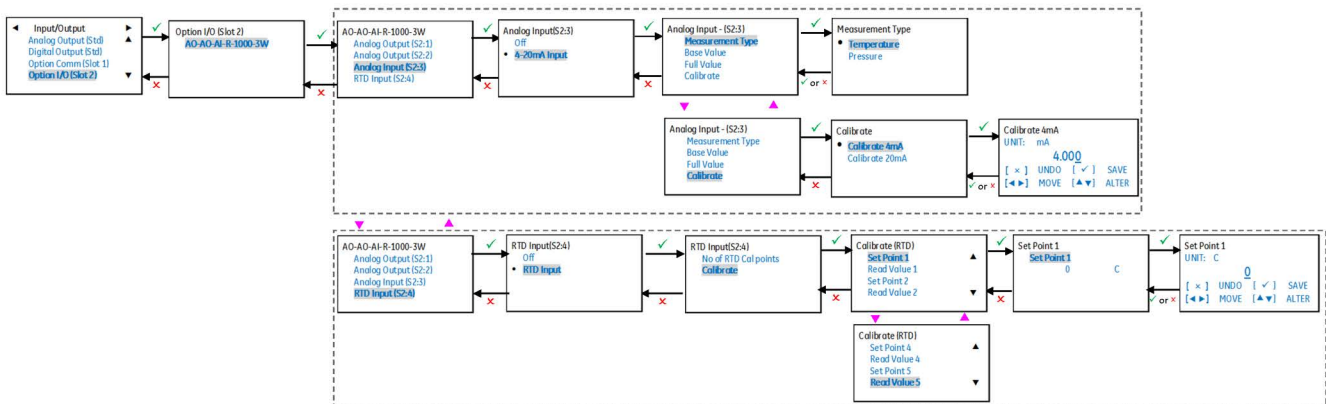

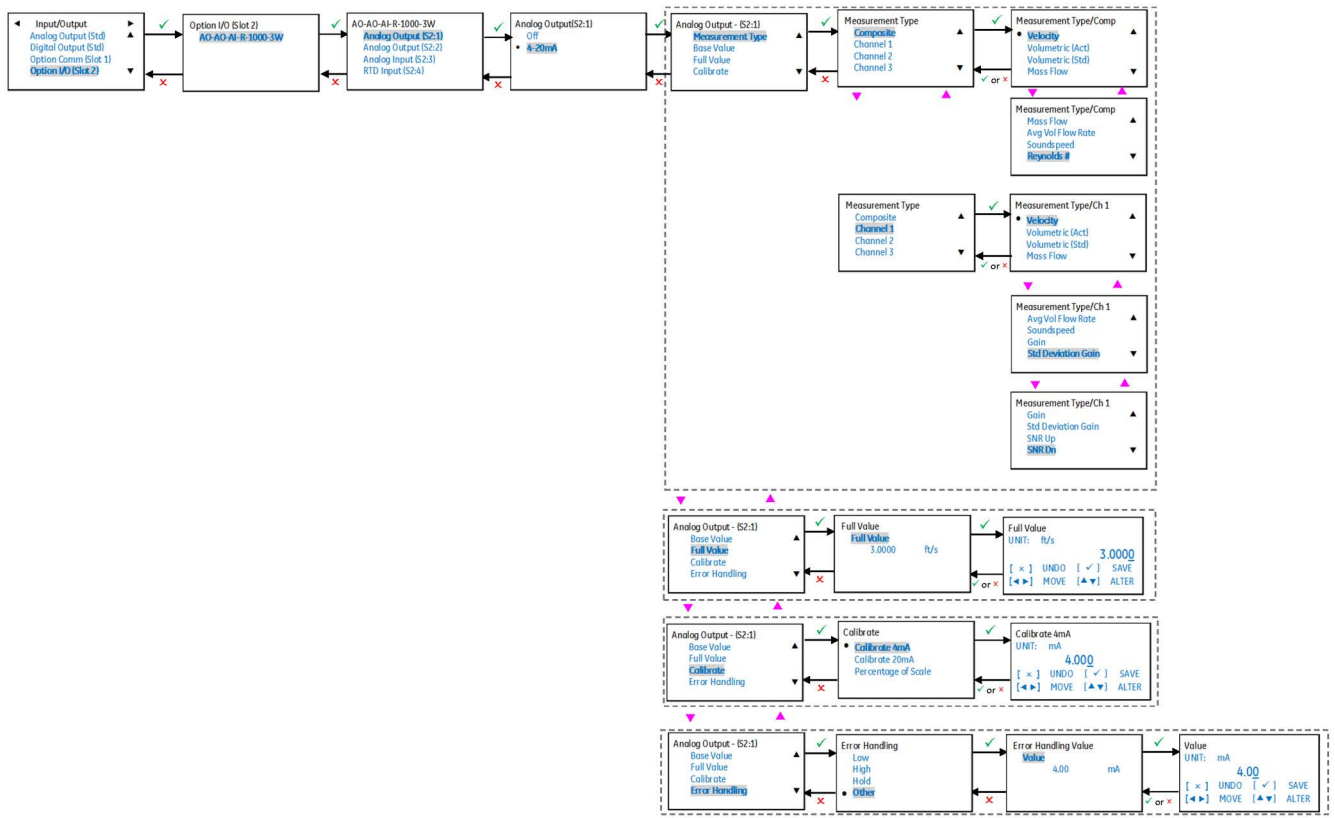

G.18.2 Advanced Output SIL (Meter Type - SIL)

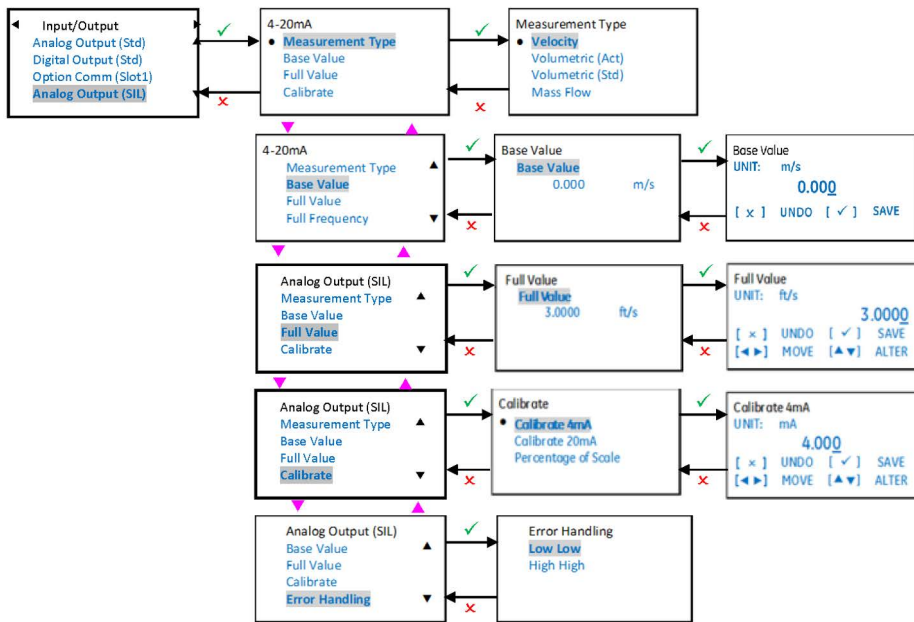

G.19 Display Measurement

G.19.1 One/Two Variable (Composite)

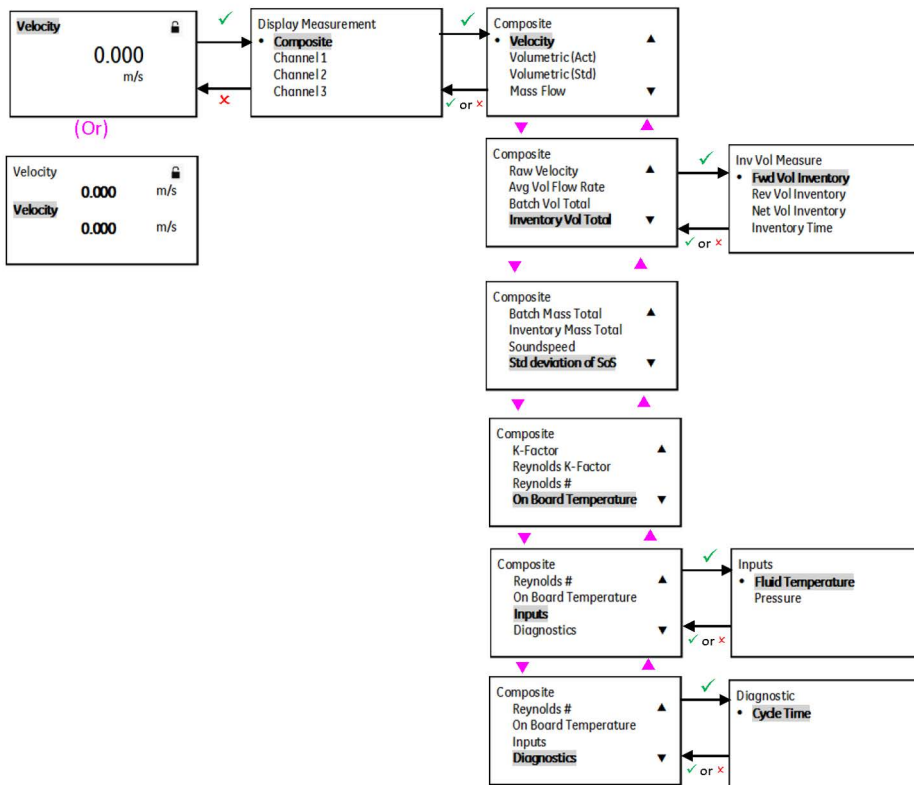

G.19.2 Channel 1

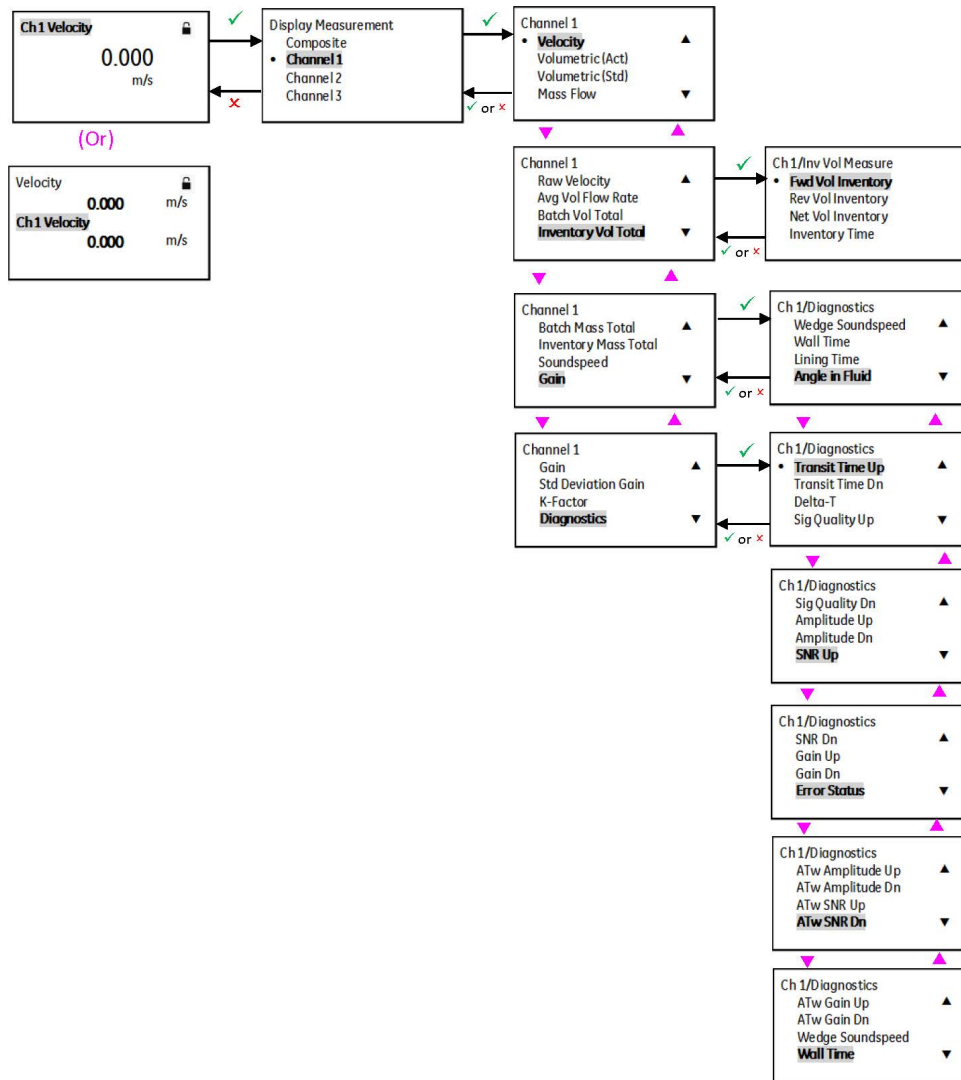

G.20 Measurement View

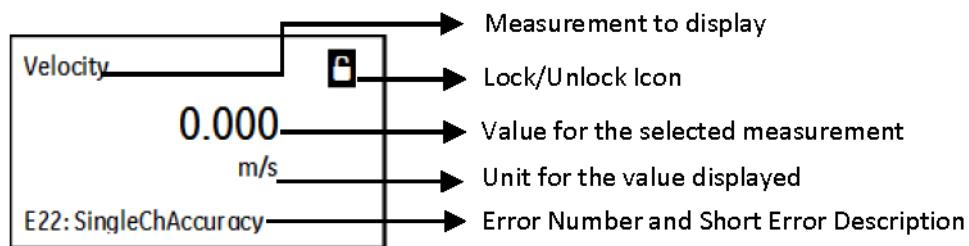

G.21 Forward Volume Total

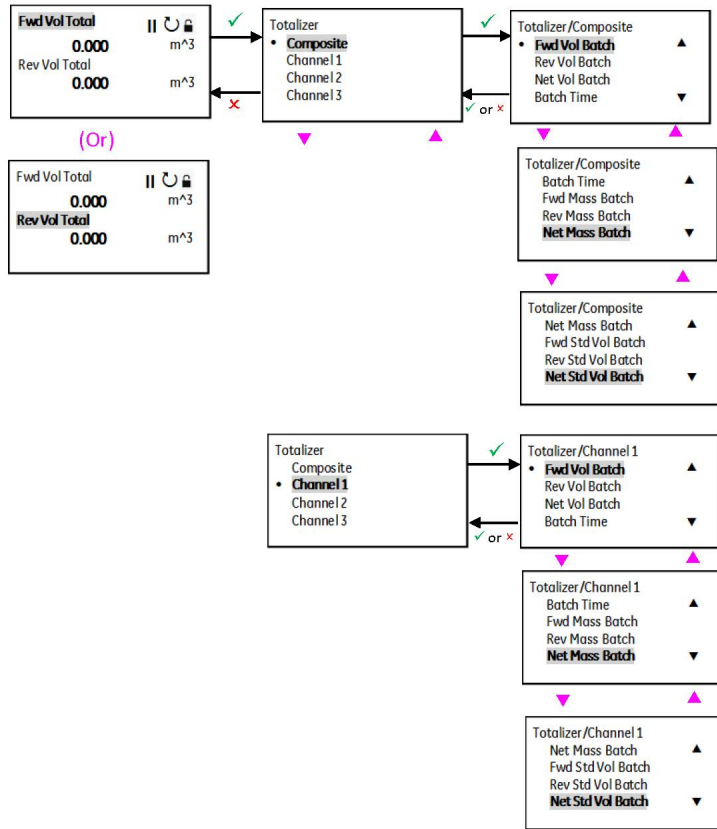

G.22 Totalizer Display

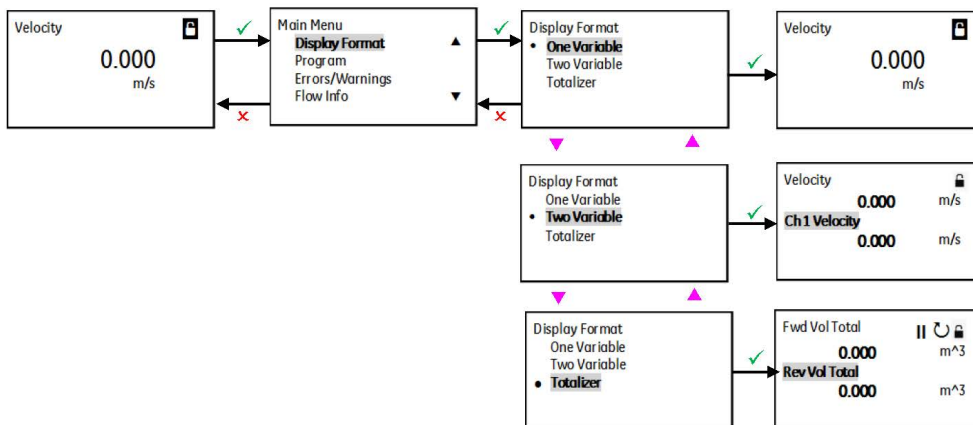

G.23 Process Variable

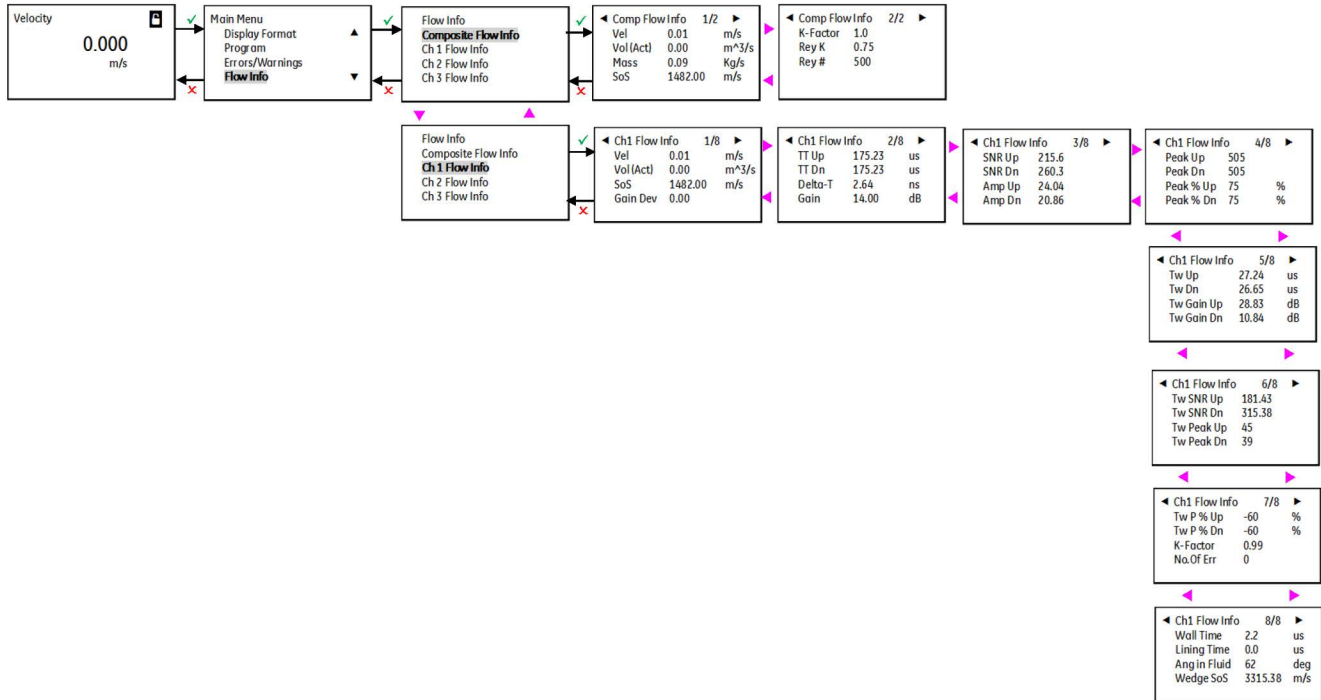

G.24 Main Menu - Error/Warnings

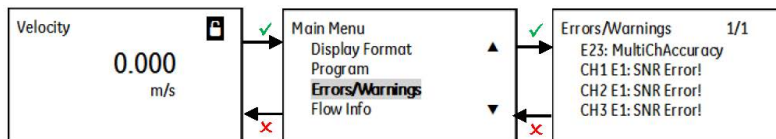

G.25 Main Menu - Software Upgrades

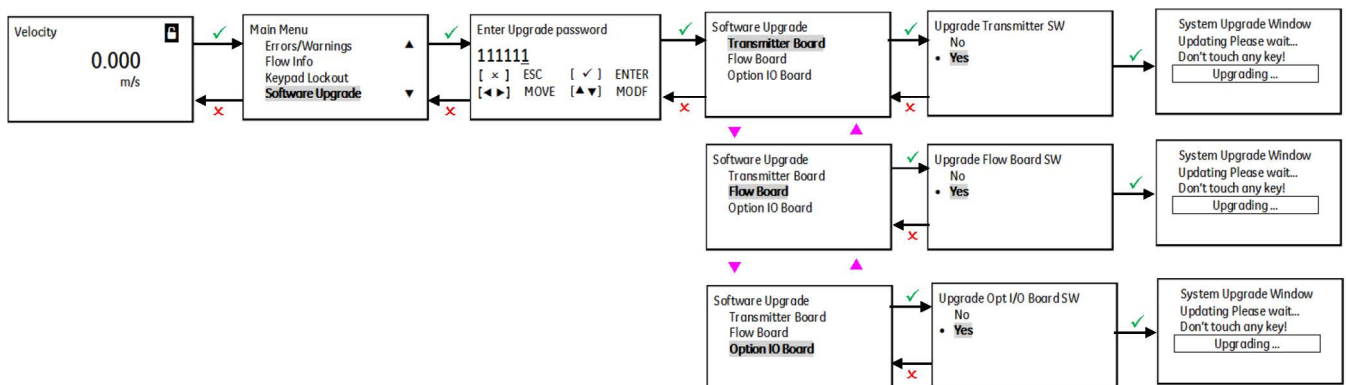

[no content intended for this page]

	A		T
Analog Outputs			Terminal Block
Wiring			Analog Outputs - I/O
Analog Outputs (Slot 0)			Power - TBI
Connecting			Transducer Cables
	C		Transducer Problems
Cable			Transducers
Transducers			Cables
Cable Lengths			Internal Damage
CE Marking Compliance			Location
Connecting			Physical Damage
See Part Name			Problems
	D		Replacement
Data Logging			Typographical Conventions
Digital Outputs			
Wiring			U
	E		Unpacking
Electrical Connections			
	G		V
Grounding			Voltage, Input
	I		
Input Voltage			W
	L		Wiring
Line Power			Analog Outputs
Wiring			CE Marking Compliance
LVD Statement			Digital Outputs
	M		Line Power
Magnetic Keypad, Using			Modbus/Service Port
Modbus			Option Card
Wiring			Terminal Block
	P		Wiring Diagram
PanaFlow HT			
Electrical Connections			
Unpacking			
Wiring Diagram			
PanaFlow Z3			
Magnetic Keypad			
Passcodes			
Problems, Transducers			
	S		
Safety			
Auxiliary Equipment			
General Issues			
Personal Equipment			
Safety Codes			
Services			
Slot 0			
See Analog Outputs (Slot 0)			
Specifications			

[no content intended for this page]

Warranty

Each instrument manufactured by Panametrics is warranted to be free from defects in material and workmanship. Liability under this warranty is limited to restoring the instrument to normal operation or replacing the instrument, at the sole discretion of Panametrics. Fuses and batteries are specifically excluded from any liability. This warranty is effective from the date of delivery to the original purchaser. If Panametrics determines that the equipment was defective, the warranty period is:

- One year from delivery for electronic or mechanical failures.
- One year from delivery for sensor shelf life.

If Panametrics determines that the equipment was damaged by misuse, improper installation, the use of unauthorized replacement parts, or operating conditions outside the guidelines specified by Panametrics, the repairs are not covered under this warranty.

The warranties set forth herein are exclusive and are in lieu of all other warranties whether statutory, express or implied (including warranties or merchantability and fitness for a particular purpose, and warranties arising from course of dealing or usage or trade).

Return Policy

If a Panametrics instrument malfunctions within the warranty period, the following procedure must be completed:

1. Notify Panametrics, giving full details of the problem, and provide the model number and serial number of the instrument. If the nature of the problem indicates the need for factory service, Panametrics will issue a Return Material Authorization (RMA), and shipping instructions for the return of the instrument to a service center will be provided.
2. If Panametrics instructs you to send your instrument to a service center, it must be shipped prepaid to the authorized repair station indicated in the shipping instructions.
3. Upon receipt, Panametrics will evaluate the instrument to determine the cause of the malfunction.

Then, one of the following courses of action will then be taken:

- If the damage is covered under the terms of the warranty, the instrument will be repaired at no cost to the owner and returned.
- If Panametrics determines that the damage is not covered under the terms of the warranty, or if the warranty has expired, an estimate for the cost of the repairs at standard rates will be provided. Upon receipt of the owner's approval to proceed, the instrument will be repaired and returned.

[no content intended for this page]

Customer Support Centers

U.S.A.

The Boston Center
1100 Technology Park Drive
Billerica, MA 01821

U.S.A.

Tel: 800 833 9438 (toll-free)
978 437 1000

E-mail: panametricstechsupport@bakerhughes.com

Ireland

Sensing House
Shannon Free Zone East
Shannon, County Clare
Ireland

Tel: +353 61 61470200

E-mail: panametricstechsupport@bakerhughes.com

**Scan here for Panametrics
support and service information**



Copyright 2024 Baker Hughes company.

This material contains one or more registered trademarks of Baker Hughes Company and its subsidiaries in one or more countries. All third-party product and company names are trademarks of their respective holders.

BH054C11 EN B (04/2024)

Baker Hughes 