

XMTCpro

Thermal Conductivity Binary Gas Analyzer User's Manual



XMTCpro

Thermal Conductivity Binary Gas Analyzer

User's Manual

BH078C11 Rev. A
Dec 2024

panametrics.com

Copyright 2024 Baker Hughes company.

This material contains one or more registered trademarks of Baker Hughes Company and its subsidiaries in one or more countries. All third-party product and company names are trademarks of their respective holders.

[no content intended for this page]

Services



Panametrics provides customers with an experienced staff of customer support personnel ready to respond to technical inquiries, as well as other remote and on-site support needs. To complement our broad portfolio of industry-leading solutions, we offer several types of flexible and scalable support services including: Training, Product Repairs, Service Agreements and more.

Please visit <https://www.bakerhughes.com/panametrics/panametrics-services> for more details.

Typographical Conventions

Note: These paragraphs provide information that provides a deeper understanding of the situation, but is not essential to the proper completion of the instructions.

IMPORTANT: These paragraphs provide information that emphasizes instructions that are essential to proper setup of the equipment. Failure to follow these instructions carefully may cause unreliable performance.



CAUTION! This symbol indicates a risk of potential minor personal injury and/or severe damage to the equipment, unless these instructions are followed carefully.



WARNING! This symbol indicates a risk of potential serious personal injury, unless these instructions are followed carefully.

Safety Issues



WARNING! It is the responsibility of the user to make sure all local, county, state and national codes, regulations, rules and laws related to safety and safe operating conditions are met for each installation.



Attention European Customers! To meet CE Mark requirements for all units intended for use in the EU, all electrical cables must be installed as described in this manual.

Auxiliary Equipment

Local Safety Standards

The user must make sure that he operates all auxiliary equipment in accordance with local codes, standards, regulations, or laws applicable to safety.

Working Area



WARNING! Auxiliary equipment may have both manual and automatic modes of operation. As equipment can move suddenly and without warning, do not enter the work cell of this equipment during automatic operation, and do not enter the work envelope of this equipment during manual operation. If you do, serious injury can result.



WARNING! Make sure that power to the auxiliary equipment is turned OFF and locked out before you perform maintenance procedures on this equipment.

Qualification of Personnel

Make sure that all personnel have manufacturer-approved training applicable to the auxiliary equipment.

Personal Safety Equipment

Make sure that operators and maintenance personnel have all safety equipment applicable to the auxiliary equipment. Examples include safety glasses, protective headgear, safety shoes, etc.

Unauthorized Operation

Make sure that unauthorized personnel cannot gain access to the operation of the equipment.

Environmental Compliance

Waste Electrical and Electronic Equipment (WEEE) Directive

Panametrics is an active participant in Europe's *Waste Electrical and Electronic Equipment (WEEE)* take-back initiative, directive 2012/19/EU.

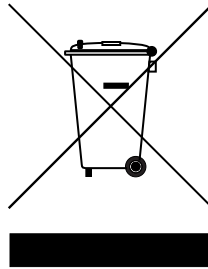

The equipment that you bought has required the extraction and use of natural resources for its production. It may contain hazardous substances that could impact health and the environment.

In order to avoid the dissemination of those substances in our environment and to diminish the pressure on the natural resources, we encourage you to use the appropriate take-back systems. Those systems will reuse or recycle most of the materials of your end of life equipment in a sound way.

The crossed-out wheeled bin symbol invites you to use those systems.

If you need more information on the collection, reuse and recycling systems, please contact your local or regional waste administration.

Please visit www.bakerhughesds.com/health-safety-and-environment-hse for take-back instructions and more information about this initiative.

Chapter 1. Features and capabilities

1.1 Introduction1

1.2 Basic features1

1.3 Product Overview1

1.4 Theory of operation2

1.5 System description.....3

 1.5.1 Packaging and temperature rating.....3

 1.5.2 Sample system4

1.6 Applications.....5

Chapter 2. Installation

2.1 Introduction.....7

2.2 Installing the XMTCpro Analyzer7

2.3 Installing the Sample System7

2.4 Wiring the Analyzer.....9

 2.4.1 Grounding the Enclosure9

 2.4.2 CE Mark Requirements10

 2.4.3 Cable Specifications10

 2.4.3.1 Accessing terminal blocks TB1, TB2, TB3, TB4, and TB1010

 2.4.4 Wiring the Power and Signal Connections.....11

 2.4.5 Wiring the Alarm Relays.....12

2.5 Specific Conditions of Use.....12

Chapter 3. Features and capabilities

3.1 Introduction.....15

3.2 Powering the Analyzer15

3.3 Establishing a Sample Gas Flow15

Chapter 4. Programming with HMI

4.1 The XMTCpro Keypad17

4.2 Dashboard19

4.3 The About Menu19

4.4 Login Menu.....20

 4.4.1 Login as User21

 4.4.2 Login as Admin.....21

 4.4.3 Login as SIL User (SIL ONLY)*21

 4.4.4 Change Password.....22

4.5 Error Handling/Alarms22

 4.5.1 Analog Alarms.....24

 4.5.2 Digital Alarms24

 4.5.3 Trip Points.....24

4.6 Display Config25

 4.6.1 Contrast Settings.....25

 4.6.2 Invert Display.....25

 4.6.3 Units25

4.7 Modbus Parameters26

 4.7.1 Mode.....26

 4.7.2 Port26

 4.7.3 Slave ID.....26

 4.7.4 Baud Rate.....27

 4.7.5 Parity.....27

 4.7.6 Number of Bits27

4.8 Factory Reset28

4.9 Faults and Alarms28

4.10	Proof Tests (SIL Only)	29
4.10.1	Test Solenoids	29
4.10.2	Test Relays	29
4.10.3	Test NAMUR	30
4.10.4	Test Alarms	30
4.10.5	Test 4–20 mA Out1	30
4.10.6	Test 4–20 mA Out2	31

Chapter 5. Programming with Modbus

5.1	Login	33
5.1.1	Login as User	33
5.1.2	Login as Admin	33
5.1.3	Login as SIL User (SIL ONLY)	33
5.2	Change Password	33
5.3	Error Handler/Alarms	34

Chapter 6. Calibration with HMI

6.1	Preparing the XMTcpro for Calibration	35
6.2	Test and Trim	35
6.2.1	Channel Select	36
6.2.2	Trim	36
6.2.3	Test	36
6.2.4	Discard Trim and Save Trim	37
6.3	The Field Cal Menu	37
6.3.1	Configure Cal	37
6.3.1.1	Field Cal Type	38
6.3.1.2	Field Cal percent	38
6.3.1.3	Before Delay Time	38
6.3.1.4	After Delay Time	38
6.3.1.5	Max total drift	39
6.3.2	Perform Cal	39
6.3.3	Calibration Drifts	39
6.3.4	Hold Last Value	40
6.3.5	Abort Cal	40
6.3.6	Clear Cal	40
6.3.7	Save Calibration	40
6.4	Hydrogen Cooled Generator Functions (H2G Only)	41

Chapter 7. Calibration with Modbus

7.1	Test and Trim	43
7.2	Field Calibration	44
7.3	Hydrogen Cooled Generator Functions (H2G Only)	44

Chapter 8. Specifications

8.1	Functional	45
8.2	Performance	45
8.3	Physical	46

Chapter 9. Decommissioning

9.1	Objective	49
9.2	Hazard and Risk Analysis to be Performed by the Customer	49
9.3	Disposal	49

Appendix A. Modbus Map

Appendix B. SIL Modbus Map

Appendix C. Error Codes

Appendix D. Troubleshooting

Appendix E. Menu Maps

E.1 Dashboard & Main Menu 65
 E.2 Measure Menu 65
 E.3 Outputs Menu..... 66
 E.4 Alarms Menu.....67
 E.5 Diagnose Menu 69
 E.6 Config Menu71
 E.7 Cal Menu73
 E.8 About Menu76
 E.9 Login Menu.....76

Appendix F. Bootloader

F.1 Setup.....77
 F.2 Software Setup77
 F.3 Accessing the Bootloader.....78
 F.4 Firmware Upgrade78
 F.5 Bootloader Config Menu.....79
 F.6 Bootloader Test Mode Menu79

Appendix G. CE Mark Compliance

Appendix H. H2G Applications

H.1 Problem83
 H.2 Equipment.....83
 H.3 Basic Operating Procedure83
 H.4 How Previously Handled83
 H.5 Permanent Installation83
 H.6 Specifications.....83
 H.7 Detailed Operating Procedure.....84
 H.7.1 Start Up.....85
 H.7.2 Calibration.....85

Appendix I. Abbreviations

Appendix J. Relative thermal conductivity of common gases

Appendix K. Max Drift Calibration

[no content intended for this page]

Chapter 1. Features and capabilities

1.1 Introduction

This chapter introduces you to the features and capabilities of the Panametrics XMTCpro thermal conductivity based binary gas analyzer. The following topics are discussed:

- Description and basic features of the XMTCpro
- Theory of operation
- Product overview
- System description
- Overview of typical XMTCpro applications

The XMTCpro technical specifications can be found in *Chapter 8*.

1.2 Basic features

The XMTCpro is an analyzer that uses the thermal conductivity of the measured gas to determine its concentration by generating an analog output in the range 4 to 20 mA and a digital output signal proportional to the calibration range of the measured gas. It offers several unique design features:

- Ultra-stable thermistors and a temperature-controlled measuring cell provide excellent zero and span stability, as well as tolerance of ambient temperature variations.
- The measuring cell design makes it highly resistant to contamination and flow vibrations. Since it has no moving parts, the analyzer can handle the shock and vibration found in many industrial applications.
- The modular design of the XMTCpro allows for easy and quick replacement of the sensor and electronics with a replacement module (e.g. a module with different factory calibration) as well as field calibration in just a few minutes.
- The XMTCpro analyzer, with weatherproof and explosion-proof packaging, is designed to be installed as close as possible to the process sample point. It can be located up to 4000 ft (1200 m) from a display or recorder, using unshielded cable.
- An integrated display with user accessible magnetic switch buttons and process/alarm relays.
- 2 x 4-20mA analog outputs.

1.3 Product Overview

As shown in *Figure 1* below, the XMTCpro is equipped with several external features designed to facilitate its operation, maintenance and usability, including:

- Configuration and certification information.
- Mounting holes.
- Cable entries (2 on each side).
- Removable top cover.
- Removable front cover (secured with an adjustment screw).
- Multi-parameter display.
- Magnetic keypad.
- Flame arrestors (gas inlet/outlet) and breather.

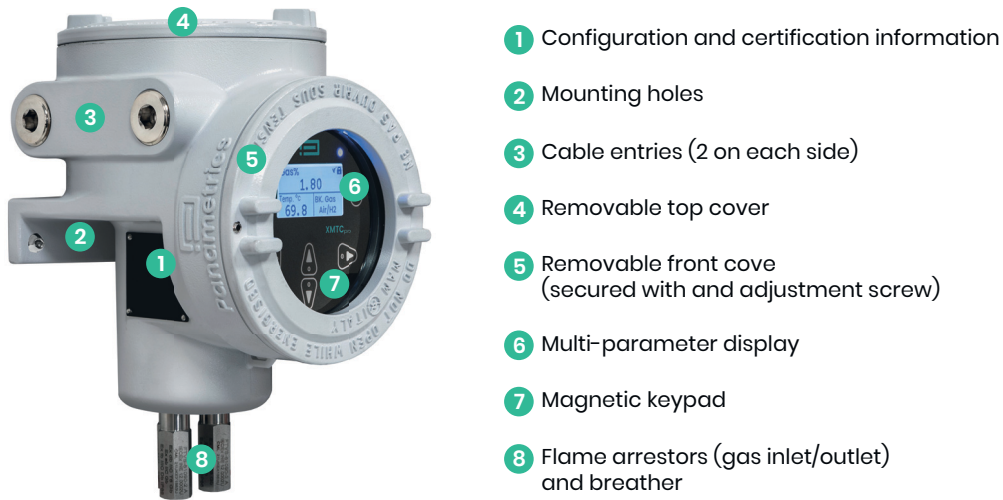

Figure 1: External components of the XMTCpro

1.4 Theory of operation

The XMTCpro measures the concentration of the measurand gas in a binary or pseudo-binary gas mixture, by monitoring the changes in the thermal conductivity of the gas mixture dry air.

Two ultra-stable, glass-coated thermistors are used: one in contact with the sample gas, and the other in contact with dry-air (reference gas) (See Figure 2). The thermistors are mounted so that they are centrally located in a cylindrical metallic cavity, the sample chamber. The entire sensor is heated and the thermistors are heated above the sensor temperature using a constant current source. The measurement chamber is heated slightly above ambient to establish a uniform measurement environment and the thermistors heated to higher temperature again. The power required to maintain the thermistor temperature constant (the rate of heat loss from the thermistors to the chamber walls) is proportional to thermal conductivity of the gases in the chamber (See Figure 3 for the relative thermal conductivity values of some common gases). Thus, each thermistor will reach a different equilibrium temperature. The temperature difference between the two thermistors is detected in an electrical bridge circuit. It is then amplified and converted to a 4–20 mA output or digital output proportional to the concentration of one of the constituents of the binary gas mixture. For example, to calibrate a 0 to 25% H₂ in N₂ unit, the zero gas would be 100% N₂ (i.e. 0% H₂) and the span gas would be 25% H₂ in N₂.

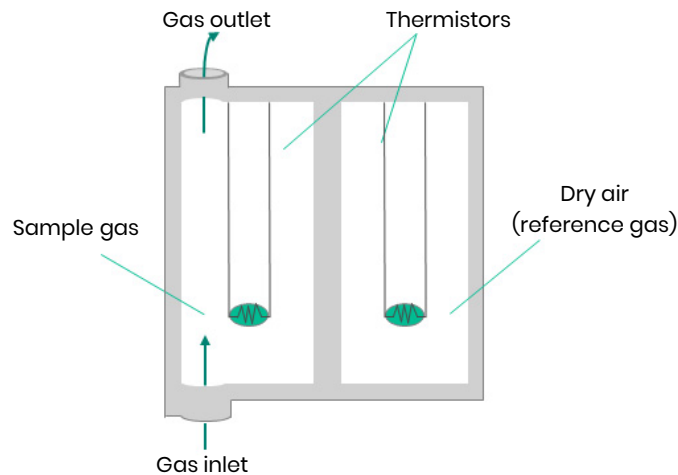

Figure 2: The concentration of a gas in the binary gas mixture is determined by measuring the thermal conductivity of the sample and reference gases using two ultra-stable, glass-coated thermistors.

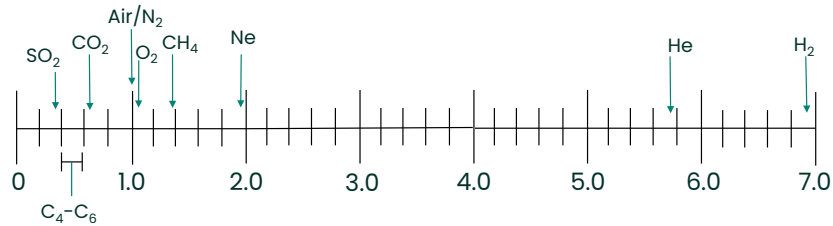

Figure 3: Relative thermal conductivity of some common gases. Appendix J, lists the relative thermal conductivities of common gases.

1.5 System description

As an extractive industrial process gas analyzer, the XMTcpro requires the use of a sample conditioning system. This mandatory sample conditioning system may vary in design (required components) depending on process conditions. Panametrics offers complete solutions based on standard packages, but also designs and manufactures customized sample preparation systems. Please contact Panametrics to find out what is required for a specific application.

The sample system is mandatory and can either be provided by Panametrics or constructed according to Panametrics' recommendations.

1.5.1 Packaging and temperature rating

The XMTcpro analyzer is self-contained, consisting of the thermal conductivity sensor and associated electronics. It requires 24 VDC power (1.5A maximum at power-up), and provides a 4–20 mA output signal proportional to the concentration of one of the gases in the binary sample gas mixture.

The XMTcpro is designed to be installed in a sample system as close as possible to the process sample point. Thus, it is available in two environmental packages:

- Weatherproof
- Explosion-proof (with the addition of flame arrestors for the inlet and outlet)

The XMTcpro is supplied with a standard operating temperature measurement cell. An optional high operating temperature cell is available (See *Ambient Operating Temperature Range in Chapter 8*).

Depending on the requirements of the installation site, the XMTcpro is available with an aluminum or stainless steel enclosure (See *Figure 4*).

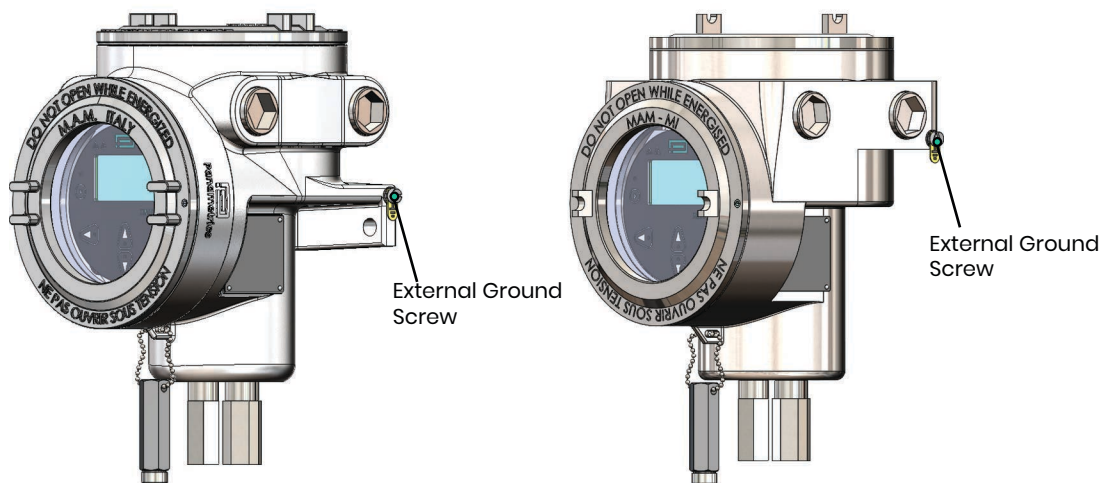

Figure 4: Aluminum (left) and Stainless Steel (right) XMTcpro

As shown in *Figure 5*, the XMTCpro has three ports: a sample gas inlet, outlet and breather port. The breather port serves as a vent for safety, for IEC 60079-1 compliance.

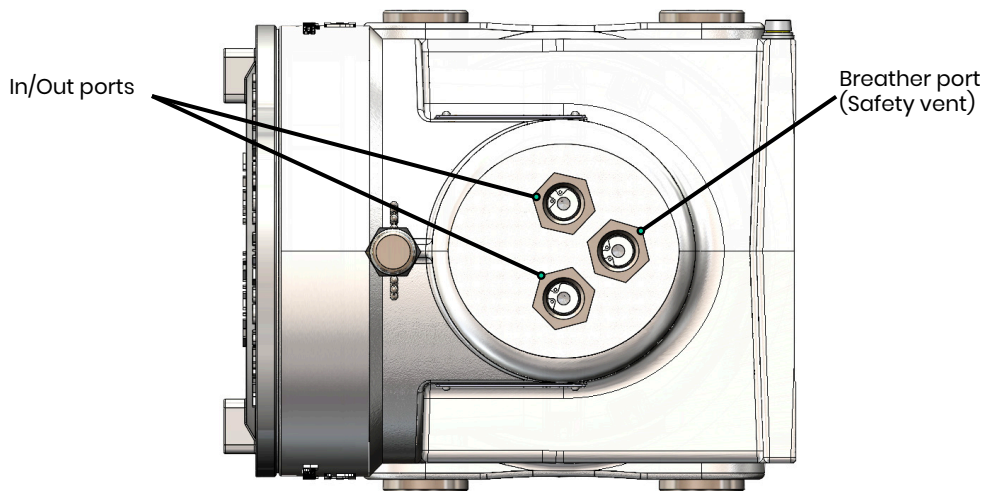

Figure 5: XMTCpro Ports

1.5.2 Sample system

The XMTCpro is an extractive process gas analyzer and requires that the process conditions such as temperature, flow rate, pressure and moisture content are adapted and optimized to the measurement. The components used for this, together with the XMTCpro, form the sample conditioning system.

The design of the sample system depends on the conditions of the sample gas and the requirements of the application. In general, a sample system must deliver a clean, representative sample to the XMTCpro at a temperature, pressure and flow rate that are within acceptable limits. Standard XMTCpro sample conditions are as follows:

- Operating temperature below 50°C (122°F) for the standard operating temperature option (<65°C for the high operating temperature option).
- Atmospheric pressure
- Flow rate 250 cc/min (0.5 SCFH)

Panametrics offers sample systems for a wide variety of applications. A standard sample system for the XMTCpro is shown in *Chapter 2. Installation* on page 7. For assistance in designing your own sample system, please consult the factory.



CAUTION! If the XMTCpro is outside of a Panametrics sample conditioning system, the customer must ensure sample pressure is controlled, e. g. using a pressure regulator, if required in the system design.



CAUTION! If the XMTCpro has not been provided with a Panametrics sample conditioning system, it is recommended that the instrument is mounted to a metallic mounting plate of at least 1.5mm thickness, or a substrate of similar strength.

1.6 Applications

The stable and accurate thermal conductivity sensor, certified globally for use in hazardous area environments, make the XMTCpro the tool of choice for use in:

Hydrogen economy

- H₂ in various applications along the hydrogen value chain.

Metals industry

- H₂ in N₂ atmospheres in metal heat-treating furnaces.

Electric power industry

- H₂ in cooling system for generators.

Petroleum industry

- H₂ in hydrocarbon streams.

Chemical industry

- H₂ in NH₃ and in CH₃OH synthesis gas.
- H₂ in chlorine plants.

Methane industry

- CO₂ in CH₄.

Landfill/biogas industry

- CO₂ in biogas.
- CH₄ in biogas.

Gas production industry

- Purity monitoring of Ar, H₂, N₂, and He.

Food industry

- CO₂ in fermentation process.

[no content intended for this page]

Chapter 2. Installation

2.1 Introduction

This chapter describes how to install the XMTCpro analyzer and its sample system. It also contains information on connecting the XMTCpro to optional system components. The following topics are discussed:

- Mounting the XMTCpro analyzer
- Installing a Panametrics sample system
- Wiring the XMTCpro analyzer



WARNING! It is the responsibility of the end user to ensure that any site personnel who are performing installation, commissioning and maintenance have been trained in proper site procedures for working with and around Baker Hughes supplied equipment, per Safe Work Practices.



WARNING! Proper Lockout/Tagout of energy sources prior to maintenance, per Safe Site Work Practices, is the end user's responsibility.

2.2 Installing the XMTCpro Analyzer

This section applies only if you are mounting the XMTCpro analyzer in a sample system that has not been supplied by Panametrics.

Your sample system should deliver a clean, representative sample to the XMTCpro at the proper temperature, pressure and flow rate. This usually means a clean, dry sample (free of solid and liquid particulates) at atmospheric pressure; a temperature no greater than 50°C (122°F) or 65°C (149°F) for the optional high temperature cell; and a flow rate of approximately 250 cc/min (0.5 SCFH). Since factory calibration of the sensor is at atmospheric pressure and 250 cc/min (0.5 SCFH), higher or lower operating pressure may necessitate field-calibration adjustment.

A simple sample system for the XMTCpro might have inlet and outlet flow-regulating needle valves, a flow meter, and a pressure gauge, in addition to the XMTCpro analyzer.

The XMTCpro analyzer should be mounted in the sample system so that it is upright and level to within $\pm 15^\circ$. Also, provide at least 230 mm (9 in.) of clearance above the top cover of the analyzer to allow access to the analyzer printed circuit board (PCB) for connecting the cables before commissioning or maintenance. Connect the sample inlet and sample outlet ports to the appropriate XMTCpro port.

Note: Ensure all covers and cable glands (or conduit if applicable) are threaded and sealed correctly to maintain IP66 and NEMA 4X protection ratings.



WARNING! Customer to ensure correct safety practices and any applicable regional regulations are followed when handling pressurized gas and when connecting same to the XMTCpro instrument and/or any equipment provided by Panametrics.

2.3 Installing the Sample System

You can order a complete sample system from the factory. This includes the XMTCpro analyzer and all necessary components and sample tubing mounted on a metal panel. Several standard sample conditioning systems are available. Panametrics can design and build custom sample systems according to your exact specifications.

Mount the sample system as close to the process sample point as possible. Once the sample system is mounted, connect all inlet and outlet lines via the 1/4" (or regional equivalent) compression fittings on the sample system. The sample line leading from the process to the sample system should be of 1/4" stainless steel tubing, and should be as short as possible in order to ensure a faster response time.

Figure 6 shows an example of a basic sample conditioning system with the XMTcpro. This sample system consists of inlet needle valves for sample, zero, and span gases; 3-way ball valves; an XMTcpro; a pressure gauge and a sample flowmeter. All components are mounted on a painted steel or stainless steel plate. Depending on the process conditions, other components may also be required such as: filter/coalescer (added for filtration), regulator (pressure control), and pump (flow control).

When the XMTcpro is purchased without a sample conditioning system provided by Panametrics, the customer must ensure that the process gas when connected to the XMTcpro is regulated to a pressure of as close to atmospheric pressure as is possible, but no higher than 2 bar(g) / 0.2 MPa(g) so as not to violate compliance with the requirements of the certification per Annex G of EN/IEC 60079-1. Similarly, the process flow must be regulated to a flowrate of 0.24L/min (0.5 SCFH) ideally but not higher than 1.25L/min (2.65 SCFH) in order to comply with the certification requirements of Annex G of EN/IEC 60079-1. The process gas stream should be free of particulate to prevent damage to the sensor.

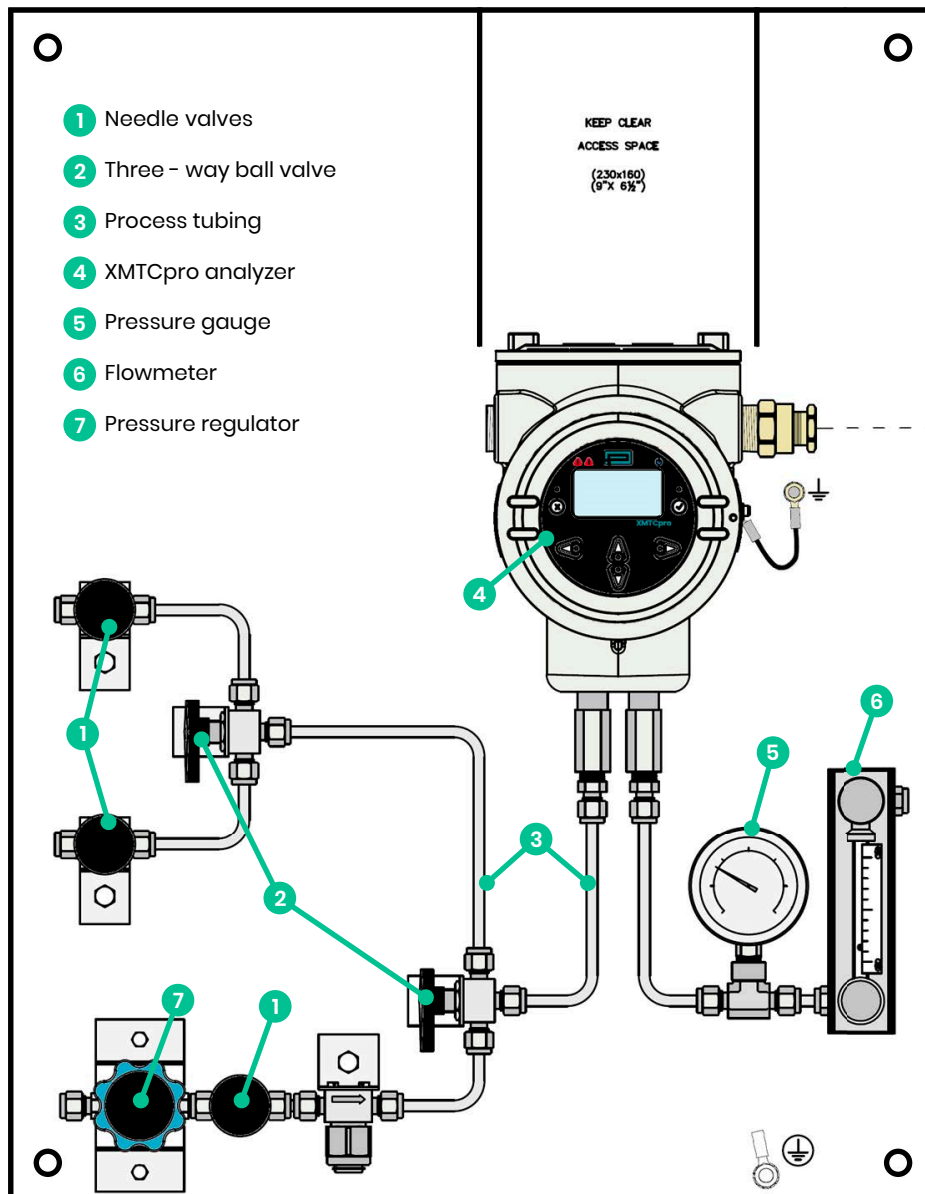

Figure 6: Basic Sample System for XMTcpro

2.4 Wiring the Analyzer

This section describes how to make all necessary electrical connections to the XMTcpro sample system.



Do not apply power during installation.

IMPORTANT: Installation shall be in accordance with the installation instructions and the National Electrical Code® ANSI/NFPA 70, the Canadian Electrical Code C22.1, or IEC/EN 60079-14, as applicable.

IMPORTANT: For weatherproof applications, ensure that cable entry devices are certified at minimum to IP66 and/or Type 4X as applicable.

2.4.1 Grounding the Enclosure



WARNING! The XMTcpro analyzer enclosure must be properly grounded. Connect the external ground screw on the XMTcpro enclosure (see Figure 7 below) to a suitable earth ground.

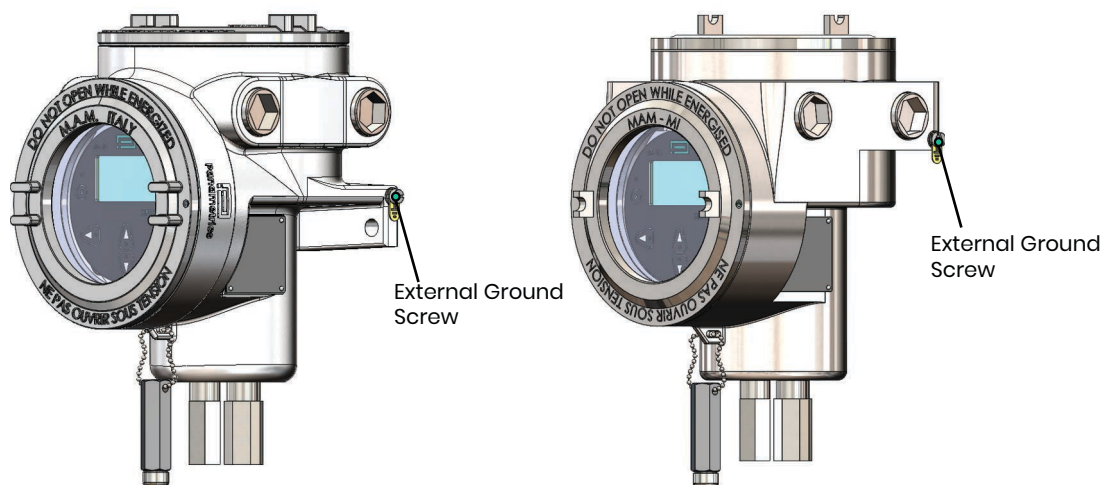

Figure 7: External ground screw locations for Aluminum and Stainless Steel versions of XMTcpro

2.4.2 CE Mark Requirements



WARNING! To meet CE Mark requirements, you must shield and ground all electrical cables as described in *Appendix G. CE Mark Compliance on page 81*.



WARNING! CE Mark compliance is required for all units installed in EU countries.



WARNING! Cable entry devices of an approved flameproof design are required. These must be installed according to the manufacturer's instructions the choice of cable entry device may limit the overall installation category achieved.

2.4.3 Cable Specifications

PSU cable: 2-core, shielded, twisted pair cable [TB1]{Port A}

4-20mA Outputs cable: 4-core, shielded, twisted pairs cable [TB4]{Port B}

Digital comms cable: 3-core, shielded, RS-232/RS-485 cable [TB10]{Port C}

Relay cables: 12-core, shielded cable [TB2 & TB3] {Port D}

Refer to *Figure 8* for port location and *Table 1* for PSU cable length requirements:

Table 1: Cable length requirements

Maximum cable Length		Wire Size	
ft	m	AWG	mm ²
450	137	22	0.3
700	213	20	0.50
1050	320	18	0.8
1700	518	16	1.3
2800	853	14	2.00
4000	1219	12	3.3

2.4.3.1 Accessing terminal blocks TB1, TB2, TB3, TB4, and TB10

The 24 VDC power input, 4-20 mA analog outputs, relay outputs and digital comms outputs wiring connections are made to terminal blocks TB1, TB2, TB3, TB4, and TB10 inside the XMTCpro enclosure (see *Figure 8*). To access this terminal block, loosen the locking screw and remove the cover from the analyzer. Then, refer to *Figure 8* for the location and pin designations of terminal blocks TB1, TB2, TB3, TB4, and TB10.



CAUTION! Do not make any connections to any unused pins on terminal blocks TB1, TB2, TB3, TB4, TB10, and TB11.

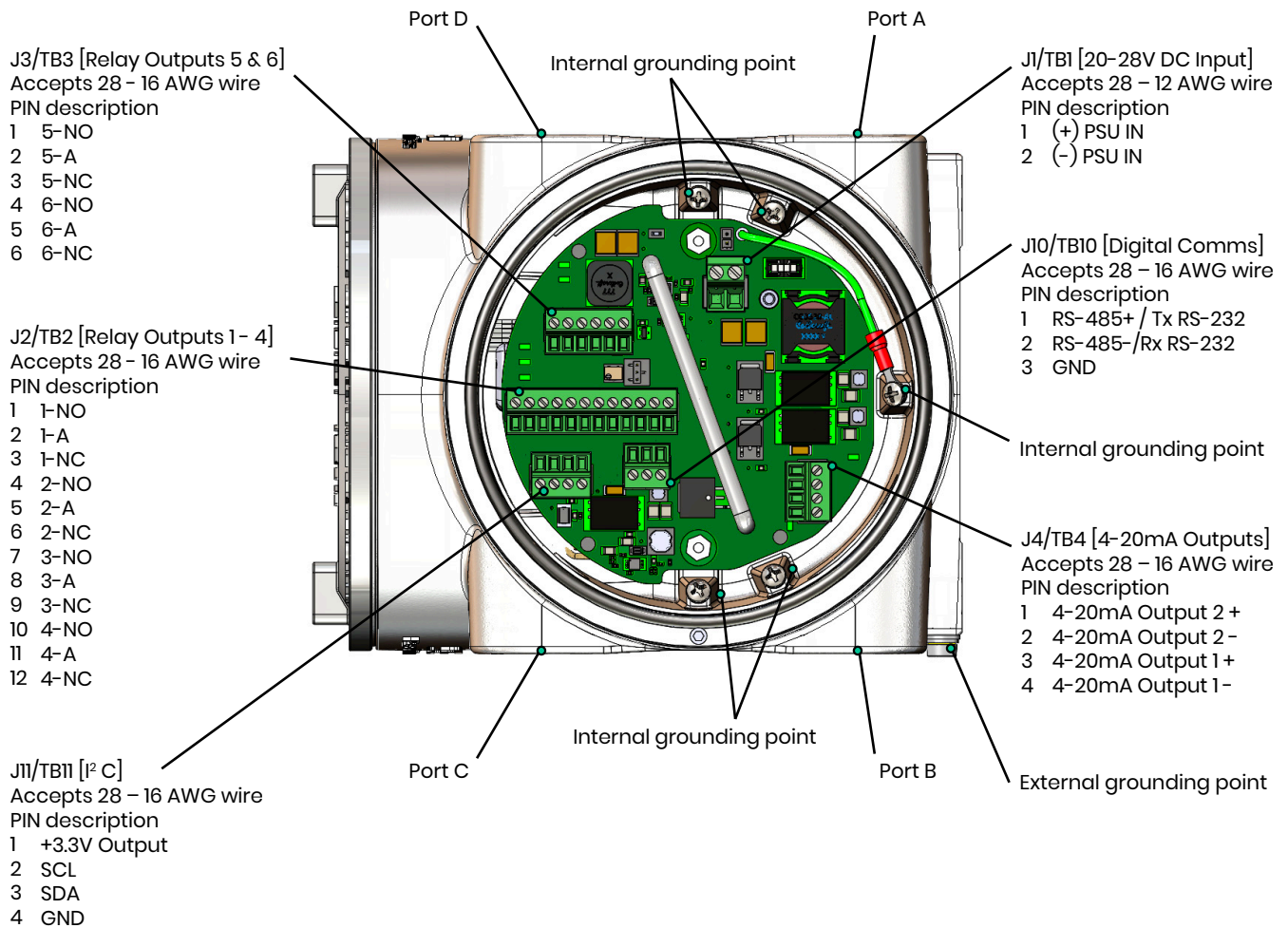

Figure 8: Wiring Diagram

2.4.4 Wiring the Power and Signal Connections

Complete the following steps to make the signal connections to the analyzer:

1. Install a cable clamp or gland in the 3/4" conduit hole.



CAUTION! Unused cable entries on the enclosure should be sealed to maintain the specified weatherproof or explosion-proof rating.

2. Route the associated cable through the cable clamp as described in *Section 2.4.3 Cable Specifications*. Then, tighten the clamp to secure the cable.
3. Unplug the associated connector to this cable as outlined in *Section 2.4.3 Cable Specifications* by pulling them straight off the printed circuit board and loosen the screws on the side of the connectors.

4. Connect the appropriate leads per the wiring diagram in *Figure 8*.



CAUTION! Connecting the +24 VDC lead to any terminal except TBI-1 will damage the XMTCpro.

Complete the following steps to safely finalize the wiring of the device.

1. Carefully plug the TBI, TB2, TB3, TB10 connectors back onto the printed circuit board, and reinstall the cover on the XMTCpro.
2. Connect the other ends of the cables to the 24 ± 4 VDC power supply, the 4-20 mA inputs of the display/control device, and the serial port of the computer or terminal (see the instruction manuals for those devices for details).

2.4.5 Wiring the Alarm Relays

Terminal block J3 contains connections for the Alarm Relays. To wire these alarms, complete the steps described below.

Note: A failsafe alarm is wired to the normally-closed (NC) contacts, while a non-failsafe alarm is wired to the normally-open (NO) contacts. Alarms LL, L and H are factory-configured as non-failsafe. Alarm HH is factory-configured as failsafe. Alternative configuration by the user is not possible.

1. **LL Alarm** (factory-configured as non-failsafe):
 - a. Connect pin #1 (NO) to the alarm device input.
 - b. Connect pin #2 (A) to the alarm device return.
2. **L Alarm** (factory-configured as non-failsafe):
 - a. Connect pin #4 (NO) to the alarm device input.
 - b. Connect pin #5 (A) to the alarm device return.
3. **H Alarm** (factory-configured as non-failsafe):
 - a. Connect pin #7 (NO) to the alarm device input.
 - b. Connect pin #8 (A) to the alarm device return.
4. **HH Alarm** (System Fault Alarm) (**this alarm is factory-configured in failsafe mode**)
 - a. Connect pin #11 (A) to the alarm device return.
 - b. Connect Pin #12 (NC) to the alarm device input.

2.5 Specific Conditions of Use

The XMTCpro has hazardous area certifications for multiple regions. Special conditions are required for safe operation. These are as follows:

1. Do not open when an explosive environment is present.
2. Do not block or restrict the enclosure vent (3rd flame arrestor).
3. The maximum inlet pressure is 2 bar(g)/0.2 MPa(g).
4. The maximum inlet flow rate is 1.25L/min (2.65 SCFH). An up-stream flow limiting device is required.
5. To avoid the risk of electrostatic-charging of the painted surface, the apparatus should only be cleaned with a damp cloth. Guidance on protection against the risk of ignition due to electrostatic discharge can be found in documents such as IEC TS 60079-32-1, ANSI/UL 60079-32 & C22.2 No. 60079-32.
6. The internal CR1632 battery should not need to be replaced during the lifetime of the XMTCpro. Should replacement be necessary, this shall only be performed by authorized service personnel. Only RENATA or Panasonic batteries are permitted for devices installed in hazardous areas.

- 7.** The apparatus cannot be repaired by the user. Specifically, the flameproof design was assessed with non-standard thread lengths and cemented joints; these cannot be repaired. Contact Panametrics service team for assistance.
- 8.** Connecting cables shall be mounted securely and protected from mechanical damage, pulling and twisting.
- 9.** Cable entry devices of a suitably certified flameproof design are required. These must be installed according to the manufacturer's instructions.
- 10.** Unused entries must be sealed using a suitably certified threaded plug.
- 11.** All threaded entries shall be wrench-tight, suggested minimum torque is 54 N.m / 40 lbf-ft.
- 12.** For Class I and Zone 1 installations under (US) NEC or (Canadian) CEC jurisdiction, seal all conduit entries within 18" of the enclosure.
- 13.** Modifications to the flameproof enclosure are not permitted.
- 14.** Only trained, competent personnel may install, operate, and maintain the equipment.
- 15.** The product is an electrical apparatus and must be installed in the hazardous area in accordance with the requirements of the issued certificate. The installation must be carried out in accordance with all the appropriate international, national and local standard codes and practices and site regulations for flameproof apparatus and in accordance with the instructions contained in the manual. Access to the circuitry must not be made during operation.

[no content intended for this page]

Chapter 3. Features and capabilities

3.1 Introduction

This chapter provides information on operating the XMTCpro analyzer. The following topics are discussed:

- Powering up the XMTCpro
- Basic sample gas considerations

If you have not already done so, please read *Chapter 2, Installation on page 7*, for details on mounting and wiring the XMTCpro and the sample system.

3.2 Powering the Analyzer

The XMTCpro analyzer does not have a power switch. It begins taking measurements and generating an analog output signal in the 4-20 mA range as soon as it is connected to a 24 VDC power source. To power the system, simply apply 24 ± 4 VDC power.

The XMTCpro measurement cell is controlled at a constant, elevated, operating temperature. Allow at least 60 minutes for the unit to warm up and reach temperature stability for accurate measurements. During this time, you can establish a sample gas flow through the system, as described in the next section.



CAUTION! It is the responsibility of the user to ensure that all cable entry devices and covers are properly installed and secure prior to applying power to the XMTCpro.

3.3 Establishing a Sample Gas Flow

Open the necessary valves to establish a sample gas flow of 250 cc/min (0.5 SCFH) at atmospheric pressure. Make sure that nothing obstructs the flow of sample gas, thereby causing a pressure buildup in the sensing chamber. For proper operation, the XMTCpro should be vented to atmosphere.

Note: Unless otherwise specified, the XMTCpro is factory calibrated at atmospheric pressure and 250 cc/min (0.5 SCFH) and should therefore be operated at atmospheric pressure. Operating the XMTCpro at any other pressure will necessitate a field calibration at that pressure in order to maintain accuracy. See Chapter 4, *Programming with HMI on page 17*, for more information.



WARNING! Users to exercise extreme caution when mixing gases which can create explosive/hazardous environment.

[no content intended for this page]

Chapter 4. Programming with HMI

The XMTcpro is factory-programmed and ready for use. You may access its programming using the HMI or a Modbus Client Software through your PC.

4.1 The XMTcpro Keypad

Along with the 128 x 64, monochrome LCD, the XMTcpro analyzer includes a 6-key magnetic keypad (See *Figure 9*). The decal cutout for each key contains a hall effect sensor, pushbutton switch and visible red LED. The magnetic wand used to activate a magnetic key is found attached to the meter chassis below the front panel. An operator activates the key by pressing the magnetic wand up to the glass lid over the desired key. The LED will light indicating a successful key press.

Note: *The pushbutton switch will also act as a key press but is done with the glass lid open. Do not use the pushbutton switch in a hazardous area where the lid needs to be installed.*

Use the magnetic keypad to navigate through the user program. The menu map may be followed in sequence, or the four arrow keys may be used to scroll through the prompt screens.

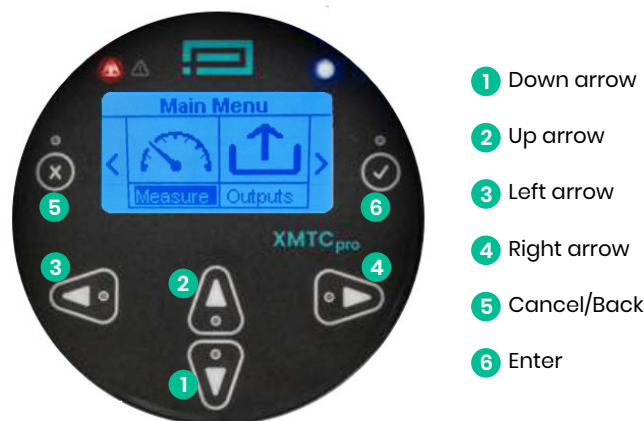

Figure 9: Keypad layout

IMPORTANT: The XMTcpro keypad enables programming of the instrument through the glass faceplate without removing the cover. Thus, all programming procedures may be performed while the unit is installed in a hazardous area.

Six keys on the keypad enable users to program the XMTcpro:

- [✓] - Enter: confirms choice of a specific option and data entry within the option.
- [✗] - Cancel/Back: allows users to cancel a selection and/or return to the previous option.
- [▲] [▼] - up and down: enable users to navigate through the sub-menu after entering one of the main menu options (using the Enter key).
- [◀] [▶] - left and right: enable users to scroll to a specific option, among choices in an option, or to a character in a text entry.

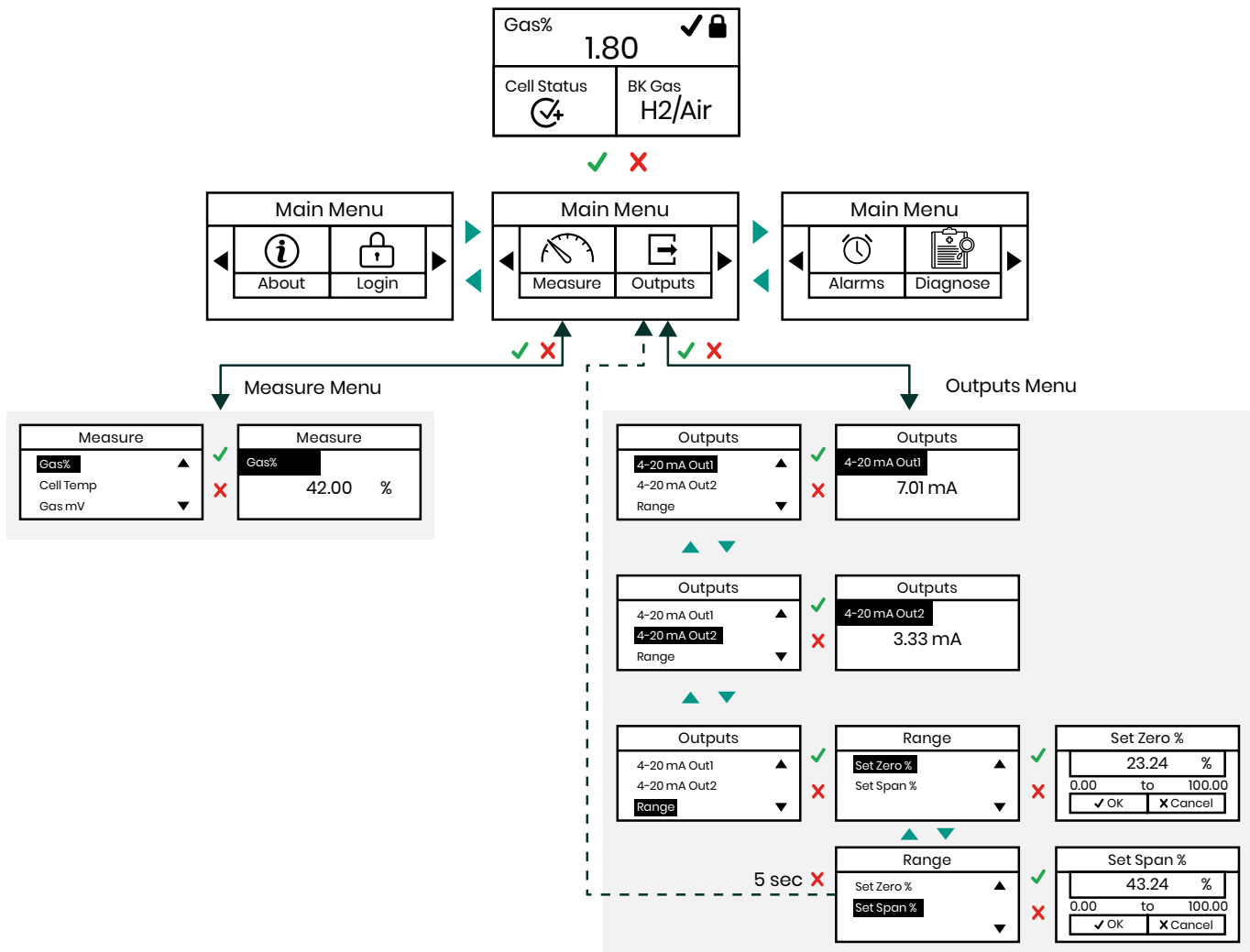

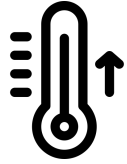
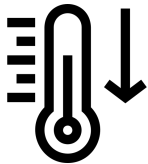

Figure 10: Snapshot of the XMTcpro User Menu

For a complete overview of the navigation options available for programming the XMTcpro, please refer to the full menu map located in *Appendix E, page 65*.

4.2 Dashboard

The XMTcpro dashboard screen provides real time monitoring of key parameters related to the analyzer performance.

1. Gas %: This shows the percentage of the signal gas in the gas mixture. It provides a direct measurement of the signal gas concentration.
2. Cell Temp Status: Indicates the current status of the cell, which is critical for accurate measurements. The status may display as under temperature, over temperature and stable temperature using the following icons:

	Indicates the cell temperature is over the setpoint
	Indicates the cell temperature is under the setpoint
	Indicates the cell temperature is at the correct level

3. Background Gas Name: Displays the name of the background gas mixture.

4.3 The About Menu

The “About” menu provides the device information to the user. It provides the following information:

1. Device name
2. Part number (configuration string)
3. Serial number
4. Firmware version
5. Safety firmware version
6. Boot loader version

About	
Device	▲
Part Nr	
Serial Nr	▼

About	
FW Version	▲
SFW Version	
BL Version	▼

4.4 Login Menu

The “Login” menu provides the operator with two functionalities:

1. Log on to the unit
2. Change the password for a user profile
3. Logout

Login
Password Login Change Password Logout

The unit comes configured with 3 different user access levels (see figure below). Each level defines the information the different users can access and edit, i. e., the different levels of read-only and read-write privileges. For instance, the user profile can only configure some device level parameters like the contrast but cannot configure a “Field Cal” whereas an admin profile can configure a “Field Cal” but can also adjust the contrast level of the device. The following are the profile options available:

1. User
2. Admin
3. SIL User (ONLY SIL Device)

Login As
User Admin SIL User

For every wrong password attempt a cooldown time is activated which starts at 3 seconds and doubles for every subsequent wrong password attempt. The cooldown time will reset after a successful password login.

Symbol	Key on Unit
▲	Up Key
▼	Down Key
◀	Left Key
▶	Right Key

Note: The logging in takes the device offline and enters the configuration mode. The customer must be logged in to return to online mode and resume measurement.

4.4.1 Login as User

To log in as a user to the device, go to the logins menu and select “Login As”. You will be provided with 3 options, select “User”. Now the unit will prompt the password for that profile. Enter the password and press OK. If login is successful, you will be redirected to the dashboard screen and you will see an open padlock icon with the number 1 in it, indicating “USER” profile login. In the case the password is incorrect you will be prompted with a “Login Error” screen and will be redirected to the login screen.

Note: The default user profile password is “▲▲▲▲▲▲▲▲” (eight times up key). The customer can initially login in with this password and make use of the change password feature to set an alternate password. Customers are advised to change the default passwords upon initial commissioning. Refer to the local cyber security guidelines.

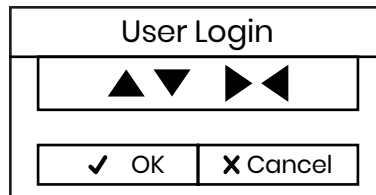

4.4.2 Login as Admin

To log in as an admin to the device, go to the logins menu and select “Login As”. You will be provided with 3 options, select “Admin”. Now the unit will prompt the password for that profile. Enter the password and press OK. If login is successful, you will be redirected to the dashboard screen and you will see an open padlock icon with the number 2 in it, indicating “ADMIN” profile login.

Note: Note: the default Admin Profile password is “▲▼▲▼▲▼▲▼” (up and down keys four times). The user can initially login in with this password and make use of the change password feature to set an alternate password. Customers are advised to change the default passwords upon initial commissioning. Refer to the local cyber security guidelines.

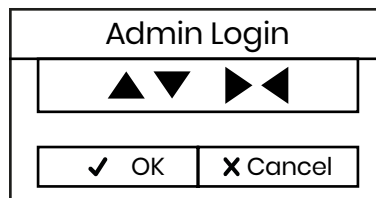

4.4.3 Login as SIL User (SIL ONLY)*

The SIL User profile is a special access that enables proof tests on the unit. The SIL user login works differently than the other two profiles. To log in as SIL User refer to calibration sheet for password.

Enter the password and if password validation is successful, you will be redirected to the dashboard with an open padlock icon with the number 3 in it, indicating the “SIL USER” profile.

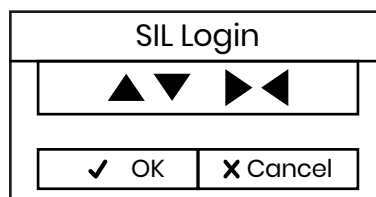

* Check the configuration string on the XMTCpro enclosure label if the analyzer has the SIL option.

Note: The password for the SIL User profile can be found in the calibration datasheet.

4.4.4 Change Password

The Change Password menu lets you change the password for the “USER” or “ADMIN” profile for the unit. To change the password for a specific profile you need to be logged in first. In case, you are not logged in and try to change the password you will be presented with a “LOGIN FIRST” error screen.

Once you are on the change password screen, you will be presented with two text boxes, where you enter the new password in the first text box and enter the new password again in the second text box to validate it. If both passwords match, then the password change is successful, and you will be redirected to the dashboard.

4.5 Error Handling/Alarms

Alarms are signaled via the alarm relays and both 4-20 mA outputs. Each alarm can be ignored on the relays and secondary 4-20 mA output, and specific mA levels can be associated with the secondary 4-20 mA output.

There is an options/button in the above window for each of the following error conditions:

1. Total Drift Err
2. Drift/Cal Err
3. Gas mV under range
4. Gas mV over range
5. Gas % under range
6. Gas % over range

To configure the XMTcpro's response to any of the above error conditions, click on the corresponding button in the window above and proceed to the appropriate section for instructions.

Table 2: Alarm relays and error conditions

No.	Error	Default mA	Alarm Relays	Meaning
1	Watchdog Err	21 mA	HH Alarm	Firmware is unresponsive
2	Heat Err	21 mA	HH Alarm	Heater hardware fault detected
3	ADC Err	21 mA	HH Alarm	Input hardware fault detected
4	DAC Err	21 mA	HH Alarm	Output hardware fault detected
5	MCU Err	21 mA	HH Alarm	Firmware has hard faulted
6	Data Er	21 mA	HH Alarm	Unrecoverable data loss detected
7	Brownout Err	3.6 mA	HH Alarm	Power supplied is not sufficient
8	Temp Over	20.5 mA	H Alarm	Cell is too hot (normal during warmup)
9	Temp Under	3.8 mA	H Alarm	Cell is warming up (Normal during warmup)
10	Early Over	20.5 mA	L Alarm	Gas% is below early low trip point
11	Early Under	3.8 mA	L Alarm	Gas% is above early high trip point
12	Gas Over	21 mA	LL Alarm	Gas% is above alarm high trip point
13	Gas Under	3.6 mA	LL Alarm	Gas% is below alarm low trip point
14	Cal Err	21 mA	HH Alarm	Calibration corrections cannot be applied
15	Sys Error	21 mA	HH Alarm	System fault detected

The early under, early over, gas under and gas over alarms are associated with trip points and will trigger when the gas% exceeds the specified trip point. See *Figure 11* to determine how Early low/high alarms and trip points function.

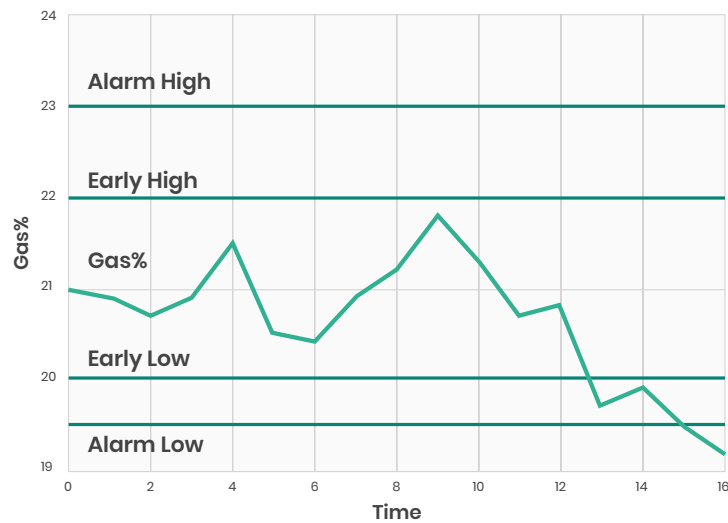
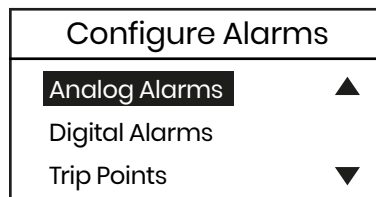
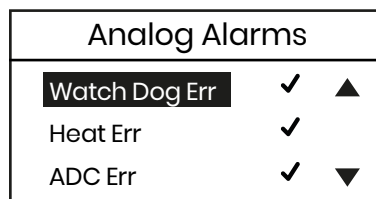

Figure 11: Early low/high alarms and trip points function

The “Alarms” menu allows you to configure error handling for specific error conditions for the XMTcpro. When you click on the alarms menu from the main menu a window as shown in the figure below opens. Clicking on any option opens the window for that option.



The “Analog Alarms” menu allows you to enable or disable error handling for the secondary 4-20 mA output for each specific error conditions for the XMTcpro. When you click on the alarms menu from the main menu a window as shown in the figure below opens. Clicking on any option opens the window for that option.



There is an options/button in the above window for each of the following error conditions listed in *Table 2*. To configure the XMTcpro's response to any of the listed error conditions, click on the corresponding button in the window above and proceed to the appropriate section for instructions.

4.5.1 Analog Alarms

The “Analog Alarms” menu lets you enable or disable error handling for the secondary 4-20 mA output. If you disable the alarm, it will not be signaled via the secondary 4-20 mA output.

Watch Dog Err	
• mA Enable ▲	
mA Disable ▼	

If you click on “mA Enable”, the following window opens.

Watch Dog Err	
4.56 mA	
0.00 to 24.00	
✓ OK	✗ Cancel

Enter the desired error mA output in the text box and click on enter to confirm the entry. The mA value set is a threshold and if the unit exceeds that the alarm will be triggered. You are then redirected to the “Alarms” menu.

4.5.2 Digital Alarms

The Digital Alarms option lets you enable or disable error handling for alarm relays. The corresponding windows are shown below.

Digital Alarms		Watch Dog Err	
Watch Dog Err ✓ ▲		• Enable ▲	
Heat Err ✓		Disable ▼	
ADC Err ✓ ▼			

Once the error condition is selected, if you click on enable, the error condition will be signaled via the alarm relays. You are then returned to the error handler window.

4.5.3 Trip Points

The “Trip Points” option lets you specify the gas% alarm trip points.

Trip Points		Alarm High	
Alarm Low ▲		4.56 %	
Alarm High ▼		-20 to 120	
Early Low ▼		✓ OK	✗ Cancel

If you click the trip points, the window displays a text box as shown in the figure above. Enter the desired gas% beyond which the alarm should trip into the text and click on the next item/enter to confirm the entry. The gas% set is a threshold and if the unit exceeds that the alarm will be triggered. You are then returned to the error handler window.

4.6 Display Config

The “Display Config” menu gives the operator 4 options to customize the display. The menu can be found under the “Config” menu from the main menu.

1. Invert Display (invert the coloring scheme)
2. Contrast (adjust the contrast)
3. Language (change the language version)
4. Units (change unit system)

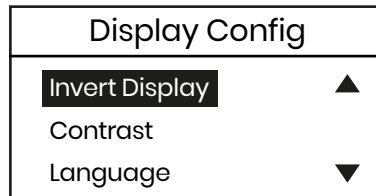

4.6.1 Contrast Settings

To adjust the contrast settings of the LCD display, navigate to the “Config” menu and select “Display Config” Select “Contrast” and the below screen should appear:

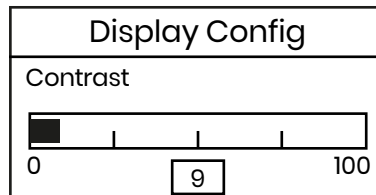

Use the left/right arrow keys on the unit to decrement/increment the contrast of the LCD. When done press Enter.

4.6.2 Invert Display

The LCD has the capability to invert its colors from black to blue and vice versa. To toggle between the 2 modes, select the invert display option from the “Display Config” menu and click OK.

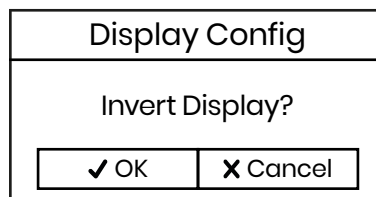

4.6.3 Units

The feature enables customers to toggle between metric and imperial unit systems for parameter readings. For example: Cell Temperature in Celsius (metric) or Fahrenheit (imperial). By default, the unit system is metric, but the user has the flexibility to switch between the two-unit systems whenever desired.

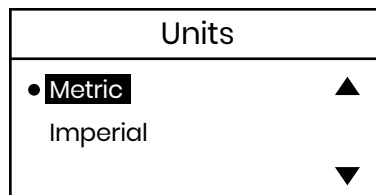

4.7 Modbus Parameters

The Modbus Parameters provides the following configurable parameters to the operator:

1. Mode
2. Port
3. Slave ID
4. Baud Rate
5. Parity
6. Stop Bits

Modbus Param	
Modbus Port	▲
Slave ID	
Baud Rate	▼

4.7.1 Mode

Enable or disable modbus on the unit. When enabled modbus parameters cannot be configured. To configure any of the following parameters, disable modbus and change the desired parameter.

Modbus Mode	
Enable	▲
• Disable	▼

4.7.2 Port

Modbus communications is available through any of the following interfaces. You can select one of the following through the HMI:

1. RS232
2. RS485

Modbus Port	
• RS232	▲
RS485	▼

4.7.3 Slave ID

Modbus slave ID can be set using the modbus parameters menu between 1 and 247.

Slave ID	
10	
0 to 247	
✓ OK	✗ Cancel

4.7.4 Baud Rate

The unit supports different baud rates for modbus communications. You can select from the options below:

1. 9600
2. 14400
3. 19200
4. 68400
5. 57600
6. 115200

Baud Rate	
Baud Rate	
	115200

4.7.5 Parity

The unit supports three parity options for modbus:

1. Odd
2. Even
3. None

Parity	
<input checked="" type="radio"/> Odd	▲
<input type="radio"/> Even	
<input type="radio"/> None	▼

4.7.6 Number of Bits

There are two options for stop bits:

1. 7
2. 8

# of Bits	
<input checked="" type="radio"/> 7	▲
<input type="radio"/> 8	▼

4.8 Factory Reset

The factory reset menu is available under the “Config” menu and gives the operator two options:

1. Reset Previous – Restores the previous settings for the device.
2. Reset Original – Restore factory settings for the device. Power cycle the unit for Reset original to take full effect.

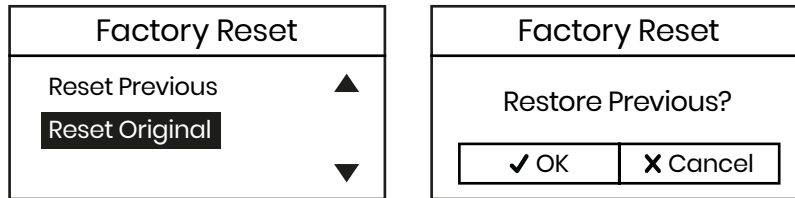

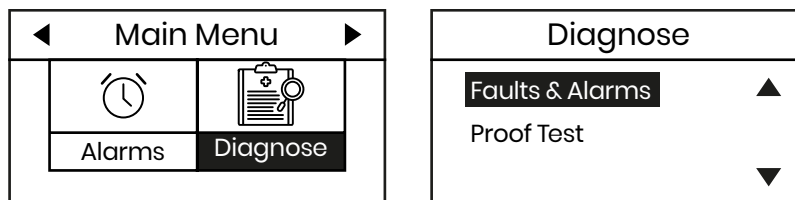

4.9 Faults and Alarms

The faults and alarms menu provides the operator with a summary of the alarms that are enabled, tripped, or disabled during device operation. The “Faults & Alarms” menu can be found under “Diagnose” menu.



The following icons indicate the operation of alarms:

Icon	Operation
	Alarm Enabled
	Alarm Disabled
	Alarm Tripped

4.10 Proof Tests (SIL Only)

Proof tests allow you to stress test the device to maintain your SIL certification. The “Proof Tests” menu can be found under the “Diagnose” menu. The menu provides you with the following options:

1. Proof Test Mode
2. Test Solenoids
3. Test Relays
4. Test NAMUR
5. Test Alarms
6. Test CH1
7. Test CH2

To enable proof tests select “Proof Test Mode” and click Enable.

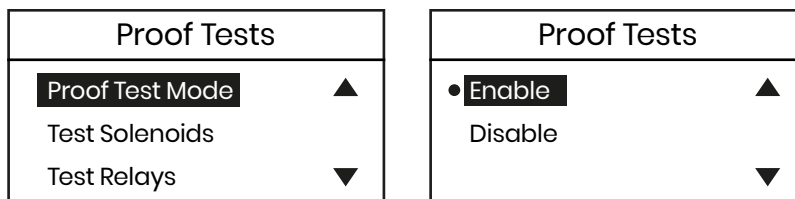

IMPORTANT: Before conducting Proof Tests, notify the control room to disconnect the SIL output from the safety instrumented system (SIS). Upon completion of Proof Testing notify the control room to enable the instrument again in the SIS.

4.10.1 Test Solenoids

The menu provides you the option to test either both solenoids on the unit or test either one at a time. The menu provides four options to test solenoids:

1. SOL_NONE
2. SOL 1
3. SOL 2
4. SOL BOTH

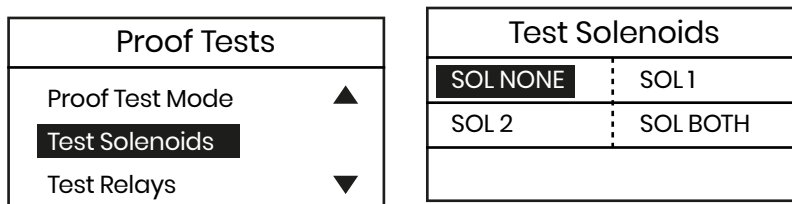

4.10.2 Test Relays

The menu provides you the option to test the relays on the unit. The menu provides four options to test the relays:

1. Relay LL (Low-Low)
2. Relay L (Low)
3. Relay HH (High-High)
4. Relay H (High)
5. Relay H2G1

6. Relay H2G2

Proof Tests		Test Relays	
Proof Test Mode	▲	Relay LL	Relay L
Test Solenoids		Relay H	Relay HH
Test Relays	▼	Relay H2G 1	Relay H2G 2

4.10.3 Test NAMUR

The menu provides you the option to test the NAMUR on the unit. The menu provides four options:

1. NAMUR LL (Low-Low)
2. NAMUR L (Low)
3. NAMUR HH (High-High)
4. NUMAR H (High)

Proof Test		Test Namur	
Test NAMUR	▲	NAMUR LL	NAMUR L
Test Alarms		NAMUR H	NAMUR HH
Test 4-20 mA Out1	▼		

4.10.4 Test Alarms

The menu provides an option to test all 15 alarms as mentioned in Section 4.5. Select the alarm you want to test and click enable.

Proof Test		Test Alarms	
Test NAMUR	▲	Watch Dog Err	▲
Test Alarms		Heat Err	
Test 4-20 mA Out1	▼	ADC Err	▼

4.10.5 Test 4-20 mA Out1

The option lets you test the 4-20 mA outputs for Channel 1. Select the “Test 4-20 mA Out1” option from the proof test menu, click enable, and enter the mA value to test.

Proof Test		Test 4-20 mA Out1	
Test 4-20 mA Out1	▲	8.01	mA
Test 4-20 mA Out2	▼	0.00	to 24.00
		✓ OK	✗ Cancel

4.10.6 Test 4-20 mA Out2

The option lets you test the 4-20 mA outputs for Channel 2. Select the Test 4-20mA Out2 option from the proof test menu, click enable, and enter the mA value to test.

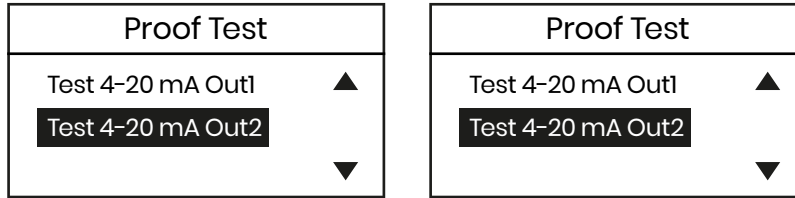

[no content intended for this page]

Chapter 5. Programming with Modbus

The modbus communications protocol allows you to read/write data and log/view real-time and diagnostic data in numeric formats.

Note: Be sure you have properly installed Modbus Client Software on your PC before attempting to program the XMTCpro.

5.1 Login

The XMTCpro comes configured with 3 profiles (below) and each profile has different levels of Read-Only and Read-Write privileges. For instance, the User profile can only configure some device level parameters like the contrast but cannot configure a Field Cal whereas an Admin Profile can configure a Field Cal but can also adjust the contrast level of the device. The following are the profile options available:

Profile	USER_ID
User	1
Admin	2
SIL User	3

5.1.1 Login as User

To log in as a user over modbus write to the register "USER_ID" as set ID as 1. Refer table above. Write the password to the register "PWD_LOGIN". If validation is successful, you will receive a status "OK" from the modbus client.

Note: The default User Profile password is "7951". The customer can initially login in with this password and make use of the change password feature to set an alternate password. Customers are advised to change the default passwords upon initial commissioning. Refer to the local cyber security guidelines.

5.1.2 Login as Admin

To log in as an admin over modbus write to the register USER_ID and set it to 2. Refer table above. Write the password to the register "PWD_LOGIN". If validation is successful, you will receive a status "OK" from the modbus client.

Note: The default AdminProfile password is "7852". The customer can initially login in with this password and make use of the change password feature to set an alternate password. Customers are advised to change the default passwords upon initial commissioning. Refer to the local cyber security guidelines.

5.1.3 Login as SIL User (SIL ONLY)

The SIL User profile is a special access that enables proof tests on the unit. The SIL user login requires a password which is specific to the unit and cannot be changed. To log in as an SIL User do the following:

Acquire the password, write the same password to register "PWD_LOGIN". If validation is successful, you will receive a status "OK" from the modbus client. (Refer to modbus map in the appendix for register information).

5.2 Change Password

To change the password of a certain user profile, ensure you are logged in using the respective profile. Post that, write the new desired password into the register "PWD_CHANGE". If the modbus responds with an OK, the password has been changed successfully.

5.3 Error Handler/Alarms

The Alarms menu allows you to configure the way the XMTcpro responds to various error conditions. Refer to the modbus map below to access XMTcpro alarms.

To enable/disable an alarm you need to write to the "ANALOG_ALARMS_EN" register which is a bit mask to enable alarms. Once the alarm is enabled you can set the mA value of the alarm for it to trip.

There is a register in the map for each of the following error conditions:

Register	Alarm
ALARM_01_MA	Total Drift Err
ALARM_02_MA	Drift/Cal Err
ALARM_03_MA	Gas mV under range
ALARM_04_MA	Gas mV over range
ALARM_05_MA	Gas % under range
ALARM_06_MA	Gas % over range

To program for all the XMTcpro error conditions listed above, simply write to register corresponding to the alarm you want to program. Enter the mA output within the range provided in the modbus map that you wish to have generated in the event of an error.

Chapter 6. Calibration with HMI

6.1 Preparing the XMTCpro for Calibration

1. Connect the zero gas to the zero gas inlet on the sample system or other gas control system to the XMTCpro.
2. Establish a flow rate of 250 cc/min (0.5 SCFH) of zero gas at 0.0 bar(g)/0.0 MPa(g) to the XMTCpro.
3. Allow for the reading to settle. This can take up to 15 minutes.
4. Proceed to *Section 6.2, Test and Trim* if 4-20mA channel requires test & trim, if not proceed to *Section 6.3, The Field Cal Menu*.
5. If conducting 2 point calibration repeat steps 1 to 4 above with Span Gas connected.

Note: The calibration must be verified by testing zero and span gases. When verifying the analyzer, the expected value should be within the accuracy tolerance of 2% of span. If the calibration cannot be verified, then repeat the calibration.

Cal	
Field Cal	▲
Test & Trim	
H2G Func	▼

IMPORTANT: The calibration system can not verify that the calibration gas is connected to the correct inlet. It is the responsibility of the end user to verify the gas is connected to the correct inlet.

6.2 Test and Trim

The 4-20 mA Test and Trim enables you to modify the output so that the zero and span sent by the XMTCpro are received appropriately by an external device such as a recorder or digital multimeter.

The Trim function adjusts the zero and span output signals to match 4-20 mA on the receiving device. The Test function enables validation of the configuration by driving a user-selected mA output value to the 4-20 output and applying the updated Trim configuration before saving it.

To execute a Trim, select the Test and Trim option under the Cal Menu. It will show you the following options:

1. Channel Select - Determines which channel the Trim will be applied to.
2. Trim - Initiates the Trim function workflow.
3. Test - Assigns the value for testing the Trim setup.
4. Discard Trim - Discards the current Trim configuration.
5. Save Trim - Persists the current Trim configuration.

Test & Trim	
Channel Select	▲
Trim	
Test	▼

6.21 Channel Select

Choose “4-20mA Out1” or “4-20mA Out2” to apply any required Trim.

Channel Select	
4-20 mA Out1	▲
● 4-20 mA Out2	
	▼

6.22 Trim

Initiates the Trim workflow by requesting numerical inputs in the designated sequence for the following parameters:

1. Set Zero mA - Desired Zero Point
2. Set Measured Zero mA - Measured Zero Point
3. Set Span mA - Desired Span Point
4. Set Measured Span mA - Measured Span Point

After completing the workflow above, you will be redirected to the Test Menu.

Set Zero mA	
21.40	mA
0.00	to 24.00
✓ OK	✗ Cancel

Measured Zero mA	
21.20	mA
-48.00	to 48.00
✓ OK	✗ Cancel

6.23 Test

Enabling test mode, activates the newly configured trim setting temporarily. It will prompt you to enter a mA value which will be trimmed according to the new trim setting. You can verify the operation of the new trim value using a multimeter or recorder in Test Mode. If the signal is not satisfactory, you can delete the configuration using discard trim or save it, if it is satisfactory.

Test	
Set mA (Simulated)	▲
	▼

Set mA (Simulated)	
21.10	mA
0.00	to 24.00
✓ OK	✗ Cancel

6.2.4 Discard Trim and Save Trim

Discards/Saves the current Trim configuration.

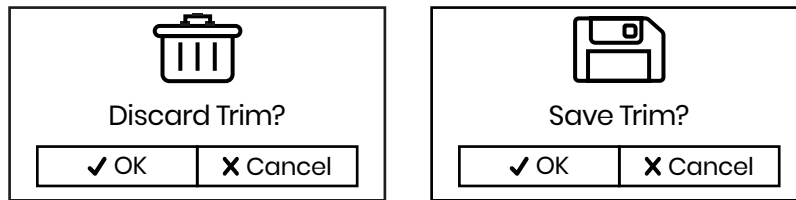

6.3 The Field Cal Menu

When you select the Field Cal option, the following window opens:

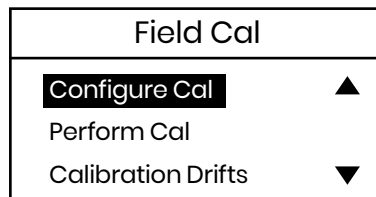

The Field Cal options offers the following 7 choices:

1. Configure Cal - Sets the calibration type and parameter
2. Perform Cal - Calibrates the XMTCpro
3. Calibration Drifts - Lists drift percentages for zero and span gases
4. Hold Last Value - Holds the last value calibrated
5. Abort Cal - Aborts the in progress of the field calibration
6. Clear Cal - Clears the last calibration
7. Save Cal - Saves current calibration to flash memory

Note: Clicking on the Next Item/Enter button selects the option listed on the status line above the option buttons (Perform Cal in figure above). The option listed on the status line in any window is the option that was chosen the last time that menu was used.

Clicking on any of the above choices opens a new window that allows you to perform that function. Proceed to the appropriate section for a detailed description of each option.

Note: Calibrations can not be performed online. You must login as Admin which takes the meter offline.

6.3.1 Configure Cal

The Configure Cal option enables you to change the field calibration type and various calibration parameters. Clicking on the Configure Cal button opens the window below:

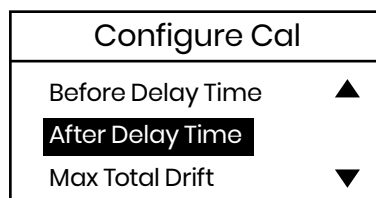

Click on the desired option button and proceed to the appropriate section for a discussion of that option.

6.3.1.1 Field Cal Type

A typical Field Cal Type window is shown below:

Field Cal Type	
1 Point (Offset) ▲	
2 Point (Zero/Span) ▼	

IMPORTANT: The factory setting is the 2-point (Zero/Span) calibration type.

Click on the appropriate button to select the desired calibration type. Then, click on any button on the right to return to the Configure Cal window.

6.3.1.2 Field Cal percent

There are two field percent options available under the Config Cal Menu:

- 1 Zero Field Cal
- 2 Span Field Cal

The above options are used to specify the oxygen percentages of the zero and span calibration gases that will be used. The recommended gases are listed on the XMTcpro Calibration Data Sheet. Click on the Zero Field Cal button to enter the percentage of signal gas in your zero gas. The following window opens:

Zero Field Cal	
21.00 %	
0.00	to 100.00
✓ OK	✗ Cancel

Type the zero-gas percentage in the text box, and click the Enter button to confirm the entry (click the Previous Item or Exit Page button to leave the window without changing the existing percentage)

IMPORTANT: The factory setting for zero and span gas are included in the calibration datasheet.

Repeat the above procedure to enter your span calibration gas percentage. Then, click on any button on the right to return to the Configure Cal window.

6.3.1.3 Before Delay Time

Clicking on the Before Delay Time button opens the window below. Entering a before delay time will set it for both zero and span calibration points.

Enter the desired zero/span point before delay time, in minutes and seconds, in the text box. Then, click on the Next Item/ Enter button to confirm the entry (click the Previous Item or Exit Page button to exit the window without changing the existing value).

Before Delay Time	
11:34	
MM:SS	
✓ OK	✗ Cancel

6.3.1.4 After Delay Time

Repeat the procedure in the above section to set the after-delay time for both the zero and span points.

6.3.1.5 Max total drift

Max Total Drift is the maximum total calibration drift allowable, expressed as a percentage of the full-scale reading. Selecting this option opens the following window:

Max Total Drift	
34.00	
-1000.00	to 1000.00
✓ OK	✗ Cancel

Enter the desired percentage of the full-scale reading in the text box, and click the Next Item/Enter button to confirm the entry (click the Previous Item or Exit Page button to leave the window without changing the existing percentage).

Note: To calculate Max Drift see Appendix K. Max Drift Calibration.

6.3.2 Perform Cal

Clicking on the Perform Cal button opens the following window:

Perform Cal	
Zero Field Cal	▲
Span Field Cal	▼

Click on the “Zero Field Cal” button to calibrate the zero point or on the “Span Field Cal” button to calibrate the span point.

Click Yes to perform the calibration, or “Abort Field Cal” to stop the calibration and return to the previous menu. The result of a completed calibration is shown with the “Cal ready” notification screen. To calibrate the next span point, after the “Cal ready” screen appears, press the back key, select “Span Field Cal” and press enter.



6.3.3 Calibration Drifts

The Calibration Drifts option enables you to view the current calibration drift at both the zero and span points since the last calibration was performed. Clicking on this button opens the following window:

Calibration Drifts		
	Zero	Span
Drift Prev.	21.00	3.00
Drift Fact.	54.00	67.00

Click on any button to return to the main Field Cal window.

6.3.4 Hold Last Value

In addition to performing a field calibration or configuring the calibration parameters, you can program the XMTcpro to hold the last calibrated value. To perform this task, click on the “Hold Last Value button”. You will notice that the text on the button now reads “Disable Hold Last”. To cancel the Hold Last Value programming, just click on this new button. You can toggle between the two states for this parameter by clicking on this button (remember that the current state is the one NOT written on the button).

Hold Last Value	
Disable Hold Last?	
✓ OK	✗ Cancel

6.3.5 Abort Cal

Click on the Yes button to abort the in progress calibration, or click on the Cancel, Previous Item, or Exit Page button to close the window without aborting the most recent calibration.

Abort Cal	
Abort Cal?	
✓ OK	✗ Cancel

6.3.6 Clear Cal

Click on the Yes button to clear the most recent calibration, or click on Cancel, Previous Item, or Exit Page button to close the window without clearing the most recent calibration. If you click on the Yes button, the confirmation screen window opens.

Clear Cal	
Yes?	
✓ OK	✗ Cancel

6.3.7 Save Calibration

On selecting “Save Cal”, the following window opens:

	
Save Cal?	
✓ OK	✗ Cancel

Clicking OK, will save the current calibration and persist to flash memory. If the save operation is successful, you will see a notification screen as the figure below.



Else, if the operation fails, you would see a screen as the figure below:



To verify a calibration, the procedure should check for 2-3 points in the calibrated range. This is to ensure that the new calibration has been persisted in flash. Repeat the calibration until the verification is completed or using the restore calibration function to revert to the last validation calibration.

6.4 Hydrogen Cooled Generator Functions (H2G Only)

The H2G menu can be found under the Calib menu. The XMTCpro lets you configure the Hydrogen Cooled Generator active curve and gives you three options. The active curve is indicated with both calibration relays (SOL1 and SOL2) and on the secondary 4-20 mA output as per the table below.

Table 3: H2G Active Curve Configuration

Phase	Gases	CH1	CH2	SOL1	SOL2	Comment
1	H2/Air	H2 as 4-20 mA	8 mA	LOW	LOW	Normal Operation
2	H2/CO2	CO2 as 4-20 mA	12 mA	HIGH	LOW	Purge with H2
3	Air/CO2	Air as 4-20 mA	16 mA	LOW	HIGH	Introduce Air

The HMI will give you three options to select the active curve as indicated in the figure below.

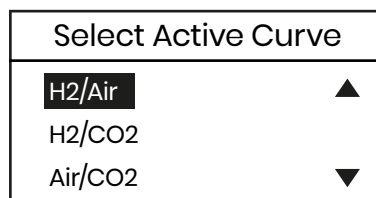

Once, you select the active curve you will be redirected to the Active Curve Indicator screens where you can see the Gas % for the curve selected.

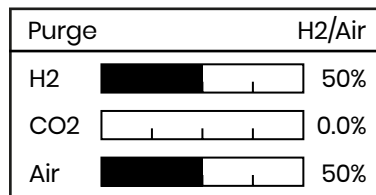

Depending upon the gas mixture selected, the percentage values of the gases will be displayed on the screen. For example, if purge for H₂/Air is selected - the data will be displayed using the H₂ and Air bar graphs and the third bar graph will always display 0.

The range for the H₂/Air curve is configurable and will scale the primary 4-20mA output.



WARNING! Alarm High/Low and Early High/Low Trip Points are inactive when purging with CO₂ or when introducing Air.

Chapter 7. Calibration with Modbus

7.1 Test and Trim

The Trim procedure can be configured over modbus as follows:

- 1.** TRIM_CH: Channel Select (Ch 1 or Ch 2) to apply the Trim configuration.
- 2.** TRIM_MA: Enter the desired mA value.
- 3.** TRIM_MEASURED: Enter the measured mA value.
- 4.** TRIM_SAVE:
 - a.** Write 0 to discard Trim.
 - b.** Write 1 to persist Trim.
 - c.** Write 4 to save the Trim point for 4 mA.
 - d.** Write 20 to save the Trim point for 20 mA.
 - e.** Write 12 to activate and enter "Verify Mode".

The workflow will be as follows:

- 1.** Select the desired channel by writing to "TRIM_CH".
- 2.** Enter the desired 4 mA point in "TRIM_MA".
- 3.** Enter the measured mA for the 4-mA point in "TRIM_MEASURED".
- 4.** Save the 4-mA point by writing 4 to "TRIM_SAVE".
- 5.** Enter the desired 20 mA point in "TRIM_MA".
- 6.** Enter the measured mA for the 20-mA point in "TRIM_MEASURED".
- 7.** Save the 20-mA point by writing 20 to "TRIM_SAVE".
- 8.** Enter verify mode by writing 12 to "TRIM_SAVE".
- 9.** Now, test the new Trim configuration by writing test values in "TRIM_MA" and validate them.
- 10.** If you are satisfied with the Trim configuration enter 1 to "TRIM_SAVE".
- 11.** To discard it, write 0 to "TRIM_SAVE".

7.2 Field Calibration

The field calibration or field cal for the unit can be done via modbus as follows.

1. CAL_CONFIG: Select the cal type (1 Point or 2 Point).
2. CAL_SOLENOIDS: Select the solenoid for the Cal.
3. CAL_ZERO: Specify the gas percentages of the zero gas.
4. CAL_SPAN: Specify the gas percentages of the span gas.
5. CAL_SAVE:
 - a. Write 1 to record zero gas.
 - b. Write 2 to record span gas.
 - c. Write 3 to go into Verify Mode.
 - d. Write 4 to persist data to flash.
6. Once, you save the cal, the field calibration process will start, and you should see the gas % reading stabilize in the "GAS_PC_STABILITY" register.

To verify a calibration, the procedure should check for 2-3 points in the calibrated range. This is to ensure that the new calibration has been persisted in flash. Repeat the calibration until the verification is completed or using the restore calibration function to revert to the last validation calibration.

7.3 Hydrogen Cooled Generator Functions (H2G Only)

The XMTCpro can be used to measure the purity of hydrogen (H₂) in hydrogen-cooled electricity generators used in the power industry.

The H2G phase can be calibrated for the XMTCpro over modbus using the following options:

1. H2G_PHASE: Select the gas mixture (H₂/Air, Air/CO₂, H₂/CO₂).
2. H2G_AIR_PC: Reads out 100% Air mA reading.
3. H2G_H₂_PC: Reads out 100% H₂ mA reading.
4. H2G_CO₂_PC: Reads out 100% CO₂ mA reading.

Depending upon the gas mixture selected, you can look at the specific mixtures to look at the values for the gas mixture. For example, if purge for H₂/Air is selected – the data will be displayed using the H₂ and Air registers and the third register will always display 0. Refer to the below table for details of the effects of the selected phase.

Phase	Gases	CH1	CH2	SOL1	SOL2	Comment
1	H ₂ /Air	H ₂ as 4-20 mA	8 mA	LOW	LOW	Normal Operation
2	H ₂ /CO ₂	H ₂ as 4-20 mA	12 mA	HIGH	LOW	Purge with H ₂
3	Air/CO ₂	Air as 4-20 mA	16 mA	LOW	HIGH	Introduce Air



WARNING! Alarm High/Low and Early High/Low Trip Points are inactive when purging with CO₂ or when introducing Air.

Chapter 8. Specifications

8.1 Functional

Functional Safety	IEC61508 SIL 2 (optional)
Analog Output	Two 4 to 20 mA isolated, 550Ω maximum load, field-programmable
Digital I/O	Modbus RS232/RS485
Power	24.0 VDC ±4 VDC 1.5A maximum
Ambient Operating Temperature Range	2 options: Option 1: -20°C to +50°C (+14°F to +122°F) Option 2: -5°C to +65°C (+23°F to +149°F)
Storage Temperature	-20°C to +65°C (-4°F to +149°F)
Keypad	Magnetic, through the glass, six buttons
Display	Backlit liquid crystal display
Relay outputs	Contact ratings: 2 A, 28 VDC, SPDT Non-latching, 1x failsafe, 3x non-failsafe

8.2 Performance

Accuracy:	±2% of span
Linearity:	±1% of span
Repeatability:	±0.5% of span
Stability Zero:	±0.5% of span per week
Span:	±0.5% of span per week
Response Time:	20 seconds for 90% of step change Optional: <10 seconds for hydrogen, <20 seconds for selected gases (consult factory)
Measurement Ranges (Typical):	<ul style="list-style-type: none"> • 0-1% • 0-2% • 0-5% • 0-10% • 0-25% • 0-50% • 0-100% • 50-100% • 80-100%

Measurement Gases (Typical):	• 90–100%
	• 95–100%
	• 98–100%
	• H ₂ in N ₂ , air, O ₂ or CO ₂
	• He in N ₂ or air
	• CO ₂ in N ₂ or air
	• SO ₂ in air
	• Ar in N ₂ or air
	• H ₂ /CO ₂ /air for hydrogen-cooled generators

Required Sample Flow Rate: 0.1 to 4.0 SCFH (10 to 2000 cc/min),
0.5 SCFH (250 cc/min) nominal

8.3 Physical

Sensor Wetted Materials	Standard: 316 Stainless Steel, glass, and Viton® O-rings Optional: Hastelloy C276 glass and Chemraz™ O-rings
Dimensions	Weatherproof unit (H x D x W): 228 x 178 x 142mm (9 x 7 x 6in) Explosion-proof unit (H x D x W): 252 x 178 x 142mm (10 x 7 x 6in) See <i>Figure 12</i> and <i>Figure 13</i>
Weight	Aluminum Version: 4.5kg / 9.9lb. Stainless Steel Version: 11kg / 24.2lb.
Connections	3/4in NPT (electrical) 1/4in NPTF (sample gas inlet/outlet)
Environmental	IP66, Type 4X
IECEX Compliance/ ATEX Compliance	Ex db IIC T6 Gb Ex tb IIIC T78°C Db -20°C < Tamb < +65°C
European Union Compliance	<ul style="list-style-type: none"> • EMC Directive 2014/30/EU: Class A, Group 1, Industrial Locations • ATEX Directive 2014/34/EU: II 2G & II 2D
NEC/CEC	<ul style="list-style-type: none"> • CI I,II,III Div 1 Groups A-G, T6 • CI I, Zn 1 AEx/Ex db IIC T6 Gb • CI II, Zn 2I AEx/Ex tb IIIC T78°C Db <ul style="list-style-type: none"> • 20°C < Tamb < +65°C (this temperature range applies to all bullet points above) • CI I, II, III Div 2, Groups ABCDEFG, T6/T5 <ul style="list-style-type: none"> • T6: 20°C < Tamb < +50°C • T5: 20°C < Tamb < +65°C

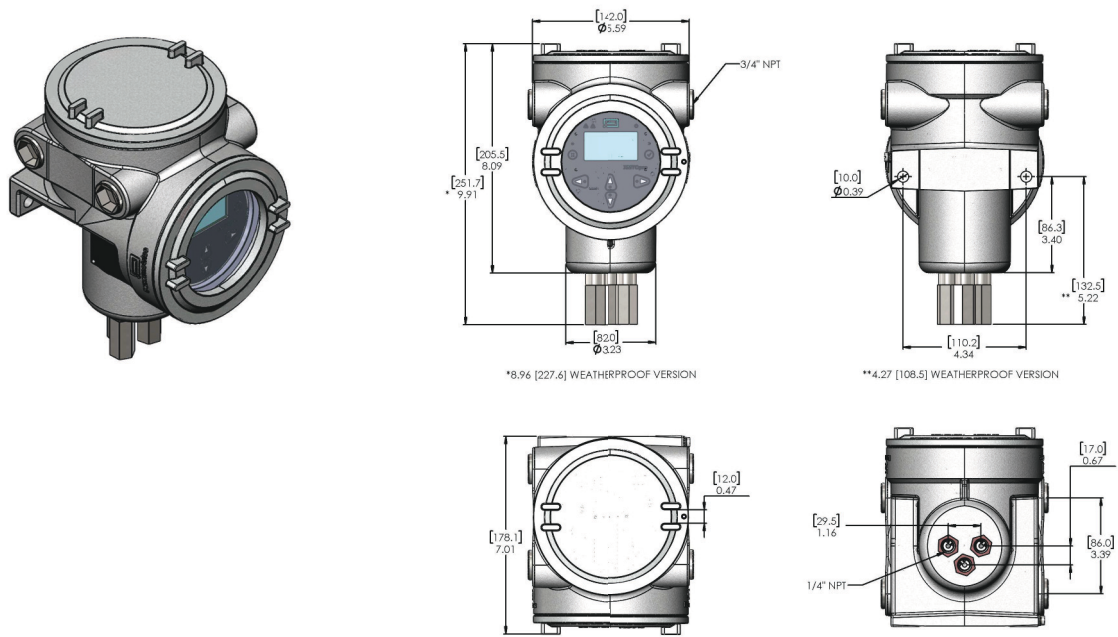

Figure 12: Aluminum Version Dimensions

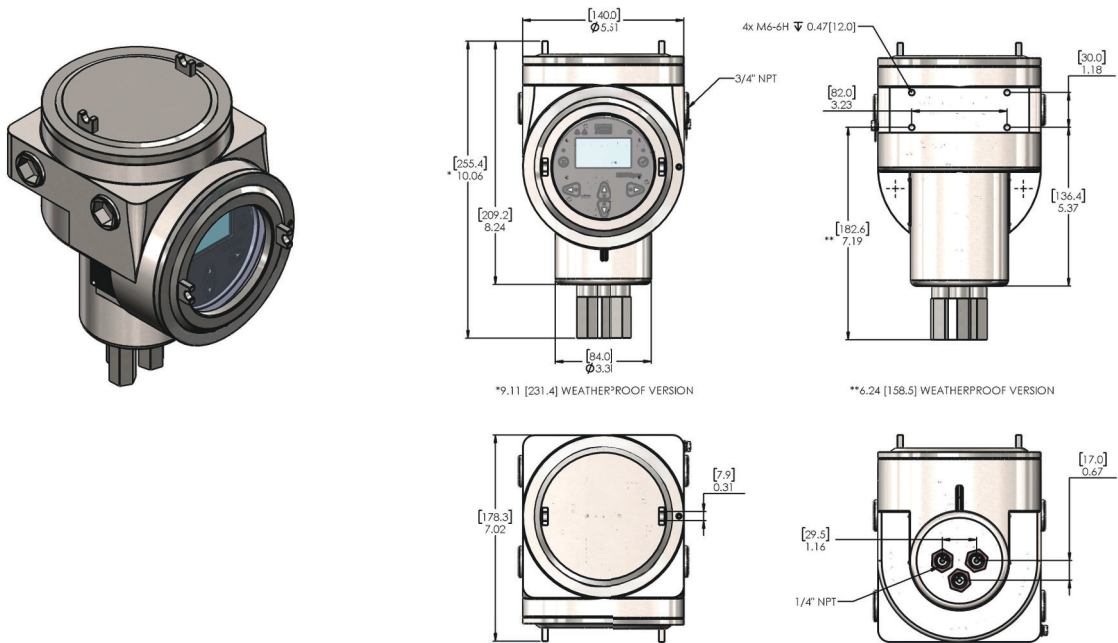

Figure 13: Stainless Steel Version Dimensions

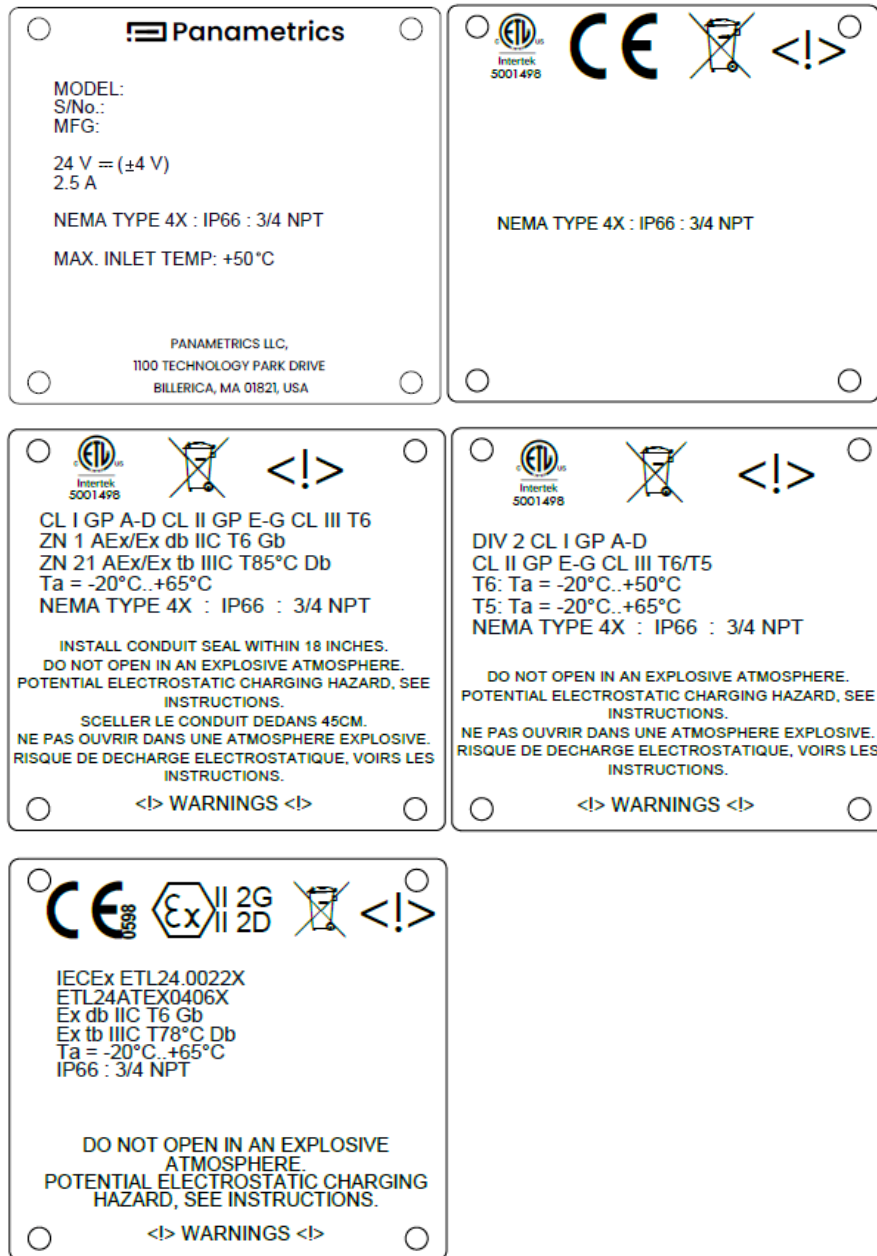

Figure 14: Certification and model labels for XMTcpro.

Chapter 9. Decommissioning

Upon completion of service, the analyzer shall be decommissioned (removed from service) by an authorized user.

9.1 Objective

Before decommissioning any safety system from active service, be sure a proper review is conducted and obtain any required authorization. Also, maintain appropriate safety functions during decommissioning activities.

Management of change procedures shall be implemented for all decommissioning activities.

9.2 Hazard and Risk Analysis to be Performed by the Customer

The impact of decommissioning on adjacent operating units and facilities or other field services shall be evaluated prior to decommissioning.

9.3 Disposal

Disposal shall comply with the Waste Electrical and Electronic Equipment Directive (WEEE Directive) at the following link: http://ec.europa.eu/environment/waste/weee/index_en.htm

Please contact our Customer Service using the following link <https://panametrics.com/support> or use the QR code present on the back cover to report a decommissioned product

[no content intended for this page]

Appendix A. Modbus Map

ADDRESS	NAME	TYPE	ACCESS	COMMENT
40000(DEC) C40(HEX)	RUNNING_TIME	U32	RO (Admin) RO (User)	Seconds since power on/reset
40002(DEC) 9C42(HEX)	MODBUS_ID	U16	RW (Admin) RO (User)	Modbus device identifier
40003(DEC) 9C43(HEX)	STATUS	U16	RO (Admin) RO (User)	3 digit codes
40004(DEC) 9C44 (HEX)	PRODUCT	U16	RO (Admin) RO (User)	Identifies the product model
40005(DEC) 9C45(HEX)	ALARM_STATES	U16	RO (Admin) RO (User)	Flags which indicate alarm is active
40006(DEC) 9C46(HEX)	UNITS	U16	RW (Admin) RW (User)	Unit systems
40007(DEC) 9C47(HEX)	CHI_GAS_PC	F32	RO (Admin) RO (User)	Primary gas %
40009(DEC) 9C49(HEX)	CH2_GAS_PC	F32	RO (Admin) RO (User)	User customized gas %
40013(DEC) 9C4D(HEX)	GAS_PC_STABILITY	F32	RO (Admin) RO (User)	Stability of the gas % reading
40015(DEC) 9C4F(HEX)	CELL_TEMP_SETPOINT	F32	RO (Admin) RO (User)	Target cell temperature
40017(DEC) 9C51(HEX)	CELL_TEMP	F32	RO (Admin) RO (User)	Cell temperature reading
40019(DEC) 9C53(HEX)	CELL_TEMP_STABILITY	F32	RO (Admin) RO (User)	Stability of the cell temperature
40021(DEC) 9C55(HEX)	AMBIENT_TEMP	F32	RO (Admin) RO (User)	Ambient temperature reading
40027(DEC) 9C5B(HEX)	CELL_XIMV	F32	RO (Admin) RO (User)	Bridge voltage
40033(DEC) 9C61(HEX)	CELL_PWRMV	F32	RO (Admin) RO (User)	Power supply
40035(DEC) 9C63(HEX)	CELL_TEMPMV	F32	RO (Admin) RO (User)	Cell temperature sensor
40037(DEC) 9C65(HEX)	AMBIENT_TEMPMV	F32	RO (Admin) RO (User)	Ambient temperature sensor
40039(DEC) 9C67(HEX)	POWER_VDC	F32	RW (Admin) RO (User)	20-28VDC power supply (24VDC nominal)
40041(DEC) 9C69(HEX)	DATE_YY	U16	RW (Admin) RO (User)	Year
40042(DEC) 9C6A(HEX)	DATE_MM	U16	RW (Admin) RO (User)	Month

ADDRESS	NAME	TYPE	ACCESS	COMMENT
40043(DEC) 9C6B(HEX)	DATE_DD	U16	RW (Admin) RO (User)	Day of month
40044(DEC) 9C6C(HEX)	DATE_WK	U16	RW (Admin) RO (User)	Weekday
40045(DEC) 9C6D(HEX)	TIME_HH	U16	RW (Admin) RO (User)	Hours
40046(DEC) 9C6E(HEX)	TIME_MM	U16	RW (Admin) RO (User)	Minutes
40047(DEC) 9C6F(HEX)	TIME_SS	U16	RW (Admin) RO (User)	Seconds
40048(DEC) 9C70(HEX)	CHI_RANGE_ZERO	F32	RO (Admin) RO (User)	Primary channel gas % lower limit
40050(DEC) 9C72(HEX)	CHI_RANGE_SPAN	F32	RO (Admin) RO (User)	Primary channel gas % upper limit
40052(DEC) 9C74(HEX)	CH2_RANGE_ZERO	F32	RW (Admin) RO (User)	Secondary channel gas % lower limit
40054(DEC) 9C76(HEX)	CH2_RANGE_SPAN	F32	RW (Admin) RO (User)	Secondary channel gas % upper limit
40056(DEC) 9C78(HEX)	TRIM_CH	U16	RW (Admin) RO (User)	Set channel for test and trim
40057(DEC) 9C79(HEX)	TRIM_MA	F32	RW (Admin) RO (User)	Set mA output to a known value
40059(DEC) 9C7B(HEX)	TRIM_MEASURED	F32	RW (Admin) RO (User)	Enter the value measured with a multimeter
40061(DEC) 9C7D(HEX)	TRIM_SAVE	U16	RW (Admin) RO (User)	Discard/Record/Persist test trim readings
40062(DEC) 9C7E(HEX)	CAL_CONFIG	U16	RW (Admin) RO (User)	Select a calibration type
40063(DEC) 9C7F(HEX)	CAL_SOLENOIDS	U16	RW (Admin) RO (User)	Remote operation of the calibration relays
40064(DEC) 9C80(HEX)	CAL_ZERO	F32	RW (Admin) RO (User)	Enter % from zero calibration gas
40066(DEC) 9C82(HEX)	CAL_SPAN	F32	RW (Admin) RO (User)	Enter % from span calibration gas
40068(DEC) 9C84(HEX)	CAL_SAVE	U16	RW (Admin) RO (User)	Save Field Cal data
40069(DEC) 9C85(HEX)	DRIFT_INDEX	U16	RW (Admin) RO (User)	Index into drift history
40070(DEC) 9C86(HEX)	DRIFT_TIMESTAMP	U32	RO (Admin) RO (User)	Time at which drift data was captured
40072(DEC) 9C88(HEX)	DRIFT_ZERO	F32	RO (Admin) RO (User)	Total drift from factory at zero point

ADDRESS	NAME	TYPE	ACCESS	COMMENT
40074(DEC) 9C8A(HEX)	DRIFT_SPAN	F32	RO (Admin) RO (User)	Total drift from factory at span point
40076(DEC) 9C8C(HEX)	H2G_PHASE	U16	RW (Admin) RO (User)	Select the purge phase in H2G applications
40077(DEC) 9C8D(HEX)	H2G_CO2_PC	F32	RO (User) RO (Admin)	CO ₂ concentration reading
40079(DEC) 9C8F(HEX)	H2G_AIR_PC	F32	RO (User) RO (Admin)	Air concentration reading
40081(DEC) 9C91(HEX)	H2G_H2_PC	F32	RO (User) RO (Admin)	H ₂ concentration reading
40083(DEC) 9C93(HEX)	H2G_CO2_MA	F32	RO (User) RO (Admin)	100% CO ₂ mA reading
40085(DEC) 9C95(HEX)	H2G_AIR_MA	F32	RO (User) RO (Admin)	100% Air mA reading
40087(DEC) 9C97(HEX)	H2G_H2_MA	F32	RO (User) RO (Admin)	100% H ₂ mA reading
40089(DEC) 9C99(HEX)	GAS_CONFIG	U16	RO (User) RO (Admin)	Configure gas
40090(DEC) 9C99(HEX)	GAS_IDX_BK	U16	RO (User) RO (Admin)	Gas background mixture index
40092(DEC) 9C9C(HEX)	GAS_IDX_PT	U16	RO (User) RO (Admin)	Gas point on curve
40093(DEC) 9C9D(HEX)	GAS_O2_PC	F32	RO (User) RO (Admin)	Specifies the signal gas%
40097(DEC) 9CA1(HEX)	GAS_O2_MV	F32	RO (User) RO (Admin)	
40099 (DEC) 9CA3 (HEX)	GAS_BK_MV	F32	RO (User) RO (Admin)	
40103 (DEC) 9CA7 (HEX)	GAS_TEMP_MV	F32	RO (User) RO (Admin)	
40105(DEC) 9CA9(HEX)	DIGITAL_ALARMS_EN	U16	RW (Admin) RO (User)	Bitmask to enable digital alarms
40106(DEC) 9CAA(HEX)	ANALOG_ALARMS_EN	U16	RW (Admin) RO (User)	Bitmask to enable analog alarms
40107(DEC) 9CAB(HEX)	ALARM_LOW_PC	F32	RW (Admin) RO (User)	Lower limit of the signal gas %
40109(DEC) 9CAD(HEX)	ALARM_HIGH_PC	F32	RW (Admin) RO (User)	Upper limit of the signal gas %
40111(DEC) 9CAF(HEX)	ALARM_01_MA	F32	RW (Admin) RO (User)	NAMUR mA level for alarm 01
40113(DEC) 9CB1(HEX)	ALARM_02_MA	F32	RW (Admin) RO (User)	NAMUR mA level for alarm 02

ADDRESS	NAME	TYPE	ACCESS	COMMENT
40115(DEC) 9CB3(HEX)	ALARM_03_MA	F32	RW (Admin) RO (User)	NAMUR mA level for alarm 03
40117(DEC) 9CB5(HEX)	ALARM_04_MA	F32	RW (Admin) RO (User)	NAMUR mA level for alarm 04
40119(DEC) 9CB7(HEX)	ALARM_05_MA	F32	RW (Admin) RO (User)	NAMUR mA level for alarm 05
40121(DEC) 9CB9(HEX)	ALARM_06_MA	F32	RW (Admin) RO (User)	NAMUR mA level for alarm 06
40123(DEC) 9CBB(HEX)	ALARM_07_MA	F32	RW (Admin) RO (User)	NAMUR mA level for alarm 07
40125(DEC) 9CBD(HEX)	ALARM_08_MA	F32	RW (Admin) RO (User)	NAMUR mA level for alarm 08
40127(DEC) 9CBF(HEX)	ALARM_09_MA	F32	RW (Admin) RO (User)	NAMUR mA level for alarm 09
40129(DEC) 9CC1(HEX)	ALARM_10_MA	F32	RW (Admin) RO (User)	NAMUR mA level for alarm 10
40131(DEC) 9CC3(HEX)	ALARM_11_MA	F32	RW (Admin) RO (User)	NAMUR mA level for alarm 11
40133(DEC) 9CC5(HEX)	ALARM_12_MA	F32	RW (Admin) RO (User)	NAMUR mA level for alarm 12
40135(DEC) 9CC7(HEX)	ALARM_13_MA	F32	RW (Admin) RO (User)	NAMUR mA level for alarm 13
40137(DEC) 9CC9(HEX)	ALARM_14_MA	F32	RW (Admin) RO (User)	NAMUR mA level for alarm 14
40139(DEC) 9CCB(HEX)	ALARM_15_MA	F32	RW (Admin) RO (User)	NAMUR mA level for alarm 15
40141(DEC) 9CCD(HEX)	ALARM_16_MA	F32	RW (Admin) RO (User)	NAMUR mA level for alarm 16
40143(DEC) 9CCF(HEX)	ALARM_SAVE	U16	RW (admin) RO (User)	Save alarm configuration
40170(DEC) 9CEA(HEX)	GAS_NAME	S16	RO(User) RO(Admin)	Name of gas
40178(DEC) 9CF2(HEX)	SAVE_CONFIG	U16	RO(User) RW(Admin)	Saves all configuration changes
40179(DEC) 9CF3(HEX)	SERIAL_NO	S16	RO (User) RO (Admin)	Serial number
40197(DEC) 9CfB(HEX)	PART_NO	S16	RO (User) RO (Admin)	Part number
40195(DEC) 9D03(HEX)	FIRMWARE_VERSION	F32	RO (User) RO (Admin)	Application software version
40197(DEC) 9D05(HEX)	SAFETY_FW_VERSION	F32	RO (User) RO (Admin)	Safety critical software version

ADDRESS	NAME	TYPE	ACCESS	COMMENT
40199(DEC) 9D07(HEX)	BOOTLOADER_VERSION	F32	RO (User) RO (Admin)	Bootloader software version
40201(DEC) 9D09(HEX)	USER_ID	U16	RW (User) RW (Admin)	User profile
40202(DEC) 9D0A(HEX)	PWD_LOGIN	U64	WO (User) WO (Admin)	Password entry for login
40206(DEC) 9D0E(HEX)	PWD_CHANGE	U64	WO (User) WO (Admin)	Change password for logged-in profile
40210(DEC) 9D12(HEX)	PWD_RESET	U16	RO (User) RW (Admin)	Admin can reset any user profile password
40211(DEC) 9D13(HEX)	REBOOT	U16	RO (User) RW (Admin)	Reboot the system
40212(DEC) 9D14(HEX)	FACTORY_RESET	U16	RO (User) RW (Admin)	Restore factory or restore previous
40151(DEC) 9CD7(HEX)	ALARM_SAVE	U16	RW (Admin) RO (User)	Save alarm configuration
40153(DEC) 9CD9(HEX)	SOLENOIDS	U16	RW (Admin) RO (User)	Remote operation of the calibration relays

[no content intended for this page]

Appendix B. SIL Modbus Map

ADDRESS	NAME	TYPE	ACCESS	COMMENT
40144(DEC) 9CD0(HEX)	PROOF_TEST	U16	RW (SIL) RO (Admin) RO (User)	Perform a proof test
40145(DEC) 9CD1(HEX)	TEST_SOLENOIDS	U16	RW (SIL) RO (Admin) RO (User)	Remote operation of the calibration relays
40154(DEC) 9CD2(HEX)	TEST_RELAYS	U16	RW (SIL) RO (Admin) RO (User)	Test alarm relays
40147(DEC) 9CD3(HEX)	TEST_NAMUR	U16	RW (SIL) RO (Admin) RO (User)	Test analog NAMUR levels
40148(DEC) 9CD4(HEX)	TEST_ALARMS	U16	RW (SIL) RO (Admin) RO (User)	Test a specified alarm
40149(DEC) 9CD5(HEX)	TEST_MV	U16	RW (SIL) RO (Admin) RO (User)	Simulates input mVs
40150(DEC) 9CD6(HEX)	TEST_CH1	F32	RW (SIL) RO (Admin) RO (User)	Test analog output 1
40152(DEC) 9CD8(HEX)	TEST_CH2	F32	RW (SIL) RO (Admin) RO (User)	Test analog output 2
40154(DEC) 9CDA(HEX)	TEST_O2MV	F32	RW (SIL) RO (Admin) RO (User)	Inject a simulated GasMV reading
40156(DEC) 9CDC(HEX)	TEST_BKMV	F32	RW (SIL) RO (Admin) RO (User)	Inject a simulated BKMV reading
40160(DEC) 9CE0(HEX)	TOLERANCE	F3	RW (SIL) RO (Admin) RO (User)	

[no content intended for this page]

Appendix C. Error Codes

S.No	Code	Error/Warning	Faults
1	112	ERR: NMI Fault	
2	211	ERR: MEM Fault	
3	113	ERR: BUS Fault	
4	122	ERR: USAGE FAULT	
5	131	ERR: SVC Fault	
6	212	ERR: DBGMON Fault	
7	221	ERR: OS Fault	
8	311	ERR: No Init	
9	114	ERR: SIF Timeout	
10	123	ERR: No Watchdog	ALARM_WDG_ERROR
11	132	ERR: SIF Lost	ALARM_MCU_FAULT, ALARM_DATA_FAULT
12	141	ERR: No Temp. Control	ALARM_HEAT_FAULT, ALARM_WDG_ERROR
13	213	ERR: No Comp	ALARM_SYS_ERROR, ALARM_GAS_UNDER, ALARM_GAS_OVER, ALARM_WDG_ERROR
14	222	ERR: No BK Comp	
15	231	ERR: No PR Comp	
16	312	ERR: No PRBK Comp	
17	321	ERR: No Fast Response	ALARM_SYS_ERROR, ALARM_GAS_UNDER, ALARM_GAS_OVER
18	411	ERR: No Drift Comp	ALARM_CAL_ERROR,
19	115	ERR: No Trim CH1	ALARM_CAL_ERROR
20	124	ERR: No Trim CH2	
21	133	ERR: No H2G	ALARM_SYS_ERROR
22	142	ERR: Brownout	ALARM_BROWNOUT
23	232	ERR: UART Lost	
24	241	ERR: RAM Lost	
25	313	ERR: ROM Lost	
26	322	ERR: MPU Lost	
27	331	ERR: DAC Lost	ALARM_DAC_FAULT
28	412	ERR: ADC Lost	ALARM_ADC_FAULT
29	421	ERR: PWM Lost	
30	511	ERR: Flash Lost	
31	116	ERR: IOX Lost	
32	125	ERR: LCD Lost	
33	134	ERR: ECC Error	

S.No	Code	Error/Warning	Faults
34	143	ERR: ADC CRC Error	
35	332	ERR: Not Found	
36	341	ERR: Invalid Argument	
37	413	ERR: CRC Error	
38	422	ERR: Access Denied	
39	431	ERR: Type Mismatch	
40	512	ERR: Under Range	
41	521	ERR: Over Range	
42	611	ERR: Out of Memory	
43	117	ERR: Incomplete	
44	126	ERR: No Connection	
45	234	WRN: Not yet Saved	
46	243	WRN: Warmup	
47	333	WRN: Cal Reminder	
48	414	ERR: Password Generation	
49	343	WRN: Offline	
50	146	WRN: No Clock	
51	245	ERR: Busy	
52	237	ERR: LCD Main Menu Cursor	
53	246	ERR: LCD Cursor Generation	
54	149	WRN: CRC Error	
55	158	WRN: No Modbus	
56	167	WRN: Modbus No Register	
57	176	WRN: Modbus No Command	
58	185	WRN: Modbus Idle	
59	194	WRN: Modbus Type Error	

Appendix D. Troubleshooting

Code	Error/Warning	Possible cause	Possible solution
112	NMI_FAULT	MCU has hard faulted	Reboot system via power cycle
113	BUS_FAULT	MCU has hard faulted	Reboot system via power cycle
114	SIF_TIMEOUT	Safety function did not respond in the required time	Reboot system via power cycle
115	NO_TRIM_CH1	No valid trim data available	Perform a test & trim
116	IOX_LOST	Hardware fault	Contact factory
117	TEMPMV_UNDER_RANGE	Heater has not reached temperature	Should only be active during power up, if not contact factory
118	NOT_FOUND	Missing data	Contact factory
121	HARD_FAULT	MCU has hard faulted	Reboot system via power cycle
122	USAGE_FAULT	MCU has hard faulted	Reboot system via power cycle
123	NO_WDG	Safety function did not respond in the required time	Reboot system via power cycle
124	NO_TRIM_CH2	No valid trim data available	Perform a test & trim
125	LCD_LOST	Hardware fault	Contact factory
126	TEMPMV_OVER_RANGE	Heater is over the target temperature	Verify ambient temp. is within limits
127	INVALID_ARG	Configuration is invalid	Contact factory
131	SVC_FAULT	MCU has hard faulted	Reboot system via power cycle
132	SIF_LOST	Safety function did not respond in the required time	Reboot system via power cycle
133	NO_H2G	H2G configuration is invalid	Contact factory
134	ECC_ERROR	Data corrupted	Contact factory
135	BOARDMV_UNDER_RANGE	Heater has not reached temperature	Should only be active during power up, if not contact factory
136	CRC_ERROR	Data corrupted	Contact factory
141	NO_TEMP_CONTROL	Heater has not reached temperature	Contact factory
142	BROWNOUT	Power supply not providing enough power	Verify power supply meets requirements
143	ADC_CRC_ERROR	ADC readout is corrupted	Contact factory
144	BOARDMV_OVER_RANGE	Ambient Temperature too high	Verify ambient temp. is within limits
145	ACCESS_DENIED	Attempt to configure without first logging in	Log in
146	NO_CLOCK	Time date not set	Set time and date
149	CRC_ERROR	Data corrupted - Not safety related	Repeat action or Contact factory
151	PRESSURE	Pressure sensor not calibrated	Contact factory
152	ALARM_LOST	Error occurred while raising an alarm	Contact factory
153	TEMPC_UNDER_RANGE	Heater has not reached temperature	Should only be active during power up, if not contact factory
154	TYPE_MISMATCH	Invalid configuration	Contact factory
155	PIN_RESET	System has rebooted	Should only be active during power up, if not contact factory
158	NO_MODBUS	Modbus connection cannot be established	Contact factory

Code	Error/Warning	Possible cause	Possible solution
162	TEMPC_OVER_RANGE	Heater has not reached temperature	Verify ambient temp. is within limits
163	UNDER_RANGE	Attempt to write configuration to an invalid value	Repeat action
164	SW_RESET	System has rebooted	Should only be active during power up, if not contact factory
167	MODBUS_NOREG	Attempted to read non-existing modbus register	Try different parameters
171	BRDC_UNDER_RANGE	Heater has not reached temperature	Should only be active during power up, if not contact factory
172	OVER_RANGE	Attempt to write configuration to an invalid value	Repeat action
173	LPWR_RESET	System has rebooted	Should only be active during power up, if not contact factory
176	MODBUS_NOCMD	Modbus request cannot be satisfied	Try different parameters
182	CPU_RESET1	System has rebooted	Should only be active during power up, if not contact factory
185	MODBUS_IDLE	Modbus timed out due to no activity	Try different parameters
191	CPU_RESET2	System has rebooted	Should only be active during power up, if not contact factory
194	MODBUS_TYPE_ERR	Modbus request cannot be satisfied	Try different parameters
211	MEM_FAULT	MCU has hard faulted	Reboot system via power cycle
212	DBGMON_FAULT	MCU has hard faulted	Reboot system via power cycle
213	NO_COMP	Configuration is invalid or the sensor is damaged	Contact factory
216	BRDC_OVER_RANGE	Heater has not reached temperature	Contact factory
217	INCOMPLETE	Configuration is invalid	Contact factory
221	OS_FAULT	MCU has hard faulted	Reboot system via power cycle
222	NO_BKCOMP	Configuration is invalid or the sensor is damaged	Contact factory
223	MCU_LOST	MCU has hard faulted	Contact factory
225	PRESS_UNDER_RANGE	Pressure too low	Contact factory
231	NO_PRCOMP	Configuration is invalid or the sensor is damaged	Contact factory
232	UART_LOST	Modbus connection cannot be established	Contact factory
234	PRESS_OVER_RANGE	Pressure too high	Contact factory
241	RAM_LOST	Hardware fault	Contact factory
243	TIMEOUT	Required action has not completed within required time frame	Repeat action
245	BUSY	Busy processing earlier requests	Repeat action
261	NOCOMP_BAD_GAS_CAL	Configuration is invalid or the sensor is damaged	Contact factory
311	NO_INIT	Configuration is invalid	Contact factory
312	NO_PRBKCOMP	Configuration is invalid or the sensor is damaged	Contact factory
313	ROM_LOST	Hardware fault	Contact factory
315	NOT_YET_SAVED	Configuration is invalid	Contact factory

Code	Error/Warning	Possible cause	Possible solution
321	NO_FASTRESP	Configuration is invalid or the sensor is damaged	Contact factory
322	MPU_LOST	Hardware fault	Contact factory
324	WARMUP	Heater has not reached temperature	Should only be active during power up, if not contact factory
331	DAC_LOST	Hardware fault	Try placing a load on the CHI output
332	GASMV_UNDER_RANGE	Gas provided is outside of calibrated range	1. Verify Process 2. Contact factory if process is correct
333	CAL_REMINDER	Calibration is due	Perform field calibration
341	GASMV_OVER_RANGE	Gas provided is outside of calibrated range	1. Verify Process 2. Contact factory if process is correct
343	OFFLINE	User has logged in	Log out to resume measurements
411	NO_DRIFTCOMP	Calibration data is missing	Perform a Field calibration
412	ADC_LOST	Hardware fault	Contact factory
413	GAS_UNDER_RANGE	Gas provided is outside of calibrated range	Perform a Field calibration
421	PWM_LOST	Hardware fault	Contact factory
422	GAS_OVER_RANGE	Gas provided is outside of calibrated range	1. Verify Process 2. Contact factory if process is correct
431	BKVM_UNDER_RANGE	Gas provided is outside of calibrated range	1. Verify Process 2. Contact factory if process is correct
511	FLASH_LOST	Hardware fault	Contact factory
512	BKVM_OVER_RANGE	Gas provided is outside of calibrated range	1. Verify Process 2. Contact factory if process is correct
521	PMV_UNDER_RANGE	Pressure too high	Contact Factory
611	PMV_OVER_RANGE	Pressure too low	Contact Factory

[no content intended for this page]

Appendix E. Menu Maps

E.1 Dashboard & Main Menu

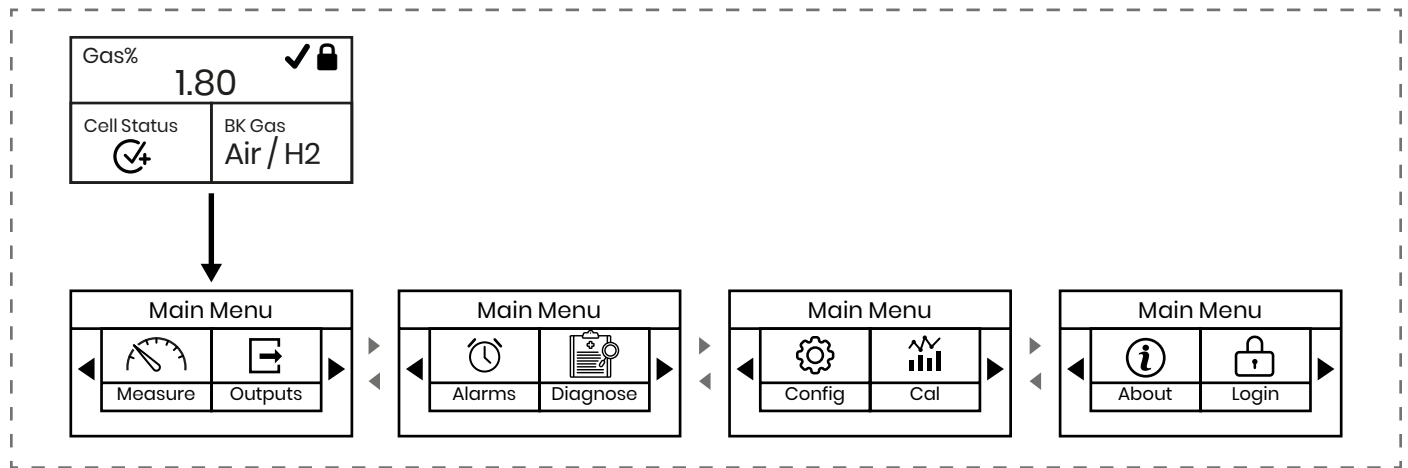

E.2 Measure Menu

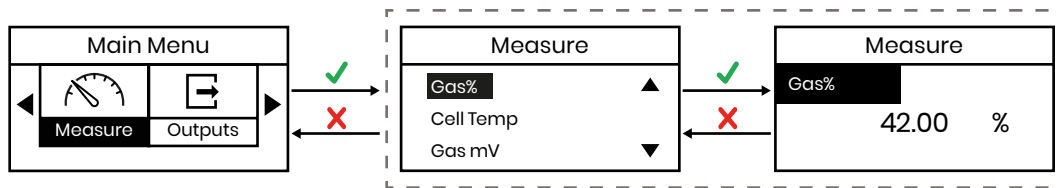

E.3 Outputs Menu

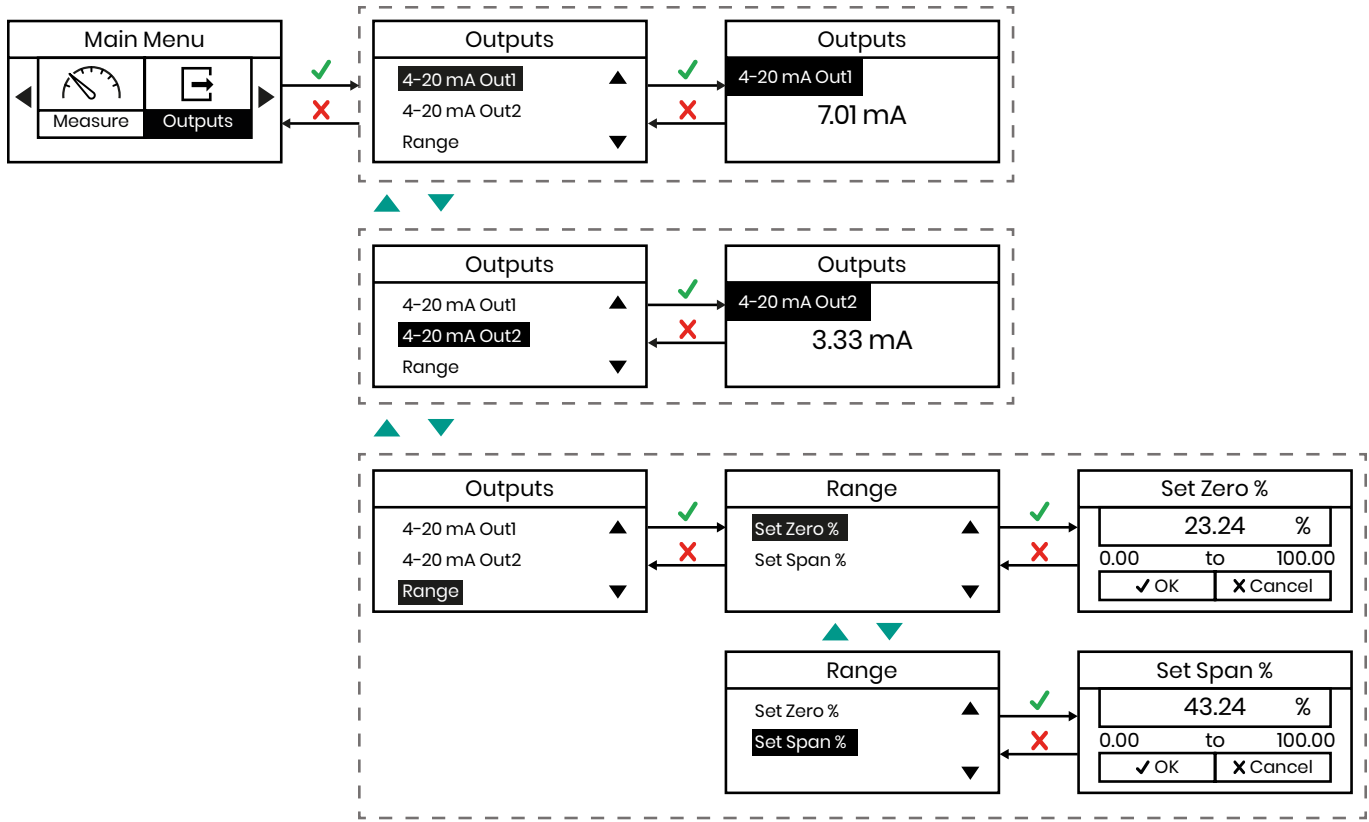

E.4 Alarms Menu

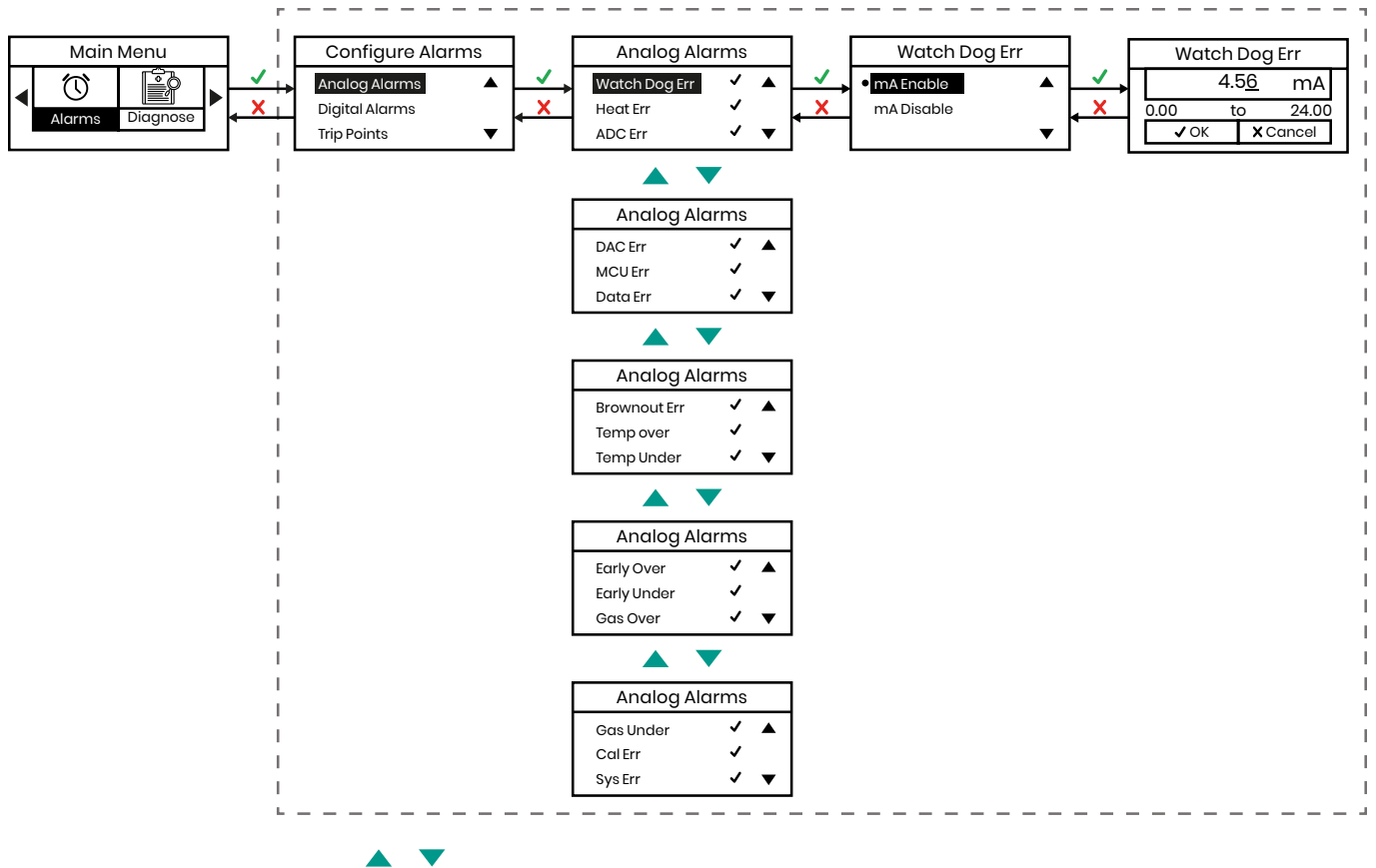

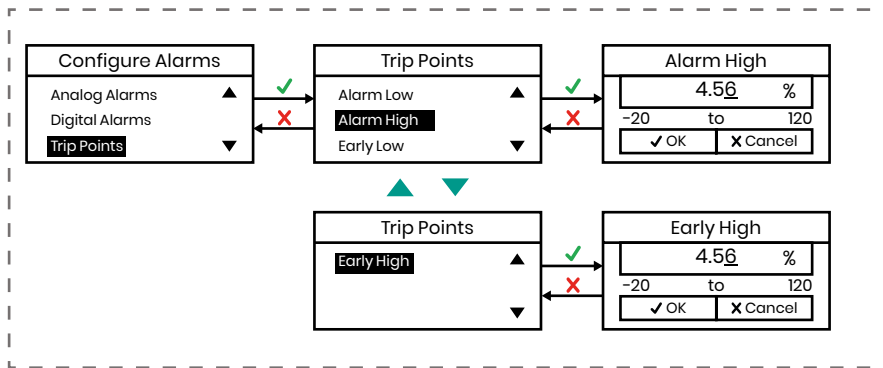
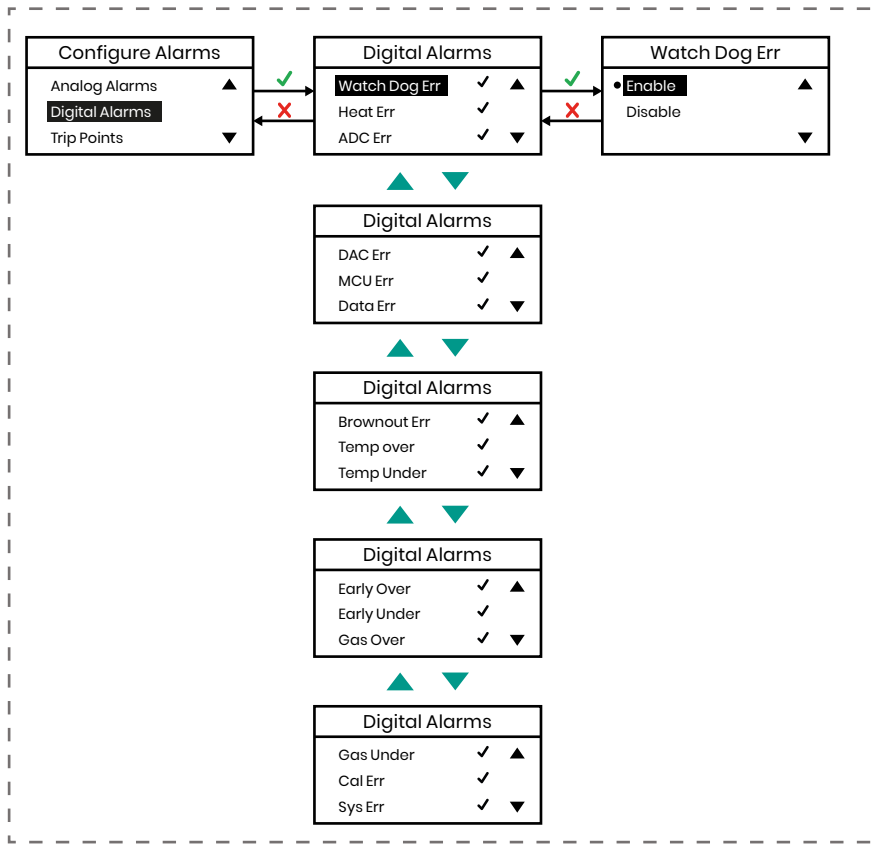

E.5 Diagnose Menu

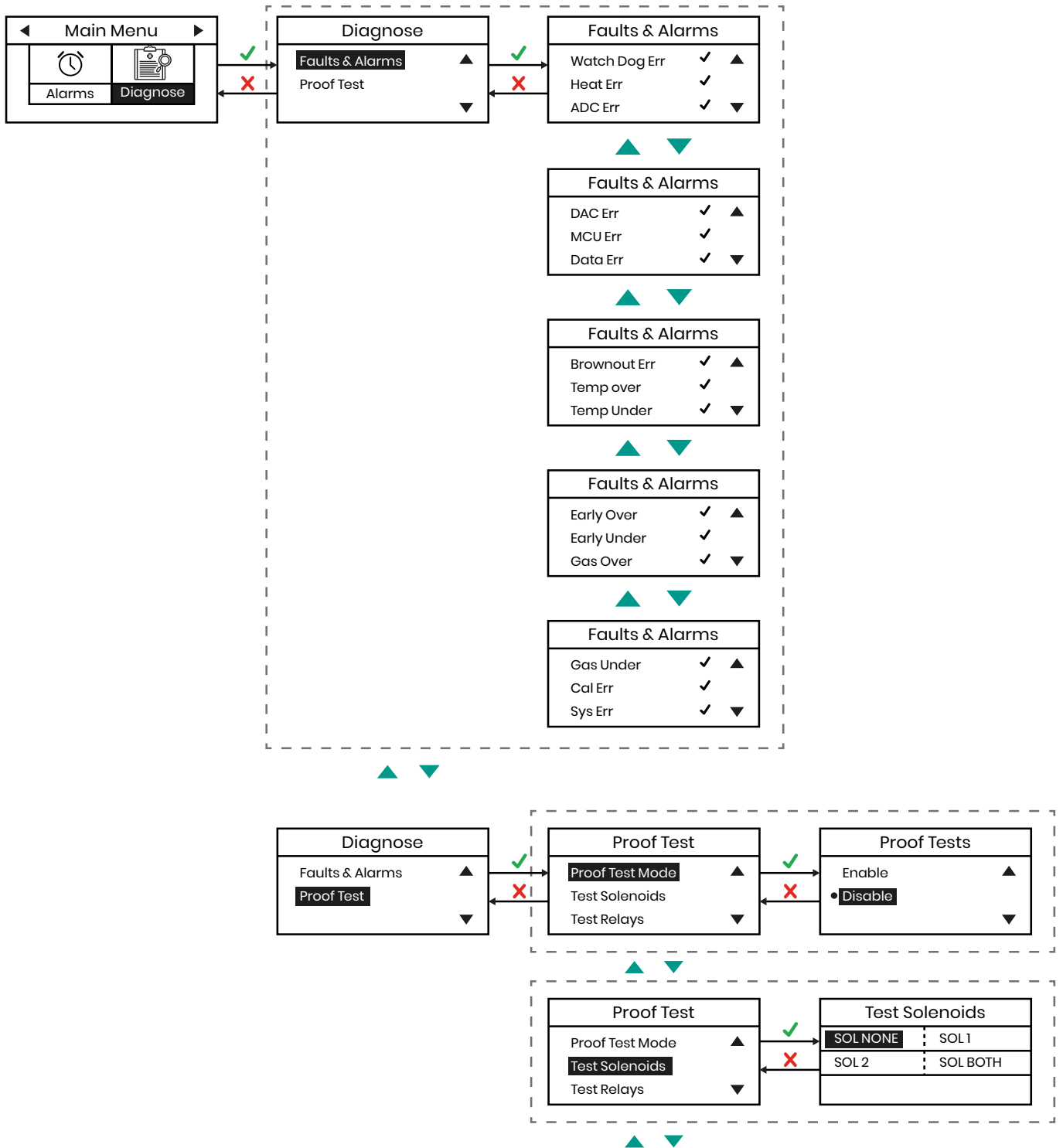

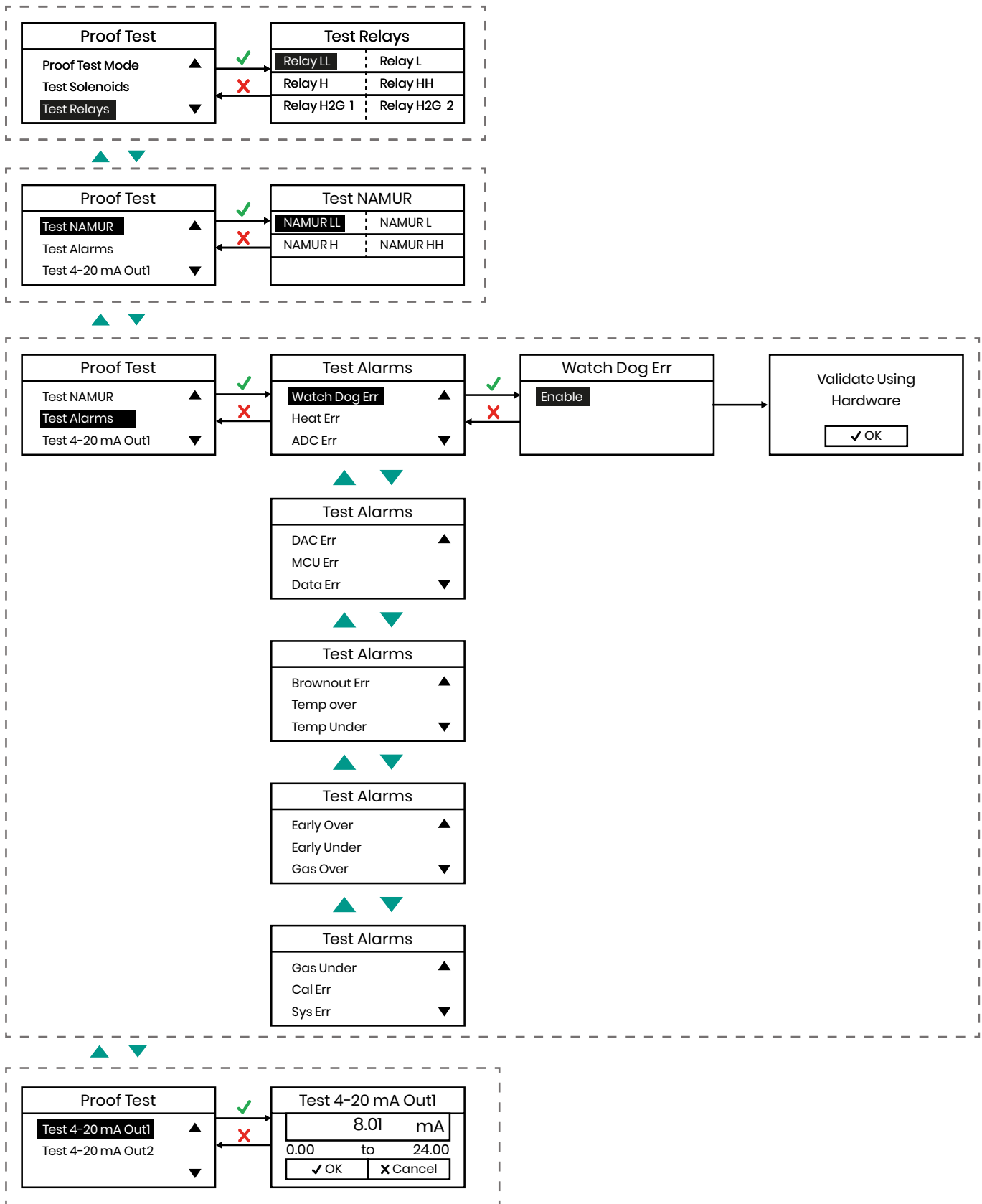

E.6 Config Menu



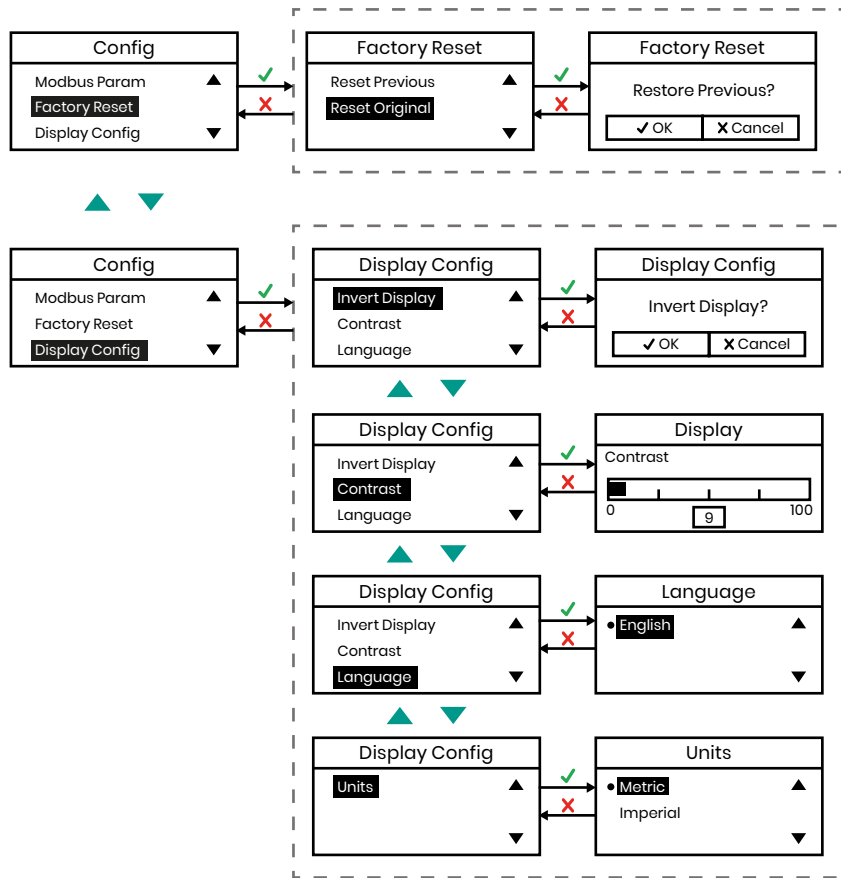

E.7 Cal Menu

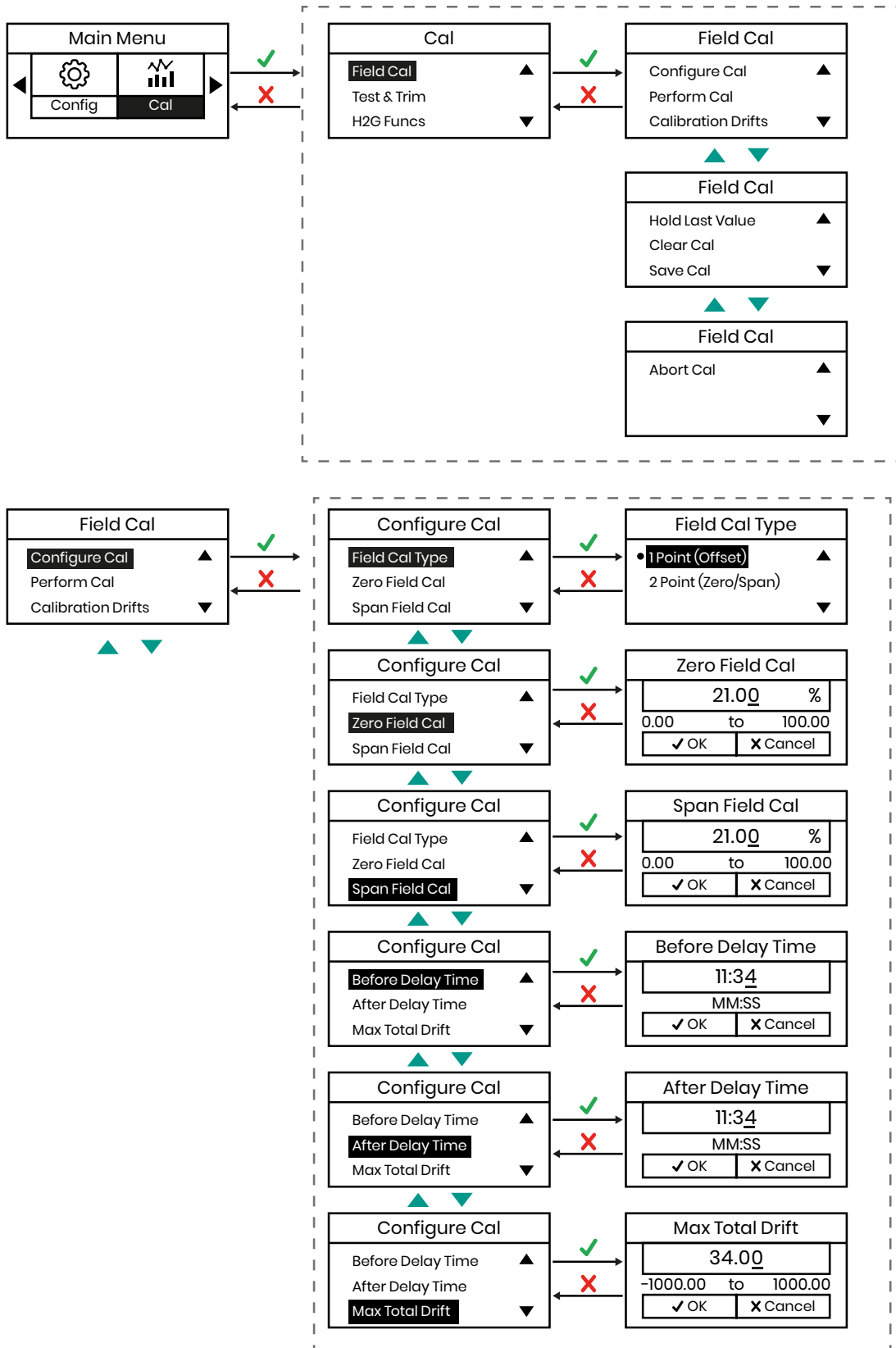

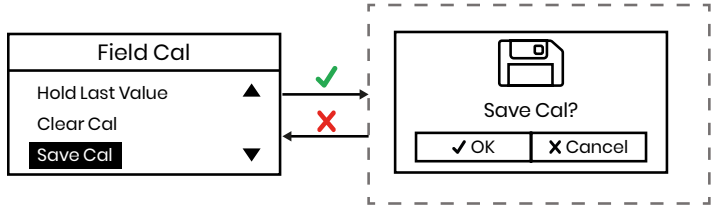
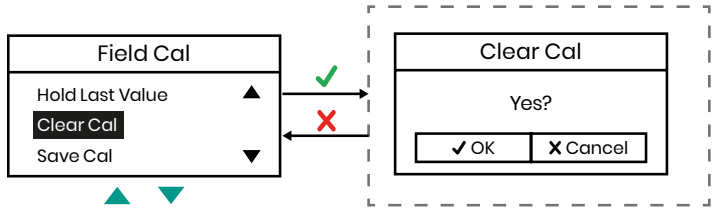
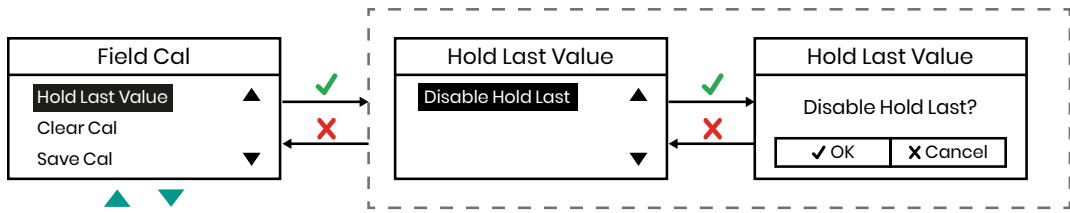
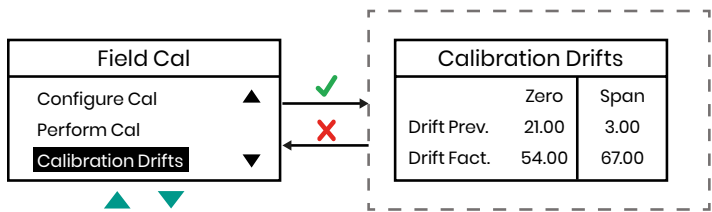
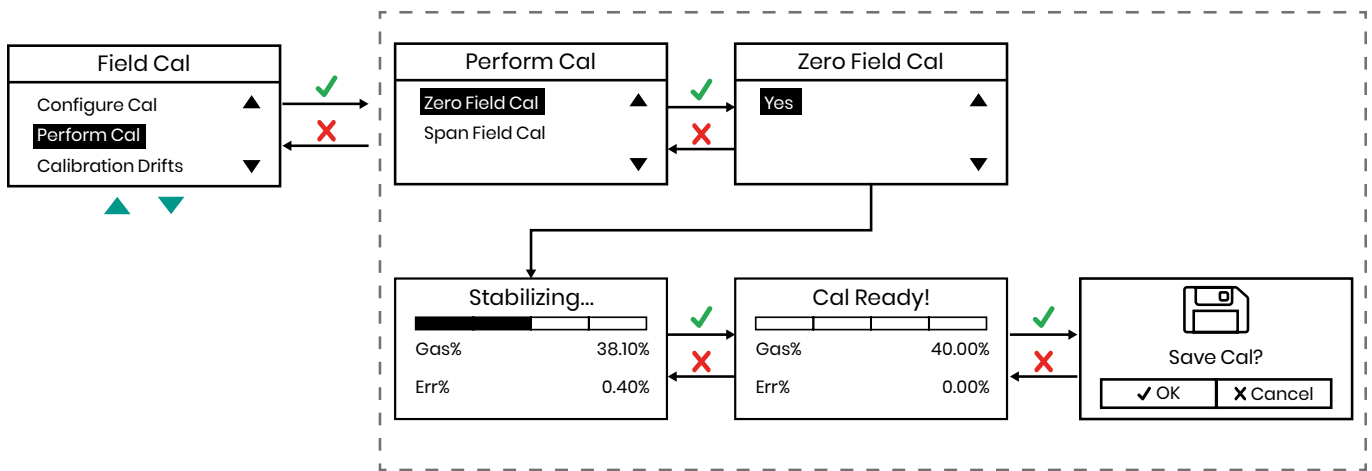

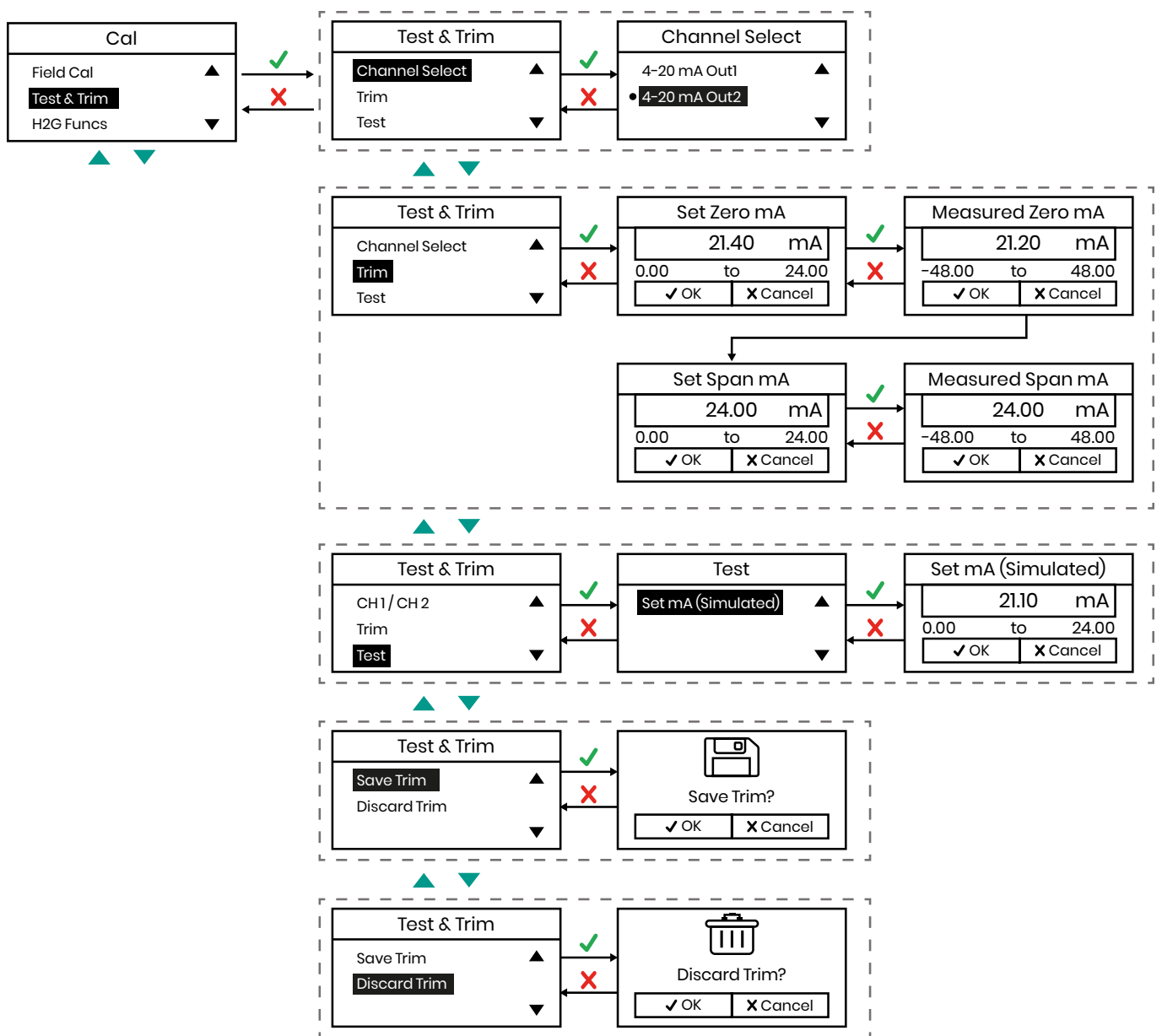

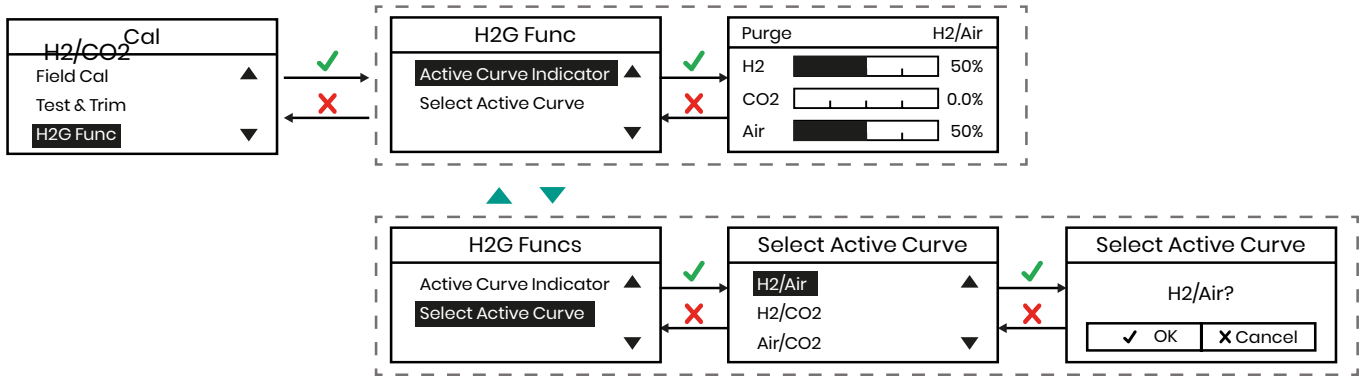

E.8 About Menu

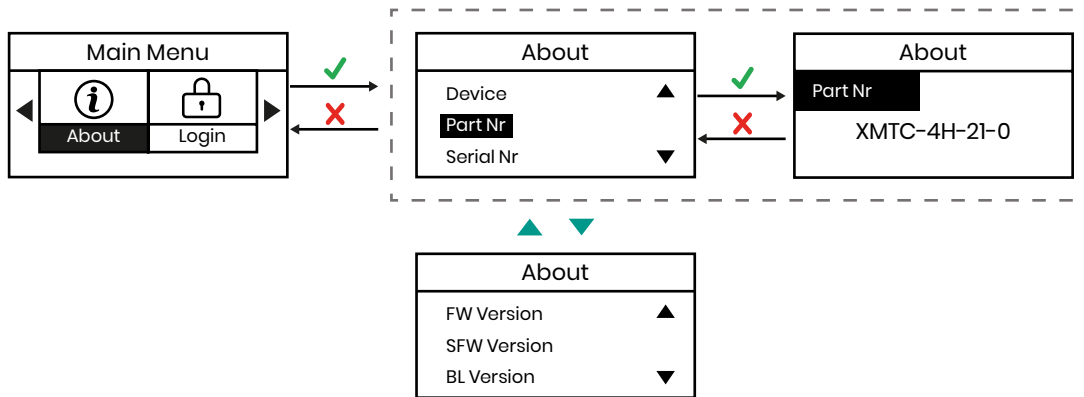

E.9 Login Menu

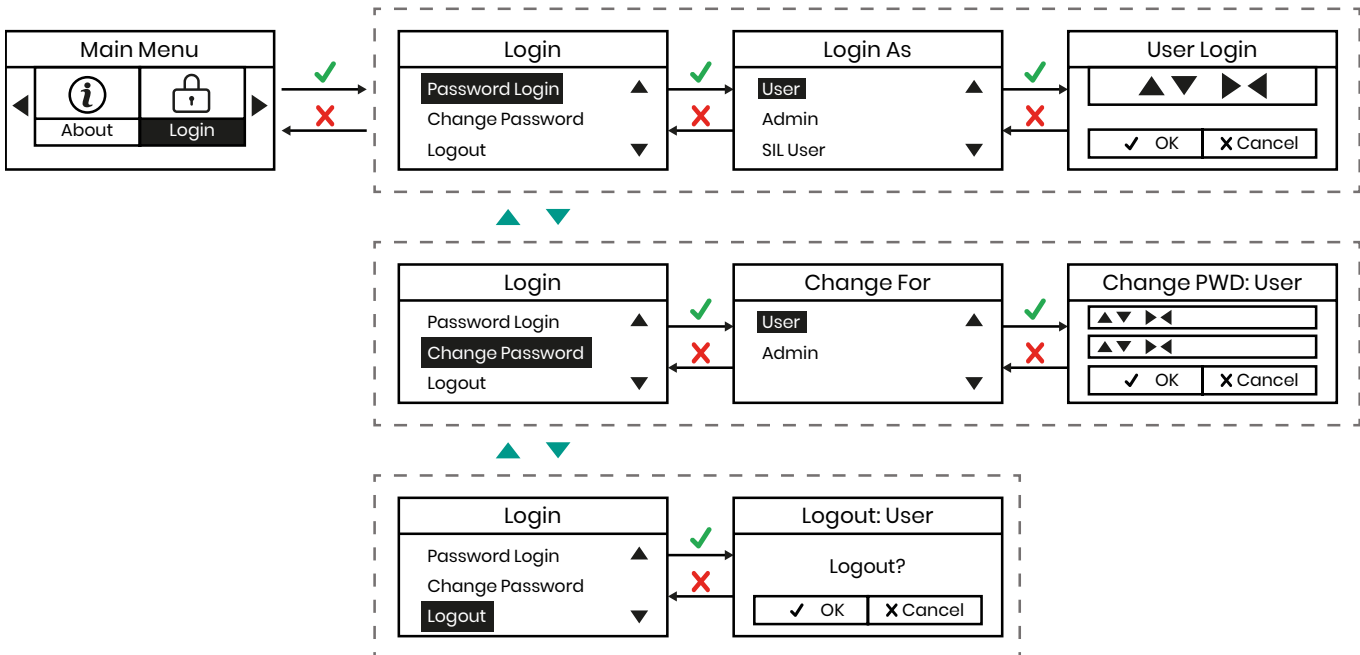

Appendix F. Bootloader

F.1 Setup

1. Power Supply
2. RS485 cable with USB adapter
3. Windows PC
4. TeraTerm Software (open-source terminal emulator)

F.2 Software Setup

1. Ensure the drivers for your RS485 to USB adapter are installed
2. Start Tera Term application
3. The new connection menu will open:
 - a. Select "Serial"
 - b. Select the USB to RS485 adapter from the drop-down menu

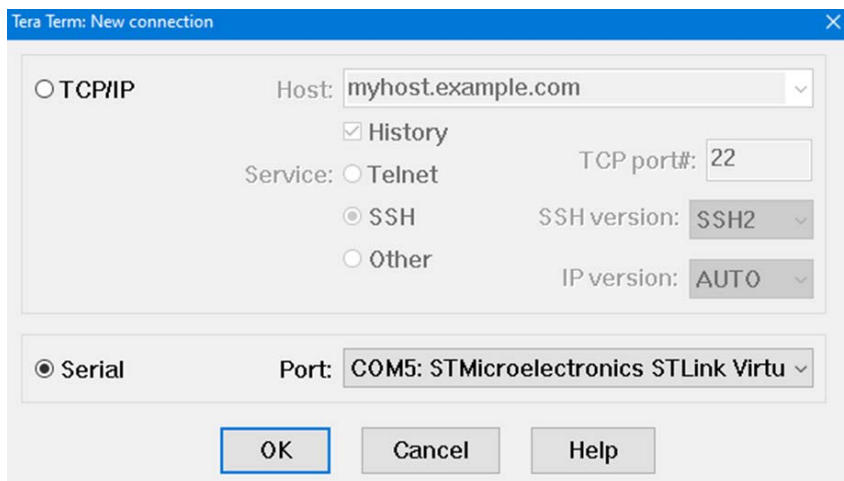

4. Set the correct settings for the serial terminal
 - a. From the menu at the top of the window, select "Setup" -> "Serial Port"
 - b. Set the settings as shown below:
 - i. Port: This does not need to be changed
 - ii. Baud Rate: 11520
 - iii. Data Bit: 8 bit
 - iv. Parity: None
 - v. Stop: 1 bit
 - vi. Flow Control: None
 - vii. Transmit Delay: 0.0
 - c. Click "OK"
5. Set the correct font and text size (optional for readability)

- a. From the menu at the top of the window, select "Setup" -> "Font"
- b. Set the font to Arial
- c. Set the font style to "Regular"

Note: These are recommended settings, you may choose whichever font you are comfortable with.

- d. Click OK

F.3 Accessing the Bootloader

When the device is powered up, the XMTCpro starts to Autoboot the application skipping the bootloader. To disable autoboot and enter the bootloader, press any key.

F.4 Firmware Upgrade

To activate the bootloader, we can skip the autoboot procedure and access the bootloader.

1. On power up, you should see the autoboot screen
2. Press any key to skip autoboot
3. A login screen will appear. You need to login to activate the bootloader.
4. Enter the password and press Enter on the HMI
5. You will be presented with 4 options. Select "Upgrade"
6. Now, using Tera Term, select "File" -> "Transfer" -> "YModem" > "Send"
7. A file browse window will open
8. File your firmware binary file and select it
9. Click "Open"
10. A pop-up window shown below will open

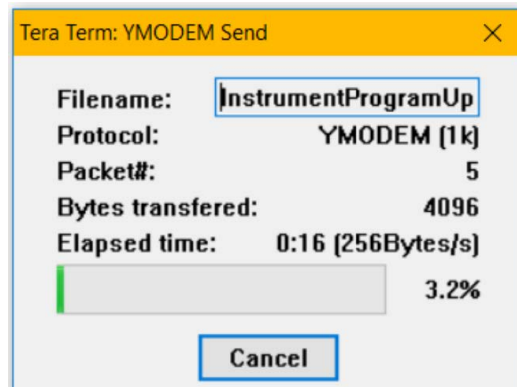

11. Wait for the firmware binary file to be downloaded (This may take a few minutes)
12. Once the file has been downloaded the bootloader will attempt to verify the downloaded binary:
13. The device will confirm the firmware has been installed correctly

IMPORTANT: It is important that the device does not lose power from this point until the firmware installation is confirmed. If the device loses power during the installation procedure it may cause a permanent software failure of the device.

F.5 Bootloader Config Menu

The config menu of the bootloader lets you setup display and serial port configurations. The display option. Gives you the following options:

1. Contrast
2. Backlight
3. Invert

The Serial menu gives you the following options for the serial port:

1. Mode
2. Baud Raute
3. Num Bits
4. Parity
5. Stop Bits

F.6 Bootloader Test Mode Menu

The Test Mode menu lets you toggle tests for the following:

1. Alarm Relays
2. Cal Relays
3. Loop 1 Relay

[no content intended for this page]

Appendix G. CE Mark Compliance



WARNING! To meet CE Mark requirements, you must shield and ground all electrical cables as described in this section (see *Table 4* below).



WARNING! CE Mark compliance is required for all units installed in EU countries.



WARNING! Cable entries of an approved flameproof design are required. These must be installed according to the manufacturer's instructions the choice of cable entry device may limit the overall installation category achieved.



WARNING! It is the responsibility of the user to ensure that all cable entry devices and covers are properly installed and secure prior to applying power to the XMTCpro.

Table 4: Wiring requirements for CE Mark compliance

Connection	Termination Modification
Power, Analog Outputs and Relay Outputs	<ol style="list-style-type: none"> 1. When connecting the line power, analog outputs, and relay output cables, select the cable entry closest to the terminal blocks as shown in the wiring diagram in <i>Section 2.4.3</i> 2. Use shielded cable*. 3. Terminate the shield to the cable gland.
RS232/RS485 Output	<ol style="list-style-type: none"> 1. Use shielded cable* to interconnect the XMTCpro enclosure with any external I/O devices. 2. Terminate the shield to the cable gland.

*Wires enclosed in a properly grounded metal conduit do not require additional shielding.

[no content intended for this page]

Appendix H. H2G Applications

The XMTCpro can be used to measure the purity of hydrogen (H₂) in hydrogen-cooled generators which are widely used in the electricity generation industry.

H.1 Problem

H₂ is used as a cooling medium in electricity generators because of its high thermal conductivity. If air leaks into the H₂, the mixture can become explosive.

H.2 Equipment

A typical instrumentation package includes an explosion-proof XMTCpro analyzer with a 4–20 mA range of 80 to 100% H₂ mounted in a sample system.

The sample system consists of inlet needle valves for sample, zero, and span; an explosion-proof XMTCpro; two pressure gauges; and two flowmeters. All components are mounted on a painted steel plate. A pump may be needed to draw a sample through the sample system. A Panametrics moisture analyzer can be used when the H₂ measurement is to be made in conjunction with a moisture measurement.

H.3 Basic Operating Procedure

The H₂ purity is continuously monitored at the generator. A sample gas flow of 0.5 SCFH (250 cc/min) is established. The sample system should be located in an area cooler than 50°C (122°F), and the tubing leading to the sample system should be at least 5 ft (1.5 m) long to insure proper cooling of the sample gas. For this application the required calibration gases are as follows:

- Zero gas - 80.0% H₂ in N₂
- Span gas - H₂ (minimum 99.95% purity)

The H2G (Hydrogen Cooled Generator) software feature is used when preparing the generator in servicing. The H₂ is displaced (purged) with CO₂ which is in turn displaced by air so that service personnel may access the interior of the generator safely.

Note: *It is essential that the purge function is only performed by competent employees.*

Note: *The purge operation poses risks of explosion (missing oxygen with hydrogen) and asphyxiation (exposing humans to noxious atmospheres).*

Note: *A secondary independent measurement is required during the purging operation.*

H.4 How Previously Handled

The system (generator) was leak checked periodically. If a leak occurred between checks, an explosion could occur. Moisture analyzers were also used for continuous analysis, since the presence of moisture in the H₂ is indirect evidence of an air leak.

H.5 Permanent Installation

Continuous monitoring of the generator H₂ purity using the XMTCpro provides increased safety. A low H₂ reading alerts plant personnel to a potential safety problem and allows them to locate the leak and correct the problem.

H.6 Specifications

Range:	80 to 100% H ₂ in N ₂
Operating Conditions:	Pressure: 0.5 to 75 psig Temperature: +30° to +50°C (+86° to +122°F)

H.7 Detailed Operating Procedure

The following procedure details the start-up, operation, and calibration of the XMTcpro sample system for the hydrogen purity applications. Refer to *Figure 15* below for identification of valves. Needle valves N1 through N3 on the sample system drawing have the following functions:

- N1 – controls the flow of the process sample gas
- N2 – controls the flow of the zero calibration gas
- N3 – controls the flow of the span calibration gas
- N4 & N5 – 3 way valve to divert gas flow for calibration

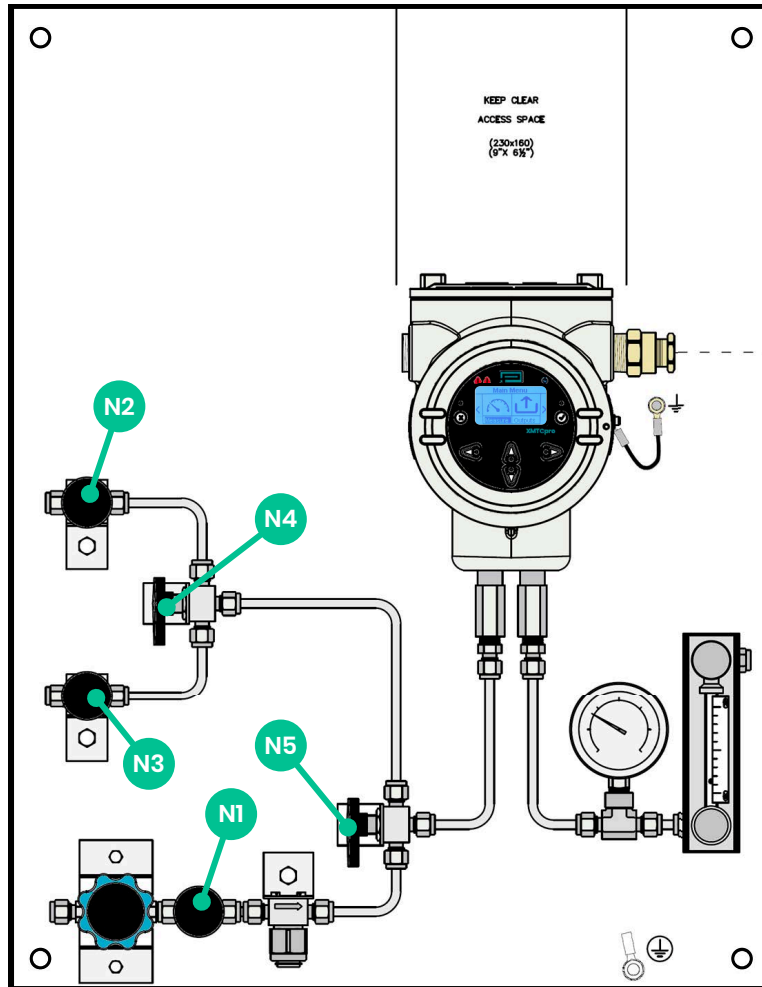

Figure 15: XMTcpro Sample System H2G Valves



WARNING! The user is required to check the gas in the chamber prior to entry. This check must be independent of the software in the XMTcpro.



WARNING! Switching to the H₂/CO₂ curve is not allowed until a 100% CO₂ measurement is taken independent of the XMTcpro indication prior to the introduction of air.

H.7.1 Start Up

1. Mount the sample system in an enclosed area heated to a temperature above 0°C.
2. Make sure that all needle valves are fully closed.
3. Run 1/4" tubing from the process to N1 (sample inlet).

Note: *If the process is at a high pressure, a pressure regulator should be placed before this valve.*



CAUTION! The XMTCpro is calibrated and intended for use at atmospheric pressure. Higher pressures will lead to inaccurate readings, may result in damage to the instrument, and/or may pose a safety problem.

4. Run 1/4" tubing from the pressure regulator on the cylinder containing the zero calibration gas to N2 (zero gas inlet).
5. Run 1/4" tubing from the pressure regulator on the cylinder containing the span calibration gas to the span gas inlet, N3.

Note: *No pressure restrictions should be placed on the flowmeter outlets. Any tubing on the outlets should be at least 1/4" in diameter, and preferably 1/2".*

6. Leak test all sample system fittings, as well as those leading to the sample system.
7. Bring 24 VDC to the XMTCpro. Refer to *Chapter 2, Installation*. Installation, and allow 1 hour before proceeding.
8. Slowly open N1 until the sample outlet flowmeter reads mid-scale. The pressure gauge at the sample outlet should read 0 psig.

After the system has come to equilibrium, the sample system should be checked periodically to ensure that there is gas flow through both flowmeters.

H.7.2 Calibration

Refer to *Chapter 6, Calibration with HMI* and *Chapter 7, Calibration with Modbus*, for the complete XMTCpro calibration procedure. The procedures below are only a supplement to that procedure. These procedures show the valve configurations necessary to bring the calibration gases to the XMTCpro.

Zero gas calibration:

1. Fully close N1 and set N4 and N5 to route gas from N2 to the inlet.
2. Slowly open N2 until the sample outlet flowmeter reads mid-scale. The pressure gauge at the sample outlet should read 0 psig.

Allow enough time for the tubing to be cleared of the sample gas or calibration span gas before making any adjustments to the analyzer.

Span gas calibration:

1. Fully close N2 and set N4 and N5 to route gas from N3 to the inlet.
2. Slowly open N3 until the sample outlet flowmeter reads mid-scale. The pressure gauge at the sample outlet should read 0 psig.

Returning to normal operation:

1. Fully close N3 and set N5 to route gas from N1 to the inlet.
2. Slowly open N1 until the sample outlet flowmeter reads mid-scale. The pressure gauge at the sample outlet should read 0 psig.
3. After the system has come to equilibrium, the sample system should be checked periodically to insure that there is flow through the flow meter.

[no content intended for this page]

Appendix I. Abbreviations

Abbreviation	Meaning
HMI	Human Machine Interface
LCD	Liquid-Crystal Display
Cal	Calibration
H2G	Hydrogen Cooled Generator
SIL	Safety Integrity Level
PC	Personal Computer
ERR	Error
CH1	Channel 1
CH2	Channel 2
LED	Light Emitting Diode

[no content intended for this page]

Appendix J. Relative thermal conductivity of common gases

Gas	Temperature = 0°C (32°F)	Temperature = 100°C (212°F)
Air, N ₂ /O ₂	1.000	1.000
Hydrogen, H ₂	6.968	6.803
Helium, He	5.970	5.530
Nitrogen, N ₂	1.000	0.989
Oxygen, O ₂	1.018	1.028
Neon, Ne	1.900	1.840
Argon, Ar	0.677	0.665
Chlorine, Cl ₂	0.323	0.340
Carbon Monoxide, CO	0.962	0.958
Carbon Dioxide, CO ₂	0.603	0.704
Nitric Oxide, NO	0.980	0.978
Sulfur Dioxide, SO ₂	0.350	0.381
Hydrogen Sulfide, H ₂ S	0.538	0.562
Carbon Disulfide, CS ₂	0.285	0.300
Ammonia, NH ₃	0.897	1.040
Water Vapor, H ₂ O	0.755	0.771
Methane, CH ₄	1.250	1.450
Ethane, C ₂ H ₆	0.750	0.970
Propane, C ₃ H ₈	0.615	0.832
n-Butane, C ₄ H ₁₀	0.552	0.744
isobutane, C ₄ H ₁₀	0.569	0.776
n-Pentane, C ₅ H ₁₂	0.535	0.702
isopentane, C ₅ H ₁₂	0.515	0.702
n-Hexane, C ₆ H ₁₄	0.508	0.662
n-Heptane, C ₇ H ₁₆	0.399	0.582
Cyclohexane, C ₆ H ₁₂	0.375	0.576
Ethylene, C ₂ H ₄	0.720	0.980
Propylene, C ₃ H ₆	0.626	0.879
Acetylene, C ₂ H ₂	0.770	0.900
1,3 Butadiene, C ₄ H ₆	0.441	0.642
Nitrous Oxide, N ₂ O	0.633	0.762
Ethylene Oxide, C ₂ H ₄ O	0.469	0.620
Ethyl Alcohol, C ₂ H ₅ OH	0.590	0.685
Isopropyl Alcohol*, C ₃ H ₇ OH	0.492	0.644
Acetone, C ₃ H ₆ O	0.406	0.557
Methyl Chloride, CH ₃ Cl	0.377	0.530

Gas	Temperature = 0°C (32°F)	Temperature = 100°C (212°F)
Ethyl Chloride, C ₂ H ₅ Cl	0.391	0.540
Vinyl Chloride, C ₂ H ₃ Cl	0.443	0.551
Freon-11, CCl ₃ F	0.286	0.368
Freon-12, CCl ₂ F ₂	0.344	0.442
Freon-22, CHClF ₂	0.388	0.474
Freon-113, C ₂ Cl ₃ F ₃	0.277	0.369
Hydrogen Chloride, HCl	0.520	0.517
Hydrogen Fluoride, HF	0.654	0.959

*Consult Panametrics

Appendix K. Max Drift Calibration

$$x = \frac{d}{t}$$

Where,

x = Current drift in %/week

d = Total Drift in gas% as reported by the XMTcpro

t = Time delta between factory calibration and field calibration measured in weeks obtained from the calibration data sheet

Note: *If x exceeds $\pm 0.5\%/week$ then the unit is faulty and needs to be repaired.*

[no content intended for this page]

Warranty

Each instrument manufactured by Panametrics is warranted to be free from defects in material and workmanship. Liability under this warranty is limited to restoring the instrument to normal operation or replacing the instrument, at the sole discretion of Panametrics. Fuses and batteries are specifically excluded from any liability. This warranty is effective from the date of delivery to the original purchaser. If Panametrics determines that the equipment was defective, the warranty period is:

- One year from delivery for electronic or mechanical failures.
- One year from delivery for sensor shelf life.

If Panametrics determines that the equipment was damaged by misuse, improper installation, the use of unauthorized replacement parts, or operating conditions outside the guidelines specified by Panametrics, the repairs are not covered under this warranty.

The warranties set forth herein are exclusive and are in lieu of all other warranties whether statutory, express or implied (including warranties or merchantability and fitness for a particular purpose, and warranties arising from course of dealing or usage or trade).

Return Policy

If a Panametrics instrument malfunctions within the warranty period, the following procedure must be completed:

1. Notify Panametrics, giving full details of the problem, and provide the model number and serial number of the instrument. If the nature of the problem indicates the need for factory service, Panametrics will issue a Return Material Authorization (RMA), and shipping instructions for the return of the instrument to a service center will be provided.
2. If Panametrics instructs you to send your instrument to a service center, it must be shipped prepaid to the authorized repair station indicated in the shipping instructions.
3. Upon receipt, Panametrics will evaluate the instrument to determine the cause of the malfunction.

Then, one of the following courses of action will then be taken:

- If the damage is covered under the terms of the warranty, the instrument will be repaired at no cost to the owner and returned.
- If Panametrics determines that the damage is not covered under the terms of the warranty, or if the warranty has expired, an estimate for the cost of the repairs at standard rates will be provided. Upon receipt of the owner's approval to proceed, the instrument will be repaired and returned.

[no content intended for this page]



Scan here or use the link below for
Customer Service, Technical Support,
or Service Information:
<https://panametrics.com/support>

Technical Support email:
panametricstechsupport@bakerhughes.com

Copyright 2024 Baker Hughes company.

This material contains one or more registered
trademarks of Baker Hughes Company and its
subsidiaries in one or more countries. All third-party
product and company names are trademarks of their
respective holders.

BH078C11 EN A (12/2024)

Baker Hughes 