

Introduction

Kintex®-7 FPGAs are available in -3, -2, -1, -1L, and -2L speed grades, with -3 having the highest performance. The -2L devices are screened for lower maximum static power and can operate at lower core voltages for lower dynamic power than the -2 devices. The -2L industrial (I) temperature devices operate only at $V_{CCINT} = 0.95V$. The -2L extended (E) temperature devices can operate at either $V_{CCINT} = 0.9V$ or $1.0V$. The -2LE devices when operated at $V_{CCINT} = 1.0V$, and the -2LI devices when operated at $V_{CCINT} = 0.95V$, have the same speed specifications as the -2 speed grade, except where noted. When the -2LE devices are operated at $V_{CCINT} = 0.9V$, the speed specifications, static power, and dynamic power are reduced. The -1L military (M) temperature devices have the same speed specifications as the -1 military temperature devices and are screened for lower maximum static power.

Kintex-7 FPGA DC and AC characteristics are specified in commercial, extended, industrial, expanded (-1Q), and military (-1M) temperature ranges. Except for the operating temperature range or unless otherwise noted, all the DC and AC electrical parameters are the same for a particular

speed grade (that is, the timing characteristics of a -1 speed grade military temperature device are the same as for a -1 speed grade commercial temperature device). However, only selected speed grades and/or devices are available in each temperature range. For example, -1M is only available in the defense-grade Kintex-7Q family, and -1Q is only available in XA Kintex-7 FPGAs.

All supply voltage and junction temperature specifications are representative of worst-case conditions. The parameters included are common to popular designs and typical applications.

Available device and package combinations can be found in:

- *7 Series FPGAs Overview* ([DS180](#))
- *Defense-Grade 7 Series FPGAs Overview* ([DS185](#))
- *XA Kintex-7 FPGA Data Sheet: Overview* ([DS175](#))

This Kintex-7 FPGA data sheet, part of an overall set of documentation on the 7 series FPGAs, is available on the Xilinx website at www.xilinx.com/documentation.

DC Characteristics

Table 1: Absolute Maximum Ratings (1)

Symbol	Description	Min	Max	Units
FPGA Logic				
V_{CCINT}	Internal supply voltage	-0.5	1.1	V
V_{CCAUX}	Auxiliary supply voltage	-0.5	2.0	V
V_{CCBRAM}	Supply voltage for the block RAM memories	-0.5	1.1	V
V_{CCO}	Output drivers supply voltage for HR I/O banks	-0.5	3.6	V
	Output drivers supply voltage for HP I/O banks	-0.5	2.0	V
V_{CCAUX_IO}	Auxiliary supply voltage	-0.5	2.06	V
V_{REF}	Input reference voltage	-0.5	2.0	V
$V_{IN}^{(2)(3)(4)}$	I/O input voltage for HR I/O banks	-0.40	$V_{CCO} + 0.55$	V
	I/O input voltage for HP I/O banks	-0.55	$V_{CCO} + 0.55$	V
	I/O input voltage (when $V_{CCO} = 3.3V$) for V_{REF} and differential I/O standards except TMD5_33 ⁽⁵⁾	-0.40	2.625	V
V_{CCBATT}	Key memory battery backup supply	-0.5	2.0	V

Table 1: Absolute Maximum Ratings ⁽¹⁾ (Cont'd)

Symbol	Description	Min	Max	Units
GTX Transceiver				
V _{MGTAVCC}	Analog supply voltage for the GTX transmitter and receiver circuits	-0.5	1.1	V
V _{MGTAVTT}	Analog supply voltage for the GTX transmitter and receiver termination circuits	-0.5	1.32	V
V _{MGTVCCAUX}	Auxiliary analog Quad PLL (QPLL) voltage supply for the GTX transceivers	-0.5	1.935	V
V _{MGTREFCLK}	GTX transceiver reference clock absolute input voltage	-0.5	1.32	V
V _{MGTAVTTRCAL}	Analog supply voltage for the resistor calibration circuit of the GTX transceiver column	-0.5	1.32	V
V _{IN}	Receiver (RXP/RXN) and Transmitter (TXP/TXN) absolute input voltage	-0.5	1.26	V
I _{DCIN-FLOAT}	DC input current for receiver input pins DC coupled RX termination = floating	-	14	mA
I _{DCIN-MGTAVTT}	DC input current for receiver input pins DC coupled RX termination = V _{MGTAVTT}	-	12	mA
I _{DCIN-GND}	DC input current for receiver input pins DC coupled RX termination = GND	-	6.5	mA
I _{DCOUT-FLOAT}	DC output current for transmitter pins DC coupled RX termination = floating	-	14	mA
I _{DCOUT-MGTAVTT}	DC output current for transmitter pins DC coupled RX termination = V _{MGTAVTT}	-	12	mA
XADC				
V _{CCADC}	XADC supply relative to GNDADC	-0.5	2.0	V
V _{REFP}	XADC reference input relative to GNDADC	-0.5	2.0	V
Temperature				
T _{STG}	Storage temperature (ambient)	-65	150	°C
T _{SOL}	Maximum soldering temperature for Pb/Sn component bodies ⁽⁶⁾	-	+220	°C
	Maximum soldering temperature for Pb-free component bodies ⁽⁶⁾	-	+260	°C
T _j	Maximum junction temperature ⁽⁶⁾	-	+125	°C

Notes:

1. Stresses beyond those listed under Absolute Maximum Ratings might cause permanent damage to the device. These are stress ratings only, and functional operation of the device at these or any other conditions beyond those listed under Operating Conditions is not implied. Exposure to Absolute Maximum Ratings conditions for extended periods of time might affect device reliability.
2. The lower absolute voltage specification always applies.
3. For I/O operation, refer to the *7 Series FPGAs SelectIO Resources User Guide* (UG471).
4. The maximum limit applies to DC signals. For maximum undershoot and overshoot AC specifications, see Table 4 and Table 5.
5. See Table 10 for TMD5_33 specifications.
6. For soldering guidelines and thermal considerations, see the *7 Series FPGA Packaging and Pinout Specification* (UG475).

Table 2: Recommended Operating Conditions ⁽¹⁾⁽²⁾

Symbol	Description	Min	Typ	Max	Units
FPGA Logic					
V _{CCINT} ⁽³⁾	For -3, -2, -2LE (1.0V), -1, -1M, -1LM, -1Q devices: internal supply voltage	0.97	1.00	1.03	V
	For -2LE (0.9V) devices: internal supply voltage	0.87	0.90	0.93	V
	For -2LI (0.95V) devices: internal supply voltage	0.93	0.95	0.97	V
V _{CCBRAM} ⁽³⁾	For -3, -2, -2LE (1.0V), -1, -1M, -1LM, -1Q devices: block RAM supply voltage	0.97	1.00	1.03	V
	For -2LE (0.9V) devices: block RAM supply voltage	0.87	0.90	1.03	V
	For -2LI (0.95V) devices: block RAM supply voltage	0.93	0.95	0.97	V
V _{CCAUX}	Auxiliary supply voltage	1.71	1.80	1.89	V
V _{CCO} ⁽⁴⁾⁽⁵⁾	Supply voltage for HR I/O banks	1.14	-	3.465	V
	Supply voltage for HP I/O banks	1.14	-	1.89	V

Table 2: Recommended Operating Conditions ⁽¹⁾⁽²⁾ (Cont'd)

Symbol	Description	Min	Typ	Max	Units
V _{CCAUX_IO} ⁽⁶⁾	Auxiliary supply voltage when set to 1.8V	1.71	1.80	1.89	V
	Auxiliary supply voltage when set to 2.0V	1.94	2.00	2.06	V
V _{IN} ⁽⁷⁾	I/O input voltage	-0.20	-	V _{CCO} + 0.2	V
	I/O input voltage (when V _{CCO} = 3.3V) for V _{REF} and differential I/O standards except TMDS_33 ⁽⁸⁾	-0.20	-	2.625	V
I _{IN} ⁽⁹⁾	Maximum current through any pin in a powered or unpowered bank when forward biasing the clamp diode.	-	-	10	mA
V _{CCBATT} ⁽¹⁰⁾	Battery voltage	1.0	-	1.89	V
GTX Transceiver					
V _{MGTAVCC} ⁽¹¹⁾	Analog supply voltage for the GTX transceiver QPLL frequency range ≤ 10.3125 GHz ⁽¹²⁾⁽¹³⁾	0.97	1.0	1.08	V
	Analog supply voltage for the GTX transceiver QPLL frequency range > 10.3125 GHz	1.02	1.05	1.08	V
V _{MGTAVTT} ⁽¹¹⁾	Analog supply voltage for the GTX transmitter and receiver termination circuits	1.17	1.2	1.23	V
V _{MGTVCCAUX} ⁽¹¹⁾	Auxiliary analog QPLL voltage supply for the transceivers	1.75	1.80	1.85	V
V _{MGTAVTRCAL} ⁽¹¹⁾	Analog supply voltage for the resistor calibration circuit of the GTX transceiver column	1.17	1.2	1.23	V
XADC					
V _{CCADC}	XADC supply relative to GNDADC	1.71	1.80	1.89	V
V _{REFP}	Externally supplied reference voltage	1.20	1.25	1.30	V
Temperature					
T _j	Junction temperature operating range for commercial (C) temperature devices	0	-	85	°C
	Junction temperature operating range for extended (E) temperature devices	0	-	100	°C
	Junction temperature operating range for industrial (I) temperature devices	-40	-	100	°C
	Junction temperature operating range for military (M) temperature devices	-55	-	125	°C
	Junction temperature operating range for expanded (Q) temperature devices	-40	-	125	°C

Notes:

- All voltages are relative to ground.
- For the design of the power distribution system, consult the *7 Series FPGAs PCB Design and Pin Planning Guide* ([UG483](#)).
- V_{CCINT} and V_{CCBRAM} should be connected to the same supply.
- Configuration data is retained even if V_{CCO} drops to 0V.
- Includes V_{CCO} of 1.2V, 1.35V, 1.5V, 1.8V, 2.5V (HR I/O only), and 3.3V (HR I/O only) at ±5%.
- For more information, refer to the V_{CCAUX_IO} section of *7 Series FPGAs SelectIO Resources User Guide* ([UG471](#)).
- The lower absolute voltage specification always applies.
- See [Table 10](#) for TMDS_33 specifications.
- A total of 200 mA per bank should not be exceeded.
- V_{CCBATT} is required only when using bitstream encryption. If battery is not used, connect V_{CCBATT} to either ground or V_{CCAUX}.
- Each voltage listed requires the filter circuit described in the *7 Series FPGAs GTX/GTH Transceivers User Guide* ([UG476](#)).
- For data rates ≤ 10.3125 Gb/s, V_{MGTAVCC} should be 1.0V ±3% for lower power consumption.
- For lower power consumption, V_{MGTAVCC} should be 1.0V ±3% over the entire CPLL frequency range.

Table 3: DC Characteristics Over Recommended Operating Conditions

Symbol	Description	Min	Typ ⁽¹⁾	Max	Units
V _{DRINT}	Data retention V _{CCINT} voltage (below which configuration data might be lost)	0.75	–	–	V
V _{DRI}	Data retention V _{CCAUX} voltage (below which configuration data might be lost)	1.5	–	–	V
I _{REF}	V _{REF} leakage current per pin	–	–	15	μA
I _L	Input or output leakage current per pin (sample-tested)	–	–	15	μA
C _{IN} ⁽²⁾	Die input capacitance at the pad	–	–	8	pF
I _{RPU}	Pad pull-up (when selected) @ V _{IN} = 0V, V _{CCO} = 3.3V	90	–	330	μA
	Pad pull-up (when selected) @ V _{IN} = 0V, V _{CCO} = 2.5V	68	–	250	μA
	Pad pull-up (when selected) @ V _{IN} = 0V, V _{CCO} = 1.8V	34	–	220	μA
	Pad pull-up (when selected) @ V _{IN} = 0V, V _{CCO} = 1.5V	23	–	150	μA
	Pad pull-up (when selected) @ V _{IN} = 0V, V _{CCO} = 1.2V	12	–	120	μA
I _{RPD}	Pad pull-down (when selected) @ V _{IN} = 3.3V	68	–	330	μA
	Pad pull-down (when selected) @ V _{IN} = 1.8V	45	–	180	μA
I _{CCADC}	Analog supply current, analog circuits in powered up state	–	–	25	mA
I _{BATT} ⁽³⁾	Battery supply current	–	–	150	nA
R _{IN_TERM} ⁽⁴⁾	Thevenin equivalent resistance of programmable input termination to V _{CCO} /2 (UNTUNED_SPLIT_40)	28	40	55	Ω
	Thevenin equivalent resistance of programmable input termination to V _{CCO} /2 (UNTUNED_SPLIT_50)	35	50	65	Ω
	Thevenin equivalent resistance of programmable input termination to V _{CCO} /2 (UNTUNED_SPLIT_60)	44	60	83	Ω
n	Temperature diode ideality factor	–	1.010	–	–
r	Temperature diode series resistance	–	2	–	Ω

Notes:

1. Typical values are specified at nominal voltage, 25°C.
2. This measurement represents the die capacitance at the pad, not including the package.
3. Maximum value specified for worst case process at 25°C.
4. Termination resistance to a V_{CCO}/2 level.

Table 4: V_{IN} Maximum Allowed AC Voltage Overshoot and Undershoot for HR I/O Banks⁽¹⁾⁽²⁾

AC Voltage Overshoot	% of UI at –55°C to 125°C	AC Voltage Undershoot	% of UI at –55°C to 125°C
V _{CCO} + 0.55	100	–0.40	100
		–0.45	61.7
		–0.50	25.8
		–0.55	11.0
V _{CCO} + 0.60	46.6	–0.60	4.77
V _{CCO} + 0.65	21.2	–0.65	2.10
V _{CCO} + 0.70	9.75	–0.70	0.94
V _{CCO} + 0.75	4.55	–0.75	0.43
V _{CCO} + 0.80	2.15	–0.80	0.20
V _{CCO} + 0.85	1.02	–0.85	0.09
V _{CCO} + 0.90	0.49	–0.90	0.04

Table 4: V_{IN} Maximum Allowed AC Voltage Overshoot and Undershoot for HR I/O Banks⁽¹⁾⁽²⁾ (Cont'd)

AC Voltage Overshoot	% of UI at -55°C to 125°C	AC Voltage Undershoot	% of UI at -55°C to 125°C
$V_{CCO} + 0.95$	0.24	-0.95	0.02

Notes:

1. A total of 200 mA per bank should not be exceeded.
2. The peak voltage of the overshoot or undershoot, and the duration above $V_{CCO} + 0.20V$ or below $GND - 0.20V$, must not exceed the values in this table.

Table 5: V_{IN} Maximum Allowed AC Voltage Overshoot and Undershoot for HP I/O Banks⁽¹⁾⁽²⁾

AC Voltage Overshoot	% of UI at -55°C to 125°C	AC Voltage Undershoot	% of UI at -55°C to 125°C
$V_{CCO} + 0.55$	100	-0.55	100
$V_{CCO} + 0.60$	50.0 ⁽³⁾	-0.60	50.0 ⁽³⁾
$V_{CCO} + 0.65$	50.0 ⁽³⁾	-0.65	50.0 ⁽³⁾
$V_{CCO} + 0.70$	47.0	-0.70	50.0 ⁽³⁾
$V_{CCO} + 0.75$	21.2	-0.75	50.0 ⁽³⁾
$V_{CCO} + 0.80$	9.71	-0.80	50.0 ⁽³⁾
$V_{CCO} + 0.85$	4.51	-0.85	28.4
$V_{CCO} + 0.90$	2.12	-0.90	12.7
$V_{CCO} + 0.95$	1.01	-0.95	5.79

Notes:

1. A total of 200 mA per bank should not be exceeded.
2. The peak voltage of the overshoot or undershoot, and the duration above $V_{CCO} + 0.20V$ or below $GND - 0.20V$, must not exceed the values in this table.
3. For UI lasting less than 20 μs .

Table 6: Typical Quiescent Supply Current

Symbol	Description	Device	Speed Grade								Units	
			1.0V							0.95V		0.9V
			-3	-2/-2LE	-1	-1LM	-1M	-1Q	-2LI	-2LE		
I_{CCINTQ}	Quiescent V_{CCINT} supply current	XC7K70T	241	241	241	N/A	N/A	N/A	N/A	187	mA	
		XC7K160T	474	474	474	N/A	N/A	N/A	271	368	mA	
		XC7K325T	810	810	810	N/A	N/A	N/A	463	629	mA	
		XC7K355T	993	993	993	N/A	N/A	N/A	568	771	mA	
		XC7K410T	1080	1080	1080	N/A	N/A	N/A	618	838	mA	
		XC7K420T	1313	1313	1313	N/A	N/A	N/A	751	1019	mA	
		XC7K480T	1313	1313	1313	N/A	N/A	N/A	751	1019	mA	
		XA7K160T	N/A	N/A	N/A	N/A	N/A	474	N/A	N/A	mA	
		XQ7K325T	N/A	810	810	810	810	N/A	463	629	mA	
XQ7K410T	N/A	1080	1080	N/A	1080	N/A	618	838	mA			

Table 6: Typical Quiescent Supply Current (Cont'd)

Symbol	Description	Device	Speed Grade								Units
			1.0V						0.95V	0.9V	
			-3	-2/-2LE	-1	-1LM	-1M	-1Q	-2LI	-2LE	
I _{CCOQ}	Quiescent V _{CCO} supply current	XC7K70T	1	1	1	N/A	N/A	N/A	N/A	1	mA
		XC7K160T	1	1	1	N/A	N/A	N/A	1	1	mA
		XC7K325T	1	1	1	N/A	N/A	N/A	1	1	mA
		XC7K355T	1	1	1	N/A	N/A	N/A	1	1	mA
		XC7K410T	1	1	1	N/A	N/A	N/A	1	1	mA
		XC7K420T	1	1	1	N/A	N/A	N/A	1	1	mA
		XC7K480T	1	1	1	N/A	N/A	N/A	1	1	mA
		XA7K160T	N/A	N/A	N/A	N/A	N/A	1	N/A	N/A	mA
		XQ7K325T	N/A	1	1	1	1	N/A	1	1	mA
XQ7K410T	N/A	1	1	N/A	1	N/A	1	1	mA		
I _{CCAUXQ}	Quiescent V _{CCAUX} supply current	XC7K70T	21	21	21	N/A	N/A	N/A	N/A	21	mA
		XC7K160T	40	40	40	N/A	N/A	N/A	36	40	mA
		XC7K325T	68	68	68	N/A	N/A	N/A	61	68	mA
		XC7K355T	75	75	75	N/A	N/A	N/A	67	75	mA
		XC7K410T	85	85	85	N/A	N/A	N/A	76	85	mA
		XC7K420T	99	99	99	N/A	N/A	N/A	89	99	mA
		XC7K480T	99	99	99	N/A	N/A	N/A	89	99	mA
		XA7K160T	N/A	N/A	N/A	N/A	N/A	40	N/A	N/A	mA
		XQ7K325T	N/A	68	68	68	68	N/A	68	68	mA
XQ7K410T	N/A	85	85	N/A	85	N/A	85	85	mA		
I _{CCAUX_IOQ}	Quiescent V _{CCAUX_IO} supply current	XC7K70T	N/A	N/A	N/A	N/A	N/A	N/A	N/A	N/A	mA
		XC7K160T	2	2	2	N/A	N/A	N/A	1	2	mA
		XC7K325T	2	2	2	N/A	N/A	N/A	1	2	mA
		XC7K355T	N/A	N/A	N/A	N/A	N/A	N/A	N/A	N/A	mA
		XC7K410T	2	2	2	N/A	N/A	N/A	1	2	mA
		XC7K420T	N/A	N/A	N/A	N/A	N/A	N/A	N/A	N/A	mA
		XC7K480T	N/A	N/A	N/A	N/A	N/A	N/A	N/A	N/A	mA
		XA7K160T	N/A	N/A	N/A	N/A	N/A	2	N/A	N/A	mA
		XQ7K325T	N/A	2	2	2	2	N/A	2	2	mA
XQ7K410T	N/A	2	2	N/A	2	N/A	2	2	mA		

Table 6: Typical Quiescent Supply Current (Cont'd)

Symbol	Description	Device	Speed Grade								Units
			1.0V						0.95V	0.9V	
			-3	-2/-2LE	-1	-1LM	-1M	-1Q	-2LI	-2LE	
I _{CCBRAMQ}	Quiescent V _{CCBRAM} supply current	XC7K70T	6	6	6	N/A	N/A	N/A	N/A	6	mA
		XC7K160T	14	14	14	N/A	N/A	N/A	8	14	mA
		XC7K325T	19	19	19	N/A	N/A	N/A	10	19	mA
		XC7K355T	31	31	31	N/A	N/A	N/A	17	31	mA
		XC7K410T	34	34	34	N/A	N/A	N/A	19	34	mA
		XC7K420T	41	41	41	N/A	N/A	N/A	23	41	mA
		XC7K480T	41	41	41	N/A	N/A	N/A	23	41	mA
		XA7K160T	N/A	N/A	N/A	N/A	N/A	14	N/A	N/A	mA
		XQ7K325T	N/A	19	19	19	19	N/A	19	19	mA
XQ7K410T	N/A	34	34	N/A	34	N/A	34	34	mA		

Notes:

1. Typical values are specified at nominal voltage, 85°C junction temperatures (T_j) with single-ended SelectIO resources.
2. Typical values are for blank configured devices with no output current loads, no active input pull-up resistors, all I/O pins are 3-state and floating.
3. Use the Xilinx Power Estimator (XPE) spreadsheet tool (download at www.xilinx.com/power) to estimate static power consumption for conditions other than those specified.

Power-On/Off Power Supply Sequencing

The recommended power-on sequence is V_{CCINT}, V_{CCBRAM}, V_{CCAUX}, V_{CCAUX_IO}, and V_{CCO} to achieve minimum current draw and ensure that the I/Os are 3-stated at power-on. The recommended power-off sequence is the reverse of the power-on sequence. If V_{CCINT} and V_{CCBRAM} have the same recommended voltage levels then both can be powered by the same supply and ramped simultaneously. If V_{CCAUX}, V_{CCAUX_IO}, and V_{CCO} have the same recommended voltage levels then they can be powered by the same supply and ramped simultaneously.

For V_{CCO} voltages of 3.3V in HR I/O banks and configuration bank 0:

- The voltage difference between V_{CCO} and V_{CCAUX} must not exceed 2.625V for longer than T_{VCCO2VCCAUX} for each power-on/off cycle to maintain device reliability levels.
- The T_{VCCO2VCCAUX} time can be allocated in any percentage between the power-on and power-off ramps.

The recommended power-on sequence to achieve minimum current draw for the GTX transceivers is V_{CCINT}, V_{MGTAVCC}, V_{MGTAVTT} OR V_{MGTAVCC}, V_{CCINT}, V_{MGTAVTT}. There is no recommended sequencing for V_{MGTVCCAUX}. Both V_{MGTAVCC} and V_{CCINT} can be ramped simultaneously. The recommended power-off sequence is the reverse of the power-on sequence to achieve minimum current draw.

If these recommended sequences are not met, current drawn from V_{MGTAVTT} can be higher than specifications during power-up and power-down.

- When V_{MGTAVTT} is powered before V_{MGTAVCC} and V_{MGTAVTT} - V_{MGTAVCC} > 150 mV and V_{MGTAVCC} < 0.7V, the V_{MGTAVTT} current draw can increase by 460 mA per transceiver during V_{MGTAVCC} ramp up. The duration of the current draw can be up to 0.3 x T_{MGTAVCC} (ramp time from GND to 90% of V_{MGTAVCC}). The reverse is true for power-down.
- When V_{MGTAVTT} is powered before V_{CCINT} and V_{MGTAVTT} - V_{CCINT} > 150 mV and V_{CCINT} < 0.7V, the V_{MGTAVTT} current draw can increase by 50 mA per transceiver during V_{CCINT} ramp up. The duration of the current draw can be up to 0.3 x T_{VCCINT} (ramp time from GND to 90% of V_{CCINT}). The reverse is true for power-down.

There is no recommended sequence for supplies not shown.

Table 7 shows the minimum current, in addition to I_{CCQ}, that are required by Kintex-7 devices for proper power-on and configuration. If the current minimums shown in Table 6 and Table 7 are met, the device powers on after all five supplies have passed through their power-on reset threshold voltages. The FPGA must not be configured until after V_{CCINT} is applied.

Once initialized and configured, use the Xilinx Power Estimator (XPE) spreadsheet tool (download at www.xilinx.com/power) to estimate current drain on these supplies.

Table 7: Power-On Current for Kintex-7 Devices

Device	I _{CCINTMIN}	I _{CCAUXMIN}	I _{CCOMIN}	I _{CCAUX_IOMIN}	I _{CCBRAMMIN}	Units
XC7K70T	I _{CCINTQ} + 450	I _{CCAUXQ} + 40	I _{CCOQ} + 40 mA per bank	I _{CCOAUXXIOQ} + 40 mA per bank	I _{CCBRAMQ} + 40	mA
XC7K160T	I _{CCINTQ} + 550	I _{CCAUXQ} + 50	I _{CCOQ} + 40 mA per bank	I _{CCOAUXXIOQ} + 40 mA per bank	I _{CCBRAMQ} + 40	mA
XC7K325T	I _{CCINTQ} + 600	I _{CCAUXQ} + 80	I _{CCOQ} + 40 mA per bank	I _{CCOAUXXIOQ} + 40 mA per bank	I _{CCBRAMQ} + 40	mA
XC7K355T	I _{CCINTQ} + 1450	I _{CCAUXQ} + 109	I _{CCOQ} + 40 mA per bank	I _{CCOAUXXIOQ} + 40 mA per bank	I _{CCBRAMQ} + 81	mA
XC7K410T	I _{CCINTQ} + 1500	I _{CCAUXQ} + 125	I _{CCOQ} + 40 mA per bank	I _{CCOAUXXIOQ} + 40 mA per bank	I _{CCBRAMQ} + 90	mA
XC7K420T	I _{CCINTQ} + 2200	I _{CCAUXQ} + 180	I _{CCOQ} + 40 mA per bank	I _{CCOAUXXIOQ} + 40 mA per bank	I _{CCBRAMQ} + 108	mA
XC7K480T	I _{CCINTQ} + 2200	I _{CCAUXQ} + 180	I _{CCOQ} + 40 mA per bank	I _{CCOAUXXIOQ} + 40 mA per bank	I _{CCBRAMQ} + 108	mA
XA7K160T	I _{CCINTQ} + 550	I _{CCAUXQ} + 50	I _{CCOQ} + 40 mA per bank	I _{CCOAUXXIOQ} + 40 mA per bank	I _{CCBRAMQ} + 40	mA
XQ7K325T	I _{CCINTQ} + 600	I _{CCAUXQ} + 80	I _{CCOQ} + 40 mA per bank	I _{CCOAUXXIOQ} + 40 mA per bank	I _{CCBRAMQ} + 40	mA
XQ7K410T	I _{CCINTQ} + 1500	I _{CCAUXQ} + 125	I _{CCOQ} + 40 mA per bank	I _{CCOAUXXIOQ} + 40 mA per bank	I _{CCBRAMQ} + 90	mA

Table 8: Power Supply Ramp Time

Symbol	Description	Conditions	Min	Max	Units
T _{VCCINT}	Ramp time from GND to 90% of V _{CCINT}		0.2	50	ms
T _{VCCO}	Ramp time from GND to 90% of V _{CCO}		0.2	50	ms
T _{VCCAUX}	Ramp time from GND to 90% of V _{CCAUX}		0.2	50	ms
T _{VCCAUX_IO}	Ramp time from GND to 90% of V _{CCAUX_IO}		0.2	50	ms
T _{VCCBRAM}	Ramp time from GND to 90% of V _{CCBRAM}		0.2	50	ms
T _{VCCO2VCCAUX}	Allowed time per power cycle for V _{CCO} – V _{CCAUX} > 2.625V	T _J = 125°C ⁽¹⁾	–	300	ms
		T _J = 100°C ⁽¹⁾	–	500	
		T _J = 85°C ⁽¹⁾	–	800	
T _{MGTAVCC}	Ramp time from GND to 90% of V _{MGTAVCC}		0.2	50	ms
T _{MGTAVTT}	Ramp time from GND to 90% of V _{MGTAVTT}		0.2	50	ms
T _{MGTVCCAUX}	Ramp time from GND to 90% of V _{MGTVCCAUX}		0.2	50	ms

Notes:

- Based on 240,000 power cycles with nominal V_{CCO} of 3.3V or 36,500 power cycles with a worst case V_{CCO} of 3.465V.

DC Input and Output Levels

Values for V_{IL} and V_{IH} are recommended input voltages. Values for I_{OL} and I_{OH} are guaranteed over the recommended operating conditions at the V_{OL} and V_{OH} test points. Only selected standards are tested. These are chosen to ensure that all standards meet their specifications. The selected standards are tested at a minimum V_{CCO} with the respective V_{OL} and V_{OH} voltage levels shown. Other standards are sample tested.

Table 9: SelectIO DC Input and Output Levels ⁽¹⁾⁽²⁾

I/O Standard	V _{IL}		V _{IH}		V _{OL}	V _{OH}	I _{OL}	I _{OH}
	V, Min	V, Max	V, Min	V, Max	V, Max	V, Min	mA	mA
HSTL_I	–0.300	V _{REF} – 0.100	V _{REF} + 0.100	V _{CCO} + 0.300	0.400	V _{CCO} – 0.400	8	–8
HSTL_I_12	–0.300	V _{REF} – 0.080	V _{REF} + 0.080	V _{CCO} + 0.300	25% V _{CCO}	75% V _{CCO}	6.3	–6.3
HSTL_I_18	–0.300	V _{REF} – 0.100	V _{REF} + 0.100	V _{CCO} + 0.300	0.400	V _{CCO} – 0.400	8	–8
HSTL_II	–0.300	V _{REF} – 0.100	V _{REF} + 0.100	V _{CCO} + 0.300	0.400	V _{CCO} – 0.400	16	–16

Table 9: SelectIO DC Input and Output Levels ⁽¹⁾⁽²⁾ (Cont'd)

I/O Standard	V _{IL}		V _{IH}		V _{OL}	V _{OH}	I _{OL}	I _{OH}
	V, Min	V, Max	V, Min	V, Max	V, Max	V, Min	mA	mA
HSTL_II_18	-0.300	V _{REF} - 0.100	V _{REF} + 0.100	V _{CCO} + 0.300	0.400	V _{CCO} - 0.400	16	-16
HSUL_12	-0.300	V _{REF} - 0.130	V _{REF} + 0.130	V _{CCO} + 0.300	20% V _{CCO}	80% V _{CCO}	0.1	-0.1
LVC MOS12	-0.300	35% V _{CCO}	65% V _{CCO}	V _{CCO} + 0.300	0.400	V _{CCO} - 0.400	Note 3	Note 3
LVC MOS15, LVDCI_15	-0.300	35% V _{CCO}	65% V _{CCO}	V _{CCO} + 0.300	25% V _{CCO}	75% V _{CCO}	Note 4	Note 4
LVC MOS18, LVDCI_18	-0.300	35% V _{CCO}	65% V _{CCO}	V _{CCO} + 0.300	0.450	V _{CCO} - 0.450	Note 5	Note 5
LVC MOS25	-0.300	0.700	1.700	V _{CCO} + 0.300	0.400	V _{CCO} - 0.400	Note 6	Note 6
LVC MOS33	-0.300	0.800	2.000	3.450	0.400	V _{CCO} - 0.400	Note 6	Note 6
LV TTL	-0.300	0.800	2.000	3.450	0.400	2.400	Note 7	Note 7
MOBILE_DDR	-0.300	20% V _{CCO}	80% V _{CCO}	V _{CCO} + 0.300	10% V _{CCO}	90% V _{CCO}	0.1	-0.1
PCI33_3	-0.400	30% V _{CCO}	50% V _{CCO}	V _{CCO} + 0.500	10% V _{CCO}	90% V _{CCO}	1.5	-0.5
SSTL12	-0.300	V _{REF} - 0.100	V _{REF} + 0.100	V _{CCO} + 0.300	V _{CCO} /2 - 0.150	V _{CCO} /2 + 0.150	14.25	-14.25
SSTL135	-0.300	V _{REF} - 0.090	V _{REF} + 0.090	V _{CCO} + 0.300	V _{CCO} /2 - 0.150	V _{CCO} /2 + 0.150	13.0	-13.0
SSTL135_R	-0.300	V _{REF} - 0.090	V _{REF} + 0.090	V _{CCO} + 0.300	V _{CCO} /2 - 0.150	V _{CCO} /2 + 0.150	8.9	-8.9
SSTL15	-0.300	V _{REF} - 0.100	V _{REF} + 0.100	V _{CCO} + 0.300	V _{CCO} /2 - 0.175	V _{CCO} /2 + 0.175	13.0	-13.0
SSTL15_R	-0.300	V _{REF} - 0.100	V _{REF} + 0.100	V _{CCO} + 0.300	V _{CCO} /2 - 0.175	V _{CCO} /2 + 0.175	8.9	-8.9
SSTL18_I	-0.300	V _{REF} - 0.125	V _{REF} + 0.125	V _{CCO} + 0.300	V _{CCO} /2 - 0.470	V _{CCO} /2 + 0.470	8	-8
SSTL18_II	-0.300	V _{REF} - 0.125	V _{REF} + 0.125	V _{CCO} + 0.300	V _{CCO} /2 - 0.600	V _{CCO} /2 + 0.600	13.4	-13.4

Notes:

1. Tested according to relevant specifications.
2. 3.3V and 2.5V standards are only supported in HR I/O banks.
3. Supported drive strengths of 2, 4, 6, or 8 mA in HP I/O banks and 4, 8, or 12 mA in HR I/O banks.
4. Supported drive strengths of 2, 4, 6, 8, 12, or 16 mA in HP I/O banks and 4, 8, 12, or 16 mA in HR I/O banks.
5. Supported drive strengths of 2, 4, 6, 8, 12, or 16 mA in HP I/O banks and 4, 8, 12, 16, or 24 mA in HR I/O banks.
6. Supported drive strengths of 4, 8, 12, or 16 mA
7. Supported drive strengths of 4, 8, 12, 16, or 24 mA
8. For detailed interface specific DC voltage levels, see the *7 Series FPGAs SelectIO Resources User Guide* ([UG471](#)).

Table 10: Differential SelectIO DC Input and Output Levels

I/O Standard	$V_{ICM}^{(1)}$			$V_{ID}^{(2)}$			$V_{OCM}^{(3)}$			$V_{OD}^{(4)}$		
	V, Min	V, Typ	V, Max	V, Min	V, Typ	V, Max	V, Min	V, Typ	V, Max	V, Min	V, Typ	V, Max
BLVDS_25	0.300	1.200	1.425	0.100	–	–	–	1.250	–	Note 5		
MINI_LVDS_25	0.300	1.200	V_{CCAUX}	0.200	0.400	0.600	1.000	1.200	1.400	0.300	0.450	0.600
PPDS_25	0.200	0.900	V_{CCAUX}	0.100	0.250	0.400	0.500	0.950	1.400	0.100	0.250	0.400
RSDS_25	0.300	0.900	1.500	0.100	0.350	0.600	1.000	1.200	1.400	0.100	0.350	0.600
TMDS_33	2.700	2.965	3.230	0.150	0.675	1.200	$V_{CCO}-0.405$	$V_{CCO}-0.300$	$V_{CCO}-0.190$	0.400	0.600	0.800

Notes:

1. V_{ICM} is the input common mode voltage.
2. V_{ID} is the input differential voltage ($Q - \bar{Q}$).
3. V_{OCM} is the output common mode voltage.
4. V_{OD} is the output differential voltage ($Q - \bar{Q}$).
5. V_{OD} for BLVDS will vary significantly depending on topology and loading.
6. LVDS_25 is specified in Table 12.
7. LVDS is specified in Table 13.

Table 11: Complementary Differential SelectIO DC Input and Output Levels

I/O Standard	$V_{ICM}^{(1)}$			$V_{ID}^{(2)}$		$V_{OL}^{(3)}$	$V_{OH}^{(4)}$	I_{OL}	I_{OH}
	V, Min	V, Typ	V, Max	V, Min	V, Max	V, Max	V, Min	mA, Max	mA, Min
DIFF_HSTL_I	0.300	0.750	1.125	0.100	–	0.400	$V_{CCO}-0.400$	8.00	–8.00
DIFF_HSTL_I_18	0.300	0.900	1.425	0.100	–	0.400	$V_{CCO}-0.400$	8.00	–8.00
DIFF_HSTL_II	0.300	0.750	1.125	0.100	–	0.400	$V_{CCO}-0.400$	16.00	–16.00
DIFF_HSTL_II_18	0.300	0.900	1.425	0.100	–	0.400	$V_{CCO}-0.400$	16.00	–16.00
DIFF_HSUL_12	0.300	0.600	0.850	0.100	–	20% V_{CCO}	80% V_{CCO}	0.100	–0.100
DIFF_MOBILE_DDR	0.300	0.900	1.425	0.100	–	10% V_{CCO}	90% V_{CCO}	0.100	–0.100
DIFF_SSTL12	0.300	0.600	0.850	0.100	–	$(V_{CCO}/2) - 0.150$	$(V_{CCO}/2) + 0.150$	14.25	–14.25
DIFF_SSTL135	0.300	0.675	1.000	0.100	–	$(V_{CCO}/2) - 0.150$	$(V_{CCO}/2) + 0.150$	13.0	–13.0
DIFF_SSTL135_R	0.300	0.675	1.000	0.100	–	$(V_{CCO}/2) - 0.150$	$(V_{CCO}/2) + 0.150$	8.9	–8.9
DIFF_SSTL15	0.300	0.750	1.125	0.100	–	$(V_{CCO}/2) - 0.175$	$(V_{CCO}/2) + 0.175$	13.0	–13.0
DIFF_SSTL15_R	0.300	0.750	1.125	0.100	–	$(V_{CCO}/2) - 0.175$	$(V_{CCO}/2) + 0.175$	8.9	–8.9
DIFF_SSTL18_I	0.300	0.900	1.425	0.100	–	$(V_{CCO}/2) - 0.470$	$(V_{CCO}/2) + 0.470$	8.00	–8.00
DIFF_SSTL18_II	0.300	0.900	1.425	0.100	–	$(V_{CCO}/2) - 0.600$	$(V_{CCO}/2) + 0.600$	13.4	–13.4

Notes:

1. V_{ICM} is the input common mode voltage.
2. V_{ID} is the input differential voltage ($Q - \bar{Q}$).
3. V_{OL} is the single-ended low-output voltage.
4. V_{OH} is the single-ended high-output voltage.

LVDS DC Specifications (LVDS_25)

The LVDS_25 standard is available in the HR I/O banks. See the *7 Series FPGAs SelectIO Resources User Guide* ([UG471](#)) for more information.

Table 12: LVDS_25 DC Specifications

Symbol	DC Parameter	Conditions	Min	Typ	Max	Units
V_{CCO}	Supply Voltage		2.375	2.500	2.625	V
V_{OH}	Output High Voltage for Q and \bar{Q}	$R_T = 100 \Omega$ across Q and \bar{Q} signals	–	–	1.675	V
V_{OL}	Output Low Voltage for Q and \bar{Q}	$R_T = 100 \Omega$ across Q and \bar{Q} signals	0.700	–	–	V
V_{ODIFF}	Differential Output Voltage: (Q – \bar{Q}), Q = High (\bar{Q} – Q), \bar{Q} = High	$R_T = 100 \Omega$ across Q and \bar{Q} signals	247	350	600	mV
V_{OCM}	Output Common-Mode Voltage	$R_T = 100 \Omega$ across Q and \bar{Q} signals	1.000	1.250	1.425	V
V_{IDIFF}	Differential Input Voltage: (Q – \bar{Q}), Q = High (\bar{Q} – Q), \bar{Q} = High		100	350	600	mV
V_{ICM}	Input Common-Mode Voltage		0.300	1.200	1.500	V

Notes:

- Differential inputs for LVDS_25 can be placed in banks with V_{CCO} levels that are different from the required level for outputs. Refer to the *7 Series FPGAs SelectIO Resources User Guide* ([UG471](#)) for more information.

LVDS DC Specifications (LVDS)

The LVDS standard is available in the HP I/O banks. See the *7 Series FPGAs SelectIO Resources User Guide* ([UG471](#)) for more information.

Table 13: LVDS DC Specifications

Symbol	DC Parameter	Conditions	Min	Typ	Max	Units
V_{CCO}	Supply Voltage		1.710	1.800	1.890	V
V_{OH}	Output High Voltage for Q and \bar{Q}	$R_T = 100 \Omega$ across Q and \bar{Q} signals	–	–	1.675	V
V_{OL}	Output Low Voltage for Q and \bar{Q}	$R_T = 100 \Omega$ across Q and \bar{Q} signals	0.825	–	–	V
V_{ODIFF}	Differential Output Voltage: (Q – \bar{Q}), Q = High (\bar{Q} – Q), \bar{Q} = High	$R_T = 100 \Omega$ across Q and \bar{Q} signals	247	350	600	mV
V_{OCM}	Output Common-Mode Voltage	$R_T = 100 \Omega$ across Q and \bar{Q} signals	1.000	1.250	1.425	V
V_{IDIFF}	Differential Input Voltage: (Q – \bar{Q}), Q = High (\bar{Q} – Q), \bar{Q} = High	Common-mode input voltage = 1.25V	100	350	600	mV
V_{ICM}	Input Common-Mode Voltage	Differential input voltage = ± 350 mV	0.300	1.200	1.425	V

Notes:

- Differential inputs for LVDS can be placed in banks with V_{CCO} levels that are different from the required level for outputs. Refer to the *7 Series FPGAs SelectIO Resources User Guide* ([UG471](#)) for more information.

AC Switching Characteristics

All values represented in this data sheet are based on the speed specifications in the Vivado® Design Suite 2015.4 and ISE® software 14.7 as outlined in [Table 14](#).

Table 14: Kintex-7 FPGA Speed Specification Version By Device

Version In:		Typical V _{CCINT}	Device
ISE 14.7	Vivado 2019.1.1	(Table 2)	
1.10	1.12	1.0V	XC7K70T ⁽¹⁾ , XC7K160T ⁽¹⁾ , XC7K325T, XC7K355T, XC7K410T, XC7K420T, XC7K480T
N/A	1.12	0.95V	XC7K160T ⁽¹⁾ , XC7K325T, XC7K355T, XC7K410T, XC7K420T, XC7K480T
1.09	1.09	0.9V	XC7K70T, XC7K160T, XC7K325T, XC7K355T, XC7K410T, XC7K420T, XC7K480T
N/A	1.02	1.0V	XA7K160T
1.05	1.09	1.0V	XQ7K325T, XQ7K410T
1.05	1.07	0.9V	XQ7K325T, XQ7K410T

Notes:

1. GTX data rates greater than 6.6 Gb/s in the FBG484 package in the -3 and -2 speed grades require Vivado Design Suite 2017.1 or later.

Switching characteristics are specified on a per-speed-grade basis and can be designated as Advance, Preliminary, or Production. Each designation is defined as follows:

Advance Product Specification

These specifications are based on simulations only and are typically available soon after device design specifications are frozen. Although speed grades with this designation are considered relatively stable and conservative, some under-reporting might still occur.

Preliminary Product Specification

These specifications are based on complete ES (engineering sample) silicon characterization. Devices and speed grades with this designation are intended to give a better indication of the expected performance of production silicon. The probability of under-reporting delays is greatly reduced as compared to Advance data.

Product Specification

These specifications are released once enough production silicon of a particular device family member has been characterized to provide full correlation between specifications and devices over numerous production lots. There is no under-reporting of delays, and customers receive formal notification of any subsequent changes. Typically, the slowest speed grades transition to production before faster speed grades.

Testing of AC Switching Characteristics

Internal timing parameters are derived from measuring internal test patterns. All AC switching characteristics are representative of worst-case supply voltage and junction temperature conditions.

For more specific, more precise, and worst-case guaranteed data, use the values reported by the static timing analyzer and back-annotate to the simulation net list. Unless otherwise noted, values apply to all Kintex-7 FPGAs.

Speed Grade Designations

Since individual family members are produced at different times, the migration from one category to another depends completely on the status of the fabrication process for each device. [Table 15](#) correlates the current status of each Kintex-7 device on a per speed grade basis.

Table 15: Kintex-7 Device Speed Grade Designations

Device	Speed Grade Designations		
	Advance	Preliminary	Production
XC7K70T			-3, -2, -2LE(1.0V), -1, and -2LE (0.9V)
XC7K160T			-3, -2, -2LE(1.0V), -2LI (0.95V), -1, and -2LE (0.9V)
XC7K325T			-3, -2, -2LE(1.0V), -2LI (0.95V), -1, and -2LE (0.9V)
XC7K355T			-3, -2, -2LE(1.0V), -2LI (0.95V), -1, and -2LE (0.9V)
XC7K410T			-3, -2, -2LE(1.0V), -2LI (0.95V), -1, and -2LE (0.9V)
XC7K420T			-3, -2, -2LE(1.0V), -2LI (0.95V), -1, and -2LE (0.9V)
XC7K480T			-3, -2, -2LE(1.0V), -2LI (0.95V), -1, and -2LE (0.9V)
XA7K160T			-1Q
XQ7K325T			-2I, -2LE(1.0V), -1I, -2LE(0.9V), -2LI (0.95V), -1LM, and -1M
XQ7K410T			-2I, -2LE(1.0V), -1I, -2LE(0.9V), -2LI (0.95V), and -1M

Production Silicon and Software Status

In some cases, a particular family member (and speed grade) is released to production before a speed specification is released with the correct label (Advance, Preliminary, Production). Any labeling discrepancies are corrected in subsequent speed specification releases.

[Table 16](#) lists the production released Kintex-7 device, speed grade, and the minimum corresponding supported speed specification version and software revisions. The software and speed specifications listed are the minimum releases required for production. All subsequent releases of software and speed specifications are valid.

Table 16: Kintex-7 Device Production Software and Speed Specification Release

Device	Speed Grade Designations							
	1.0V						0.95V	0.9V
	-3	-2/-2LE	-1	-1M	-1LM	-1Q	-2LI	-2LE
XC7K70T	Vivado tools 2012.4 v1.08 or ISE tools 14.2 v1.06		N/A	N/A	N/A	N/A	N/A	Vivado tools 2012.4 v1.07 or ISE tools 14.3 v1.06
XC7K160T	Vivado tools 2012.4 v1.08 or ISE tools 14.2 v1.06		N/A	N/A	N/A	N/A	Vivado tools 2014.4 v1.12	Vivado tools 2012.4 v1.07 or ISE tools 14.3 v1.06
XC7K325T	Vivado tools 2012.4 v1.08 or ISE tools 14.2 v1.06		N/A	N/A	N/A	N/A	Vivado tools 2014.4 v1.12	Vivado tools 2012.4 v1.07 or ISE tools 14.3 v1.06
XC7K355T	Vivado tools 2012.4 v1.08 or ISE tools 14.2 v1.06		N/A	N/A	N/A	N/A	Vivado tools 2014.4 v1.12	Vivado tools 2012.4 v1.07 or ISE tools 14.3 v1.06
XC7K410T	Vivado tools 2012.4 v1.08 or ISE tools 14.2 v1.06		N/A	N/A	N/A	N/A	Vivado tools 2014.4 v1.12	Vivado tools 2012.4 v1.07 or ISE tools 14.3 v1.06
XC7K420T	Vivado tools 2012.4 v1.08 or ISE tools 14.2 v1.06		N/A	N/A	N/A	N/A	Vivado tools 2014.4 v1.12	Vivado tools 2012.4 v1.07 or ISE tools 14.3 v1.06
XC7K480T	Vivado tools 2012.4 v1.08 or ISE tools 14.2 v1.06		N/A	N/A	N/A	N/A	Vivado tools 2014.4 v1.12	Vivado tools 2012.4 v1.07 or ISE tools 14.3 v1.06
XA7K160T	N/A	N/A	N/A	N/A	N/A	Vivado tools 2019.1.1 v1.02	N/A	N/A

Table 16: Kintex-7 Device Production Software and Speed Specification Release (Cont'd)

Device	Speed Grade Designations							
	1.0V					0.95V	0.9V	
	-3	-2/-2LE	-1	-1M	-1LM	-1Q	-2LI	-2LE
XQ7K325T	N/A	Vivado tools 2013.1 v1.04 or ISE tools 14.5 v1.04		Vivado tools 2015.4 v1.09		N/A	Vivado tools 2015.4 v1.07	Vivado tools 2013.1 v1.04 or ISE tools 14.5 v1.04
XQ7K410T	N/A	Vivado tools 2013.1 v1.04 or ISE tools 14.5 v1.04		N/A		N/A	Vivado tools 2015.4 v1.07	Vivado tools 2013.1 v1.04 or ISE tools 14.5 v1.04

Selecting the Correct Speed Grade and Voltage in the Vivado Tools

It is important to select the correct device speed grade and voltage in the Vivado tools for the device that you are selecting.

To select the 1.0V speed specifications in the Vivado tools, select the **Kintex-7, Defense Grade Kintex-7Q, or XA Kintex-7** sub-family, and then select the part name that is the device name followed by the package name followed by the speed grade. For example, select the **xc7k325tffg900-3** part name for the XC7K325T device in the FFG900 package and -3 (1.0V) speed grade or select the **xc7k325tffg900-2L** part name for the XC7K325T device in the FFG900 package and -2LE (1.0V) speed grade.

To select the -2LI (0.95V) speed specifications in the Vivado tools, select the **Kintex-7** sub-family and then select the part name that is the device name followed by an *i* followed by the package name followed by the speed grade. For example, select the **xc7k325tiffg900-2L** part name for the XC7K325T device in the FFG900 package and -2LI (0.95V) speed grade. The -2LI (0.95V) speed specifications are not supported in the ISE tools.

To select the -2LE (0.9V) speed specifications in the Vivado tools, select the **Kintex-7 Low Voltage or Defense Grade Kintex-7Q Low Voltage** sub-family, and then select the part name that is the device name followed by an *l* followed by the package name followed by the speed grade. For example, select the **xc7k325tlffg900-2L** part name for the XC7K325T device in the FFG900 package and -2LE (0.9V) speed grade.

A similar part naming convention applies to the speed specifications selection in the ISE tools for supported devices. See [Table 16](#) for the subset of 7 series FPGAs supported in the ISE tools.

Performance Characteristics

This section provides the performance characteristics of some common functions and designs implemented in Kintex-7 devices. The numbers reported here are worst-case values; they have all been fully characterized. These values are subject to the same guidelines as the [AC Switching Characteristics, page 12](#). In each table, the I/O bank type is either High Performance (HP) or High Range (HR).

Table 17: Networking Applications Interface Performances

Description	I/O Bank Type	Speed Grade					Units
		1.0V			0.95V	0.9V	
		-3	-2/-2LE	-1/-1M/-1LM/-1Q	-2LI	-2LE	
SDR LVDS transmitter (using OSERDES; DATA_WIDTH = 4 to 8)	HR	710	710	625	710	625	Mb/s
	HP	710	710	625	710	625	Mb/s
DDR LVDS transmitter (using OSERDES; DATA_WIDTH = 4 to 14)	HR	1250	1250	950	1250	950	Mb/s
	HP	1600	1400	1250	1400	1250	Mb/s
SDR LVDS receiver (SFI-4.1) ⁽¹⁾	HR	710	710	625	710	625	Mb/s
	HP	710	710	625	710	625	Mb/s
DDR LVDS receiver (SPI-4.2) ⁽¹⁾	HR	1250	1250	950	1250	950	Mb/s
	HP	1600	1400	1250	1400	1250	Mb/s

Notes:

1. LVDS receivers are typically bounded with certain applications where specific dynamic phase-alignment (DPA) algorithms dominate deterministic performance.

Table 18 and Table 19 provide the maximum data rates for applicable memory standards using the Kintex-7 FPGAs memory PHY. The final performance of the memory interface is determined through a complete design implemented in the Vivado or ISE Design Suite, following guidelines in the *Zynq-7000 SoC and 7 Series Devices Memory Interface Solutions User Guide (UG586)*, electrical analysis, and characterization of the system.

Table 18: Maximum Physical Interface (PHY) Rate for Memory Interfaces IP available with the Memory Interface Generator (FF and RF Packages)⁽¹⁾⁽²⁾

Memory Standard	I/O Bank Type	V _{CCAUX_IO}	Speed Grade						Units
			1.0V				0.95V	0.9V	
			-3	-2/-2LE	-1	-1M/-1LM/-1Q	-2LI	-2LE	
4:1 Memory Controllers									
DDR3	HP	2.0V	1866 ⁽³⁾	1866 ⁽³⁾	1600	1066	1600	1333	Mb/s
	HP	1.8V	1600	1333	1066	800	1333	1066	Mb/s
	HR	N/A	1066	1066	800	800	1066	800	Mb/s
DDR3L	HP	2.0V	1600	1600	1333	1066	1600	1066	Mb/s
	HP	1.8V	1333	1066	800	800	1066	800	Mb/s
	HR	N/A	800	800	667	N/A	800	667	Mb/s
DDR2	HP	2.0V	800	800	800	667	800	800	Mb/s
	HP	1.8V	800	800	800	667	800	800	Mb/s
	HR	N/A	800	800	800	533	800	800	Mb/s
RLDRAM III	HP	2.0V	800	667	667	550	667	533	MHz
	HP	1.8V	550	500	450	400	500	450	MHz
	HR	N/A	N/A						
2:1 Memory Controllers									
DDR3	HP	2.0V	1066	1066	800	667	1066	800	Mb/s
	HP	1.8V	1066	1066	800	667	1066	800	Mb/s
	HR	N/A	1066	1066	800	667	1066	800	Mb/s
DDR3L	HP	2.0V	1066	1066	800	667	1066	800	Mb/s
	HP	1.8V	1066	1066	800	667	1066	800	Mb/s
	HR	N/A	800	800	667	N/A	800	667	Mb/s
DDR2	HP	2.0V	800	800	800	667	800	800	Mb/s
	HP	1.8V				667			
	HR	N/A				533			
QDR II+ ⁽⁴⁾	HP	2.0V	550	500	450	300	500	450	MHz
	HP	1.8V	500	450	400	300	450	400	MHz
	HR	N/A							
RLDRAM II	HP	2.0V	533	500	450	400	500	450	MHz
	HP	1.8V							
	HR	N/A							

Table 18: Maximum Physical Interface (PHY) Rate for Memory Interfaces IP available with the Memory Interface Generator (FF and RF Packages)⁽¹⁾⁽²⁾ (Cont'd)

Memory Standard	I/O Bank Type	V _{CCAUX_IO}	Speed Grade						Units
			1.0V				0.95V	0.9V	
			-3	-2/-2LE	-1	-1M/-1LM/-1Q	-2LI	-2LE	
LPDDR2	HP	2.0V	667	667	667	533	667	667	Mb/s
	HP	1.8V	667	667	667	533	667	667	Mb/s
	HR	N/A	667	667	667	533	667	667	Mb/s

Notes:

- V_{REF} tracking is required. For more information, see the *Zynq-7000 SoC and 7 Series Devices Memory Interface Solutions User Guide (UG586)*.
- When using the internal V_{REF}, the maximum data rate is 800 Mb/s (400 MHz).
- For designs using 1866 Mb/s components, contact [Xilinx Technical Support](#).
- The maximum QDR II+ performance specifications are for burst-length 4 (BL = 4) implementations. Burst length 2 (BL = 2) implementations are limited to 333 MHz for all speed grades and I/O bank types.

Table 19: Maximum Physical Interface (PHY) Rate for Memory Interfaces IP available with the Memory Interface Generator (FB Packages)⁽¹⁾⁽²⁾

Memory Standard	I/O Bank Type	V _{CCAUX_IO} ⁽³⁾	Speed Grade						Units
			1.0V				0.95V	0.9V	
			-3	-2/-2LE	-1	-1M/-1LM/-1Q	-2LI	-2LE	
4:1 Memory Controllers									
DDR3	HP	N/A	1333	1066	800	800	1066	800	Mb/s
	HR	N/A	1066	800	800	800	800	800	Mb/s
DDR3L	HP	N/A	1066	800	667	667	800	667	Mb/s
	HR	N/A	800	800	667	N/A	800	667	Mb/s
DDR2	HP	N/A	800	800	800	667	800	800	Mb/s
	HR	N/A	800	667	667	533	667	667	Mb/s
RLDRAM III	HP	N/A	550	500	450	350	500	450	MHz
	HR	N/A	N/A						
2:1 Memory Controllers									
DDR3	HP	N/A	1066	1066	800	667	1066	800	Mb/s
	HR	N/A	1066	800	800	667	800	800	Mb/s
DDR3L	HP	N/A	1066	800	667	667	800	667	Mb/s
	HR	N/A	800	800	667	N/A	800	667	Mb/s
DDR2	HP	N/A	800	800	800	667	800	800	Mb/s
	HR	N/A	800	667	667	533	667	667	Mb/s
QDR II+ ⁽⁴⁾	HP	N/A	550	500	450	300	500	450	MHz
	HR	N/A	450	400	350	300	400	350	MHz
RLDRAM II	HP	N/A	533	500	450	400	500	450	MHz
	HR	N/A							

Table 19: Maximum Physical Interface (PHY) Rate for Memory Interfaces IP available with the Memory Interface Generator (FB Packages)⁽¹⁾⁽²⁾ (Cont'd)

Memory Standard	I/O Bank Type	V _{CCAUX_IO} ⁽³⁾	Speed Grade						Units
			1.0V				0.95V	0.9V	
			-3	-2/-2LE	-1	-1M/-1LM/-1Q	-2LI	-2LE	
LPDDR2	HP	N/A	667	667	667	400	667	667	Mb/s
	HR	N/A	667	667	533	400	667	533	Mb/s

Notes:

1. V_{REF} tracking is required. For more information, see the *Zynq-7000 SoC and 7 Series Devices Memory Interface Solutions User Guide (UG586)*.
2. When using the internal V_{REF}, the maximum data rate is 800 Mb/s (400 MHz).
3. FB packages do not have separate V_{CCAUX_IO} supply pins to adjust the pre-driver voltage of the HP I/O banks.
4. The maximum QDRII+ performance specifications are for burst-length 4 (BL = 4) implementations. Burst length 2 (BL = 2) implementations are limited to 333 MHz for all speed grades and I/O bank types.

IOB Pad Input/Output/3-State

Table 20 (high-range IOB (HR)) and Table 21 (high-performance IOB (HP)) summarizes the values of standard-specific data input delay adjustments, output delays terminating at pads (based on standard) and 3-state delays.

- T_{IOPI} is described as the delay from IOB pad through the input buffer to the I-pin of an IOB pad. The delay varies depending on the capability of the SelectIO input buffer.
- T_{IOOP} is described as the delay from the O pin to the IOB pad through the output buffer of an IOB pad. The delay varies depending on the capability of the SelectIO output buffer.
- T_{IOTP} is described as the delay from the T pin to the IOB pad through the output buffer of an IOB pad, when 3-state is disabled. The delay varies depending on the SelectIO capability of the output buffer. In HP I/O banks, the internal DCI termination turn-on time is always faster than T_{IOTP} when the DCITERMDISABLE pin is used. In HR I/O banks, the IN_TERM termination turn-on time is always faster than T_{IOTP} when the INTERMDISABLE pin is used.

Table 20: IOB High Range (HR) Switching Characteristics

I/O Standard	T_{IOPI}						T_{IOOP}						T_{IOTP}						Units
	Speed Grade						Speed Grade						Speed Grade						
	1.0V			0.95V	0.9V		1.0V			0.95V	0.9V		1.0V			0.95V	0.9V		
	-3	-2/ -2LE	-1	-1M/ -1LM/ -1Q	-2LI	-2LE	-3	-2/ -2LE	-1	-1M/ -1LM/ -1Q	-2LI	-2LE	-3	-2/ -2LE	-1	-1M/ -1LM/ -1Q	-2LI	-2LE	
LVTTL_S4	1.31	1.42	1.64	1.64	1.42	1.51	3.77	3.90	4.00	4.00	3.90	4.13	3.52	3.67	3.86	3.86	3.67	3.85	ns
LVTTL_S8	1.31	1.42	1.64	1.64	1.42	1.51	3.50	3.64	3.73	3.73	3.64	3.86	3.26	3.40	3.60	3.60	3.40	3.58	ns
LVTTL_S12	1.31	1.42	1.64	1.64	1.42	1.51	3.49	3.62	3.72	3.72	3.62	3.84	3.24	3.39	3.58	3.58	3.39	3.56	ns
LVTTL_S16	1.31	1.42	1.64	1.64	1.42	1.51	3.03	3.17	3.26	3.26	3.17	3.39	2.79	2.93	3.13	3.13	2.93	3.11	ns
LVTTL_S24	1.31	1.42	1.64	1.64	1.42	1.51	3.25	3.39	3.48	3.48	3.39	3.61	3.01	3.15	3.35	3.35	3.15	3.33	ns
LVTTL_F4	1.31	1.42	1.64	1.64	1.42	1.51	3.22	3.36	3.45	3.45	3.36	3.58	2.98	3.12	3.32	3.32	3.12	3.30	ns
LVTTL_F8	1.31	1.42	1.64	1.64	1.42	1.51	2.71	2.84	2.93	2.93	2.84	3.06	2.46	2.61	2.80	2.80	2.61	2.78	ns
LVTTL_F12	1.31	1.42	1.64	1.64	1.42	1.51	2.69	2.82	2.92	2.92	2.82	3.05	2.44	2.59	2.79	2.79	2.59	2.77	ns
LVTTL_F16	1.31	1.42	1.64	1.64	1.42	1.51	2.57	2.85	3.15	3.15	2.85	2.88	2.33	2.61	3.02	3.02	2.61	2.60	ns
LVTTL_F24	1.31	1.42	1.64	1.64	1.42	1.51	2.41	2.64	2.89	3.04	2.64	2.94	2.16	2.41	2.76	2.91	2.41	2.66	ns
LVDS_25	0.64	0.68	0.80	0.87	0.68	0.83	1.36	1.47	1.55	1.55	1.47	1.58	1.11	1.24	1.41	1.41	1.24	1.30	ns
MINI_LVDS_25	0.68	0.70	0.79	0.87	0.70	0.83	1.36	1.47	1.55	1.55	1.47	1.59	1.11	1.24	1.41	1.41	1.24	1.31	ns
BLVDS_25	0.65	0.69	0.80	0.85	0.69	0.83	1.83	2.02	2.20	2.57	2.02	2.16	1.59	1.79	2.07	2.44	1.79	1.88	ns
RSDS_25 (point to point)	0.63	0.68	0.79	0.87	0.68	0.83	1.36	1.48	1.55	1.55	1.48	1.59	1.11	1.24	1.41	1.41	1.24	1.31	ns
PPDS_25	0.65	0.69	0.80	0.87	0.69	0.83	1.36	1.49	1.58	1.58	1.49	1.59	1.11	1.25	1.45	1.45	1.25	1.31	ns
TMDS_33	0.72	0.76	0.86	0.90	0.76	0.83	1.43	1.54	1.60	1.60	1.54	1.70	1.18	1.31	1.47	1.47	1.31	1.42	ns
PCI33_3	1.28	1.41	1.65	1.65	1.41	1.50	2.71	3.08	3.52	3.52	3.08	3.42	2.46	2.84	3.39	3.39	2.84	3.14	ns
HSUL_12_S	0.63	0.64	0.71	0.85	0.64	0.79	1.77	1.90	2.00	2.00	1.90	2.13	1.52	1.67	1.86	1.86	1.67	1.85	ns
HSUL_12_F	0.63	0.64	0.71	0.85	0.64	0.79	1.26	1.40	1.50	1.50	1.40	1.61	1.01	1.16	1.37	1.37	1.16	1.33	ns
DIFF_HSUL_12_S	0.58	0.61	0.70	0.84	0.61	0.81	1.55	1.68	1.78	1.78	1.68	1.92	1.30	1.45	1.65	1.65	1.45	1.64	ns
DIFF_HSUL_12_F	0.58	0.61	0.70	0.84	0.61	0.81	1.16	1.28	1.35	1.35	1.28	1.50	0.92	1.04	1.21	1.21	1.04	1.22	ns
MOBILE_DDR_S	0.64	0.66	0.74	0.74	0.66	0.89	2.58	2.91	3.31	3.31	2.91	1.95	2.33	2.68	3.17	3.17	2.68	1.67	ns
MOBILE_DDR_F	0.64	0.66	0.74	0.74	0.66	0.89	1.91	2.13	2.36	2.36	2.13	1.69	1.66	1.89	2.23	2.23	1.89	1.41	ns
DIFF_MOBILE_DDR_S	0.63	0.66	0.75	0.75	0.66	0.79	2.51	2.84	3.24	3.24	2.84	1.95	2.26	2.61	3.10	3.10	2.61	1.67	ns

Table 20: IOB High Range (HR) Switching Characteristics (Cont'd)

I/O Standard	T _{IOPI}						T _{IOOP}						T _{IOTP}						Units
	Speed Grade						Speed Grade						Speed Grade						
	1.0V			0.95V	0.9V	1.0V			0.95V	0.9V	1.0V			0.95V	0.9V				
	-3	-2/ -2LE	-1	-1M/ -1LM/ -1Q	-2LI	-2LE	-3	-2/ -2LE	-1	-1M/ -1LM/ -1Q	-2LI	-2LE	-3	-2/ -2LE	-1	-1M/ -1LM/ -1Q	-2LI	-2LE	
DIFF_MOBILE_DDR_F	0.63	0.66	0.75	0.75	0.66	0.79	1.89	2.11	2.34	2.34	2.11	1.72	1.64	1.88	2.21	2.21	1.88	1.44	ns
HSTL_I_S	0.61	0.64	0.73	0.84	0.64	0.79	1.55	1.69	1.80	1.80	1.69	1.91	1.30	1.46	1.67	1.67	1.46	1.63	ns
HSTL_II_S	0.61	0.64	0.73	0.84	0.64	0.78	1.21	1.34	1.43	1.61	1.34	1.70	0.96	1.11	1.30	1.47	1.11	1.42	ns
HSTL_I_18_S	0.64	0.67	0.76	0.85	0.67	0.79	1.28	1.39	1.45	1.45	1.39	1.58	1.04	1.16	1.31	1.32	1.16	1.30	ns
HSTL_II_18_S	0.64	0.67	0.76	0.85	0.67	0.79	1.18	1.31	1.40	1.57	1.31	1.69	0.93	1.08	1.27	1.44	1.08	1.41	ns
DIFF_HSTL_I_S	0.63	0.67	0.77	0.84	0.67	0.78	1.42	1.54	1.61	1.78	1.54	1.84	1.17	1.31	1.48	1.65	1.31	1.56	ns
DIFF_HSTL_II_S	0.63	0.67	0.77	0.84	0.67	0.79	1.15	1.24	1.27	1.61	1.24	1.78	0.91	1.01	1.14	1.47	1.01	1.50	ns
DIFF_HSTL_I_18_S	0.65	0.69	0.78	0.84	0.69	0.79	1.27	1.38	1.43	1.45	1.38	1.67	1.03	1.14	1.30	1.32	1.14	1.39	ns
DIFF_HSTL_II_18_S	0.65	0.69	0.78	0.85	0.69	0.81	1.14	1.23	1.26	1.57	1.23	1.72	0.90	1.00	1.13	1.44	1.00	1.44	ns
HSTL_I_F	0.61	0.64	0.73	0.84	0.64	0.79	1.10	1.19	1.23	1.31	1.19	1.41	0.85	0.96	1.10	1.18	0.96	1.13	ns
HSTL_II_F	0.61	0.64	0.73	0.84	0.64	0.78	1.05	1.18	1.28	1.31	1.18	1.42	0.80	0.95	1.15	1.18	0.95	1.14	ns
HSTL_I_18_F	0.64	0.67	0.76	0.85	0.67	0.79	1.05	1.18	1.28	1.36	1.18	1.44	0.80	0.95	1.15	1.22	0.95	1.16	ns
HSTL_II_18_F	0.64	0.67	0.76	0.85	0.67	0.79	1.03	1.14	1.23	1.32	1.14	1.42	0.78	0.90	1.10	1.19	0.90	1.14	ns
DIFF_HSTL_I_F	0.63	0.67	0.77	0.84	0.67	0.78	1.09	1.18	1.22	1.31	1.18	1.48	0.84	0.95	1.09	1.18	0.95	1.20	ns
DIFF_HSTL_II_F	0.63	0.67	0.77	0.84	0.67	0.79	1.02	1.11	1.14	1.31	1.11	1.48	0.77	0.88	1.01	1.18	0.88	1.20	ns
DIFF_HSTL_I_18_F	0.65	0.69	0.78	0.84	0.69	0.79	1.08	1.17	1.21	1.36	1.17	1.48	0.83	0.94	1.07	1.22	0.94	1.20	ns
DIFF_HSTL_II_18_F	0.65	0.69	0.78	0.85	0.69	0.81	1.01	1.10	1.13	1.32	1.10	1.48	0.76	0.87	1.00	1.19	0.87	1.20	ns
LVC MOS33_S4	1.31	1.40	1.60	1.60	1.40	1.54	3.77	3.90	4.00	4.00	3.90	4.13	3.52	3.67	3.86	3.86	3.67	3.85	ns
LVC MOS33_S8	1.31	1.40	1.60	1.60	1.40	1.54	3.49	3.62	3.72	3.72	3.62	3.84	3.24	3.39	3.58	3.58	3.39	3.56	ns
LVC MOS33_S12	1.31	1.40	1.60	1.60	1.40	1.54	3.05	3.18	3.28	3.28	3.18	3.41	2.80	2.95	3.15	3.15	2.95	3.13	ns
LVC MOS33_S16	1.31	1.40	1.60	1.60	1.40	1.54	3.06	3.43	3.88	3.88	3.43	3.72	2.81	3.20	3.75	3.75	3.20	3.44	ns
LVC MOS33_F4	1.31	1.40	1.60	1.60	1.40	1.54	3.22	3.36	3.45	3.45	3.36	3.58	2.98	3.12	3.32	3.32	3.12	3.30	ns
LVC MOS33_F8	1.31	1.40	1.60	1.60	1.40	1.54	2.71	2.84	2.93	2.93	2.84	3.06	2.46	2.61	2.80	2.80	2.61	2.78	ns
LVC MOS33_F12	1.31	1.40	1.60	1.60	1.40	1.54	2.57	2.85	3.15	3.15	2.85	2.88	2.33	2.61	3.02	3.02	2.61	2.60	ns
LVC MOS33_F16	1.31	1.40	1.60	1.60	1.40	1.54	2.44	2.69	2.96	2.96	2.69	2.88	2.19	2.45	2.82	2.82	2.45	2.60	ns
LVC MOS25_S4	1.08	1.16	1.32	1.35	1.16	1.36	3.08	3.22	3.31	3.31	3.22	3.44	2.84	2.98	3.18	3.18	2.98	3.16	ns
LVC MOS25_S8	1.08	1.16	1.32	1.35	1.16	1.36	2.85	2.98	3.07	3.08	2.98	3.20	2.60	2.75	2.94	2.94	2.75	2.92	ns
LVC MOS25_S12	1.08	1.16	1.32	1.35	1.16	1.36	2.44	2.57	2.67	2.67	2.57	2.80	2.19	2.34	2.54	2.54	2.34	2.52	ns
LVC MOS25_S16	1.08	1.16	1.32	1.35	1.16	1.36	2.79	2.92	3.01	3.01	2.92	3.14	2.54	2.68	2.88	2.88	2.68	2.86	ns
LVC MOS25_F4	1.08	1.16	1.32	1.35	1.16	1.36	2.71	2.84	2.93	2.93	2.84	3.06	2.46	2.61	2.80	2.80	2.61	2.78	ns
LVC MOS25_F8	1.08	1.16	1.32	1.35	1.16	1.36	2.14	2.28	2.37	2.37	2.28	2.50	1.90	2.04	2.24	2.24	2.04	2.22	ns
LVC MOS25_F12	1.08	1.16	1.32	1.35	1.16	1.36	2.15	2.29	2.52	2.52	2.29	2.48	1.91	2.05	2.38	2.38	2.05	2.20	ns
LVC MOS25_F16	1.08	1.16	1.32	1.35	1.16	1.36	1.92	2.17	2.45	2.45	2.17	2.33	1.67	1.94	2.32	2.32	1.94	2.05	ns
LVC MOS18_S4	0.64	0.66	0.74	0.95	0.66	0.87	1.55	1.68	1.78	1.78	1.68	1.91	1.30	1.45	1.65	1.65	1.45	1.63	ns
LVC MOS18_S8	0.64	0.66	0.74	0.95	0.66	0.87	2.14	2.28	2.37	2.37	2.28	2.50	1.90	2.04	2.24	2.24	2.04	2.22	ns

Table 20: IOB High Range (HR) Switching Characteristics (Cont'd)

I/O Standard	T _{IOPI}						T _{IOOP}						T _{IOTP}						Units
	Speed Grade						Speed Grade						Speed Grade						
	1.0V			0.95V	0.9V	1.0V			0.95V	0.9V	1.0V			0.95V	0.9V				
	-3	-2/ -2LE	-1	-1M/ -1LM/ -1Q	-2LI	-2LE	-3	-2/ -2LE	-1	-1M/ -1LM/ -1Q	-2LI	-2LE	-3	-2/ -2LE	-1	-1M/ -1LM/ -1Q	-2LI	-2LE	
LVC MOS18_S12	0.64	0.66	0.74	0.95	0.66	0.87	2.14	2.28	2.37	2.37	2.28	2.50	1.90	2.04	2.24	2.24	2.04	2.22	ns
LVC MOS18_S16	0.64	0.66	0.74	0.95	0.66	0.87	1.49	1.62	1.72	1.72	1.62	1.84	1.24	1.39	1.58	1.58	1.39	1.56	ns
LVC MOS18_S24	0.64	0.66	0.74	0.95	0.66	0.87	1.74	1.92	2.08	2.22	1.92	1.92	1.50	1.69	1.95	2.08	1.69	1.64	ns
LVC MOS18_F4	0.64	0.66	0.74	0.95	0.66	0.87	1.38	1.51	1.61	1.64	1.51	1.77	1.13	1.28	1.47	1.50	1.28	1.49	ns
LVC MOS18_F8	0.64	0.66	0.74	0.95	0.66	0.87	1.64	1.78	1.87	1.87	1.78	2.00	1.40	1.54	1.74	1.74	1.54	1.72	ns
LVC MOS18_F12	0.64	0.66	0.74	0.95	0.66	0.87	1.64	1.78	1.87	1.87	1.78	2.00	1.40	1.54	1.74	1.74	1.54	1.72	ns
LVC MOS18_F16	0.64	0.66	0.74	0.95	0.66	0.87	1.52	1.68	1.81	1.81	1.68	1.72	1.28	1.45	1.68	1.68	1.45	1.44	ns
LVC MOS18_F24	0.64	0.66	0.74	0.95	0.66	0.87	1.34	1.46	1.55	2.09	1.46	1.66	1.09	1.23	1.42	1.96	1.23	1.38	ns
LVC MOS15_S4	0.66	0.69	0.81	0.93	0.69	0.90	1.86	2.00	2.09	2.09	2.00	2.22	1.62	1.76	1.96	1.96	1.76	1.94	ns
LVC MOS15_S8	0.66	0.69	0.81	0.93	0.69	0.90	2.05	2.18	2.28	2.28	2.18	2.41	1.80	1.95	2.14	2.15	1.95	2.13	ns
LVC MOS15_S12	0.66	0.69	0.81	0.93	0.69	0.90	1.83	2.03	2.23	2.23	2.03	1.91	1.59	1.80	2.10	2.10	1.80	1.63	ns
LVC MOS15_S16	0.66	0.69	0.81	0.93	0.69	0.90	1.76	1.95	2.13	2.13	1.95	1.91	1.52	1.72	1.99	1.99	1.72	1.63	ns
LVC MOS15_F4	0.66	0.69	0.81	0.93	0.69	0.90	1.63	1.76	1.86	1.86	1.76	1.98	1.38	1.53	1.72	1.72	1.53	1.70	ns
LVC MOS15_F8	0.66	0.69	0.81	0.93	0.69	0.90	1.79	1.99	2.18	2.18	1.99	1.92	1.55	1.76	2.05	2.05	1.76	1.64	ns
LVC MOS15_F12	0.66	0.69	0.81	0.93	0.69	0.90	1.40	1.54	1.65	1.65	1.54	1.67	1.15	1.31	1.52	1.52	1.31	1.39	ns
LVC MOS15_F16	0.66	0.69	0.81	0.93	0.69	0.90	1.37	1.51	1.61	1.89	1.51	1.66	1.13	1.27	1.48	1.75	1.27	1.38	ns
LVC MOS12_S4	0.88	0.91	1.00	1.17	0.91	1.01	2.53	2.67	2.76	2.76	2.67	2.89	2.29	2.43	2.63	2.63	2.43	2.61	ns
LVC MOS12_S8	0.88	0.91	1.00	1.17	0.91	1.01	2.05	2.18	2.28	2.28	2.18	2.41	1.80	1.95	2.14	2.15	1.95	2.13	ns
LVC MOS12_S12	0.88	0.91	1.00	1.17	0.91	1.01	1.75	1.89	1.98	1.98	1.89	2.11	1.51	1.65	1.85	1.85	1.65	1.83	ns
LVC MOS12_F4	0.88	0.91	1.00	1.17	0.91	1.01	1.94	2.07	2.17	2.17	2.07	2.30	1.69	1.84	2.04	2.04	1.84	2.02	ns
LVC MOS12_F8	0.88	0.91	1.00	1.17	0.91	1.01	1.50	1.64	1.73	1.73	1.64	1.86	1.26	1.40	1.60	1.60	1.40	1.58	ns
LVC MOS12_F12	0.88	0.91	1.00	1.17	0.91	1.01	1.54	1.71	1.87	1.87	1.71	1.69	1.29	1.48	1.74	1.74	1.48	1.41	ns
SSTL135_S	0.61	0.64	0.73	0.85	0.64	0.79	1.27	1.40	1.50	1.53	1.40	1.64	1.02	1.17	1.36	1.40	1.17	1.36	ns
SSTL15_S	0.61	0.64	0.73	0.73	0.64	0.73	1.24	1.37	1.47	1.53	1.37	1.59	0.99	1.14	1.33	1.40	1.14	1.31	ns
SSTL18_I_S	0.64	0.67	0.76	0.84	0.67	0.79	1.59	1.74	1.85	1.85	1.74	1.95	1.34	1.50	1.72	1.72	1.50	1.67	ns
SSTL18_II_S	0.64	0.67	0.76	0.85	0.67	0.78	1.27	1.40	1.50	1.50	1.40	1.63	1.02	1.17	1.36	1.36	1.17	1.35	ns
DIFF_SSTL135_S	0.59	0.61	0.73	0.85	0.61	0.79	1.27	1.40	1.50	1.53	1.40	1.64	1.02	1.17	1.36	1.40	1.17	1.36	ns
DIFF_SSTL15_S	0.63	0.67	0.77	0.85	0.67	0.79	1.24	1.37	1.47	1.53	1.37	1.59	0.99	1.14	1.33	1.40	1.14	1.31	ns
DIFF_SSTL18_I_S	0.65	0.69	0.78	0.85	0.69	0.79	1.50	1.63	1.72	1.82	1.63	1.95	1.26	1.40	1.59	1.69	1.40	1.67	ns
DIFF_SSTL18_II_S	0.65	0.69	0.78	0.85	0.69	0.79	1.13	1.22	1.25	1.50	1.22	1.66	0.88	0.99	1.12	1.36	0.99	1.38	ns

Table 20: IOB High Range (HR) Switching Characteristics (Cont'd)

I/O Standard	T _{IOPI}						T _{IOOP}						T _{IOTP}						Units
	Speed Grade						Speed Grade						Speed Grade						
	1.0V			0.95V	0.9V	1.0V			0.95V	0.9V	1.0V			0.95V	0.9V				
	-3	-2/ -2LE	-1	-1M/ -1LM/ -1Q	-2LI	-2LE	-3	-2/ -2LE	-1	-1M/ -1LM/ -1Q	-2LI	-2LE	-3	-2/ -2LE	-1	-1M/ -1LM/ -1Q	-2LI	-2LE	
SSTL135_F	0.61	0.64	0.73	0.85	0.64	0.79	1.04	1.17	1.26	1.31	1.17	1.42	0.79	0.93	1.13	1.18	0.93	1.14	ns
SSTL15_F	0.61	0.64	0.73	0.73	0.64	0.73	1.04	1.17	1.26	1.26	1.17	1.39	0.79	0.93	1.13	1.13	0.93	1.11	ns
SSTL18_I_F	0.64	0.67	0.76	0.84	0.67	0.79	1.12	1.22	1.26	1.34	1.22	1.44	0.88	0.99	1.13	1.21	0.99	1.16	ns
SSTL18_II_F	0.64	0.67	0.76	0.85	0.67	0.78	1.05	1.18	1.28	1.32	1.18	1.42	0.80	0.95	1.15	1.19	0.95	1.14	ns
DIFF_SSTL135_F	0.59	0.61	0.73	0.85	0.61	0.79	1.04	1.17	1.26	1.31	1.17	1.42	0.79	0.93	1.13	1.18	0.93	1.14	ns
DIFF_SSTL15_F	0.63	0.67	0.77	0.85	0.67	0.79	1.04	1.17	1.26	1.26	1.17	1.39	0.79	0.93	1.13	1.13	0.93	1.11	ns
DIFF_SSTL18_I_F	0.65	0.69	0.78	0.85	0.69	0.79	1.10	1.19	1.23	1.34	1.19	1.52	0.85	0.96	1.10	1.21	0.96	1.24	ns
DIFF_SSTL18_II_F	0.65	0.69	0.78	0.85	0.69	0.79	1.02	1.10	1.14	1.32	1.10	1.50	0.77	0.87	1.00	1.19	0.87	1.22	ns

Table 21: IOB High Performance (HP) Switching Characteristics

I/O Standard	T _{IOPI}						T _{IOOP}						T _{IOTP}						Units
	Speed Grade						Speed Grade						Speed Grade						
	1.0V			0.95V	0.9V	1.0V			0.95V	0.9V	1.0V			0.95V	0.9V				
	-3	-2/ -2LE	-1	-1M/ -1LM/ -1Q	-2LI	-2LE	-3	-2/ -2LE	-1	-1M/ -1LM/ -1Q	-2LI	-2LE	-3	-2/ -2LE	-1	-1M/ -1LM/ -1Q	-2LI	-2LE	
LVDS	0.75	0.79	0.92	0.96	0.79	0.89	1.05	1.17	1.24	1.26	1.17	1.43	0.88	1.01	1.08	1.10	1.01	1.32	ns
HSUL_12_S	0.69	0.72	0.82	0.98	0.72	0.95	1.65	1.84	2.05	2.05	1.84	1.80	1.48	1.68	1.89	1.89	1.68	1.70	ns
HSUL_12_F	0.69	0.72	0.82	0.98	0.72	0.95	1.39	1.54	1.68	1.68	1.54	1.49	1.22	1.38	1.52	1.52	1.38	1.39	ns
DIFF_HSUL_12_S	0.69	0.72	0.82	0.98	0.72	0.92	1.65	1.84	2.05	2.05	1.84	1.47	1.48	1.68	1.89	1.89	1.68	1.37	ns
DIFF_HSUL_12_F	0.69	0.72	0.82	0.98	0.72	0.92	1.39	1.54	1.68	1.68	1.54	1.35	1.22	1.38	1.52	1.52	1.38	1.24	ns
DIFF_HSUL_12_DCI_S	0.69	0.72	0.82	0.82	0.72	0.92	1.78	1.91	2.05	2.05	1.91	1.46	1.61	1.76	1.89	1.89	1.76	1.35	ns
DIFF_HSUL_12_DCI_F	0.69	0.72	0.82	0.82	0.72	0.92	1.56	1.67	1.76	1.76	1.67	1.35	1.39	1.51	1.60	1.60	1.51	1.24	ns
HSTL_I_S	0.68	0.72	0.82	0.90	0.72	0.84	1.15	1.28	1.38	1.38	1.28	1.46	0.98	1.12	1.22	1.22	1.12	1.35	ns
HSTL_II_S	0.68	0.72	0.82	0.90	0.72	0.84	1.05	1.17	1.26	1.27	1.17	1.44	0.88	1.01	1.10	1.11	1.01	1.34	ns
HSTL_I_18_S	0.70	0.72	0.82	0.95	0.72	0.86	1.12	1.24	1.34	1.34	1.24	1.41	0.95	1.08	1.18	1.18	1.08	1.31	ns
HSTL_II_18_S	0.70	0.72	0.82	0.90	0.72	0.86	1.06	1.18	1.26	1.27	1.18	1.44	0.89	1.02	1.10	1.11	1.02	1.34	ns
HSTL_I_12_S	0.68	0.72	0.82	0.96	0.72	0.94	1.14	1.27	1.37	1.37	1.27	1.43	0.97	1.11	1.21	1.21	1.11	1.32	ns
HSTL_I_DCI_S	0.68	0.72	0.82	0.90	0.72	0.78	1.11	1.23	1.33	1.33	1.23	1.36	0.94	1.07	1.17	1.17	1.07	1.26	ns
HSTL_II_DCI_S	0.68	0.72	0.82	0.85	0.72	0.78	1.05	1.17	1.26	1.26	1.17	1.33	0.88	1.01	1.10	1.10	1.01	1.23	ns
HSTL_I_DCI_18_S	0.70	0.72	0.82	0.90	0.72	0.76	1.11	1.23	1.33	1.33	1.23	1.36	0.94	1.07	1.17	1.17	1.07	1.26	ns
HSTL_II_DCI_18_S	0.70	0.72	0.82	0.82	0.72	0.76	1.05	1.16	1.24	1.24	1.16	1.32	0.88	1.00	1.08	1.08	1.00	1.21	ns
HSTL_II_T_DCI_18_S	0.70	0.72	0.82	0.84	0.72	0.76	1.11	1.23	1.33	1.34	1.23	1.36	0.94	1.07	1.17	1.18	1.07	1.26	ns
DIFF_HSTL_I_S	0.75	0.79	0.92	1.02	0.79	0.89	1.15	1.28	1.38	1.38	1.28	1.47	0.98	1.12	1.22	1.22	1.12	1.37	ns
DIFF_HSTL_II_S	0.75	0.79	0.92	1.02	0.79	0.89	1.05	1.17	1.26	1.32	1.17	1.47	0.88	1.01	1.10	1.16	1.01	1.37	ns
DIFF_HSTL_I_DCI_S	0.75	0.79	0.92	0.92	0.79	0.76	1.15	1.28	1.38	1.38	1.28	1.47	0.98	1.12	1.22	1.22	1.12	1.37	ns
DIFF_HSTL_II_DCI_S	0.75	0.79	0.92	0.92	0.79	0.76	1.05	1.17	1.26	1.26	1.17	1.40	0.88	1.01	1.10	1.10	1.01	1.29	ns
DIFF_HSTL_I_18_S	0.75	0.79	0.92	0.98	0.79	0.89	1.12	1.24	1.34	1.34	1.24	1.46	0.95	1.08	1.18	1.18	1.08	1.35	ns
DIFF_HSTL_II_18_S	0.75	0.79	0.92	0.99	0.79	0.89	1.06	1.18	1.26	1.32	1.18	1.47	0.89	1.02	1.10	1.16	1.02	1.37	ns
DIFF_HSTL_I_DCI_18_S	0.75	0.79	0.92	0.92	0.79	0.75	1.11	1.23	1.33	1.33	1.23	1.46	0.94	1.07	1.17	1.17	1.07	1.35	ns
DIFF_HSTL_II_DCI_18_S	0.75	0.79	0.92	0.93	0.79	0.75	1.05	1.16	1.24	1.26	1.16	1.41	0.88	1.00	1.08	1.10	1.00	1.31	ns
DIFF_HSTL_II_T_DCI_18_S	0.75	0.79	0.92	0.92	0.79	0.76	1.11	1.23	1.33	1.33	1.23	1.46	0.94	1.07	1.17	1.17	1.07	1.35	ns
HSTL_I_F	0.68	0.72	0.82	0.90	0.72	0.84	1.02	1.14	1.22	1.22	1.14	1.26	0.85	0.98	1.06	1.06	0.98	1.15	ns
HSTL_II_F	0.68	0.72	0.82	0.90	0.72	0.84	0.97	1.08	1.15	1.15	1.08	1.29	0.80	0.92	0.99	0.99	0.92	1.18	ns
HSTL_I_18_F	0.70	0.72	0.82	0.95	0.72	0.86	1.04	1.16	1.24	1.24	1.16	1.32	0.87	1.00	1.08	1.08	1.00	1.21	ns

Table 21: IOB High Performance (HP) Switching Characteristics (Cont'd)

I/O Standard	T _{IOPI}						T _{IOOP}						T _{IOTP}						Units
	Speed Grade						Speed Grade						Speed Grade						
	1.0V			0.95V	0.9V	1.0V			0.95V	0.9V	1.0V			0.95V	0.9V				
	-3	-2/ -2LE	-1	-1M/ -1LM/ -1Q	-2LI	-2LE	-3	-2/ -2LE	-1	-1M/ -1LM/ -1Q	-2LI	-2LE	-3	-2/ -2LE	-1	-1M/ -1LM/ -1Q	-2LI	-2LE	
HSTL_II_18_F	0.70	0.72	0.82	0.90	0.72	0.86	0.98	1.09	1.16	1.20	1.09	1.35	0.81	0.94	1.00	1.03	0.94	1.24	ns
HSTL_I_12_F	0.68	0.72	0.82	0.96	0.72	0.94	1.02	1.13	1.21	1.21	1.13	1.26	0.85	0.97	1.05	1.05	0.97	1.15	ns
HSTL_I_DCI_F	0.68	0.72	0.82	0.90	0.72	0.78	1.04	1.16	1.24	1.24	1.16	1.30	0.87	1.00	1.08	1.08	1.00	1.20	ns
HSTL_II_DCI_F	0.68	0.72	0.82	0.85	0.72	0.78	0.97	1.08	1.15	1.15	1.08	1.22	0.80	0.92	0.99	0.99	0.92	1.12	ns
HSTL_II_T_DCI_F	0.70	0.72	0.82	0.82	0.72	0.76	1.02	1.14	1.22	1.22	1.14	1.26	0.85	0.98	1.06	1.06	0.98	1.15	ns
HSTL_I_DCI_18_F	0.70	0.72	0.82	0.90	0.72	0.76	1.04	1.16	1.24	1.24	1.16	1.30	0.87	1.00	1.08	1.08	1.00	1.20	ns
HSTL_II_DCI_18_F	0.70	0.72	0.82	0.82	0.72	0.76	0.98	1.09	1.16	1.16	1.09	1.27	0.81	0.93	1.00	1.00	0.93	1.17	ns
HSTL_II_T_DCI_18_F	0.70	0.72	0.82	0.84	0.72	0.76	1.04	1.16	1.24	1.24	1.16	1.30	0.87	1.00	1.08	1.08	1.00	1.20	ns
DIFF_HSTL_I_F	0.75	0.79	0.92	1.02	0.79	0.89	1.02	1.14	1.22	1.22	1.14	1.35	0.85	0.98	1.06	1.06	0.98	1.24	ns
DIFF_HSTL_II_F	0.75	0.79	0.92	1.02	0.79	0.89	0.97	1.08	1.15	1.20	1.08	1.35	0.80	0.92	0.99	1.03	0.92	1.24	ns
DIFF_HSTL_I_DCI_F	0.75	0.79	0.92	0.92	0.79	0.76	1.02	1.14	1.22	1.22	1.14	1.35	0.85	0.98	1.06	1.06	0.98	1.24	ns
DIFF_HSTL_II_DCI_F	0.75	0.79	0.92	0.92	0.79	0.76	0.97	1.08	1.15	1.15	1.08	1.30	0.80	0.92	0.99	0.99	0.92	1.20	ns
DIFF_HSTL_I_18_F	0.75	0.79	0.92	0.98	0.79	0.89	1.04	1.16	1.24	1.24	1.16	1.38	0.87	1.00	1.08	1.08	1.00	1.28	ns
DIFF_HSTL_II_18_F	0.75	0.79	0.92	0.99	0.79	0.89	0.98	1.09	1.16	1.24	1.09	1.40	0.81	0.94	1.00	1.08	0.94	1.29	ns
DIFF_HSTL_I_DCI_18_F	0.75	0.79	0.92	0.92	0.79	0.75	1.04	1.16	1.24	1.24	1.16	1.38	0.87	1.00	1.08	1.08	1.00	1.28	ns
DIFF_HSTL_II_DCI_18_F	0.75	0.79	0.92	0.93	0.79	0.75	0.98	1.09	1.16	1.18	1.09	1.33	0.81	0.93	1.00	1.02	0.93	1.23	ns
DIFF_HSTL_II_T_DCI_18_F	0.75	0.79	0.92	0.92	0.79	0.76	1.04	1.16	1.24	1.24	1.16	1.38	0.87	1.00	1.08	1.08	1.00	1.28	ns
LVC MOS18_S2	0.47	0.50	0.60	0.90	0.50	0.87	3.95	4.28	4.85	4.85	4.28	3.40	3.78	4.13	4.69	4.69	4.13	3.29	ns
LVC MOS18_S4	0.47	0.50	0.60	0.90	0.50	0.87	2.67	2.98	3.43	3.43	2.98	2.69	2.50	2.82	3.27	3.27	2.82	2.59	ns
LVC MOS18_S6	0.47	0.50	0.60	0.90	0.50	0.87	2.14	2.38	2.72	2.72	2.38	2.18	1.97	2.22	2.56	2.56	2.22	2.07	ns
LVC MOS18_S8	0.47	0.50	0.60	0.90	0.50	0.87	1.98	2.21	2.52	2.52	2.21	2.02	1.81	2.05	2.36	2.36	2.05	1.92	ns
LVC MOS18_S12	0.47	0.50	0.60	0.90	0.50	0.87	1.70	1.91	2.17	2.17	1.91	1.85	1.53	1.75	2.01	2.01	1.75	1.74	ns
LVC MOS18_S16	0.47	0.50	0.60	0.90	0.50	0.87	1.57	1.75	1.97	1.97	1.75	1.76	1.40	1.59	1.81	1.81	1.59	1.65	ns
LVC MOS18_F2	0.47	0.50	0.60	0.90	0.50	0.87	3.50	3.87	4.48	4.48	3.87	2.85	3.33	3.71	4.32	4.32	3.71	2.74	ns
LVC MOS18_F4	0.47	0.50	0.60	0.90	0.50	0.87	2.23	2.50	2.87	2.87	2.50	2.26	2.06	2.34	2.71	2.71	2.34	2.15	ns
LVC MOS18_F6	0.47	0.50	0.60	0.90	0.50	0.87	1.80	2.00	2.26	2.26	2.00	1.52	1.63	1.84	2.09	2.09	1.84	1.42	ns
LVC MOS18_F8	0.47	0.50	0.60	0.90	0.50	0.87	1.46	1.72	2.04	2.04	1.72	1.51	1.29	1.56	1.88	1.88	1.56	1.40	ns
LVC MOS18_F12	0.47	0.50	0.60	0.90	0.50	0.87	1.26	1.40	1.53	1.53	1.40	1.46	1.09	1.24	1.37	1.37	1.24	1.35	ns
LVC MOS18_F16	0.47	0.50	0.60	0.90	0.50	0.87	1.19	1.33	1.44	1.66	1.33	1.46	1.02	1.17	1.28	1.50	1.17	1.35	ns
LVC MOS15_S2	0.59	0.62	0.73	0.88	0.62	0.86	3.55	3.89	4.45	4.45	3.89	3.11	3.38	3.73	4.29	4.29	3.73	3.01	ns
LVC MOS15_S4	0.59	0.62	0.73	0.88	0.62	0.86	2.45	2.70	3.06	3.06	2.70	2.46	2.28	2.54	2.90	2.90	2.54	2.35	ns
LVC MOS15_S6	0.59	0.62	0.73	0.88	0.62	0.86	2.24	2.51	2.88	2.88	2.51	2.33	2.07	2.35	2.72	2.72	2.35	2.23	ns

Table 21: IOB High Performance (HP) Switching Characteristics (Cont'd)

I/O Standard	T _{IOPI}						T _{IOOP}						T _{IOTP}						Units
	Speed Grade						Speed Grade						Speed Grade						
	1.0V			0.95V	0.9V	1.0V			0.95V	0.9V	1.0V			0.95V	0.9V				
	-3	-2/ -2LE	-1	-1M/ -1LM/ -1Q	-2LI	-2LE	-3	-2/ -2LE	-1	-1M/ -1LM/ -1Q	-2LI	-2LE	-3	-2/ -2LE	-1	-1M/ -1LM/ -1Q	-2LI	-2LE	
LVC MOS15_S8	0.59	0.62	0.73	0.88	0.62	0.86	1.91	2.16	2.49	2.49	2.16	2.05	1.74	2.00	2.32	2.32	2.00	1.95	ns
LVC MOS15_S12	0.59	0.62	0.73	0.88	0.62	0.86	1.77	1.98	2.23	2.23	1.98	1.97	1.60	1.82	2.07	2.07	1.82	1.87	ns
LVC MOS15_S16	0.59	0.62	0.73	0.88	0.62	0.86	1.62	1.81	2.02	2.02	1.81	1.85	1.45	1.65	1.86	1.86	1.65	1.74	ns
LVC MOS15_F2	0.59	0.62	0.73	0.88	0.62	0.86	3.38	3.69	4.18	4.18	3.69	2.74	3.21	3.53	4.02	4.02	3.53	2.64	ns
LVC MOS15_F4	0.59	0.62	0.73	0.88	0.62	0.86	2.04	2.21	2.44	2.44	2.21	1.72	1.87	2.06	2.27	2.27	2.06	1.62	ns
LVC MOS15_F6	0.59	0.62	0.73	0.88	0.62	0.86	1.47	1.74	2.09	2.09	1.74	1.49	1.30	1.58	1.93	1.93	1.58	1.39	ns
LVC MOS15_F8	0.59	0.62	0.73	0.88	0.62	0.86	1.31	1.46	1.61	1.61	1.46	1.47	1.14	1.30	1.45	1.45	1.30	1.37	ns
LVC MOS15_F12	0.59	0.62	0.73	0.88	0.62	0.86	1.21	1.34	1.45	1.45	1.34	1.44	1.04	1.18	1.29	1.29	1.18	1.34	ns
LVC MOS15_F16	0.59	0.62	0.73	0.88	0.62	0.86	1.18	1.31	1.41	1.68	1.31	1.41	1.01	1.15	1.25	1.52	1.15	1.31	ns
LVC MOS12_S2	0.64	0.67	0.78	1.04	0.67	0.95	3.38	3.80	4.48	4.48	3.80	3.27	3.21	3.64	4.31	4.31	3.64	3.17	ns
LVC MOS12_S4	0.64	0.67	0.78	1.04	0.67	0.95	2.62	2.94	3.43	3.43	2.94	2.76	2.45	2.78	3.27	3.27	2.78	2.65	ns
LVC MOS12_S6	0.64	0.67	0.78	1.04	0.67	0.95	2.05	2.33	2.72	2.72	2.33	2.24	1.88	2.17	2.56	2.56	2.17	2.14	ns
LVC MOS12_S8	0.64	0.67	0.78	1.04	0.67	0.95	1.94	2.18	2.51	2.51	2.18	2.16	1.77	2.02	2.34	2.34	2.02	2.06	ns
LVC MOS12_F2	0.64	0.67	0.78	1.04	0.67	0.95	2.84	3.15	3.62	3.62	3.15	2.47	2.67	2.99	3.46	3.46	2.99	2.37	ns
LVC MOS12_F4	0.64	0.67	0.78	1.04	0.67	0.95	1.97	2.18	2.44	2.44	2.18	1.69	1.80	2.02	2.28	2.28	2.02	1.59	ns
LVC MOS12_F6	0.64	0.67	0.78	1.04	0.67	0.95	1.33	1.51	1.70	1.70	1.51	1.43	1.16	1.35	1.54	1.54	1.35	1.32	ns
LVC MOS12_F8	0.64	0.67	0.78	1.04	0.67	0.95	1.27	1.42	1.55	1.55	1.42	1.41	1.10	1.26	1.39	1.39	1.26	1.31	ns
LVDCI_18	0.47	0.50	0.60	0.87	0.50	0.86	1.99	2.15	2.35	2.35	2.15	2.44	1.82	1.99	2.19	2.19	1.99	2.34	ns
LVDCI_15	0.59	0.62	0.73	0.92	0.62	0.87	1.98	2.23	2.58	2.58	2.23	2.40	1.81	2.07	2.41	2.41	2.07	2.29	ns
LVDCI_DV2_18	0.47	0.50	0.60	0.88	0.50	0.87	1.99	2.15	2.34	2.34	2.15	1.86	1.82	1.99	2.18	2.18	1.99	1.76	ns
LVDCI_DV2_15	0.59	0.62	0.73	0.88	0.62	0.87	1.98	2.23	2.58	2.58	2.23	1.83	1.81	2.07	2.41	2.41	2.07	1.73	ns
HSLVDCI_18	0.68	0.72	0.82	0.90	0.72	0.86	1.99	2.15	2.35	2.35	2.15	2.43	1.82	1.99	2.19	2.19	1.99	2.32	ns
HSLVDCI_15	0.68	0.72	0.82	0.93	0.72	0.84	1.98	2.23	2.58	2.58	2.23	2.27	1.81	2.07	2.41	2.41	2.07	2.17	ns
SSTL18_I_S	0.68	0.72	0.82	0.95	0.72	0.86	1.02	1.15	1.24	1.24	1.15	1.41	0.85	0.99	1.08	1.08	0.99	1.31	ns
SSTL18_II_S	0.68	0.72	0.82	1.01	0.72	0.87	1.17	1.29	1.37	1.38	1.29	1.55	1.00	1.13	1.21	1.22	1.13	1.45	ns
SSTL18_I_DCI_S	0.68	0.72	0.82	0.87	0.72	0.76	0.92	1.06	1.17	1.18	1.06	1.32	0.75	0.90	1.01	1.02	0.90	1.21	ns
SSTL18_II_DCI_S	0.68	0.72	0.82	0.82	0.72	0.78	0.88	0.98	1.08	1.12	0.98	1.26	0.71	0.83	0.92	0.96	0.83	1.15	ns
SSTL18_II_T_DCI_S	0.68	0.72	0.82	0.98	0.72	0.78	0.92	1.06	1.17	1.18	1.06	1.32	0.75	0.90	1.01	1.02	0.90	1.21	ns
SSTL15_S	0.68	0.72	0.82	0.82	0.72	0.81	0.94	1.06	1.15	1.16	1.06	1.32	0.77	0.91	0.99	1.00	0.91	1.21	ns
SSTL15_DCI_S	0.68	0.72	0.82	0.90	0.72	0.78	0.94	1.06	1.15	1.16	1.06	1.30	0.77	0.90	0.99	1.00	0.90	1.20	ns
SSTL15_T_DCI_S	0.68	0.72	0.82	0.87	0.72	0.80	0.94	1.06	1.15	1.15	1.06	1.30	0.77	0.90	0.99	0.99	0.90	1.20	ns
SSTL135_S	0.69	0.72	0.82	0.93	0.72	0.89	0.97	1.10	1.19	1.20	1.10	1.35	0.80	0.94	1.03	1.03	0.94	1.24	ns
SSTL135_DCI_S	0.69	0.72	0.82	0.85	0.72	0.84	0.97	1.09	1.19	1.20	1.09	1.33	0.80	0.93	1.03	1.03	0.93	1.23	ns
SSTL135_T_DCI_S	0.69	0.72	0.82	0.93	0.72	0.84	0.97	1.09	1.19	1.20	1.09	1.33	0.80	0.93	1.03	1.03	0.93	1.23	ns
SSTL12_S	0.69	0.72	0.82	1.02	0.72	0.95	0.96	1.09	1.18	1.18	1.09	1.33	0.79	0.93	1.02	1.02	0.93	1.23	ns
SSTL12_DCI_S	0.69	0.72	0.82	0.90	0.72	0.91	1.03	1.17	1.27	1.27	1.17	1.33	0.86	1.01	1.11	1.11	1.01	1.23	ns

Table 21: IOB High Performance (HP) Switching Characteristics (Cont'd)

I/O Standard	T _{IOPI}						T _{IOOP}						T _{IOTP}						Units
	Speed Grade						Speed Grade						Speed Grade						
	1.0V			0.95V	0.9V	1.0V			0.95V	0.9V	1.0V			0.95V	0.9V				
	-3	-2/ -2LE	-1	-1M/ -1LM/ -1Q	-2LI	-2LE	-3	-2/ -2LE	-1	-1M/ -1LM/ -1Q	-2LI	-2LE	-3	-2/ -2LE	-1	-1M/ -1LM/ -1Q	-2LI	-2LE	
SSTL12_T_DCI_S	0.69	0.72	0.82	0.88	0.72	0.91	1.03	1.17	1.27	1.27	1.17	1.33	0.86	1.01	1.11	1.11	1.01	1.23	ns
DIFF_SSTL18_I_S	0.75	0.79	0.92	0.99	0.79	0.89	1.02	1.15	1.24	1.29	1.15	1.43	0.85	0.99	1.08	1.13	0.99	1.32	ns
DIFF_SSTL18_IL_S	0.75	0.79	0.92	0.93	0.79	0.89	1.17	1.29	1.37	1.40	1.29	1.55	1.00	1.13	1.21	1.24	1.13	1.45	ns
DIFF_SSTL18_I_DCI_S	0.75	0.79	0.92	0.92	0.79	0.76	0.92	1.06	1.17	1.24	1.06	1.40	0.75	0.90	1.01	1.08	0.90	1.29	ns
DIFF_SSTL18_IL_DCI_S	0.75	0.79	0.92	0.96	0.79	0.75	0.88	0.98	1.08	1.18	0.98	1.33	0.71	0.83	0.92	1.02	0.83	1.23	ns
DIFF_SSTL18_IL_T_DCI_S	0.75	0.79	0.92	0.92	0.79	0.76	0.92	1.06	1.17	1.24	1.06	1.40	0.75	0.90	1.01	1.08	0.90	1.29	ns
DIFF_SSTL15_S	0.68	0.72	0.82	0.99	0.72	0.89	0.94	1.06	1.15	1.16	1.06	1.32	0.77	0.91	0.99	1.00	0.91	1.21	ns
DIFF_SSTL15_DCI_S	0.68	0.72	0.82	0.96	0.72	0.75	0.94	1.06	1.15	1.16	1.06	1.30	0.77	0.90	0.99	1.00	0.90	1.20	ns
DIFF_SSTL15_T_DCI_S	0.68	0.72	0.82	0.88	0.72	0.76	0.94	1.06	1.15	1.23	1.06	1.38	0.77	0.90	0.99	1.07	0.90	1.28	ns
DIFF_SSTL135_S	0.69	0.72	0.82	1.09	0.72	0.91	0.97	1.10	1.19	1.20	1.10	1.35	0.80	0.94	1.03	1.03	0.94	1.24	ns
DIFF_SSTL135_DCI_S	0.69	0.72	0.82	0.90	0.72	0.76	0.97	1.09	1.19	1.20	1.09	1.33	0.80	0.93	1.03	1.03	0.93	1.23	ns
DIFF_SSTL135_T_DCI_S	0.69	0.72	0.82	0.84	0.72	0.76	0.97	1.09	1.19	1.27	1.09	1.43	0.80	0.93	1.03	1.11	0.93	1.32	ns
DIFF_SSTL12_S	0.69	0.72	0.82	0.96	0.72	0.91	0.96	1.09	1.18	1.18	1.09	1.33	0.79	0.93	1.02	1.02	0.93	1.23	ns
DIFF_SSTL12_DCI_S	0.69	0.72	0.82	0.87	0.72	0.78	1.03	1.17	1.27	1.27	1.17	1.33	0.86	1.01	1.11	1.11	1.01	1.23	ns
DIFF_SSTL12_T_DCI_S	0.69	0.72	0.82	0.96	0.72	0.80	1.03	1.17	1.27	1.27	1.17	1.41	0.86	1.01	1.11	1.11	1.01	1.31	ns
SSTL18_I_F	0.68	0.72	0.82	0.95	0.72	0.86	0.94	1.06	1.15	1.15	1.06	1.32	0.77	0.91	0.99	0.99	0.91	1.21	ns
SSTL18_IL_F	0.68	0.72	0.82	1.01	0.72	0.87	0.97	1.09	1.16	1.21	1.09	1.36	0.80	0.93	1.00	1.05	0.93	1.26	ns
SSTL18_I_DCI_F	0.68	0.72	0.82	0.87	0.72	0.76	0.89	1.02	1.10	1.15	1.02	1.30	0.72	0.86	0.94	0.99	0.86	1.20	ns
SSTL18_IL_DCI_F	0.68	0.72	0.82	0.82	0.72	0.78	0.89	1.02	1.10	1.10	1.02	1.24	0.72	0.86	0.94	0.94	0.86	1.14	ns
SSTL18_IL_T_DCI_F	0.68	0.72	0.82	0.98	0.72	0.78	0.89	1.02	1.10	1.15	1.02	1.27	0.72	0.86	0.94	0.99	0.86	1.17	ns
SSTL15_F	0.68	0.72	0.82	0.82	0.72	0.81	0.89	1.01	1.09	1.09	1.01	1.24	0.72	0.85	0.93	0.93	0.85	1.14	ns
SSTL15_DCI_F	0.68	0.72	0.82	0.90	0.72	0.78	0.89	1.01	1.09	1.12	1.01	1.27	0.72	0.85	0.93	0.96	0.85	1.17	ns
SSTL15_T_DCI_F	0.68	0.72	0.82	0.87	0.72	0.80	0.89	1.01	1.09	1.12	1.01	1.27	0.72	0.85	0.93	0.96	0.85	1.17	ns
SSTL135_F	0.69	0.72	0.82	0.93	0.72	0.89	0.88	1.00	1.08	1.12	1.00	1.27	0.71	0.85	0.92	0.96	0.85	1.17	ns
SSTL135_DCI_F	0.69	0.72	0.82	0.85	0.72	0.84	0.89	1.00	1.08	1.12	1.00	1.27	0.72	0.85	0.92	0.96	0.85	1.17	ns
SSTL135_T_DCI_F	0.69	0.72	0.82	0.93	0.72	0.84	0.89	1.00	1.08	1.12	1.00	1.27	0.72	0.85	0.92	0.96	0.85	1.17	ns
SSTL12_F	0.69	0.72	0.82	1.02	0.72	0.95	0.88	1.00	1.08	1.12	1.00	1.26	0.71	0.84	0.92	0.96	0.84	1.15	ns
SSTL12_DCI_F	0.69	0.72	0.82	0.90	0.72	0.91	0.91	1.03	1.11	1.11	1.03	1.24	0.74	0.88	0.95	0.95	0.88	1.14	ns
SSTL12_T_DCI_F	0.69	0.72	0.82	0.88	0.72	0.91	0.91	1.03	1.11	1.12	1.03	1.26	0.74	0.88	0.95	0.96	0.88	1.15	ns

Table 21: IOB High Performance (HP) Switching Characteristics (Cont'd)

I/O Standard	T _{IOP1}						T _{IOP}						T _{IOTP}						Units
	Speed Grade						Speed Grade						Speed Grade						
	1.0V			0.95V	0.9V	1.0V			0.95V	0.9V	1.0V			0.95V	0.9V				
	-3	-2/-2LE	-1	-1M/-1LM/-1Q	-2LI	-2LE	-3	-2/-2LE	-1	-1M/-1LM/-1Q	-2LI	-2LE	-3	-2/-2LE	-1	-1M/-1LM/-1Q	-2LI	-2LE	
DIFF_SSTL18_I_F	0.75	0.79	0.92	0.99	0.79	0.89	0.94	1.06	1.15	1.23	1.06	1.38	0.77	0.91	0.99	1.07	0.91	1.28	ns
DIFF_SSTL18_II_F	0.75	0.79	0.92	0.93	0.79	0.89	0.97	1.09	1.16	1.24	1.09	1.40	0.80	0.93	1.00	1.08	0.93	1.29	ns
DIFF_SSTL18_I_DCI_F	0.75	0.79	0.92	0.92	0.79	0.76	0.89	1.02	1.10	1.23	1.02	1.36	0.72	0.86	0.94	1.07	0.86	1.26	ns
DIFF_SSTL18_II_DCI_F	0.75	0.79	0.92	0.96	0.79	0.75	0.89	1.02	1.10	1.16	1.02	1.32	0.72	0.86	0.94	1.00	0.86	1.21	ns
DIFF_SSTL18_II_T_DCI_F	0.75	0.79	0.92	0.92	0.79	0.76	0.89	1.02	1.10	1.24	1.02	1.38	0.72	0.86	0.94	1.08	0.86	1.28	ns
DIFF_SSTL15_F	0.68	0.72	0.82	0.99	0.72	0.89	0.89	1.01	1.09	1.09	1.01	1.24	0.72	0.85	0.93	0.93	0.85	1.14	ns
DIFF_SSTL15_DCI_F	0.68	0.72	0.82	0.96	0.72	0.75	0.89	1.01	1.09	1.12	1.01	1.27	0.72	0.85	0.93	0.96	0.85	1.17	ns
DIFF_SSTL15_T_DCI_F	0.68	0.72	0.82	0.88	0.72	0.76	0.89	1.01	1.09	1.20	1.01	1.35	0.72	0.85	0.93	1.03	0.85	1.24	ns
DIFF_SSTL135_F	0.69	0.72	0.82	1.09	0.72	0.91	0.88	1.00	1.08	1.12	1.00	1.27	0.71	0.85	0.92	0.96	0.85	1.17	ns
DIFF_SSTL135_DCI_F	0.69	0.72	0.82	0.90	0.72	0.76	0.89	1.00	1.08	1.12	1.00	1.27	0.72	0.85	0.92	0.96	0.85	1.17	ns
DIFF_SSTL135_T_DCI_F	0.69	0.72	0.82	0.84	0.72	0.76	0.89	1.00	1.08	1.20	1.00	1.35	0.72	0.85	0.92	1.03	0.85	1.24	ns
DIFF_SSTL12_F	0.69	0.72	0.82	0.96	0.72	0.91	0.88	1.00	1.08	1.12	1.00	1.26	0.71	0.84	0.92	0.96	0.84	1.15	ns
DIFF_SSTL12_DCI_F	0.69	0.72	0.82	0.87	0.72	0.78	0.91	1.03	1.11	1.11	1.03	1.24	0.74	0.88	0.95	0.95	0.88	1.14	ns
DIFF_SSTL12_T_DCI_F	0.69	0.72	0.82	0.96	0.72	0.80	0.91	1.03	1.11	1.18	1.03	1.33	0.74	0.88	0.95	1.02	0.88	1.23	ns

Table 22 specifies the values of T_{IOTPHZ} and T_{IOIBUFDISABLE}. T_{IOTPHZ} is described as the delay from the T pin to the IOB pad through the output buffer of an IOB pad, when 3-state is enabled (i.e., a high impedance state). T_{IOIBUFDISABLE} is described as the IOB delay from IBUFDISABLE to O output. In HP I/O banks, the internal DCI termination turn-off time is always faster than T_{IOTPHZ} when the DCITERMDISABLE pin is used. In HR I/O banks, the internal IN_TERM termination turn-off time is always faster than T_{IOTPHZ} when the INTERMDISABLE pin is used.

Table 22: IOB 3-state Output Switching Characteristics

Symbol	Description	Speed Grade						Units
		1.0V				0.95V	0.9V	
		-3	-2/-2LE	-1	-1M/-1LM/-1Q	-2LI	-2LE	
T _{IOTPHZ}	T input to pad high-impedance	0.76	0.86	0.99	0.99	0.86	0.62	ns
T _{IOIBUFDISABLE_HR}	IBUF turn-on time from IBUFDISABLE to O output for HR I/O banks	1.72	1.89	2.14	2.14	1.89	2.17	ns
T _{IOIBUFDISABLE_HP}	IBUF turn-on time from IBUFDISABLE to O output for HP I/O banks	1.31	1.46	1.76	1.76	1.46	1.86	ns

I/O Standard Adjustment Measurement Methodology

Input Delay Measurements

Table 23 shows the test setup parameters used for measuring input delay.

Table 23: Input Delay Measurement Methodology

Description	I/O Standard Attribute	$V_L^{(1)(2)}$	$V_H^{(1)(2)}$	$V_{MEAS}^{(1)(4)(6)}$	$V_{REF}^{(1)(3)(5)}$
LVC MOS, 1.2V	LVC MOS12	0.1	1.1	0.6	–
LVC MOS, 1.5V	LVC MOS15	0.1	1.4	0.75	–
LVC MOS, 1.8V	LVC MOS18	0.1	1.7	0.9	–
LVC MOS, 2.5V	LVC MOS25	0.1	2.4	1.25	–
LVC MOS, 3.3V	LVC MOS33	0.1	3.2	1.65	–
LV TTL, 3.3V	LV TTL	0.1	3.2	1.65	–
MOBILE_DDR, 1.8V	MOBILE_DDR	0.1	1.7	0.9	–
PCI33, 3.3V	PCI33_3	0.1	3.2	1.65	–
HSTL (High-Speed Transceiver Logic), Class I, 1.2V	HSTL_I_12	$V_{REF} - 0.5$	$V_{REF} + 0.5$	V_{REF}	0.60
HSTL, Class I & II, 1.5V	HSTL_I, HSTL_II	$V_{REF} - 0.65$	$V_{REF} + 0.65$	V_{REF}	0.75
HSTL, Class I & II, 1.8V	HSTL_I_18, HSTL_II_18	$V_{REF} - 0.8$	$V_{REF} + 0.8$	V_{REF}	0.90
HSUL (High-Speed Unterminated Logic), 1.2V	HSUL_12	$V_{REF} - 0.5$	$V_{REF} + 0.5$	V_{REF}	0.60
SSTL (Stub Terminated Transceiver Logic), 1.2V	SSTL12	$V_{REF} - 0.5$	$V_{REF} + 0.5$	V_{REF}	0.60
SSTL, 1.35V	SSTL135, SSTL135_R	$V_{REF} - 0.575$	$V_{REF} + 0.575$	V_{REF}	0.675
SSTL, 1.5V	SSTL15, SSTL15_R	$V_{REF} - 0.65$	$V_{REF} + 0.65$	V_{REF}	0.75
SSTL, Class I & II, 1.8V	SSTL18_I, SSTL18_II	$V_{REF} - 0.8$	$V_{REF} + 0.8$	V_{REF}	0.90
DIFF_MOBILE_DDR, 1.8V	DIFF_MOBILE_DDR	$0.9 - 0.125$	$0.9 + 0.125$	0 ⁽⁶⁾	–
DIFF_HSTL, Class I, 1.2V	DIFF_HSTL_I_12	$0.6 - 0.125$	$0.6 + 0.125$	0 ⁽⁶⁾	–
DIFF_HSTL, Class I & II, 1.5V	DIFF_HSTL_I, DIFF_HSTL_II	$0.75 - 0.125$	$0.75 + 0.125$	0 ⁽⁶⁾	–
DIFF_HSTL, Class I & II, 1.8V	DIFF_HSTL_I_18, DIFF_HSTL_II_18	$0.9 - 0.125$	$0.9 + 0.125$	0 ⁽⁶⁾	–
DIFF_HSUL, 1.2V	DIFF_HSUL_12	$0.6 - 0.125$	$0.6 + 0.125$	0 ⁽⁶⁾	–
DIFF_SSTL, 1.2V	DIFF_SSTL12	$0.6 - 0.125$	$0.6 + 0.125$	0 ⁽⁶⁾	–
DIFF_SSTL135/DIFF_SSTL135_R, 1.35V	DIFF_SSTL135, DIFF_SSTL135_R	$0.675 - 0.125$	$0.675 + 0.125$	0 ⁽⁶⁾	–
DIFF_SSTL15/DIFF_SSTL15_R, 1.5V	DIFF_SSTL15, DIFF_SSTL15_R	$0.75 - 0.125$	$0.75 + 0.125$	0 ⁽⁶⁾	–
DIFF_SSTL18_I/DIFF_SSTL18_II, 1.8V	DIFF_SSTL18_I, DIFF_SSTL18_II	$0.9 - 0.125$	$0.9 + 0.125$	0 ⁽⁶⁾	–
LVDS (Low-Voltage Differential Signaling), 1.8V	LVDS	$0.9 - 0.125$	$0.9 + 0.125$	0 ⁽⁶⁾	–
LVDS_25, 2.5V	LVDS_25	$1.2 - 0.125$	$1.2 + 0.125$	0 ⁽⁶⁾	–
BLVDS_25, 2.5V	BLVDS_25	$1.25 - 0.125$	$1.25 + 0.125$	0 ⁽⁶⁾	–
MINI_LVDS_25, 2.5V	MINI_LVDS_25	$1.25 - 0.125$	$1.25 + 0.125$	0 ⁽⁶⁾	–
PPDS_25	PPDS_25	$1.25 - 0.125$	$1.25 + 0.125$	0 ⁽⁶⁾	–
RS DS_25	RS DS_25	$1.25 - 0.125$	$1.25 + 0.125$	0 ⁽⁶⁾	–

Table 23: Input Delay Measurement Methodology (Cont'd)

Description	I/O Standard Attribute	V_L (1)(2)	V_H (1)(2)	V_{MEAS} (1)(4)(6)	V_{REF} (1)(3)(5)
TMDS_33	TMDS_33	3 - 0.125	3 + 0.125	0(6)	-

Notes:

1. The input delay measurement methodology parameters for LVDCI are the same for LVCMOS standards of the same voltage. Input delay measurement methodology parameters for HSLVDCI are the same as for HSTL_II standards of the same voltage. Parameters for all other DCI standards are the same for the corresponding non-DCI standards.
2. Input waveform switches between V_L and V_H .
3. Measurements are made at typical, minimum, and maximum V_{REF} values. Reported delays reflect worst case of these measurements. V_{REF} values listed are typical.
4. Input voltage level from which measurement starts.
5. This is an input voltage reference that bears no relation to the V_{REF} / V_{MEAS} parameters found in IBIS models and/or noted in Figure 1.
6. The value given is the differential input voltage.

Output Delay Measurements

Output delays are measured with short output traces. Standard termination was used for all testing. The propagation delay of the trace is characterized separately and subtracted from the final measurement, and is therefore not included in the generalized test setups shown in Figure 1 and Figure 2.

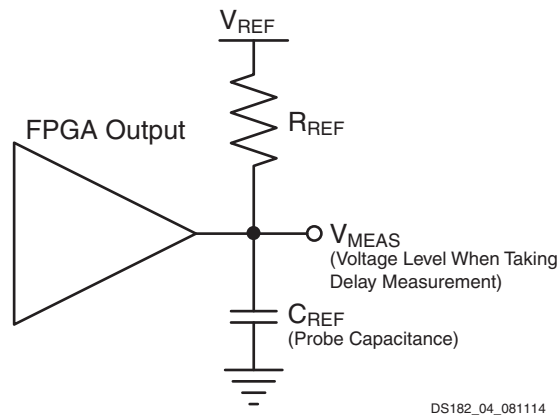

DS182_04_081114

Figure 1: Single-Ended Test Setup

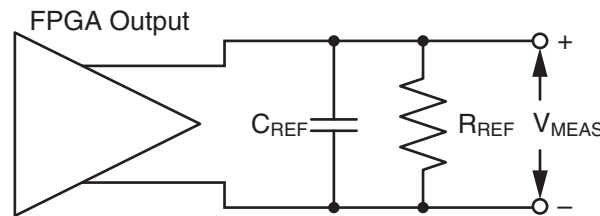

DS182_05_080814

Figure 2: Differential Test Setup

Parameters V_{REF} , R_{REF} , C_{REF} , and V_{MEAS} fully describe the test conditions for each I/O standard. The most accurate prediction of propagation delay in any given application can be obtained through IBIS simulation, using this method:

1. Simulate the output driver of choice into the generalized test setup using values from Table 24.
2. Record the time to V_{MEAS} .
3. Simulate the output driver of choice into the actual PCB trace and load using the appropriate IBIS model or capacitance value to represent the load.
4. Record the time to V_{MEAS} .

5. Compare the results of [step 2](#) and [step 4](#). The increase or decrease in delay yields the actual propagation delay of the PCB trace.

Table 24: Output Delay Measurement Methodology

Description	I/O Standard Attribute	R _{REF} (Ω)	C _{REF} ⁽¹⁾ (pF)	V _{MEAS} (V)	V _{REF} (V)
LVC MOS, 1.2V	LVC MOS12	1M	0	0.6	0
LVC MOS/LVDCI/HSLVDCI, 1.5V	LVC MOS15, LVDCI_15, HSLVDCI_15	1M	0	0.75	0
LVC MOS/LVDCI/HSLVDCI, 1.8V	LVC MOS18, LVDCI_15, HSLVDCI_18	1M	0	0.9	0
LVC MOS, 2.5V	LVC MOS25	1M	0	1.25	0
LVC MOS, 3.3V	LVC MOS33	1M	0	1.65	0
LV TTL, 3.3V	LV TTL	1M	0	1.65	0
PCI33, 3.3V	PCI33_3	25	10	1.65	0
HSTL (High-Speed Transceiver Logic), Class I, 1.2V	HSTL_I_12	50	0	V _{REF}	0.6
HSTL, Class I, 1.5V	HSTL_I	50	0	V _{REF}	0.75
HSTL, Class II, 1.5V	HSTL_II	25	0	V _{REF}	0.75
HSTL, Class I, 1.8V	HSTL_I_18	50	0	V _{REF}	0.9
HSTL, Class II, 1.8V	HSTL_II_18	25	0	V _{REF}	0.9
HSUL (High-Speed Unterminated Logic), 1.2V	HSUL_12	50	0	V _{REF}	0.6
SSTL12, 1.2V	SSTL12	50	0	V _{REF}	0.6
SSTL135/SSTL135_R, 1.35V	SSTL135, SSTL135_R	50	0	V _{REF}	0.675
SSTL15/SSTL15_R, 1.5V	SSTL15, SSTL15_R	50	0	V _{REF}	0.75
SSTL (Stub Series Terminated Logic), Class I & Class II, 1.8V	SSTL18_I, SSTL18_II	50	0	V _{REF}	0.9
DIFF_MOBILE_DDR, 1.8V	DIFF_MOBILE_DDR	50	0	V _{REF}	0.9
DIFF_HSTL, Class I, 1.2V	DIFF_HSTL_I_12	50	0	V _{REF}	0.6
DIFF_HSTL, Class I & II, 1.5V	DIFF_HSTL_I, DIFF_HSTL_II	50	0	V _{REF}	0.75
DIFF_HSTL, Class I & II, 1.8V	DIFF_HSTL_I_18, DIFF_HSTL_II_18	50	0	V _{REF}	0.9
DIFF_HSUL_12, 1.2V	DIFF_HSUL_12	50	0	V _{REF}	0.6
DIFF_SSTL12, 1.2V	DIFF_SSTL12	50	0	V _{REF}	0.6
DIFF_SSTL135/DIFF_SSTL135_R, 1.35V	DIFF_SSTL135, DIFF_SSTL135_R	50	0	V _{REF}	0.675
DIFF_SSTL15/DIFF_SSTL15_R, 1.5V	DIFF_SSTL15, DIFF_SSTL15_R	50	0	V _{REF}	0.75
DIFF_SSTL18, Class I & II, 1.8V	DIFF_SSTL18_I, DIFF_SSTL18_II	50	0	V _{REF}	0.9
LVDS (Low-Voltage Differential Signaling), 1.8V	LVDS	100	0	0 ⁽²⁾	0
LVDS, 2.5V	LVDS_25	100	0	0 ⁽²⁾	0
BLVDS (Bus LVDS), 2.5V	BLVDS_25	100	0	0 ⁽²⁾	0
Mini LVDS, 2.5V	MINI_LVDS_25	100	0	0 ⁽²⁾	0
PPDS_25	PPDS_25	100	0	0 ⁽²⁾	0
RS DS_25	RS DS_25	100	0	0 ⁽²⁾	0
TMDS_33	TMDS_33	50	0	0 ⁽²⁾	3.3

Notes:

1. C_{REF} is the capacitance of the probe, nominally 0 pF.
2. The value given is the differential output voltage.

Input/Output Logic Switching Characteristics

Table 25: ILOGIC Switching Characteristics

Symbol	Description	Speed Grade						Units
		1.0V				0.95V	0.9V	
		-3	-2/-2LE	-1	-1M/-1LM/ -1Q	-2LI	-2LE	
Setup/Hold								
T_{ICE1CK}/T_{ICKCE1}	CE1 pin Setup/Hold with respect to CLK	0.42/0.00	0.48/0.00	0.67/0.00	0.67/0.00	0.48/0.00	0.56/-0.16	ns
T_{ISRCK}/T_{ICKSR}	SR pin Setup/Hold with respect to CLK	0.53/0.01	0.61/0.01	0.99/0.01	0.99/0.01	0.61/0.01	0.88/-0.30	ns
$T_{IDOCKE2}/T_{IOCKDE2}$	D pin Setup/Hold with respect to CLK without Delay (HP I/O banks only)	0.01/0.27	0.01/0.29	0.01/0.34	0.01/0.34	0.01/0.29	0.01/0.41	ns
$T_{IDOCKDE2}/T_{IOCKDDE2}$	DDLY pin Setup/Hold with respect to CLK (using IDELAY) (HP I/O banks only)	0.01/0.27	0.02/0.29	0.02/0.34	0.02/0.34	0.02/0.29	0.01/0.41	ns
$T_{IDOCKE3}/T_{IOCKDE3}$	D pin Setup/Hold with respect to CLK without Delay (HR I/O banks only)	0.01/0.27	0.01/0.29	0.01/0.34	0.01/0.34	0.01/0.29	0.01/0.41	ns
$T_{IDOCKDE3}/T_{IOCKDDE3}$	DDLY pin Setup/Hold with respect to CLK (using IDELAY) (HR I/O banks only)	0.01/0.27	0.02/0.29	0.02/0.34	0.02/0.34	0.02/0.29	0.01/0.41	ns
Combinatorial								
T_{IDIE2}	D pin to O pin propagation delay, no Delay (HP I/O banks only)	0.09	0.10	0.12	0.12	0.10	0.14	ns
T_{IDIDE2}	DDLY pin to O pin propagation delay (using IDELAY) (HP I/O banks only)	0.10	0.11	0.13	0.13	0.11	0.15	ns
T_{IDIE3}	D pin to O pin propagation delay, no Delay (HR I/O banks only)	0.09	0.10	0.12	0.12	0.10	0.14	ns
T_{IDIDE3}	DDLY pin to O pin propagation delay (using IDELAY) (HR I/O banks only)	0.10	0.11	0.13	0.13	0.11	0.15	ns
Sequential Delays								
T_{IDLOE2}	D pin to Q1 pin using flip-flop as a latch without Delay (HP I/O banks only)	0.36	0.39	0.45	0.45	0.39	0.54	ns
T_{IDLDE2}	DDLY pin to Q1 pin using flip-flop as a latch (using IDELAY) (HP I/O banks only)	0.36	0.39	0.45	0.45	0.39	0.55	ns
T_{IDLOE3}	D pin to Q1 pin using flip-flop as a latch without Delay (HR I/O banks only)	0.36	0.39	0.45	0.45	0.39	0.54	ns
T_{IDLDE3}	DDLY pin to Q1 pin using flip-flop as a latch (using IDELAY) (HR I/O banks only)	0.36	0.39	0.45	0.45	0.39	0.55	ns
T_{ICKQ}	CLK to Q outputs	0.47	0.50	0.58	0.58	0.50	0.71	ns
$T_{RQ_ILOGICE2}$	SR pin to OQ/TQ out (HP I/O banks only)	0.84	0.94	1.16	1.16	0.94	1.32	ns
$T_{GSRQ_ILOGICE2}$	Global Set/Reset to Q outputs (HP I/O banks only)	7.60	7.60	10.51	10.51	7.60	11.39	ns
$T_{RQ_ILOGICE3}$	SR pin to OQ/TQ out (HR I/O banks only)	0.84	0.94	1.16	1.16	0.94	1.32	ns
$T_{GSRQ_ILOGICE3}$	Global Set/Reset to Q outputs (HR I/O banks only)	7.60	7.60	10.51	10.51	7.60	11.39	ns

Table 25: ILOGIC Switching Characteristics (Cont'd)

Symbol	Description	Speed Grade						Units
		1.0V				0.95V	0.9V	
		-3	-2/-2LE	-1	-1M/-1LM/ -1Q	-2LI	-2LE	
Set/Reset								
T _{RPW_ILOGICE2}	Minimum Pulse Width, SR inputs (HP I/O banks only)	0.54	0.63	0.63	0.63	0.63	0.68	ns, Min
T _{RPW_ILOGICE3}	Minimum Pulse Width, SR inputs (HR I/O banks only)	0.54	0.63	0.63	0.63	0.63	0.68	ns, Min

Table 26: OLOGIC Switching Characteristics

Symbol	Description	Speed Grade						Units
		1.0V				0.95V	0.9V	
		-3	-2/-2LE	-1	-1M/-1LM/ -1Q	-2LI	-2LE	
Setup/Hold								
T _{ODCK/T_OCKD}	D1/D2 pins Setup/Hold with respect to CLK	0.45/-0.13	0.50/-0.13	0.58/-0.13	0.58/-0.13	0.50/-0.13	0.79/-0.18	ns
T _{OOCECK/ T_OCKOCE}	OCE pin Setup/Hold with respect to CLK	0.28/0.03	0.29/0.03	0.45/0.03	0.45/0.03	0.29/0.03	0.35/-0.10	ns
T _{OSRCK/T_OCKSR}	SR pin Setup/Hold with respect to CLK	0.32/0.18	0.38/0.18	0.70/0.18	0.70/0.18	0.38/0.18	0.62/-0.04	ns
T _{OTCK/T_OCKT}	T1/T2 pins Setup/Hold with respect to CLK	0.49/-0.16	0.56/-0.16	0.68/-0.16	0.68/-0.13	0.56/-0.16	0.67/-0.18	ns
T _{OTCECK/ T_OCKTCE}	TCE pin Setup/Hold with respect to CLK	0.28/0.01	0.30/0.01	0.45/0.01	0.45/0.06	0.30/0.01	0.31/-0.10	ns
Combinatorial								
T _{ODQ}	D1 to OQ out or T1 to TQ out	0.73	0.81	0.97	0.97	0.81	1.18	ns
Sequential Delays								
T _O CKQ	CLK to OQ/TQ out	0.41	0.43	0.49	0.49	0.43	0.63	ns
T _{RQ_OLOGICE2}	SR pin to OQ/TQ out (HP I/O banks only)	0.63	0.70	0.83	0.83	0.70	1.12	ns
T _{GSRQ_OLOGICE2}	Global Set/Reset to Q outputs (HP I/O banks only)	7.60	7.60	10.51	10.51	7.60	11.39	ns
T _{RQ_OLOGICE3}	SR pin to OQ/TQ out (HR I/O banks only)	0.63	0.70	0.83	0.83	0.70	1.12	ns
T _{GSRQ_OLOGICE3}	Global Set/Reset to Q outputs (HR I/O banks only)	7.60	7.60	10.51	10.51	7.60	11.39	ns
Set/Reset								
T _{RPW_OLOGICE2}	Minimum Pulse Width, SR inputs (HP I/O banks only)	0.54	0.54	0.63	0.63	0.54	0.68	ns, Min
T _{RPW_OLOGICE3}	Minimum Pulse Width, SR inputs (HR I/O banks only)	0.54	0.54	0.63	0.63	0.54	0.68	ns, Min

Input Serializer/Deserializer Switching Characteristics

Table 27: ISERDES Switching Characteristics

Symbol	Description	Speed Grade						Units
		1.0V				0.95V	0.9V	
		-3	-2/-2LE	-1	-1M/-1LM/ -1Q	-2LI	-2LE	
Setup/Hold for Control Lines								
$T_{ISCK_BITSLLIP}/$ $T_{ISCKC_BITSLLIP}$	BITSLIP pin Setup/Hold with respect to CLKDIV	0.01/0.12	0.02/0.13	0.02/0.15	0.02/0.15	0.02/0.13	0.02/0.21	ns
$T_{ISCK_CE}/$ $T_{ISCKC_CE}^{(2)}$	CE pin Setup/Hold with respect to CLK (for CE1)	0.39/-0.02	0.44/-0.02	0.63/-0.02	0.63/-0.02	0.44/-0.02	0.51/-0.22	ns
$T_{ISCK_CE2}/$ $T_{ISCKC_CE2}^{(2)}$	CE pin Setup/Hold with respect to CLKDIV (for CE2)	-0.12/0.29	-0.12/0.31	-0.12/0.35	-0.12/0.35	-0.12/0.31	-0.17/0.40	ns
Setup/Hold for Data Lines								
$T_{ISDCK_D}/$ T_{ISCKD_D}	D pin Setup/Hold with respect to CLK	-0.02/0.11	-0.02/0.12	-0.02/0.15	-0.02/0.15	-0.02/0.12	-0.04/0.19	ns
$T_{ISDCK_DDLY}/$ T_{ISCKD_DDLY}	DDLY pin Setup/Hold with respect to CLK (using IDELAY) ⁽¹⁾	-0.02/0.11	-0.02/0.12	-0.02/0.15	-0.02/0.15	-0.02/0.12	-0.03/0.19	ns
$T_{ISDCK_D_DDR}/$ $T_{ISCKD_D_DDR}$	D pin Setup/Hold with respect to CLK at DDR mode	-0.02/0.11	-0.02/0.12	-0.02/0.15	-0.02/0.15	-0.02/0.12	-0.04/0.19	ns
$T_{ISDCK_DDLY_DDR}/$ $T_{ISCKD_DDLY_DDR}$	D pin Setup/Hold with respect to CLK at DDR mode (using IDELAY) ⁽¹⁾	0.11/0.11	0.12/0.12	0.15/0.15	0.15/0.15	0.12/0.12	0.19/0.19	ns
Sequential Delays								
T_{ISCKO_Q}	CLKDIV to out at Q pin	0.46	0.47	0.58	0.58	0.47	0.67	ns
Propagation Delays								
T_{ISDO_DO}	D input to DO output pin	0.09	0.10	0.12	0.12	0.10	0.14	ns

Notes:

- Recorded at 0 tap value.
- T_{ISCK_CE2} and T_{ISCKC_CE2} are reported as T_{ISCK_CE}/T_{ISCKC_CE} in the timing report.

Output Serializer/Deserializer Switching Characteristics

Table 28: OSERDES Switching Characteristics

Symbol	Description	Speed Grade						Units
		1.0V				0.95V	0.9V	
		-3	-2/-2LE	-1	-1M/-1LM/ -1Q	-2LI	-2LE	
Setup/Hold								
$T_{OSDCK_D}/$ T_{OSCKD_D}	D input Setup/Hold with respect to CLKDIV	0.37/0.02	0.40/0.02	0.55/0.02	0.55/0.02	0.40/0.02	0.44/-0.24	ns
$T_{OSDCK_T}/$ $T_{OSCKD_T}^{(1)}$	T input Setup/Hold with respect to CLK	0.49/-0.15	0.56/-0.15	0.68/-0.15	0.68/-0.15	0.56/-0.15	0.67/-0.25	ns
$T_{OSDCK_T2}/$ $T_{OSCKD_T2}^{(1)}$	T input Setup/Hold with respect to CLKDIV	0.27/-0.15	0.30/-0.15	0.34/-0.15	0.34/-0.15	0.30/-0.15	0.46/-0.25	ns
$T_{OSCK_OCE}/$ T_{OSCKC_OCE}	OCE input Setup/Hold with respect to CLK	0.28/0.03	0.29/0.03	0.45/0.03	0.45/0.03	0.29/0.03	0.35/-0.15	ns
T_{OSCK_S}	SR (Reset) input Setup with respect to CLKDIV	0.41	0.46	0.75	0.75	0.46	0.70	ns
$T_{OSCK_TCE}/$ T_{OSCKC_TCE}	TCE input Setup/Hold with respect to CLK	0.28/0.01	0.30/0.01	0.45/0.01	0.45/0.01	0.30/0.01	0.31/-0.15	ns
Sequential Delays								
T_{OSCKO_OQ}	Clock to out from CLK to OQ	0.35	0.37	0.42	0.42	0.37	0.54	ns
T_{OSCKO_TQ}	Clock to out from CLK to TQ	0.41	0.43	0.49	0.49	0.43	0.63	ns
Combinatorial								
T_{OSDO_TQ}	T input to TQ Out	0.73	0.81	0.97	0.97	0.81	1.18	ns

Notes:

- T_{OSDCK_T2} and T_{OSCKD_T2} are reported as T_{OSDCK_T}/T_{OSCKD_T} in the timing report.

Input/Output Delay Switching Characteristics

Table 29: Input/Output Delay Switching Characteristics

Symbol	Description	Speed Grade						Units
		1.0V				0.95V	0.9V	
		-3	-2/-2LE	-1	-1M/-1LM/-1Q	-2LI	-2LE	
IDELAYCTRL								
T _{DLYCCO_RDY}	Reset to Ready for IDELAYCTRL	3.22	3.22	3.22	3.22	3.22	3.22	µs
F _{IDELAYCTRL_REF}	Attribute REFCLK frequency = 200.00 ⁽¹⁾	200.00	200.00	200.00	200.00	200.00	200.00	MHz
	Attribute REFCLK frequency = 300.00 ⁽¹⁾	300.00	300.00	N/A	N/A	300.00	N/A	MHz
	Attribute REFCLK frequency = 400.00 ⁽¹⁾	400.00	400.00	N/A	N/A	400.00	N/A	MHz
IDELAYCTRL_REF_PRECISION	REFCLK precision	±10	±10	±10	±10	±10	±10	MHz
T _{IDELAYCTRL_RPW}	Minimum Reset pulse width	52.00	52.00	52.00	52.00	52.00	52.00	ns
IDELAY/ODELAY								
T _{IDELAYRESOLUTION}	IDELAY/ODELAY chain delay resolution	1/(32 x 2 x F _{REF})						µs
T _{IDELAYPAT_JIT} and T _{ODELAYPAT_JIT}	Pattern dependent period jitter in delay chain for clock pattern. ⁽²⁾	0	0	0	0	0	0	ps per tap
	Pattern dependent period jitter in delay chain for random data pattern (PRBS 23) ⁽³⁾	±5	±5	±5	±5	±5	±5	ps per tap
	Pattern dependent period jitter in delay chain for random data pattern (PRBS 23) ⁽⁴⁾	±9	±9	±9	±9	±9	±9	ps per tap
T _{IDELAY_CLK_MAX} / T _{ODELAY_CLK_MAX}	Maximum frequency of CLK input to IDELAY/ODELAY	800.00	800.00	710.00	710.00	800.00	710.00	MHz
T _{IDCCK_CE} / T _{IDCKC_CE}	CE pin Setup/Hold with respect to C for IDELAY	0.11/0.10	0.14/0.12	0.18/0.14	0.18/0.14	0.14/0.12	0.14/0.16	ns
T _{ODCCK_CE} / T _{ODCKC_CE}	CE pin Setup/Hold with respect to C for ODELAY	0.14/0.03	0.16/0.04	0.19/0.05	0.19/0.05	0.16/0.04	0.28/0.06	ns
T _{IDCCK_INC} / T _{IDCKC_INC}	INC pin Setup/Hold with respect to C for IDELAY	0.10/0.14	0.12/0.16	0.14/0.20	0.14/0.20	0.12/0.16	0.10/0.23	ns
T _{ODCCK_INC} / T _{ODCKC_INC}	INC pin Setup/Hold with respect to C for ODELAY	0.10/0.07	0.12/0.08	0.13/0.09	0.13/0.09	0.12/0.08	0.19/0.16	ns
T _{IDCCK_RST} / T _{IDCKC_RST}	RST pin Setup/Hold with respect to C for IDELAY	0.13/0.08	0.14/0.10	0.16/0.12	0.16/0.12	0.14/0.10	0.22/0.19	ns
T _{ODCCK_RST} / T _{ODCKC_RST}	RST pin Setup/Hold with respect to C for ODELAY	0.16/0.04	0.19/0.06	0.24/0.08	0.24/0.08	0.19/0.06	0.32/0.11	ns
T _{IDDO_IDATAIN}	Propagation delay through IDELAY	Note 5	Note 5	Note 5	Note 5	Note 5	Note 5	ps
T _{ODDO_ODATAIN}	Propagation delay through ODELAY	Note 5	Note 5	Note 5	Note 5	Note 5	Note 5	ps

Notes:

1. Average Tap Delay at 200 MHz = 78 ps, at 300 MHz = 52 ps, and at 400 MHz = 39 ps.
2. When HIGH_PERFORMANCE mode is set to TRUE or FALSE.
3. When HIGH_PERFORMANCE mode is set to TRUE.
4. When HIGH_PERFORMANCE mode is set to FALSE.
5. Delay depends on IDELAY/ODELAY tap setting. See the timing report for actual values.

Table 30: IO_FIFO Switching Characteristics

Symbol	Description	Speed Grade						Units
		1.0V				0.95V	0.9V	
		-3	-2/-2LE	-1	-1M/-1LM/ -1Q	-2LI	-2LE	
IO_FIFO Clock to Out Delays								
T _{OFFCKO_DO}	RDCLK to Q outputs	0.51	0.56	0.63	0.63	0.56	0.81	ns
T _{CKO_FLAGS}	Clock to IO_FIFO Flags	0.59	0.62	0.81	0.81	0.62	0.77	ns
Setup/Hold								
T _{CCK_D} / T _{CKC_D}	D inputs to WRCLK	0.43/-0.01	0.47/-0.01	0.53/-0.01	0.53/0.09	0.47/-0.01	0.76/-0.05	ns
T _{IFFCK_WREN} / T _{IFFCKC_WREN}	WREN to WRCLK	0.39/-0.01	0.43/-0.01	0.50/-0.01	0.50/-0.01	0.43/-0.01	0.70/-0.05	ns
T _{OFFCK_RDEN} / T _{OFFCKC_RDEN}	RDEN to RDCLK	0.49/0.01	0.53/0.02	0.61/0.02	0.61/0.02	0.53/0.02	0.79/-0.02	ns
Minimum Pulse Width								
T _{PWH_IO_FIFO}	RESET, RDCLK, WRCLK	0.81	0.92	1.08	1.08	0.92	1.29	ns
T _{PWL_IO_FIFO}	RESET, RDCLK, WRCLK	0.81	0.92	1.08	1.08	0.92	1.29	ns
Maximum Frequency								
F _{MAX}	RDCLK and WRCLK	533.05	470.37	400.00	400.00	470.37	333.33	MHz

CLB Switching Characteristics

Table 31: CLB Switching Characteristics

Symbol	Description	Speed Grade						Units
		1.0V				0.95V	0.9V	
		-3	-2/-2LE	-1	-1M/-1LM/ -1Q	-2LI	-2LE	
Combinatorial Delays								
T _{ILO}	An – Dn LUT address to A	0.05	0.05	0.06	0.06	0.05	0.07	ns, Max
T _{ILO_2}	An – Dn LUT address to AMUX/CMUX	0.15	0.16	0.19	0.19	0.16	0.22	ns, Max
T _{ILO_3}	An – Dn LUT address to BMUX_A	0.24	0.25	0.30	0.30	0.25	0.37	ns, Max
T _{ITO}	An – Dn inputs to A – D Q outputs	0.58	0.61	0.74	0.74	0.61	0.91	ns, Max
T _{AXA}	AX inputs to AMUX output	0.38	0.40	0.49	0.49	0.40	0.62	ns, Max
T _{AXB}	AX inputs to BMUX output	0.40	0.42	0.52	0.52	0.42	0.66	ns, Max
T _{AXC}	AX inputs to CMUX output	0.39	0.41	0.50	0.50	0.41	0.62	ns, Max
T _{AXD}	AX inputs to DMUX output	0.43	0.44	0.52	0.52	0.44	0.67	ns, Max
T _{BXB}	BX inputs to BMUX output	0.31	0.33	0.40	0.40	0.33	0.51	ns, Max
T _{BXD}	BX inputs to DMUX output	0.38	0.39	0.47	0.47	0.39	0.62	ns, Max
T _{CXC}	CX inputs to CMUX output	0.27	0.28	0.34	0.34	0.28	0.43	ns, Max
T _{CXD}	CX inputs to DMUX output	0.33	0.34	0.41	0.41	0.34	0.54	ns, Max
T _{DXD}	DX inputs to DMUX output	0.32	0.33	0.40	0.40	0.33	0.52	ns, Max
Sequential Delays								
T _{CKO}	Clock to AQ – DQ outputs	0.26	0.27	0.32	0.32	0.27	0.40	ns, Max
T _{SHCKO}	Clock to AMUX – DMUX outputs	0.32	0.32	0.39	0.39	0.32	0.46	ns, Max
Setup and Hold Times of CLB Flip-Flops Before/After Clock CLK								
T _{AS} /T _{AH}	A _N – D _N input to CLK on A – D flip-flops	0.01/0.12	0.02/0.13	0.03/0.18	0.03/0.24	0.02/0.13	0.02/0.18	ns, Min
T _{DICK} /T _{CKDI}	A _X – D _X input to CLK on A – D flip-flops	0.04/0.14	0.04/0.14	0.05/0.20	0.05/0.26	0.04/0.14	0.05/0.21	ns, Min
	A _X – D _X input through MUXs and/or carry logic to CLK on A – D flip-flops	0.36/0.10	0.37/0.11	0.46/0.16	0.46/0.22	0.37/0.11	0.56/0.15	ns, Min
T _{CECK_CLB} / T _{CKCE_CLB}	CE input to CLK on A – D flip-flops	0.19/0.05	0.20/0.05	0.25/0.05	0.25/0.11	0.20/0.05	0.24/0.04	ns, Min
T _{SRCK} /T _{CKSR}	SR input to CLK on A – D flip-flops	0.30/0.05	0.31/0.07	0.37/0.09	0.37/0.22	0.31/0.07	0.48/0.05	ns, Min
Set/Reset								
T _{SRMIN}	SR input minimum pulse width	0.52	0.78	1.04	1.04	0.78	0.95	ns, Min
T _{RQ}	Delay from SR input to AQ – DQ flip-flops	0.38	0.38	0.46	0.46	0.38	0.59	ns, Max
T _{CEO}	Delay from CE input to AQ – DQ flip-flops	0.34	0.35	0.43	0.43	0.35	0.54	ns, Max
F _{TOG}	Toggle frequency (for export control)	1818	1818	1818	1818	1818	1286	MHz

CLB Distributed RAM Switching Characteristics (SLICEM Only)

Table 32: CLB Distributed RAM Switching Characteristics

Symbol	Description	Speed Grade						Units
		1.0V				0.95V	0.9V	
		-3	-2/-2LE	-1	-1M/-1LM/-1Q	-2LI	-2LE	
Sequential Delays								
T _{SHCKO}	Clock to A – B outputs	0.68	0.70	0.85	0.85	0.70	1.08	ns, Max
T _{SHCKO_1}	Clock to AMUX – BMUX outputs	0.91	0.95	1.15	1.15	0.95	1.44	ns, Max
Setup and Hold Times Before/After Clock CLK								
T _{DS_LRAM} / T _{DH_LRAM}	A – D inputs to CLK	0.45/0.23	0.45/0.24	0.54/0.27	0.54/0.28	0.45/0.24	0.69/0.33	ns, Min
T _{AS_LRAM} / T _{AH_LRAM}	Address An inputs to clock	0.13/0.50	0.14/0.50	0.17/0.58	0.17/0.61	0.14/0.50	0.21/0.63	ns, Min
	Address An inputs through MUXs and/or carry logic to clock	0.40/0.16	0.42/0.17	0.52/0.23	0.52/0.29	0.42/0.17	0.63/0.23	ns, Min
T _{WS_LRAM} / T _{WH_LRAM}	WE input to clock	0.29/0.09	0.30/0.09	0.36/0.09	0.36/0.11	0.30/0.09	0.46/0.10	ns, Min
T _{CECK_LRAM} / T _{CKCE_LRAM}	CE input to CLK	0.29/0.09	0.30/0.09	0.37/0.09	0.37/0.11	0.30/0.09	0.47/0.10	ns, Min
Clock CLK								
T _{MPW}	Minimum pulse width	0.68	0.77	0.91	0.91	0.77	1.11	ns, Min
T _{MCP}	Minimum clock period	1.35	1.54	1.82	1.82	1.54	2.22	ns, Min

Notes:

1. T_{SHCKO} also represents the CLK to XMUX output. Refer to the timing report for the CLK to XMUX path.

CLB Shift Register Switching Characteristics (SLICEM Only)

Table 33: CLB Shift Register Switching Characteristics

Symbol	Description	Speed Grade						Units
		1.0V				0.95V	0.9V	
		-3	-2/-2LE	-1	-1M/-1LM/-1Q	-2LI	-2LE	
Sequential Delays								
T _{REG}	Clock to A – D outputs	0.96	0.98	1.20	1.20	0.98	1.35	ns, Max
T _{REG_MUX}	Clock to AMUX – DMUX output	1.19	1.23	1.50	1.50	1.23	1.72	ns, Max
T _{REG_M31}	Clock to DMUX output via M31 output	0.89	0.91	1.10	1.10	0.91	1.25	ns, Max
Setup and Hold Times Before/After Clock CLK								
T _{WS_SHFREG} / T _{WH_SHFREG}	WE input	0.26/0.09	0.27/0.09	0.33/0.09	0.33/0.11	0.27/0.09	0.41/0.10	ns, Min
T _{CECK_SHFREG} / T _{CKCE_SHFREG}	CE input to CLK	0.27/0.09	0.28/0.09	0.33/0.09	0.33/0.11	0.28/0.09	0.42/0.10	ns, Min
T _{DS_SHFREG} / T _{DH_SHFREG}	A – D inputs to CLK	0.28/0.26	0.28/0.26	0.33/0.30	0.33/0.36	0.28/0.26	0.41/0.36	ns, Min
Clock CLK								
T _{MPW_SHFREG}	Minimum pulse width	0.55	0.65	0.78	0.78	0.65	0.91	ns, Min

Block RAM and FIFO Switching Characteristics

Table 34: Block RAM and FIFO Switching Characteristics

Symbol	Description	Speed Grade						Units
		1.0V				0.95V	0.9V	
		-3	-2/-2LE	-1	-1M/-1LM/ -1Q	-2LI	-2LE	
Block RAM and FIFO Clock-to-Out Delays								
T _{RCKO_DO} and T _{RCKO_DO_REG} ⁽¹⁾	Clock CLK to DOUT output (without output register) ⁽²⁾⁽³⁾	1.57	1.80	2.08	2.08	1.80	2.44	ns, Max
	Clock CLK to DOUT output (with output register) ⁽⁴⁾⁽⁵⁾	0.54	0.63	0.75	0.75	0.63	0.86	ns, Max
T _{RCKO_DO_ECC} and T _{RCKO_DO_ECC_REG}	Clock CLK to DOUT output with ECC (without output register) ⁽²⁾⁽³⁾	2.35	2.58	3.26	3.26	2.58	4.49	ns, Max
	Clock CLK to DOUT output with ECC (with output register) ⁽⁴⁾⁽⁵⁾	0.62	0.69	0.80	0.80	0.69	0.94	ns, Max
T _{RCKO_DO_CASCOUT} and T _{RCKO_DO_CASCOUT_REG}	Clock CLK to DOUT output with Cascade (without output register) ⁽²⁾	2.21	2.45	2.80	2.80	2.45	3.19	ns, Max
	Clock CLK to DOUT output with Cascade (with output register) ⁽⁴⁾	0.98	1.08	1.24	1.24	1.08	1.32	ns, Max
T _{RCKO_FLAGS}	Clock CLK to FIFO flags outputs ⁽⁶⁾	0.65	0.74	0.89	0.89	0.74	0.97	ns, Max
T _{RCKO_POINTERS}	Clock CLK to FIFO pointers outputs ⁽⁷⁾	0.79	0.87	0.98	0.98	0.87	1.10	ns, Max
T _{RCKO_PARITY_ECC}	Clock CLK to ECCPARITY in ECC encode only mode	0.66	0.72	0.80	0.80	0.72	0.93	ns, Max
T _{RCKO_SDBIT_ECC} and T _{RCKO_SDBIT_ECC_REG}	Clock CLK to BITERR (without output register)	2.17	2.38	3.01	3.01	2.38	4.15	ns, Max
	Clock CLK to BITERR (with output register)	0.57	0.65	0.76	0.76	0.65	0.89	ns, Max
T _{RCKO_RDADDR_ECC} and T _{RCKO_RDADDR_ECC_REG}	Clock CLK to RDADDR output with ECC (without output register)	0.64	0.74	0.90	0.90	0.74	0.98	ns, Max
	Clock CLK to RDADDR output with ECC (with output register)	0.71	0.79	0.92	0.92	0.79	1.10	ns, Max
Setup and Hold Times Before/After Clock CLK								
T _{RCKC_ADDRA} / T _{RCKC_ADDRA}	ADDR inputs ⁽⁸⁾	0.38/ 0.27	0.42/ 0.28	0.48/ 0.31	0.48/ 0.38	0.42/ 0.28	0.65/ 0.38	ns, Min
T _{RDCK_DI_WF_NC} / T _{RCKD_DI_WF_NC}	Data input setup/hold time when block RAM is configured in WRITE_FIRST or NO_CHANGE mode ⁽⁹⁾	0.49/ 0.51	0.55/ 0.53	0.63/ 0.57	0.63/ 0.57	0.55/ 0.53	0.78/ 0.64	ns, Min
T _{RDCK_DI_RF} / T _{RCKD_DI_RF}	Data input setup/hold time when block RAM is configured in READ_FIRST mode ⁽⁹⁾	0.17/ 0.25	0.19/ 0.29	0.21/ 0.35	0.21/ 0.35	0.19/ 0.29	0.25/ 0.32	ns, Min
T _{RDCK_DI_ECC} / T _{RCKD_DI_ECC}	DIN inputs with block RAM ECC in standard mode ⁽⁹⁾	0.42/ 0.37	0.47/ 0.39	0.53/ 0.43	0.53/ 0.58	0.47/ 0.39	0.66/ 0.46	ns, Min
T _{RDCK_DI_ECCW} / T _{RCKD_DI_ECCW}	DIN inputs with block RAM ECC encode only ⁽⁹⁾	0.79/ 0.37	0.87/ 0.39	0.99/ 0.43	0.99/ 0.58	0.87/ 0.39	1.17/ 0.41	ns, Min
T _{RDCK_DI_ECC_FIFO} / T _{RCKD_DI_ECC_FIFO}	DIN inputs with FIFO ECC in standard mode ⁽⁹⁾	0.89/ 0.47	0.98/ 0.50	1.12/ 0.54	1.12/ 0.69	0.98/ 0.50	1.32/ 0.65	ns, Min

Table 34: Block RAM and FIFO Switching Characteristics (Cont'd)

Symbol	Description	Speed Grade						Units
		1.0V				0.95V	0.9V	
		-3	-2/-2LE	-1	-1M/-1LM/ -1Q	-2LI	-2LE	
T _{RCKK_INJECTBITERR} / T _{RCKK_INJECTBITERR}	Inject single/double bit error in ECC mode	0.49/ 0.30	0.55/ 0.31	0.63/ 0.34	0.63/ 0.43	0.55/ 0.31	0.78/ 0.41	ns, Min
T _{RCKK_EN} / T _{RCKK_EN}	Block RAM Enable (EN) input	0.30/ 0.17	0.33/ 0.18	0.38/ 0.20	0.38/ 0.32	0.33/ 0.18	0.48/ 0.22	ns, Min
T _{RCKK_REGCE} / T _{RCKK_REGCE}	CE input of output register	0.21/ 0.13	0.25/ 0.13	0.31/ 0.14	0.31/ 0.19	0.25/ 0.13	0.34/ 0.16	ns, Min
T _{RCKK_RSTREG} / T _{RCKK_RSTREG}	Synchronous RSTREG input	0.25/ 0.06	0.27/ 0.06	0.29/ 0.06	0.29/ 0.14	0.27/ 0.06	0.35/ 0.06	ns, Min
T _{RCKK_RSTRAM} / T _{RCKK_RSTRAM}	Synchronous RSTRAM input	0.27/ 0.35	0.29/ 0.37	0.31/ 0.39	0.31/ 0.39	0.29/ 0.37	0.34/ 0.40	ns, Min
T _{RCKK_WEA} / T _{RCKK_WEA}	Write Enable (WE) input (Block RAM only)	0.38/ 0.15	0.41/ 0.16	0.46/ 0.17	0.46/ 0.29	0.41/ 0.16	0.54/ 0.19	ns, Min
T _{RCKK_WREN} / T _{RCKK_WREN}	WREN FIFO inputs	0.39/ 0.25	0.39/ 0.30	0.40/ 0.37	0.40/ 0.49	0.39/ 0.30	0.65/ 0.37	ns, Min
T _{RCKK_RDEN} / T _{RCKK_RDEN}	RDEN FIFO inputs	0.36/ 0.26	0.36/ 0.30	0.37/ 0.37	0.37/ 0.49	0.36/ 0.30	0.60/ 0.38	ns, Min
Reset Delays								
T _{RCO_FLAGS}	Reset RST to FIFO flags/pointers ⁽¹⁰⁾	0.76	0.83	0.93	0.93	0.83	1.06	ns, Max
T _{RREC_RST} / T _{RREM_RST}	FIFO reset recovery and removal timing ⁽¹¹⁾	1.59/ -0.68	1.76/ -0.68	2.01/ -0.68	2.01/ -0.68	1.76/ -0.68	2.07/ -0.60	ns, Max
Maximum Frequency								
F _{MAX_BRAM_WF_NC}	Block RAM (Write first and No change modes) When not in SDP RF mode	601.32	543.77	458.09	458.09	543.77	372.44	MHz
F _{MAX_BRAM_RF_PERFORMANCE}	Block RAM (Read first, Performance mode) When in SDP RF mode but no address overlap between port A and port B	601.32	543.77	458.09	458.09	543.77	372.44	MHz
F _{MAX_BRAM_RF_DELAYED_WRITE}	Block RAM (Read first, Delayed_write mode) When in SDP RF mode and there is possibility of overlap between port A and port B addresses	528.26	477.33	400.80	400.80	477.33	317.36	MHz
F _{MAX_CAS_WF_NC}	Block RAM Cascade (Write first, No change mode) When cascade but not in RF mode	551.27	493.83	408.00	408.00	493.83	322.48	MHz
F _{MAX_CAS_RF_PERFORMANCE}	Block RAM Cascade (Read first, Performance mode) When in cascade with RF mode and no possibility of address overlap/one port is disabled	551.27	493.83	408.00	408.00	493.83	322.48	MHz

Table 34: Block RAM and FIFO Switching Characteristics (Cont'd)

Symbol	Description	Speed Grade						Units
		1.0V				0.95V	0.9V	
		-3	-2/-2LE	-1	-1M/-1LM/ -1Q	-2LI	-2LE	
F _{MAX_CAS_RF_DELAYED_WRITE}	When in cascade RF mode and there is a possibility of address overlap between port A and port B	478.24	427.35	350.88	350.88	427.35	267.38	MHz
F _{MAX_FIFO}	FIFO in all modes without ECC	601.32	543.77	458.09	458.09	543.77	372.44	MHz
F _{MAX_ECC}	Block RAM and FIFO in ECC configuration	484.26	430.85	351.12	351.12	430.85	254.13	MHz

Notes:

1. The timing report shows all of these parameters as T_{RCKO_DO}.
2. T_{RCKO_DOR} includes T_{RCKO_DOW}, T_{RCKO_DOPR}, and T_{RCKO_DOPW} as well as the B port equivalent timing parameters.
3. These parameters also apply to synchronous FIFO with DO_REG = 0.
4. T_{RCKO_DO} includes T_{RCKO_DOP} as well as the B port equivalent timing parameters.
5. These parameters also apply to multirate (asynchronous) and synchronous FIFO with DO_REG = 1.
6. T_{RCKO_FLAGS} includes the following parameters: T_{RCKO_AEMPTY}, T_{RCKO_AFULL}, T_{RCKO_EMPTY}, T_{RCKO_FULL}, T_{RCKO_RDERR}, T_{RCKO_WRERR}.
7. T_{RCKO_POINTERS} includes both T_{RCKO_RDCOUNT} and T_{RCKO_WRCOUNT}.
8. The ADDR setup and hold must be met when EN is asserted (even when WE is deasserted). Otherwise, block RAM data corruption is possible.
9. These parameters include both A and B inputs as well as the parity inputs of A and B.
10. T_{RCO_FLAGS} includes the following flags: AEMPTY, AFULL, EMPTY, FULL, RDERR, WRERR, RDCOUNT, and WRCOUNT.
11. RDEN and WREN must be held Low prior to and during reset. The FIFO reset must be asserted for at least five positive clock edges of the slowest clock (WRCLK or RDCLK).

DSP48E1 Switching Characteristics

Table 35: DSP48E1 Switching Characteristics

Symbol	Description	Speed Grade						Units
		1.0V				0.95V	0.9V	
		-3	-2/-2LE	-1	-1M/-1LM/ -1Q	-2LI	-2LE	
Setup and Hold Times of Data/Control Pins to the Input Register Clock								
$T_{DSPDCK_A_AREG}/$ $T_{DSPCKD_A_AREG}$	A input to A register CLK	0.24/ 0.12	0.27/ 0.14	0.31/ 0.16	0.33/ 0.18	0.27/ 0.14	0.38/ 0.12	ns
$T_{DSPDCK_B_BREG}/$ $T_{DSPCKD_B_BREG}$	B input to B register CLK	0.28/ 0.13	0.32/ 0.14	0.39/ 0.15	0.41/ 0.18	0.32/ 0.14	0.51/ 0.16	ns
$T_{DSPDCK_C_CREG}/$ $T_{DSPCKD_C_CREG}$	C input to C register CLK	0.15/ 0.15	0.17/ 0.17	0.20/ 0.20	0.20/ 0.22	0.17/ 0.17	0.31/ 0.21	ns
$T_{DSPDCK_D_DREG}/$ $T_{DSPCKD_D_DREG}$	D input to D register CLK	0.21/ 0.19	0.27/ 0.22	0.35/ 0.26	0.35/ 0.27	0.27/ 0.22	0.46/ 0.20	ns
$T_{DSPDCK_ACIN_AREG}/$ $T_{DSPCKD_ACIN_AREG}$	ACIN input to A register CLK	0.21/ 0.12	0.24/ 0.14	0.27/ 0.16	0.30/ 0.16	0.24/ 0.14	0.31/ 0.12	ns
$T_{DSPDCK_BCIN_BREG}/$ $T_{DSPCKD_BCIN_BREG}$	BCIN input to B register CLK	0.22/ 0.13	0.25/ 0.14	0.30/ 0.15	0.32/ 0.15	0.25/ 0.14	0.34/ 0.16	ns
Setup and Hold Times of Data Pins to the Pipeline Register Clock								
$T_{DSPDCK_A,B_MREG_MULT}/$ T_{DSPCKD_A,B_MREG_MULT}	{A, B} input to M register CLK using multiplier	2.04/ -0.01	2.34/ -0.01	2.79/ -0.01	2.79/ -0.01	2.34/ -0.01	3.66/ -0.06	ns
$T_{DSPDCK_A,D_ADREG}/$ T_{DSPCKD_A,D_ADREG}	{A, D} input to AD register CLK	1.09/ -0.02	1.25/ -0.02	1.49/ -0.02	1.49/ -0.02	1.25/ -0.02	1.94/ -0.23	ns
Setup and Hold Times of Data/Control Pins to the Output Register Clock								
$T_{DSPDCK_A,B_PREG_MULT}/$ T_{DSPCKD_A,B_PREG_MULT}	{A, B} input to P register CLK using multiplier	3.41/ -0.24	3.90/ -0.24	4.64/ -0.24	4.64/ -0.24	3.90/ -0.24	5.89/ -0.41	ns
$T_{DSPDCK_D_PREG_MULT}/$ $T_{DSPCKD_D_PREG_MULT}$	D input to P register CLK using multiplier	3.33/ -0.62	3.81/ -0.62	4.53/ -0.62	4.53/ -0.62	3.81/ -0.62	5.70/ -1.42	ns
$T_{DSPDCK_A,B_PREG}/$ T_{DSPCKD_A,B_PREG}	A or B input to P register CLK not using multiplier	1.47/ -0.24	1.68/ -0.24	2.00/ -0.24	2.00/ -0.24	1.68/ -0.24	2.37/ -0.41	ns
$T_{DSPDCK_C_PREG}/$ $T_{DSPCKD_C_PREG}$	C input to P register CLK not using multiplier	1.30/ -0.22	1.49/ -0.22	1.78/ -0.22	1.78/ -0.22	1.49/ -0.22	2.11/ -0.36	ns
$T_{DSPDCK_PCIN_PREG}/$ $T_{DSPCKD_PCIN_PREG}$	PCIN input to P register CLK	1.12/ -0.13	1.28/ -0.13	1.52/ -0.13	1.52/ -0.13	1.28/ -0.13	1.81/ -0.21	ns
Setup and Hold Times of the CE Pins								
$T_{DSPDCK_CEA,CEB_AREG,BREG}/$ $T_{DSPCKD_CEA,CEB_AREG,BREG}$	{CEA; CEB} input to {A; B} register CLK	0.30/ 0.05	0.36/ 0.06	0.44/ 0.09	0.44/ 0.09	0.36/ 0.06	0.55/ 0.09	ns
$T_{DSPDCK_CEC_CREG}/$ $T_{DSPCKD_CEC_CREG}$	CEC input to C register CLK	0.24/ 0.08	0.29/ 0.09	0.36/ 0.11	0.36/ 0.11	0.29/ 0.09	0.43/ 0.11	ns
$T_{DSPDCK_CED_DREG}/$ $T_{DSPCKD_CED_DREG}$	CED input to D register CLK	0.31/ -0.02	0.36/ -0.02	0.44/ -0.02	0.44/ 0.02	0.36/ -0.02	0.58/ 0.12	ns
$T_{DSPDCK_CEM_MREG}/$ $T_{DSPCKD_CEM_MREG}$	CEM input to M register CLK	0.26/ 0.15	0.29/ 0.17	0.33/ 0.20	0.33/ 0.20	0.29/ 0.17	0.39/ 0.25	ns
$T_{DSPDCK_CEP_PREG}/$ $T_{DSPCKD_CEP_PREG}$	CEP input to P register CLK	0.31/ 0.01	0.36/ 0.01	0.45/ 0.01	0.45/ 0.01	0.36/ 0.01	0.54/ 0.00	ns

Table 35: DSP48E1 Switching Characteristics (Cont'd)

Symbol	Description	Speed Grade						Units
		1.0V				0.95V	0.9V	
		-3	-2/-2LE	-1	-1M/-1LM/ -1Q	-2LI	-2LE	
Setup and Hold Times of the RST Pins								
$T_{DSPDCK_RSTA; RSTB_AREG; BREG}/$ $T_{DSPCKD_RSTA; RSTB_AREG; BREG}$	{RSTA, RSTB} input to {A, B} register CLK	0.34/ 0.10	0.39/ 0.11	0.47/ 0.13	0.47/ 0.14	0.39/ 0.11	0.53/ 0.34	ns
$T_{DSPDCK_RSTC_CREG}/$ $T_{DSPCKD_RSTC_CREG}$	RSTC input to C register CLK	0.06/ 0.22	0.07/ 0.24	0.08/ 0.26	0.08/ 0.26	0.07/ 0.24	0.08/ 0.31	ns
$T_{DSPDCK_RSTD_DREG}/$ $T_{DSPCKD_RSTD_DREG}$	RSTD input to D register CLK	0.37/ 0.06	0.42/ 0.06	0.50/ 0.07	0.50/ 0.07	0.42/ 0.06	0.57/ 0.07	ns
$T_{DSPDCK_RSTM_MREG}/$ $T_{DSPCKD_RSTM_MREG}$	RSTM input to M register CLK	0.18/ 0.18	0.20/ 0.21	0.23/ 0.24	0.23/ 0.24	0.20/ 0.21	0.24/ 0.29	ns
$T_{DSPDCK_RSTP_PREG}/$ $T_{DSPCKD_RSTP_PREG}$	RSTP input to P register CLK	0.24/ 0.01	0.26/ 0.01	0.30/ 0.01	0.30/ 0.11	0.26/ 0.01	0.37/ 0.00	ns
Combinatorial Delays from Input Pins to Output Pins								
$T_{DSPDO_A_CARRYOUT_MULT}$	A input to CARRYOUT output using multiplier	3.21	3.69	4.39	4.39	3.69	5.60	ns
$T_{DSPDO_D_P_MULT}$	D input to P output using multiplier	3.15	3.61	4.30	4.30	3.61	5.44	ns
$T_{DSPDO_A_P}$	A input to P output not using multiplier	1.30	1.48	1.76	1.76	1.48	2.10	ns
$T_{DSPDO_C_P}$	C input to P output	1.13	1.30	1.55	1.55	1.30	1.84	ns
Combinatorial Delays from Input Pins to Cascading Output Pins								
$T_{DSPDO_A; B_ACOUT; BCOUT}$	{A, B} input to {ACOUT, BCOUT} output	0.47	0.53	0.63	0.63	0.53	0.75	ns
$T_{DSPDO_A, B_CARRYCASCOUT_MULT}$	{A, B} input to CARRYCASCOUT output using multiplier	3.44	3.94	4.69	4.69	3.94	5.96	ns
$T_{DSPDO_D_CARRYCASCOUT_MULT}$	D input to CARRYCASCOUT output using multiplier	3.36	3.85	4.58	4.58	3.85	5.77	ns
$T_{DSPDO_A, B_CARRYCASCOUT}$	{A, B} input to CARRYCASCOUT output not using multiplier	1.50	1.72	2.04	2.04	1.72	2.44	ns
$T_{DSPDO_C_CARRYCASCOUT}$	C input to CARRYCASCOUT output	1.34	1.53	1.83	1.83	1.53	2.18	ns
Combinatorial Delays from Cascading Input Pins to All Output Pins								
$T_{DSPDO_ACIN_P_MULT}$	ACIN input to P output using multiplier	3.09	3.55	4.24	4.24	3.55	5.42	ns
$T_{DSPDO_ACIN_P}$	ACIN input to P output not using multiplier	1.16	1.33	1.59	1.59	1.33	2.07	ns
$T_{DSPDO_ACIN_ACOUT}$	ACIN input to ACOUT output	0.32	0.37	0.45	0.45	0.37	0.53	ns
$T_{DSPDO_ACIN_CARRYCASCOUT_MULT}$	ACIN input to CARRYCASCOUT output using multiplier	3.30	3.79	4.52	4.52	3.79	5.76	ns
$T_{DSPDO_ACIN_CARRYCASCOUT}$	ACIN input to CARRYCASCOUT output not using multiplier	1.37	1.57	1.87	1.87	1.57	2.40	ns
$T_{DSPDO_PCIN_P}$	PCIN input to P output	0.94	1.08	1.29	1.29	1.08	1.54	ns

Table 35: DSP48E1 Switching Characteristics (Cont'd)

Symbol	Description	Speed Grade						Units
		1.0V				0.95V	0.9V	
		-3	-2/-2LE	-1	-1M/-1LM/ -1Q	-2LI	-2LE	
T _{DSPDO_PCIN_CARRYCASCOUT}	PCIN input to CARRYCASCOUT output	1.15	1.32	1.57	1.57	1.32	1.88	ns
Clock to Outs from Output Register Clock to Output Pins								
T _{DSPCKO_P_PREG}	CLK PREG to P output	0.33	0.35	0.39	0.39	0.35	0.45	ns
T _{DSPCKO_CARRYCASCOUT_PREG}	CLK PREG to CARRYCASCOUT output	0.44	0.50	0.59	0.59	0.50	0.71	ns
Clock to Outs from Pipeline Register Clock to Output Pins								
T _{DSPCKO_P_MREG}	CLK MREG to P output	1.42	1.64	1.96	1.96	1.64	2.31	ns
T _{DSPCKO_CARRYCASCOUT_MREG}	CLK MREG to CARRYCASCOUT output	1.63	1.87	2.24	2.24	1.87	2.65	ns
T _{DSPCKO_P_ADREG_MULT}	CLK ADREG to P output using multiplier	2.30	2.63	3.13	3.13	2.63	3.90	ns
T _{DSPCKO_CARRYCASCOUT_ADREG_MULT}	CLK ADREG to CARRYCASCOUT output using multiplier	2.51	2.87	3.41	3.41	2.87	4.23	ns
Clock to Outs from Input Register Clock to Output Pins								
T _{DSPCKO_P_AREG_MULT}	CLK AREG to P output using multiplier	3.34	3.83	4.55	4.55	3.83	5.80	ns
T _{DSPCKO_P_BREG}	CLK BREG to P output not using multiplier	1.39	1.59	1.88	1.88	1.59	2.24	ns
T _{DSPCKO_P_CREG}	CLK CREG to P output not using multiplier	1.43	1.64	1.95	1.95	1.64	2.32	ns
T _{DSPCKO_P_DREG_MULT}	CLK DREG to P output using multiplier	3.32	3.80	4.51	4.51	3.80	5.74	ns
Clock to Outs from Input Register Clock to Cascading Output Pins								
T _{DSPCKO_{ACOUT;BCOUT}_{AREG;BREG}}	CLK (ACOUT, BCOUT) to {A,B} register output	0.55	0.62	0.74	0.74	0.62	0.87	ns
T _{DSPCKO_CARRYCASCOUT_{AREG;BREG}_MULT}	CLK (AREG, BREG) to CARRYCASCOUT output using multiplier	3.55	4.06	4.84	4.84	4.06	6.13	ns
T _{DSPCKO_CARRYCASCOUT_BREG}	CLK BREG to CARRYCASCOUT output not using multiplier	1.60	1.82	2.16	2.16	1.82	2.58	ns
T _{DSPCKO_CARRYCASCOUT_DREG_MULT}	CLK DREG to CARRYCASCOUT output using multiplier	3.52	4.03	4.79	4.79	4.03	6.07	ns
T _{DSPCKO_CARRYCASCOUT_CREG}	CLK CREG to CARRYCASCOUT output	1.64	1.88	2.23	2.23	1.88	2.65	ns
Maximum Frequency								
F _{MAX}	With all registers used	741.84	650.20	547.95	547.95	650.20	429.37	MHz
F _{MAX_PATDET}	With pattern detector	627.35	549.75	463.61	463.61	549.75	365.90	MHz
F _{MAX_MULT_NOMREG}	Two register multiply without MREG	412.20	360.75	303.77	303.77	360.75	248.32	MHz
F _{MAX_MULT_NOMREG_PATDET}	Two register multiply without MREG with pattern detect	374.25	327.65	276.01	276.01	327.65	225.73	MHz

Table 35: DSP48E1 Switching Characteristics (Cont'd)

Symbol	Description	Speed Grade						Units
		1.0V				0.95V	0.9V	
		-3	-2/-2LE	-1	-1M/-1LM/-1Q	-2LI	-2LE	
F _{MAX_PREADD_MULT_NOADREG}	Without ADREG	468.82	408.66	342.70	342.70	408.66	263.44	MHz
F _{MAX_PREADD_MULT_NOADREG_PATDET}	Without ADREG with pattern detect	468.82	408.66	342.70	342.70	408.66	263.44	MHz
F _{MAX_NOPIPELINEREG}	Without pipeline registers (MREG, ADREG)	306.84	267.81	225.02	225.02	267.81	177.15	MHz
F _{MAX_NOPIPELINEREG_PATDET}	Without pipeline registers (MREG, ADREG) with pattern detect	285.23	249.13	209.38	209.38	249.13	165.32	MHz

Clock Buffers and Networks

Table 36: Global Clock Switching Characteristics (Including BUFGCTRL)

Symbol	Description	Speed Grade						Units
		1.0V				0.95V	0.9V	
		-3	-2/-2LE	-1	-1M/-1LM/-1Q	-2LI	-2LE	
T _{BCCCK_CE} / T _{BCCCK_CE} ⁽¹⁾	CE pins Setup/Hold	0.12/0.30	0.14/0.38	0.26/0.38	0.26/0.92	0.14/0.38	0.23/0.40	ns
T _{BCCCK_S} / T _{BCCCK_S} ⁽¹⁾	S pins Setup/Hold	0.12/0.30	0.14/0.38	0.26/0.38	0.26/0.92	0.14/0.38	0.23/0.40	ns
T _{BCCKO_O} ⁽²⁾	BUFGCTRL delay from I0/I1 to O	0.08	0.10	0.12	0.12	0.10	0.10	ns
Maximum Frequency								
F _{MAX_BUFG}	Global clock tree (BUFG)	741.00	710.00	625.00	625.00	710.00	560.00	MHz

Notes:

1. T_{BCCCK_CE} and T_{BCCCK_CE} must be satisfied to assure glitch-free operation of the global clock when switching between clocks. These parameters do not apply to the BUFGMUX primitive that assures glitch-free operation. The other global clock setup and hold times are optional; only needing to be satisfied if device operation requires simulation matches on a cycle-for-cycle basis when switching between clocks.
2. T_{BGCKO_O} (BUFG delay from I0 to O) values are the same as T_{BCCKO_O} values.

Table 37: Input/Output Clock Switching Characteristics (BUFIO)

Symbol	Description	Speed Grade						Units
		1.0V				0.95V	0.9V	
		-3	-2/-2LE	-1	-1M/-1LM/-1Q	-2LI	-2LE	
T _{BIOCKO_O}	Clock to out delay from I to O	1.04	1.14	1.32	1.32	1.14	1.48	ns
Maximum Frequency								
F _{MAX_BUFIO}	I/O clock tree (BUFIO)	800.00	800.00	710.00	710.00	800.00	710.00	MHz

Table 38: Regional Clock Buffer Switching Characteristics (BUFR)

Symbol	Description	Speed Grade						Units
		1.0V				0.95V	0.9V	
		-3	-2/-2LE	-1	-1M/-1LM/-1Q	-2LI	-2LE	
T _{BRCKO_O}	Clock to out delay from I to O	0.60	0.65	0.77	0.77	0.65	1.06	ns
T _{BRCKO_O_BYP}	Clock to out delay from I to O with Divide Bypass attribute set	0.30	0.32	0.38	0.38	0.32	0.57	ns
T _{BRDO_O}	Propagation delay from CLR to O	0.71	0.75	0.96	0.96	0.75	0.93	ns
Maximum Frequency								
F _{MAX_BUFR} ⁽¹⁾	Regional clock tree (BUFR)	600.00	540.00	450.00	450.00	540.00	450.00	MHz

Notes:

1. The maximum input frequency to the BUFR and BUFMR is the BUFIO F_{MAX} frequency except for the BUFMR in the -2LE at 0.9V, which has a maximum input frequency of 667 MHz.

Table 39: Horizontal Clock Buffer Switching Characteristics (BUFH)

Symbol	Description	Speed Grade						Units
		1.0V				0.95V	0.9V	
		-3	-2/-2LE	-1	-1M/-1LM/-1Q	-2LI	-2LE	
T _{BHCKO_O}	BUFH delay from I to O	0.10	0.11	0.13	0.13	0.11	0.12	ns
T _{BHCKCK_CE} / T _{BHCKC_CE}	CE pin Setup and Hold	0.20/0.16	0.23/0.20	0.38/0.21	0.38/0.79	0.23/0.20	0.28/0.09	ns
Maximum Frequency								
F _{MAX_BUFH}	Horizontal clock buffer (BUFH)	741.00	710.00	625.00	625.00	710.00	560.00	MHz

Table 40: Duty Cycle Distortion and Clock-Tree Skew

Symbol	Description	Device	Speed Grade						Units	
			1.0V				0.95V	0.9V		
			-3	-2/-2LE	-1	-1M/-1LM	-1Q	-2LI		-2LE
T _{DCD_CLK}	Global Clock Tree Duty Cycle Distortion ⁽¹⁾	All	0.20	0.20	0.20	0.20	0.20	0.20	0.25	ns
T _{CKSKEW}	Global Clock Tree Skew ⁽²⁾	XC7K70T	0.29	0.40	0.40	N/A	N/A	N/A	0.47	ns
		XC7K160T	0.42	0.53	0.57	N/A	N/A	0.53	0.59	ns
		XC7K325T	0.59	0.74	0.79	N/A	N/A	0.74	0.91	ns
		XC7K355T	0.45	0.57	0.59	N/A	N/A	0.57	0.69	ns
		XC7K410T	0.60	0.74	0.79	N/A	N/A	0.74	0.91	ns
		XC7K420T	0.60	0.74	0.79	N/A	N/A	0.74	0.91	ns
		XC7K480T	0.60	0.74	0.79	N/A	N/A	0.74	0.91	ns
		XA7K160T	N/A	N/A	N/A	N/A	0.57	N/A	N/A	ns
		XQ7K325T	N/A	0.74	0.79	0.79	N/A	0.74	0.91	ns
XQ7K410T	N/A	0.74	0.79	0.79	N/A	0.74	0.91	ns		
T _{DCD_BUFIO}	I/O clock tree duty cycle distortion	All	0.12	0.12	0.12	0.12	0.12	0.12	0.12	ns
T _{BUFIOSKEW}	I/O clock tree skew across one clock region	All	0.02	0.02	0.02	0.02	0.02	0.02	0.03	ns

Table 40: Duty Cycle Distortion and Clock-Tree Skew (Cont'd)

Symbol	Description	Device	Speed Grade							Units
			1.0V					0.95V	0.9V	
			-3	-2/-2LE	-1	-1M/-1LM	-1Q	-2LI	-2LE	
T _{DCD_BUFR}	Regional clock tree duty cycle distortion	All	0.15	0.15	0.15	0.15	0.15	0.15	0.15	ns

Notes:

1. These parameters represent the worst-case duty cycle distortion observable at the I/O flip flops. For all I/O standards, IBIS can be used to calculate any additional duty cycle distortion that might be caused by asymmetrical rise/fall times.
2. The T_{CKSKEW} value represents the worst-case clock-tree skew observable between sequential I/O elements. Significantly less clock-tree skew exists for I/O registers that are close to each other and fed by the same or adjacent clock-tree branches. Use the Xilinx Timing Analyzer tools to evaluate clock skew specific to your application.

MMCM Switching Characteristics

Table 41: MMCM Specification

Symbol	Description	Speed Grade						Units
		1.0V				0.95V	0.9V	
		-3	-2/-2LE	-1	-1M/-1LM/-1Q	-2LI	-2LE	
MMCM_F _{INMAX}	Maximum Input Clock Frequency	1066.00	933.00	800.00	800.00	933.00	800.00	MHz
MMCM_F _{INMIN}	Minimum Input Clock Frequency	10.00	10.00	10.00	10.00	10.00	10.00	MHz
MMCM_F _{INJITTER}	Maximum Input Clock Period Jitter	< 20% of clock input period or 1 ns Max						
MMCM_F _{INDUTY}	Allowable Input Duty Cycle: 10–49 MHz	25.00	25.00	25.00	25.00	25.00	25.00	%
	Allowable Input Duty Cycle: 50–199 MHz	30.00	30.00	30.00	30.00	30.00	30.00	%
	Allowable Input Duty Cycle: 200–399 MHz	35.00	35.00	35.00	35.00	35.00	35.00	%
	Allowable Input Duty Cycle: 400–499 MHz	40.00	40.00	40.00	40.00	40.00	40.00	%
	Allowable Input Duty Cycle: >500 MHz	45.00	45.00	45.00	45.00	45.00	45.00	%
MMCM_F _{MIN_PSCLK}	Minimum Dynamic Phase Shift Clock Frequency	0.01	0.01	0.01	0.01	0.01	0.01	MHz
MMCM_F _{MAX_PSCLK}	Maximum Dynamic Phase Shift Clock Frequency	550.00	500.00	450.00	450.00	500.00	450.00	MHz
MMCM_F _{VCOMIN}	Minimum MMCM VCO Frequency	600.00	600.00	600.00	600.00	600.00	600.00	MHz
MMCM_F _{VCOMAX}	Maximum MMCM VCO Frequency	1600.00	1440.00	1200.00	1200.00	1440.00	1200.00	MHz
MMCM_F _{BANDWIDTH}	Low MMCM Bandwidth at Typical ⁽¹⁾	1.00	1.00	1.00	1.00	1.00	1.00	MHz
	High MMCM Bandwidth at Typical ⁽¹⁾	4.00	4.00	4.00	4.00	4.00	4.00	MHz
MMCM_T _{STATPHAOFFSET}	Static Phase Offset of the MMCM Outputs ⁽²⁾	0.12	0.12	0.12	0.12	0.12	0.12	ns
MMCM_T _{OUTJITTER}	MMCM Output Jitter	Note 3						

Table 41: MMCM Specification (Cont'd)

Symbol	Description	Speed Grade						Units
		1.0V				0.95V	0.9V	
		-3	-2/-2LE	-1	-1M/-1LM/ -1Q	-2LI	-2LE	
MMCM_T _{OUTDUTY}	MMCM Output Clock Duty Cycle Precision ⁽⁴⁾	0.20	0.20	0.20	0.20	0.20	0.25	ns
MMCM_T _{LOCKMAX}	MMCM Maximum Lock Time	100.00	100.00	100.00	100.00	100.00	100.00	μs
MMCM_F _{OUTMAX}	MMCM Maximum Output Frequency	1066.00	933.00	800.00	800.00	933.00	800.00	MHz
MMCM_F _{OUTMIN}	MMCM Minimum Output Frequency ⁽⁵⁾⁽⁶⁾	4.69	4.69	4.69	4.69	4.69	4.69	MHz
MMCM_T _{EXTFDVAR}	External Clock Feedback Variation	< 20% of clock input period or 1 ns Max						
MMCM_RST _{MINPULSE}	Minimum Reset Pulse Width	5.00	5.00	5.00	5.00	5.00	5.00	ns
MMCM_F _{PFDMAX}	Maximum Frequency at the Phase Frequency Detector	550.00	500.00	450.00	450.00	500.00	450.00	MHz
MMCM_F _{PFDMIN}	Minimum Frequency at the Phase Frequency Detector	10.00	10.00	10.00	10.00	10.00	10.00	MHz
MMCM_T _{FBDELAY}	Maximum Delay in the Feedback Path	3 ns Max or one CLKIN cycle						
MMCM Switching Characteristics Setup and Hold								
T _{MMCMDCK_PSEN/} T _{MMCMCKD_PSEN}	Setup and Hold of Phase Shift Enable	1.04/0.00	1.04/0.00	1.04/0.00	1.04/0.00	1.04/0.00	1.04/0.00	ns
T _{MMCMDCK_PSINCDEC/} T _{MMCMCKD_PSINCDEC}	Setup and Hold of Phase Shift Increment/Decrement	1.04/0.00	1.04/0.00	1.04/0.00	1.04/0.00	1.04/0.00	1.04/0.00	ns
T _{MMCMCKO_PSDONE}	Phase Shift Clock-to-Out of PSDONE	0.59	0.68	0.81	0.81	0.68	0.78	ns
Dynamic Reconfiguration Port (DRP) for MMCM Before and After DCLK								
T _{MMCMDCK_DADDR/} T _{MMCMCKD_DADDR}	DADDR Setup/Hold	1.25/0.15	1.40/0.15	1.63/0.15	1.63/0.15	1.40/0.15	1.43/0.00	ns, Min
T _{MMCMDCK_DI/} T _{MMCMCKD_DI}	DI Setup/Hold	1.25/0.15	1.40/0.15	1.63/0.15	1.63/0.15	1.40/0.15	1.43/0.00	ns, Min
T _{MMCMDCK_DEN/} T _{MMCMCKD_DEN}	DEN Setup/Hold	1.76/0.00	1.97/0.00	2.29/0.00	2.29/0.00	1.97/0.00	2.40/0.00	ns, Min
T _{MMCMDCK_DWE/} T _{MMCMCKD_DWE}	DWE Setup/Hold	1.25/0.15	1.40/0.15	1.63/0.15	1.63/0.15	1.40/0.15	1.43/0.00	ns, Min
T _{MMCMCKO_DRDY}	CLK to out of DRDY	0.65	0.72	0.99	0.99	0.72	0.70	ns, Max
F _{DCK}	DCLK frequency	200.00	200.00	200.00	200.00	200.00	100.00	MHz, Max

Notes:

1. The MMCM does not filter typical spread-spectrum input clocks because they are usually far below the bandwidth filter frequencies.
2. The static offset is measured between any MMCM outputs with identical phase.
3. Values for this parameter are available in the Clocking Wizard.
See www.xilinx.com/products/intellectual-property/clocking_wizard.htm.
4. Includes global clock buffer.
5. Calculated as F_{VCO}/128 assuming output duty cycle is 50%.
6. When CLKOUT4_CASCADE = TRUE, MMCM_F_{OUTMIN} is 0.036 MHz.

PLL Switching Characteristics

Table 42: PLL Specification

Symbol	Description	Speed Grade						Units
		1.0V				0.95V	0.9V	
		-3	-2/-2LE	-1	-1M/-1LM/ -1Q	-2LI	-2LE	
PLL_F _{INMAX}	Maximum Input Clock Frequency	1066.00	933.00	800.00	800.00	933.00	800.00	MHz
PLL_F _{INMIN}	Minimum Input Clock Frequency	19.00	19.00	19.00	19.00	19.00	19.00	MHz
PLL_F _{INJITTER}	Maximum Input Clock Period Jitter	< 20% of clock input period or 1 ns Max						
PLL_F _{INDUTY}	Allowable Input Duty Cycle: 19–49 MHz	25.00	25.00	25.00	25.00	25.00	25.00	%
	Allowable Input Duty Cycle: 50–199 MHz	30.00	30.00	30.00	30.00	30.00	30.00	%
	Allowable Input Duty Cycle: 200–399 MHz	35.00	35.00	35.00	35.00	35.00	35.00	%
	Allowable Input Duty Cycle: 400–499 MHz	40.00	40.00	40.00	40.00	40.00	40.00	%
	Allowable Input Duty Cycle: >500 MHz	45.00	45.00	45.00	45.00	45.00	45.00	%
PLL_F _{VCOMIN}	Minimum PLL VCO Frequency	800.00	800.00	800.00	800.00	800.00	800.00	MHz
PLL_F _{VCOMAX}	Maximum PLL VCO Frequency	2133.00	1866.00	1600.00	1600.00	1866.00	1600.00	MHz
PLL_F _{BANDWIDTH}	Low PLL Bandwidth at Typical ⁽¹⁾	1.00	1.00	1.00	1.00	1.00	1.00	MHz
	High PLL Bandwidth at Typical ⁽¹⁾	4.00	4.00	4.00	4.00	4.00	4.00	MHz
PLL_T _{STATPHAOFFSET}	Static Phase Offset of the PLL Outputs ⁽²⁾	0.12	0.12	0.12	0.12	0.12	0.12	ns
PLL_T _{OUTJITTER}	PLL Output Jitter	Note 3						
PLL_T _{OUTDUTY}	PLL Output Clock Duty Cycle Precision ⁽⁴⁾	0.20	0.20	0.20	0.20	0.20	0.25	ns
PLL_T _{LOCKMAX}	PLL Maximum Lock Time	100	100	100	100	100	100	µs
PLL_F _{OUTMAX}	PLL Maximum Output Frequency	1066.00	933.00	800.00	800.00	933.00	800.00	MHz
PLL_F _{OUTMIN}	PLL Minimum Output Frequency ⁽⁵⁾	6.25	6.25	6.25	6.25	6.25	6.25	MHz
PLL_T _{EXTFDVAR}	External Clock Feedback Variation	< 20% of clock input period or 1 ns Max						
PLL_RST _{MINPULSE}	Minimum Reset Pulse Width	5.00	5.00	5.00	5.00	5.00	5.00	ns
PLL_F _{PFDMAX}	Maximum Frequency at the Phase Frequency Detector	550.00	500.00	450.00	450.00	500.00	450.00	MHz
PLL_F _{PFDMIN}	Minimum Frequency at the Phase Frequency Detector	19.00	19.00	19.00	19.00	19.00	19.00	MHz
PLL_T _{FBDELAY}	Maximum Delay in the Feedback Path	3 ns Max or one CLKIN cycle						
Dynamic Reconfiguration Port (DRP) for PLL Before and After DCLK								
T _{PLLCKC_DADDR} / T _{PLLCKC_DADDR}	Setup and hold of D address	1.25/0.15	1.40/0.15	1.63/0.15	1.63/0.15	1.40/0.15	1.43/0.00	ns, Min
T _{PLLCKC_DI} / T _{PLLCKC_DI}	Setup and hold of D input	1.25/0.15	1.40/0.15	1.63/0.15	1.63/0.15	1.40/0.15	1.43/0.00	ns, Min

Table 42: PLL Specification (Cont'd)

Symbol	Description	Speed Grade						Units
		1.0V				0.95V	0.9V	
		-3	-2/-2LE	-1	-1M/-1LM/ -1Q	-2LI	-2LE	
$T_{PLLCK_DEN}/$ T_{PLLCK_DEN}	Setup and hold of D enable	1.76/0.00	1.97/0.00	2.29/0.00	2.29/0.00	1.97/0.00	2.40/0.00	ns, Min
$T_{PLLCK_DWE}/$ T_{PLLCK_DWE}	Setup and hold of D write enable	1.25/0.15	1.40/0.15	1.63/0.15	1.63/0.15	1.40/0.15	1.43/0.00	ns, Min
T_{PLLCKO_DRDY}	CLK to out of DRDY	0.65	0.72	0.99	0.99	0.72	0.70	ns, Max
F_{DCK}	DCLK frequency	200.00	200.00	200.00	200.00	200.00	100.00	MHz, Max

Notes:

1. The PLL does not filter typical spread-spectrum input clocks because they are usually far below the bandwidth filter frequencies.
2. The static offset is measured between any PLL outputs with identical phase.
3. Values for this parameter are available in the Clocking Wizard.
See www.xilinx.com/products/intellectual-property/clocking_wizard.htm.
4. Includes global clock buffer.
5. Calculated as $F_{VCO}/128$ assuming output duty cycle is 50%.

Device Pin-to-Pin Output Parameter Guidelines

Table 43: Clock-Capable Clock Input to Output Delay Without MMCM/PLL (Near Clock Region)

Symbol	Description	Device	Speed Grade						Units	
			1.0V					0.95V		0.9V
			-3	-2/-2LE	-1	-1M/-1LM	-1Q	-2LI		-2LE
SSTL15 Clock-Capable Clock Input to Output Delay using Output Flip-Flop, Fast Slew Rate, <i>without</i> MMCM/PLL.										
T _{ICKOFF}	Clock-capable clock input and OUTFF at pins/banks closest to the BUFGs <i>without</i> MMCM/PLL (near clock region)	XC7K70T	4.98	5.49	6.17	N/A	N/A	N/A	7.04	ns
		XC7K160T	5.23	5.77	6.48	N/A	N/A	5.77	7.38	ns
		XC7K325T	5.72	6.31	7.09	N/A	N/A	6.31	8.07	ns
		XC7K355T	5.34	5.87	6.57	N/A	N/A	5.87	7.51	ns
		XC7K410T	5.84	6.44	7.22	N/A	N/A	6.44	8.21	ns
		XC7K420T	5.50	6.04	6.77	N/A	N/A	6.04	7.73	ns
		XC7K480T	5.50	6.04	6.77	N/A	N/A	6.04	7.73	ns
		XA7K160T	N/A	N/A	N/A	N/A	6.48	N/A	N/A	ns
		XQ7K325T	N/A	6.31	7.09	7.09	N/A	6.31	8.07	ns
		XQ7K410T	N/A	6.44	7.22	7.22	N/A	6.44	8.21	ns

Notes:

1. Listed above are representative values where one global clock input drives one vertical clock line in each accessible column, and where all accessible IOB and CLB flip-flops are clocked by the global clock net.
2. Refer to the Die Level Bank Numbering Overview section of the *7 Series FPGA Packaging and Pinout Specification* ([UG475](#)).

Table 44: Clock-Capable Clock Input to Output Delay Without MMCM/PLL (Far Clock Region)

Symbol	Description	Device	Speed Grade						Units	
			1.0V					0.95V		0.9V
			-3	-2/-2LE	-1	-1M/-1LM	-1Q	-2LI		-2LE
SSTL15 Clock-Capable Clock Input to Output Delay using Output Flip-Flop, Fast Slew Rate, <i>without</i> MMCM/PLL.										
T _{ICKOFFAR}	Clock-capable clock input and OUTFF at pins/banks farthest from the BUFGs <i>without</i> MMCM/PLL (far clock region)	XC7K70T	5.29	5.83	6.55	N/A	N/A	N/A	7.47	ns
		XC7K160T	5.84	6.45	7.24	N/A	N/A	6.45	8.24	ns
		XC7K325T	6.33	6.99	7.84	N/A	N/A	6.99	8.92	ns
		XC7K355T	5.95	6.55	7.32	N/A	N/A	6.55	8.36	ns
		XC7K410T	6.45	7.12	7.97	N/A	N/A	7.12	9.07	ns
		XC7K420T	6.41	7.06	7.90	N/A	N/A	7.06	9.01	ns
		XC7K480T	6.41	7.06	7.90	N/A	N/A	7.06	9.01	ns
		XA7K160T	N/A	N/A	N/A	N/A	7.24	N/A	N/A	ns
		XQ7K325T	N/A	6.99	7.84	7.84	N/A	6.99	8.92	ns
		XQ7K410T	N/A	7.12	7.97	7.97	N/A	7.12	9.07	ns

Notes:

1. Listed above are representative values where one global clock input drives one vertical clock line in each accessible column, and where all accessible IOB and CLB flip-flops are clocked by the global clock net.
2. Refer to the Die Level Bank Numbering Overview section of the *7 Series FPGA Packaging and Pinout Specification* ([UG475](#)).

Table 45: Clock-Capable Clock Input to Output Delay With MMCM

Symbol	Description	Device	Speed Grade							Units
			1.0V					0.95V	0.9V	
			-3	-2/-2LE	-1	-1M/-1LM	-1Q	-2LI	-2LE	
SSTL15 Clock-Capable Clock Input to Output Delay using Output Flip-Flop, Fast Slew Rate, with MMCM.										
T _{ICKOFFMMCMCC}	Clock-capable clock input and OUTFF with MMCM	XC7K70T	0.95	0.95	0.95	N/A	N/A	N/A	1.74	ns
		XC7K160T	0.96	0.96	0.96	N/A	N/A	0.96	1.78	ns
		XC7K325T	1.00	1.00	1.00	N/A	N/A	1.00	1.82	ns
		XC7K355T	1.00	1.00	1.00	N/A	N/A	1.00	1.78	ns
		XC7K410T	1.00	1.00	1.00	N/A	N/A	1.00	1.82	ns
		XC7K420T	1.07	1.07	1.07	N/A	N/A	1.07	1.82	ns
		XC7K480T	1.07	1.07	1.07	N/A	N/A	1.07	1.82	ns
		XA7K160T	N/A	N/A	N/A	N/A	0.96	N/A	N/A	ns
		XQ7K325T	N/A	1.00	1.00	1.00	N/A	1.00	1.82	ns
		XQ7K410T	N/A	1.00	1.00	1.00	N/A	1.00	1.82	ns

Notes:

1. Listed above are representative values where one global clock input drives one vertical clock line in each accessible column, and where all accessible IOB and CLB flip-flops are clocked by the global clock net.
2. MMCM output jitter is already included in the timing calculation.

Table 46: Clock-Capable Clock Input to Output Delay With PLL

Symbol	Description	Device	Speed Grade							Units
			1.0V					0.95V	0.9V	
			-3	-2/-2LE	-1	-1M/-1LM	-1Q	-2LI	-2LE	
SSTL15 Clock-Capable Clock Input to Output Delay using Output Flip-Flop, Fast Slew Rate, with PLL.										
T _{ICKOFFPLLCC}	Clock-capable clock input and OUTFF with PLL	XC7K70T	0.84	0.84	0.84	N/A	N/A	N/A	1.45	ns
		XC7K160T	0.89	0.89	0.89	N/A	N/A	0.89	1.54	ns
		XC7K325T	0.89	0.89	0.89	N/A	N/A	0.89	1.54	ns
		XC7K355T	0.89	0.89	0.89	N/A	N/A	0.89	1.50	ns
		XC7K410T	0.89	0.89	0.89	N/A	N/A	0.89	1.54	ns
		XC7K420T	0.96	0.96	0.96	N/A	N/A	0.96	1.54	ns
		XC7K480T	0.96	0.96	0.96	N/A	N/A	0.96	1.54	ns
		XA7K160T	N/A	N/A	N/A	N/A	0.89	N/A	N/A	ns
		XQ7K325T	N/A	0.89	0.89	0.89	N/A	0.89	1.54	ns
		XQ7K410T	N/A	0.89	0.89	0.89	N/A	0.89	1.54	ns

Notes:

1. Listed above are representative values where one global clock input drives one vertical clock line in each accessible column, and where all accessible IOB and CLB flip-flops are clocked by the global clock net.
2. PLL output jitter is already included in the timing calculation.

Table 47: Pin-to-Pin, Clock-to-Out using BUFIO

Symbol	Description	Speed Grade						Units
		1.0V				0.95V	0.9V	
		-3	-2/-2LE	-1	-1M/-1LM/-1Q	-2LI	-2LE	
SSTL15 Clock-Capable Clock Input to Output Delay using Output Flip-Flop, Fast Slew Rate, with BUFIO.								
T _{ICKOFCs}	Clock-to-Out of I/O clock for HR I/O banks	4.93	5.52	6.20	6.20	5.52	6.97	ns
	Clock-to-Out of I/O clock for HP I/O banks	4.85	5.44	6.11	6.11	5.44	6.90	ns

Device Pin-to-Pin Input Parameter Guidelines

Table 48: Global Clock Input Setup and Hold Without MMCM/PLL with ZHOLD_DELAY on HR I/O Banks

Symbol	Description	Device	Speed Grade						Units	
			1.0V				0.95V	0.9V		
			-3	-2/-2LE	-1	-1M/-1LM	-1Q	-2LI		-2LE
Input Setup and Hold Time Relative to Global Clock Input Signal for SSTL15 Standard. ⁽¹⁾										
T _{PSFD} /T _{PHFD}	Full Delay (Legacy Delay or Default Delay) Global Clock Input and IFF ⁽²⁾ without MMCM/PLL with ZHOLD_DELAY on HR I/O Banks	XC7K70T	2.83/ -0.29	2.95/ -0.29	3.15/ -0.29	N/A	N/A	N/A	4.96/ -0.33	ns
		XC7K160T	3.17/ -0.35	3.29/ -0.35	3.55/ -0.35	N/A	N/A	3.29/ -0.35	5.54/ -0.49	ns
		XC7K325T	2.83/ -0.06	2.94/ -0.06	3.15/ -0.06	N/A	N/A	2.94/ -0.06	5.18/ -0.14	ns
		XC7K355T	3.26/ -0.32	3.41/ -0.32	3.67/ -0.32	N/A	N/A	3.41/ -0.32	5.84/ -0.49	ns
		XC7K410T	3.43/ -0.34	3.59/ -0.34	3.88/ -0.34	N/A	N/A	3.59/ -0.34	6.21/ -0.54	ns
		XC7K420T	3.37/ -0.27	3.48/ -0.27	3.76/ -0.27	N/A	N/A	3.48/ -0.27	6.00/ -0.52	ns
		XC7K480T	3.37/ -0.27	3.48/ -0.27	3.76/ -0.27	N/A	N/A	3.48/ -0.27	6.00/ -0.52	ns
		XA7K160T	N/A	N/A	N/A	N/A	3.55/ -0.35	N/A	N/A	ns
		XQ7K325T	N/A	2.94/ -0.06	3.15/ -0.06	3.15/ -0.06	N/A	2.94/ -0.06	5.18/ -0.14	ns
		XQ7K410T	N/A	3.59/ -0.34	3.88/ -0.34	3.88/ -0.34	N/A	3.59/ -0.34	6.21/ -0.54	ns

Notes:

1. Setup and Hold times are measured over worst case conditions (process, voltage, temperature). Setup time is measured relative to the Global Clock input signal using the slowest process, highest temperature, and lowest voltage. Hold time is measured relative to the Global Clock input signal using the fastest process, lowest temperature, and highest voltage.
2. IFF = Input Flip-Flop or Latch.

Table 49: Clock-Capable Clock Input Setup and Hold With MMCM

Symbol	Description	Device	Speed Grade						Units	
			1.0V				0.95V	0.9V		
			-3	-2/-2LE	-1	-1M/-1LM	-1Q	-2LI		-2LE
Input Setup and Hold Time Relative to Global Clock Input Signal for SSTL15 Standard. ⁽¹⁾										
T _{PSMMCMCC} / T _{PHMMCMCC}	No Delay clock-capable clock input and IFF ⁽²⁾ with MMCM	XC7K70T	2.39/ -0.22	2.65/ -0.22	2.94/ -0.22	N/A	N/A	N/A	2.21/ -0.44	ns
		XC7K160T	2.49/ -0.20	2.77/ -0.20	3.07/ -0.20	N/A	N/A	2.77/ -0.20	2.38/ -0.47	ns
		XC7K325T	2.55/ -0.16	2.85/ -0.16	3.14/ -0.16	N/A	N/A	2.85/ -0.16	2.60/ -0.47	ns
		XC7K355T	2.43/ -0.16	2.73/ -0.16	3.00/ -0.16	N/A	N/A	2.73/ -0.16	2.47/ -0.43	ns
		XC7K410T	2.55/ -0.16	2.84/ -0.16	3.14/ -0.16	N/A	N/A	2.84/ -0.16	2.58/ -0.47	ns
		XC7K420T	2.47/ -0.09	2.73/ -0.09	3.02/ -0.09	N/A	N/A	2.73/ -0.09	2.40/ -0.41	ns
		XC7K480T	2.47/ -0.09	2.73/ -0.09	3.02/ -0.09	N/A	N/A	2.73/ -0.09	2.40/ -0.41	ns
		XA7K160T	N/A	N/A	N/A	N/A	3.07/ -0.20	N/A	N/A	ns
		XQ7K325T	N/A	2.85/ -0.16	3.14/ -0.16	3.14/ -0.16	N/A	2.85/ -0.16	2.60/ -0.47	ns
		XQ7K410T	N/A	2.84/ -0.16	3.14/ -0.16	3.14/ -0.16	N/A	2.84/ -0.16	2.58/ -0.47	ns

Notes:

1. Setup and Hold times are measured over worst case conditions (process, voltage, temperature). Setup time is measured relative to the Global Clock input signal using the slowest process, highest temperature, and lowest voltage. Hold time is measured relative to the Global Clock input signal using the fastest process, lowest temperature, and highest voltage.
2. IFF = Input Flip-Flop or Latch
3. Use IBIS to determine any duty-cycle distortion incurred using various standards.

Table 50: Clock-Capable Clock Input Setup and Hold With PLL

Symbol	Description	Device	Speed Grade						Units	
			1.0V				0.95V	0.9V		
			-3	-2/-2LE	-1	-1M/-1LM	-1Q	-2LI		-2LE
Input Setup and Hold Time Relative to Clock-Capable Clock Input Signal for SSTL15 Standard. ⁽¹⁾										
T _{PSPLLCC} / T _{PHPLLCC}	No Delay clock-capable clock input and IFF ⁽²⁾ with PLL	XC7K70T	2.75/ -0.32	3.04/ -0.32	3.33/ -0.32	N/A	N/A	N/A	2.42/ -0.54	ns
		XC7K160T	2.85/ -0.31	3.16/ -0.31	3.46/ -0.31	N/A	N/A	3.16/ -0.31	2.59/ -0.56	ns
		XC7K325T	2.91/ -0.27	3.24/ -0.27	3.54/ -0.27	N/A	N/A	3.24/ -0.27	2.80/ -0.56	ns
		XC7K355T	2.79/ -0.27	3.12/ -0.27	3.40/ -0.27	N/A	N/A	3.12/ -0.27	2.67/ -0.52	ns
		XC7K410T	2.91/ -0.27	3.24/ -0.27	3.53/ -0.27	N/A	N/A	3.24/ -0.27	2.78/ -0.56	ns
		XC7K420T	2.83/ -0.20	3.12/ -0.20	3.41/ -0.20	N/A	N/A	3.12/ -0.20	2.61/ -0.50	ns
		XC7K480T	2.83/ -0.20	3.12/ -0.20	3.41/ -0.20	N/A	N/A	3.12/ -0.20	2.61/ -0.50	ns
		XA7K160T	N/A	N/A	N/A	N/A	3.46/ -0.31	N/A	N/A	ns
		XQ7K325T	N/A	3.24/ -0.27	3.54/ -0.27	3.54/ -0.27	N/A	3.24/ -0.27	2.80/ -0.56	ns
		XQ7K410T	N/A	3.24/ -0.27	3.53/ -0.27	3.53/ -0.27	N/A	3.24/ -0.27	2.78/ -0.56	ns

Notes:

1. Setup and Hold times are measured over worst case conditions (process, voltage, temperature). Setup time is measured relative to the Global Clock input signal using the slowest process, highest temperature, and lowest voltage. Hold time is measured relative to the Global Clock input signal using the fastest process, lowest temperature, and highest voltage.
2. IFF = Input Flip-Flop or Latch
3. Use IBIS to determine any duty-cycle distortion incurred using various standards.

Table 51: Data Input Setup and Hold Times Relative to a Forwarded Clock Input Pin Using BUFIO

Symbol	Description	Speed Grade						Units
		1.0V				0.95V	0.9V	
		-3	-2/-2LE	-1	-1M/-1LM/-1Q	-2LI	-2LE	
Input Setup and Hold Time Relative to a Forwarded Clock Input Pin Using BUFIO for SSTL15 Standard.								
T _{PSCS} /T _{PHCS}	Setup/Hold of I/O clock for HR I/O banks	-0.36/1.36	-0.36/1.50	-0.36/1.70	-0.36/1.70	-0.36/1.50	-0.44/1.87	ns
	Setup/Hold of I/O clock for HP I/O banks	-0.34/1.39	-0.34/1.53	-0.34/1.73	-0.34/1.73	-0.34/1.53	-0.44/1.87	ns

Table 52: Sample Window

Symbol	Description	Speed Grade						Units
		1.0V				0.95V	0.9V	
		-3	-2/-2LE	-1	-1M/-1LM/-1Q	-2LI	-2LE	
T _{SAMP}	Sampling Error at Receiver Pins ⁽¹⁾	0.51	0.56	0.61	0.61	0.56	0.56	ns

Table 52: Sample Window (Cont'd)

Symbol	Description	Speed Grade						Units
		1.0V				0.95V	0.9V	
		-3	-2/-2LE	-1	-1M/-1LM/-1Q	-2LI	-2LE	
T _{SAMP_BUFIO}	Sampling Error at Receiver Pins using BUFIO ⁽²⁾	0.30	0.35	0.40	0.40	0.35	0.35	ns

Notes:

1. This parameter indicates the total sampling error of the Kintex-7 FPGAs DDR input registers, measured across voltage, temperature, and process. The characterization methodology uses the MMCM to capture the DDR input registers' edges of operation. These measurements include:
 - CLK0 MMCM jitter
 - MMCM accuracy (phase offset)
 - MMCM phase shift resolution
 These measurements do not include package or clock tree skew.
2. This parameter indicates the total sampling error of the Kintex-7 FPGAs DDR input registers, measured across voltage, temperature, and process. The characterization methodology uses the BUFIO clock network and IDELAY to capture the DDR input registers' edges of operation. These measurements do not include package or clock tree skew.

Additional Package Parameter Guidelines

The parameters in this section provide the necessary values for calculating timing budgets for Kintex-7 FPGA clock transmitter and receiver data-valid windows.

Table 53: Package Skew

Symbol	Description	Device	Package	Value	Units	
T _{PKGSKEW}	Package Skew ⁽¹⁾	XC7K70T	FBG484	108	ps	
			FBG676	135	ps	
		XC7K160T	FBG484	118	ps	
			FBG676	136	ps	
			FFG676	161	ps	
		XC7K325T	FBG676	146	ps	
			FFG676	154	ps	
			FBG900	163	ps	
			FFG900	161	ps	
		XC7K355T		FFG901	149	ps
		XC7K410T	FBG676	165	ps	
			FFG676	168	ps	
			FBG900	151	ps	
			FFG900	146	ps	
		XC7K420T	FFG901	149	ps	
			FFG1156	145	ps	
		XC7K480T	FFG901	149	ps	
			FFG1156	145	ps	
		XA7K160T		FFG676	161	ps
		XQ7K325T	RF676	154	ps	
RF900	161		ps			
XQ7K410T	RF676	168	ps			
	RF900	146	ps			

Notes:

1. These values represent the worst-case skew between any two SelectIO resources in the package: shortest delay to longest delay from die pad to ball.
2. Package delay information is available for these device/package combinations. This information can be used to deskew the package.

GTX Transceiver Specifications

GTX Transceiver DC Input and Output Levels

Table 54 summarizes the DC output specifications of the GTX transceivers in Kintex-7 FPGAs. Consult the *7 Series FPGAs GTX/GTH Transceivers User Guide* (UG476) for further details.

Table 54: GTX Transceiver DC Specifications

Symbol	DC Parameter	Conditions	Min	Typ	Max	Units
DV _{PPOUT}	Differential peak-to-peak output voltage ⁽¹⁾	Transmitter output swing is set to maximum setting	1000	–	–	mV
V _{CMOUTDC}	DC common mode output voltage.	Equation based	$V_{MGTAVTT} - DV_{PPOUT}/4$			mV
R _{OUT}	Differential output resistance		–	100	–	Ω
T _{OSKEW}	Transmitter output pair (TXP and TXN) intra-pair skew		–	2	12	ps
DV _{PPIN}	Differential peak-to-peak input voltage (external AC coupled)	>10.3125 Gb/s	150	–	1250	mV
		6.6 Gb/s to 10.3125 Gb/s	150	–	1250	mV
		≤ 6.6 Gb/s	150	–	2000	mV
V _{IN}	Single-ended input voltage ⁽²⁾	DC coupled V _{MGTAVTT} = 1.2V	–200	–	V _{MGTAVTT}	mV
V _{CMIN}	Common mode input voltage	DC coupled V _{MGTAVTT} = 1.2V	–	2/3 V _{MGTAVTT}	–	mV
R _{IN}	Differential input resistance		–	100	–	Ω
C _{EXT}	Recommended external AC coupling capacitor ⁽³⁾		–	100	–	nF

Notes:

1. The output swing and preemphasis levels are programmable using the attributes discussed in the *7 Series FPGAs GTX/GTH Transceivers User Guide* (UG476) and can result in values lower than reported in this table.
2. Voltage measured at the pin referenced to ground.
3. Other values can be used as appropriate to conform to specific protocols and standards.

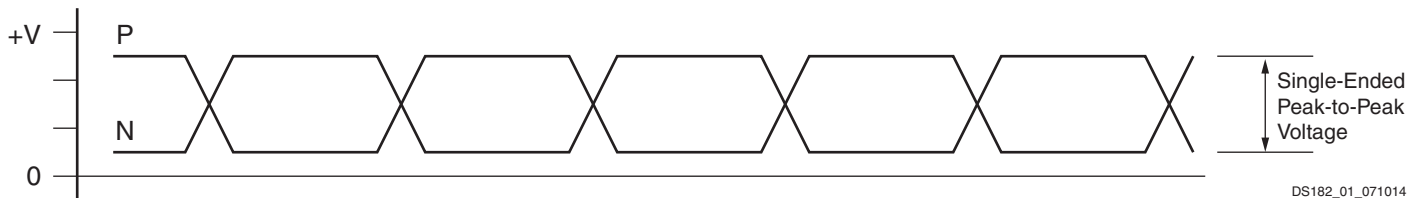

Figure 3: Single-Ended Peak-to-Peak Voltage

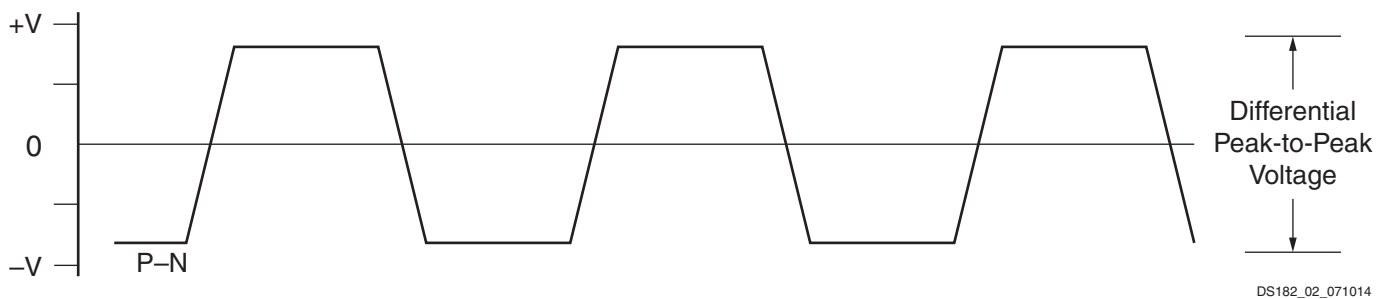

Figure 4: Differential Peak-to-Peak Voltage

Note: In Figure 4, differential peak-to-peak voltage = single-ended peak-to-peak voltage x 2.

Table 55 summarizes the DC specifications of the clock input of the GTX transceiver. Consult the *7 Series FPGAs GTX/GTH Transceivers User Guide (UG476)* for further details.

Table 55: GTX Transceiver Clock DC Input Level Specification

Symbol	DC Parameter	Min	Typ	Max	Units
V _{IDIFF}	Differential peak-to-peak input voltage	250	–	2000	mV
R _{IN}	Differential input resistance	–	100	–	Ω
C _{EXT}	Required external AC coupling capacitor	–	100	–	nF

GTX Transceiver Switching Characteristics

Consult the *7 Series FPGAs GTX/GTH Transceivers User Guide (UG476)* for further information.

Table 56: GTX Transceiver Performance

Symbol	Description	Output Divider	Speed Grade ⁽¹⁾								Units	
			-3 (1.0V)			-2 (1.0V) -2LE (1.0V) -2LI (0.95V)		-1 (1.0V) ⁽²⁾ -1M (1.0V) ⁽²⁾ -1LM (1.0V) ⁽²⁾ -1Q (1.0V) ⁽²⁾		-2LE (0.9V) ⁽³⁾		
			Package Type									
			FF	FBG484	FBG676 FBG900	FF RF FBG484	FBG676 FBG900	FF RF	FB	FF RF	FB	
F _{GTXMAX} ⁽⁴⁾	Maximum GTX transceiver data rate		12.5 ⁽⁵⁾	10.3125 ⁽⁶⁾	6.6	10.3125 ⁽⁶⁾	6.6	8.0	6.6	6.6	6.6	Gb/s
F _{GTXMIN} ⁽⁴⁾	Minimum GTX transceiver data rate		0.500	0.500	0.500	0.500	0.500	0.500	0.500	0.500	0.500	Gb/s
F _{GTXCRANGE}	CPLL line rate range	1	3.2–6.6								Gb/s	
		2	1.6–3.3								Gb/s	
		4	0.8–1.65								Gb/s	
		8	0.5–0.825								Gb/s	
		16	N/A								Gb/s	
F _{GTXQRANGE1}	QPLL line rate range 1	1	5.93–8.0	5.93–8.0	5.93–6.6	5.93–8.0	5.93–6.6	5.93–8.0	5.93–6.6	5.93–6.6	Gb/s	
		2	2.965–4.0			2.965–4.0		2.965–4.0		2.965–3.3		Gb/s
		4	1.4825–2.0			1.4825–2.0		1.4825–2.0		1.4825–1.65		Gb/s
		8	0.74125–1.0			0.74125–1.0		0.74125–1.0		0.74125–0.825		Gb/s
		16	N/A			N/A		N/A		N/A		Gb/s
F _{GTXQRANGE2}	QPLL line rate range 2 ⁽⁷⁾	1	9.8–12.5	9.8–10.3125	N/A	9.8–10.3125	N/A	N/A	N/A	N/A	Gb/s	
		2	4.9–6.25			4.9–5.15625		N/A		N/A		Gb/s
		4	2.45–3.125			2.45–2.578125		N/A		N/A		Gb/s
		8	1.225–1.5625			1.225–1.2890625		N/A		N/A		Gb/s
		16	0.6125–0.78125			0.6125–0.64453125		N/A		N/A		Gb/s
F _{GCPLL} RANGE	GTX transceiver CPLL frequency range		1.6–3.3			1.6–3.3		1.6–3.3		1.6–3.3		GHz
F _{GQPLL} RANGE1	GTX transceiver QPLL frequency range 1		5.93–8.0			5.93–8.0		5.93–8.0		5.93–6.6		GHz

Table 56: GTX Transceiver Performance (Cont'd)

Symbol	Description	Output Divider	Speed Grade ⁽¹⁾							Units		
			-3 (1.0V)		-2 (1.0V) -2LE (1.0V) -2LI (0.95V)		-1 (1.0V) ⁽²⁾ -1M (1.0V) ⁽²⁾ -1LM (1.0V) ⁽²⁾ -1Q (1.0V) ⁽²⁾		-2LE (0.9V) ⁽³⁾			
			Package Type									
			FF	FBG484	FBG676 FBG900	FF RF FBG484	FBG676 FBG900	FF RF	FB	FF RF	FB	
F _{GQPLL} RANGE2	GTX transceiver QPLL frequency range 2		9.8–12.5		9.8–10.3125		N/A		N/A		GHz	

Notes:

1. Voltages specified for speed grades are V_{CCINT}.
2. The -1 speed grade requires a 4-byte internal data width for operation above 5.0 Gb/s.
3. The -2LE (0.9V) speed grade requires a 4-byte internal data width for operation above 3.8 Gb/s.
4. Data rates between 8.0 Gb/s and 9.8 Gb/s are not available.
5. For line rates greater than 10.3125 Gb/s, V_{MGTAVCC} is 1.05V nominal (see Table 2).
6. The FBG484 package supports data rates greater than 6.6 Gb/s in the -2 and -3 speed grades (requires Vivado Design Suite 2017.1 or later).
7. For QPLL line rate range 2, the maximum line rate with the divider N set to 66 is 10.3125 Gb/s.

Table 57: GTX Transceiver Dynamic Reconfiguration Port (DRP) Switching Characteristics

Symbol	Description	Speed Grade					Units
		1.0V			0.95V	0.9V	
		-3	-2/-2LE	-1/-1M/-1LM/-1Q	-2LI	-2LE	
F _{GTXDRPCLK}	GTXDRPCLK maximum frequency	175.01	175.01	156.25	175.01	125.00	MHz

Table 58: GTX Transceiver Reference Clock Switching Characteristics

Symbol	Description	Conditions	All Speed Grades			Units
			Min	Typ	Max	
F _{GCLK}	Reference clock frequency range	-3 speed grade	60	–	700	MHz
		All other speed grades	60	–	670	MHz
T _{RCLK}	Reference clock rise time	20% – 80%	–	200	–	ps
T _{FCLK}	Reference clock fall time	80% – 20%	–	200	–	ps
T _{DCREF}	Reference clock duty cycle	Transceiver PLL only	40	50	60	%

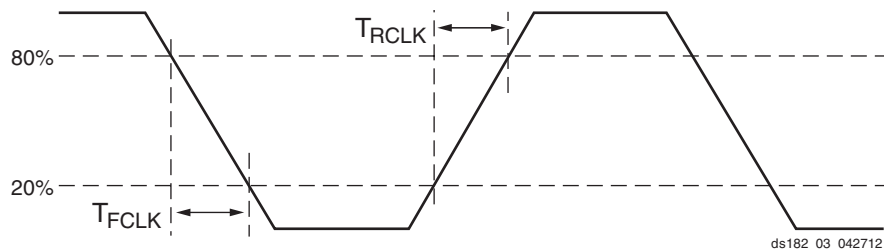

Figure 5: Reference Clock Timing Parameters

Table 59: GTX Transceiver PLL /Lock Time Adaptation

Symbol	Description	Conditions	All Speed Grades			Units
			Min	Typ	Max	
T _{LOCK}	Initial PLL lock		–	–	1	ms
T _{DLOCK}	Clock recovery phase acquisition and adaptation time for decision feedback equalizer (DFE).	After the PLL is locked to the reference clock, this is the time it takes to lock the clock data recovery (CDR) to the data present at the input.	–	50,000	37 x10 ⁶	UI
	Clock recovery phase acquisition and adaptation time for low-power mode (LPM) when the DFE is disabled.		–	50,000	2.3 x10 ⁶	UI

Table 60: GTX Transceiver User Clock Switching Characteristics⁽¹⁾⁽²⁾

Symbol	Description	Conditions	Speed Grade					Units
			1.0V			0.95V	0.9V	
			-3 ⁽³⁾	-2/-2LE ⁽³⁾	-1/-1M/-1LM/-1Q ⁽⁴⁾	-2LI	-2LE ⁽⁵⁾	
F _{TXOUT}	TXOUTCLK maximum frequency		412.500	412.500	312.500	412.500	237.500	MHz
F _{RXOUT}	RXOUTCLK maximum frequency		412.500	412.500	312.500	412.500	237.500	MHz
F _{TXIN}	TXUSRCLK maximum frequency	16-bit data path	412.500	412.500	312.500	412.500	237.500	MHz
		32-bit data path	390.625	322.266	250.000	322.266	206.250	MHz
F _{RXIN}	RXUSRCLK maximum frequency	16-bit data path	412.500	412.500	312.500	412.500	237.500	MHz
		32-bit data path	390.625	322.266	250.000	322.266	206.250	MHz
F _{TXIN2}	TXUSRCLK2 maximum frequency	16-bit data path	412.500	412.500	312.500	412.500	237.500	MHz
		32-bit data path	390.625	322.266	250.000	322.266	206.250	MHz
		64-bit data path	195.313	161.133	125.000	161.133	103.125	MHz
F _{RXIN2}	RXUSRCLK2 maximum frequency	16-bit data path	412.500	412.500	312.500	412.500	237.500	MHz
		32-bit data path	390.625	322.266	250.000	322.266	206.250	MHz
		64-bit data path	195.313	161.133	125.000	161.133	103.125	MHz

Notes:

1. Clocking must be implemented as described in the 7 Series FPGAs GTX/GTH Transceivers User Guide (UG476).
2. These frequencies are not supported for all possible transceiver configurations.
3. For speed grades -3, -2, -2LE (1.0V), -2LI (0.95V), a 16-bit data path can only be used for speeds less than 6.6 Gb/s.
4. For speed grade -1, a 16-bit data path can only be used for speeds less than 5.0 Gb/s.
5. For speed grade -2LE (0.9V), a 16-bit data path can only be used for speeds less than 3.8 Gb/s.

Table 61: GTX Transceiver Transmitter Switching Characteristics

Symbol	Description	Condition	Min	Typ	Max	Units
F _{GTXTX}	Serial data rate range		0.500	–	F _{GTXTXMAX}	Gb/s
T _{RTX}	TX Rise time	20%–80%	–	40	–	ps
T _{FTX}	TX Fall time	80%–20%	–	40	–	ps
T _{LLSKEW}	TX lane-to-lane skew ⁽¹⁾		–	–	500	ps
V _{TXOOBVDDP}	Electrical idle amplitude		–	–	15	mV
T _{TXOOBTRANSITION}	Electrical idle transition time		–	–	140	ns
T _{J12.5}	Total Jitter ⁽²⁾⁽⁴⁾	12.5 Gb/s	–	–	0.28	UI
D _{J12.5}	Deterministic Jitter ⁽²⁾⁽⁴⁾		–	–	0.17	UI
T _{J11.18}	Total Jitter ⁽²⁾⁽⁴⁾	11.18 Gb/s	–	–	0.28	UI
D _{J11.18}	Deterministic Jitter ⁽²⁾⁽⁴⁾		–	–	0.17	UI

Table 61: GTX Transceiver Transmitter Switching Characteristics (Cont'd)

Symbol	Description	Condition	Min	Typ	Max	Units
TJ _{10.3125}	Total Jitter ⁽²⁾⁽⁴⁾	10.3125 Gb/s	–	–	0.28	UI
DJ _{10.3125}	Deterministic Jitter ⁽²⁾⁽⁴⁾		–	–	0.17	UI
TJ _{9.953}	Total Jitter ⁽²⁾⁽⁴⁾	9.953 Gb/s	–	–	0.28	UI
DJ _{9.953}	Deterministic Jitter ⁽²⁾⁽⁴⁾		–	–	0.17	UI
TJ _{9.8}	Total Jitter ⁽²⁾⁽⁴⁾	9.8 Gb/s	–	–	0.28	UI
DJ _{9.8}	Deterministic Jitter ⁽²⁾⁽⁴⁾		–	–	0.17	UI
TJ _{8.0}	Total Jitter ⁽²⁾⁽⁴⁾	8.0 Gb/s	–	–	0.30	UI
DJ _{8.0}	Deterministic Jitter ⁽²⁾⁽⁴⁾		–	–	0.15	UI
TJ _{6.6_QPLL}	Total Jitter ⁽²⁾⁽⁴⁾	6.6 Gb/s	–	–	0.28	UI
DJ _{6.6_QPLL}	Deterministic Jitter ⁽²⁾⁽⁴⁾		–	–	0.17	UI
TJ _{6.6_CPLL}	Total Jitter ⁽³⁾⁽⁴⁾	6.6 Gb/s	–	–	0.30	UI
DJ _{6.6_CPLL}	Deterministic Jitter ⁽³⁾⁽⁴⁾		–	–	0.15	UI
TJ _{5.0}	Total Jitter ⁽³⁾⁽⁴⁾	5.0 Gb/s	–	–	0.30	UI
DJ _{5.0}	Deterministic Jitter ⁽³⁾⁽⁴⁾		–	–	0.15	UI
TJ _{4.25}	Total Jitter ⁽³⁾⁽⁴⁾	4.25 Gb/s	–	–	0.30	UI
DJ _{4.25}	Deterministic Jitter ⁽³⁾⁽⁴⁾		–	–	0.15	UI
TJ _{3.75}	Total Jitter ⁽³⁾⁽⁴⁾	3.75 Gb/s	–	–	0.30	UI
DJ _{3.75}	Deterministic Jitter ⁽³⁾⁽⁴⁾		–	–	0.15	UI
TJ _{3.2}	Total Jitter ⁽³⁾⁽⁴⁾	3.20 Gb/s ⁽⁵⁾	–	–	0.2	UI
DJ _{3.2}	Deterministic Jitter ⁽³⁾⁽⁴⁾		–	–	0.1	UI
TJ _{3.2L}	Total Jitter ⁽³⁾⁽⁴⁾	3.20 Gb/s ⁽⁶⁾	–	–	0.32	UI
DJ _{3.2L}	Deterministic Jitter ⁽³⁾⁽⁴⁾		–	–	0.16	UI
TJ _{2.5}	Total Jitter ⁽³⁾⁽⁴⁾	2.5 Gb/s ⁽⁷⁾	–	–	0.20	UI
DJ _{2.5}	Deterministic Jitter ⁽³⁾⁽⁴⁾		–	–	0.08	UI
TJ _{1.25}	Total Jitter ⁽³⁾⁽⁴⁾	1.25 Gb/s ⁽⁸⁾	–	–	0.15	UI
DJ _{1.25}	Deterministic Jitter ⁽³⁾⁽⁴⁾		–	–	0.06	UI
TJ ₅₀₀	Total Jitter ⁽³⁾⁽⁴⁾	500 Mb/s	–	–	0.1	UI
DJ ₅₀₀	Deterministic Jitter ⁽³⁾⁽⁴⁾		–	–	0.03	UI

Notes:

- Using same REFCLK input with TX phase alignment enabled for up to 12 consecutive transmitters (three fully populated GTX Quads).
- Using QPLL_FBDIV = 40, 20-bit internal data width. These values are NOT intended for protocol specific compliance determinations.
- Using CPLL_FBDIV = 2, 20-bit internal data width. These values are NOT intended for protocol specific compliance determinations.
- All jitter values are based on a bit-error ratio of 1e⁻¹².
- CPLL frequency at 3.2 GHz and TXOUT_DIV = 2.
- CPLL frequency at 1.6 GHz and TXOUT_DIV = 1.
- CPLL frequency at 2.5 GHz and TXOUT_DIV = 2.
- CPLL frequency at 2.5 GHz and TXOUT_DIV = 4.

Table 62: GTX Transceiver Receiver Switching Characteristics

Symbol	Description		Min	Typ	Max	Units
F _{GTXR}	Serial data rate		0.500	–	F _{GTXMAX}	Gb/s
T _{RXELECIDLE}	Time for RXELECIDLE to respond to loss or restoration of data		–	10	–	ns
RX _{OOBVDDPP}	OOB detect threshold peak-to-peak		60	–	150	mV
RX _{SST}	Receiver spread-spectrum tracking ⁽¹⁾	Modulated @ 33 KHz	–5000	–	0	ppm
RX _{RL}	Run length (CID)		–	–	512	UI
RX _{PPMTOL}	Data/REFCLK PPM offset tolerance	Bit rates ≤ 6.6 Gb/s	–1250	–	1250	ppm
		Bit rates > 6.6 Gb/s and ≤ 8.0 Gb/s	–700	–	700	ppm
		Bit rates > 8.0 Gb/s	–200	–	200	ppm
SJ Jitter Tolerance⁽²⁾						
JT_SJ _{12.5}	Sinusoidal Jitter (QPLL) ⁽³⁾	12.5 Gb/s	0.3	–	–	UI
JT_SJ _{11.18}	Sinusoidal Jitter (QPLL) ⁽³⁾	11.18 Gb/s	0.3	–	–	UI
JT_SJ _{10.32}	Sinusoidal Jitter (QPLL) ⁽³⁾	10.32 Gb/s	0.3	–	–	UI
JT_SJ _{9.95}	Sinusoidal Jitter (QPLL) ⁽³⁾	9.95 Gb/s	0.3	–	–	UI
JT_SJ _{9.8}	Sinusoidal Jitter (QPLL) ⁽³⁾	9.8 Gb/s	0.3	–	–	UI
JT_SJ _{8.0}	Sinusoidal Jitter (QPLL) ⁽³⁾	8.0 Gb/s	0.44	–	–	UI
JT_SJ _{6.6_QPLL}	Sinusoidal Jitter (QPLL) ⁽³⁾	6.6 Gb/s	0.48	–	–	UI
JT_SJ _{6.6_CPLL}	Sinusoidal Jitter (CPLL) ⁽³⁾	6.6 Gb/s	0.44	–	–	UI
JT_SJ _{5.0}	Sinusoidal Jitter (CPLL) ⁽³⁾	5.0 Gb/s	0.44	–	–	UI
JT_SJ _{4.25}	Sinusoidal Jitter (CPLL) ⁽³⁾	4.25 Gb/s	0.44	–	–	UI
JT_SJ _{3.75}	Sinusoidal Jitter (CPLL) ⁽³⁾	3.75 Gb/s	0.44	–	–	UI
JT_SJ _{3.2}	Sinusoidal Jitter (CPLL) ⁽³⁾	3.2 Gb/s ⁽⁴⁾	0.45	–	–	UI
JT_SJ _{3.2L}	Sinusoidal Jitter (CPLL) ⁽³⁾	3.2 Gb/s ⁽⁵⁾	0.45	–	–	UI
JT_SJ _{2.5}	Sinusoidal Jitter (CPLL) ⁽³⁾	2.5 Gb/s ⁽⁶⁾	0.5	–	–	UI
JT_SJ _{1.25}	Sinusoidal Jitter (CPLL) ⁽³⁾	1.25 Gb/s ⁽⁷⁾	0.5	–	–	UI
JT_SJ ₅₀₀	Sinusoidal Jitter (CPLL) ⁽³⁾	500 Mb/s	0.4	–	–	UI
SJ Jitter Tolerance with Stressed Eye⁽²⁾						
JT_TJSE _{3.2}	Total Jitter with Stressed Eye ⁽⁸⁾	3.2 Gb/s	0.70	–	–	UI
JT_TJSE _{6.6}		6.6 Gb/s	0.70	–	–	UI
JT_SJSE _{3.2}	Sinusoidal Jitter with Stressed Eye ⁽⁸⁾	3.2 Gb/s	0.1	–	–	UI
JT_SJSE _{6.6}		6.6 Gb/s	0.1	–	–	UI

Notes:

- Using RXOUT_DIV = 1, 2, and 4.
- All jitter values are based on a bit error ratio of 1e⁻¹².
- The frequency of the injected sinusoidal jitter is 10 MHz.
- CPLL frequency at 3.2 GHz and RXOUT_DIV = 2.
- CPLL frequency at 1.6 GHz and RXOUT_DIV = 1.
- CPLL frequency at 2.5 GHz and RXOUT_DIV = 2.
- CPLL frequency at 2.5 GHz and RXOUT_DIV = 4.
- Composite jitter with RX in LPM or DFE mode.

GTX Transceiver Protocol Jitter Characteristics

For Table 63 through Table 68, the 7 Series FPGAs GTX/GTH Transceivers User Guide (UG476) contains recommended settings for optimal usage of protocol specific characteristics.

Table 63: Gigabit Ethernet Protocol Characteristics

Description	Line Rate (Mb/s)	Min	Max	Units
Gigabit Ethernet Transmitter Jitter Generation				
Total transmitter jitter (T_TJ)	1250	–	0.24	UI
Gigabit Ethernet Receiver High Frequency Jitter Tolerance				
Total receiver jitter tolerance	1250	0.749	–	UI

Table 64: XAUI Protocol Characteristics

Description	Line Rate (Mb/s)	Min	Max	Units
XAUI Transmitter Jitter Generation				
Total transmitter jitter (T_TJ)	3125	–	0.35	UI
XAUI Receiver High Frequency Jitter Tolerance				
Total receiver jitter tolerance	3125	0.65	–	UI

Table 65: PCI Express Protocol Characteristics⁽¹⁾

Standard	Description	Line Rate (Mb/s)	Min	Max	Units	
PCI Express Transmitter Jitter Generation						
PCI Express Gen 1	Total transmitter jitter	2500	–	0.25	UI	
PCI Express Gen 2	Total transmitter jitter	5000	–	0.25	UI	
PCI Express Gen 3	Total transmitter jitter uncorrelated	8000	–	31.25	ps	
	Deterministic transmitter jitter uncorrelated		–	12	ps	
PCI Express Receiver High Frequency Jitter Tolerance						
PCI Express Gen 1	Total receiver jitter tolerance	2500	0.65	–	UI	
PCI Express Gen 2 ⁽²⁾	Receiver inherent timing error	5000	0.40	–	UI	
	Receiver inherent deterministic timing error		0.30	–	UI	
PCI Express Gen 3	Receiver sinusoidal jitter tolerance	0.03 MHz–1.0 MHz	8000	1.00	–	UI
		1.0 MHz–10 MHz		Note 3	–	UI
		10 MHz–100 MHz		0.10	–	UI

Notes:

1. Tested per card electromechanical (CEM) methodology.
2. Using common REFCLK.
3. Between 1 MHz and 10 MHz the minimum sinusoidal jitter roll-off with a slope of 20dB/decade.

Table 66: CEI-6G and CEI-11G Protocol Characteristics

Description	Line Rate (Mb/s)	Interface	Min	Max	Units
CEI-6G Transmitter Jitter Generation					
Total transmitter jitter ⁽¹⁾	4976–6375	CEI-6G-SR	–	0.3	UI
		CEI-6G-LR	–	0.3	UI
CEI-6G Receiver High Frequency Jitter Tolerance					
Total receiver jitter tolerance ⁽¹⁾	4976–6375	CEI-6G-SR	0.6	–	UI
		CEI-6G-LR	0.95	–	UI
CEI-11G Transmitter Jitter Generation					
Total transmitter jitter ⁽²⁾	9950–11100	CEI-11G-SR	–	0.3	UI
		CEI-11G-LR/MR	–	0.3	UI
CEI-11G Receiver High Frequency Jitter Tolerance					
Total receiver jitter tolerance ⁽²⁾	9950–11100	CEI-11G-SR	0.65	–	UI
		CEI-11G-MR	0.65	–	UI
		CEI-11G-LR	0.825	–	UI

Notes:

1. Tested at most commonly used line rate of 6250 Mb/s using 390.625 MHz reference clock.
2. Tested at line rate of 9950 Mb/s using 155.46875 MHz reference clock and 11100 Mb/s using 173.4375 MHz reference clock.

Table 67: SFP+ Protocol Characteristics

Description	Line Rate (Mb/s)	Min	Max	Units
SFP+ Transmitter Jitter Generation				
Total transmitter jitter	9830.40 ⁽¹⁾	–	0.28	UI
	9953.00			
	10312.50			
	10518.75			
	11100.00			
SFP+ Receiver Frequency Jitter Tolerance				
Total receiver jitter tolerance	9830.40 ⁽¹⁾	0.7	–	UI
	9953.00			
	10312.50			
	10518.75			
	11100.00			

Notes:

1. Line rated used for CPRI over SFP+ applications.

Table 68: CPRI Protocol Characteristics

Description	Line Rate (Mb/s)	Min	Max	Units
CPRI Transmitter Jitter Generation				
Total transmitter jitter	614.4	–	0.35	UI
	1228.8	–	0.35	UI
	2457.6	–	0.35	UI
	3072.0	–	0.35	UI
	4915.2	–	0.3	UI
	6144.0	–	0.3	UI
	9830.4	–	Note 1	UI
CPRI Receiver Frequency Jitter Tolerance				
Total receiver jitter tolerance	614.4	0.65	–	UI
	1228.8	0.65	–	UI
	2457.6	0.65	–	UI
	3072.0	0.65	–	UI
	4915.2	0.95	–	UI
	6144.0	0.95	–	UI
	9830.4	Note 1	–	UI

Notes:

1. Tested per SFP+ specification, see Table 67.

Integrated Interface Block for PCI Express Designs Switching Characteristics

More information and documentation on solutions for PCI Express designs can be found at: www.xilinx.com/products/technology/pci-express.html

Table 69: Maximum Performance for PCI Express Designs⁽¹⁾

Symbol	Description	Speed Grade					Units
		1.0V			0.95V	0.9V	
		-3	-2/-2LE	-1/-1M/-1LM/-1Q	-2LI	-2LE	
F _{PIPECLK}	Pipe clock maximum frequency	250.00	250.00	250.00	250.00	250.00	MHz
F _{USERCLK}	User clock maximum frequency	500.00 ⁽¹⁾	500.00 ⁽¹⁾	250.00	500.00 ⁽¹⁾	250.00	MHz
F _{USERCLK2}	User clock 2 maximum frequency	250.00	250.00	250.00	250.00	250.00	MHz
F _{DRPCLK}	DRP clock maximum frequency	250.00	250.00	250.00	250.00	250.00	MHz

Notes:

1. Refer to the 7 Series FPGAs Integrated Block for PCI Express Product Guide (PG054) for specific supported core configurations.

XADC Specifications

Table 70: XADC Specifications

Parameter	Symbol	Comments/Conditions	Min	Typ	Max	Units
$V_{CCADC} = 1.8V \pm 5\%$, $V_{REFP} = 1.25V$, $V_{REFN} = 0V$, $ADCCLK = 26\text{ MHz}$, $T_j = -40^\circ\text{C}$ to 100°C , Typical values at $T_j = +40^\circ\text{C}$						
ADC Accuracy⁽¹⁾						
Resolution			12	–	–	Bits
Integral Nonlinearity ⁽²⁾	INL		–	–	± 3	LSBs
Differential Nonlinearity	DNL	No missing codes, guaranteed monotonic	–	–	± 1	LSBs
Offset Error		Offset calibration enabled	–	–	± 6	LSBs
Gain Error		Gain calibration disabled	–	–	± 0.5	%
Offset Matching		Offset calibration enabled	–	–	4	LSBs
Gain Matching		Gain calibration disabled	–	–	0.3	%
Sample Rate			–	–	1	MS/s
Signal to Noise Ratio ⁽²⁾	SNR	$F_{SAMPLE} = 500\text{KS/s}$, $F_{IN} = 20\text{KHz}$	60	–	–	dB
RMS Code Noise		External 1.25V reference	–	–	2	LSBs
		On-chip reference	–	3	–	LSBs
Total Harmonic Distortion ⁽²⁾	THD	$F_{SAMPLE} = 500\text{KS/s}$, $F_{IN} = 20\text{KHz}$	–	70	–	dB
ADC Accuracy at Extended Temperatures						
Resolution		$T_j = -55^\circ\text{C}$ to 125°C	10	–	–	Bits
Integral Nonlinearity ⁽²⁾	INL	$T_j = -55^\circ\text{C}$ to 125°C	–	–	± 1	LSB (at 10 bits)
Differential Nonlinearity	DNL	No missing codes, guaranteed monotonic, $T_j = -55^\circ\text{C}$ to 125°C	–	–	± 1	
Analog Inputs⁽³⁾						
ADC Input Ranges		Unipolar operation	0	–	1	V
		Bipolar operation	–0.5	–	+0.5	V
		Unipolar common mode range (FS input)	0	–	+0.5	V
		Bipolar common mode range (FS input)	+0.5	–	+0.6	V
Maximum External Channel Input Ranges		Adjacent channels set within these ranges should not corrupt measurements on adjacent channels	–0.1	–	V_{CCADC}	V
Auxiliary Channel Full Resolution Bandwidth	FRBW		250	–	–	KHz
On-Chip Sensors						
Temperature Sensor Error		$T_j = -40^\circ\text{C}$ to 100°C	–	–	± 4	$^\circ\text{C}$
		$T_j = -55^\circ\text{C}$ to $+125^\circ\text{C}$	–	–	± 6	$^\circ\text{C}$
		$T_j = -40^\circ\text{C}$ to $+125^\circ\text{C}$				$^\circ\text{C}$
Supply Sensor Error		Measurement range of $V_{CCAUX} 1.8V \pm 5\%$ $T_j = -40^\circ\text{C}$ to $+100^\circ\text{C}$	–	–	± 1	%
		Measurement range of $V_{CCAUX} 1.8V \pm 5\%$ $T_j = -55^\circ\text{C}$ to $+125^\circ\text{C}$	–	–	± 2	%
Conversion Rate⁽⁴⁾						
Conversion Time - Continuous	t_{CONV}	Number of ADCCLK cycles	26	–	32	Cycles
Conversion Time - Event	t_{CONV}	Number of CLK cycles	–	–	21	Cycles
DRP Clock Frequency	DCLK	DRP clock frequency	8	–	250	MHz

Table 70: XADC Specifications (Cont'd)

Parameter	Symbol	Comments/Conditions	Min	Typ	Max	Units
ADC Clock Frequency	ADCCLK	Derived from DCLK	1	–	26	MHz
DCLK Duty Cycle			40	–	60	%
XADC Reference⁽⁵⁾						
External Reference	V _{REFP}	Externally supplied reference voltage	1.20	1.25	1.30	V
On-Chip Reference		Ground V _{REFP} pin to AGND, T _j = –40°C to 100°C	1.2375	1.25	1.2625	V

Notes:

- Offset and gain errors are removed by enabling the XADC automatic gain calibration feature. The values are specified for when this feature is enabled.
- Only specified for bitstream option XADCEnhancedLinearity = ON.
- For a detailed description, see the ADC chapter in the *7 Series FPGAs and Zynq-7000 SoC XADC Dual 12-Bit 1 MSPS Analog-to-Digital Converter User Guide (UG480)*.
- For a detailed description, see the Timing chapter in the *7 Series FPGAs and Zynq-7000 SoC XADC Dual 12-Bit 1 MSPS Analog-to-Digital Converter User Guide (UG480)*.
- Any variation in the reference voltage from the nominal V_{REFP} = 1.25V and V_{REFN} = 0V will result in a deviation from the ideal transfer function. This also impacts the accuracy of the internal sensor measurements (i.e., temperature and power supply). However, for external ratiometric type applications allowing reference to vary by ±4% is permitted. On-chip reference variation is ±1%.

Configuration Switching Characteristics

Table 71: Configuration Switching Characteristics

Symbol	Description	Speed Grade					Units
		1.0V			0.95V	0.9V	
		-3	-2/-2LE	-1/-1M/ -1LM/-1Q	-2LI	-2LE	
Power-up Timing Characteristics							
T _{PL} ⁽¹⁾	Program latency	5	5	5	5	5	ms, Max
T _{POR} ⁽¹⁾	Power-on reset (50 ms ramp rate time)	10/50	10/50	10/50	10/50	10/50	ms, Min/Max
	Power-on reset (1 ms ramp rate time)	10/35	10/35	10/35	10/35	10/35	ms, Min/Max
T _{PROGRAM}	Program pulse width	250	250	250	250	250	ns, Min
CCLK Output (Master Mode)							
T _{ICCK}	Master CCLK output delay	150	150	150	150	150	ns, Min
T _{MCCKL}	Master CCLK clock Low time duty cycle	40/60	40/60	40/60	40/60	40/60	%, Min/Max
T _{MCCKH}	Master CCLK clock High time duty cycle	40/60	40/60	40/60	40/60	40/60	%, Min/Max
F _{MCCK}	Master CCLK frequency	100.00	100.00	100.00	100.00	70.00	MHz, Max
	Master CCLK frequency for AES encrypted x16	50.00	50.00	50.00	50.00	35.00	MHz, Max
F _{MCCK_START}	Master CCLK frequency at start of configuration	3.00	3.00	3.00	3.00	3.00	MHz, Typ
F _{MCCKTOL}	Frequency tolerance, master mode with respect to nominal CCLK	±50	±50	±50	±50	±50	%, Max
CCLK Input (Slave Modes)							
T _{SCKL}	Slave CCLK clock minimum Low time	2.50	2.50	2.50	2.50	2.50	ns, Min
T _{SCKH}	Slave CCLK clock minimum High time	2.50	2.50	2.50	2.50	2.50	ns, Min
F _{SCK}	Slave CCLK frequency	100.00	100.00	100.00	100.00	70.00	MHz, Max
EMCCLK Input (Master Mode)							
T _{EMCCKL}	External master CCLK Low time	2.50	2.50	2.50	2.50	2.50	ns, Min

Table 71: Configuration Switching Characteristics (Cont'd)

Symbol	Description	Speed Grade					Units
		1.0V			0.95V	0.9V	
		-3	-2/-2LE	-1/-1M/ -1LM/-1Q	-2LI	-2LE	
T _{EMCCKH}	External master CCLK High time	2.50	2.50	2.50	2.50	2.50	ns, Min
F _{EMCCK}	External master CCLK frequency	100.00	100.00	100.00	100.00	70.00	MHz, Max
Internal Configuration Access Port							
F _{ICAPCK}	Internal configuration access port (ICAPE2)	100.00	100.00	100.00	100.00	70.00	MHz, Max
Master/Slave Serial Mode Programming Switching							
T _{DCCK} / T _{CCKD}	DIN Setup/Hold	4.00/0.00	4.00/0.00	4.00/0.00	4.00/0.00	5.00/0.00	ns, Min
T _{CCO}	DOUT clock to out	8.00	8.00	8.00	8.00	9.00	ns, Max
SelectMAP Mode Programming Switching							
T _{SMDCCK} / T _{SMCCKD}	D[31:00] Setup/Hold	4.00/0.00	4.00/0.00	4.00/0.00	4.00/0.00	4.50/0.00	ns, Min
T _{SMCSCCK} / T _{SMCCKCS}	CSI_B Setup/Hold	4.00/0.00	4.00/0.00	4.00/0.00	4.00/0.00	5.00/0.00	ns, Min
T _{SMWCCK} / T _{SMCCKW}	RDWR_B Setup/Hold	10.00/0.00	10.00/0.00	10.00/0.00	10.00/0.00	12.00/0.00	ns, Min
T _{SMCKCSO}	CSO_B clock to out (330Ω pull-up resistor required)	7.00	7.00	7.00	7.00	8.00	ns, Max
T _{SMCO}	D[31:00] clock to out in readback	8.00	8.00	8.00	8.00	10.00	ns, Max
F _{RBCCK}	Readback frequency	100.00	100.00	100.00	100.00	70.00	MHz, Max
Boundary-Scan Port Timing Specifications							
T _{TAPTCK} / T _{TCKTAP}	TMS and TDI Setup/Hold	3.00/2.00	3.00/2.00	3.00/2.00	3.00/2.00	3.00/2.00	ns, Min
T _{TCKTDO}	TCK falling edge to TDO output	7.00	7.00	7.00	7.00	8.50	ns, Max
F _{TCK}	TCK frequency	66.00	66.00	66.00	66.00	50.00	MHz, Max
BPI Flash Master Mode Programming Switching							
T _{BPICCO} ⁽²⁾	A[28:00], RS[1:0], FCS_B, FOE_B, FWE_B, ADV_B clock to out	8.50	8.50	8.50	8.50	10.00	ns, Max
T _{BPIDCC} / T _{BPICCD}	D[15:00] Setup/Hold	4.00/0.00	4.00/0.00	4.00/0.00	4.00/0.00	4.50/0.00	ns, Min
SPI Flash Master Mode Programming Switching							
T _{SPIDCC} / T _{SPICCD}	D[03:00] Setup/Hold	3.00/0.00	3.00/0.00	3.00/0.00	3.00/0.00	3.00/0.00	ns, Min
T _{SPICCM}	MOSI clock to out	8.00	8.00	8.00	8.00	9.00	ns, Max
T _{SPICFC}	FCS_B clock to out	8.00	8.00	8.00	8.00	9.00	ns, Max
STARTUPE2 Ports							
T _{USRCCLKO}	STARTUPE2 USRCCLKO input to CCLK output	0.50/6.00	0.50/6.70	0.50/7.50	0.50/6.70	0.50/7.50	ns, Min/Max
F _{CFGMCLK}	STARTUPE2 CFGMCLK output frequency	65.00	65.00	65.00	65.00	65.00	MHz, Typ
F _{CFGMCLKTOL}	STARTUPE2 CFGMCLK output frequency tolerance	±50	±50	±50	±50	±50	%, Max

Table 71: Configuration Switching Characteristics (Cont'd)

Symbol	Description	Speed Grade					Units
		1.0V			0.95V	0.9V	
		-3	-2/-2LE	-1/-1M/ -1LM/-1Q	-2LI	-2LE	
Device DNA Access Port							
F _{DNACK}	DNA access port (DNA_PORT)	100.00	100.00	100.00	100.00	70.00	MHz, Max

Notes:

- To support longer delays in configuration, use the design solutions described in the *7 Series FPGA Configuration User Guide* (UG470).
- Only during configuration, the last edge is determined by a weak pull-up/pull-down resistor in the I/O.

eFUSE Programming Conditions

Table 72 lists the programming conditions specifically for eFUSE. For more information, see the *7 Series FPGA Configuration User Guide* (UG470).

Table 72: eFUSE Programming Conditions⁽¹⁾

Symbol	Description	Min	Typ	Max	Units
I _{FS}	V _{CCAUX} supply current	–	–	115	mA
t _j	Temperature range	15	–	125	°C

Notes:

- The FPGA must not be configured during eFUSE programming.

Revision History

The following table shows the revision history for this document:

Date	Version	Description
03/01/2011	1.0	Initial Xilinx release.
04/01/2011	1.1	Added the XC7K355T, XC7K420T, and XC7K480T devices throughout data sheet. Added the extended temperature range discussion to page 1. Updated V _{CCAUX_IO} in Table 2. Edits to clarify Power-On/Off Power Supply Sequencing power sequencing discussion. Added I _{CCAUX_IO} and I _{CBBRAM} to Table 6 and Table 7. Updated MMCM_F _{INDUTY} and added F _{INJITTER} , T _{OUTJITTER} , T _{EXTFDVAR} , and Note 3 to Table 41. Removed the SBG324 package from Table 53. Updated the Notice of Disclaimer.
10/04/2011	1.2	Replaced -1L with -2L throughout this data sheet. Updated Min/Max values and removed Note 5 from Table 2. Clarified Power-On/Off Power Supply Sequencing power sequencing discussion including adding T _{VCCO2VCCAUX} to Table 8. Updated V _{ICM} in Table 12 and Table 13. Added Note 1 to table 12. Updated Table 72 including adding Note 1. Added Absolute Maximum Ratings for GTX Transceivers. Revised the reference clock maximum frequency (F _{GCLK}) in Table 58. Added Table 60. Added LVTTTL and removed SSTL135_II and SSTL15_II specifications from Table 20. Removed HSTL_III from Table 21. Removed the I/O Standard Adjustment Measurement Methodology section. Use IBIS for more accurate information and measurements. Updated T _{IDELAYPAT_JIT} in Table 29. Added T _{AS} /T _{AH} to Table 31. Added T _{RDCK_DI_WF_NC} /T _{RCKD_DI_WF_NC} and T _{RDCK_DI_RF} /T _{RCKD_DI_RF} to Table 34. Completely updated Table 71. Updated the AC Switching Characteristics in Table 20, Table 21, Table 22, Table 25, Table 26, Table 27, Table 29 through Table 41, Table 43 through Table 40, and Table 67.
11/03/2011	1.3	Revised the V _{OCM} specification in Table 12. Updated the AC Switching Characteristics based upon the ISE 13.3 v1.02 speed specification throughout document including Table 20 and Table 21. Added MMCM_T _{FBDELAY} while adding MMCM_ to the symbol names of a few specifications in Table 41 and PLL to the symbol names in Table 42. In Table 43 through Table 50, updated the pin-to-pin descriptions with the SSTL15 standard. Updated units in Table 52.

Date	Version	Description
02/13/2012	1.4	<p>Updated summary description on page 1. In Table 2, revised V_{CCO} for the 3.3V HR I/O banks and updated T_j. Added typical values to Table 3. Updated the notes in Table 6. Added MGTAVCC, MGTAVTT, and MGTVCCAUX power supply ramp times to Table 8. Rearranged Table 9, added Mobile_DDR, HSTL_I_18, HSTL_II_18, HSUL_12, SSTL135_R, SSTL15_R, and SSTL12 and removed DIFF_SSTL135, DIFF_SSTL18_I, DIFF_SSTL18_II, DIFF_HSTL_I, and DIFF_HSTL_II. Added Table 10 and Table 11. Revised the specifications in Table 12 and Table 13. Updated the eFUSE Programming Conditions section and removed the endurance table. Added the IO_FIFO Switching Characteristics table. Revised I_{CCADC} and updated Note 1 in Table 70. Revised DDR LVDS transmitter data width in Table 17. Updated the AC Switching Characteristics based upon the ISE 13.4 v1.03 speed specification throughout document. Removed notes from Table 31 as they are no longer applicable. Updated specifications in Table 71. Updated Note 1 in Table 40.</p> <p>In the GTX Transceiver DC Input and Output Levels section: Revised V_{IN}, and added I_{DCIN} and I_{DCOUT} to Table 54. Added Note 7 to Table 56. In Table 58, revised F_{GCLK}, removed T_{PHASE}, and added T_{DLOCK}. Revised specifications and added Note 2 to Table 60. Added Table 61 and Table 62 along with GTX Transceiver Protocol Jitter Characteristics in Table 63 through Table 68.</p>
05/23/2012	1.5	<p>Reorganized entire data sheet including adding Table 47 and Table 51.</p> <p>Updated T_{SOL} in Table 1. Updated I_{BATT} and added R_{IN_TERM} to Table 3. Added values to Table 6 and Table 7. Updated Power-On/Off Power Supply Sequencing, page 7 with regards to GTX transceivers. Updated many parameters in Table 9 including SSTL135 and SSTL135_R. Removed V_{OX} column and added DIFF_HSUL_12 to Table 11. Updated V_{OL} in Table 12. Updated Table 17 and removed notes 2 and 3. Updated Table 18.</p> <p>Updated the AC Switching Characteristics based upon the ISE 14.1 v1.04 for the -3, -2, -2L (1.0V), -1, and -2L (0.9V) speed specifications throughout the document.</p> <p>In Table 34, updated Reset Delays section including Note 10 and Note 11. Added data for T_{LOCK} and T_{DLOCK} in Table 58. Updated many of the XADC specifications in Table 70 and added Note 2. Updated and moved Dynamic Reconfiguration Port (DRP) for MMCM Before and After DCLK section from Table 71 to Table 41 and Table 42.</p>
07/25/2012	1.6	<p>Updated the descriptions, changed V_{IN} and Note 2 and added Note 4 in Table 1. In Table 2, changed descriptions and notes, removed Note 7, changed GTX transceiver parameters and values and added Note 12. Updated parameters in Table 3. Added Table 4 and Table 5.</p> <p>Changed the typical values for many of the devices in Table 7. Updated LVCMOS12 and the SSTLs in Table 9. Updated many of the specifications in Table 10 and Table 11.</p> <p>Updated speed specification to v1.06 (-3, -2, -2L(1.0V), -1) and v1.05 (-2L(0.9V)) with appropriate changes to Table 15 and Table 16 including production release of the XC7K325T and the XC7K410T in the -2, -2L(1.0V), and -1 speed designations.</p> <p>Added notes and specifications to Table 18 and Table 19.</p> <p>Updated the IOB Pad Input/Output/3-State discussion and changed Table 22 by adding $T_{IOIBUFDISABLE}$.</p> <p>Removed many of the combinatorial delay specifications and T_{CINCK}/T_{CKCIN} from Table 31.</p> <p>Rearranged Table 54 including moving some parameters to Table 1. Added Table 59. Updated Table 60. In Table 62, updated SJ Jitter Tolerance with Stressed Eye section, page 62 and Note 8. Added Note 1, Note 2, and Note 2 to Table 65. Added Note 1 and Note 2 to Table 66, and line rate ranges. Updated Table 67 including adding Note 1. Updated Table 68 including adding Note 1. In Table 70 updated Note 1 and added Note 4. In Table 71, updated T_{POR} and F_{EMCCK}.</p>
09/04/2012	1.7	<p>Updated Table 15 and Table 16 for production release of the XC7K160T in the -2, -2L(1.0V), and -1 speed designations.</p>
09/26/2012	1.8	<p>In Table 2, revised V_{CCINT} and V_{CCBRAM} and added Note 3. Updated Table 15 and Table 16 for production release of the XC7K480T in the -2, -2L(1.0V), and -1 speed designations and the XC7K325T and XC7K410T in the -3 speed designation.</p>
10/10/2012	1.9	<p>Updated the $I_{CCINTMIN}$ value for the XC7K355T in Table 7. Updated Table 15 and Table 16 for production release of the XC7K420T in the -2, -2L(1.0V), and -1 speed designations.</p>
10/25/2012	2.0	<p>Updated the AC Switching Characteristics based upon ISE 14.3 v1.07 for the -3, -2, -2L (1.0V), -1 speed specifications, and ISE 14.3 v1.06 for the -2L (0.9V) speed specifications throughout the document.</p> <p>Updated Table 15 and Table 16 for production release of the XC7K355T in the -2, -2L(1.0V), and -1 speed designations. Also updated Table 15 and Table 16 for production release of the XC7K325T and XC7K410T in the -2L (0.9V).</p> <p>Added values for Table 17 -2L (0.9V). Added package skew values to Table 53. In Table 56, increased -1 speed grade (FF package) F_{GTXMAX} value from 6.6 Gb/s to 8.0 Gb/s.</p>

Date	Version	Description
10/31/2012	2.1	Updated Table 15 and Table 16 for production release of the XC7K70T in the -2, -2L(1.0V), and -1 speed designations.
11/26/2012	2.2	Updated Table 15 and Table 16 for production release of -3 speed designation for XC7K70T, XC7K160T, XC7K355T, XC7K420T, and XC7K480T. Removed Note 4 from Table 70 .
12/05/2012	2.3	Updated Table 15 and Table 16 for production release of the -2L (0.9V) speed designation for XC7K160T, XC7K420T, and XC7K480T. Updated Note 1 in Table 53 .
12/12/2012	2.4	Updated Table 15 and Table 16 for production release of the -2L (0.9V) speed designation for XC7K70T and XC7K355T. Added Internal Configuration Access Port section to Table 71 .
10/04/2013	2.5	In Table 1 , revised V_{IN} (I/O input voltage) to match values in Table 4 and Table 5 , and combined Note 4 with old Note 5 and then added new Note 5 . Also in Table 1 , updated I_{DCIN} and I_{DCOUT} sections. Revised V_{IN} description and added Note 3 and Note 8 in Table 2 . Updated first 3 rows in Table 4 and Table 5 . Replaced XPower with Xilinx Power Estimator (XPE) in sentence before Table 7 . Updated V_{IL} minimum for PCI33_3 in Table 9 . Added Note 1 to Table 12 . Added Note 1 to Table 13 . Added Vivado Design Suite to AC Switching Characteristics . Updated titles of Table 18 and Table 19 , and removed the following note: <i>RLDRAM III (BL = 4, BL = 8) and LPDDR2 specifications have not been validated with memory IP</i> . Updated T_{IOOP} and T_{IOTP} values in Table 20 . Replaced "TRACE report" with "timing report" in notes for Table 28 , Table 29 , Table 30 , Table 32 , and Table 34 . Removed this note: <i>A Zero "0" Hold Time listing indicates no hold time or a negative hold time</i> from Table 32 , Table 33 , and Table 48 . Updated Note 1 in Table 38 . Updated Table 60 to more accurately show transceiver user clocks for supported line rates. Updated Note 8 and description of F_{GTXRX} in Table 62 . Updated Note 2 , Note 3 , and Note 4 in Table 70 . Added $T_{USRCLKO}$ to Table 71 .
11/27/2013	2.6	Added Kintex-7Q defense-grade devices throughout. Added -1M speed grade throughout. Added reference to 7 Series FPGAs Overview and Defense-Grade 7 Series FPGAs Overview in Introduction . In Table 2 , added junction temperature operating range for military (M) devices. In Table 3 , removed commercial (C), industrial (I), and extended (E) from descriptions of R_{IN_TERM} . Updated temperature ranges in Table 4 and Table 5 . Removed Note 1 and Note 2 from Table 7 . Added $T_J = 125^{\circ}\text{C}$ to Conditions column for $T_{VCCO2VCCAUX}$ in Table 8 . Added Table 14 . Updated description of $MMCM_F_{PFDMAX}$ in Table 41 . Updated description of PLL_F_{PFDMAX} in Table 42 . Added RF package type to Table 56 . Added F_{DNACK} to Table 71 .
02/07/2014	2.7	Updated the AC Switching Characteristics based upon ISE 14.7 and Vivado 2013.4. Updated Note 5 and added Note 6 to Table 2 . Added Note 2 to Table 4 . Added Note 2 and updated Note 3 in Table 5 . Added HSUL_12_F, DIFF_HSUL_12_F, MOBILE_DDR_S, MOBILE_DDR_F, DIFF_MOBILE_DDR_S, and DIFF_MOBILE_DDR_F standards to and updated values in Table 20 . Added HSUL_12_F, DIFF_HSUL_12_F, DIFF_HSUL_12_DCI_S, and DIFF_HSUL_12_DCI_F standards to and updated values in Table 21 . In Table 35 , corrected $F_{MAX_CAS_RF_DELAYED_WRITE}$ from 478.27 to 478.24 MHz to match software behavior. Removed introductory paragraph of Device Pin-to-Pin Output Parameter Guidelines and Device Pin-to-Pin Input Parameter Guidelines . Updated display format of "ADC Accuracy at Extended Temperatures" section in Table 70 .
03/04/2014	2.8	Updated Note 2 in Table 4 and Note 2 in Table 5 . For XQ7K325T and XQ7K410T in Table 15 , changed -2 and -1 speed grades to -2I and -1I, respectively, and moved all XQ7K325T speed grades from Preliminary to Production. In Table 16 , added production software for XQ7K325T -2/2L, -1, -1M, and (0.9V) -2L speed grades. Removed "and FB" from title of Table 19 . Removed notes from Table 20 and Table 21 . Added Note 1 to Table 69 .
06/20/2014	2.9	In Table 4 and Table 5 , updated Note 2 per the customer notice XCN14014: 7 Series FPGA and Zynq-7000 AP SoC I/O Undershoot Voltage Data Sheet Update . In Table 15 , moved all XQ7K410T speed grades from Preliminary to Production. In Table 16 , added production software for XQ7K410T -2/-2L, -1, -1M, and (0.9V) -2L speed grades and removed Note 2 . Added Note 3 to Table 18 . In Table 29 , added attribute REFCLK frequency of 400 MHz to $F_{IDELAYCTRL_REF}$ and average tap delay at 400 MHz to Note 1 . In Table 69 , updated Note 1 to Gen 2 and added reference to 7 Series FPGAs Integrated Block for PCI Express Product Guide (PG054) . In Table 71 , replaced USRCCLK Output with STARTUPE2 Ports and added F_{CFGCLK} and $F_{CFGCLKTOL}$.
09/08/2014	2.10	Updated Note 3 in Table 6 . In Power-On/Off Power Supply Sequencing , added sentence about there being no recommended sequence for supplies not shown. Added I/O Standard Adjustment Measurement Methodology . In Table 43 , updated description of T_{ICKOFF} and added Note 2 . In Table 44 , updated description of $T_{ICKOFFAR}$ and added Note 2 . In Table 54 , moved DV_{PPOUT} value of 1000 mV from Max to Min column, updated V_{IN} DC parameter description, and added Note 2 . Added "peak-to-peak" to labels in Figure 3 and Figure 4 .

Date	Version	Description
10/06/2014	2.11	Added -2LI (0.95V) speed grade throughout. Removed 3.3V as a descriptor of HR I/O banks and 1.8V as a descriptor of HP I/O banks throughout. Updated Introduction . Added -2LI (0.95V) to description of V_{CCINT} and V_{CCBRAM} in Table 2 . Added Note 1 and updated Note 2 in Table 16 . Updated Note 3 in Table 18 .
11/19/2014	2.12	Replaced -2L speed grade with -2LE throughout. Updated descriptions of V_{CCINT} and V_{CCBRAM} in Table 2 . Updated the AC Switching Characteristics based upon Vivado 2014.4. In Table 14 , updated Vivado software version to 1.12 and added a row for $V_{CCINT} = 0.95V$. In Table 15 , moved -2LI (0.95V) speed grade from Advance to Production. In Table 16 , added Vivado 2014.4 software version to -2LI (0.95V) speed grade column and removed notes. Added Selecting the Correct Speed Grade and Voltage in the Vivado Tools . Updated speed grade heading row in Table 56 . Added -2LI (0.95V) speed grade to Note 3 in Table 60 . Removed sentence about PCI Express x8 Gen 2 operation from Note 1 in Table 69 .
02/23/2015	2.13	In Table 12 , changed maximum V_{ICM} value from 1.425V to 1.500V. Removed minimum sample rate specification from Table 70 .
09/24/2015	2.14	Updated first two paragraphs in Introduction . Added -1LM speed grade to V_{CCINT} and V_{CCBRAM} descriptions in Table 2 . In Table 6 , added -1LM (1.0V) speed grade and assigned quiescent supply currents to -2LI speed grade Kintex-7Q devices. In Table 16 , changed -2LI speed grade Kintex-7Q device cells from N/A to blank, added -1LM speed grade, and added Note 1 . Added -1M and -1LM speed grades to Table 17 . Added introductory paragraph before Table 18 . Removed Pb-free G suffix from Table 18 and Table 19 titles and Note 3 . Updated Note 3 in Table 18 . Added -1LM speed grade in Table 18 to Table 52 , Table 57 , Table 60 , Table 69 , and Table 71 . Changed -2LI speed grade Kintex-7Q device cells from N/A to blank in Table 40 , Table 43 to Table 46 , and Table 48 to Table 50 . Added FBV484, FBV676, FFV676, FBV900, FFV900, FFV901, and FFV1156 packages to Table 53 . Added -1LM (1.0V) speed grade to Table 56 . Removed note about PCI-SIG 3.0 certification and compliance test boards from Table 65 .
11/24/2015	2.15	Updated the AC Switching Characteristics based upon Vivado 2015.4. In Table 15 , added -2LI (0.95V) and -1LM speed grades to Production column for XQ7K325T and XQ7K410T. In Table 16 , removed table note and added Vivado 2015.4 software version to -1LM and -2LI (0.95V) speed grades for XQ7K325T and -2LI (0.95V) speed grade for XQ7K410T. In Table 40 , added $T_{CKSKWEW}$ for XQ7K325T and XQ7K410T at -2LI (0.95V) speed grade. Updated device pin-to-pin output parameter tables (Table 43 to Table 46) and input parameter tables (Table 48 to Table 50) for XQ7K325T and XQ7K410T at -2LI (0.95V) speed grade.
05/08/2017	2.16	Updated Note 5 in Table 2 . Added Note 1 to Table 14 . Updated V_{MEAS} for LVCMOS33, LVTTTL, and PCI33_3 I/O standard attributes in Table 23 . In Table 29 , changed $T_{DELAYRESOLUTION}$ units from ps to μs . Updated Note 1 in Table 38 . Removed FBV484, FBV676, FFV676, FBV900, FFV900, FFV901, and FFV1156 packages from Table 53 per the customer notice XCN16022: Cross-ship of Lead-free Bump and Substrates in Lead-free (FFG/FBG/SBG) Packages . In Table 56 , improved GTX performance for FBG484 package in -2 and -3 speed grades (requires Vivado tools 2017.1), and added Note 1 , Note 5 , and Note 6 .
08/07/2018	2.16.1	Editorial updates only. No technical content updates.
05/15/2019	2.17	Added expanded temperature range and XA Kintex-7 FPGA Data Sheet: Overview (DS175) to Introduction . Added -1Q speed grade and XA7K160T throughout. In Table 2 , added -1Q to descriptions of V_{CCINT} and V_{CCBRAM} , and added junction temperature operating range for expanded (Q) temperature devices to T_j . Added XA Kintex-7 to second paragraph in Selecting the Correct Speed Grade and Voltage in the Vivado Tools . In Table 40 , updated T_{DCD_CLK} for -2LI speed grade to 0.20 ns.
06/28/2019	2.18	Updated Table 14 with Vivado 2019.1.1 speed specification versions. In Table 15 , moved -1Q speed grade for XA7K160T from Advance to Production. In Table 16 , added Vivado 2019.1.1 software version to -1Q speed grade column for XA7K160T.

Notice of Disclaimer

The information disclosed to you hereunder (the "Materials") is provided solely for the selection and use of Xilinx products. To the maximum extent permitted by applicable law: (1) Materials are made available "AS IS" and with all faults, Xilinx hereby DISCLAIMS ALL WARRANTIES AND CONDITIONS, EXPRESS, IMPLIED, OR STATUTORY, INCLUDING BUT NOT LIMITED TO WARRANTIES OF MERCHANTABILITY, NON-INFRINGEMENT, OR FITNESS FOR ANY PARTICULAR PURPOSE; and (2) Xilinx shall not be liable (whether in contract or tort, including negligence, or under any other theory of liability) for any loss or damage of any kind or nature related to, arising under, or in connection with, the Materials (including your use of the Materials), including for any direct, indirect, special, incidental, or consequential loss or damage (including loss of data, profits, goodwill, or any type of loss or damage suffered as a result of any action

brought by a third party) even if such damage or loss was reasonably foreseeable or Xilinx had been advised of the possibility of the same. Xilinx assumes no obligation to correct any errors contained in the Materials or to notify you of updates to the Materials or to product specifications. You may not reproduce, modify, distribute, or publicly display the Materials without prior written consent. Certain products are subject to the terms and conditions of Xilinx's limited warranty, please refer to Xilinx's Terms of Sale which can be viewed at www.xilinx.com/legal.htm#tos; IP cores may be subject to warranty and support terms contained in a license issued to you by Xilinx. Xilinx products are not designed or intended to be fail-safe or for use in any application requiring fail-safe performance; you assume sole risk and liability for use of Xilinx products in such critical applications, please refer to Xilinx's Terms of Sale which can be viewed at www.xilinx.com/legal.htm#tos.

AUTOMOTIVE APPLICATIONS DISCLAIMER

AUTOMOTIVE PRODUCTS (IDENTIFIED AS "XA" IN THE PART NUMBER) ARE NOT WARRANTED FOR USE IN THE DEPLOYMENT OF AIRBAGS OR FOR USE IN APPLICATIONS THAT AFFECT CONTROL OF A VEHICLE ("SAFETY APPLICATION") UNLESS THERE IS A SAFETY CONCEPT OR REDUNDANCY FEATURE CONSISTENT WITH THE ISO 26262 AUTOMOTIVE SAFETY STANDARD ("SAFETY DESIGN"). CUSTOMER SHALL, PRIOR TO USING OR DISTRIBUTING ANY SYSTEMS THAT INCORPORATE PRODUCTS, THOROUGHLY TEST SUCH SYSTEMS FOR SAFETY PURPOSES. USE OF PRODUCTS IN A SAFETY APPLICATION WITHOUT A SAFETY DESIGN IS FULLY AT THE RISK OF CUSTOMER, SUBJECT ONLY TO APPLICABLE LAWS AND REGULATIONS GOVERNING LIMITATIONS ON PRODUCT LIABILITY.