



ATR 421

Controller



User manual

Table of contents

1	Safety standards.....	5
2	Model identification.....	5
3	Technical data.....	5
	3.1 Main features.....	5
	3.2 Hardware features.....	6
	3.3 Software features.....	6
4	Size and installation.....	7
5	Electrical wirings.....	8
	5.1 Wiring diagram.....	8
6	Display and keys functions.....	12
	6.1 Numeric indicators (display).....	12
	6.2 Meaning of Status Lights (led).....	12
	6.3 Keys.....	13
7	Programming and configuration.....	13
	7.1 Programming (or modifying) cycle data.....	13
	7.1.1 Programming of starting setpoint (if enabled).....	14
	7.1.2 Programming of the step.....	14
	7.1.3 Programming of the auxiliary output (if configured).....	14
	7.1.4 Fine programmazione.....	15
8	Cycle start.....	15
	8.1 Start of a cycle and setting of delayed start.....	15
	8.2 Fast advancement during the cycle.....	16
	8.3 Simple controller function.....	16
	8.4 Output manual control.....	17
9	Programmer functions.....	17
	9.1 Hold function.....	17
	9.2 Automatic tuning.....	17
	9.3 Manual tuning.....	18
	9.4 Recovery of interrupted cycle.....	18
	9.4.1 Recovery with automatic gradient.....	18
	9.4.2 Recovery with recovery gradient.....	19
	9.5 Waiting step end.....	19
	9.6 Special functions for Gas kilns.....	20
	9.6.1 Gas - Outputs selection.....	20
	9.7 Gas - Management mode.....	20
	9.8 Feedback valve.....	21
	9.8.1 Heating / Cooling PID.....	21
	9.9 Loading default values / Reset.....	23
	9.10 Memory Card (optional).....	23
10	Serial communication.....	24
	10.1 Slave.....	24
	10.2 Master and remote setpoint.....	26
11	Configuration for installers.....	27
12	Table of configuration parameters.....	27
13	Alarm intervention modes.....	40
14	Table of Anomaly Signals.....	42

Sommario

1	Norme di sicurezza	45
2	Identificazione del modello.....	45
3	Dati tecnici.....	45
3.1	Caratteristiche generali.....	45
3.2	Caratteristiche hardware	46
3.3	Caratteristiche software.....	46
4	Dimensioni e installazione.....	47
5	Collegamenti elettrici.....	48
5.1	Schema di collegamento.....	48
6	Funzione dei visualizzatori e tasti.....	52
6.1	Indicatori numerici (display).....	52
6.2	Significato delle spie di stato (led).....	52
6.3	Tasti	53
7	Programmazione e configurazione.....	53
7.1	Programmazione (o modifica) dati di un ciclo.....	54
7.1.1	Programmazione del set point iniziale (se configurato)	54
7.1.2	Programmazione dello step (spezzata/passato)	54
7.1.3	Programmazione dell'uscita ausiliaria (se configurata)	55
7.1.4	Fine programmazione.....	55
8	Partenza di un ciclo di lavoro.....	55
8.1	Partenza del ciclo e impostazione partenza ritardata	55
8.2	Funzione avanzamento veloce.....	56
8.3	Funzione regolatore semplice.....	56
8.4	Controllo manuale dell'uscita.....	57
9	Funzioni del programmatore	57
9.1	Funzione Hold	57
9.2	Tuning automatico	58
9.3	Tuning manuale.....	58
9.4	Recupero ciclo interrotto.....	58
9.4.1	Recupero con gradiente automatico.....	59
9.4.2	Recupero con gradiente di recupero.....	59
9.5	Attesa fine step.....	60
9.6	Funzionamento gas.....	60
9.6.1	Gas - Selezione uscite.....	60
9.6.2	Gas - Modalità di gestione.....	60
9.7	Valvola retroazionata	61
9.7.1	Funzionamento in doppia azione (caldo-freddo)	61
9.8	Caricamento valori di default	63
9.9	Memory Card (opzionale)	63
10	Comunicazione seriale	64
10.1	Slave.....	64
10.2	Master e setpoint remoto	67
11	Configurazione per installatore.....	67
12	Tabella parametri di configurazione	68
13	Modi d'intervento allarmi.....	82
14	Tabella segnalazioni anomalie.....	84

Introduction

Thanks for choosing a Pixsys controller.

With ATR421 model Pixsys integrates in a single device all options for sensors reading and actuators control, beside an useful supply with extended range 24...230 Vac/Vdc. With the analogue universal input and the output configurable as relay or SSR, the user or the retailer can reduce stock needs. The series includes also a model with serial communication RS485 Modbus Rtu and linear output 0-10V, 0/4-20mA. The possibility to repeat parameterization is simplified by the Memory Cards with internal battery that do not require power supply for the controller.

1 Safety standards

Carefully read the instructions and safety measures in this manual before using the device. Disconnect power before performing any interventions on the electrical connections or hardware settings.

Only qualified personnel may use/perform maintenance in full respect of the technical data and declared environmental conditions.

Do not dispose of electrical appliances together with household waste.

In compliance with the European Directive 2002/96/EC, waste electrical equipment must be collected separately for eco-compatible reuse or recycling.

2 Model identification

ATR421 version includes two versions. Looking at the following table it is possible to find the required model.

Power supply 24...230 Vac/Vdc $\pm 15\%$ 50/60Hz – 5,5VA

ATR421-14ABC	1 Analogue input + 4 relays 8A + 1 SSR + D.I.
---------------------	---

ATR421-12ABC-T	1 Analogue input + 2 relays 8A + 1 SSR
	1 Output V/mA + RS485

3 Technical data

3.1 Main features

Displays	4 digits display 0,40 inches + 4 digits display 0,30 inches
Operating Temperature	Temperature 0-45°C - Humidity 35..95uR%
Sealing	Front panel IP54, box IP30, terminal blocks IP20
Material	Box: Noryl UL94V1 self-exstinguish Front panel: PC ABS UL94V0 self-exstinguish
Weight	Approx. 350 g

3.2 Hardware features

Analogue inputs	<p>AI1 - Configurable via software Thermocouples: type K,S,R,J,E,N. Automatic compensation of cold junction from 0...50 °C. Thermoresistances: PT100, Input V/mA: 0-10V, 0-20mA, 4-20mA. AI2 Feedback potentiometer input for motorized valves (max. 150 KΩ).</p>	<p>Tolerance (25°C) +/-0.2 % \pm 1 digit for thermocouple, thermoresistance and V/mA. Cold junction accuracy 0.1°C/°C Impedance: 0-10V: Ri>110KΩ 0-20mA: Ri<5Ω 4-20mA: Ri<5Ω</p>
Relay outputs	Configurable as control and alarm output.	Contacts: 8A-250V~ for resistive charges.
Output +24V	SSR and sensor supply	<ul style="list-style-type: none"> • 24Vdc-45mA to 115...230Vac • 24Vdc-25mA to 24Vac/dc
Output SSR	Configurable as control and alarm output.	24Vdc
Output V/I	Configurable as control output, alarm, retransmission of process or setpoint.	Configurable: 0-10V (9500 points) 0-20mA (7500 points) 4-20mA (6000 points)
Supply	Extended range 24...230Vac/Vdc \pm 15% 50/60Hz	Consumption: 5.5VA

3.3 Software features

Control algorithms	ON-OFF with hysteresis. P, PI, PID, PD time proportioned.
Proportional band	0...9999°C o °F
Integral time	0,0...999,9 sec (0 excludes)
Derivative time	0,0...999,9 sec (0 excludes)
Controller functions	Manual or automatic tuning, selectable alarms, special functions for gas/electric kilns.

4 Size and installation

Frontal panel cut-out
46 x 91 mm
Dimadi foratura

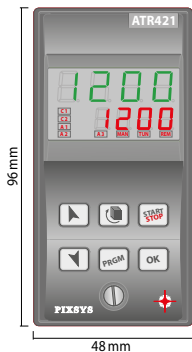

Memory Card
(optional - opzionale)
Cod. 2100.30.006

Memory Card with battery (optional)
Memory Card con batteria (opzionale)
2100.30.007

42 mm
Insert Memory Card
Inserimento Memory Card

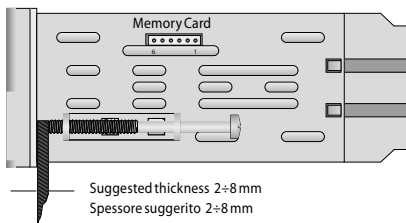
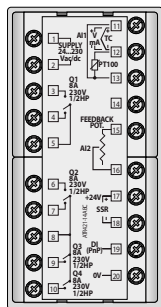
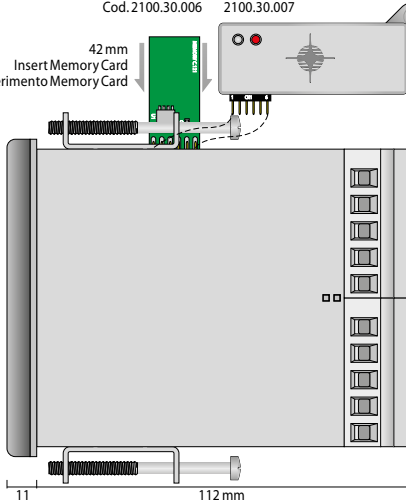

5 Electrical wirings

! Although this controller has been designed to resist noises in an industrial environments, please notice the following safety guidelines:

- Separate control lines from the power wires.
- Avoid the proximity of remote control switches, electromagnetic meters, powerful engines.
- Avoid the proximity of power groups, especially those with phase control.

5.1 Wiring diagram

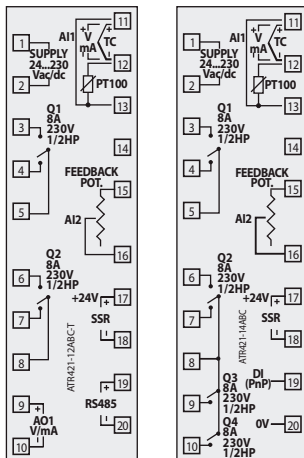

5.1.a Power supply



Switching supply with extended range
24...230 Vac/dc $\pm 15\%$ 50/60Hz – 5,5VA

5.1.b Analogue input AI1

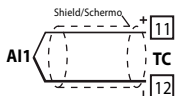

For thermocouples K, S, R, J, E, N.

- Comply with polarity
- For extensions make sure to use the correct extension/compensating cable
- When shielded cable is used, it should be grounded at one side only.

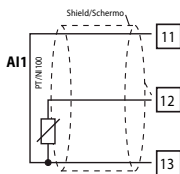

For thermoresistances PT100

- For a three-wires connection use cables with the same diameter.
- For a two-wires connection short-circuit terminals 11 and 13.
- When shielded cable is used, it should be grounded at one side only.

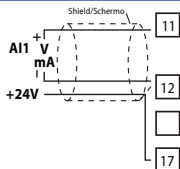
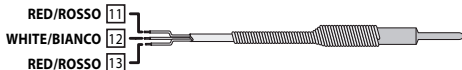

For linear signals Volt/mA

- Comply with polarity
- When shielded cable is used, it should be grounded at one side only.

5.1.c Analogue input AI2

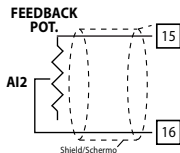

For feedback potentiometer on motorized valves

- Max. resistance 150 KΩ.
- When shielded cable is used, it should be grounded at one side only.

5.1.d Examples of connection for linear input AI1

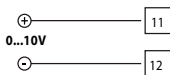

For linear signals 0...10V

- Comply with polarity

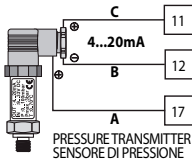

For linear signals 0/4...20mA with three-wires sensors

- Comply with polarity

C = Sensor output

B = Sensor ground

A = Sensor supply (24Vdc/25mA)

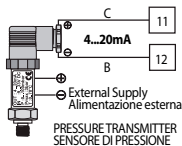

For linear signals 0/4..20mA with **external power supply for sensor**

- Comply with polarity

C = Sensor output
B = Sensor ground

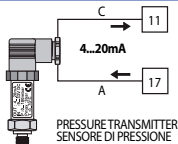

For linear signals 0/4..20mA with **two-wires sensors**

- Comply with polarity

C = Sensor output
A = Sensor supply (24Vdc/25mA)

5.1.e Digital input (ATR421-14ABC)

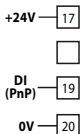

Digital input (parameter $dU_{L. i.}$).

- Close terminal "DI" (19) on terminal "+24V" (17) to activate digital input.

5.1.f SSR output



Command output SSR: 24Vdc

NB: output +24V (17) can deliver totally 45mA if the ATR421 is supplied at 115...230Vac and 25mA if it is supplied at 24Vac/dc

5.1.g Relay outputs Q1, Q2

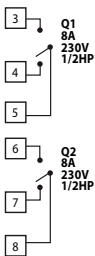

Contacts capacity:

- 8A, 250Vac, resistive charge 10^5 operations.
- 30/3A, 250Vac, $\cos\phi=0.3$, 10^5 operations.

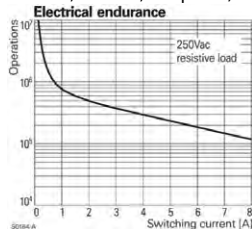

5.1.h Relay outputs Q3, Q4 (ATR421-14ABC)

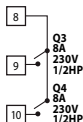

Contacts capacity:

- 8A, 250Vac, resistive charge 10^5 operations.
- 30/3A, 250Vac, $\cos\varphi=0.3$, 10^5 operations.

5.1.i Output mA / Volt (ATR421-12ABC-T)

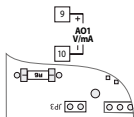

Analogue output in mA configurable as command (Par. $c.o.u.t$) or retransmission of process-setpoint (Par. $r.E.t.r.$).
To use analogue output in mA DO NOT enter JP3.

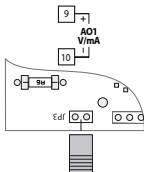

Analogue output in Volt configurable as command (Par. $c.o.u.t$) or retransmission of process-setpoint (Par. $r.E.t.r.$).

To use analogue output in Volt enter JP3 as indicated in the figure.

5.1.j Serial input (ATR421-12ABC-T)

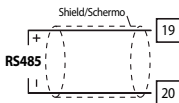

Communication RS485 ModbusRTU with galvanic isolation.

6 Display and keys functions

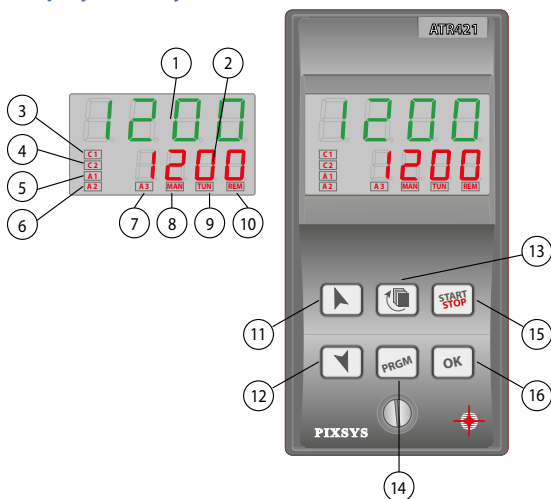



6.1 Numeric indicators (display)

- | | | |
|---|--|--|
| 1 | | Usually visualizes process value, it may visualize also setpoint value, time elapsed from cycle start, number of operating step or the percentage value of the command output. During configuration it visualizes the value of entering parameter. |
| 2 | | Visualization can be customized with setpoint, time elapsed from cycle start or number of operating step. During configuration it visualizes the value of entering parameter. |

6.2 Meaning of Status Lights (led)

- | | | |
|----|--|---|
| 3 | | On when command output is active. For open /close logic: on during valve opening. |
| 4 | | For open/ close logic: on during valve closing. |
| 5 | | On when alarm 1 is active. |
| 6 | | On when alarm 2 is active. |
| 7 | | On when alarm 3 is active. |
| 8 | | On when "Manual" function is active |
| 9 | | On when controller is executing an auto-tuning cycle. |
| 10 | | On when serial communication is in progress. |

6.3 Keys

- In configuration allows to scroll and modify parameters.
 - Scroll cycles to be started or modified.
- 11 
- In cycle programming allows to modify time and setpoint parameters.
 - Modifies setpoint in $\xi H E r$. function.
 - Modifies command output percentage in $\Pi A n$. function.
 - Allows a quick advancement of the cycle when it is in "START".
-
- 12 
- In configuration allows to scroll and modify parameters.
 - Scroll cycles to be started or modified.
 - In cycle programming allows to modify time and setpoint parameters.
 - Modifies setpoint in $\xi H E r$. function.
 - Modifies command output percentage in $\Pi A n$. function.
 - Allows a quick retrograde of the cycle when it is in "START".
-
- 13 
- With controller in **STOP** it visualize the duration of the last cycle.
 - In configuration it assigns a mnemonic code or a number to the selected parameter.
 - During a cycle it allows to visualize cycling the setpoint and the other data.
-
- 14 "PRGM"
- With controller in **STOP** allows to enter cycle modification and configuration.
 - During a cycle, if pressed for 1 second, it allows to activate/deactivate HOLD function.
-
- 15 "START"
"STOP"
- Start/Stop a cycle.
 - In parameter configuration and cycle data modification, it is used as exit key (ESCAPE).
-
- 16 "OK"
- Value or selected function confirmation.

7 Programming and configuration

There are two programming levels:

1. **Cycles programming** (for operator/user) means entering time/setpoint values for each step of cycle.
2. **Configuration** (for manufacturer/installer of plant), to enter main parameters (sensor type, output type, auxiliary output intervention type ext.).

7.1 Programming (or modifying) cycle data

With or without starting setpoint and timed auxiliary outputs.

The above specifications underline the possibility given to the installer (plant's manufacturer) to choose the sequence of operations required for the programming of a firing cycle.

This paragraph includes all available options. In case that the installer decides to choose a simplified programming with less options, it is highly recommended to prepare additional instructions specifying only the chosen sequence.

Set the controller in $\mathcal{S}_{\mathcal{L}OP}$ and follow the points below:

	Press	Display	Do
1	"PRGM"	Red display shows $\mathcal{C}Y.01$	
2	"^" "v"		Decrease or increase to visualize $\mathcal{C}Y.01$ (for cycle no.1), $\mathcal{C}Y.02$ (for cycle no.2) up to $\mathcal{C}Y.15$ (for cycle no.15).

7.1.1 Programming of starting setpoint (if enabled)

This is useful for example when the kiln is still hot and cycle has to start from a lower temperature.

	Press	Display	Do
3	"OK"	Red display shows $00-5.*$ Green display shows "starting setpoint". Otherwise pass to point 5.	At any time press "START STOP" to exit programming with storing modified data.
4	"^" "v"	Increase or decrease value on green display.	Enter starting setpoint (starting temperature)

7.1.2 Programming of the step

	Press	Display	Do
5	"OK"	Red display shows $01-1.$ Green display shows step time.	
6	"^" "v"	NB: Each cycle is composed of max. 45 programmable steps, after those it skips automatically to point 12.	NB: Set for endless time or --.-- for cycle end (if not all steps are used) and skip to point 11.
7	"OK"	Red display shows $01-5.$ Green display shows the step setpoint (temperature that has to be reached within given time).	With keys "^" or "v" enter setpoint (temperature reached at step end).

7.1.3 Programming of the auxiliary output (if configured)

	Press	Display	Do
8	"OK"	Red display shows $01-A.$ Green display shows $A1.0F$ or $A1.0N.$	If $A1.1$ is not programmed as auxiliary time ($A.0.r.5$) skip to point 10.

	Press	Display	Do
9			Set auxiliary output status during the step: <i>AL.ON</i> for active output and <i>AL.OF</i> for not active output.
10	"OK"		If <i>AL.2</i> , <i>AL.3</i> or <i>AL.4</i> are programmed as time auxiliary go back to point 9. Green display will visualize the number and the status of the selected auxiliary (<i>AL.OF/ AL.ON</i> , <i>AL.3.OF/ AL.3.ON</i> or <i>AL.4.OF/ AL.4.ON</i>). Once selected all auxiliary go back to point 5.

7.1.4 Fine programmazione

	Press	Display	Do
11	"OK"	Controller returns in STOP mode saving the cycle. Red display shows <i>StOP</i> .	If <i>AL.1</i> , <i>AL.2</i> , <i>AL.3</i> or <i>AL.4</i> are selected as auxiliary (<i>A.O.r.5</i>) repeat the procedure of points 9 and 10 for the output status at cycle end.

8 Cycle start



8.1 Start of a cycle and setting of delayed start

Red display shows *StOP*.

	Press	Display	Do
1	"START" "STOP"	Red display shows cycle selection.	
2			Decrease or Increase until chosen cycle is visualized <i>cY.01</i> (for cycle no.1), <i>cY.02</i> (for cycle no.2),
3	"OK" or "START" "STOP"	Cycle starts. Buzzer sounds for a second. Green display shows the process while red display shows the setpoint introduced on parameter <i>29 u.i.d.2</i> .	



If function "Delayed start" is enabled (see parameter *30 dESt*) follow the points below:

	Press	Display	Do
4	"OK" or "START" "STOP"	Red display shows <i>UAt</i> while green display shows the programmed waiting time flashing.	
5			Increase or decrease time for delayed start (hours:minutes).

	Press	Display	Do
6	"OK"	Start of waiting time. At elapsing of programmed time, cycle will start.	Press "  or "  to modify the time.





8.2 Fast advancement during the cycle

During functioning or after a restart it can be useful to onwards or backwards the cycle in progress, to reach chosen setpoint value.

	Press	Display	Do
1	 or 	Forwards or backwards (each beep of internal buzzer means one minute).	To stop the cycle and set the controller in , before cycle end press "START STOP" for a second.

8.3 Simple controller function¹

STOP controller.

	Press	Display	Do
1	"START" "STOP"	Red display shows selected cycle.	
2			Increase until visualize tHER.
3	"OK" or "START" "STOP"	Red display shows SP _U while green display shows the setpoint.	
4	 or 	Increase or decrease setpoint value.	Enter chosen setpoint value.
5	"OK"	Controller modulates the command output to keep the programmed temperature.	
6		Visualize controller values cycling.	To modify setpoint SP _U press "  and/or arrow keys. To exit, press "START STOP" for a second.

¹ Access to this function have to be enabled on parameter 32 SP_{F_U}, this function cannot be used on gas kilns.

8.4 Output manual control²

This function allows to modify manually the command output, excluding the process control. Output will activate in percentage from 0 to 100% according to time base set on parameter 23 $t.c.$ (cycle time) or on parameter 43 $uRL.t.$ if parameter 1 $c.out$ is set on $c.uRL$.

SP controller and follow the table below.

	Press	Display	Do
1	"START" "STOP"	Red display shows cycle selection.	
2	"^"		Increase until visualize $\eta\eta\eta$.
3	"OK"	Green display shows the process. Red display shows $P---$, where the output percentage value is visualized. Controller starts to modulate the command output.	To modify percentage pres "^" or "v". To esc press "START STOP" for a second.

9 Programmer functions

9.1 Hold function

This function allows to interrupt the cycle: red display visualizes and cycle advancement is stopped. By pressing "^" and "v" it is also possible to modify the setpoint.

There are two possibilities to start this function:

- By keyboard: set E_n on parameter 33 $HLD.F$. Press "PRGM" for a second: function will be started or stopped.
- By digital input: select $Hold$ on parameter 27 $dGt.i.$ (only for ATR421-14ABC).

NB: It is not possible to enable Hold function by parameter 33 $HLD.F$ if parameter 27 $dGt.i.$ has already been set on $Hold$.

9.2 Automatic tuning

Automatic tuning procedure has been conceived to give user the possibility to have a clear regulation also without knowledge of PID regulation algorithm. Setting $Autot$ on parameter 11 $t.unE$, the controller will check process oscillations and will modify PID parameters if the difference between process and setpoint values is greater than value on P-13 $\eta.G.t.u.$



Parameters 13 $\eta.G.t.u.$, 14 $\eta.n.P.b.$, 15 $\eta\eta.P.b.$ and 16 $\eta.n.i.t.$ can be modified entering the dedicated password 5678.

² Access to this function have to be enabled on parameter 32 $SPF.u.$, this function cannot be used on gas kilns.

9.3 Manual tuning



Manual tuning procedure allows user a greater flexibility on deciding to update PID parameters. To enable this function set PI_n on parameter 11 t_{unE} .

To start manual tuning procedure, follow the table below:

	Press	Display
1		Press until red display shows t_{unE} .
2		Green display shows on, led TUN turns on and procedure starts.

Controller activates output increasing (or decreasing - if cooling regulation) the process value entered on parameter 12 $S_d.t_u$. Then it turns off the output and calculates the new PID parameters depending from overshoot/undershoot oscillations.

It is possible to end manual tuning procedure any time, following the points below:

	Press	Display
1		Press until red display shows t_{unE} .
2		Green display shows off, led TUN turns off and procedure ends. PID parameters will not be modified.

9.4 Recovery of interrupted cycle

Recovery function is particularly useful for kilns temperature regulation. After a power failure, at restarting, ATR421 can resume the interrupted cycle. There are two recovery modes:

9.4.1 Recovery with automatic gradient

To enable cycle recovery with automatic gradient, set 1 parameter 38 as $r_{i.c.g}$. This mode does not operate for cooling regulations. At restart, after a power failure, controller will operate like this:

1. If a power failure occurs during a rising step, the gradient will be those of the operating step with the setpoint temperature equal to the temperature read by the sensor.
2. If a power failure occurs during a holding step, two options are possible. If gap between process and setpoint is limited (not exceeding the value on parameter 37 $\Delta t_{s.E}$) cycle will resume from the point of interruption; if the gap is bigger but controller has not yet executed a cooling step, the cycle will go back to the closest rising step and will repeat the procedure as explained on point 1.
3. If a power failure occurs during a cooling step or a holding step (dwell) after that a cooling step has already been completed, the setpoint will match the the temperature read by the sensor, without including any rising and even skipping to next step if necessary (this a safety tip particularly for glass working).

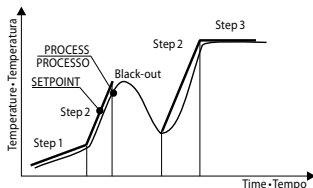

NB: After a power-off the chronometer will restart from 00:00.

9.4.2 Recovery with recovery gradient

To enable cycle recovery with a recovery gradient, enter on parameter 38 *r. r.c.g.* a value (degrees/hour if temperature) greater than 1. At restarting if the kiln temperature (process) is lower than the setpoint, ATR421 locks the working cycle executing a step with the rising gradient set on parameter 38 *r. r.c.g.* to return to the setpoint value entered before the power failure and the cycle restarts from that point.

In recovery mode the point on the right of the red display flashes and display shows *rEc.* instead of the cycle number.

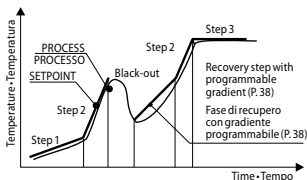

- Recovery will start only for holding steps or rising steps in heating regulation or for falling steps in cooling regulation.
- To exit manually from recovery mode press "**^**" or "**v**".

9.5 Waiting step end

This function has been conceived to control kilns working cycles, whenever the kiln cannot follow gradients programmed by the user. If at step end the difference between process and setpoint values is greater than the value on parameter 37, controller starts with the next step only after waiting for the time programmed on parameter 36 *U.L.S.E.*, or when this gap becomes lower than parameter 37 *P.G.S.E.*

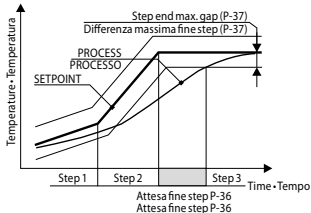

- To exit manually from step end waiting function press “^”.
- To disable this function fix at 0 end step waiting time U.E.S.E.
- During end step waiting red display shows UR iE.

9.6 Special functions for Gas kilns

ATR421 integrates gas kilns control functions. For a correct operation it is necessary to check the following settings.

9.6.1 Gas - Outputs selection

- **Valve selection.** Select `VAL` on parameter 1 `OUT`. Q1 becomes command valve. N.O. and N.C. contacts of this output are activated independently from each other: this allows to connect valve “open” command between pins 3 and 5, while “close” command has to be connected to pins 4 and 5.
- **Burners selection.** Select `BURN` on one of the parameters for alarm selection. Ex.: setting `BURN` on parameter 45 `AL1` burner function is assigned to alarm 1.
- **Fans selection.** Select `FANS` on one of the parameters for alarm selection. Ex.: setting `FANS` on parameter 52 `AL2` fans function is assigned to alarm 2.

Referring to table of parameter 1 (description of the available options for `OUT`) it is possible to check alarm-output match.

9.7 Gas – Management mode

Gas kilns management assigns the outputs commands according to the type of the step: during rising and holding steps the fans are switched on and when the setpoint value is greater than the process value burners are also switched on. After elapsing of the time set on parameter 39 `B.U.S.E.` since burners switch-on, controller considers the flame lighted and so (if necessary) it updates the setpoints (as the process value could have decreased in the meantime).

If the temperature value is greater than the setpoint introduced on parameter 40 `E.S.O.B.` burners switch off, they will restart when temperature goes down again; parameter 41 `B.HY` defines burners command hysteresis.

For falling steps, if the temperature value is lower than the setpoint on parameter 42 `E.S.O.F.` fans will switch off.

Output management is also different according to the selection on parameter 18 `RC.E.T.` Below all available options:

- `GRS`: during falling steps burners stay off.
- `G.F.S.` (Gas Falling Steps) (GID). During falling steps burners work in ON/OFF mode:

the servo valve regulates air flow for cooling and it is always closed when burners are switched on.

- **G.F.S.S.** (Gas Falling Steps Servovalve) (GIDS). During falling steps gas modulation is done by servo valve: management is the same as for rising and holding steps.

If a feedback valve is used, parameters 24 *L.L.O.P.* and 25 *U.L.O.P.* determinate max. and min. limit for valve opening when burners are switched on: with burners switched off, valve will open and close totally.

9.8 Feedback valve

ATR421 allows to connect to AI2 the feedback potentiometer of a motorized valve. Remember to calibrate the potentiometer to allow the controller establish precisely valve limits. After valve ("open" pins 3-5 and "close" pin 4-5) and the potentiometer (pins 15-16) have been connected, select *C.U.R.L.* on parameter 1 *C.O.U.T.* and *P.O.C.R.* on parameter 44 *F.E.P.O.*: exiting configuration mode, controller will automatically start to open and close the valve in order to fix limits.

Once this procedure ends, controller selects *E.N.* on parameter 44 *F.E.P.O.*. If a new potentiometer procedure is required, it will be necessary to set *P.O.C.R.* on parameter 44 *F.E.P.O.*.

NB. setting *d.i.s.* on parameter 44 *F.E.P.O.* the valve DOESN'T works with feedback: it is necessary to set the valve time on parameter 43 *U.R.L.T.*

9.8.1 Heating / Cooling PID

ATR421 is suitable also for applications requiring a combined heating-cooling P.I.D. action.

Command output has to be configured as heating PID (*R.C.T.E.* = *H.E.R.T.* and *P.b.* greater than 0), and one of alarms (*A.L.1*, *A.L.2*, *A.L.3* or *A.L.4*) has to be configured as *C.O.O.L.*. Command output must be connected to actuator responsible for heating action, while alarm will control the cooling action.

Parameters to configure for heating PID are:

R.C.T.E. = *H.E.R.T.* Command output action type (Heating)

P.b.: Proportional band heating

I.t.: Integral time Heating and cooling

D.t.: Derivative time Heating and cooling

C.c.: Cycle time Heating

Parameters to configure for cooling PID are (example: action associated to alarm 1):

A.L.1 = *C.O.O.L.* Alarm1 selection (Cooling)

P.b.Π.: Proportional band multiplier

O.V.D.B.: Overlapping / Dead band

C.O.C.T.: Cycle time Cooling

Parameter *P.b.Π.* (that ranges from 1.00 to 5.00) determinates the proportional band for cooling action, according to the formula:

- **Proportional band for cooling action:** = $P.b. * P.b.Π.$

In this way it is possible to have a proportional band for cooling action that will be equal to heating proportional band if $P.b.\eta. = 1.00$, or 5 times greater if $P.b.\eta. = 5.00$.

- **Integral and Derivative time** are the same for both actions.

Parameter $o.u.d.b.$ establishes the overlapping (in percentage) between the two actions. For installations where heating and cooling outputs cannot be activated at the same time, a Dead band will be configured ($o.u.d.b. \leq 0$), viceversa an overlapping will be configured ($o.u.d.b. > 0$).

Figure below shows an example of double action PID (heating-cooling) with $t.i. = 0$ and $t.d. = 0$.

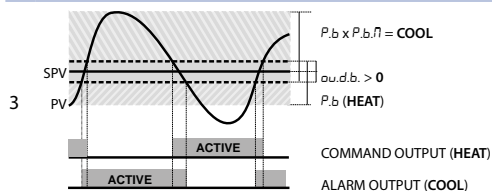
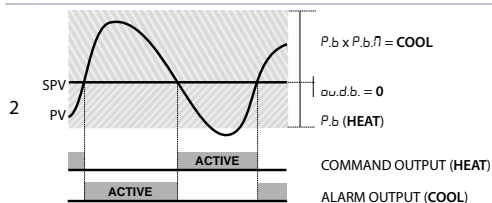
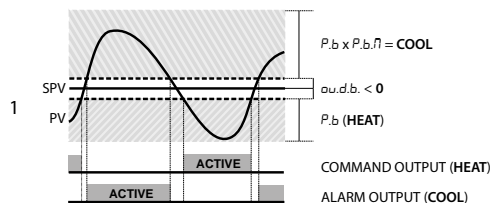

Parameter $c.o.c.t.$ has the same meaning of cycle time for heating action $t.c.$

Parameter $c.o.o.f.$ (Cooling Fluid) pre-selects the proportional band multiplier and the cooling P.I.D. cycle time $P.b.\eta.$, according to cooling fluid type.

$c.o.o.f.$	Cooling fluid type	$P.b.\eta.$	$c.o.c.t.$
Air	Air	1.00	10
Oil	Oil	1.25	4
Water	Water	2.50	2

Once parameter $COD.F.$ has been selected, parameters $P.b.\bar{n}.$ / $ou.d.b.$ and $co.c.t.$ can be however modified.

9.9 Loading default values / Reset

This procedure allows to restore all default settings.

	Press	Display	Do
1	"PRGM"	Red display shows cycle selection.	
2	"^"		Increase until $COD.F.$ is visualized.
3	"OK"	Green display shows 0000 with 1st digit flashing, while red display shows $PASS.$	
4	"^" " <v>" + "</v>	Flashing digit on green display changes.	Enter password 9999.
5	"OK"	Device loads default settings.	

Entering password 9999 all default parameters will be loaded. If it is necessary to cancel and reset also the cycles, enter password 9989.

9.10 Memory Card (optional)

Parameters and setpoint values can be easily copied from one controller to others using the Memory Card. Two modes are available:

- **With the controller connected to the power supply:**

Insert Memory card **when the controller is off**.

At switch-on green display shows $MEMD$ and red display shows ---- (only if correct values are stored on Memory).

Pressing " red display visualizes $LOAD$. Confirm with "OK". Controller loads new values and restarts.

- **With the controller not connected to the power supply:**

The memory card is equipped with an internal battery with an autonomy of about 1000 uses. Insert the memory card and press the programming button. When writing the parameters, led turns red and on completing the procedure it turns to green. It is possible to repeat the procedure without any particular attention.

Updating Memory Card

To update the memory card values, follow the procedure described in the first method, setting ---- on red display so as not to load the parameters on controller³. Enter configuration and change at least one parameter. Exit configuration. Changes are saved automatically.

³ If at starting controller shows $MEMD$ it means that no data are stored into the Memory Card, however values can be update.

10 Serial communication

ATR421-12ABC-T is provided with isolated RS485 serial and can receive/transmit data via MODBUS RTU protocol. Device can be configured as master or slave.

Modbus RTU protocol features

Baud-rate	Selectable by parameter 78 <i>bd.rL</i> .	
	4.8 ↗ 4800 bit/sec	9.6 ↗ 9600bit/sec
	19.2 ↗ 19200bit/sec	28.8 ↗ 28800bit/sec
	57.6 ↗ 57600bit/sec	115.2 ↗ 115200bit/sec
Format	Selectable by parameter 79 <i>SE.P.5</i> .	
	<i>B.n.l</i>	8 data bits, no parity, 1 stop bit.
	<i>B.o.l</i>	8 data bits, odd parity, 1 stop bit.
	<i>B.E.l</i>	8 data bits, even parity, 1 stop bit.
Supported functions	WORD READING (max 20 word) (0x03, 0x04)	
	SINGLE WORD WRITING (0x06)	
	MULTIPLE WORDS WRITING (max 20 word) (0x10)	

10.1 Slave

ATR421-12ABC-T can operate as slave unit setting *d.5*. on parameter 77 *rEΠ.5*: this function allows to control multiple controllers connected to a supervisory system. Each instrument will answer to a Master query only if contains same address as on parameter 80 *SLAd*. Allowed addresses are 1 to 254 and there should not be controllers with the same address on the same line. Address 255 can be used by the Master to communicate with all connected devices without knowing their addresses (broadcast mode), while with address 0 all devices receive command, but no answer is expected. ATR421 can introduce an answer delay (in milliseconds) to Master request. This delay has to be set on parameter 81 *SE.dE*. At each parameters modification, instrument stores values in EEPROM memory (100000 writing cycles). **NB:** Modifications made to Words different from those described in the following table can lead to instrument malfunction.

Here below list of available addresses

	RO = Read Only	R/W = Read / Write	WO = Write Only
Modbus address	Description		Read Write Reset value
0	Device type		RO 210
1	Software version		RO FLASH
5	Slave address		R/W EEPROM
6	Boot version		RO FLASH
50	Automatic addressing		WO -
51	Installation code comparison		WO -
	Loading Default values:		
500	9999 restore all values except for cycles		RW 0
	9989 restore all values, cycles included		

Modbus address	Description	Read Write	Reset value
900	AI1 process (degrees with tenths of degree for temperature sensors; digits for linear sensors).	RO	-
901	AI2 process (feedback potentiometer-Ohm/10)	RO	-
902	Valve position – 0...100.	RO	-
1000	Process (degrees with tenths of degree for temperature sensors; digits for linear sensors).	RO	-
1001	Process with decimal point selection.	RO	-
1002	Setpoint (with gradient)	RO	0
1003	Setpoint with process decimal point selection	RO	0
1004	Digital input status 0 = input OFF 1 = input ON	RO	0
	Relay status (0=off, 1=on)		
1005	Bit 0 = relay Q4 Bit 3 = relay Q2 Bit 1 = relay Q3 Bit 4 = relay Q1 n.c. Bit 2 = relay Q1 n.o. Bit 5 = SSR	RO	0
1006	Heating output percentage (0-10000)	RO	0
1007	Cooling output percentage (0-10000)	RO	0
1008	Heating output percentage (0-1000)	RO	0
1009	Cooling output percentage (0-1000)	RO	0
1010	Heating output percentage (0-100)		0
1011	Cooling output percentage (0-100)	RO	0
	Alarms status (0=none, 1=active)		
1012	Bit0 = Alarm 1 Bit2 = Alarm 3 Bit1 = Alarm 2 Bit3 = Alarm 4	RO	0
	Error flags		
	Bit0 = Eeprom writing error		
	Bit1 = Eeprom reading error		
	Bit2 = Cold junction error		
	Bit3 = Error AI1 (sensor 1)		
1013	Bit4 = Error AI2 (sensor 2 - potentiometer)	RO	0
	Bit5 = Generic error		
	Bit6 = Hardware error		
	Bit7 = Missing calibration error		
	Bit8 = Eeprom cycle reading error		
	Bit9 = Not calibrate feedback potentiometer error		
1014	Cold junction temperature (degrees with tenth)	RO	-
	Cycle selection for remote start		
	1 = cycle1		
1200	... 15 = cycle15 16 = controller 17 = output manual control	R/W	1

Modbus address	Description	Read Write	Reset value
1201	Remote Start/Stop (0 = STOP, 1 = START)	R/W	0
1202	Remote setpoint for controller (degrees with tenths of degree for temperature sensors; digits for linear sensors).	R/W	0
1203	Remote setpoint for controller with process decimal point selection.	R/W	0
1204	Remote manual control output percentage (0-100)	R/W	0
1205	Remote manual control output percentage (0-1000)	R/W	0
1206	Remote manual control output percentage (0-10000)	R/W	0
1207	Manual tuning ON/OFF 0 = Tuning off 1 = Tuning on	R/W	0
1210	OFF LINE time* (milliseconds)	R/W	0
2001	Parameter 1	R/W	EEPROM
....	R/W	EEPROM
2100	Parameter 100	R/W	EEPROM
4001	Parameter 1**	R/W	EEPROM
....	R/W	EEPROM
4100	Parameter 100	R/W	EEPROM

10.2 Master and remote setpoint

ATR421-12ABC-T includes a simplified Master mode allowing operation with other programmers ATR421-12ABC-T or with controllers ATR401-22ABC-T.

Setting \overline{MSL} on parameter $77rEN.5$. controller transmits in broadcast (address 0) its status (start/stop) and the control setpoint.

Following table shows all data:

Modbus Address	Description
5000	Controllers status: 0 = Controller in stop 1 = Controller during initial waiting 2 = Controller in start
5001	Setpoint remote

Setting \overline{SLU} on parameter $77rEN.5$. controller is normally in stop mode; it goes in start when the master device on the serial line starts a cycle.

11 Configuration for installers

To accede configuration parameters it is necessary to *StoP* the controller.

	Press	Display	Do
1	"PRGM"	Red display shows cycle selection.	
2	"^"		Increase until visualize <i>CONF</i> .
3	"OK"	On green display appears 0000 with 1st digit flashing, while red display shows <i>PASS</i> .	
4	"^" "v" + "OK"	Flashing digit of green display changes.	Enter password 1234.
5	"OK"	Green display shows the first parameter while red display shows the value.	
6	"<"	Allows to switch from mnemonic to numeric parameter visualization (and vice versa).	
7	"^" "v"	Scroll parameters.	Vialize parameter to be modify.
8	"OK"	Allows parameter modification: on red display the chosen parameter value starts flashing.	
9	"^" "v"	Increase or decrease visualized value.	Enter new data.
10	"OK"	Confirms data entering (red display stops flashing).	To modify a new parameter back to point 7.
11	"START" "STOP"	Configuration ends. Controller is in <i>StoP</i> . NB: If a memory card is introduced, in a few minutes it will be updated according to the modifications done.	

12 Table of configuration parameters

1 *c.oUt* Command Output

Command output type selection.

c. o l > **Default** (Default parameter).

c.uPL.

c.SSc

c.4.20

c.0.20

c.0.10

ATR421 - 14ABC

	Command	Alarm 1	Alarm 2	Alarm 3	Alarm 4
<i>c. oI</i>	Q1	Q2	Q3	Q4	SSR
<i>c.uRL</i>	Q1 3-5 (open) 4-5 (close)	Q2	Q3	Q4	SSR
<i>c.SSr</i>	SRR	Q2	Q3	Q4	Q1

ATR421 - 12ABC-T

	Command	Alarm 1	Alarm 2	Alarm 3
<i>c. oI</i>	Q1	Q2	SSR	AO1 (V)
<i>c.uRL</i>	Q1 3-5 (open) 4-5 (close)	Q2	SSR	AO1 (V)
<i>c.SSr</i>	SRR	Q2	Q1	AO1 (V)
<i>c.4.20</i>	4...20mA	Q2	Q1	SSR
<i>c.0.20</i>	0...20mA	Q2	Q1	SSR
<i>c.0.10</i>	0...10V	Q2	Q1	SSR

2 *SEn*. Sensor

Analogue input 1 configuration.

t.c. T Tc-K: -260...1360°C >Default

t.c. S Tc-S: -40...1760°C

t.c. r Tc-R: -40...1760°C

t.c. J Tc-J: -200...980°C

t.c. E Tc-E: -260...740°C

t.c. n Tc-N: -260...1280°C

Pt PT100: -200...600°C

0-10 0...10Volt

0-20 0...20mA

4-20 4...20mA

SPu Setpoint (setpoint value is visualized as process)

3 *d.P.* Decimal Point

Selects type of visualized decimal point.

0 > Default

0.0

0.00

0.000

4 *LoLr*. Lower Linear Input

All lower limit range, only for linear.

-999...+9999 [digit⁴]. **Default:** 0.

5 *uPLr*. Upperr Linear Input

All upper limit range, only for linear.

-999...+9999 [digit⁴]. **Default:** 1000.

6 *o.cAL*. Offset Calibration

Number added to visualized process (normally it corrects ambient temperature value).

-999...+1000 [digit³]. **Default:** 0.0.

7 *G.cAL*. Gain Calibration

Number multiplied with process value to calibrate working point.

-99.9%...+100.0%. **Default:** 0.0.

8 *LoL.S*. Lower Limit Setpoint

Setpoint lower limit.

-999...+9999 [digit³] (degrees.tenths for temperature sensors). **Default:** 0.

9 *uPL.S*. Upper Limit Setpoint

Setpoint upper limit.

-999...+9999 [digit³] (degrees.tenths for temperature sensors). **Default:** 1750.

10 *dEGr*. Degree

Select degree type

C Centigrade. > **Default.**

F Fahrenheit.

11 *tunE* Tune

Select autotuning type.

d.i.S. Disabled. > **Default.**

Auto Automatic. Controller checks constantly the process value and modifies P.I.D. values (if necessary).

MAN. Manual. Started by keys or digital input.

12 *S.d.tu*. Setpoint Deviation Tune

Selects deviation from command setpoint as threshold used by manual tuning to calculate P.I.D. parameters.

0...5000 [digit³] (degrees.tenths for temperature sensors). > **Default:** 5.0.

⁴ The display of the decimal point depends on the setting of parameters *SEn*, and *d.P.*

13 П.Г.Е.В. Max Gap Tune

Selects the max. process-setpoint gap, beyond which the automatic tune recalculates P.I.D. parameters.

1...500 [digit⁵] (degrees.tenths for temperature sensors). > **Default:** 1.0.

14 П.н.Р.б. Minimum Proportional Band:

Selects proportional band min. value selectable by automatic tune.

0...9999 [digit⁵] (degrees.tenths for temperature sensors). > **Default:** 5.0.

15 П.н.Р.б. Maximum Proportional Band

Selects proportional band max. value selectable by automatic tune.

0...9999 [digit⁵] (degrees.tenths for temperature sensors). > **Default:** 50.0.

16 П.н. и.т. Minimum Integral Time

Selects integral time min. value selectable by automatic tune.

0...999.9 seconds. > **Default:** 10.0.

18 Р.с.т.т. Command Action Type

Command output regulation type.

HEAT (Heat). Heating regulation (n.o.). > **Default**

ГАС (Gas). Heating regulation with burners/fans management for gas kilns. During falling steps burners are switched off.

Г.Ф.С. (Gas Falling Steps) (GID). Heating regulation with burners/fans management for gas kilns. During falling steps burners works in ON/OFF (servo always closed).

Г.Ф.С.С. (Gas Falling Steps Servovalve) (GIDS). Heating regulation with burners/fans management for gas kilns. During falling steps gas modulation is done also by servo-valve.

COOL (Cool). Cooling regulation (n.c.).

19 с. НУ. Command Hysteresis

Hysteresis in ON/OFF or dead band in P.I.D. for command output.

-999...+999 [digit⁵] (degrees.tenths for temperature sensors).

>**Default:** 1.0.

20 Р.б. Proportional Band

Process inertia in units (Ex: if temperature in °C)

0 ON/OFF if also т. и. equal to 0. > **Default.**

1...9999 [digit⁵] (degrees.tenths for temperature sensors).

21 т. и. Integral Time

Process inertia in seconds.

0.0...999.9 seconds. 0 disabled integral. > **Default:** 0.0.

22 *t.d.* Derivative Time

Normally ¼ of integral time.

0.0...999.9 seconds. 0 disabled integral. > **Default:** 0.0.

23 *t.c.* Cycle Time

Cycle time (for P.I.D. on contactor 10"/15", for P.I.D. on SSR 1"). For time-proportioned valves see Par. 43.

1...300 seconds. > **Default:** 10.

24 *l.l.o.p.* Lower Limit Output Percentage

Selects min. value for command output percentage.

0...100% > **Default:** 0%.

25 *u.l.o.p.* Upper Limit Output Percentage

Selects max. value for command output percentage.

0...100% > **Default:** 100%.

26 *c. S.E.* Command State Error

Contact status for command output in case of error.

o.c. (Open Contact) > **Default**

c.c. (Contact closed).

27 *digit. i.* Digital Input

Digital input functioning.

d i5. (Disabled). > **Default.**

oPEn Temporary regulation lock input (holding cycle, *oPEn* on display and command output switching off).

EPEU. (Emergency) Emergency input: device stops. It visualizes *EPEU.* with active buzzer until pressing OK.

Hold Cycle pause with setpoint modifiable by keyboard.

r.cY.1 (Run Cycle 1) active **RUN** input: cycle 1 starts

r.cY.2 (Run Cycle 2) active **RUN** input: cycle 2 starts

r.cY.3 (Run Cycle 3) active **RUN** input: cycle 3 starts

r.cY.4 (Run Cycle 4) active **RUN** input: cycle 4 starts

r.cY.5 (Run Cycle 5) active **RUN** input: cycle 5 starts

r.L.cY (Run Last Cycle) active **RUN** input: starts the last cycle done

r.tHE. (Run Thermoregulator) active **RUN** input: thermoregulator function starts

r.MAN. (Run Manual) active **RUN** input: manual mode starts

tunE Input for manual autotuning function

28 d.i.c.t. Digital Input Contact Type:

- o.c. (Open Contact)
- c.c. (Contact closed) > **Default**

29 u.i.d.2 Visualization Display 2

Set visualization on display 2 during a cycle.

- E.St.S. (End Step Setpoint) Operating step end temperature
- r.SP_u (Real Setpoint) Updated according to the selected gradient
- c.Y.n.u. (Cycle Number) Number of operating cycle. > **Default.**
- St.n.u. (Step Number) Number of operating step
- t.i.n.E Time elapsed from cycle start
- o.u.t.P. (Output Percentage)

30 d.E.St. Delaied Start

Enables initial waiting for delayed start of cycle.

- d.i.S. (Disabled) Initial waiting disabled. > **Default.**
- E.n. (Enabled) Initial waiting selectable by the user.

31 S.SP_u Starting Setpoint

Enables cycle starting setpoint to guarantee the programmed gradient for the first step.

- d.i.S. (Disabled) Cycle starting setpoint disabled. > **Default.**
- E.n. (Enabled) Cycle starting setpoint selectable by the user.
- E.n.A.t. (Enabled Ambient Temperature) Fixed cycle starting setpoint (25°C for temperature sensors and 0 for linear sensors).

32 SP.F_u. Special Functions

Enables simple thermoregulator function and manual setting of output percentage.

- d.i.S. (Disabled) No function available. > **Default.**
- t.H.E.r. (Thermoregulator) Enables simple thermoregulator function.
- n.A.n. (Manual) Enables manual mode.
- t.H.n.A. (Thermoregulator and Manual) Enables both simple thermoregulator and manual function.

33 H.L.d.F. Hold Function

Enables "Hold" function; allows to hold the cycle and modify setpoint by keyboard. The same function **NOT** have to be enabled on Par. 27 d.G.t. i.

- d.i.S. (Disabled) "Hold" function disabled. > **Default.**
- E.n. (Enabled) "Hold" function enabled.

34 c.Y.A_u. Cycles Available

Selects number of available cycles.

- 1...15 cycles. > **Default: 15.**

35 *b.P.r.c.* Block Programming Cycles

Selects number of cycles that the user cannot modify, to avoid wrong programming.

Ex.: selecting 3 the programming of first 3 cycles is locked.

0...15 locked cycles. > **Default:** 0.

36 *U.t.S.E.* Waiting Time Step End

Selects time for step end waiting in hh.mm.

00.00 Step end waiting excluded

00.01...24.00 hh.mm. > **Default:** 01.00.

37 *Π.G.S.E.* Max. Gap Step End

Selects max. gap for step end waiting activation. When the difference between setpoint and process is lower than this parameter, controller switch to the next step (also without waiting time programmed into parameter 36 *U.t.S.E.*

0...200 [digit¹] (degrees.tenths for temperature sensors). > **Default:** 5.

38 *r.i.c.Y.* Recovery Interrupted Cycle

Enables interrupted cycle recovery function.

0 Cycle recovery disabled

1 Cycle recovery enabled with automatic gradient > **Default.**

2...9999 [digit¹]. Select recovery gradient (rising).

39 *b.u.S.t.* Burners Start Time

Time for burners start. Defines the time elapsed between the burner command activation and the effective flame switch on.

00.00...15.00 mm.ss. > **Default:** 01.00.

40 *t.S.o.b.* Threshold Switch Off Burners

Defines deviation threshold above the setpoint over which the burners are switched off.

0...200 [digit¹] (degrees.tenths for temperature sensors). > **Default:** 30.

41 *b. HY* Burners Hysteresis

Defines hysteresis for burners command.

-999...999 [digit¹] (degrees.tenths for temperature sensors). > **Default:** 5.0.

42 *t.S.o.F.* Threshold Switch Off Fans

Defines deviation below the setpoint over which the fans are switched off during falling steps. In GFS (GID) function, at this threshold burners are switched on instead that swiched off. When exceeding command setpoint, burners will switch off.

0...200 [digit¹] (degrees.tenths for temperature sensors). > **Default:** 10.

⁶ The display of the decimal point depends on the setting of parameters *SEn*, and *d.P.*

43 *VAL.T.* Valve Time

Time for open/close servo-valve (value declared by servo-valve manufacturer).
Not allowed for feedback valves (potentiometer).
0...300 seconds. > **Default: 60.**

44 *FE.P.O.* Feedback Potentiometer

Enables reading of feedback potentiometer for motorized valves on input AI2.
Setting *P.O.C.R.*, when exit configuration, valve will be completely open and then closed to allow the controller storing feedback potentiometer limits.
d.i.S. (Disabled). > **Default.**
E.n. (Enabled).
P.O.C.R. (Calibration Potentiometer). Backs to *E.n.* when procedure ends.

45 *AL.1* Alarm 1

Alarm 1 selection. (see paragraph 12)
d.i.S. (Disabled). > **Default.**
A.AL. (Absolute Alarm). Absolute Alarm, referring to the process.
b.AL. (Band Alarm). Command setpoint \pm band.
H.d.AL. (High Deviation Alarm). Command setpoint + deviation.
L.d.AL. (Low Deviation Alarm). Command setpoint - deviation.
A.c.S.P. (Absolute Command Setpoint Alarm). Referring to the setpoint.
St.AL. (Start Alarm). Active in **RUN**.
End.A. (End Alarm). Active at cycle end.
A.o.r.S. (Auxiliary Output Related to the Step). ON/OFF at each step.
A.o.r.M. (Auxiliary Output Rising Maintenance). Auxiliary output active for rising and holding steps.
A.o.FA. (Auxiliary Output Falling). Auxiliary output active for falling steps.
burn (Burners). Burner output for gas functioning.
FAN5 (Fans). Fans output for gas functioning.
cool (Cooling). Actuator output for cooling during double loop functioning.
A.AL.r. (Absolute Alarm active in **RUN**).

46 *A.I.S.O.* Alarm 1 State Output

Selects contact type for alarm 1 output.
n.o. (Normally Open). > **Default.**
n.c. (Normally Closed).

47 *A.L.T.H.* Alarm 1 Threshold

Selects setpoint value for alarm 1.
-999...+9999 [digit⁸] (degrees.tenths for temperature sensors). > **Default: 0.**

48 *A.I.HY* Alarm 1 Hysteresis

Selects hysteresis for alarm 1.
-999...+999 [digit³] (degrees.tenths for temperature sensors). > **Default: 1.0.**

49 *A.1.5.E.* Alarm 1 State Error

Contact status for alarm 1 output in case of error.

- o.c.* (Open Contact) > **Default**
- c.c.* (Contact closed)

50 *A.1.L.d.* Alarm 1 Led

Defines led **A1** status corresponding to relevant contact.

- o.c.* (Open Contact)
- c.c.* (Contact closed) > **Default**

51 *A.1.A.E.* Alarm 1 Action Type

Type: Defines alarm 1 action type on operating cycle.

- n.o.a.c.* (No Action). Changes only output related to the alarm > **Default**.
- E.c.y.s.* (End Cycle Signal). Cycle ends (STOP) with acoustic and visual signalling. Changes output related to the alarm, buzzer sounds and on display flashes *AL*, until pressing OK.
- A.u.s.i.* (Audible Signal). Only acoustic signalling: buzzer sounds.

52 *AL. 2* Alarm 2

Alarm 2 selection.

- d.i.s.* (Disabled). > **Default**.
- A.AL.* (Absolute Alarm). Referring to the process.
- b.AL.* (Band Alarm). Command setpoint \pm band.
- H.d.AL.* (High Deviation Alarm). Command setpoint + deviation
- L.d.AL.* (Low Deviation Alarm). Command setpoint - deviation
- A.c.S.P.* (Absolute Command Setpoint Alarm). Referring to the setpoint.
- S.t.AL.* (Start Alarm). Active in **RUN**.
- E.n.d.AL.* (End Alarm). Active at cycle end.
- A.o.r.S.* (Auxiliary Output Related to the Step). ON/OFF at each step.
- A.o.r.M.* (Auxiliary Output Rising Maintenance). Auxiliary output active for rising and holding steps.
- A.o.FA.* (Auxiliary Output Falling). Auxiliary output active for falling.
- burn* (Burners). Burner output for gas functioning.
- FANs* (Fans). Fans output for gas functioning.
- cool* (Cooling). Actuator output for cooling during double loop functioning.
- A.AL.r.* (Absolute Alarm active in **RUN**). (see paragraph 12)

53 *a.2.5.o.* Alarm 2 State Output

Selects contact type for alarm 2 output.

- n.o.* (Normally Open). > **Default**.
- n.c.* (Normally Closed).

54 *A.2.t.H.* Alarm 2 Threshold

Selects setpoint value for alarm 2.

-999...+9999 [digit⁸] (degrees for temperature sensors). > **Default: 0**.

55 *A.2.H4.* Alarm 2 Hysteresis

Selects hysteresis for alarm 2.

-999...+999 [digit⁶] (degrees.tenths for temperature sensors). > **Default:** 1.0.

56 *A.2.5.E.* Alarm 2 State Error

Contact status for alarm 2 output in case of error.

o.c. (Open Contact) > **Default**

c.c. (Contact closed)

7 *A.2.L.d.* Alarm 2 Led

Defines led **A2** status corresponding to relevant contact.

o.c. (Open Contact)

c.c. (Contact closed) > **Default**

58 *A.2.A.E.* Alarm 2 Action Type

Defines alarm 2 action type on operating cycle.

n.o.a.c. (No Action). Changes only output related to the alarm. > **Default.**

E.c.y.s. (End Cycle Signal). Cycle ends (STOP) with acoustic and visual signalling. Changes output related to the alarm, buzzer sounds and on display flashes *AL 2* until pressing OK.

A.u.s.i. (Audible Signal). Only acoustic signalling: buzzer sounds.

59 *AL 3* Alarm 3

Alarm 3 selection (see paragraph 12)

d.i.s. (Disabled). > **Default.**

A.AL. (Absolute Alarm). Referring to the process.

b.AL. (Band Alarm). Command setpoint ± band.

H.d.AL. (High Deviation Alarm). Command setpoint + deviation.

L.d.AL. (Low Deviation Alarm). Command setpoint - deviation.

A.c.s.A. (Absolute Command Setpoint Alarm). Referring to the setpoint.

S.t.AL. (Start Alarm). Active in **RUN**.

End.A. (End Alarm). Active at cycle end.

A.o.r.s. (Auxiliary Output Related to the Step). ON/OFF at each step.

A.o.r.π. (Auxiliary Output Rising Maintenance). Auxiliary output active for rising and holding steps

A.o.FA. (Auxiliary Output Falling). Auxiliary output active for falling steps.

burn (Burners). Burner output for gas functioning.

FRnS (Fans). Fans output for gas functioning.

cool (Cooling). Actuator output for cooling during double loop functioning.

A.AL.r. (Absolute Alarm active in **RUN**).

60 *A.3.5.o.* Alarm 3 State Output

Selects contact type for alarm 3 output.

n.o. (Normally Open). > **Default.**

n.c. (Normally Closed).

61 *R.3.LH.* Alarm 3 Threshold

Selects setpoint value for alarm 3.

-999...+9999 [digit²] (degrees for temperature sensors). > **Default:** 0.

62 *R.3.HY.* Alarm 3 Hysteresis

Selects hysteresis for alarm 3.

-999...+999 [digit²] (degrees.tenths for temperature sensors). > **Default:** 1.0.

63 *R.3.S.E.* Alarm 3 State Error

Contact status for alarm 3 output in case of error.

o.c. (Open Contact) > **Default**

c.c. (Contact closed)

64 *R.3.Ld.* Alarm 3 Led

Defines led **A3** status corresponding to relevant contact.

o.c. (Open Contact)

c.c. (Contact closed) > **Default**

65 *R.3.A.L.* Alarm 3 Action Type

Defines alarm 3 action type on operating cycle.

no.A.c. (No Action). Changes only output related to the alarm. > **Default.**

E.c.y.S. (End Cycle Signal). Cycle ends (STOP) with acoustic and visual signalling. Changes output related to the alarm, buzzer sounds and on display flashes *AL 3*, until pressing OK.

A.u.S.i. (Audible Signal). Only acoustic signalling: buzzer sounds.

66 *AL 4* Alarm 4

Alarm 4 selection (see paragraph 12)

d.i.S. (Disabled). > **Default.**

A. AL. (Absolute Alarm). Referring to the process

b. AL. (Band Alarm). Command setpoint \pm band.

H.d.AL. (High Deviation Alarm). Command setpoint + deviation.

L.d.AL. (Low Deviation Alarm). Command setpoint - deviation.

A.c.S.A. (Absolute Command Setpoint Alarm). Referring to the setpoint.

St.AL. (Start Alarm). Active in **RUN**.

End.A. (End Alarm). Active at cycle end.

A.o.r.S. (Auxiliary Output Related to the Step). ON/OFF at each step.

A.o.r.lf. (Auxiliary Output Rising Maintenance). Auxiliary output active for rising and holding steps.

A.o.FA. (Auxiliary Output Falling). Auxiliary output active for falling steps.

burn (Burners). Burner output for gas functioning.

FAN5 (Fans). Fans output for gas functioning.

cool (Cooling). Actuator output for cooling during double loop functioning.

AL.r. (Absolute Alarm active in **RUN**).

67 a4.5.o. Alarm 4 State Output

Selects contact type for alarm 4 output.

n.o. (Normally Open). > **Default.**

n.c. (Normally Closed).

68 A4.tH. Alarm 4 Threshold

Selects setpoint value for alarm 4.

-999...+9999 [digit⁴] (degrees for temperature sensors). > **Default: 0.**

69 A4.HY. Alarm 4 Hysteresis

Selects hysteresis for alarm 4.

-999...+999 [digit] (degrees.tenths for temperature sensors). > **Default: 1.0.**

70 A4.5.E. Alarm 4 State Error

Contact status for alarm 4 output in case of error.

o.c. (Open Contact) > **Default**

c.c. (Contact closed)

71 A4.Ld. Alarm 4 Led

Defines led A4 status corresponding to relevant contact.

o.c. (Open Contact)

c.c. (Contact closed) > **Default**

72 A4.A.t. Alarm 4 Action Type

Defines alarm 4 action type on operating cycle.

n.o.A.c. (No Action). Changes only output related to the alarm. > **Default.**

E.c.y.s. (End Cycle Signal). Cycle ends (STOP) with acoustic and visual signalling. Changes output related to the alarm, buzzer sounds and on display flashes AL 4, until pressing OK.

A.u.s.i. (Audible Signal). Only acoustic signalling: buzzer sounds

73 c.o.o.F. Cooling Fluid

Defines cooling fluid type.

A.i.r > **Default**

o.i.L

H2o

74 P.b.M. Proportional Band Multiplier

1.00...5.00. > **Default: 1.00.**

75 o.v.d.b. Overlap/Dead Band

-20.0%...50.0%. > **Default: 0.0%.**

76 c.o.c.t. Cooling Cycle Time

1...300 secondi. > **Default: 10s.**

77 rEP.S. Remote Setpoint

Selects remote setpoint mode, through serial communication.

d.i.S. (Disabled). Controller operates autonomously. > **Default.**

SLvE (Slave). Controller is a slave normally in STOP: goes in **RUN** when, on master device connected to the serial, a cycle is started.

MSr (Master). Controller transmits the setpoint to all controllers connected to the serial and set as slave.

78 bd.rE. Baud Rate

Selects baud rate for serial communication.

4B r 4800 bit/s

9.6 r 9600 bit/s 38.4r 38400 bit/s

19.2r 19200 bit/s > **Default** 57.6r 57600 bit/s

28.8r 28800 bit/s 115.2 115200 bit/s

79 SE.P.S. Serial Parameters Setting

Selects data format for serial communication.

B.n.i 8 data bits, no parity, 1 stop bit. > **Default.**

B.o.i 8 data bits, odd parity, 1 stop bit.

B.E.i 8 data bits, even parity, 1 stop bit.

80 SL.Ad. Slave Address

Selects slave address for serial communication.

1...254 Address for slave functioning. > **Default:** 254.

81 SE.dE. Serial Delay

Select serial delay.

0...100 ms. > **Default:** 20ms.

82 c.FLE. Conversion Filter

Adc filter: number of means on analogue-digital conversion.

1...15 samplings > **Default:** 10.

83 v.FLE. Visualization Filter

d.i.S. (Disabled)

Ptch (Pitchfork filter) > **Default.**

F_{1.or.} (First Order)

F_{1.or.P.} (First Order with Pitchfork)

2. S.n. (2 Samples Mean)

3. S.n. (3 Samples Mean)

4. S.n. (4 Samples Mean)

5. S.n. (5 Samples Mean)

6. S.n. (6 Samples Mean)

7. S.n. (7 Samples Mean)

8. S.n. (8 Samples Mean)

9. S.n. (9 Samples Mean)

10.S.n. (10 Samples Mean)

84 rEtr. Retransmission

Retransmission for analogue output. Par. 86 and 87 define upper/lower limit of scale
d15. (Disabled). > **Default.**
c5Pv. (Command Setpoint) Retransmit the command setpoint.
Pro. (Process) Retransmit the process.

85 rEty. Retransmission Type

Select retransmission signal type.

0-10 (0...10V)
0-20 (0...20mA)
4-20 (4...20mA) > **Default.**

86 Lo.Lr. Lower Limit Retransmission

Lower limit analogue output range.

-999...+9999 [digit] (degrees.tenths for temperature sensors). > **Default: 0.**

87 uP.Lr. Upper Limit Retransmission

Upper limit analogue output range.

-999...+9999 [digit] (degrees.tenths for temperature sensors). > **Default: 1000.**

13 Alarm intervention modes

ATR421 has the possibility to program up to four alarms.

Into the following table all intervention modes are showed.

13.a Absolute alarm

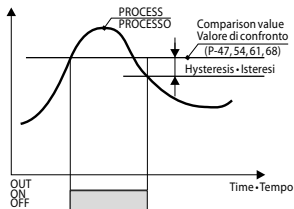

Alarm can be:

- Active over
- Active under

In the figure it is active over.

13.b Band alarm (setpoint-process)

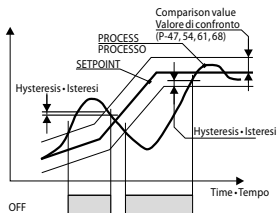

Alarm can be:

- Active outside
- Active inside

In the figure it is active outside.

13.c Deviation alarms

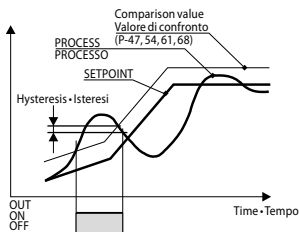

Alarm can be:

- Upper deviation
- Lower deviation

In the figure it is upper deviation.

13.d Independent alarm referring to the setpoint

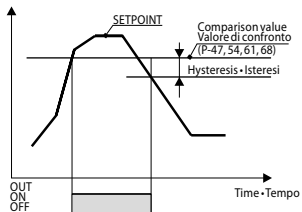

Alarm can be:

- Active over
- Active under

In the figure it is active on.

Each intervention can be related to a cycle lock and/or to an acoustic signalling.

13.e Auxiliary output related to the step

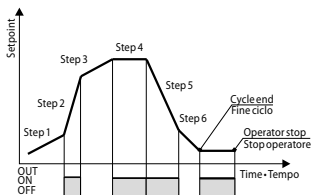

ON/OFF status of the auxiliary output is selectable for each step of each cycle. The status can be selected also at cycle end.

14 Table of Anomaly Signals

If installation malfunctions, controller will switch off regulation output and will report the anomaly. For example, controller will report failure of a connected thermocouple visualizing *E-05* (flashing) on display. For other signals see table below.

	Cause	How to do
<i>E-01</i> <i>SYS.E.</i>	Error in EEPROM cell programming.	Call Assistance
<i>E-03</i> <i>EEPE.</i>	Incorrect cycle data	Call Assistance
<i>E-04</i> <i>SYS.E.</i>	Incorrect configuration data. Possible loss instrument calibration.	Verify that configuration parameters are correct.
<i>E-05</i> <i>Prb.1</i>	Sensor connected to AI1 broken or temperature out of range.	Control connection with probes and their integrity.
<i>E-06</i> <i>Prb.2</i>	Sensor connected to AI2 broken or temperature out of range.	Control connection with potentiometer and its integrity.
<i>E-08</i> <i>SYS.E.</i>	Missing calibration.	Call Assistance
<i>E-11</i> <i>SYS.E.</i>	Cold junction sensor failure or room temperature outside of allowed limits.	Call Assistance
<i>E-16</i> <i>Pa.c.A.</i>	Feedback potentiometer for motorized valve not calibrated.	Start valve calibration procedure.

Notes / Updates

Table of configuration parameters

1	c.out	Command Output	27
2	SEn.	Sensor	28
3	d.P.	Decimal Point	28
4	LoL.i.	Lower Linear Input	29
5	uP.L.i.	Upperr Linear Input	29
6	o.cAL.	Offset Calibration	29
7	G.cAL.	Gain Calibration	29
8	LoL.S.	Lower Limit Setpoint	29
9	uP.L.S.	Upper Limit Setpoint	29
10	dEGr.	Degree	29
11	tunE	Tune	29
12	S.d.t.u.	Setpoint Deviation Tune	29
13	M.G.t.u.	Max Gap Tune	30
14	Mn.P.b.	Minimum Proportional Band:	30
15	Mx.P.b.	Maximum Proportional Band	30
16	Mn.i.t.	Minimum Integral Time	30
18	Act.t.	Command Action Type	30
19	c.HY.	Command Hysteresis	30
20	P.b.	Proportional Band	30
21	t.i.	Integral Time	30
22	t.d.	Derivative Time	31
23	t.c.	Cycle Time	31
24	LL.o.P.	Lower Limit Output Percentage	31
25	u.Lo.P.	Upper Limit Output Percentage	31
26	c.S.E.	Command State Error	31
27	dGt.i.	Digital Input	31
28	d.i.c.t.	Digital Input Contact Type:	32
29	v.i.d.2	Visualization Display 2	32
30	dE.St.	Delaied Start	32
31	S.SP.u	Starting Setpoint	32
32	SP.F.u.	Special Functions	32
33	Hld.F.	Hold Function	32
34	cYAv.	Cycles Available	32
35	b.Pr.c.	Block Programming Cycles	33
36	U.t.S.E.	Waiting Time Step End	33
37	M.G.S.E.	Max. Gap Step End	33
38	r.i.cY.	Recovery Interrupted Cycle	33
39	bu.S.t.	Burners Start Time	33
40	t.S.o.b.	Threshold Switch Off Burners	33
41	b.HY.	Burners Hysteresis	33
42	t.S.o.F.	Threshold Switch Off Fans	33
43	vAL.t.	Valve Time	34
44	FE.P.o.	Feedback Potentiometer	34

45	<i>AL1</i>	Alarm 1	34
46	<i>A1S.o.</i>	Alarm 1 State Output	34
47	<i>A1tH.</i>	Alarm 1 Threshold	34
48	<i>A1Hy.</i>	Alarm 1 Hysteresis	34
49	<i>A1S.E.</i>	Alarm 1 State Error	35
50	<i>A1Ld.</i>	Alarm 1 Led	35
51	<i>A1A.t.</i>	Alarm 1 Action Type	35
52	<i>AL 2</i>	Alarm 2	35
53	<i>a2S.o.</i>	Alarm 2 State Output	35
54	<i>A2tH.</i>	Alarm 2 Threshold	35
55	<i>A2Hy.</i>	Alarm 2 Hysteresis	36
56	<i>A2S.E.</i>	Alarm 2 State Error	36
7	<i>A2Ld.</i>	Alarm 2 Led	36
58	<i>A2A.t.</i>	Alarm 2 Action Type	36
59	<i>AL 3</i>	Alarm 3	36
60	<i>A3S.o.</i>	Alarm 3 State Output	36
61	<i>A3tH.</i>	Alarm 3 Threshold	37
62	<i>A3Hy.</i>	Alarm 3 Hysteresis	37
63	<i>A3S.E.</i>	Alarm 3 State Error	37
64	<i>A3Ld.</i>	Alarm 3 Led	37
65	<i>A3A.t.</i>	Alarm 3 Action Type	37
66	<i>AL 4</i>	Alarm 4	37
67	<i>a4S.o.</i>	Alarm 4 State Output	38
68	<i>A4tH.</i>	Alarm 4 Threshold	38
69	<i>A4Hy.</i>	Alarm 4 Hysteresis	38
70	<i>A4S.E.</i>	Alarm 4 State Error	38
71	<i>A4Ld.</i>	Alarm 4 Led	38
72	<i>A4A.t.</i>	Alarm 4 Action Type	38
73	<i>coo.F.</i>	Cooling Fluid	38
74	<i>P.b.M.</i>	Proportional Band Multiplier	38
75	<i>ou.d.b.</i>	Overlap/Dead Band	38
76	<i>co.c.t.</i>	Cooling Cycle Time	38
77	<i>rEt.S.</i>	Remote Setpoint	39
78	<i>bd.r.t.</i>	Baud Rate	39
79	<i>SE.P.S.</i>	Serial Parameters Setting	39
80	<i>SLAd.</i>	Slave Address	39
81	<i>SE.dE.</i>	Serial Delay	39
82	<i>c.FLt.</i>	Conversion Filter	39
83	<i>v.FLt.</i>	Visualization Filter	39
84	<i>rEtr.</i>	Retransmission	40
85	<i>rE.tY.</i>	Retransmission Type	40
86	<i>Lo.L.r.</i>	Lower Limit Retransmission	40
87	<i>uPL.r.</i>	Upper Limit Retransmission	40



Read carefully the safety guidelines and programming instructions contained in this manual before using/connecting the device.

Prima di utilizzare il dispositivo leggere con attenzione le informazioni di sicurezza e settaggio contenute in questo manuale.



RoHS 
Compliant



PIXSYS s.r.l.

www.pixsys.net

sales@pixsys.net - support@pixsys.net

online assistance: <http://forum.pixsys.net>



2300.10.136-RevD

Software Rev. 1.11

030117