



# Greyline OCF 6.1

**Instruction Manual**

Manual Version A.2.0



Note: This page has been left blank intentionally.

**CONTENTS**

CONNECTIONS .....	4
KEYPAD SYSTEM.....	6
CALIBRATION MENU .....	7
ICONS .....	8
MAIN DISPLAY.....	9
MESSAGE ICON.....	9
STATUS.....	9
PASSWORD.....	10
UNITS/MODE .....	11
CALIBRATION.....	13
CHANNEL SETUP .....	16
RELAY PARAMETERS.....	19
DATA LOGGING.....	20
SPECIAL FUNCTIONS .....	22
SENSOR MOUNTING METHODS .....	24
ERROR/WARNING MESSAGES.....	29
FIELD TROUBLESHOOTING .....	30
APPLICATIONS HOTLINE.....	34
PRODUCT RETURN PROCEDURE .....	34
APPENDIX A - OPTIONS.....	36
MODBUS® COMMUNICATION .....	40
CONVERSION GUIDE .....	55
SPECIFICATIONS.....	56

**IMPORTANT NOTE:** This instrument is manufactured and calibrated to meet product specifications. Please read this manual carefully before installation and operation. Any unauthorized repairs or modifications may result in a suspension of the warranty.

If this product is not used as specified by the manufacturer, protection may be impaired.

Available in Adobe Acrobat pdf format

**CONNECTIONS:**

POWER INPUT: The standard model requires AC power input between 100 to 240 VAC 50/60Hz. No adjustments are necessary for voltages within this range.

Optional DC: 9-32 VDC. Connect to + and - terminals.

Optional Thermostat and Heater modules are available rated for 115 VAC or 230 VAC.

IMPORTANT NOTE: To comply with CSA/UL electrical safety standards, AC power input and relay connection wires must have conduit entry to the instrument enclosure. Installation requires a switch, overcurrent fuse or circuit breaker in the building (in close proximity to the equipment) that is marked as the disconnect switch.



Risk of electric shock. Loosen cover screw to access connections. Only qualified personnel should access connections.

Note: Use of instrumentation over 40°C ambient requires special field wiring.

**CONNECTIONS**

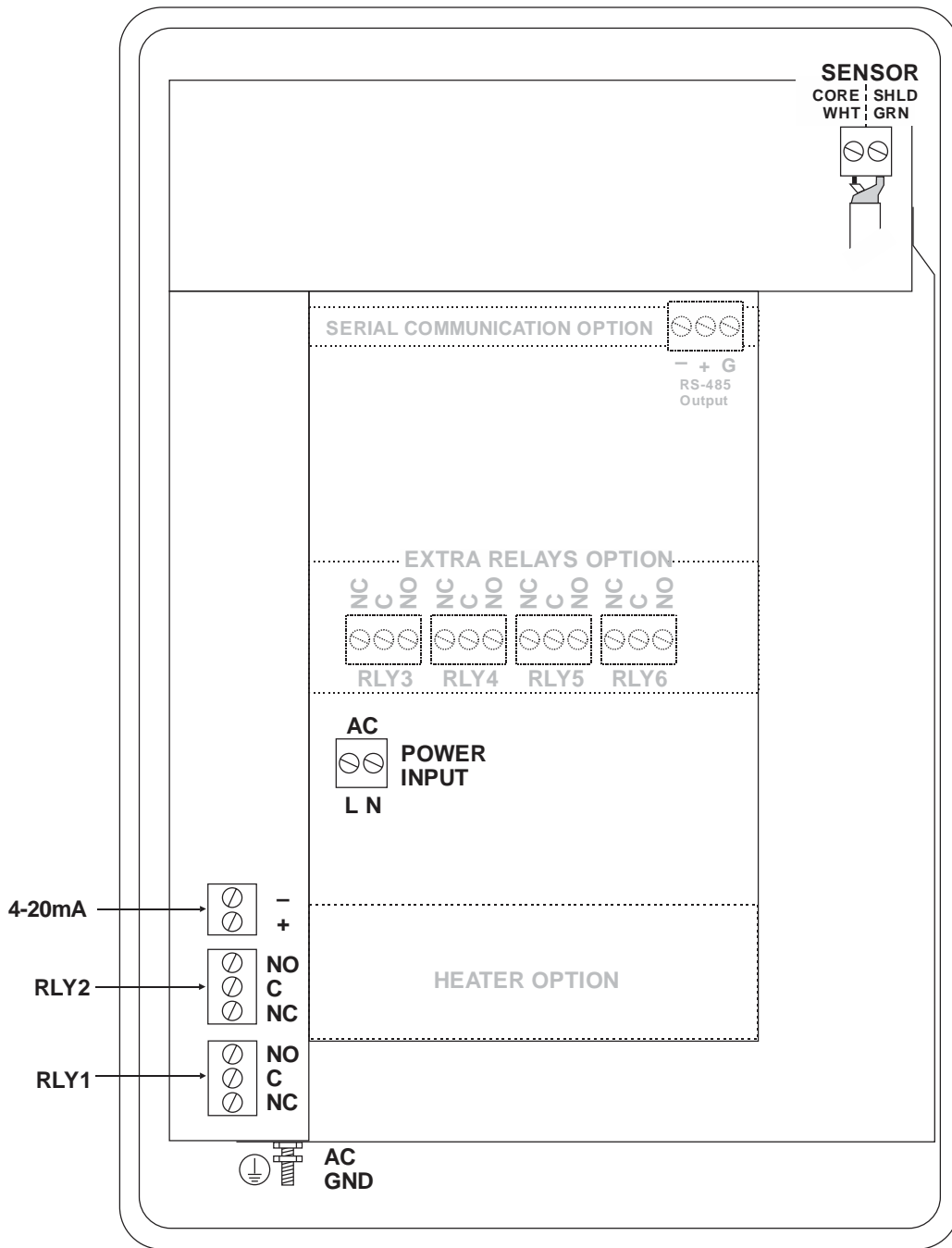

**KEYPAD SYSTEM**

The OCF 6.1 uses a menu system. Arrows show the four directions to leave a menu box. Press a key to move to the next item in the direction shown. Move the cursor (highlighted) under numerals and increase or decrease numerals with the ▲ and ▼ keys.

To store calibration values permanently (even through power interruptions), press ✓.

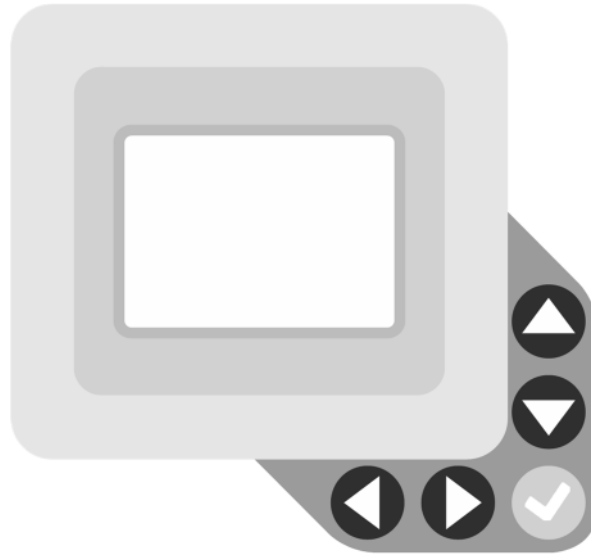

**CALIBRATION MENU**

```

--Tech's Menu-----
▶Dist = Max      No
Barrier         No
Standpipe      No
Long Pulse     No
Gain           115
    
```

This menu is accessed by pressing **✓** & **▶** simultaneously.

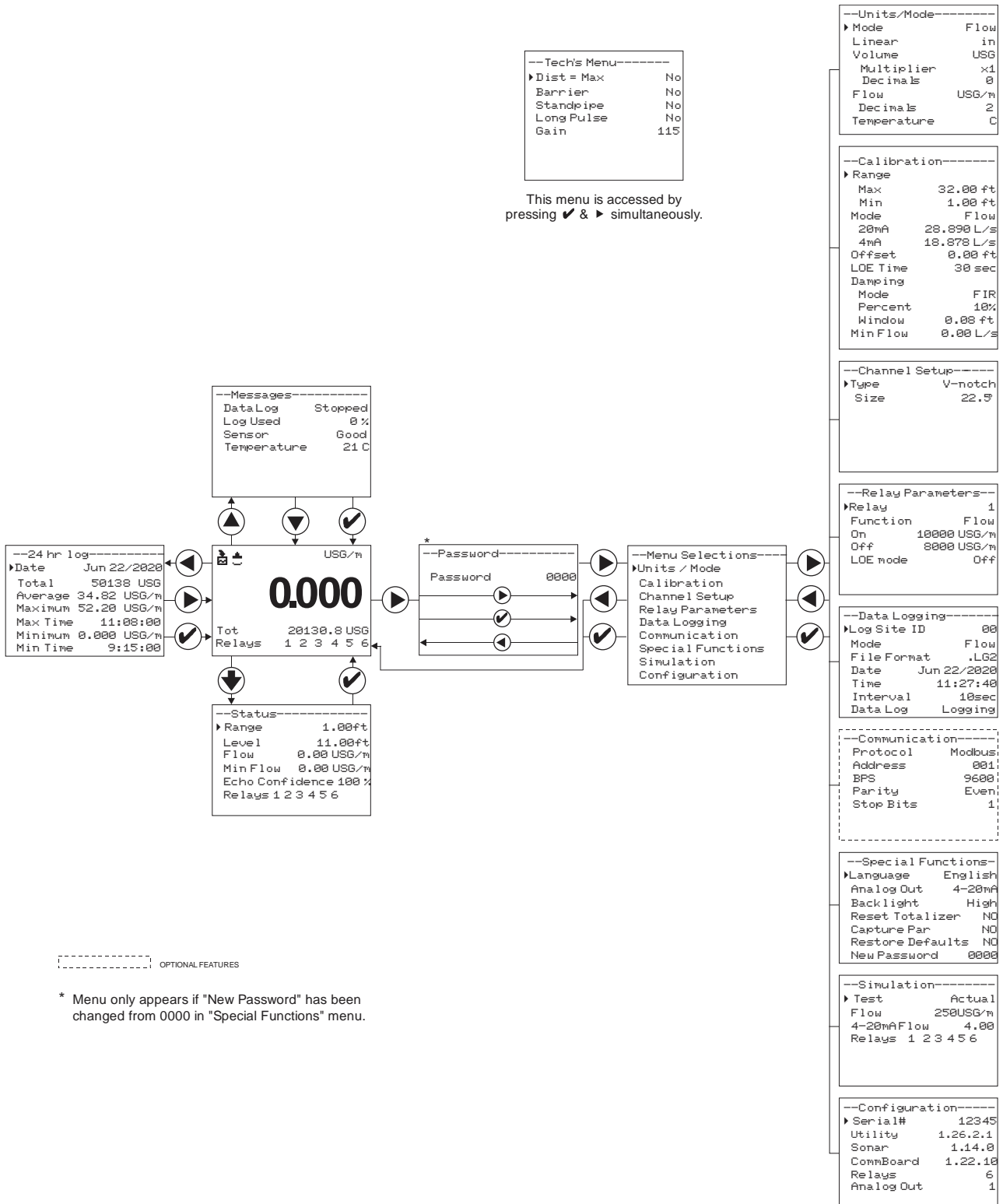

OPTIONAL FEATURES

\* Menu only appears if "New Password" has been changed from 0000 in "Special Functions" menu.

**ICONS**



Message waiting. Press ▲.



Data logging off.



Data logging on.



USB file download.



File download completed.



Download Error.

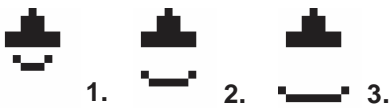

Echo OK.



Loss of Echo .

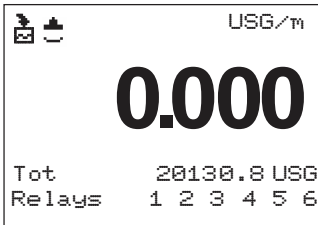

### MAIN DISPLAY

The main display shows the units selected from the Units/Mode menu, Level, Range, Flow, HRT, and Volume rate being measured, TOTALIZER and RELAY states. The OCF 6.1 will start-up with this display.



### MESSAGE ICON

Press ▲ from the main display to view status of the data logger and error/warning messages provided by the instrument. The Message Icon will appear on the main display if error messages are being generated by the instrument. Refer to the manual section Error/Warning Messages for a description. Press ✓ to return to the main display.

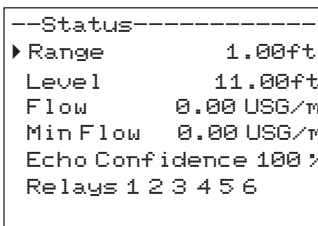

### STATUS

Press ▼ from the main display to view instrument status. Range will be displayed in linear units.

- Range**                      Displays the current range measurement. The distance between the sensor face and the surface being measured.
  
- Level**                        Displays the current level measurement. The difference between the Max Range programmed in the Calibration menu and the measured range.
  
- Flow**                         Displays the current flow rate in engineering units set in the Units/Mode menu.
  
- Min Flow**                    Displays the minimum flow rate set in the Calibration menu. Flow rates below the Min Flow will be shown as 0 on the main display.
  
- Echo Confidence**         Displays Echo Confidence in percentage. 100% is ideal, but any percentage other than 0% is normal and means that echoes are being measured. Echo Confidence less than 100% means that not all echoes are returning to the sensor, which could be because of surface turbulence, a sensor not perpendicular to the water surface, foam, grease, or vapors in the atmosphere.



--Units/Mode-----	
► Mode	Flow
Linear	in
Volume	USG
Multiplier	x1
Decimals	0
Flow	USG/m
Decimals	2
Temperature	C

## UNITS/MODE

At **Mode**, press the ► and then the ▲ or ▼ to select Flow or Velocity. Flow mode displays the flow rate in engineering units (e.g. gpm, litres/sec, etc.) Press the ✓ to store your selection then the ▼ to the next menu item.

At **Linear** press the ► key and then the ▲ or ▼ to select your units of measurement. The Linear units define what units the pipe/channel dimensions and level reading will be displayed in. Typically inches or mm is selected. Press the ✓ to store your selection then the ▼ to the next menu item.

At **Volume**, press the ► and then the ▲ or ▼ to select units for volume. Note: "bbl" denotes US oil barrels. Press the ✓ to store your selection then the ▼ to the next menu item.

At **Multiplier**, press the ► and then the ▲ or ▼ to select the totalizer multiplier. Multipliers are used when resolution down to single digit is not required, or when you don't want to convert from gallons to thousands of gallons, as an example. Press ✓ to store your selection then ▼ to the next menu item.

At **Dec imal (Volume)**, press the ► and then the ▲ or ▼ to select the number of decimal points to be present on the totalizer display on the LCD screen. Default = 0. Options = 0, 1, 2. Press the ✓ to store your selection then the ▼ to the next menu item.

```

--Units/Mode-----
▶ Mode           Flow
  Linear         in
  Volume         USG
  Multiplier     x1
  Decimals       0
  Flow           USG/m
  Decimals       2
  Temperature    C
    
```

**UNITS/MODE cont.**

At **F l o w**, press the ▶ and then the ▲ or ▼ to select the engineering units for flow rate. Press ✓ to store your selection then ▼ to the next menu item.

Available Flow Rate Engineering Units:

Abbreviation	Description	Abbreviation	Description
USG/d	US gallons per day	L/d	liters per day
USG/h	US gallons per hour	L/h	liters per hour
USG/m	US gallons per minute	L/m	liters per minute
USG/s	US gallons per second	L/s	liters per second
ft <sup>3</sup> /d	cubic feet per day	m <sup>3</sup> /d	cubic meters per day
ft <sup>3</sup> /h	cubic feet per hour	m <sup>3</sup> /h	cubic meters per hour
ft <sup>3</sup> /m	cubic feet per minute	m <sup>3</sup> /m	cubic meters per minute
ft <sup>3</sup> /s	cubic feet per second	m <sup>3</sup> /s	cubic meters per second
bbl/d	barrels per day (1 bbl = 42 USG)	IG/d	Imperial gallons per day
bbl/h	barrels per hour (1 bbl = 42 USG)	IG/d	Imperial gallons per day
bbl/m	barrels per minute (1 bbl = 42 USG)	IG/d	Imperial gallons per day
bbl/d	barrels per second (1 bbl = 42 USG)	IG/d	Imperial gallons per day
USMG/d	US million gallons per day	IMG/d	Imperial million gallons per day
USMG/h	US million gallons per hour	IMG/h	Imperial million gallons per hour
USMG/m	US million gallons per minute	IMG/m	Imperial million gallons per minute
USMG/s	US million gallons per second	IMG/s	Imperial million gallons per second

At **D e c i m a l (Flow)**, press the ▶ and then the ▲ or ▼ to select the number of decimal points to be present on the flow rate display on the LCD screen. Default = 2. Options = 0, 1, 2 or 3. Press the ✓ to store your selection then the ▼ to the next menu item.

At **T e m p e r a t u r e**, press ▶ and then ▲ or ▼ to select engineering units for temperature. Press ✓ to store your selection then ◀ to go back to the Menu.

```

--Calibration-----
▶ Range
  Max      32.00 ft
  Min      1.00 ft
  Mode     Flow
  20mA     28.890 L/s
  4mA      18.878 L/s
  Offset   0.00 ft
  LOE Time 30 sec
  Damping
  Mode     FIR
  Percent  10%
  Window   0.08 ft
  Min Flow 0.00 L/s

```

## CALIBRATION

Press ▼ to **Calibration** and ▶ to enter. Use ▼ or ▲ to position ▶ before each menu item and ▶ to enter. When settings are completed press ✓ to store and return to the Calibration menu.

**Min Range** Distance from the sensor face to highest expected level.

**Max Range** Distance from sensor to Zero level.

**MaxVol** For Volume and HRT mode only. Enter the maximum volume of the vertical or horizontal tank.

**Mode** Shows the Mode set in the Units/Mode menu. Read-only.

**20mA** Sets the 20mA output value, in engineering units set in the Units/Mode menu.

**4mA** Sets the 4mA output value, in engineering units set in the Units/Mode menu.

**Offset** Sets an Offset value, in engineering units set in the Units/Mode menu. This parameter can be used to be a one-point adjustment to the Range reading.

**LOE Time** Press ▶ and ▲ or ▼ to change the number of seconds without receiving an echo before the OCF 6.1 displays ECHO LOSS, and Control relays change state as calibrated under Relay Parameters.

Factory default is 30 seconds and is recommended for most applications, Minimum is 1 second and maximum is 99 seconds.

```

--Calibration-----
▶ Range
  Max      32.00 ft
  Min      1.00 ft
  Mode     Flow
  20mA     28.890 L/s
  4mA      18.878 L/s
  Offset   0.00 ft
  LOE Time 30 sec
  Damping
  Mode     FIR
  Percent  10%
  Window   0.08 ft
  Min Flow 0.00 L/s
    
```

**CALIBRATION cont.**

**Damping**

Choose between OFF, FIR (Default), or LOW PASS.

When measured flows are outside the Window of the running average, the FIR filter will reduce the damping average so that a fast response can be made to the sudden change in flow rate.

The LOW PASS filter will ignore measured flow rates outside the Window, while holding the running average, until there are enough data points outside the Window to cause a step-response to the new measured value.

While measured flows are within the Window of the running average, both the FIR and LOW PASS filter behave the same.

**Percent**

Set the damping value for level reading. Lower values provide fast response to changing levels, and higher values provide a slower response. Factory default value is 10%.

**Window**

The Window sets a boundary around the running average, where if the measured value falls outside the window, the meter will make a more rapid response to the new value (FIR), or will hold the last reading until enough values are outside the window and then make a step response to the new value (LOW PASS).

Press ✓ to return to Menu Selections.

**CALIBRATION**  
*- for Open Channel Flow*

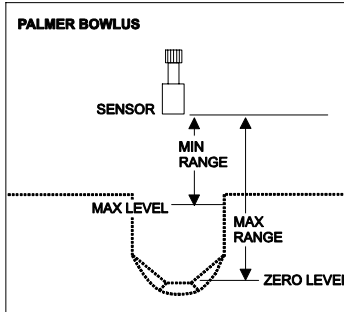

1. Before starting the calibration determine:

- a) MAX RANGE = \_\_\_\_\_  
 (Maximum range = distance from the Sensor to Zero flow point)
- b) MAX LEVEL = \_\_\_\_\_  
 (Maximum level of flow through flume or weir)
- c) MIN RANGE = \_\_\_\_\_  
 (Distance from sensor to Max Level)  
 Minimum range = MAX RANGE - MAX LEVEL  
 (must be at least 8" / 20.3 cm depending on sensor model).

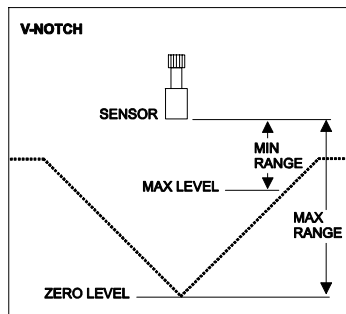

2. Check the maximum range with the sensor installed by:

- a) When liquid is at zero level press  to view the Range reading in the Status menu. Use this range measured by the OCF 6.1 as the Max Range setting.  
 or
- b) Carefully measure distance from sensor to zero level with a tape measure, and use this measurement as the Max Range setting.

NOTE: The OCF 6.1 will not detect targets beyond user entered Max Range.

**CHANNEL SETUP**

```

--Channel Setup-----
▶Type      V-notch
           Custom
           Venturi
           Khafagi
           Rect Weir w/EC
           Rect Weir
           Trapezoidal
           RBC
           Montana
           Cutthroat
           HL Flume
           H Flume
           HS Flume
           Leopld-Lagco
           Palmer Boullus
           Parshall
    
```

```

--Channel Setup-----
▶Type      V-notch
Size      22.5
          120°
          90°
          60°
          45°
          30°
    
```

```

--Channel Setup-----
▶Type      Venturi
    
```

```

--Channel Setup-----
▶Type      Khafagi
Width      0.000in
    
```

```

--Channel Setup-----
▶Type      Rect Weir w/EC
Width      0.000in
    
```

```

--Channel Setup-----
▶Type      Rect Weir
Width      0.000in
    
```

```

--Channel Setup-----
▶Type      Trapezoidal
Size      Extra large 60
          Large 60
          Small 60
          12in 45° SRCRC
          2in 45° WSC
          8in 60°
    
```

```

--Channel Setup-----
▶Type      RBC
Size      50mm
          200mm
          150mm
          100mm
          75mm
    
```

```

--Channel Setup-----
▶Type      Montana
Size      50mm
          200mm
          150mm
          100mm
          75mm
    
```

```

--Channel Setup-----
▶Type      Cutthroat
Size      18" x 1"
          100" x 72"
          100" x 48"
          100" x 24"
          100" x 12"
          54" x 24"
          54" x 12"
          54" x 6"
          54" x 3"
          36" x 16"
          36" x 8"
          36" x 4"
          36" x 2"
          18" x 8"
          18" x 4"
          18" x 2"
    
```

**CHANNEL SETUP cont.**

```

--Channel Setup-----
▶Type      HL Flume
Size      3.0ft
           4.0ft
    
```

```

--Channel Setup-----
▶Type      H Flume
Size      0.5ft
           4.5ft
           3.0ft
           2.5ft
           2.0ft
           1.5ft
           1.0ft
           0.75ft
    
```

```

--Channel Setup-----
▶Type      HS Flume
Size      0.4ft
           1.0ft
           0.8ft
           0.6ft
           0.4ft
    
```

```

--Channel Setup-----
▶Type      Leopld-Lagco
Size      36in
           30in
           24in
           18in
           12in
           10in
           8in
           6in
    
```

```

--Channel Setup-----
▶Type      Palmer Bowlus
Size      48in
           42in
           36in
           30in
           27in
           24in
           21in
           18in
           15in
           12in
           10in
           8in
           6in
           4in
    
```

```

--Channel Setup-----
▶Type      Parshall
Size      12ft
           10ft
           8ft
           6ft
           5ft
           4ft
           3ft
           2ft
           18in
           12in
           9in
           6in
           3in
           2in
           1in
    
```

**CHANNEL SETUP cont.**

```

--Channel Setup-----
▶Type          Custom
K              0.0000
n              0.0000
    
```

**CHANNEL SETUP**

Type

Custom. Used to configure the OCF for a flume/weir type not already selectable in the meter.

K & n

Format: Flow = K \* H^n; Where H = head

Use the Find K&n software (included on Flash drive shipped with meter) to determine the K&n values to use. The K&n software requires that you enter up to 10 head points and the corresponding flow rates for each point. A curve fit is performed, and the software provides the K and n values to program into the meter. You can also contact a Pulsar Measurement technician for these values.

**IMPORTANT:** The OCF requires that the K & n coefficients are from a flow equation where flow is in units of CFS, and head in units of feet. If you determined a K & n coefficient outside the use of the Find K&n software, be sure that the coefficients are in these units, otherwise you will need to convert them before entering them in the meter. The Units/Mode settings in the meter can be configured to whatever units you desire for flow rate and total. The meter will automatically convert the K&n in CFS to the programmed units in the Units/Mode menu for the flow rate and totalizer display.

**IMPORTANT:** If you are uncertain about how to convert your K and n constants please contact our technical support team and we'll be happy to assist.

Example: For a 2 foot Parshall flume, the discharge equation for a flow rate in GPM, and head in feet, is  $GPM = 3590 * H^{1.55}$ . Since head is already in feet, we only need to convert GPM to CFS. 1 CFS = 448.8 GPM, so dividing by 448.8 give us  $CFS = 8.0 * H^{1.55}$ . This is the equation we would enter into the OCF 6.1 for this flume.

```

--Relay Parameters--
▶Relay                1
Function              Flow
On                   10000 USG/m
Off                   8000 USG/m
LOE mode              Off

```

## RELAY PARAMETERS

**Relay** Press ▶ and ▼ or ▲ to select a relay (2 relays are standard, 4 additional are optional).

**Function** Press ▼ or ▲ to select Off, Temperature, Pulse or Flow.

**Temperature** Air temperature at the sensor location. Press ▼ and ▶ and set the relay On and Off for specific temperatures.

**Pulse** Press ▼ and set digits to the flow volume increment required between relay pulses. Use this feature for remote samplers, chlorinators or totalizers. Minimum time between pulses is 2.25 seconds and pulse duration is 350 milliseconds.

**Flow** Press ▼ to Mode and ▶ to select Pump, Low Alarm or Hi Alarm.

Note: Function setting Flow will change according to selections made under Units /Mode eg Level, Range, Volume or HRT.

Press ✓ to return to Menu Selections.

**LOE mode** Set relay state for 'echo loss' event (On, Off or Hold)

```

--Data Logging-----
▶Log Site ID      00
                  99
Mode              Flow
File Format       .LG2
Date             Jun 22/2020
Time             11:27:40
Interval         10sec
                  60min
                  30min
                  15min
                  10min
                  5min
                  2min
                  1min
                  30sec
Data Log         Start
                  Stop
                  Delete
    
```

## DATA LOGGING

### Setup

Select Data Logging from Menu Selections.

**Log Site ID** Enter a number from 00 to 99. The site ID will become part of the downloaded file name to help distinguish downloads from different instruments. Press ✓ to store the setting.

**Mode** Select Level, Range, Flow, HRT and Volume. Flow (e.g. USGPM or l/sec). Press ✓ to store the setting.

**File Format** Choose .LG2 to download data in .lg2 format for viewing on Greyline Logger Software. Choose .CSV to download data in .csv format for import directly to Excel. This menu option can be changed at any time without adversely affecting existing data.

**Date** Press ▲ or ▼ to scroll and select Month, Day and Year. Press ✓ to store the setting.

**Time** Press ▲ or ▼ to select the current time in Hours, Minutes and Seconds. Press ✓ to store the setting.

**Interval** Press ▲ or ▼ to select the logging interval. Press ✓ to store the setting.

**Data Log** Stop, Start or Delete the log file. Press ▲ or ▼ to Delete and ✓ to delete the log file. Press ▲ or ▼ to Start and ✓ to start the logger.

**Note:** You MUST delete old log and start a new log AFTER having set changes to Log Site ID, Mode and/or Interval for those changes to be applied to the log file.

### RETRIEVE LOG FILE

Plug a USB Flash Memory Drive (one is included with the OCF 6.1) into the USB output port on the instrument. The instrument display will show the USB file download icon until the log file is transferred to the memory card and then display file download completed icon. The USB flash drive may be removed.

Download file names will appear in this format:

OCF \_ \_00A .LOG  
↑           ↑   ↑  
MODEL   TAG   DOWNLOAD

Tag is set according to the Log Site ID entered in the instrument Data Logging menu.

Download letter will be A for the first download from an instrument. B for the second, then C etc. At the letter Z a - character will appear indicating that the maximum number of downloads for that instrument are on the USB flash drive. Older files can be erased or moved from the flash memory drive or a new memory drive can be used.

### OPENING LOG FILES

Install Greyline Logger on your PC or laptop. An installer is included on the USB drive included with the OCF 6.1 or you can download from [www.pulsarmeasurement.com](http://www.pulsarmeasurement.com). Refer to the Help menu in the program for detailed instructions.

Select File/Open/Instrument Log (.log) to open the log file from your USB flash drive.

```

--Special Functions--
▶Language      English
Analog Out     4-20mA
Backlight      High
Reset Totalizer NO
Capture Par    NO
Restore Defaults NO
New Password   0000
    
```

**SPECIAL FUNCTIONS**

- Language**            Select English, Spanish or French
  - Analog Out**        Select 4-20mA or 0-5V mode for the analog output.
  - Backlight**        Select High, Medium or Low for continuous backlight.

                    Select Key Hi/Lo for high backlight (for 1 minute) after a keypress and then Lo backlight until a key is pressed again.

                    Select Key High, Med or Low for backlight after a keypress and then backlight off until a key is pressed again.
  - Reset Totalizer**    Select Yes to erase and restart the totalizer at zero. This only effects the main totalizer. The 365 day data remains unchanged.
  - Capture Par**        This function captures the programming parameters in the meter. Select Yes, wait for Done to appear, then insert a USB drive into the USB port to transfer the parameters.
  - Restore Defaults**    Select US to erase all user settings and return the instrument to factory default settings with US units. Select Metr to return the instrument to factory default settings with metric units
  - New Password**      Select any number from 0000 to 9999 and press ✓. Default setting of 0000 will allow direct access to the calibration menus. Setting of any password greater than 0000 will require the password to be entered to access the calibration menus.
- Press ✓ to return to Menu Selections.

```

--Simulation-----
▶ Test           Actual
Flow            250USG/m
4-20mAFlow     4.00
Relays 1 2 3 4 5 6
    
```

**SIMULATION**

Exercises the 4-20mA (0-5V) output, digital display and control relays.

**Test**                      Select **Maximum** and press ✓ to simulate maximum Flow, Range or Level and to output 20mA (5V) to the analog channel.

Select **Minimum** and press ✓ to simulate minimum Flow, Range or Level and to output 4mA (0V) to the analog channel.

To simulate an intermediate Flow, Range or Level set **Test** to **Actual** and then enter a value for the **Flow**, **Range** or **Level**. The analog output and control relays will respond to the simulated value.

```

--Tech's Menu-----
▶ Dist = Max     No
Barrier         No
Standpipe       No
Long Pulse     No
Gain            115
    
```

**TECH'S MENU**

**Dist = Max**              Choose YES to set the measured range as the Max Range. This is used when the level in the flume/weir/tank is at the zero level point, to quickly calibrate the Max Range so that a manual measurement does not need to be taken.

**Barrier**                      Will be set from the factory. NO when no intrinsic safety barriers are installed, and YES when barriers are installed.

**Standpipe**                  Will be set to NO from the factory. Only select YES after factory recommendation to do so. Reduces the frequency of pulses sent from the transducer, to reduce the potential negative impact of false echoes from inside a tank or standpipe.

**Long Pulse**                Will be set to NO from the factory. Only select YES after factory recommendation to do so.

**Gain**                        Displays a read-only value of the automatic gain level. Higher values indicate that the received echo is being amplified more. Values near the max of 255 indicate maximum amplification, and sources of echo attenuation should be investigated, such as wrong wire types spliced into the sensor cable, surface foam, vapors in the atmosphere, or a transducer not parallel to the fluid surface.

**SENSOR MOUNTING METHODS**

**Notes:**

1. Use the 3/4" NPT "Isolation Coupling" supplied and *hand tighten* only. Do not clamp sensor body or stem.
2. Locate the sensor 1 ft (30 cm) from the sidewall or obstruction for every 10 ft (3 m) depth.
3. Do not mount in direct sunlight.
4. Extend sensor cable up to 500 ft (150 m) with RG62AU coaxial only.

**FLANGE MOUNT**

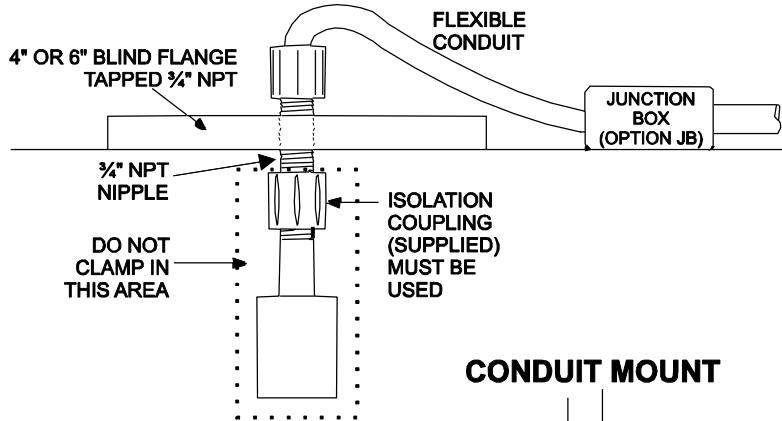

**CROSS BAR MOUNT**

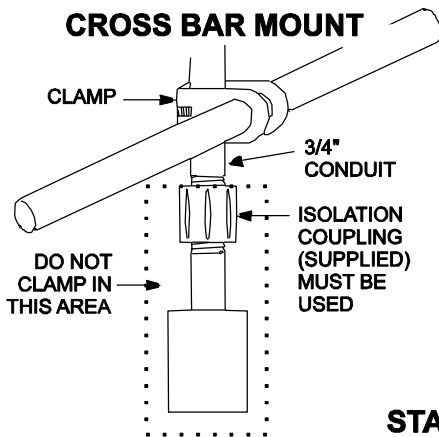

**CONDUIT MOUNT**

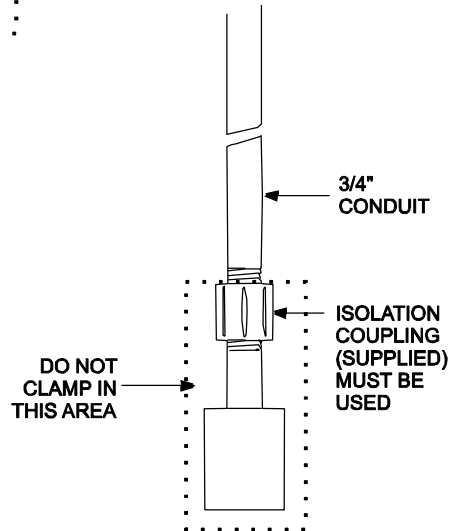

**STAND PIPE MOUNT**

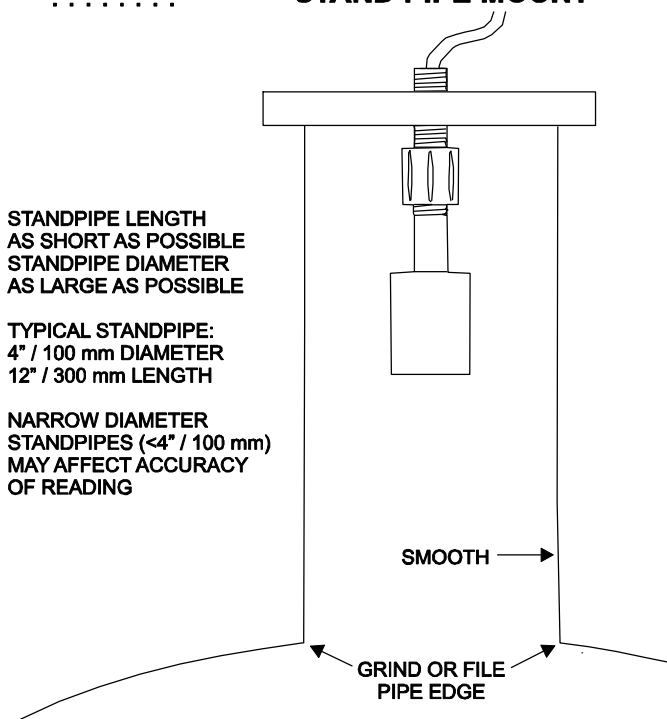

**ANGLE MOUNT**

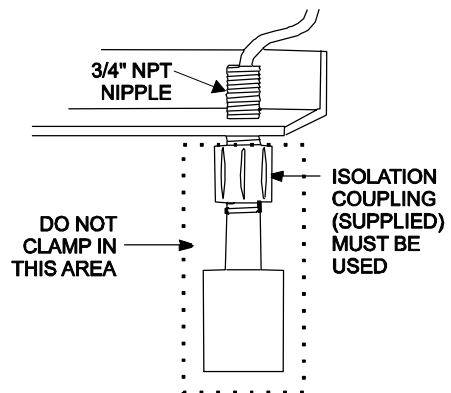

## SENSOR MOUNTING/LOCATION

### - Open Channel Flow Applications

Each sensor is equipped with a 3/4 inch isolation coupling which **MUST** be used in your installation. A threaded nipple or length of conduit may be used to position the sensor at the desired height. The sensor should be hand-tightened by turning the sensor stem only. **DO NOT** use a wrench and do not over tighten.

**IMPORTANT:** Follow the flume manufacturer's directions for sensor location. The sensor should be centered above the flume approach section and mounted 8"/203 mm (minimum) above the maximum liquid level (depending on sensor model).

The sensor should be protected from physical damage and the sensor cable should be routed in a separate metal conduit.

Because the sensor is equipped with a temperature sensor, it should be shielded from direct sunlight.

Use the PVC "isolation coupling" supplied with the sensor and hand-tighten the sensor/coupling assembly onto your mounting stand. Do not clamp directly to the sensor or to the isolation coupling.

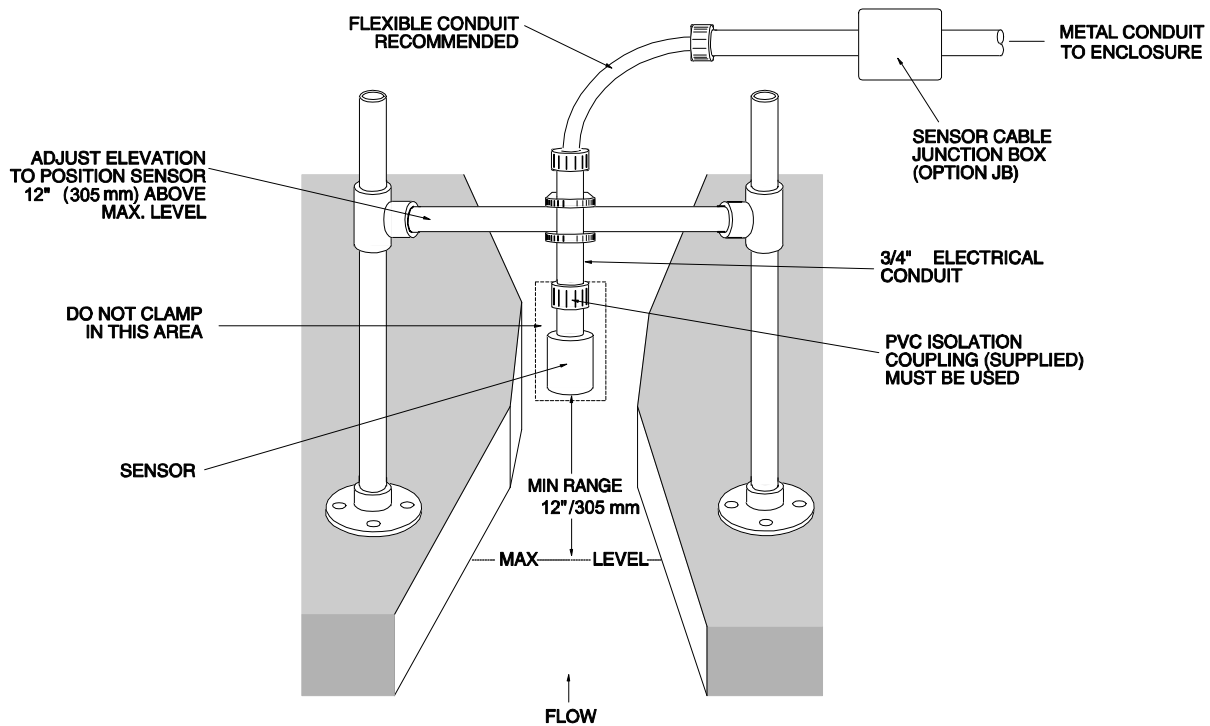

**TYPICAL SENSOR POSITIONING FOR FLUMES AND WEIRS**

Always refer to the flume or weir manufacturer’s instructions for correct measurement point upstream from the flume or weir. Location of the sensor is critical for accurate flow measurement.

If manufacturer’s instructions are not available, the following guidelines are generally accepted.

**1. PARSHALL FLUME:**

Position the sensor at 2/3 Approach as illustrated above. Sensor height must be 8" (203 mm) or more above the highest water level.

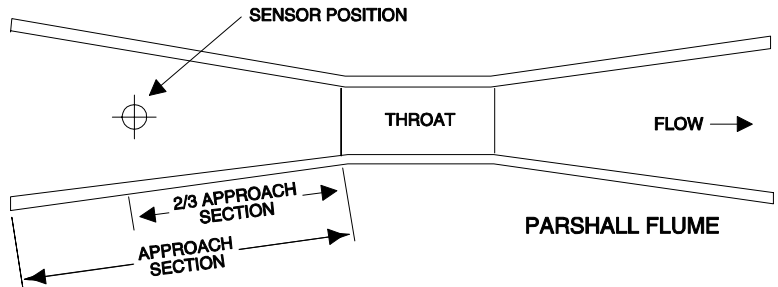

**2. PALMER BOWLUS FLUMES:**

Position the sensor at 1/2 the flume Diameter upstream from the throat of the flume. Sensor height must be 8" (203 mm) or more above the highest water level.

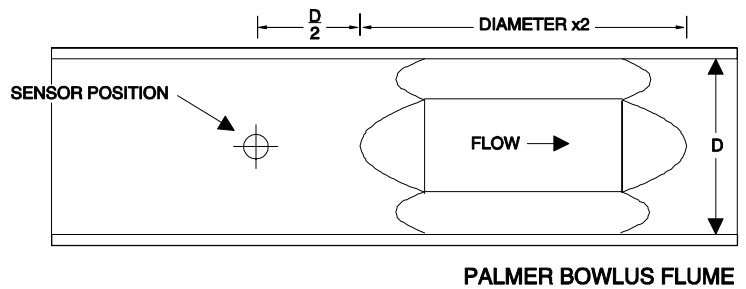

**3. V-NOTCH WEIRS**

Position the sensor at 3 x maximum Head upstream from the weir plate. Sensor height must be 8" (20.3 cm) or more above the highest water level.

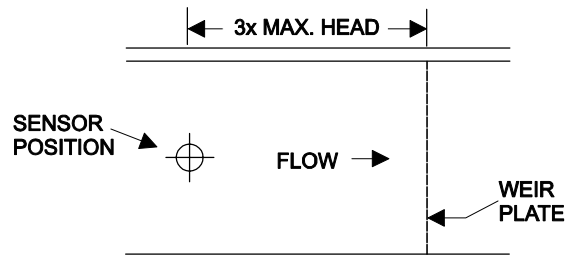

**STILLING WELLS**

Stilling wells are recommended to reduce the effects of turbulence as water flows through the flume or weir. The OCF 6.1 sensor is centered over the stilling well. Sensor height must be 8" (203 mm) or more above the highest water level. The well must be kept clean of sediment and deposits on the side walls.

## ZERO POSITIONING OF SENSOR - Open Channel Flow Applications

Locate the sensor at the position upstream from the throat of the flume or weir plate as recommended by the manufacturer. A technique for accurate sensor height adjustment is shown:

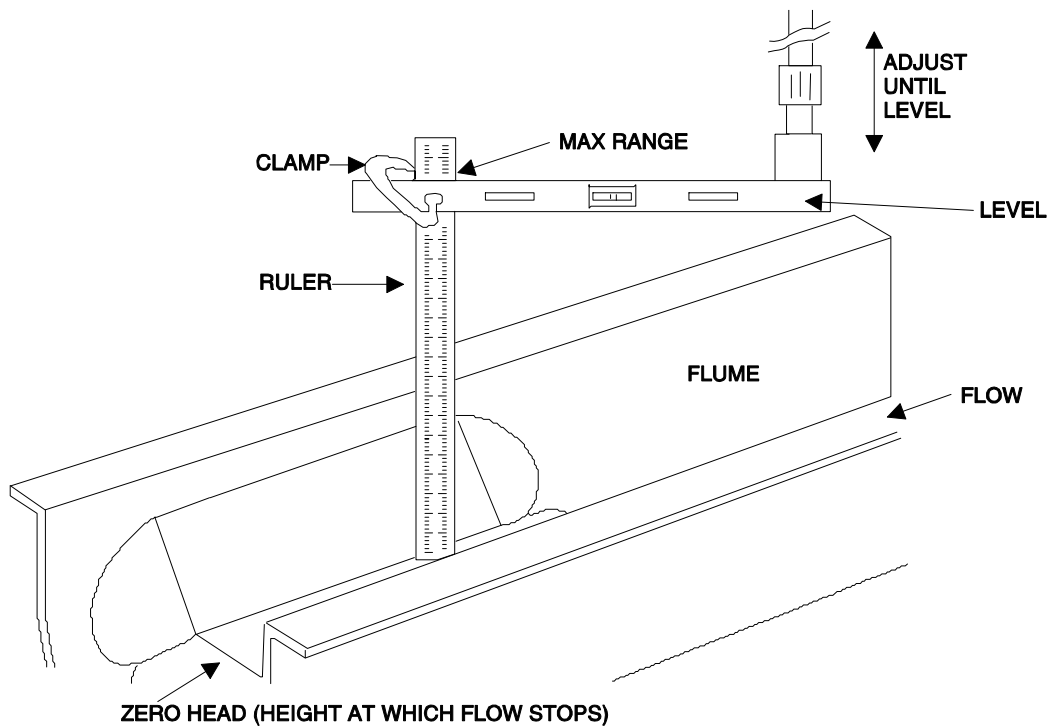

## ENCLOSURE INSTALLATION

Locate the enclosure within 20 ft (6 m) of the sensor (500 ft -150 m optional). The enclosure can be wall mounted with the four mounting screws (included) or panel mounted with Option PM Panel Mount kit from Pulsar Measurement.

Avoid mounting the enclosure in direct sunlight to protect the electronics from damage due to overheating and condensate. In high humidity atmospheres, or where temperatures fall below freezing, Option TH Enclosure Heater and Thermostat is recommended. Seal conduit entries to prevent moisture from entering enclosure.

### NEMA4X (IP66) WITH CLEAR COVER

1. Open hinged enclosure cover.
2. Insert #12 screws (supplied) through the four enclosure mounting holes to secure the enclosure to the wall or mounting stand.

Additional conduit holes can be cut in the bottom of the enclosure when required. Use a hole saw or Greenlee-type hole cutter to cut the required holes.

DO NOT make conduit/wiring entries into the top of the enclosure.

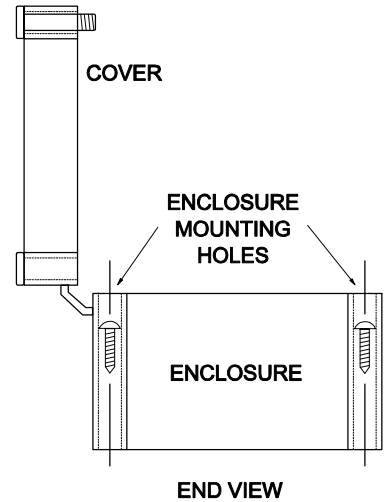

Note: This non-metallic enclosure does not automatically provide grounding between conduit connections. Grounding must be provided as part of the installation. Ground in accordance with the requirements of the National Electrical Code. System grounding is provided by connecting grounding wires from all conduit entries to the steel mounting plate or another point which provides continuity.

## CLEANING

Cleaning is not required as a part of normal maintenance.

**ERROR/WARNING MESSAGES**

ECHO LOSS	No valid echoes received within the <code>LOE TIME</code> setting. The OCF 6.1 will force the display and outputs to zero until a new echo is received.
- or -	Your choice of Units exceeds 9,999,999. Use <code>USMG/d</code> , <code>IMG/d</code> or <code>m3/d</code> so that Units will be 9,999,999 or less
ECHO TOO CLOSE	Indicates that the target is less than <code>Min Range</code> distance from the sensor (too close to the sensor).
SENSOR OPEN	Instrument has detected sensor connection/cable Open.
SENSOR SHORTED	Instrument has detected sensor connection/cable Shorted.

**FIELD TROUBLESHOOTING**

<u>SYMPTOMS</u>	<u>CHECK</u>
<b>Display - full scale</b>	A
<b>- zero</b>	B
<b>- erratic - random</b>	C
<b>- drifting up</b>	D
<b>- drifting down</b>	E
<b>ECHO LOSS prompt - flashing</b>	F
<b>Calibration Non-Linear</b>	H

<u>SYMPTOMS</u>	<u>FAULTS</u>	<u>SOLUTIONS</u>
<b>Unit "See's" Wrong Target Due To:</b>		
<b>A,F</b>	- sensor cover not removed	- remove protective cover after installation
<b>A,C,D,F</b>	- sensor not aimed correctly	
<b>A,D,F</b>	- dust/dirt buildup on sensor	- clean <i>carefully</i> (do not scratch sensor face)
		- lower Sensor
		- insulate sensor mounting location
<b>A,D,F</b>	- condensation on sensor	- increase <b>Min Range</b> (CALIBRATION menu) by 1-3" / 2.5-7.5 cm
		- wipe sensor face and body with Rain-X
	- sensor mounting stand pipe	
<b>A,D</b>	- too long / - too narrow	- lower Sensor below stand pipe intrusion
	- dirty / - gasket intruding	
<b>C,E,F</b>	- very turbulent flow in open channel	- increase <b>Damping</b> (CALIBRATION menu)
		- install stilling well on flume or weir
<b>C,E,F</b>	- very turbulent level in tank	- increase <b>Damping</b> (CALIBRATION menu)
		- change tank fill method

**FIELD TROUBLESHOOTING Cont.**

<u>SYMPTOMS</u>	<u>CHECK</u>
<b>Unit Picks-Up Interference Due To:</b>	
<b>A,C</b> - noise from high pressure fill	- install submerged fill pipe
<b>A,D</b> - sensor coupling over tightened	- hand tighten only (like a light bulb)
<b>A,D</b> - sensor coupling not used	- use coupling supplied
<b>C</b> - other ultrasonic unit in close proximity	- synchronize
<b>Electrical interference:</b>	
<b>C</b> - sensor cable connections reversed	
<b>C</b> - through sensor cable	- use properly <i>grounded</i> metal conduit
<b>C</b> - sensor cable extended and junction not insulated	- Use metal Junction Box
<b>C</b> - through enclosure	- use metal enclosure
<b>C</b> - through 4-20mA output cable	- use shielded twisted pair (shielded to AC ground) - use grounded metal conduit
<b>C</b> - wiring or installation close to variable speed drive or inverter	- follow V.S.D. manufacturer's instructions for Drive grounding, wiring and shielding
<b>Unit Receives No Return Echo Due To:</b>	
<b>C,F,E</b> - foam on liquid surface	- use stilling well (open channel flow)
<b>B</b> - target beyond Max Range	- recalibrate
<b>F</b> - sensor damaged	- remove sensor from mounting and aim at a flat, stable target to test
<b>F</b> - sensor misalignment	- check with a level

**FIELD TROUBLESHOOTING Cont.**

**SYMPTOMS**

**CHECK**

***Wiring Problems Due To Sensor Cable:***

<b>A,C,F,</b>	- open circuit	- check connections/continuity (8850 to 12700 ohms max./-30°C to +70°C)
<b>B,F</b>	- short circuit	- check connections/continuity (8850 ohms min.)
<b>F</b>	- too long (max 500 ft., 150 m)	
<b>C</b>	- bundled/run in conduit with power cable	
<b>C</b>	- sensor ground shorted to conduit/enclosure	- insulate
<b>A</b>	- extended with wrong type of wire	- use RG62A/U coaxial only
<b>C</b>	- close to high voltage/large motors	
<b>C</b>	- AC chassis/ground missing on instrument power connections	

***Non-Linearity Due To:***

<b>H</b>	- vapour	- dissipate fumes, Calibration in-situ
<b>H</b>	- zero not set accurately	- see "Zero Positioning of Sensor"
<b>H</b>	- wrong flume, or K&n selected (FLOW mode)	- select correct flume
	- temperature measurement inaccuracy	- install sensor sunscreen - mount sensor closer to flow

**PZxx Series Sensors****Troubleshooting**

Resistance measured (between the shield and center wire) across the coaxial cable ends by multimeter indicates ambient temperature.

**Resistance vs. Temperature**  
**Values are in Ohms**

<b>TEMP °C</b>	<b>+0</b>	<b>+1</b>	<b>+2</b>	<b>+3</b>	<b>+4</b>	<b>+5</b>	<b>+6</b>	<b>+7</b>	<b>+8</b>	<b>+9</b>
<b>0</b>	10000	10039	10078	10117	10156	10195	10234	10273	10312	10351
<b>10</b>	10390	10429	10468	10507	10546	10584	10623	10662	10701	10740
<b>20</b>	10779	10818	10857	10895	10934	10973	11012	11051	11089	11128
<b>30</b>	11167	11206	11244	11283	11322	11360	11399	11438	11476	11515
<b>40</b>	11554	11592	11631	11669	11708	11747	11785	11824	11862	11901
<b>50</b>	11939									

**Values are in Ohms**

<b>TEMP °F</b>	<b>+0</b>	<b>+1</b>	<b>+2</b>	<b>+3</b>	<b>+4</b>	<b>+5</b>	<b>+6</b>	<b>+7</b>	<b>+8</b>	<b>+9</b>
<b>30</b>			10000	10021	10043	10065	10086	10108	10130	10151
<b>40</b>	10173	10195	10216	10238	10260	10281	10303	10325	10346	10368
<b>50</b>	10390	10411	10433	10455	10476	10498	10520	10541	10563	10584
<b>60</b>	10606	10628	10649	10671	10692	10714	10736	10757	10779	10800
<b>70</b>	10822	10844	10865	10887	10908	10930	10951	10973	10995	11016
<b>80</b>	11038	11059	11081	11102	11124	11145	11167	11188	11210	11231
<b>90</b>	11253	11274	11296	11317	11339	11360	11382	11403	11425	11446
<b>100</b>	11468	11489	11511	11532	11554	11575	11596	11618	11639	11661
<b>110</b>	11682	11704	11725	11747	11768	11789	11811	11832	11854	11875
<b>120</b>	11896	11918	11939							

**APPLICATIONS HOTLINE**

For applications assistance, advice or information on any Pulsar Measurement Instrument contact your Sales Representative, write to Pulsar Measurement or phone the Applications Hotline below:

COUNTRY	TEL	FAX	E-MAIL	ADDRESS
<b>United States</b>	315-788-9500	315-764-0419	<a href="mailto:northamerica@pulsarmeasurement.com">northamerica@pulsarmeasurement.com</a>	11451 Belcher Road South Largo, FL 33773
<b>Canada</b>	613-938-8956	613-938-4857	<a href="mailto:northamerica@pulsarmeasurement.com">northamerica@pulsarmeasurement.com</a>	16456 Sixsmith Drive Long Sault, Ont. K0C 1P0
<b>UK</b>	+44 (0) 1684 891371	+44 (0) 1684 575985	<a href="mailto:europa@pulsarmeasurement.com">europa@pulsarmeasurement.com</a>	Cardinal Building Enigma Commercial Centre Sandy's Road, Malvern WR14 1JJ
<b>Asia</b>	N/A	N/A	<a href="mailto:asiapacific@pulsarmeasurement.com">asiapacific@pulsarmeasurement.com</a>	34-1A, Jalan 10A/KU5 Taman Aman Perdana 41050 Klang, Selangor, Malaysia
<b>Oceania</b>	+61 428 692 274	N/A	<a href="mailto:oceania@pulsarmeasurement.com">oceania@pulsarmeasurement.com</a>	N/A

**PRODUCT RETURN PROCEDURE**

Instruments may be returned to Pulsar Measurement for service or warranty repair.

**1** Obtain an RMA Number from Pulsar Measurement -

Before shipping a product to the factory please contact Pulsar Measurement by telephone, fax or email to obtain an RMA number (Returned Merchandise Authorization). This ensures fast service and correct billing or credit.

When you contact Pulsar Measurement please have the following information available:

1. Model number / Software Version
2. Serial number
3. Date of Purchase
4. Reason for return (description of fault or modification required)
5. Your name, company name, address and phone number

**2** Clean the Sensor/Product -

***Important: unclean products will not be serviced and will be returned to the sender at their expense.***

1. Rinse sensor and cable to remove debris.
2. If sensor has been exposed to sewage, immerse both sensor and cable in a solution of 1 part household bleach (Javex, Clorox etc.) to 20 parts water for 5 minutes. Important: do not immerse open end of sensor cable.
3. Dry with paper towels and pack sensor and cable in a sealed plastic bag.
4. Wipe the outside of the enclosure to remove dirt or deposits.
5. Return to Pulsar Measurement for service.

## LIMITED WARRANTY

---

Pulsar Measurement warrants, to the original purchaser, its products to be free from defects in material and workmanship for a period of two years from date of invoice. Pulsar Measurement will replace or repair, free of charge, any Pulsar product if it has been proven to be defective within the warranty period. This warranty does not cover any expenses incurred in the removal and re-installation of the product.

If a product manufactured by Pulsar should prove defective within the first year, return it freight prepaid to Pulsar Measurement along with a copy of your invoice.

This warranty does not cover damages due to improper installation or handling, acts of nature, or unauthorized service. Modifications to or tampering with any part shall void this warranty. This warranty does not cover any equipment used in connection with the product or consequential damages due to a defect in the product.

All implied warranties are limited to the duration of this warranty. This is the complete warranty by Pulsar Measurement and no other warranty is valid against Pulsar Measurement. Some states do not allow limitations on how long an implied warranty lasts or limitation of incidental or consequential damages, so the above limitations or exclusions may not apply to you.

This warranty gives you specific legal rights, and you may also have other rights which vary from state to state.

Pulsar Measurement

**APPENDIX A - OPTIONS**

**EXTRA SENSOR CABLE - OPTION XC**

Each level instrument includes 25 ft. (7.6 m) RG62AU coaxial cable. Additional RG62AU coaxial cable and Cable Junction Box (Option JB2X) may be installed to extend cable up to 500 ft (152m) as required during installation. No adjustment is required when the sensor cable is extended or shortened. Use only RG62AU (or RG62U) coaxial cable which is available from Pulsar Measurement or your local distributor. Nominal impedance of RG62AU cable is 93 ohms.

Extended sensor cable maybe installed in metal or plastic conduit. Recommended installation with a junction box is illustrated below:

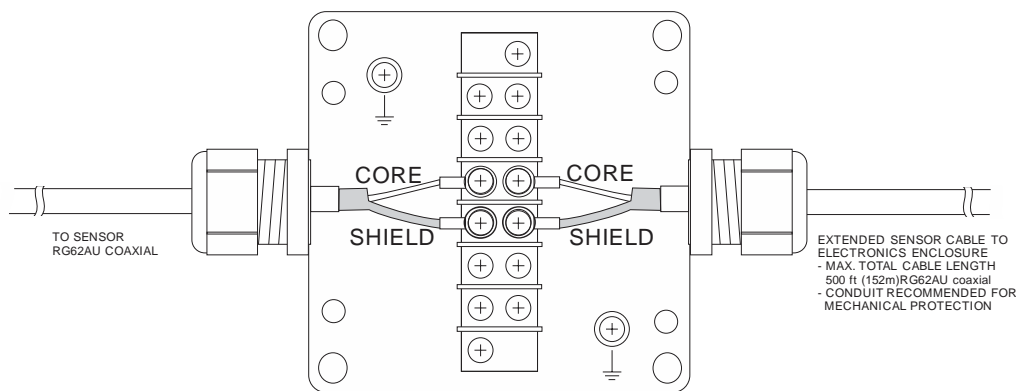

**JUNCTION BOX - OPTION JB2X**

NEMA4X (IP66) polycarbonate Junction Box with terminal strips is available from Pulsar Measurement. Includes compression fittings for watertight coaxial cable entries.

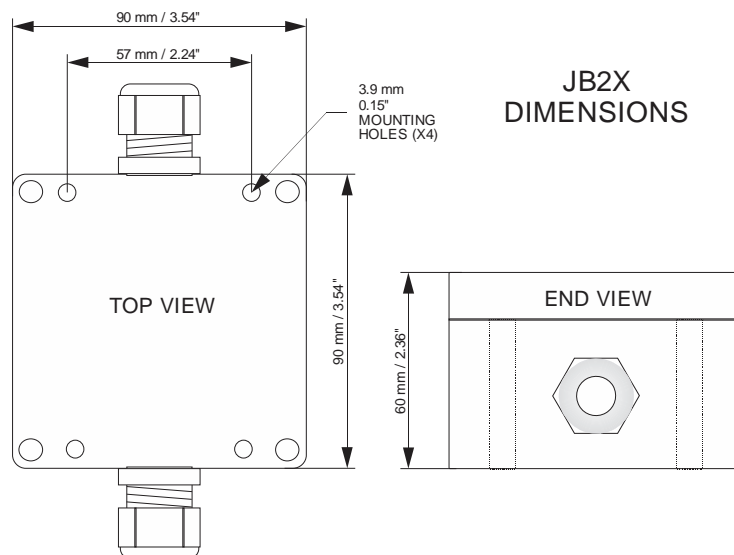

**EXTENDED SENSOR CABLE INSTALLATION IN MANHOLE**

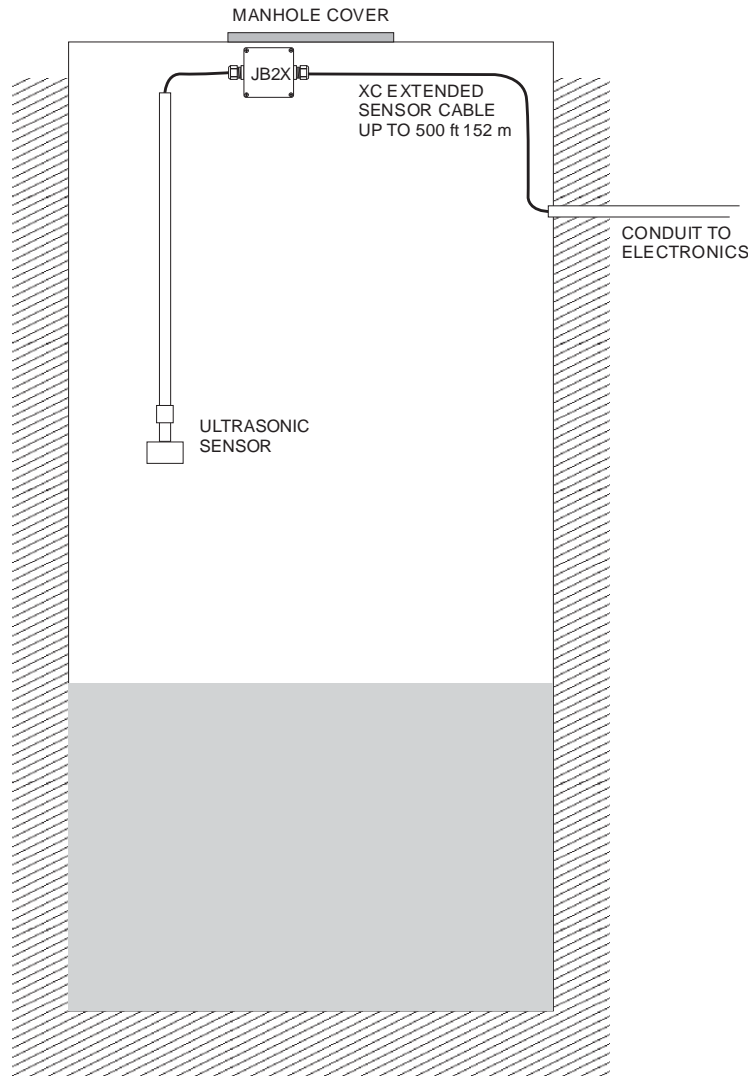

***SENSOR INTRINSIC SAFETY  
(OPTION ISB)***

When connected through Intrinsic Safety Barriers, PZ\*\* Series sensors are certified for installation in a hazardous location rated:

Class I, Groups C,D

Class II, Groups E,F,G

Class III

The Intrinsic Safety Barrier may be ordered with the instrument and is supplied mounted in the electronics enclosure. Replacement barrier fuses (Part No. ISB- 011239) may be purchased separately. The instrument enclosure containing the ISB Intrinsic Safety Barrier must be installed in a non-hazardous location.

### GN3SPEC-ISB-11

The intrinsic safety barrier assemblies installed in the OCF 6.1 limit the voltage and current supplied to the transducers to the values listed under 'Barrier Specifications'. To safely install a Greyline transducer certified for use in hazardous locations you must refer to the installation drawings/specifications of the certified transducer.

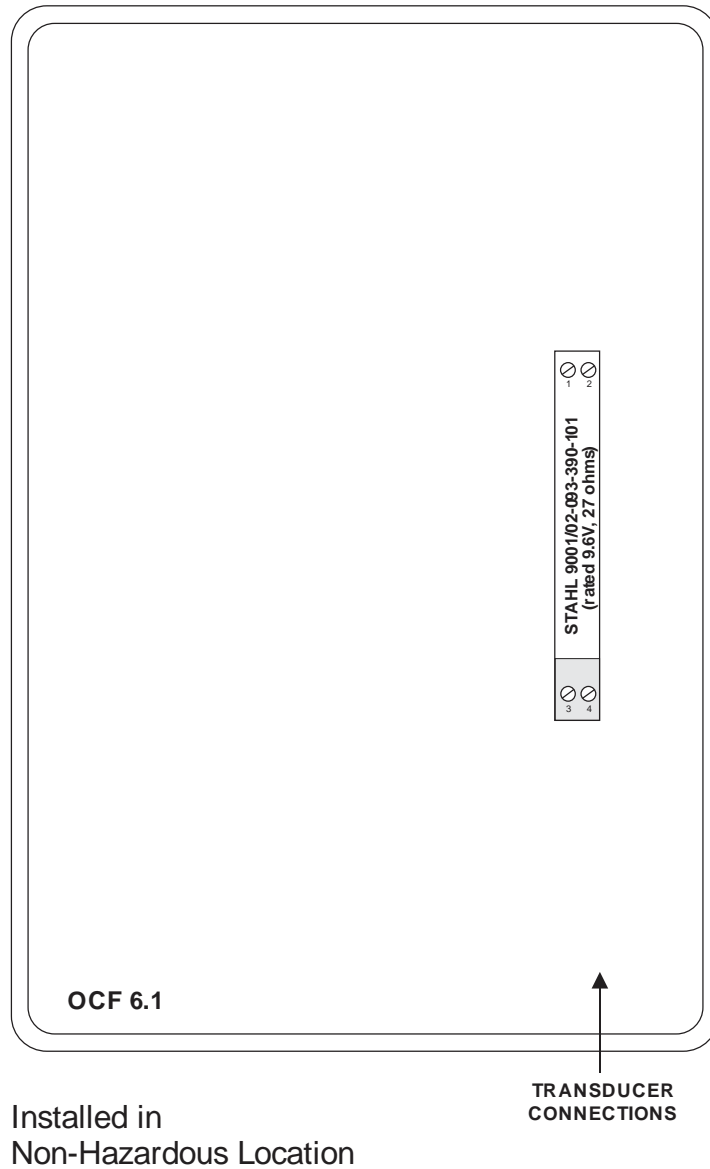

### BARRIER SPECIFICATIONS

STAHL BARRIER	System Parameters	Entity Parameters					
		$U_m$	$V_{0c}$	$I_{sc}$	$P_0$	$C_a$	$L_a$
9001/02-093-390-101	9.6V, 27 ohms	250V	9.3V	390mA	906.8mW	4.1 $\mu$ F	0.16mH

**MODBUS® COMMUNICATION**

MODBUS® serial interface connections are made at the RS485 card's terminal block if your OCF 6.1 was ordered with this card, or if one was added after installation. Card location:

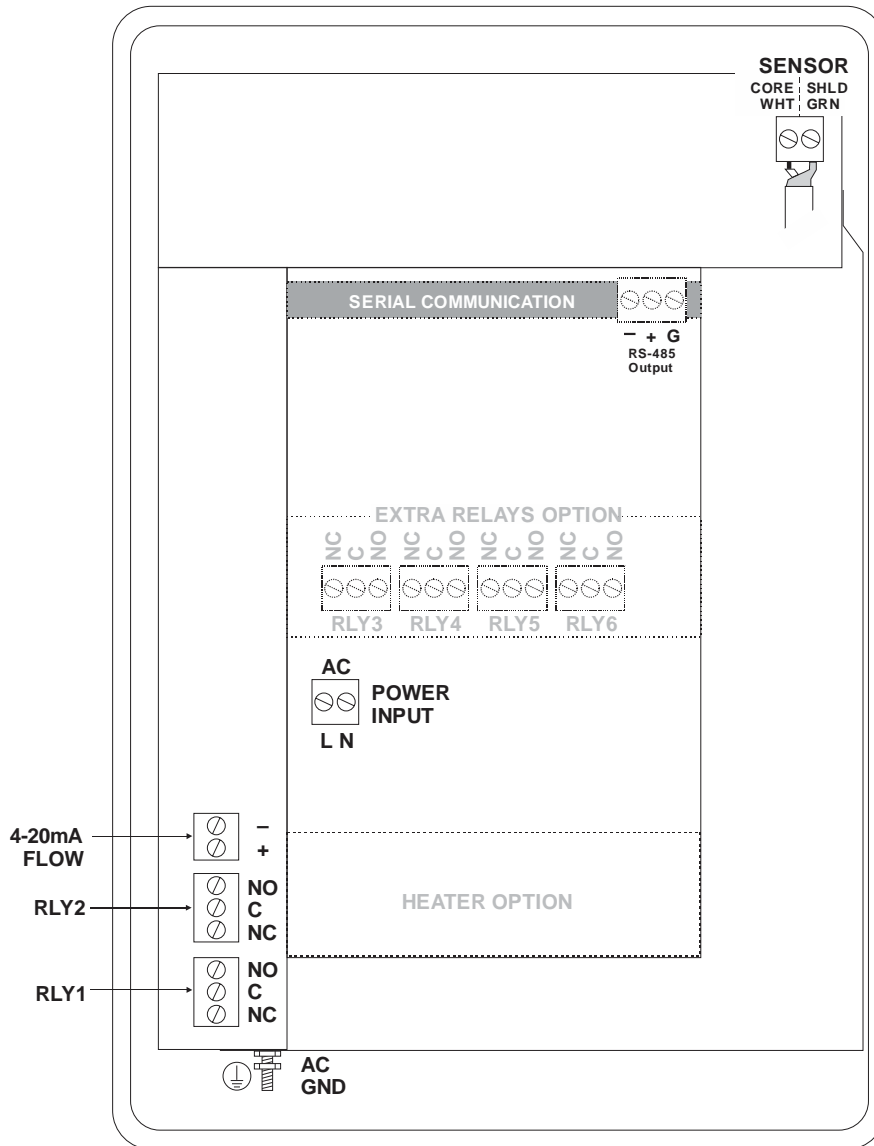

Transceiver: 2-wire, half-duplex  
 MODBUS Address (MAC address) range: 1-255 (Default: 001)  
 BAUD rates: 4800, 9600, 19200, 38400, 57600, 76800 or 115200 (Default: 9600)  
 Data Bits: 8  
 Parity: None, Even, Odd (Default: Even)  
 Stop Bits: 1, 2 (Default: 1)  
 Termination: 120 Ohms or none (Default: None)  
 Jumper JP1 position 1 & 2 = OFF (No term)  
 Jumper JP1 position 2 & 3 = ON (Term)  
 Biasing: None  
 Flow Control: None

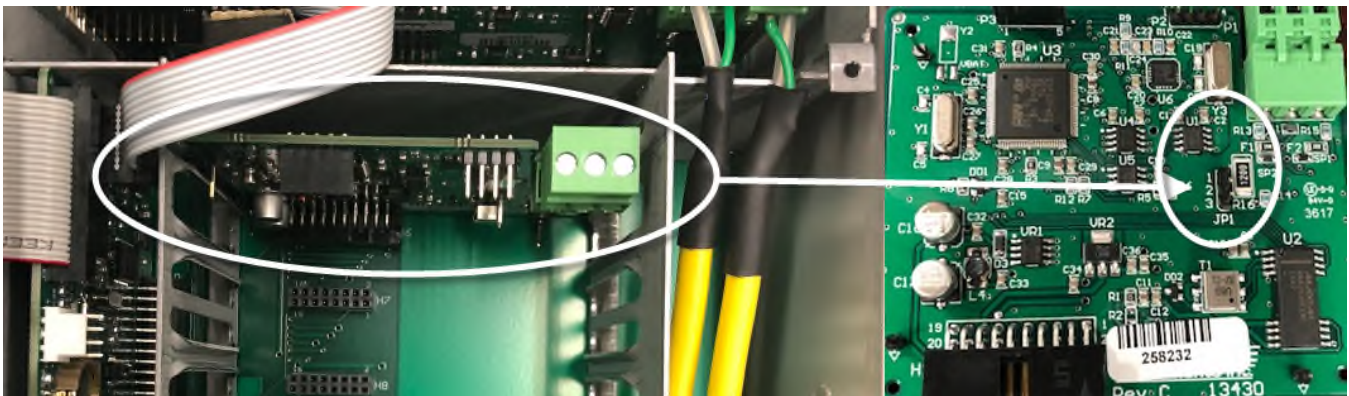

Termination Jumper Position

<b>Function Codes Supported:</b>
01 – Read Coil(s)
02 – Read Discreet Input(s)
04 – Read Input Register(s)
05 – Write Single Coil
06 – Write Single Register
15 – Write Multiple Coils
16 – Write Multiple Registers
17 – Report Slave ID

**MODBUS® MEMORY MAP**

Register Address	Description	Register Type	Data Range	Over Range	Read/Write	Comments
<b>1</b>	Reset Volume Total	Coil	NA	NA	Read/Write	Turn coil ON (1) to reset total on OCF 6.1. Turn coil to OFF (0) once reset is complete.

Register Address	Description	Register Type	Data Range	Over Range	Read/Write	Comments
<b>10001</b>	Pulse Output 1 Status	Discreet Input	NA	NA	Read	(0) indicates pulse output is OFF or inactive. (1) indicates pulse output is ON or active.
<b>10002</b>	Pulse Output 2 Status	Discreet Input	NA	NA	Read	(0) indicates pulse output is OFF or inactive. (1) indicates pulse output is ON or active.

Register Address	Description	Register Type	Format Type	Comments
<b>30001</b>	Flow Velocity - ft/s	Input Register	Floating Point Register (1 of 2)	
<b>30002</b>	Flow Velocity - ft/s	Input Register	Floating Point Register (2 of 2)	
<b>30003</b>	Flow Velocity - m/s	Input Register	Floating Point Register (1 of 2)	
<b>30004</b>	Flow Velocity - m/s	Input Register	Floating Point Register (2 of 2)	
<b>30101</b>	Flow Rate - GPM (USG/min)	Input Register	Floating Point Register (1 of 2)	
<b>30102</b>	Flow Rate - GPM (USG/min)	Input Register	Floating Point Register (2 of 2)	
<b>30103</b>	Flow Rate - L/sec	Input Register	Floating Point Register (1 of 2)	
<b>30104</b>	Flow Rate - L/ssec	Input Register	Floating Point Register (2 of 2)	
<b>30105</b>	Flow Rate - ft <sup>3</sup> /min	Input Register	Floating Point Register (1 of 2)	
<b>30106</b>	Flow Rate - ft <sup>3</sup> /min	Input Register	Floating Point Register (2 of 2)	
<b>30107</b>	Flow Rate - m <sup>3</sup> /hr	Input Register	Floating Point Register (1 of 2)	
<b>30108</b>	Flow Rate - m <sup>3</sup> /hr	Input Register	Floating Point Register (2 of 2)	
<b>30109</b>	Flow Rate - USG/sec	Input Register	Floating Point Register (1 of 2)	
<b>30110</b>	Flow Rate - USG/sec	Input Register	Floating Point Register (2 of 2)	
<b>30111</b>	Flow Rate - USG/hr	Input Register	Floating Point Register (1 of 2)	
<b>30112</b>	Flow Rate - USG/hr	Input Register	Floating Point Register (2 of 2)	
<b>30113</b>	Flow Rate - USG/day	Input Register	Floating Point Register (1 of 2)	

Register Address	Description	Register Type	Format Type	Comments
30114	Flow Rate - USG/day	Input Register	Floating Point Register (2 of 2)	
30115	Flow Rate - ft <sup>3</sup> /s	Input Register	Floating Point Register (1 of 2)	
30116	Flow Rate - ft <sup>3</sup> /s	Input Register	Floating Point Register (2 of 2)	
30117	Flow Rate - ft <sup>3</sup> /hr	Input Register	Floating Point Register (1 of 2)	
30118	Flow Rate - ft <sup>3</sup> /hr	Input Register	Floating Point Register (2 of 2)	
30119	Flow Rate - ft <sup>3</sup> /day	Input Register	Floating Point Register (1 of 2)	
30120	Flow Rate - ft <sup>3</sup> /day	Input Register	Floating Point Register (2 of 2)	
30121	Flow Rate - USMG/sec	Input Register	Floating Point Register (1 of 2)	USMG = US Million Gallons
30122	Flow Rate - USMG/sec	Input Register	Floating Point Register (2 of 2)	USMG = US Million Gallons
30123	Flow Rate - USMG/min	Input Register	Floating Point Register (1 of 2)	USMG = US Million Gallons
30124	Flow Rate - USMG/min	Input Register	Floating Point Register (2 of 2)	USMG = US Million Gallons
30125	Flow Rate - USMG/hr	Input Register	Floating Point Register (1 of 2)	USMG = US Million Gallons
30126	Flow Rate - USMG/hr	Input Register	Floating Point Register (2 of 2)	USMG = US Million Gallons
30127	Flow Rate - USMG/day	Input Register	Floating Point Register (1 of 2)	USMG = US Million Gallons
30128	Flow Rate - USMG/day	Input Register	Floating Point Register (2 of 2)	USMG = US Million Gallons
30129	Flow Rate - L/min	Input Register	Floating Point Register (1 of 2)	
30130	Flow Rate - L/min	Input Register	Floating Point Register (2 of 2)	
30131	Flow Rate - L/hr	Input Register	Floating Point Register (1 of 2)	
30132	Flow Rate - L/hr	Input Register	Floating Point Register (2 of 2)	
30133	Flow Rate - L/day	Input Register	Floating Point Register (1 of 2)	
30134	Flow Rate - L/day	Input Register	Floating Point Register (2 of 2)	
30135	Flow Rate - m <sup>3</sup> /sec	Input Register	Floating Point Register (1 of 2)	
30136	Flow Rate - m <sup>3</sup> /sec	Input Register	Floating Point Register (2 of 2)	
30137	Flow Rate - m <sup>3</sup> /min	Input Register	Floating Point Register (1 of 2)	
30138	Flow Rate - m <sup>3</sup> /min	Input Register	Floating Point Register (2 of 2)	

Register Address	Description	Register Type	Format Type	Comments
30139	Flow Rate - m <sup>3</sup> /day	Input Register	Floating Point Register (1 of 2)	
30140	Flow Rate - m <sup>3</sup> /day	Input Register	Floating Point Register (2 of 2)	
30141	Flow Rate - IG/sec	Input Register	Floating Point Register (1 of 2)	IG = Imperial Gallons
30142	Flow Rate - IG/sec	Input Register	Floating Point Register (2 of 2)	IG = Imperial Gallons
30143	Flow Rate - IG/min	Input Register	Floating Point Register (1 of 2)	IG = Imperial Gallons
30144	Flow Rate - IG/min	Input Register	Floating Point Register (2 of 2)	IG = Imperial Gallons
30145	Flow Rate - IG/hr	Input Register	Floating Point Register (1 of 2)	IG = Imperial Gallons
30146	Flow Rate - IG/hr	Input Register	Floating Point Register (2 of 2)	IG = Imperial Gallons
30147	Flow Rate - IG/day	Input Register	Floating Point Register (1 of 2)	IG = Imperial Gallons
30148	Flow Rate - IG/day	Input Register	Floating Point Register (2 of 2)	IG = Imperial Gallons
30149	Flow Rate - IMG/sec	Input Register	Floating Point Register (1 of 2)	IMG = Imperial Million Gallons
30150	Flow Rate - IMG/sec	Input Register	Floating Point Register (2 of 2)	IMG = Imperial Million Gallons
30151	Flow Rate - IMG/min	Input Register	Floating Point Register (1 of 2)	IMG = Imperial Million Gallons
30152	Flow Rate - IMG/min	Input Register	Floating Point Register (2 of 2)	IMG = Imperial Million Gallons
30153	Flow Rate - IMG/hr	Input Register	Floating Point Register (1 of 2)	IMG = Imperial Million Gallons
30154	Flow Rate - IMG/hr	Input Register	Floating Point Register (2 of 2)	IMG = Imperial Million Gallons
30155	Flow Rate - IMG/day	Input Register	Floating Point Register (1 of 2)	IMG = Imperial Million Gallons
30156	Flow Rate - IMG/day	Input Register	Floating Point Register (2 of 2)	IMG = Imperial Million Gallons
30157	Flow Rate - bbl/sec	Input Register	Floating Point Register (1 of 2)	bbl = US Oil Barrel = 42 Gallons
30158	Flow Rate - bbl/sec	Input Register	Floating Point Register (2 of 2)	bbl = US Oil Barrel = 42 Gallons
30159	Flow Rate - bbl/min	Input Register	Floating Point Register (1 of 2)	bbl = US Oil Barrel = 42 Gallons
30160	Flow Rate - bbl/min	Input Register	Floating Point Register (2 of 2)	bbl = US Oil Barrel = 42 Gallons
30161	Flow Rate - bbl/hr	Input Register	Floating Point Register (1 of 2)	bbl = US Oil Barrel = 42 Gallons
30162	Flow Rate - bbl/hr	Input Register	Floating Point Register (2 of 2)	bbl = US Oil Barrel = 42 Gallons
30163	Flow Rate - bbl/day	Input Register	Floating Point Register (1 of 2)	bbl = US Oil Barrel = 42 Gallons

Register Address	Description	Register Type	Format Type	Comments
30164	Flow Rate - bbl/day	Input Register	Floating Point Register (2 of 2)	bbl = US Oil Barrel = 42 Gallons
30165	Previous day Average Flow Rate - GPM (USG/min)	Input Register	Floating Point Register (1 of 2)	
30166	Previous day Average Flow Rate - GPM (USG/min)	Input Register	Floating Point Register (2 of 2)	
30167	Previous day Average Flow Rate - L/sec	Input Register	Floating Point Register (1 of 2)	
30168	Previous day Average Flow Rate - L/ssec	Input Register	Floating Point Register (2 of 2)	
30169	Previous day Average Flow Rate - ft3/min	Input Register	Floating Point Register (1 of 2)	
30170	Previous day Average Flow Rate - ft3/min	Input Register	Floating Point Register (2 of 2)	
30171	Previous day Average Flow Rate - m3/hr	Input Register	Floating Point Register (1 of 2)	
30172	Previous day Average Flow Rate - m3/hr	Input Register	Floating Point Register (2 of 2)	
30173	Previous day Average Flow Rate - USG/sec	Input Register	Floating Point Register (1 of 2)	
30174	Previous day Average Flow Rate - USG/sec	Input Register	Floating Point Register (2 of 2)	
30175	Previous day Average Flow Rate - USG/hr	Input Register	Floating Point Register (1 of 2)	
30176	Previous day Average Flow Rate - USG/hr	Input Register	Floating Point Register (2 of 2)	
30177	Previous day Average Flow Rate - USG/day	Input Register	Floating Point Register (1 of 2)	
30178	Previous day Average Flow Rate - USG/day	Input Register	Floating Point Register (2 of 2)	
30179	Previous day Average Flow Rate - ft3/s	Input Register	Floating Point Register (1 of 2)	
30180	Previous day Average Flow Rate - ft3/s	Input Register	Floating Point Register (2 of 2)	
30181	Previous day Average Flow Rate - ft3/hr	Input Register	Floating Point Register (1 of 2)	
30182	Previous day Average Flow Rate - ft3/hr	Input Register	Floating Point Register (2 of 2)	
30183	Previous day Average Flow Rate - ft3/day	Input Register	Floating Point Register (1 of 2)	
30184	Previous day Average Flow Rate - ft3/day	Input Register	Floating Point Register (2 of 2)	
30185	Previous day Average Flow Rate - USMG/sec	Input Register	Floating Point Register (1 of 2)	USMG = US Million Gallons
30186	Previous day Average Flow Rate - USMG/sec	Input Register	Floating Point Register (2 of 2)	USMG = US Million Gallons

Register Address	Description	Register Type	Format Type	Comments
30187	Previous day Average Flow Rate - USMG/min	Input Register	Floating Point Register (1 of 2)	USMG = US Million Gallons
30188	Previous day Average Flow Rate - USMG/min	Input Register	Floating Point Register (2 of 2)	USMG = US Million Gallons
30189	Previous day Average Flow Rate - USMG/hr	Input Register	Floating Point Register (1 of 2)	USMG = US Million Gallons
30190	Previous day Average Flow Rate - USMG/hr	Input Register	Floating Point Register (2 of 2)	USMG = US Million Gallons
30191	Previous day Average Flow Rate - USMG/day	Input Register	Floating Point Register (1 of 2)	USMG = US Million Gallons
30192	Previous day Average Flow Rate - USMG/day	Input Register	Floating Point Register (2 of 2)	USMG = US Million Gallons
30193	Previous day Average Flow Rate - L/min	Input Register	Floating Point Register (1 of 2)	
30194	Previous day Average Flow Rate - L/min	Input Register	Floating Point Register (2 of 2)	
30195	Previous day Average Flow Rate - L/hr	Input Register	Floating Point Register (1 of 2)	
30196	Previous day Average Flow Rate - L/hr	Input Register	Floating Point Register (2 of 2)	
30197	Previous day Average Flow Rate - L/day	Input Register	Floating Point Register (1 of 2)	
30198	Previous day Average Flow Rate - L/day	Input Register	Floating Point Register (2 of 2)	
30199	Previous day Average Flow Rate - m3/sec	Input Register	Floating Point Register (1 of 2)	
30200	Previous day Average Flow Rate - m3/sec	Input Register	Floating Point Register (2 of 2)	
30201	Previous day Average Flow Rate - m3/min	Input Register	Floating Point Register (1 of 2)	
30202	Previous day Average Flow Rate - m3/min	Input Register	Floating Point Register (2 of 2)	
30203	Previous day Average Flow Rate - m3/day	Input Register	Floating Point Register (1 of 2)	
30204	Previous day Average Flow Rate - m3/day	Input Register	Floating Point Register (2 of 2)	
30205	Previous day Average Flow Rate - IG/sec	Input Register	Floating Point Register (1 of 2)	IG = Imperial Gallons
30206	Previous day Average Flow Rate - IG/sec	Input Register	Floating Point Register (2 of 2)	IG = Imperial Gallons
30207	Previous day Average Flow Rate - IG/min	Input Register	Floating Point Register (1 of 2)	IG = Imperial Gallons
30208	Previous day Average Flow Rate - IG/min	Input Register	Floating Point Register (2 of 2)	IG = Imperial Gallons
30209	Previous day Average Flow Rate - IG/hr	Input Register	Floating Point Register (1 of 2)	IG = Imperial Gallons
30210	Previous day Average Flow Rate - IG/hr	Input Register	Floating Point Register (2 of 2)	IG = Imperial Gallons

Register Address	Description	Register Type	Format Type	Comments
30211	Previous day Average Flow Rate - IG/day	Input Register	Floating Point Register (1 of 2)	IG = Imperial Gallons
30212	Previous day Average Flow Rate - IG/day	Input Register	Floating Point Register (2 of 2)	IG = Imperial Gallons
30213	Previous day Average Flow Rate - IMG/sec	Input Register	Floating Point Register (1 of 2)	IMG = Imperial Million Gallons
30214	Previous day Average Flow Rate - IMG/sec	Input Register	Floating Point Register (2 of 2)	IMG = Imperial Million Gallons
30215	Previous day Average Flow Rate - IMG/min	Input Register	Floating Point Register (1 of 2)	IMG = Imperial Million Gallons
30216	Previous day Average Flow Rate - IMG/min	Input Register	Floating Point Register (2 of 2)	IMG = Imperial Million Gallons
30217	Previous day Average Flow Rate - IMG/hr	Input Register	Floating Point Register (1 of 2)	IMG = Imperial Million Gallons
30218	Previous day Average Flow Rate - IMG/hr	Input Register	Floating Point Register (2 of 2)	IMG = Imperial Million Gallons
30219	Previous day Average Flow Rate - IMG/day	Input Register	Floating Point Register (1 of 2)	IMG = Imperial Million Gallons
30220	Previous day Average Flow Rate - IMG/day	Input Register	Floating Point Register (2 of 2)	IMG = Imperial Million Gallons
30221	Previous day Average Flow Rate - bbl/sec	Input Register	Floating Point Register (1 of 2)	bbl = US Oil Barrel = 42 Gallons
30222	Previous day Average Flow Rate - bbl/sec	Input Register	Floating Point Register (2 of 2)	bbl = US Oil Barrel = 42 Gallons
30223	Previous day Average Flow Rate - bbl/min	Input Register	Floating Point Register (1 of 2)	bbl = US Oil Barrel = 42 Gallons
30224	Previous day Average Flow Rate - bbl/min	Input Register	Floating Point Register (2 of 2)	bbl = US Oil Barrel = 42 Gallons
30225	Previous day Average Flow Rate - bbl/hr	Input Register	Floating Point Register (1 of 2)	bbl = US Oil Barrel = 42 Gallons
30226	Previous day Average Flow Rate - bbl/hr	Input Register	Floating Point Register (2 of 2)	bbl = US Oil Barrel = 42 Gallons
30227	Previous day Average Flow Rate - bbl/day	Input Register	Floating Point Register (1 of 2)	bbl = US Oil Barrel = 42 Gallons
30228	Previous day Average Flow Rate - bbl/day	Input Register	Floating Point Register (2 of 2)	bbl = US Oil Barrel = 42 Gallons
30301	Volume Total - Gallons	Input Register	Floating Point Register (1 of 2)	
30302	Volume Total - Gallons	Input Register	Floating Point Register (2 of 2)	
30303	Volume Total - Liters	Input Register	Floating Point Register (1 of 2)	
30304	Volume Total - Liters	Input Register	Floating Point Register (2 of 2)	
30305	Volume Total - ft <sup>3</sup>	Input Register	Floating Point Register (1 of 2)	
30306	Volume Total - ft <sup>3</sup>	Input Register	Floating Point Register (2 of 2)	

Register Address	Description	Register Type	Format Type	Comments
30307	Volume Total - m <sup>3</sup>	Input Register	Floating Point Register (1 of 2)	
30308	Volume Total - m <sup>3</sup>	Input Register	Floating Point Register (2 of 2)	
30309	Volume Total - USMG	Input Register	Floating Point Register (1 of 2)	USMG = US Million Gallons
30310	Volume Total - USMG	Input Register	Floating Point Register (2 of 2)	USMG = US Million Gallons
30311	Volume Total - IG	Input Register	Floating Point Register (1 of 2)	IG = Imperial Gallons
30312	Volume Total - IG	Input Register	Floating Point Register (2 of 2)	IG = Imperial Gallons
30313	Volume Total - IMG	Input Register	Floating Point Register (1 of 2)	IMG = Imperial Million Gallons
30314	Volume Total - IMG	Input Register	Floating Point Register (2 of 2)	IMG = Imperial Million Gallons
30315	Volume Total - bbl	Input Register	Floating Point Register (1 of 2)	bbl = US Oil Barrel = 42 Gallons
30316	Volume Total - bbl	Input Register	Floating Point Register (2 of 2)	bbl = US Oil Barrel = 42 Gallons
30317	Previous day Volume Total - Gallons	Input Register	Floating Point Register (1 of 2)	
30318	Previous day Volume Total - Gallons	Input Register	Floating Point Register (2 of 2)	
30319	Previous day Volume Total - Liters	Input Register	Floating Point Register (1 of 2)	
30320	Previous day Volume Total - Liters	Input Register	Floating Point Register (2 of 2)	
30321	Previous day Volume Total - ft <sup>3</sup>	Input Register	Floating Point Register (1 of 2)	
30322	Previous day Volume Total - ft <sup>3</sup>	Input Register	Floating Point Register (2 of 2)	
30323	Previous day Volume Total - m <sup>3</sup>	Input Register	Floating Point Register (1 of 2)	
30324	Previous day Volume Total - m <sup>3</sup>	Input Register	Floating Point Register (2 of 2)	
30325	Previous day Volume Total - USMG	Input Register	Floating Point Register (1 of 2)	USMG = US Million Gallons
30326	Previous day Volume Total - USMG	Input Register	Floating Point Register (2 of 2)	USMG = US Million Gallons
30327	Previous day Volume Total - IG	Input Register	Floating Point Register (1 of 2)	IG = Imperial Gallons
30328	Previous day Volume Total - IG	Input Register	Floating Point Register (2 of 2)	IG = Imperial Gallons
30329	Previous day Volume Total - IMG	Input Register	Floating Point Register (1 of 2)	IMG = Imperial Million Gallons
30330	Previous day Volume Total - IMG	Input Register	Floating Point Register (2 of 2)	IMG = Imperial Million Gallons

Register Address	Description	Register Type	Format Type	Comments
30331	Previous day Volume Total - bbl	Input Register	Floating Point Register (1 of 2)	bbl = US Oil Barrel = 42 Gallons
30332	Previous day Volume Total - bbl	Input Register	Floating Point Register (2 of 2)	bbl = US Oil Barrel = 42 Gallons
30501	Sensor Range - inches	Input Register	Floating Point Register (1 of 2)	Only used when through-air sensor is installed.
30502	Sensor Range - inches	Input Register	Floating Point Register (2 of 2)	Only used when through-air sensor is installed.
30503	Sensor Range - feet	Input Register	Floating Point Register (1 of 2)	Only used when through-air sensor is installed.
30504	Sensor Range - feet	Input Register	Floating Point Register (2 of 2)	Only used when through-air sensor is installed.
30505	Sensor Range - mm	Input Register	Floating Point Register (1 of 2)	Only used when through-air sensor is installed.
30506	Sensor Range - mm	Input Register	Floating Point Register (2 of 2)	Only used when through-air sensor is installed.
30507	Sensor Range - meters	Input Register	Floating Point Register (1 of 2)	Only used when through-air sensor is installed.
30508	Sensor Range - meters	Input Register	Floating Point Register (2 of 2)	Only used when through-air sensor is installed.
30525	Sensor Level - inches	Input Register	Floating Point Register (1 of 2)	
30526	Sensor Level - inches	Input Register	Floating Point Register (2 of 2)	
30527	Sensor Level - feet	Input Register	Floating Point Register (1 of 2)	
30528	Sensor Level - feet	Input Register	Floating Point Register (2 of 2)	
30529	Sensor Level - mm	Input Register	Floating Point Register (1 of 2)	
30530	Sensor Level - mm	Input Register	Floating Point Register (2 of 2)	
30531	Sensor Level - meters	Input Register	Floating Point Register (1 of 2)	
30532	Sensor Level - meters	Input Register	Floating Point Register (2 of 2)	
30549	Sensor A Volume - Gallons	Input Register	Floating Point Register (1 of 2)	Tank volume, not flow volume.
30550	Sensor A Volume - Gallons	Input Register	Floating Point Register (2 of 2)	Tank volume, not flow volume.
30551	Sensor A Volume - Liters	Input Register	Floating Point Register (1 of 2)	Tank volume, not flow volume.
30552	Sensor A Volume - Liters	Input Register	Floating Point Register (2 of 2)	Tank volume, not flow volume.
30553	Sensor A Volume - ft <sup>3</sup>	Input Register	Floating Point Register (1 of 2)	Tank volume, not flow volume.
30554	Sensor A Volume - ft <sup>3</sup>	Input Register	Floating Point Register (2 of 2)	Tank volume, not flow volume.

Register Address	Description	Register Type	Format Type	Comments
30555	Sensor A Volume - m <sup>3</sup>	Input Register	Floating Point Register (1 of 2)	Tank volume, not flow volume.
30556	Sensor A Volume - m <sup>3</sup>	Input Register	Floating Point Register (2 of 2)	Tank volume, not flow volume.
30557	Sensor A Volume - USMG	Input Register	Floating Point Register (1 of 2)	Tank volume, not flow volume.
30558	Sensor A Volume - USMG	Input Register	Floating Point Register (2 of 2)	Tank volume, not flow volume.
30559	Sensor A Volume - IG	Input Register	Floating Point Register (1 of 2)	Tank volume, not flow volume.
30560	Sensor A Volume - IG	Input Register	Floating Point Register (2 of 2)	Tank volume, not flow volume.
30561	Sensor A Volume - IMG	Input Register	Floating Point Register (1 of 2)	Tank volume, not flow volume.
30562	Sensor A Volume - IMG	Input Register	Floating Point Register (2 of 2)	Tank volume, not flow volume.
30563	Sensor A Volume - bbl	Input Register	Floating Point Register (1 of 2)	Tank volume, not flow volume.
30564	Sensor A Volume - bbl	Input Register	Floating Point Register (2 of 2)	Tank volume, not flow volume.
30709	Flow Temperature - F	Input Register	Floating Point Register (1 of 2)	
30710	Flow Temperature - F	Input Register	Floating Point Register (2 of 2)	
30711	Flow Temperature - C	Input Register	Floating Point Register (1 of 2)	
30712	Flow Temperature - C	Input Register	Floating Point Register (2 of 2)	
30904	Run Hours	Input Register	Floating Point Register (1 of 2)	
30905	Run Hours	Input Register	Floating Point Register (2 of 2)	
30923	Sensor Status	Input Register	Index (0-10)	0 = Sensor Good 4 = Sensor Open 5 = Sensor Short 7 = Low Signal
30925	Logging Status	Input Register	Index (0-2)	0 = Stopped 1 = Active 2 = Full
30926	Logging Used - %	Input Register	Floating Point Register (1 of 2)	
30927	Logging Used - %	Input Register	Floating Point Register (2 of 2)	
30928	mA Output 1 - 4mA Value	Input Register	Floating Point Register (1 of 2)	
30929	mA Output 1 - 4mA Value	Input Register	Floating Point Register (2 of 2)	
30930	mA Output 1 - 20mA Value	Input Register	Floating Point Register (1 of 2)	

Register Address	Description	Register Type	Format Type	Comments
30931	mA Output 1 - 20mA Value	Input Register	Floating Point Register (2 of 2)	
30940	mA Output 1 - Output Level	Input Register	Floating Point Register (1 of 2)	Current mA feedback on output # 1
30941	mA Output 1 - Output Level	Input Register	Floating Point Register (2 of 2)	Current mA feedback on output # 1
30947	Velocity Units	Input Register	Index (0 to 1)	0 = Feet per Second 1 = Meter per Second
30948	Flow Units	Input Register	Index (0 to 31)	0 = US Gallons per Minute 1 = Litres per Second 2 = Cubic Feet per Minute 3 = Cubic Meters per Hour 4 = US Gallons per Second 5 = US Gallons per Hour 6 = US Gallons per Day 7 = Cubic Feet per Second 8 = Cubic Feet per Hour 9 = Cubic Feet per Day 10 = US Million Gallons per Second 11 = US Million Gallons per Minute 12 = US Million Gallons per Hour 13 = US Million Gallons per Day 14 = Litres per Minute 15 = Litres per Hour 16 = Litres per Day 17 = Cubic Meters per Second 18 = Cubic Meters per Minute 19 = Cubic Meters per Day 20 = Imperial Gallons per Second 21 = Imperial Gallons per Minute 22 = Imperial Gallons per Hour 23 = Imperial Gallons per Day 24 = Imperial Million Gallons per Second 25 = Imperial Million Gallons per Minute 26 = Imperial Million Gallons per Hour 27 = Imperial Million Gallons per Day 28 = Barrels per Second 29 = Barrels per Minute 30 = Barrels per Hour 31 = Barrels per Day
30949	Linear Units	Input Register	Index (0 to 3)	0 = Feet 1 = Inches 2 = Millimeters 3 = Meters
30950	Volume Units	Input Register	Index (0 to 7)	0 = Cubic Feet 1 = US Gallons 2 = US Million Gallons 3 = Imperial Gallons 4 = Imperial Million Gallons 5 = Cubic Meters 6 = Litre 7 = Barrel

Register Address	Description	Register Type	Format Type	Comments
<b>30951</b>	Time Units	Input Register	Index (0 to 3)	0 = Second 1 = Minute 2 = Hour 3 = Day
<b>30961</b>	Echo Confidence	Input Register	Integer	

### ENCLOSURE HEATER AND THERMOSTAT - Option TH

Instruments can be factory-equipped with an Enclosure Heater and Thermostat or the module can be customer-installed. The Thermostat is factory set to turn ON at 40°F (4.5°C) and OFF at 60°F (15.5°C). Power consumption is 15 Watts.

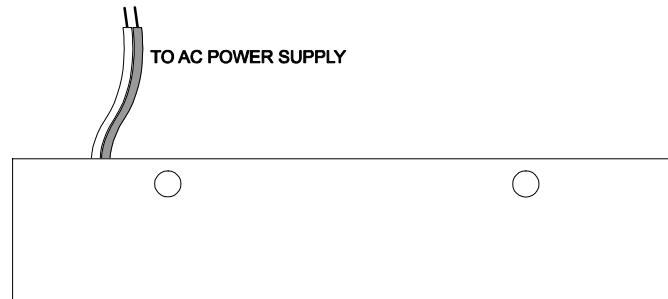

### ENCLOSURE SUNSCREEN - Option SCR

Do not mount instrument electronics in direct sunlight. Overheating will reduce the life of electronic components and condensate may form during the heat/cool cycles and cause electrical shorts.

#### Note:

Exposure to direct sunlight can cause overheating and moisture condensation which will reduce the operating life of electronics.

Protect Instruments from direct sunlight with this iridite finished aluminum sun screen (Option SCR).

Seal conduit entries with caulking compound to further reduce moisture condensation.

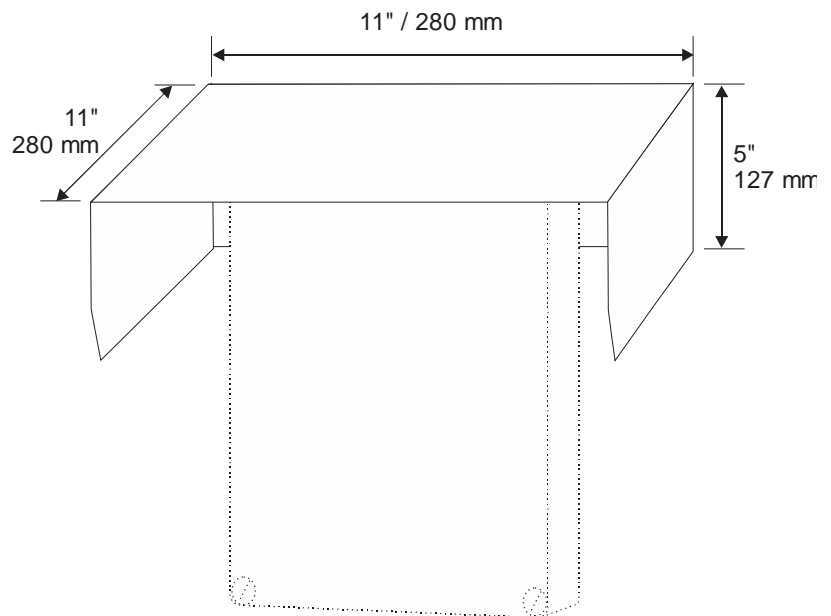

**POWER INPUT OPTION  
9-32VDC**

OCF 6.1 Level & Flow Monitors may be ordered factory-configured for 9-32VDC power input.

**QUICK BENCH TEST:**

Connect Sensor as shown below, then Power. When properly connected figures will show on the large LCD display. Test operation of the OCF 6.1 by holding the sensor steadily and aiming at a flat, stable target 12 to 28" (305 to 711 mm) away from the end of the sensor. Allow a few seconds for the OCF 6.1 to lock onto the target before displaying its distance. The OCF 6.1 will now display Range in ft or cm (factory calibration).

**CONNECTIONS:**

POWER INPUT: Connect 9-32VDC/0.5 Amps to the + and - terminals. The Power Input GND must be connected to the nearest Ground pole. A 1 amp fuse in line is recommended.

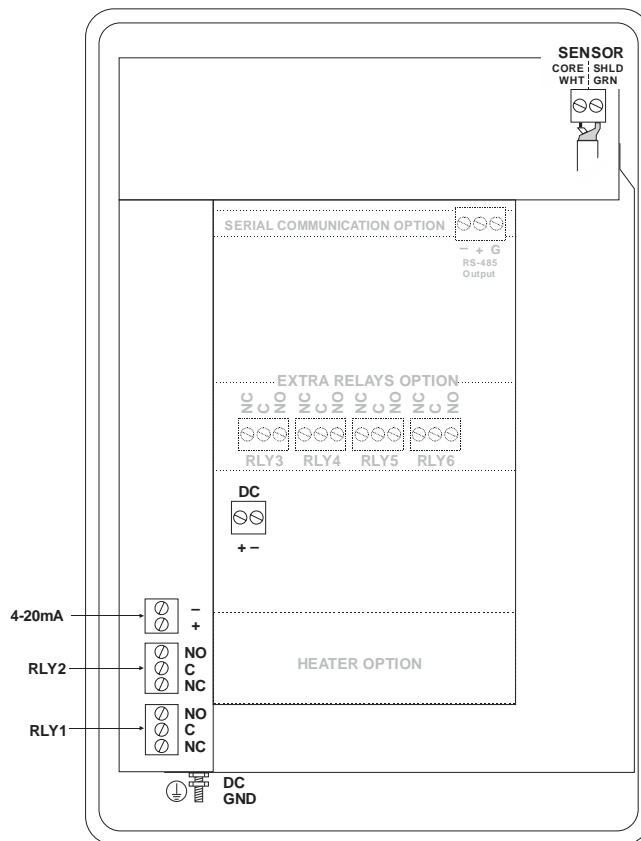

<b>CONVERSION GUIDE</b>		
<b>FROM</b>	<b>TO</b>	<b>MULTIPLY BY</b>
US GALLONS	CUBIC FEET	0.1337
US GALLONS	IMPERIAL GALS	0.8327
US GALLONS	LITRES	3.785
US GALLONS	CUBIC METERS	0.003785
LITRES/SEC	GPM	15.85
LITRES	CUBIC METERS	0.001
BARRELS	US GALLONS	42
BARRELS	IMPERIAL GALS	34.9726
BARRELS	LITRES	158.9886
INCHES	MM	25.4
DEGREES F	DEGREES C	$(^{\circ}\text{F}-32) \times 0.556$
POUNDS	KILOGRAMS	0.453
PSI	BAR	0.0676
FOOT <sup>2</sup>	METER <sup>2</sup>	0.0929

VOLUME CALCULATION FOR ROUND TANKS:  $3.142 \times R^2 \times H$

R = TANK RADIUS (½ TANK DIAMETER)

H = TANK HEIGHT

**SPECIFICATIONS**

- Accuracy:** ±0.25% of Measured Range or 2 mm, whichever is greater. Repeatability and Linearity: 0.1% F.S.
- Displays:** White, backlit matrix - displays flow rate, totalizer, relay states, operating mode and calibration menu
- Calibration:** built-in 5-key calibrator with English, French or Spanish language
- Power Input:** 100-240VAC, 50/60Hz, 10 VA or  
Optional 9-32VDC, rated 10W
- Output:** Isolated 4-20mA (1000 ohm load max.)
- Control Relays:** Qty 2, rated 5 amp 240VAC SPDT, programmable flow alarm and/or proportional pulse
- Enclosure:** watertight, dust tight NEMA4X (IP 66) polycarbonate with a clear shatter-proof face
- Environmental Conditions:** Relative humidity up to 80% -23 to 60°C ambient temperature, maximum 5000 m altitude, pollution degree 4, Installation Category II.
- Sensitivity:** adjustable. Damping: adjustable
- Electrical Surge Protection:** Sensor, 4-20mA output and AC power input
- Approximate Shipping Weight:** 10 lbs (4.5 kg)

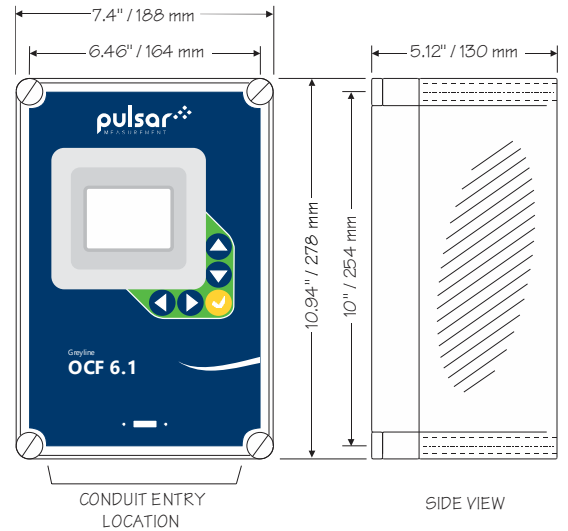

**Standard Sensor PZ15**

- Maximum Range:** 15 ft (4.57 m)
- Minimum Range (Deadband):** 8" (203.2 mm)
- Operating Frequency:** 92 KHz
- Beam Angle:** 8°
- Operating Temperature:** -40° to 150° (-40° to 65°C)
- Temperature Compensation:** Automatic, continuous
- Max. Operating Pressure:** 20 psi (1.35 bar)
- Sensor Face:** PVC
- Sensor Body:** PVC
- Mounting:** 3/4" NPT
- Cable Length:** 25 ft. (7.6 m) continuous RG62AU coaxial. Optional 50 ft. (15 m) continuous 500 ft. (152 m) RG62AU coaxial (splice)
- Max. Cable Length:** 500 ft. (152 m) RG62AU coaxial (splice)
- Hazardous Rating:** CSA rated Intrinsically Safe Class I, Groups C,D, Class II, Groups E,F,G with Optional Intrinsic Safety Barrier.

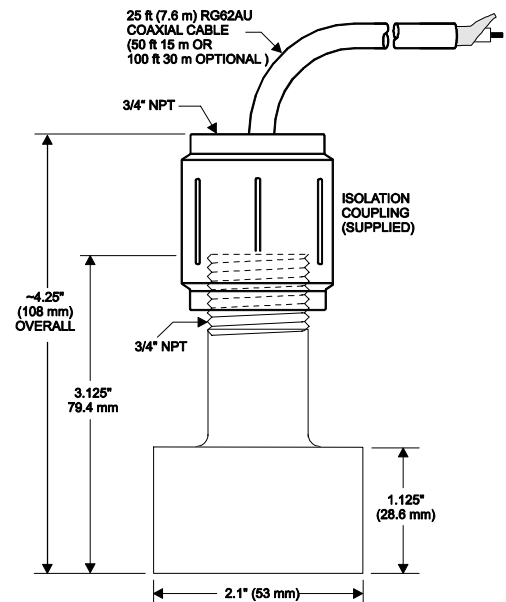

**Optional Sensor PZ32T**

- Maximum Range:** 32 ft. (10 m)
- Deadband (blinking):** Programmable, minimum 12" (305 mm)
- Beam Angle:** 8° at 3 DB
- Temperature Compensation:** Automatic, continuous
- Operating Frequency:** 42 KHz
- Exposed Materials:** PVC and Teflon
- Operating Temperature:** -40° to 150°F (-40° to 65°C)
- Operating Pressure:** 20 psi (1.35 Bar) maximum
- Mounting:** ¾" NPT (PVC isolation coupling supplied)
- Sensor Cable:** RG62AU coaxial, 25 ft. (7.6 m) standard
- Hazardous Rating:** with optional Intrinsic Safety Barrier: CSA, Class I,II,III, Div. I,II, Groups C,D,E,F,G  
Note: Max Range reduced to 25 ft (7.6 m) with ISB option.

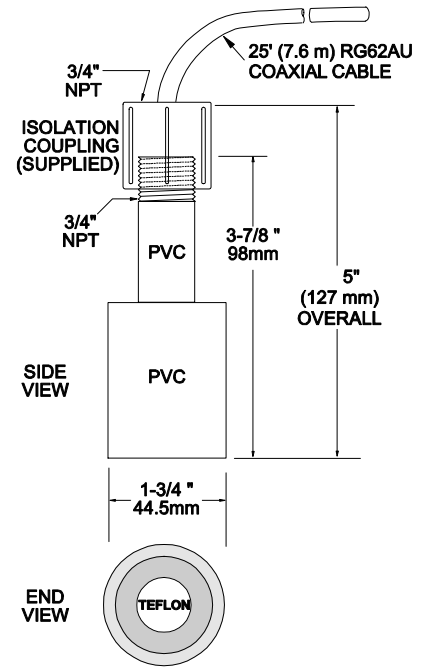

**Standard PZ34**

- Maximum Range:** 32 ft. (10 m)
- Minimum Range (Deadband):** 16" (406.4 mm)
- Operating Frequency:** 46 KHz
- Beam Angle:** 8°
- Temperature Compensation:** Automatic, continuous
- Operating Temperature:** -40° to 150°F (-40° to 65°C)
- Maximum Operating Pressure:** 20 psi (1.35 Bar)
- Exposed Materials:** PVC
- Sensor Mounting:** ¾" NPT
- Maximum Cable Length:** 500 ft (152 m)
- Optional Hazardous Rating:** CSA rated Intrinsically Safe Class I, Groups C,D, Class II, Groups E,F,G with optional Intrinsic Safety Barrier.  
Note: Max Range reduced to 25 ft (7.8 m) with ISB option.

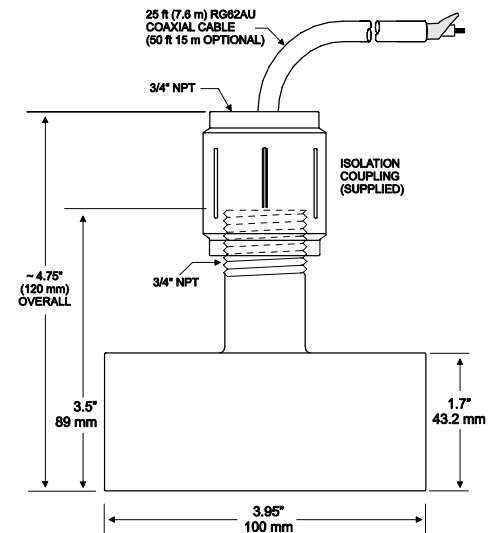



**[www.pulsarmeasurement.com](http://www.pulsarmeasurement.com)**  
**[service@pulsarmeasurement.com](mailto:service@pulsarmeasurement.com)**

*Copyright © 2020 Pulsar Measurement Ltd.  
Registered Address: 1 Chamberlain Square CS, Birmingham B3 3AX  
Registered No.: 3345604 England & Wales  
Rev 1.0*