



OPTIFLUX 5000 Technical Datasheet

Electromagnetic flowmeter in sandwich version

- Exceptional long-term stability and accuracy
- For highly aggressive and abrasive fluids
- Fully vacuum-resistant with high-tech ceramic liners



The documentation is only complete when used in combination with the relevant documentation for the signal converter.

1 Product features	3
1.1 Solution with high-tech ceramics	3
1.2 Options and variants	5
1.3 Measuring principle	6
2 Technical data	7
2.1 Technical data	7
2.2 Measuring accuracy	12
2.3 Dimensions and weights	14
3 Installation	18
3.1 Intended use	18
3.2 General notes on installation	18
3.2.1 Vibrations	18
3.2.2 Magnetic field	18
3.3 Installation conditions	19
3.3.1 Inlet and outlet	19
3.3.2 Bends in 2 or 3 dimensions	19
3.4 Bends	20
3.5 T-section	21
3.6 Open discharge	21
3.7 Control valve	22
3.8 Pump	22
3.9 Air venting and vacuum forces	23
3.10 Flange deviation	24
3.11 Mounting position	24
3.12 Mounting	25
3.12.1 Torques and pressure	25
4 Electrical connections	27
4.1 Safety instructions	27
4.2 Grounding	27
4.3 Virtual reference option	28
5 Notes	29

1.1 Solution with high-tech ceramics

The **OPTIFLUX 5000** is one of the most accurate flowmeters available in the market today. This is the result of a special tube design with conical parts, optimizing the flow profile. Leading metrological institutes use the **OPTIFLUX 5000** as their master meter in combination with the high-end signal converter IFC 300.

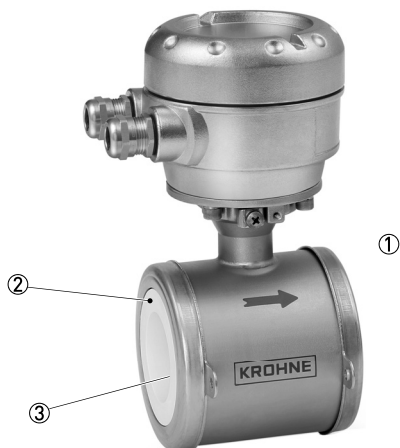

- ① Sandwich design
- ② Ceramic liner
- ③ Cermet or Platinum electrodes



Ceramic durability

By implementing oxide ceramics, KROHNE is using a technically superior material for electromagnetic flowmeters (EMF) and pressure measuring devices that is permanently resistant to corrosive and abrasive media. Additionally, ceramic is immune to temperature shocks and absolutely safe against gas discharge and leaks – all in all a unique combination for high-performance applications in all industrial sectors.

Highlights

- Excellent long-term stability and accuracy
- Unique flow tube
- Fused in-place Cermet or Platinum electrodes
- Custody transfer standard of international metrological authorities
- For highly aggressive and abrasive fluids
- Resistant to a full vacuum
- High-tech ceramic liners
- Insensitive against temperature shocks

Industries

- Chemical
- Paper & Pulp
- Water and wastewater
- Minerals & Mining
- Food & beverage
- Machinery

Applications

- Master transfer meter
- Precise volumetric dosing of additives
- Chemical injection
- For acids, alkaline, abrasive slurries and many other aggressive media

1.2 Options and variants



The OPTIFLUX 5000 sandwich version is available in a diameter range of DN2.5 up to DN100 - 1/10" up to 4".

The flow sensor is offered in a large range of pressure ratings and is configurable with the IFC 050, IFC 100, IFC 300 and the IFC 400 signal converter.

Can be ordered in stainless steel version and is also optionally suitable in hazardous areas. Grounding rings are available in high grade alloys.

The installation of the OPTIFLUX 5000 can be simplified by choosing the virtual reference option. Grounding rings can then be omitted. This option can only be combined with the IFC 300 / IFC 400 signal converter.

1.3 Measuring principle

An electrically conductive fluid flows inside an electrically insulated pipe through a magnetic field. This magnetic field is generated by a current, flowing through a pair of field coils.

Inside of the fluid, a voltage U is generated:

$$U = v * k * B * D$$

in which:

v = mean flow velocity

k = factor correcting for geometry

B = magnetic field strength

D = inner diameter of flowmeter

The signal voltage U is picked off by electrodes and is proportional to the mean flow velocity v and thus the flow rate Q . A signal converter is used to amplify the signal voltage, filter it and convert it into signals for totalizing, recording and output processing.

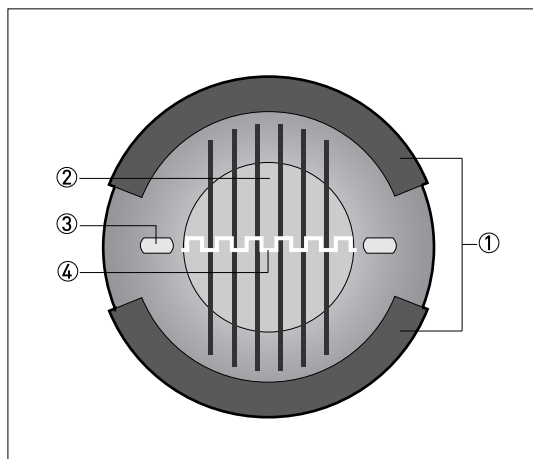

Figure 1-1: Measuring principle

- ① Field coils
- ② Magnetic field
- ③ Electrodes
- ④ Induced voltage (proportional to flow velocity)

2.1 Technical data

- The following data is provided for general applications. If you require data that is more relevant to your specific application, please contact us or your local sales office.
- Additional information (certificates, special tools, software,...) and complete product documentation can be downloaded free of charge from the website (Downloadcenter).

Measuring system

Measuring principle	Faraday's law
Application range	This electromagnetic flowmeter is designed exclusively to measure the flow of electrically conductive, liquid media.
Measured value	
Primary measured value	Flow velocity
Secondary measured value	Volume flow, mass flow, electrical conductivity, coil temperature

Design

Features	Sandwich version with optimized flow sensor
Modular construction	The measurement system consists of a flow sensor and a signal converter. It is available as compact and as separate version. More information about the signal converter can be found in the documentation of the signal converter
Compact version	With IFC 050 signal converter: OPTIFLUX 5050 C
	With IFC 100 signal converter: OPTIFLUX 5100 C
	With IFC 300 signal converter: OPTIFLUX 5300 C DN2.5...15 / 1/10...1/2" is only available with aluminum signal converter housing
	With IFC 400 signal converter: OPTIFLUX 5400 C DN2.5...15 / 1/10...1/2" is only available with aluminum signal converter housing
Remote version	In wall (W) mount version with IFC 050 signal converter: OPTIFLUX 5050 W
	In wall (W) mount version with IFC 100 signal converter: OPTIFLUX 5100 W
	In field (F), wall (W) or rack (R) mount version with IFC 300 signal converter: OPTIFLUX 5300 F, W or R
	In field (F), wall (W) or rack (R) mount version with IFC 400 signal converter: OPTIFLUX 5400 F, W or R
Nominal diameter	DN2.5...100 / 1/10...4"

Measuring accuracy

Maximum measuring error	IFC 050: down to 0.5% of the measured value \pm 1 mm/s
	IFC 100: down to 0.3% of the measured value \pm 1 mm/s
	IFC 300 and IFC 400: down to 0.15% of the measured value \pm 1 mm/s
	Optionally: optimised accuracy for IFC 050 and IFC 100. For more details on optimised accuracy, see the concerning signal converter
	The maximum measuring error depends on the installation conditions.
	For detailed information refer to <i>Measuring accuracy</i> on page 12.
Repeatability	\pm 0.1% of MV, minimum 1 mm/s
Calibration	Standard: 2 point calibration by direct volume comparison. Optional: special calibration on request.

Operating conditions

Temperature	
Process temperature	Compact version: -40...+140°C / -40... +284°F Size DN 2.5...15 / 1/10...1/2": -20...+120°C / -4... +248°F
	Remote version: -40...+180°C / -40...+356°F Size DN 2.5...15 / 1/10...1/2": -20...+180°C / -4... +356°F
	For Ex versions different temperature ranges are applicable. Please see the relevant Ex documentation for details.
Maximum temperature change (shock)	DN2.5...25 / 1/10...1": < 3 K/s DN40...100 / 1 1/2...4": < 0.2 K/s
Ambient temperature	-40...+65°C / -40...+149°F For IFC 100 stainless steel: -40...+60°C / -40...+140°F
	For Ex versions different temperature ranges are applicable. Please see the relevant Ex documentation for details.
Storage temperature	-50...+70°C / -58...+158°F
Measurement range	-12...+12 m/s / -40...+40 ft/s
Pressure	
Ambient	Atmospheric
Nominal flange pressure	
EN 1092-1	Standard:
	DN100: PN 16
	DN2.5...80: PN 40
	Option:
DN100: PN 25	
ASME B16.5	Standard:
	1/10...4": 150 lb
	Option:
	1/10...4": 300 lb
Vacuum load	0 mbar / 0 psi
Pressure ranges for secondary containment	Pressure resistant up to 40 bar / 580 psi
	Burst pressure up to ± 160 bar / 2320 psi
Chemical properties	
Physical condition	Electrically conductive liquids
Electrical conductivity	Standard measurement
	For detailed information refer to the relevant signal converter document.
Permissible gas content (volume)	≤ 5%
Permissible solid content (volume)	IFC 050: ≤ 10%
	IFC 100: ≤ 10%
	IFC 300 / IFC 400: ≤ 70%

Installation conditions

Installation	Take care that the flow sensor is always fully filled.
	For detailed information refer to <i>Installation</i> on page 18.
Flow direction	Forward and reverse.
	Arrow on the flow sensor indicates positive flow direction.
Inlet run	≥ 5 DN (without disturbing flow, after a single 90° bend)
	≥ 10 DN (after a double bend = 2 x 90°)
Outlet run	≥ 2 DN
Dimensions and weights	For detailed information refer to <i>Dimensions and weights</i> on page 14.

Materials

Flow sensor housing	DN2.5...15 / 1/10...1/2": stainless steel 1.4408 / 316
	DN25...100 / 1...4": stainless steel 1.4301 / 304
Flow sensor	Ceramic
Connection box (remote versions only)	Standard:
	Polyurethane coated die-cast aluminum
	Option: Stainless steel
Grounding rings	Standard:
	Stainless steel
	Option:
	Hastelloy® C, titanium, tantalum
	Other materials on request.
Grounding rings can be omitted with virtual reference option for the IFC 300 / IFC 400 signal converter.	
Mounting materials	Standard: rubber centering sleeves
	Option: stud bolts and nuts in stainless steel or galvanized steel
Gaskets	DN2.5...15 / 1/10...1/2"; O-rings: FKM, EPDM, FFKM DN25...100 / 1...4"; flat gaskets: filled PTFE, Graphite. PTFE envelope: only in combination with tantalum grounding rings.
	Other materials on request.
Measuring electrodes	DN2.5...25 / 1/10...1": Cermet
	DN40...100 / 1 1/2...4": Platinum

Process connections

EN 1092-1	Standard:
	DN100: PN 16
	DN2.5...80: PN 40
	Option:
	DN100: PN 25
ASME	Standard:
	1/10...4": 150 lb
	Option:
	1/10...4": 300 lb
JIS	DN2.5...100: 10...20 K

Electrical connections

For more details; see the relevant documentation of the signal converter	
Signal cable (remote versions only)	
Type A (DS)	In combination with the IFC 100, IFC 300 and IFC 400 signal converter Standard cable, double shielded. Max. length: 600 m / 1950 ft (depends on electrical conductivity and the flow sensor).
Type B (BTS)	Only in combination with the IFC 300 and IFC 400 signal converter Optional cable, triple shielded. Max. length: 600 m / 1950 ft (depends on electrical conductivity and the flow sensor).
I/O	For more details of I/O options, including data streams and protocols, see technical datasheet of the relevant signal converter.

Approvals and certifications

CE	
This device fulfils the statutory requirements of the relevant directives. The manufacturer certifies successful testing of the product by applying the conformity mark on the device.	
	For more information on the directives, standards and the approved certifications, please refer to the declaration of conformity supplied with the device or downloadable from the manufacturer's website.
Hazardous areas	
Non-Ex	Standard
ATEX	KEMA 04 ATEX 2126 X
	ATEX II 2 GD EEx me ia IIC T6...T3
	ATEX II 2 GD EEx de ia IIC T6...T3
	For more details, see Ex documentation of the flow sensor and signal converter.
FM	Class I, Div 2, groups A, B, C and D
	Class II, Div 2, groups F and G
	Class III, Div 2, groups F and G
CSA	Class I, Div 2, groups A, B, C and D
	Class II, Div 2, groups F and G
IECEX	Pending
NEPSI	Sensor: GYJ20.1384X
	Ex e ia mb IIC T3...T6 Gb (DN2.5...15)
	Ex d e ia IIC T3...T6 Gb (DN25...100)
	Compact version: GYJ20.1383X
	Ex d e ia [ia] mb IIC T3...T6 Gb (DN2.5...15)
	Ex d ia [ia] IIC T3...T6 Gb (DN25...100)
	Ex d e ia [ia] IIC T3...T6 Gb (DN25...100)
Protection category acc. to IEC 60529	Standard: IP66/67, NEMA 4/4X/6
	Option: IP68, NEMA 6P
	IP68 is only available for remote designs and with a stainless steel connection box.
	IP67/69 with IFC 100 stainless steel signal converter
Hygiene	FDA approved materials.
Shock test	IEC 60068-2-27
	30 g for 18 ms
Vibration test	IEC 60068-2-64
	f = 20...2000 Hz, rms = 4.5 g, t = 30 min.

2.2 Measuring accuracy

Every electromagnetic flowmeter is calibrated by direct volume comparison. The wet calibration validates the performance of the flowmeter under reference conditions against accuracy limits.

The accuracy limits of electromagnetic flowmeters are typically the result of the combined effect of linearity, zero point stability and calibration uncertainty.

Reference conditions

- Medium: water
- Temperature: +5...+35°C / +41...+95°F
- Operating pressure: 0.1...5 barg / 1.5...72.5 psig
- Inlet section: ≥ 5 DN
- Outlet section: ≥ 2 DN

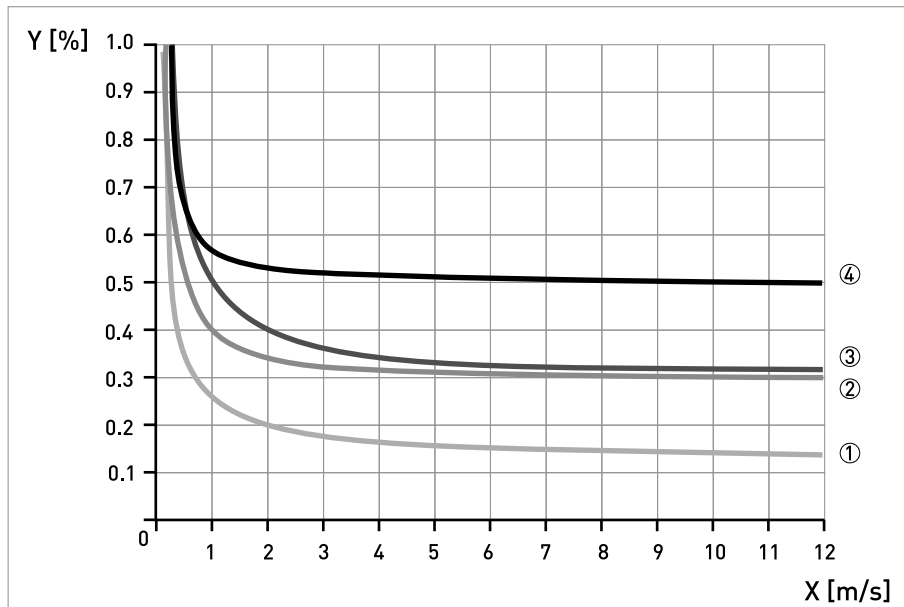

Figure 2-1:
X [m/s]: flow velocity
Y [%]: deviation from the actual measured value (mv)

In combination with the IFC 300 / IFC 400

	Accuracy	Curve
DN2.5...6 / 1/10...1/4"	0.3% of mv + 2 mm/s	③
DN10...100 / 3/8... 4"	0.15% of mv + 1 mm/s	①

In combination with the IFC 100

	Accuracy	Curve
DN2.5...6 / 1/10...1/4"	0.4% of mv + 1 mm/s	As ② + 0.1%
DN10...100 / 3/8...4"	0.3% of mv + 1 mm/s	②

In combination with the IFC 050

	Accuracy	Curve
DN2.5...6 / 1/10...1/4"	0.5% of mv + 1 mm/s	④
DN10...100 / 3/8...4"	0.5% of mv + 1 mm/s	

*Optionally for IFC 050 and IFC 100; extended calibration at 2 points for optimised accuracy.
For more details on optimised accuracy, see the concerning signal converter documentation.*

2.3 Dimensions and weights

<p>Remote version: DN2.5...15 / 1/10...1/2"</p>		<p>a = 88 mm / 3.5" b = 139 mm / 5.5" ① c = 106 mm / 4.2" Total height = H + a</p>
<p>Remote version: DN25...100 / 1...4"</p>		<p>a = 88 mm / 3.5" b = 139 mm / 5.5" ① c = 106 mm / 4.2" Total height = H + a</p>
<p>Compact version with IFC 300</p>		<p>a = 155 mm / 6.1" b = 230 mm / 9.1" ① c = 260 mm / 10.2" Total height = H + a</p>
<p>Compact version with IFC 400</p>		<p>a = 160 mm / 6.3" b = 240 mm / 9.5" ① c = 260 mm / 10.2" Total height = H + a</p>
<p>Compact version with IFC 100 (0°)</p>		<p>a = 82 mm / 3.2" b = 161 mm / 6.3" ① c = 257 mm / 10.1" ① Total height = H + a</p>

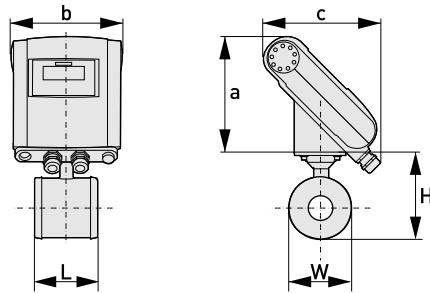
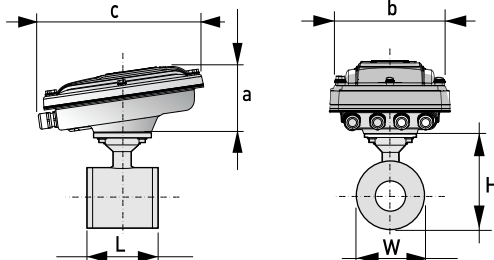
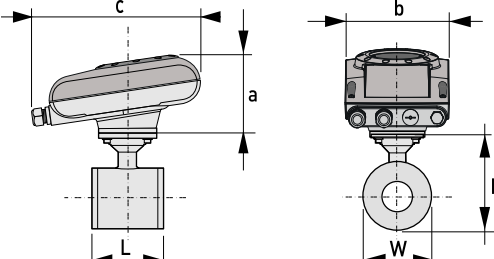
<p>Compact version with IFC 100 (45°)</p>		<p>a = 186 mm / 7.3" b = 161 mm / 6.3" c = 184 mm / 2.7" ① Total height = H + a</p>
<p>Compact stainless steel version with IFC 100 (10°)</p>		<p>a = 100 mm / 4" b = 187 mm / 7.36" ① c = 270 mm / 10.63" Total height = H + a</p>
<p>Compact version with IFC 050 (10°)</p>		<p>a = 100 mm / 4" b = 157 mm / 6.18" ① c = 260 mm / 10.24"</p>

① The value may vary depending on the used cable glands.

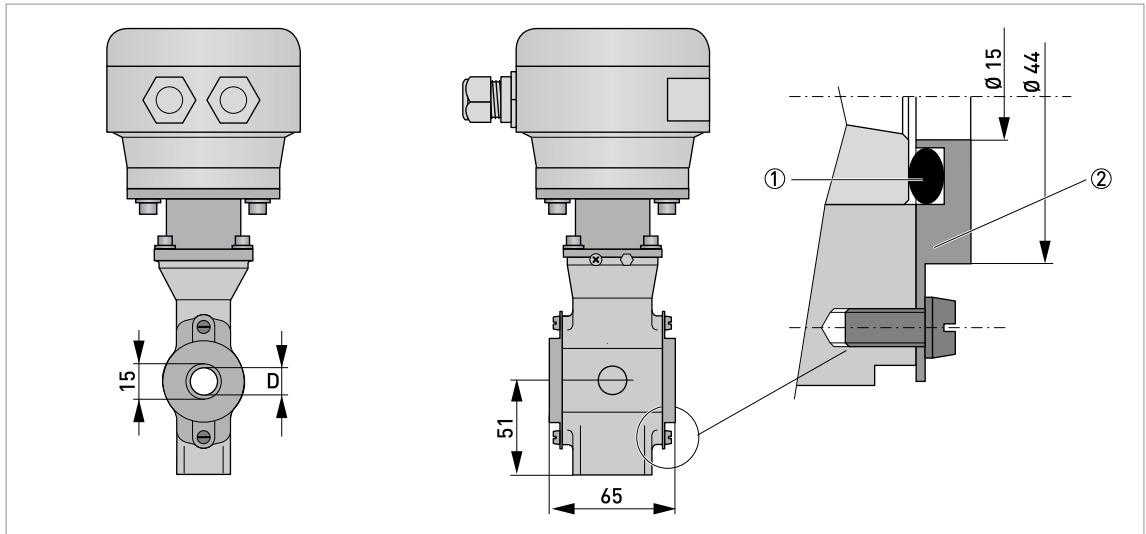

Figure 2-2: Construction details DN2.5...15 / 1/10...1/2"

- ① O-ring
- ② Grounding ring

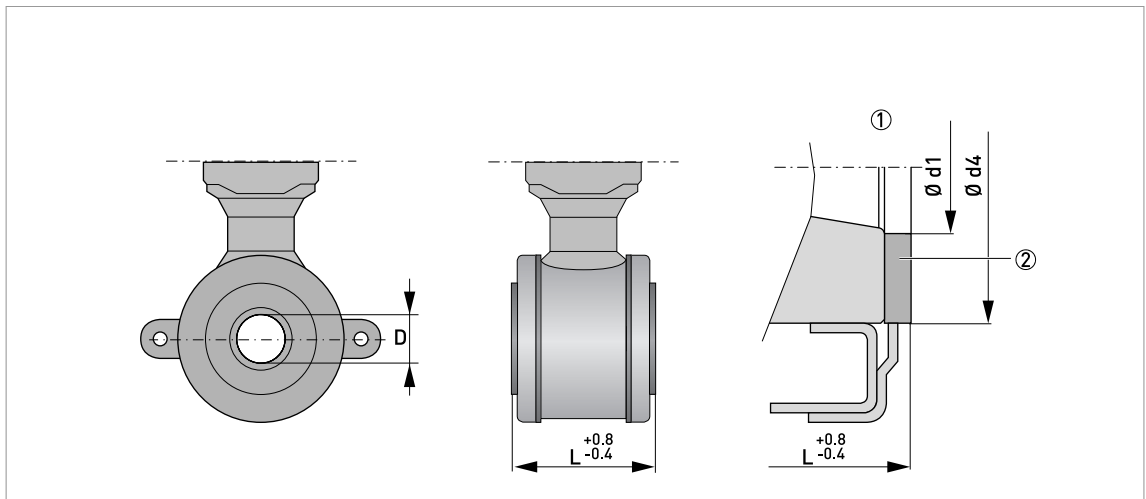

Figure 2-3: Construction details DN25...100 / 1...4"

- ① Situation without grounding rings
- ② Gasket

- All data given in the following tables are based on standard versions of the flow sensor only.
- Especially for smaller nominal sizes of the flow sensor, the signal converter can be bigger than the flow sensor.
- Note that for other pressure ratings than mentioned, the dimensions may be different.
- For full information on signal converter dimensions see relevant documentation.

Nominal size	Dimensions [mm]						Approx. weight [kg]
	DN	L	H	W	D	Ød1	
2.5	65 ①	123	44	2	6	-	1.6
4	65 ①	123	44	3.2	7	-	1.6
6	65 ①	123	44	4.8	9	-	1.6
10	65 ①	123	44	7	12	-	1.6
15	65 ①	123	44	12	14	-	1.6
25	58 ②	116	68	20	26	46	1.6
40	83 ②	131	83	30	39	62	2.4
50	103 ②	149	101	40	51	74	2.9
80	153 ②	181	133	60	80	106	6.4
100	203 ②	206	158	80	101	133	8.8

① Total fitting length of flowmeter with integrated rings: dimension L + 2 x gasket thickness.

② Total fitting length of flowmeter without rings: dimension L only.

Nominal size	Dimensions [inches]						Approx. weight [lb]
	ASME	L	H	W	D	Ød1	
1/10"	2.56 ①	4.84	1.73	0.08	0.24	-	3.53
1/6"	2.56 ①	4.84	1.73	0.13	0.28	-	3.53
1/4"	2.56 ①	4.84	1.73	0.19	0.35	-	3.53
3/8"	2.56 ①	4.84	1.73	0.28	0.47	-	3.53
1/2"	2.56 ①	4.84	1.73	0.47	0.55	-	3.53
1"	2.28 ②	4.57	2.68	0.79	1.02	1.81	3.53
1 1/2"	3.27 ②	5.16	3.27	1.18	1.54	2.44	5.29
2"	4.06 ②	5.87	3.98	1.57	2.01	2.91	6.39
3"	6.02 ②	7.13	5.24	2.36	3.15	4.17	14.11
4"	7.99 ②	8.11	6.22	3.15	3.98	5.24	19.40

① Total fitting length of flowmeter with integrated rings: dimension L + 2 x gasket thickness.

② Total fitting length of flowmeter without rings: dimension L only.

3.1 Intended use

Responsibility for the use of the measuring devices with regard to suitability, intended use and corrosion resistance of the used materials against the measured fluid lies solely with the operator.

The manufacturer is not liable for any damage resulting from improper use or use for other than the intended purpose.

The **OPTIFLUX 5000** flowmeter measures the volumetric flow rate of electrically conductive liquids, acids, alkaline solutions, pastes and slurries, also with very high solid contents.

3.2 General notes on installation

Inspect the packaging carefully for damages or signs of rough handling. Report damage to the carrier and to the local office of the manufacturer.

Do a check of the packing list to make sure that you have all the elements given in the order.

Look at the device nameplate to ensure that the device is delivered according to your order. Check for the correct supply voltage printed on the nameplate.

3.2.1 Vibrations

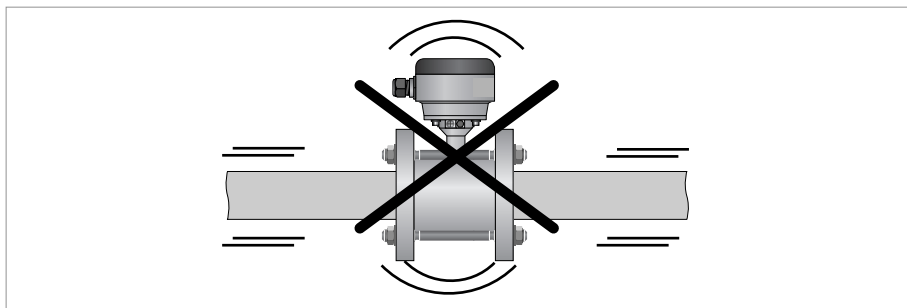

Figure 3-1: Avoid vibrations

3.2.2 Magnetic field

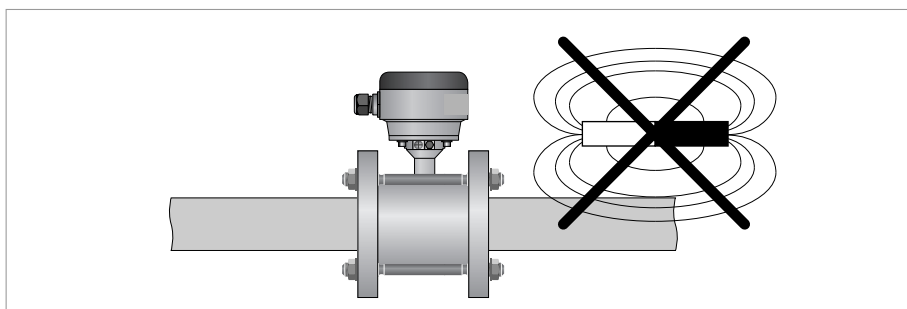

Figure 3-2: Avoid magnetic fields

3.3 Installation conditions

For the highest measuring accuracy, respect the recommended inlet and outlet lengths in the following paragraphs. The flow sensor in combination with the IFC 300 signal converter, can be installed in a 0D/0D configuration (no inlet and no outlet length).

3.3.1 Inlet and outlet

Use straight inlet and outlet pipe sections to prevent flow distortion or swirl, caused by bends and T-sections.

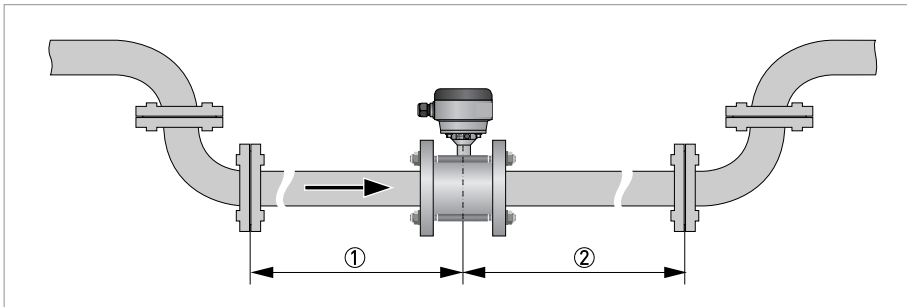

Figure 3-3: Recommended inlet and outlet section

- ① Refer to chapter "Bends in 2 or 3 dimensions"
- ② ≥ 2 DN

3.3.2 Bends in 2 or 3 dimensions

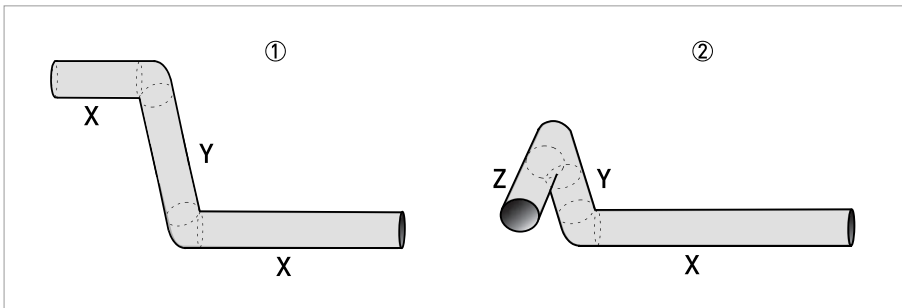

Figure 3-4: 2 and/or 3 dimensional bends upstream of the flowmeter

- ① 2 dimensions = X/Y
- ② 3 dimensions = X/Y/Z

Inlet length: using bends in 2 dimensions: ≥ 5 DN; when having bends in 3 dimensions: ≥ 10 DN

*2 dimensional bends occur in a vertical **or** horizontal plane (X/Y) only, while 3 dimensional bends occur in both vertical **and** horizontal plane (X/Y/Z).*

3.4 Bends

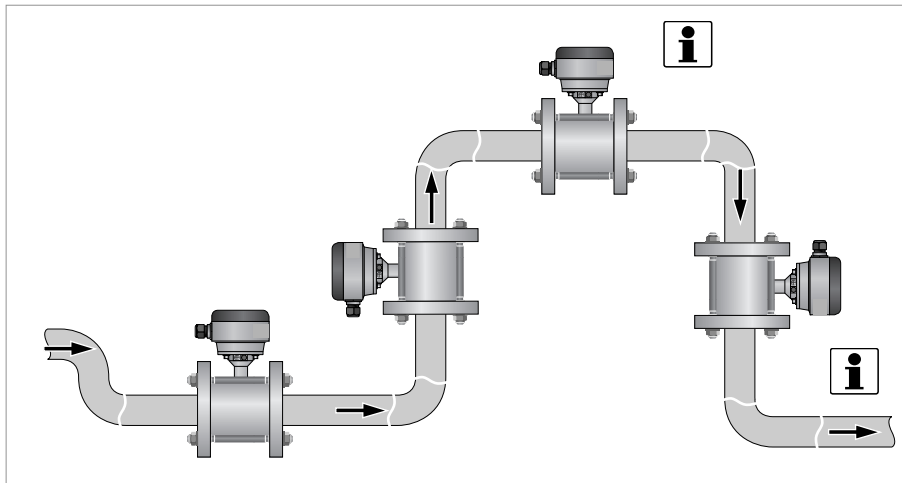

Figure 3-5: Installation in bending pipes (90°)

NOTE!

Recommended installation positions are at a lowered or ascending section of the pipeline installation. Installation at the highest point will enlarge the risk of flowmeter malfunction, because of air/gas bubbles.

Vertical installation in combination with an open discharge has to be avoided.

Vertical installation with a controlled back-pressure is possible.

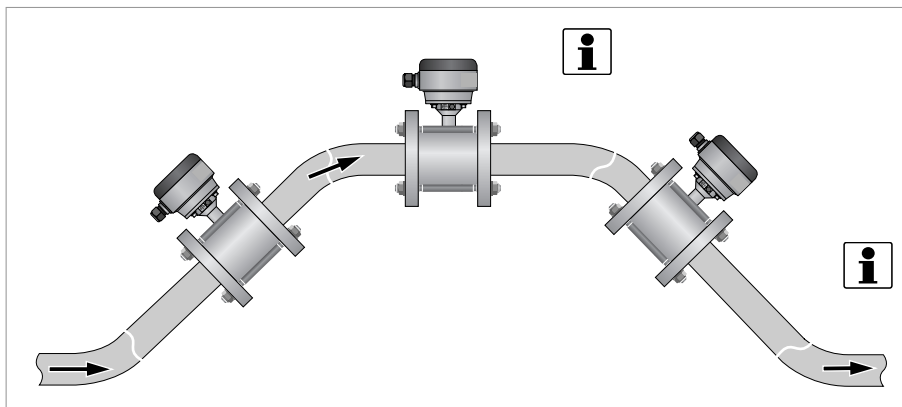

Figure 3-6: Installation in bending pipes (45°)

Avoid draining or partial filling of the flow sensor.

NOTE!

Vertical installation on a descending slope in the pipeline is only recommended when the back-pressure is controlled.

3.5 T-section

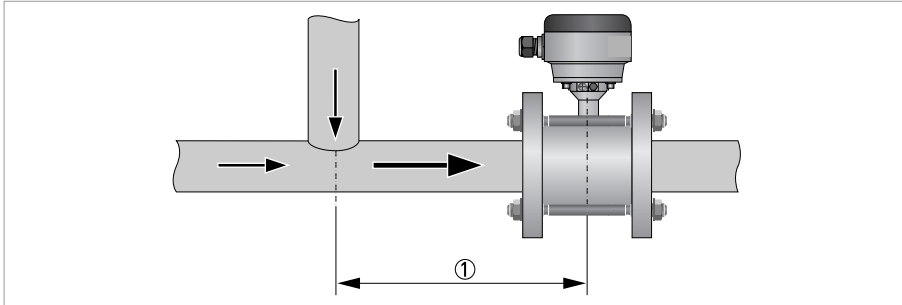

Figure 3-7: Distance behind a T-section

① $\geq 10 \text{ DN}$

3.6 Open discharge

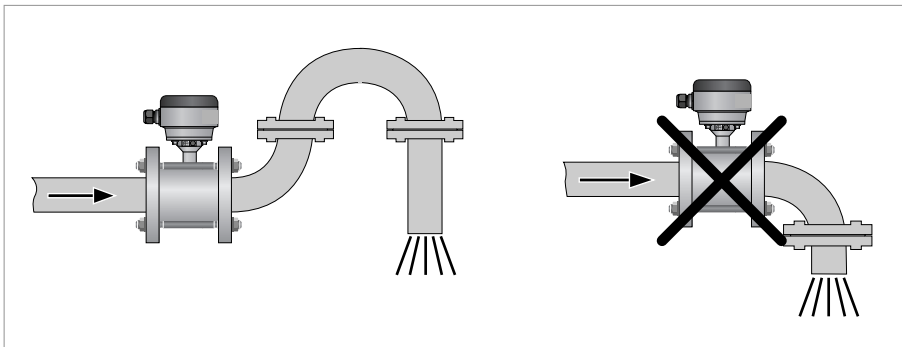

Figure 3-8: Installation in front of an open discharge

3.7 Control valve

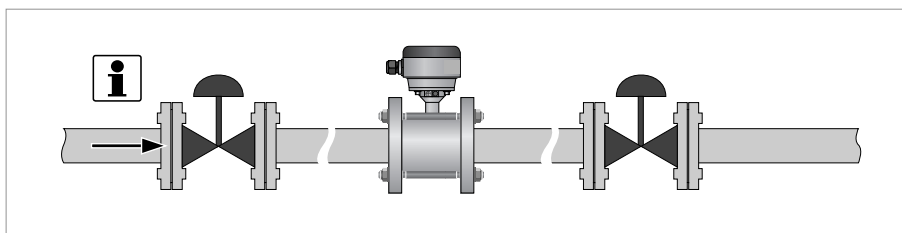

Figure 3-9: Installation in front of a control valve

NOTE!

Recommended position to install a flowmeter is upstream a control valve.

An electromagnetic flowmeter can be installed downstream of the control valve if there is no cavitation in the pipeline system (e.g. flow profile disturbances are resolved).

3.8 Pump

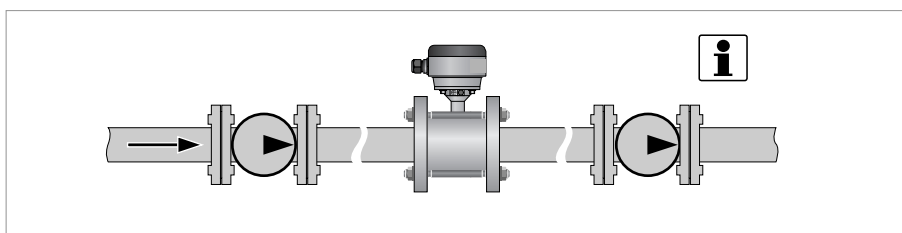

Figure 3-10: Installation behind a pump

NOTE!

Recommended position to install a flowmeter is downstream a pump (on a position where the flow disturbances of the pump are resolved).

An electromagnetic flowmeter can be installed in the suction line of a pump if there is no cavitation in the pipeline system.

3.9 Air venting and vacuum forces

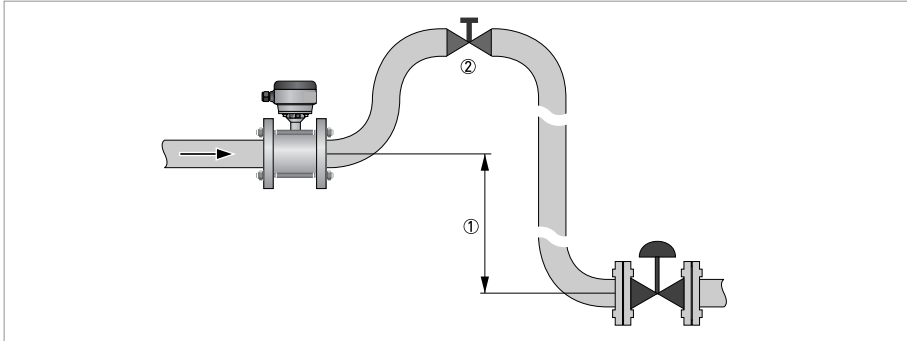

Figure 3-11: Air venting

- ① $\geq 5 \text{ m} / 17 \text{ ft}$
- ② Air ventilation point

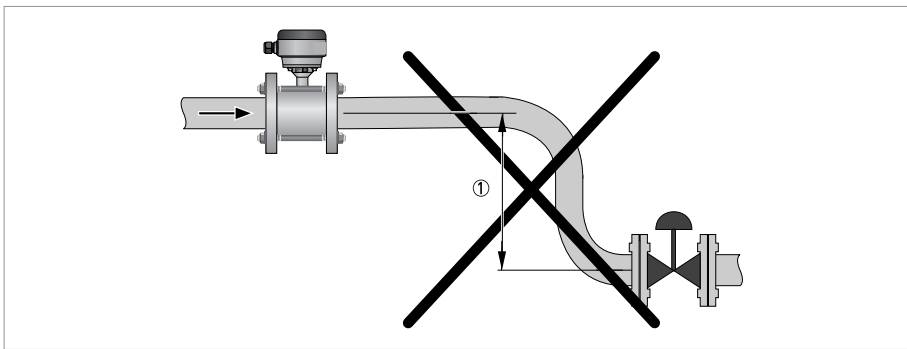

Figure 3-12: Vacuum

- ① $\geq 5 \text{ m} / 17 \text{ ft}$

3.10 Flange deviation

Max. permissible deviation of pipe flange faces:
 $L_{max} - L_{min} \leq 0.5 \text{ mm} / 0.02''$

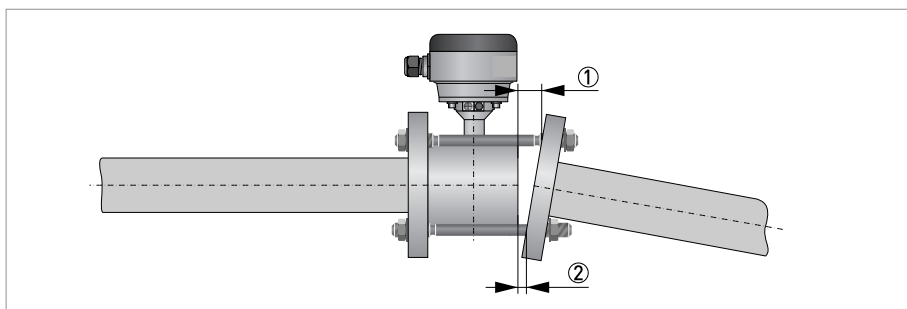

Figure 3-13: Flange deviation

- ① L_{max}
- ② L_{min}

3.11 Mounting position

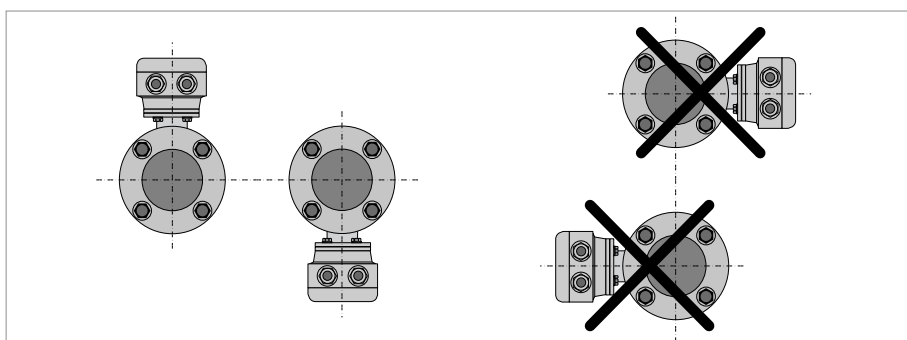

Figure 3-14: Mounting position

- Install the flow sensor with the signal converter aligned upwards or downwards.
- Install the flow sensor in line with the pipe axis.

3.12 Mounting

3.12.1 Torques and pressure

- Please use stainless steel A2 / 6.9 class bolts.
- Make sure the connecting flanges are of type raised face (RF).

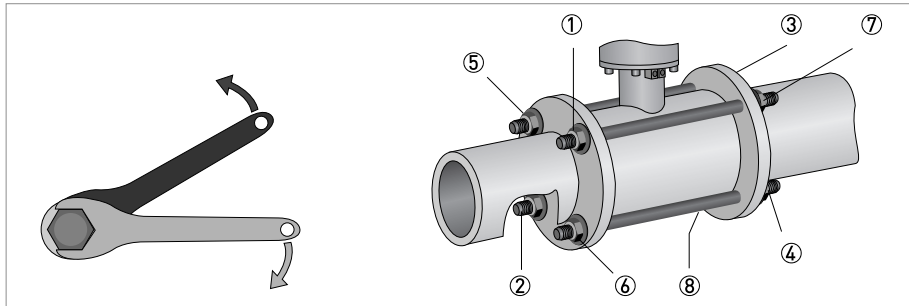

Figure 3-15: Tighten the bolts in fixed order, see picture.

Max. torque:

- Step 1: approx. 50% of max. torque
- Step 2: approx. 80% of max. torque
- Step 3: 100% of max. torque given in tables

EN 1092-1

Nominal size DN [mm]	Pressure rating	Max. allowable operating pressure [bar]
2.5...80	PN 40	40
100	PN 16	16
100	PN 25	25

ASME B 16.5

Nominal size [inch]	Pressure rating	Max. allowable operating pressure [psig]
1/10...4"	150 lb	230
1/10...3"	300 lb	580

- Pressures at 20°C / 68°F.
- For higher temperatures, the pressure and temperature ratings are as per ASME B16.5.

The specified torque values are dependent on variables (temperature, bolt material, gasket material, lubricants, etc.) which are not within the control of the manufacturer. Therefore the values should be regarded as indicative only.

EN 1092-1

Nominal size DN [mm]	Counter flanges & bolts		Max. allowable torque					
			Gasket: Filled PTFE / PTFE / PF29		Gasket: Graphite		O-ring	
	Rating	Size	Nm	ft-lb	Nm	ft-lb	Nm	ft-lb
2.5...10	PN 40	M12 x 141	-	-	-	-	32	24
15	PN 40	M12 x 141	-	-	-	-	36	27
25	PN 40	M12 x 141	22	16	32	24	-	-
40	PN 40	M16 x 176	47	35	66	49	-	-
50	PN 40	M16 x 203	58	43	82	60	-	-
80	PN 40	M16 x 261	48	35	69	51	-	-
100	PN 16	M16 x 303	75	55	106	78	-	-
100	PN 25	M20 x 176	94	69	133	98	-	-

ASME B 16.5

Nominal size [inch]	Counter flanges & bolts		Max. allowable torque					
			Gasket: Filled PTFE / PTFE / PF29		Gasket: Graphite		O-ring	
	Rating	Size	Nm	ft-lb	Nm	ft-lb	Nm	ft-lb
1/10...3/8"	150 lb	1/2"UNC x 142	-	-	-	-	35	26
1/2"	150 lb	1/2"UNC x 142	-	-	-	-	35	26
1"	150 lb	1/2"UNC x 142	24	18	33	24	-	-
1 1/2"	150 lb	1/2"UNC x 174	38	28	54	40	-	-
2"	150 lb	5/8"UNC x 215	58	43	83	61	-	-
3"	150 lb	5/8"UNC x 268	98	72	138	102	-	-
4"	150 lb	5/8"UNC x 318	75	55	108	80	-	-

4.1 Safety instructions

All work on the electrical connections may only be carried out with the power disconnected. Take note of the voltage data on the nameplate!

Observe the national regulations for electrical installations!

For devices used in hazardous areas, additional safety notes apply; please refer to the Ex documentation.

Observe without fail the local occupational health and safety regulations. Any work done on the electrical components of the measuring device may only be carried out by properly trained specialists.

Look at the device nameplate to ensure that the device is delivered according to your order. Check for the correct supply voltage printed on the nameplate.

4.2 Grounding

The device must be grounded in accordance with regulations in order to protect personnel against electric shocks.

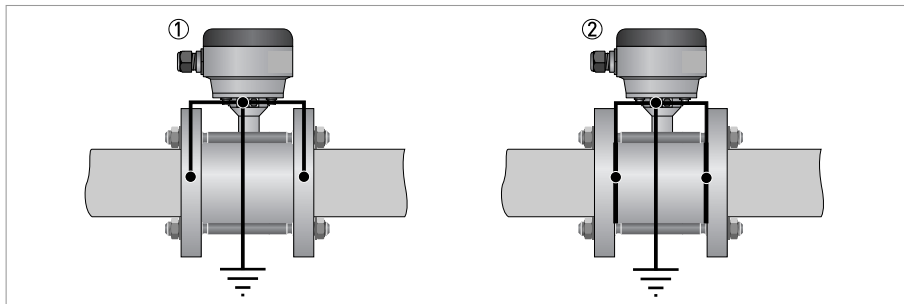

Figure 4-1: Grounding

- ① Metal pipelines, not internally coated. Grounding without grounding rings!
- ② Metal pipelines with internal coating and non-conductive pipelining. Grounding with grounding rings!

For diameter DN10/ 3/8" and DN15/ 1/2", grounding rings are integrated as standard in the flow sensor construction.

Grounding rings

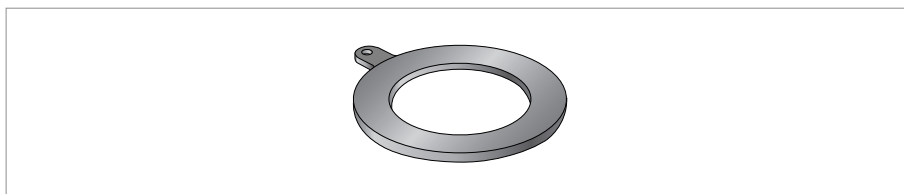

Figure 4-2: Grounding ring number 1

Grounding ring number 1 (optional for DN25...150 / 1...6"): Thickness: 3 mm / 0.1" (tantalum: 0.5 mm / 0.02")

4.3 Virtual reference option

Only in combination with the IFC 300 and IFC 400 signal converter (C, W and F version)

Benefits of virtual reference:

- Grounding rings or grounding electrodes can be omitted.
- Safety increases by reducing the number of potential leakage points.
- The installation of the flowmeters is much easier.
- Compliant with OIML-R49 and MID MI-001 certification (IFC 300).

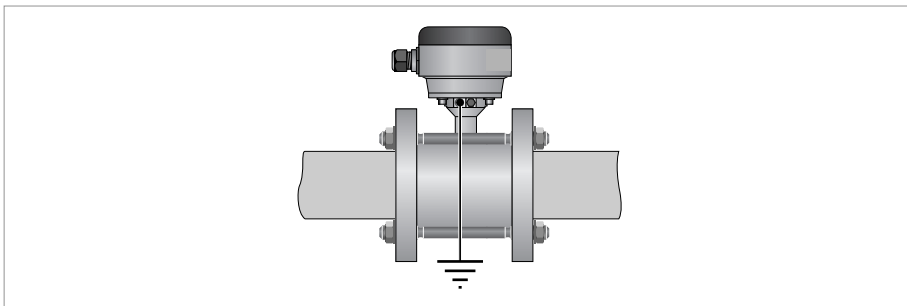
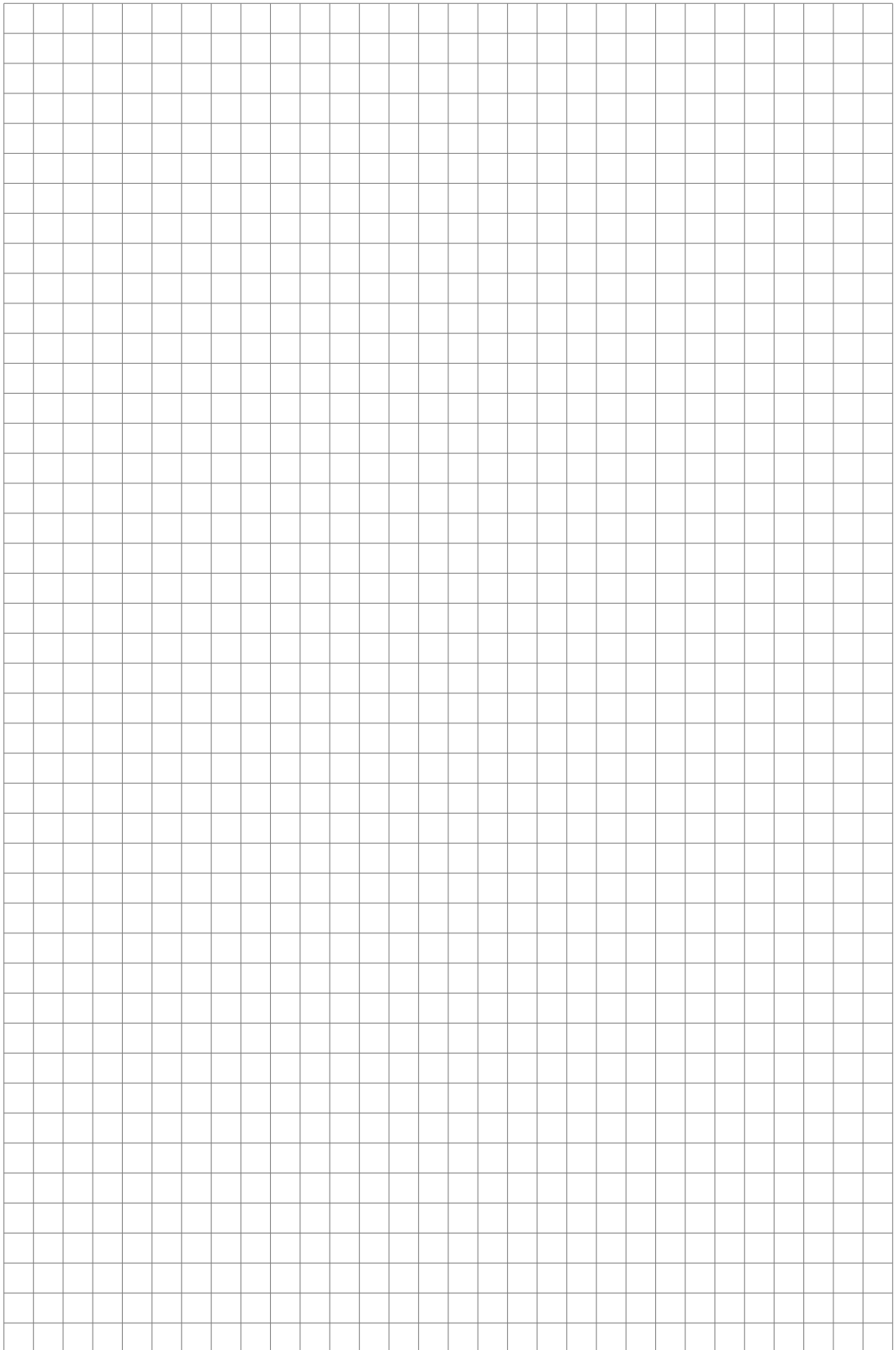

Figure 4-3: Virtual reference

Minimum requirements:

- Size: \geq DN10 / 3/8"
- Electrical conductivity: \geq 200 μ S/cm
- Signal cable: max. 50 m / 164 ft, type DS

Virtual reference cannot be activated when the IFC 400 is in the SIL mode.



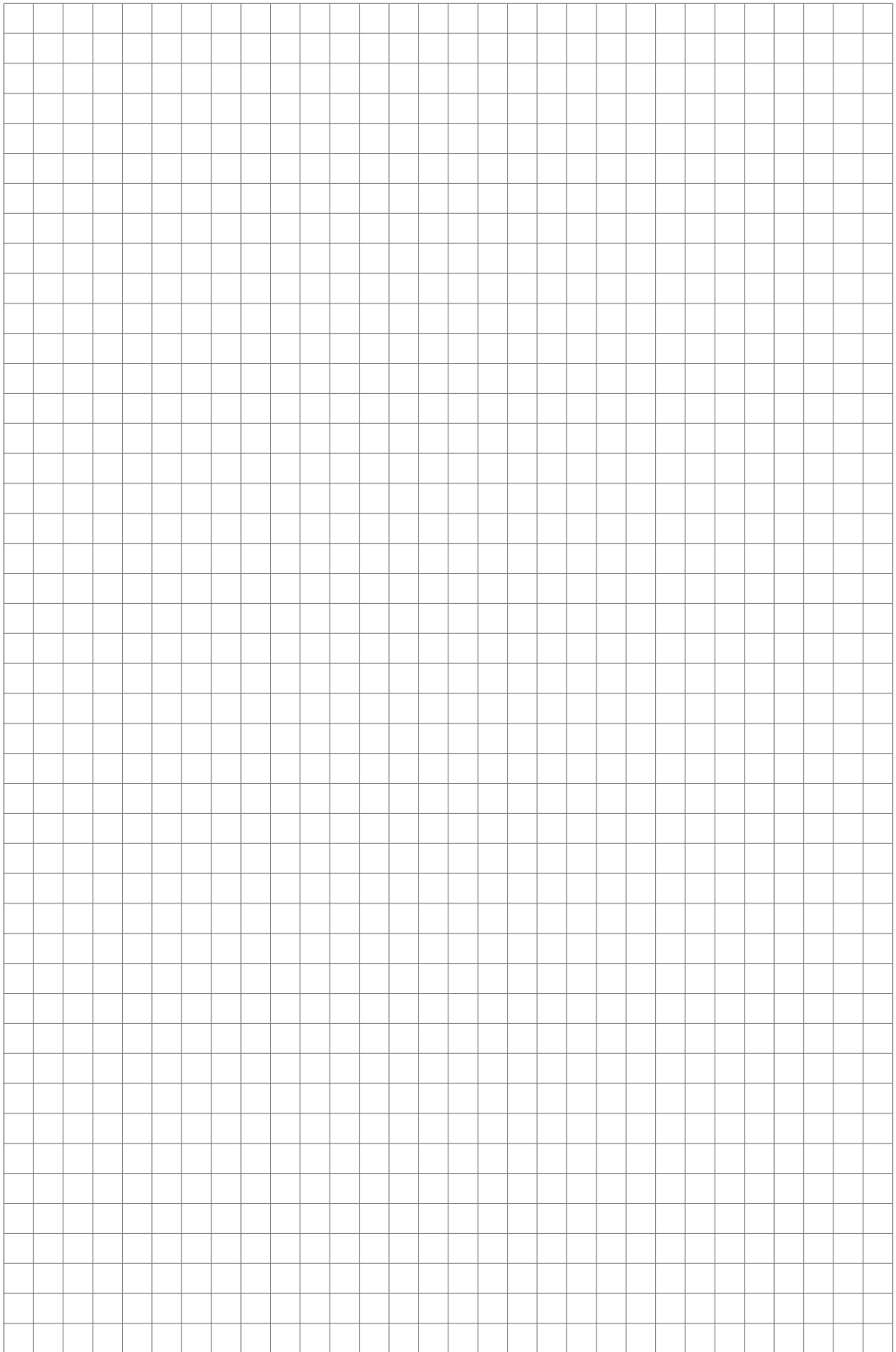

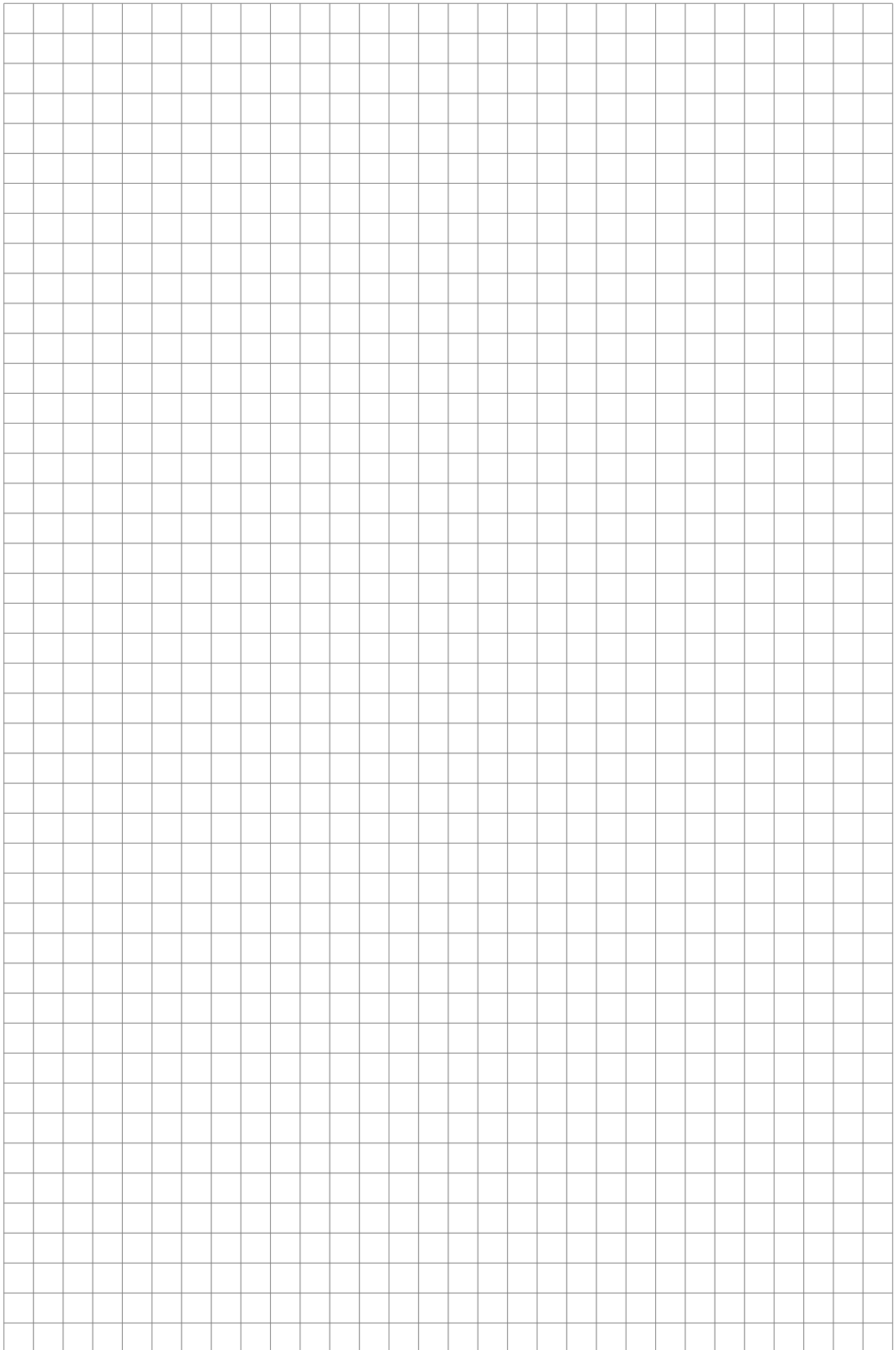

KROHNE – Products, Solutions and Services

- Process instrumentation for flow, level, temperature, pressure measurement and process analytics
- Flow metering, monitoring, wireless and remote metering solutions
- Engineering, commissioning, calibration, maintenance and training services

Head Office KROHNE Messtechnik GmbH
Ludwig-Krohne-Str. 5
47058 Duisburg (Germany)
Tel.: +49 203 301 0
Fax: +49 203 301 10389
info@krohne.de

The current list of all KROHNE contacts and addresses can be found at:
www.krohne.com

