

Micro Motion[®] Fork Density Meters

Direct insertion density meter installation

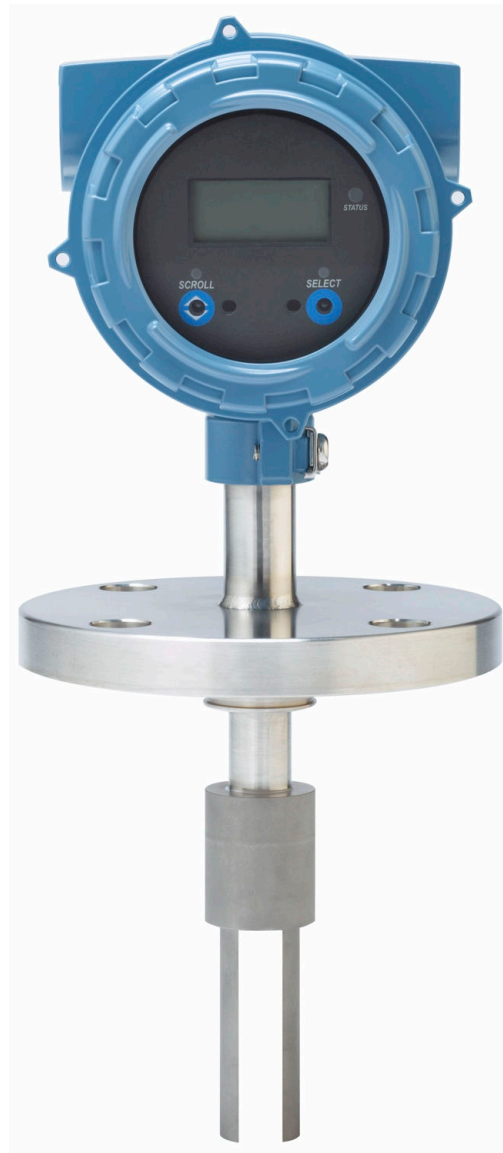

Safety messages

Safety messages are provided throughout this manual to protect personnel and equipment. Read each safety message carefully before proceeding to the next step.

Other information

Full product specifications can be found in the product data sheet. Troubleshooting information can be found in the configuration manual. Product data sheets and manuals are available from the Micro Motion web site at www.emerson.com.

Return policy

Follow Micro Motion procedures when returning equipment. These procedures ensure legal compliance with government transportation agencies and help provide a safe working environment for Micro Motion employees. Micro Motion will not accept your returned equipment if you fail to follow Micro Motion procedures.

Return procedures and forms are available on our web support site at www.emerson.com, or by phoning the Micro Motion Customer Service department.

Emerson Flow customer service

Email:

- Worldwide: flow.support@emerson.com
- Asia-Pacific: APflow.support@emerson.com

Telephone:

North and South America		Europe and Middle East		Asia Pacific	
United States	800-522-6277	U.K.	0870 240 1978	Australia	800 158 727
Canada	+1 303-527-5200	The Netherlands	+31 (0) 704 136 666	New Zealand	099 128 804
Mexico	+41 (0) 41 7686 111	France	0800 917 901	India	800 440 1468
Argentina	+54 11 4837 7000	Germany	0800 182 5347	Pakistan	888 550 2682
Brazil	+55 15 3413 8000	Italy	8008 77334	China	+86 21 2892 9000
		Central & Eastern	+41 (0) 41 7686 111	Japan	+81 3 5769 6803
		Russia/CIS	+7 495 981 9811	South Korea	+82 2 3438 4600
		Egypt	0800 000 0015	Singapore	+65 6 777 8211
		Oman	800 70101	Thailand	001 800 441 6426
		Qatar	431 0044	Malaysia	800 814 008
		Kuwait	663 299 01		
		South Africa	800 991 390		
		Saudi Arabia	800 844 9564		
		UAE	800 0444 0684		

Contents

Chapter 1	Before you begin.....	5
	1.1 About this manual.....	5
	1.2 Related documentation.....	5
Chapter 2	Planning.....	7
	2.1 Installation checklist.....	7
	2.2 Best practices.....	8
	2.3 Power requirements.....	8
	2.4 Other installation considerations.....	10
	2.5 Recommended installations for short-stem meters.....	12
	2.6 Perform a pre-installation meter check.....	14
Chapter 3	Mounting.....	17
	3.1 Free stream applications.....	17
	3.2 T-piece applications.....	21
	3.3 Mount with a flow-through chamber.....	26
	3.4 Mount in an open tank (long-stem meter).....	28
	3.5 Mount in a closed tank (long-stem meter).....	31
	3.6 Attach the PFA ring and circlip.....	35
	3.7 Rotate the electronics on the meter (optional).....	36
	3.8 Rotate the display on the transmitter (optional).....	37
Chapter 4	Wiring.....	39
	4.1 Terminals and wiring requirements.....	39
	4.2 Explosion-proof/flameproof or non-hazardous output wiring.....	39
	4.3 Processor wiring for remote-mount 2700 fieldbus.....	43
	4.4 Wiring to external devices (HART multidrop).....	48
	4.5 Wiring to signal converters and/or flow computers.....	49
Chapter 5	Grounding.....	51

1 Before you begin

1.1 About this manual

This manual provides information on planning, mounting, and wiring the FDM.

Important

This manual assumes that the following conditions apply:

- The device has been installed correctly and completely according to the instructions in the installation manual
 - The installation complies with all applicable safety requirements
 - The user is trained in government and corporate safety standards
-

1.2 Related documentation

You can find all product documentation on the product documentation DVD shipped with the product or at www.emerson.com.

See any of the following documents for more information:

- *Micro Motion Fork Density Meters (FDM) Product Data Sheet*
- *Micro Motion Fork Density Meters (FDM) Configuration and Use Manual*
- *Micro Motion Fork Density Meters (FDM) with FOUNDATION™ Fieldbus Configuration and Use Manual*
- *Micro Motion Model 1700 and 2700 Installation Manual*
- *Modbus Interface Tool*
- *Micro Motion Enhanced Density Application Manual*

2 Planning

2.1 Installation checklist

- Verify the contents of the product shipment to confirm that you have all parts and information necessary for the installation.
- Verify that the meter calibration-type code corresponds to the pipe size. If it does not, measurement accuracy may be reduced due to the boundary effect.
- Make sure that all electrical safety requirements are met for the environment in which the meter will be installed.
- Make sure that the local ambient and process temperatures and process pressure are within the limits of the meter.
- Make sure that the hazardous area specified on the approval tag is suitable for the environment in which the meter will be installed.
- Make sure that you will have adequate access to the meter for verification and maintenance.
- Verify that you have all equipment necessary for your installation. Depending on your application, you may be required to install additional parts for optimal performance of the meter.
- If your meter will be wired to a remote-mount 2700 FOUNDATION™ Fieldbus transmitter:
 - Refer to the instructions in this manual for preparing the 4-wire cable and wiring to the processor connections.
 - Refer to the instructions in the transmitter installation manual for mounting and wiring the 2700 fieldbus transmitter.
 - Consider the maximum cable length between the meter and transmitter. The maximum recommended distance between the two devices is 1,000 ft (305 m). Use Micro Motion cable.

2.2 Best practices

The following information can help you get the most from your meter.

- Handle the meter with care. Follow local practices for lifting or moving the meter.
- Perform a Known Density Verification (KDV) check of the meter prior to installing the meter.
- For the DLC-coated tines, always fit the protective cover over the tines when the meter is not in use. The tine coating is not resistant to impact damage.
- Always store and transport the meter in its original packaging. For the long-stem meters, be sure to include the transit cover secured by the grub screws.
- Do not use liquids that are incompatible with the materials of construction.
- Do not expose the meter to excessive vibration (greater than 0.5 g continuously). Vibration levels in excess of 0.5 g can affect the meter accuracy.
- For optimal performance of the meter, ensure that operating conditions correspond to the meter calibration-type code and boundary.
- Ensure that all piping connections conform to the local and national regulations and codes of practice.
- Properly tighten the transmitter housing cover after wiring to maintain ingress protection and hazardous area approvals.
- After installation, pressure test the meter and the associated pipework to 1½ times the maximum operating pressure.
- Install thermal insulation in the meter, the inlet, and the bypass-loop pipeline to maintain stable temperatures. The thermal insulation should cover the process connection.

2.3 Power requirements

Following are the DC power requirements to operate the meter:

- 24 VDC, 0.65 W typical, 1.1 W maximum
- Minimum recommended voltage: 21.6 VDC with 1,000 ft (305 m) of 24 AWG (0.205 mm²) power-supply cable
- At startup, power source must provide a minimum of 0.5 A of short-term current at a minimum of 19.6 V at the power-input terminals.

Power cable recommendations for explosion-proof/flameproof meters

Figure 2-1: Minimum wire gauge (AWG per foot or meter)

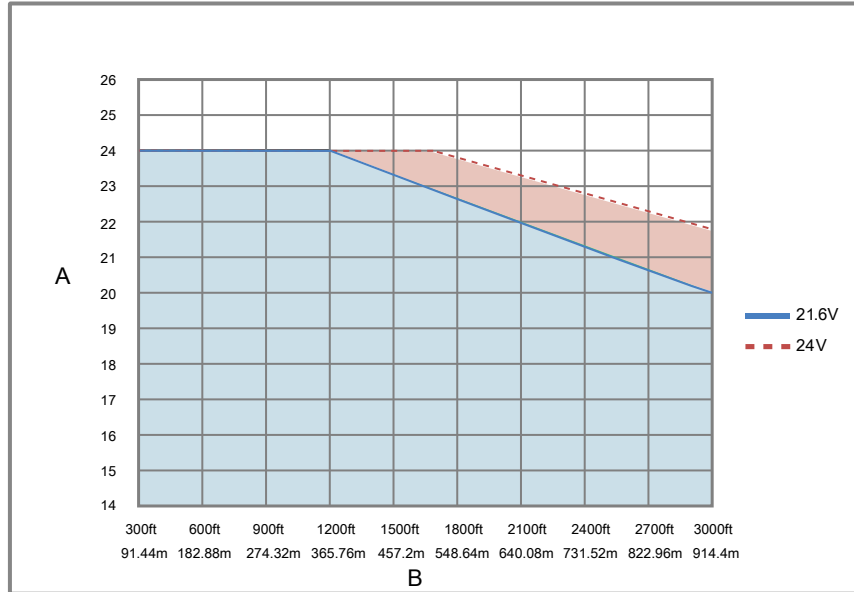

- A. AWG maximum
- B. Distance of installation

Figure 2-2: Minimum wire area (mm² per meter or foot)

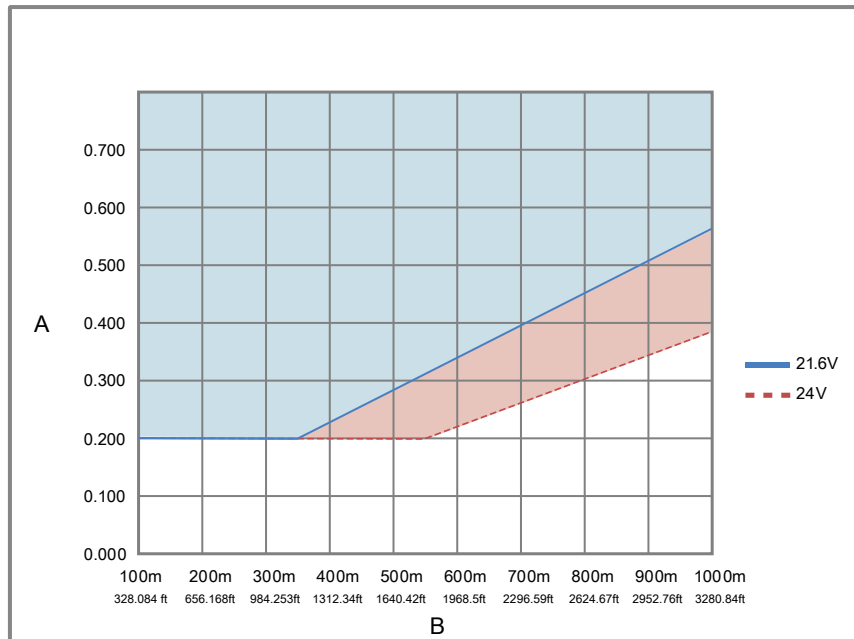

- A. Minimum wire area (mm²)
- B. Distance of installation

2.4 Other installation considerations

Numerous external factors can affect the meter's successful operation. To ensure that your system works correctly, consider the factors covered in this section when designing your installation.

2.4.1 Boundary effect

Boundary effect refers to the distortion in the wave forms in the process fluid that are caused by reflections from the pipe wall. If the pipe wall is within the meter's effective measurement region, the boundary effect produces measurement inaccuracy.

Figure 2-3: Region of measurement boundary or sensitivity (plan view)

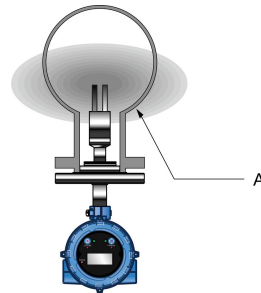

A. Sensitive, or effective, region

The factory calibration compensates for the boundary effect. The meter can be calibrated for free stream, 2 in (51 mm), 2.5 in (64 mm), or 3 in (76 mm) pipe. If the meter is installed in a pipe that does not match the calibration size, the compensation will be inaccurate, and process measurement will be inaccurate.

Verify that the meter was calibrated for the pipe size you plan to use.

2.4.2 Flow rates

Maintain constant flow rates and velocities that are within the limits specified for the meter. The fluid flow provides a steady heat flow into the meter installation, and the flow rate influences the self-cleaning of the meter tines, the dissipation of bubbles, and the solid contaminants around the meter.

If you install the meter in a bypass configuration (such as in a flow-through chamber), use a pressure drop across an orifice plate in the main process pipe, a pitot scoop arrangement, or a sample pump to maintain flow. When using a sample pump, place the pump upstream from the meter.

2.4.3 Entrained gas

Entrained gas, or gas pockets, can disrupt the measurement of a fluid. A brief disruption in the signal caused by transient gas pockets can be corrected in the meter configuration,

but you must avoid more frequent disruptions or serious gas entrainment to ensure accurate and reliable fluid measurement.

To minimize the possibility of entrained gas:

- Keep pipelines full of fluid at all times.
- Vent any gas prior to the meter installation location.
- Avoid sudden pressure drops or temperature changes that may cause dissolved gases to break out of the fluid.
- Maintain a back pressure on the system that is sufficient to prevent gas breakout.
- Maintain flow velocity at the sensor within the specified limits.

2.4.4 Slurry measurement

To ensure quality measurement when solids are present:

- Avoid sudden changes of the fluid velocity that may cause sedimentation.
- Install the meter far enough downstream from any pipework configuration that may cause centrifuging of solids (such as at a pipe bend).
- Maintain flow velocity at the meter installation that is within the specified limits.

2.4.5 Temperature gradients and insulation

For high-viscosity fluids, minimize any temperature gradients in the fluid, and in the piping and fittings immediately upstream and downstream of the meter. Minimizing temperature gradients reduces the effect of viscosity changes. Use the following guidelines to reduce the thermal effects to your meter installation:

- Always insulate the meter and surrounding pipework thoroughly.
 - Avoid insulating the transmitter housing.
 - Use rock wool or any equivalent heat jacket material that is at least 1 in (25 mm) thick, but preferably 2 in (51 mm) thick.
 - Enclose insulation in a sealed protective casing to prevent moisture ingress, air circulation, and crushing of the insulation.
 - For flow-through chamber installations, use the special insulation jacket provided by Micro Motion.
- Avoid direct heat or cold on the meter or on the associated upstream or downstream pipe work that is likely to create temperature gradients.
- If it is necessary to protect against cooling because of flow loss, you can apply electrical-trace heating. If you use electrical-trace heating, use a thermostat that operates below the minimum operating temperature of the system.

2.4.6 Pressure and temperature limits for process connections

You must ensure that the pressure and temperature limits for the meter are not exceeded – if necessary, by the use of suitable safety accessories. Pressure and temperature ratings

for the meter connections are in accordance with the relevant flange standard. Check the latest standards for your connections.

For the pressure and temperature limits for Zirconium 702 process connections, see [Table 2-1](#).

Table 2-1: Pressure/temperature ratings for Zirconium 702 process connections

Process flange type	Pressure and temperature ratings			
	100 °F (37.8 °C)	199.9 °F (93.28 °C)	299.8 °F (148.78 °C)	392 °F (200.0 °C)
2 in (51 mm) ANSI 150	226.3 psi (15.603 bar)	197.3 psi (13.603 bar)	159.5 psi (10.997 bar)	110.2 psi (7.598 bar)
2 in (51 mm) ANSI 300	588.9 psi (40.603 bar)	513.4 psi (35.398 bar)	417.7 psi (28.799 bar)	336.5 psi (23.201 bar)
DN50 PN16	229.2 psi (15.803 bar)	175.5 psi (12.100 bar)	137.8 psi (9.501 bar)	1107.3 psi (7.398 bar)
DN50 PN40	571.5 psi (39.404 bar)	439.5 psi (30.302 bar)	342.3 psi (23.601 bar)	266.9 psi (18.402 bar)

2.5 Recommended installations for short-stem meters

Micro Motion recommends three standard installations for the short-stem meter to alleviate any need for onsite calibration. All meters are factory calibrated for these types of installations and take into consideration the potential boundary effect of each installation.

Free stream applications

Flow rate	0.3 to 0.5 m/s at the meter
Viscosity	Up to 20,000 cP
Temperature	<ul style="list-style-type: none"> -58 °F (-50.0 °C) to 392 °F (200.0 °C) -40 °F (-40.0 °C) to 392 °F (200.0 °C) in hazardous areas
Main flow pipe size	<ul style="list-style-type: none"> Horizontal pipe: minimum diameter, 4 in (102 mm) Vertical pipe: minimum diameter, 6 in (152 mm)
Advantages	<ul style="list-style-type: none"> Simple installation in large bore pipes Ideal for clean fluids and non-waxing oils Suitable for line density measurement and simple referrals
Recommendations	Do not use with: <ul style="list-style-type: none"> Low or unstable flow rates For small bore pipes

T-piece applications

Flow rate	0.5 to 3 m/s at main pipe wall By increasing the insertion depth of the tines into the T-piece, the flow velocity can be increased to 5 m/s for clean fluids. For slurry applications, the maximum flow velocity should be no greater than 4 m/s.
Viscosity	<ul style="list-style-type: none"> For the 2 in (51 mm) (DN50) T-piece, viscosity limit is 100 cP (200 cP in some cases). For the 3 in (76 mm) (DN80) T-piece, the viscosity limit is 1000 cP.
Temperature	-58 °F (-50.0 °C) to 392 °F (200.0 °C)
Main flow pipe size	Minimum diameter, 2 in (51 mm)
Advantages	<ul style="list-style-type: none"> Simple installation in large bore pipes Ideal for clean fluids and non-waxing oils 3 in (76 mm) T-Piece installation ideal for high percentage slurry applications Suitable for line density measurement and simple referrals
Recommendations	Do not use with: <ul style="list-style-type: none"> Low or unstable flow rates Where step changes in viscosity can occur For small bore pipes Where temperature effects are significant

Flow-through chamber applications

Flow rate	<ul style="list-style-type: none"> 5–40 l/min for 2 in (51 mm) Schedule 40 calibration bore section (1.5 - 10.5 gal/min) 5–300 l/min for 3 in (76 mm) Schedule 80 calibration bore section (1.5 - 80 gal/min)
Viscosity	<ul style="list-style-type: none"> For the 2 in (51 mm) (DN50) Flow Chamber, viscosity limit is 100 cP (200 cP in some cases). For the 3 in (76 mm) (DN80) Flow Chamber, the viscosity limit is 1000 cP.
Temperature	-58 °F (-50.0 °C) to 392 °F (200.0 °C)
Main flow pipe size	Suitable for all sizes, if mounted in a bypass (slipstream) configuration

Advantages	<ul style="list-style-type: none">• Adaptable installation to any diameter main pipe and for tank applications• Ideal for flow and temperature conditioning• Suitable for complex referrals and for use with heat exchangers• Suitable for step changes in viscosity• Fast response• Ideal for analyzer cubicles
Recommendations	<ul style="list-style-type: none">• Do not use with uncontrolled flow rates.• Careful system design is required to ensure representative measurement.• Frequently requires the use of a pump.

2.6 Perform a pre-installation meter check

Check the meter prior to installation to confirm that no damage occurred to the meter during shipment.

Procedure

1. Remove the meter from the box.



CAUTION

Handle the meter with care. Follow all corporate and government safety regulations for lifting and moving the meter.

2. Visually inspect the meter for any physical damage.
If you notice any physical damage to the meter, immediately contact customer support at flow.support@emerson.com.
3. Position and secure the meter in a vertical position with the flow arrow pointing upward.
4. Connect the power wiring, and power up the meter.
Remove the back transmitter housing cover to access the **PWR** terminals.

Figure 2-4: Power supply wiring terminals

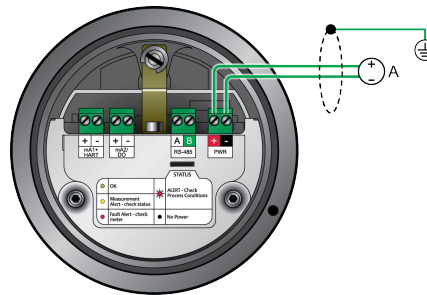

A. 24 VDC

5. Perform a Known Density Verification (KDV) check.
Use the Known Density Verification procedure to match the current meter calibration with the factory calibration. If the meter passes the test, then it has not drifted or changed during shipment.

For more information on performing a KDV check, see the configuration and use manual that shipped with the product.

3 Mounting

If the meter's flow velocity is:

- Below 0.3 to 0.5 m/s, install the meter as a free-stream application.
- Above 0.3 to 0.5 m/s, install the meter as either a T-piece or flow chamber application. As an alternative, if the pipework can be expanded to reduce the flow velocity to between 0.3 to 0.5 m/s, install a free stream application.

3.1 Free stream applications

3.1.1 Mount in free-stream application (flanged fitting)

Prerequisites

- Free-stream (flanged) installations are recommended for processes with the following conditions:

Flow	0.3 to 0.5 m/s at the meter
Viscosity	<ul style="list-style-type: none"> – Up to 500 cP with long tines – Up to 20,000 cP with short tines
Temperature	-58 °F (-50.0 °C) to 392 °F (200 °C)
	-40 °F (-40.0 °C) to 392 °F (200 °C) in hazardous areas

Note

If temperature variations are a critical factor in your process, the reduced thermal mass of the taper-lock fitting of the weldolet can track changes in temperature more efficiently.

- Before fitting the weldolet, you must bore a 2.1 in (53 mm) diameter opening in the pipeline to accept the meter. You must weld the weldolet to the pipeline concentrically with the pre-bored hole.

Procedure

Use [Figure 3-1](#) to mount a meter in a free-stream flanged fitting installation.

- Insert meter tines directly into the fluid flow.
- For both vertical and horizontal pipes, always install the meter on the side of the pipe. For a horizontal pipe, never mount the meter on the top of the pipe.

Important

During installation, always position the meter so that the gap between the tines is vertical. This position helps prevent the trapping of bubbles or solids on the meter – allowing the solids to sink and the bubbles to rise. You can use the scribe mark on the spigot (located between the flange and transmitter) as a reference for the tine orientation. Always orient the meter so the scribe mark is at either the 12 o'clock or 6 o'clock position.

The gap between the fork tines must always be vertical so that:

- Solids drop down
- Entrained gas will go up



Figure 3-1: Free-stream flanged fitting meter installation

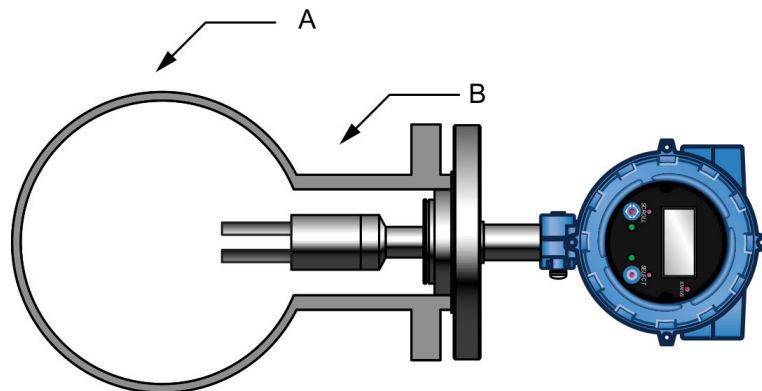

- A. Use a 4 in (102 mm) pipe for horizontal installations; a 6 in (152 mm) pipe for vertical installations.
- B. Size the recess mount so that the meter tines are inserted fully into the liquid [approximately 2.75 in (70 mm)].

3.1.2 Mount in free-stream application (pipe expanders)

Use the following procedure to mount pipe expanders.

Pipe expanders:

- Increase the diameter of the process pipe to reduce the flow velocity
- Provide a quick response to density changes
- Provide self-cleaning vibrating tines

The following table determines what type of pipe expander to use.

Option	Best usage
Vertical pipe with a concentric reducer	Suitable for all liquids and slurries.
Horizontal pipe with concentric reducer	Suitable for clean liquids. Do not use for slurry applications, as solids can build up on the bottom of the pipe.
Horizontal pipe with eccentric reducer	Suitable fo slurry applications.

Procedure

Expand the main process pipe using any of the following options.

Vertical pipe with concentric reducer	Figure 3-2
Horizontal pipe with concentric reducer	Figure 3-3
Horizontal pipe with eccentric reducer	Figure 3-4

Figure 3-2: Option 1: Vertical pipe with a concentric reducer

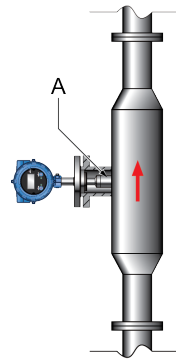

A. FDM directly inserted into the flow

Figure 3-3: Option 2: Horizontal pipe with concentric reducers

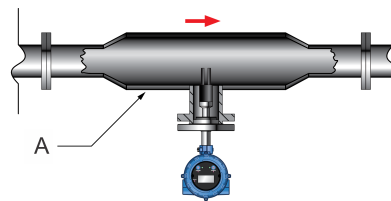

A. Top view of horizontal pipeline

Figure 3-4: Option 3: Horizontal pipe with eccentric reducers

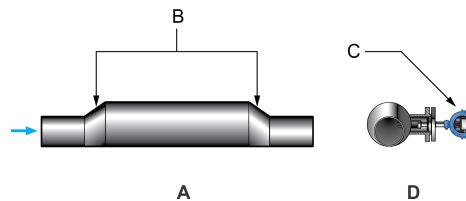

- A. Side view of horizontal pipe (meter is on the opposite side)
- B. Eccentric expanders/reducers
- C. Meter inserted into the flow in an expanded pipe
- D. Inside view of pipe and meter

If you use eccentric reducers, the piping must maintain 20 in (508 mm) of upstream straight run (both sides for bidirectional flow applications) to avoid jet effect and a resultant “spray” on the fork tines.

3.1.3 Mount in free-stream application (weldolet fitting)

The weldolet for free-stream installations has a 1.5 in (38 mm) taper lock fitting and is supplied to be welded on 4 in (102 mm), 6 in (152 mm), 8 in (203 mm), or 10 in (254 mm) pipelines. A weldolet installation ensures that the tines of the meter are oriented correctly and are fully inserted into the fluid stream.

Prerequisites

- Free-stream (weldolet) installations are recommended for processes with the following conditions:

Flow	0.3 to 0.5 m/s at the meter
Viscosity	<ul style="list-style-type: none"> — Up to 500 cP with long tines — Up to 20,000 cP with short tines
Temperature	<ul style="list-style-type: none"> -58 °F (-50.0 °C) to 392 °F (200 °C) -40 °F (-40.0 °C) to 392 °F (200 °C) in hazardous areas

Note

If temperature variations are a critical factor in your process, the reduced thermal mass of the taper-lock fitting of the weldolet can track changes in temperature more efficiently.

- Before fitting the weldolet, you must bore a 2.1 in (53 mm) diameter opening in the pipeline to accept the meter. You must weld the weldolet to the pipeline concentrically with the pre-bored hole.

Procedure

See [Figure 3-5](#) for information on installing the meter (with a weldolet fitting) in a free-stream application.

- Insert meter tines directly into the fluid flow.
- For both vertical and horizontal pipes, always install the meter on the side of the pipe. For a horizontal pipe, never mount the meter on the top of the pipe.

Important

During installation, always position the meter so that the gap between the tines is vertical. This position helps prevent the trapping of bubbles or solids on the meter – allowing the solids to sink and the bubbles to rise. You can use the scribe mark on the spigot (located between the flange and transmitter) as a reference for the tine orientation. Always orient the meter so the scribe mark is at either the 12 o’clock or 6 o’clock position.

The gap between the fork tines must always be vertical so that:

- Solids drop down
- Entrained gas will go up



Figure 3-5: Free-stream (weldolet fitting) meter installation

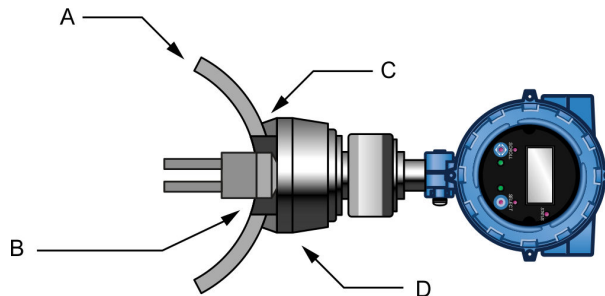

- A. 4 in (102 mm) pipe for horizontal installations; 6 in (152 mm) pipe for vertical installations
- B. 2.1 in (53 mm) meter opening in pipeline
- C. Weld
- D. Free-stream weldolet (purchased to fit pipe diameter)

3.2 T-piece applications

3.2.1 Mount with a 2 in (51 mm) T-piece (flanged fitting)

Prerequisites

- 2 in (51 mm) T-piece (flanged) installations are recommended for processes with the following conditions:

Flow	0.5 to 5 m/s (at the pipe wall)
Viscosity	Up to 100 cP, or 250 cP under some conditions
Temperature	-58 °F (-50.0 °C) to 392 °F (200 °C) -40 °F (-40.0 °C) to 392 °F (200 °C)

Note

- Flow velocity at the pipe wall and fluid viscosity must be within the limits shown to ensure that the fluid within the pocket is refreshed in a timely manner. This installation will not respond as rapidly as the free-stream installation to step changes in viscosity.
- The thermal mass of the flanges may affect the response time of the meter to temperature changes.

- Attach the PFA ring and circlip to the underside of the meter flange before installing the meter in your application (see [Attach the PFA ring and circlip](#)).

Note

If you are using a Zirconium meter, this meter uses a self-locking PFA ring and does not require a circlip.

Procedure

1. See [Figure 3-6](#) for information on installing the meter with a flanged fitting in a 2 in (51 mm) T-piece.

Figure 3-6: T-piece (flanged fitting) meter installation

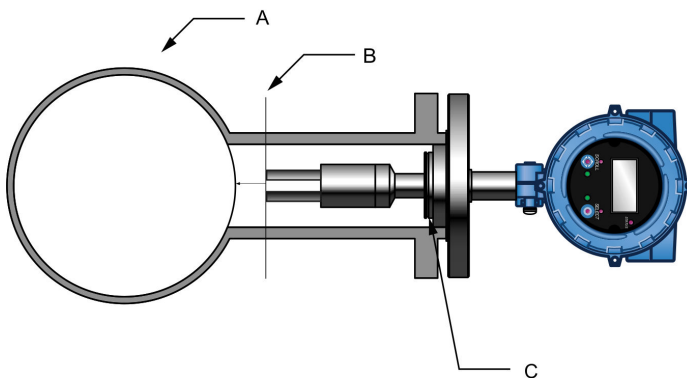

- A. 2 in (51 mm) pipe or larger for horizontal or vertical installations
- B. Distance of meter tines from main pipe wall is determined by the maximum flow rate of the process.
- C. PFA ring and circlip (not required for a self-locking PFA ring)

Tip

For hygienic applications, a normal 2 in (51 mm) hygienic tube is too thin for this application; (it can vibrate in sympathy with the fork, causing measurement errors). Use a 3 in (76 mm) hygienic tube and fittings instead, or fabricate hygienic fittings with the same wall thickness and internal diameter as those shown in the diagram above.

- Insert meter tines directly into the fluid flow.
- For both vertical and horizontal pipes, always install the meter on the side of the pipe. For a horizontal pipe, never mount the meter on the top of the pipe.

Important

During installation, always position the meter so that the gap between the tines is vertical. This position helps prevent the trapping of bubbles or solids on the meter – allowing the solids to sink and the bubbles to rise. You can use the scribe mark on the spigot (located between the flange and transmitter) as a reference for the tine orientation. Always orient the meter so the scribe mark is at either the 12 o'clock or 6 o'clock position.

The gap between the fork tines must always be vertical so that:

- Solids drop down

- Entrained gas will go up



2. Size the T-piece so that the meter tines are retracted 1 in (25 mm) from the main pipe wall. For higher flow rates, increase this by 0.4 in (10 mm) for every 1 m/s increase in the main flow rate.

Figure 3-7: Pipe wall installation

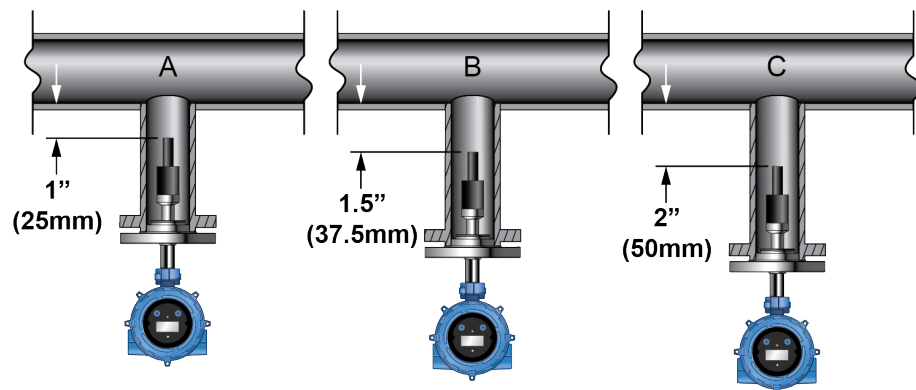

- A. Velocity ≤ 10 ft/sec (3 m/s)
 B. $10 < \text{velocity} \leq 13$ ft/sec (4 m/s)
 C. $13 < \text{velocity} \leq 16$ ft/sec (5 m/s)

3.2.2 Mount with a 3 in (76 mm) T-piece (flanged fitting)

Mount the FDM in a T-piece pipeline for slurry measurement applications. The T-piece should be 3 in (76 mm) (DN80) and mounted at an angle to ensure that it will self-drain. Flow velocity as low as 1.0m/s is acceptable, and preferred velocity is 3m/sec. Care should be taken at flow velocities of 5m/sec, as there is an increased risk of the T-piece clogging. Additional cleaning may be required.

Prerequisites

- 3 in (76 mm) T-piece (flanged) installations are recommended for processes with the following conditions:

Flow	0.5 to 5 m/s (at the pipe wall)
Viscosity	Up to 100 cP, or 1000 cP if the insertion distance does not exceed 1 in (25 mm).
Temperature	-58 °F (-50.0 °C) to 392 °F (200 °C) -40 °F (-40.0 °C) to 392 °F (200 °C) in hazardous areas

Note

- Flow velocity at the pipe wall and fluid viscosity must be within the limits shown to ensure that the fluid within the pocket is refreshed in a timely manner. This installation will not respond as rapidly as the free-stream installation to step changes in viscosity.
- The thermal mass of the flanges may affect the response time of the meter to temperature changes.

-
- Attach the PFA ring and circlip to the underside of the meter flange before installing the meter in your application (see [Attach the PFA ring and circlip](#)).

Note

If you are using a Zirconium meter, this meter uses a self-locking PFA ring and does not require a circlip.

Procedure

See [Figure 3-8](#) or [Figure 3-9](#) for information on installing the meter with a flanged fitting in a 3 in (76 mm) T-piece.

Figure 3-8: 3 in (76 mm) T-piece installation: horizontal pipe

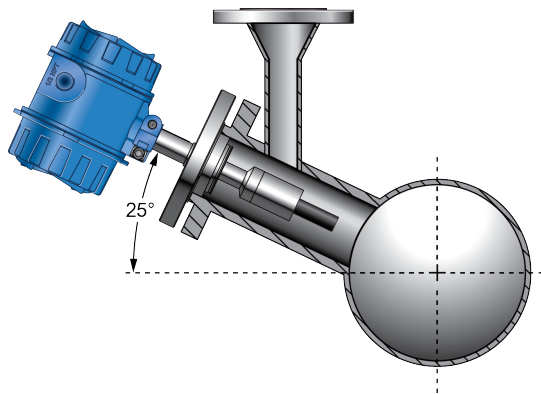

Insert a purge/drain connection on the upper part of the T-piece. You can use the purge connection to flush the pipe if necessary.

Figure 3-9: 3 in (76 mm) T-piece installation: vertical pipe

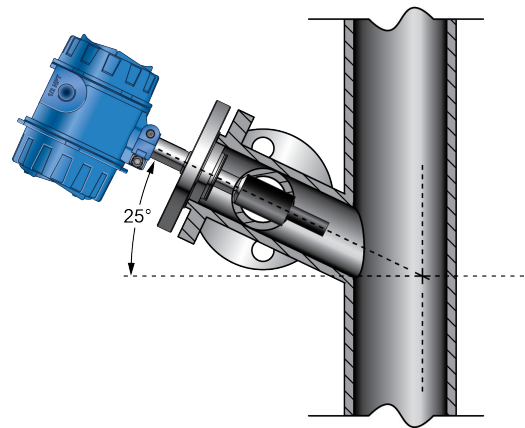

Insert a purge/drain connection on the side of the T-piece. You can use the purge connection to flush the pipe if necessary.

3.2.3 Mount with a T-piece (weldolet fitting)

The weldolet for T-piece installations has a 1.5 in (38 mm) taper lock fitting and is supplied to be welded on 4 in (102 mm), 6 in (152 mm), 8 in (203 mm) or 10 in (254 mm) pipelines. A weldolet installation ensures that the tines of the meter are oriented correctly and are fully inserted into the fluid stream.

Prerequisites

- T-piece (weldolet) installations are recommended for processes with the following conditions:

Flow	0.5 to 3 m/s (at the pipe wall)
Viscosity	Up to 100 cP, or 250 cP under some conditions
Temperature	-58 °F (-50.0 °C) to 392 °F (200 °C)

Note

- Flow velocity at the pipe wall and fluid viscosity must be within the limits shown to ensure that the fluid within the pocket is constantly refreshed. This installation will not respond as rapidly as the free-stream installation to step changes in viscosity.
 - If temperature variations are a critical factor in your process, the reduced thermal mass of the taper-lock fitting of the weldolet renders it more able to track rapid changes in temperature
- Before fitting the weldolet, you must bore a 2.1 in (53 mm) diameter opening in the pipeline to accept the meter. You must weld the weldolet to the pipeline concentrically with the pre-bored hole.

Procedure

See [Figure 3-5](#) for information on installing the meter (with a weldolet fitting) in a T-piece. Size the T-piece so that the meter tines are retracted 1 in (25 mm) from the main pipe wall. For higher flow rates, increase this by 0.39 in (10 mm) for every 1 m/s increase in the main flow rate.

Important

During installation, always position the meter so that the gap between the tines is vertical. This position helps prevent the trapping of bubbles or solids on the meter – allowing the solids to sink and the bubbles to rise. You can use the scribe mark on the spigot (located between the flange and transmitter) as a reference for the tine orientation. Always orient the meter so the scribe mark is at either the 12 o'clock or 6 o'clock position. The gap between the fork tines must always be vertical so that:

- Solids drop down
- Entrained gas will go up



Figure 3-10: T-piece (weldolet fitting) meter installation

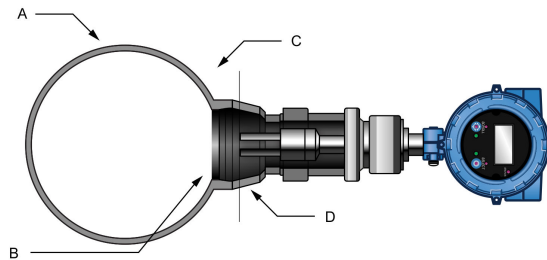

- A. 4 in (102 mm) pipe or larger for horizontal or vertical installations
- B. 2.1 in (53 mm) meter opening in pipeline
- C. Distance of meter tines from main pipe wall is determined by the maximum flow rate of the process
- D. Weldolet (purchased to fit pipe diameter)

3.3 Mount with a flow-through chamber

Flow-through chambers are manufactured by Micro Motion, and are available with either of the following:

- Welded ends or compression fittings that connect into the process pipelines
- 1 in (25 mm), 2 in (51 mm), or 3 in (76 mm) inlet and outlet pipes

Important

Do not alter the length of the inlet and outlet pipes. Pipe alterations can adversely affect the fitting temperature response and stability.

Prerequisites

Verify the following conditions:

Flow	<ul style="list-style-type: none"> 5–40 l/min for 2 in (51 mm) Schedule 40 calibration bore section (1.5 - 10.5 gal/min) 5–300 l/min for 3 in (76 mm) Schedule 80 calibration bore section (1.5 - 80 gal/min)
Viscosity	Up to 1000 cP
Temperature	-58 °F (-50.0 °C) to 392 °F (200 °C)
	-40 °F (-40.0 °C) to 392 °F (200 °C) in hazardous areas
Pressure	1,015.26 psi (70 bar) @ 399 °F (203.9 °C), subject to process connections

Important

- To ensure that the fluid within the pocket is refreshed in a timely manner, verify that flow velocity at the pipe wall and fluid viscosity are within the limits described in this table.
- The thermal mass of the flanges may affect the response time of the meter to temperature changes.

Procedure

See [Figure 3-11](#) for an example installation of a meter in a flow-through chamber.

Figure 3-11: Flow-through chamber meter installation

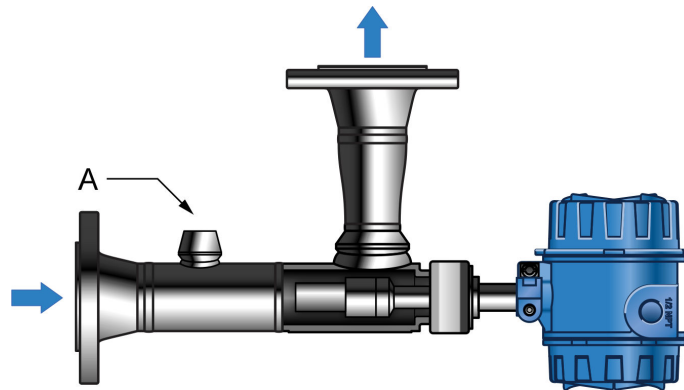

A. Optional temperature port

Note

- This flow-through chamber is a direct-insertion type chamber that does not have a thermowell, and uses a 0.75 in (19 mm) Swagelok connection.
- The three compression fittings on the flow pockets (0.5 in (13 mm) drain, 0.75 in (19 mm) temperature probe, and 1.5 in (38 mm) mounting nut for the meter) are rated to above the working pressure of the flow pocket. The fittings may be Swagelok or Parker.

3.4 Mount in an open tank (long-stem meter)

! CAUTION

Only the safe area version of the long-stem meter can be mounted in an open tank.

Prerequisites

Verify the following conditions:

Flow	0.3 to 0.5 m/s (at the meter) Important If an agitator/stirrer is fitted inside the tank, then the flow velocity inside the tank could be higher than 0.5m/s if the meter is mounted close to the side wall. Mounting the meter closer the center of the tank helps reduce the flow velocity seen by the meter.
Viscosity	<ul style="list-style-type: none"> • Up to 500 cP (with long tines) • Up to 20,000 cP (with short tines)
Fluid temperature	-40 °F (-40.0 °C) to 302 °F (150 °C)

Ambient temperature	-40 °F (-40.0 °C) to 149 °F (65 °C)
	Important For an open tank installation, consider the ambient temperature above the tank. Although the meter can operate at 302 °F (150 °C), with an open tank installation, the maximum ambient temperature above the tank is limited to 149 °F (65 °C).

Procedure

1. Clamp the long-stem meter to a structure, positioning the clamp to determine the insertion depth of the meter.

Figure 3-12: Open-tank meter installation (long stem)

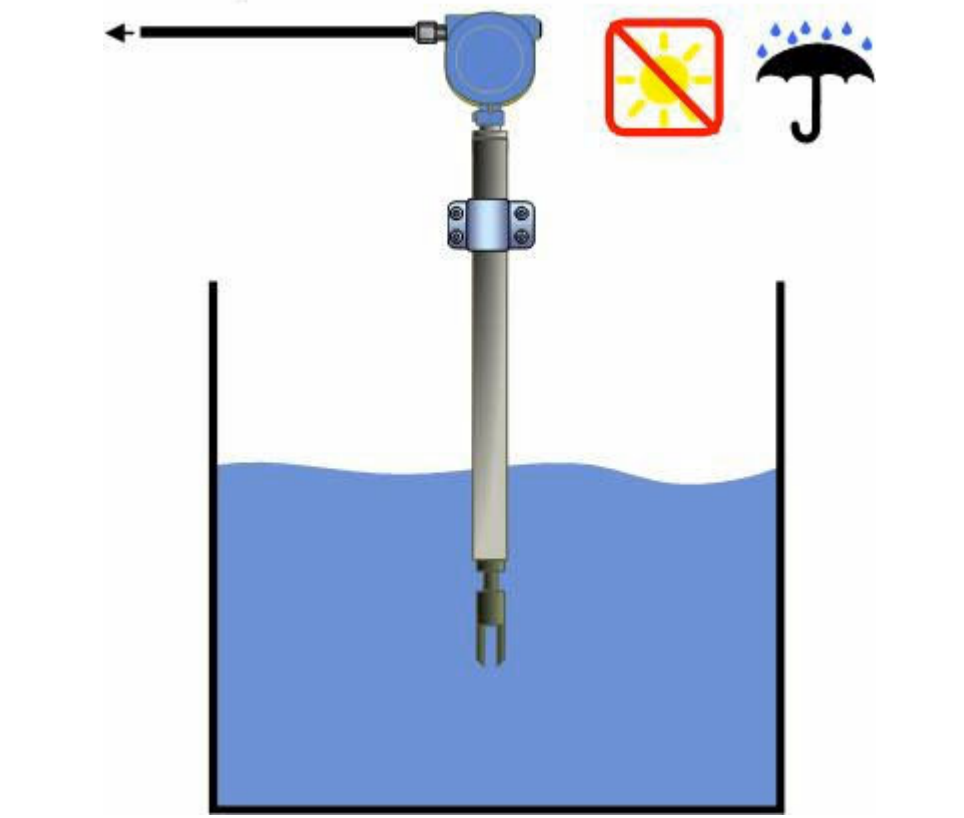

2. Confirm the meter tines are away from the tank wall.

Figure 3-13: Meter placement (away from tank wall)

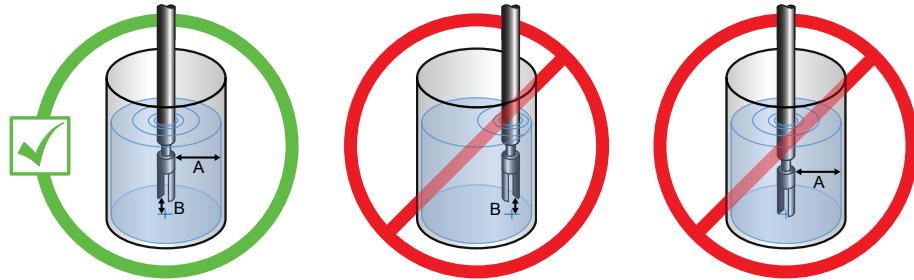

A. 2 in (51 mm)
B. 7.87 in (200 mm)

3. Confirm the meter tines are immersed in fluid.

Figure 3-14: Meter placement (immersed in fluid)

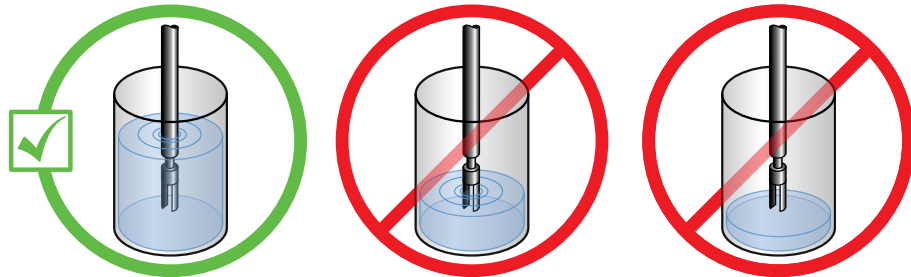

4. Confirm the meter tines are placed away from objects and disturbed flow.

Figure 3-15: Meter placement (distance from objects and disturbed flow)

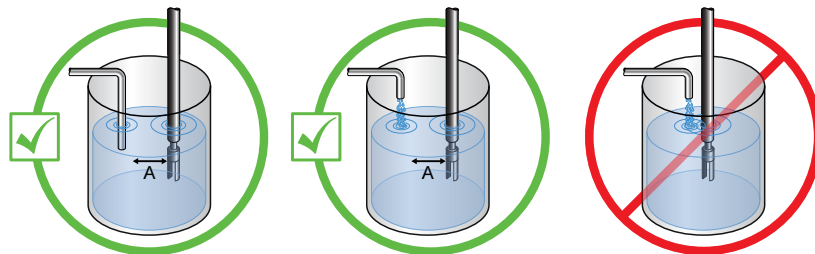

A. 7.87 in (200 mm)

5. If flow exists, confirm the meter tines are aligned so that the flow is directed towards or through the gap between the tines.

Figure 3-16: Meter placement (flow direction through tine gap)

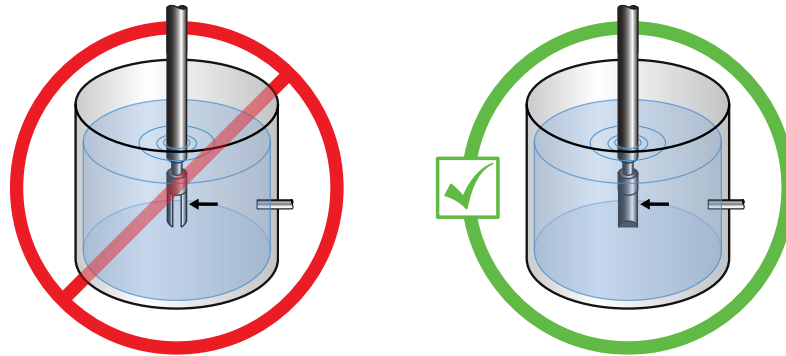

6. Confirm the meter tines are kept away from deposit buildup.

Figure 3-17: Meter placement (away from deposit buildup)

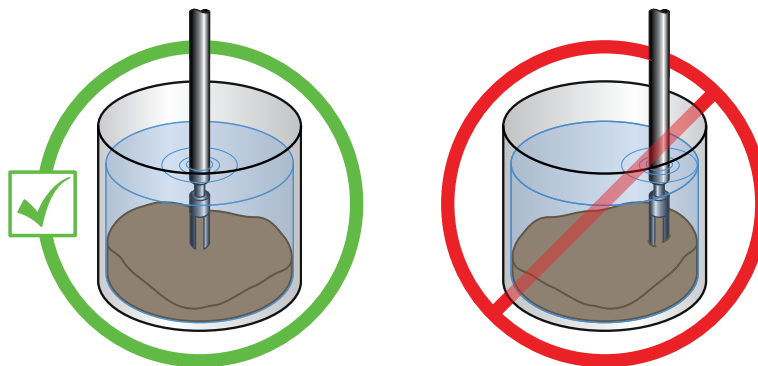

3.5 Mount in a closed tank (long-stem meter)

Prerequisites

Verify the following conditions:

Flow	0.3 to 0.5 m/s (at the meter)
	<p>Important</p> <p>If an agitator/stirrer is fitted inside the tank, then the flow velocity inside the tank could be higher than 0.5m/s if the meter is mounted close to the side wall. Mounting the meter closer the center of the tank helps reduce the flow velocity seen by the meter.</p>

Viscosity	<ul style="list-style-type: none">• Up to 500 cP (with long tines)• Up to 20,000 cP (with short tines)
Fluid temperature	-40 °F (-40.0 °C) to 302 °F (150 °C)
Ambient temperature	-40 °F (-40.0 °C) to 149 °F (65 °C) Important For an open tank installation, consider the ambient temperature above the tank. Although the meter can operate at 302 °F (150 °C), with an open tank installation, the maximum ambient temperature above the tank is limited to 149 °F (65 °C).

Procedure

1. Attach the long-stem meter using the fitted flange attachment that's shipped with the product.

Figure 3-18: Closed-tank installation (fitted flange attachment)

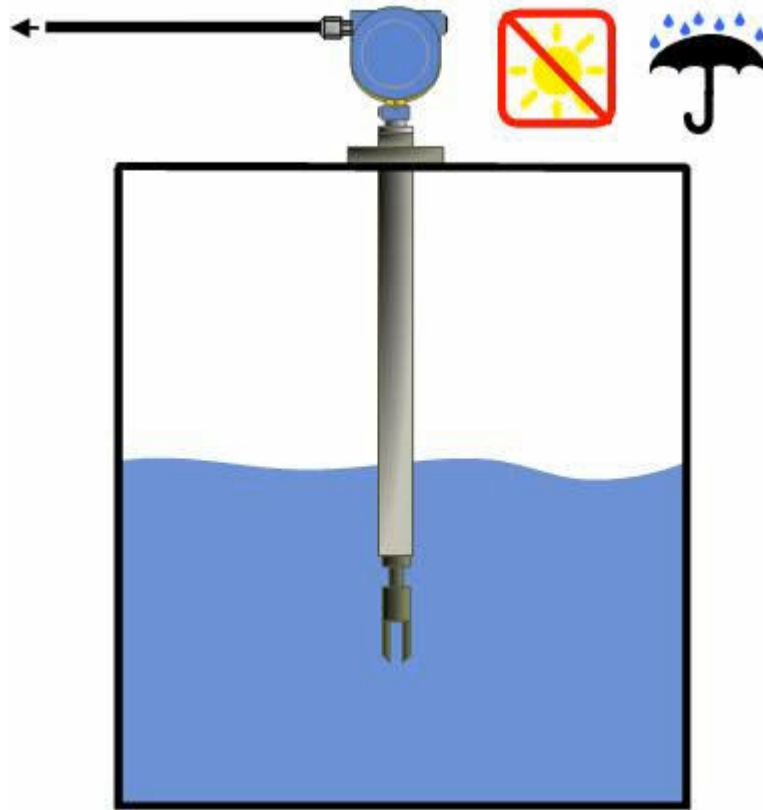

2. To vary the insertion depth of the meter, mount the meter on a standoff section that attaches to the flange (not provided).

Figure 3-19: Closed-tank installation (with standoff)

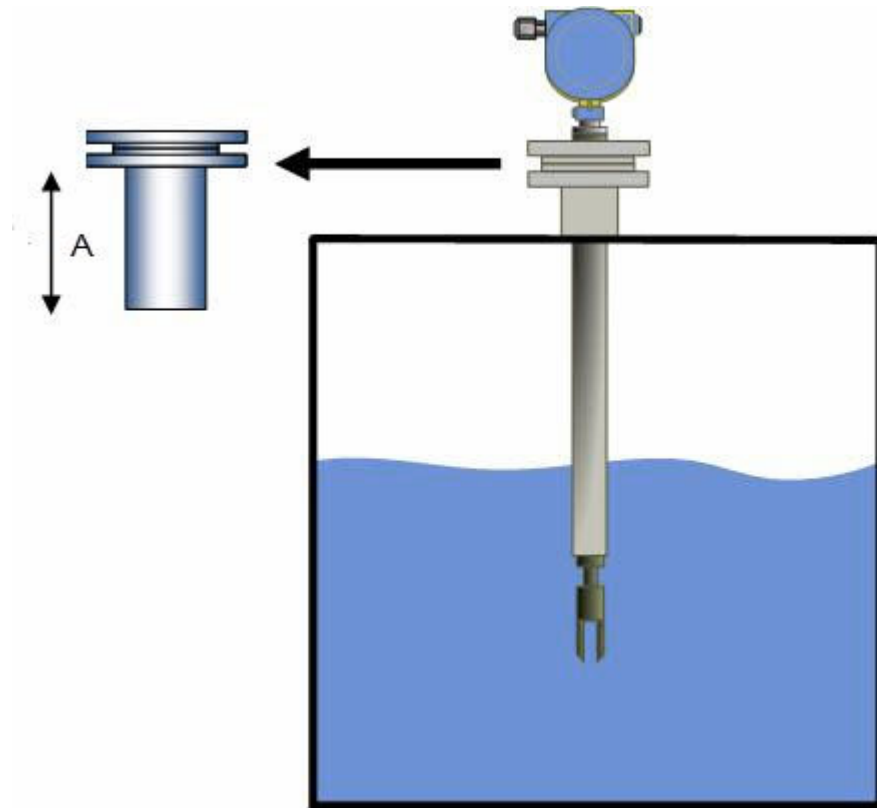

A. Standoff height can vary (provided by customer)

3. Confirm the meter tines are away from the tank wall.

Figure 3-20: Meter placement (away from tank wall)

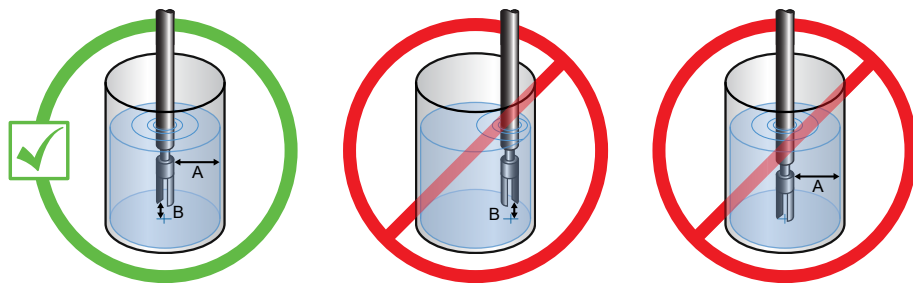

A. 7.87 in (200 mm)
B. 2 in (51 mm)

4. Confirm the meter tines are immersed in fluid.

Figure 3-21: Meter placement (immersed in fluid)

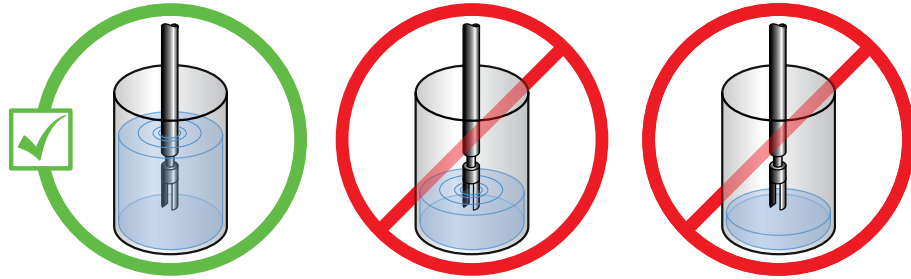

5. Confirm the meter placement has allowed for the flexing of the tank lid to prevent the meter from being pushed towards a tank wall or into the path of disturbed flow.

Figure 3-22: Meter placement (allowance for tank lid flexing)



A. 7.87 in (200 mm)

6. Confirm the meter tines are placed away from objects and disturbed flow.

Figure 3-23: Meter placement (distance from objects and disturbed flow)

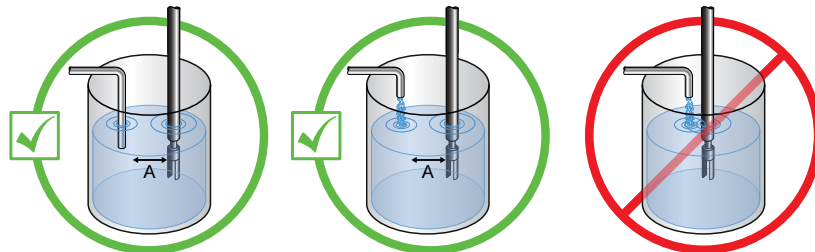

A. 7.87 in (200 mm)

7. If flow exists, confirm the meter tines are aligned so that the flow is directed towards or through the gap between the tines.

Figure 3-24: Meter placement (flow direction through tine gap)

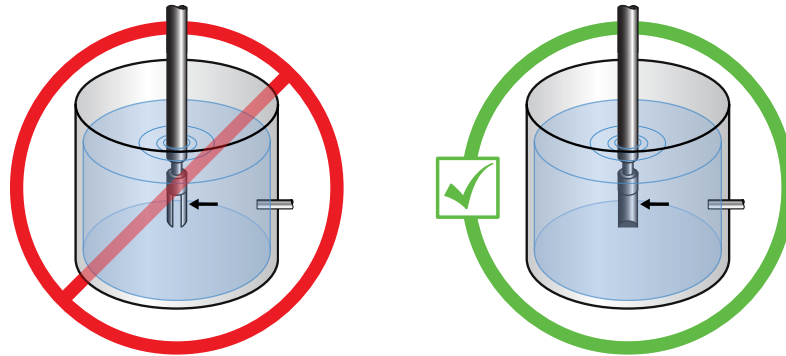

8. Confirm the meter tines are kept away from deposit buildup.

Figure 3-25: Meter placement (away from deposit buildup)

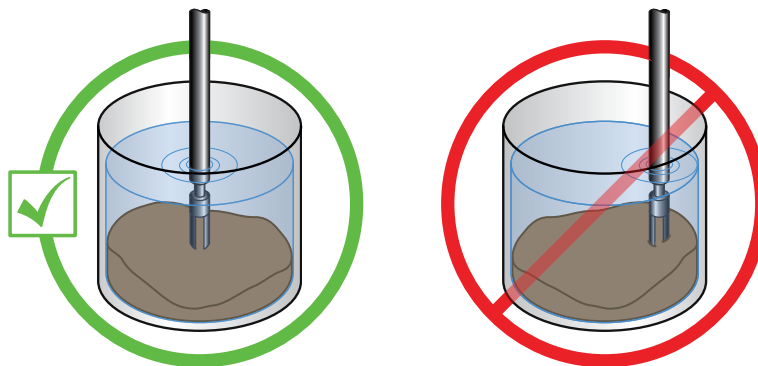

3.6 Attach the PFA ring and circlip

You attach the PFA ring (and circlip) around the boss on the underside of the meter flange to center the meter tines within a 2 in (51 mm) Schedule 40 or 80 pipe. The circlip holds the ring in place.

Procedure

See the figure below for information on attaching the PFA ring and circlip to the meter.

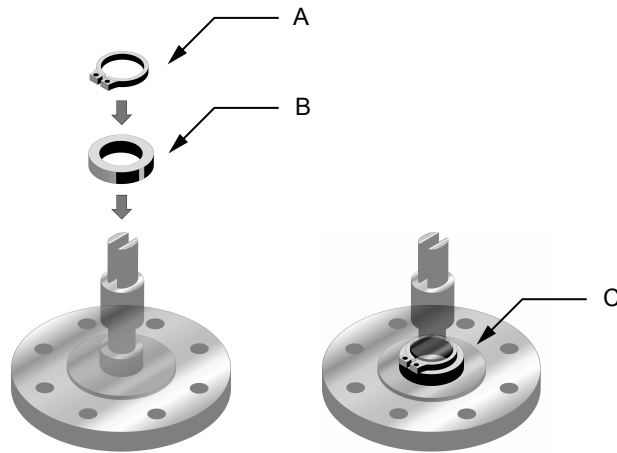

- A. Circlip
- B. PFA ring
- C. PFA ring and circlip attached

3.7 Rotate the electronics on the meter (optional)

You can rotate the transmitter on the meter up to 90°.

Procedure

1. Using a 4 mm hex key, loosen the cap screw that holds the transmitter in place.

Figure 3-26: Component to secure transmitter in place

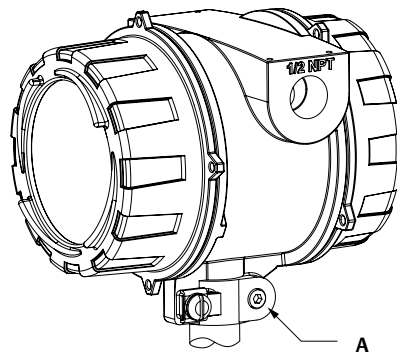

- A. M5 socket-head cap screw

2. Rotate the transmitter clockwise to the desired orientation up to 90°.
3. Secure the cap screw in place and tighten to 60 in lbf (7 N m).

3.8 Rotate the display on the transmitter (optional)

The display on the transmitter electronics module can be rotated 90° or 180° from the original position.

Figure 3-27: Display components

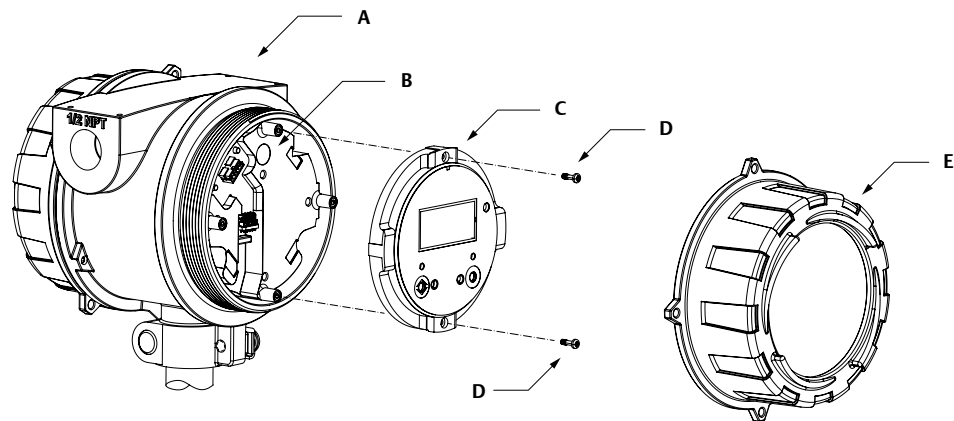

- A. Transmitter housing
- B. Sub-bezel
- C. Display module
- D. Display screws
- E. Display cover

Procedure

1. If the meter is powered up, power it down.
2. Turn the display cover counterclockwise to remove it from the main enclosure.
3. Carefully loosen (and remove if necessary) the semi-captive display screws while holding the display module in place.
4. Carefully pull the display module out of the main enclosure until the sub-bezel pin terminals are disengaged from the display module.

Note

If the display pins come out of the board stack with the display module, remove the pins and reinstall them.

5. Rotate the display module to the desired position.
6. Insert the sub-bezel pin terminals into the display module pin holes to secure the display in its new position.
7. If you have removed the display screws, line them up with the matching holes on the sub-bezel, then reinsert and tighten them.

8. Place the display cover onto the main enclosure.
9. Turn the display cover clockwise until it is snug.
10. If appropriate, power up the meter.

4 Wiring

4.1 Terminals and wiring requirements

Three pairs of wiring terminals are available for transmitter outputs. These outputs vary depending on your transmitter output option ordered. The Analog (mA), Time Period Signal (TPS), and Discrete Output (DO) require external power, and must be connected to an independent 24 VDC power supply.

The screw connectors for each output terminal accept a maximum wire size of 14 AWG (2.08 mm²).

Important

- Output wiring requirements depend on whether the meter will be installed in a safe area or a hazardous area. It is your responsibility to verify that this installation meets all corporate, local, and national safety requirements and electrical codes.
- If you will configure the meter to poll an external temperature or pressure device, you must wire the mA output to support HART communications. You may use either HART/mA single-loop wiring or HART multi-drop wiring.

Table 4-1: Transmitter outputs

Transmitter version	Output channels		
	A	B	C
Analog	4–20 mA + HART	4–20 mA	Modbus/RS-485
Processor for remote-mount 2700 fieldbus transmitter	Disabled	Disabled	Modbus/RS-485
Time period signal (TPS)	4–20 mA + HART (passive)	Time Period Signal (TPS)	Modbus/RS-485
Discrete	4–20 mA + HART (passive)	Discrete output	Modbus/RS-485

4.2 Explosion-proof/flameproof or non-hazardous output wiring

4.2.1 Wire Analog outputs in explosion-proof/flameproof or non-hazardous area

CAUTION

Meter installation and wiring should be performed by suitably trained personnel only in accordance with the applicable code of practice.

Procedure

Wire to the appropriate output terminal and pins (see the following figure).

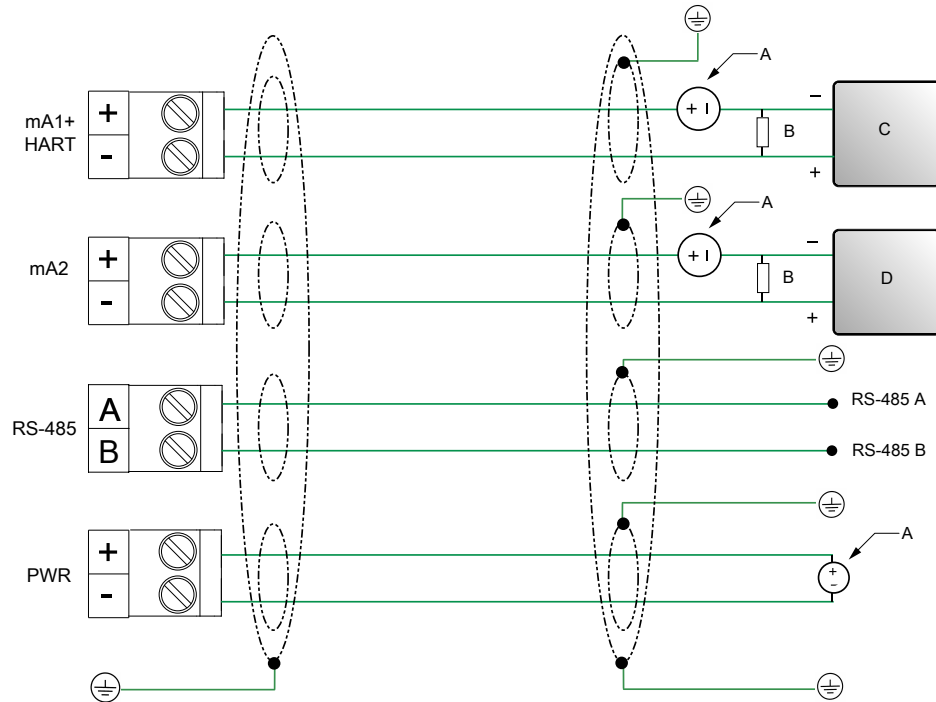

- A. 24 VDC
- B. R_{load} (250 Ω resistance)
- C. HART-compatible host or controller; and/or signal device
- D. Signal device

Note

For operating the milliamp outputs with a 24V supply, a maximum total loop resistance of 657 Ω is allowed.

⚠ CAUTION

- To meet the EC Directive for Electromagnetic Compatibility (EMC), use a suitable instrumentation cable to connect the meter. The instrumentation cable should have individual screens, foil or braid over each twisted pair, and an overall screen to cover all cores. Where permissible, connect the overall screen to earth at both ends (360° bonded at both ends). Connect the inner individual screens at only the controller end.
- Use metal cable glands where the cables enter the meter amplifier box. Fit unused cable ports with metal blanking plugs.

4.2.2 Wire Time Period Signal (TPS) or Discrete Output in explosion-proof/flameproof or non-hazardous area



CAUTION

Meter installation and wiring should be performed by suitably trained personnel only in accordance with the applicable code of practice.

Procedure

Wire to the appropriate output terminal and pins (see [Figure 4-1](#)).

Figure 4-1: Wiring the TPS or Discrete Output version

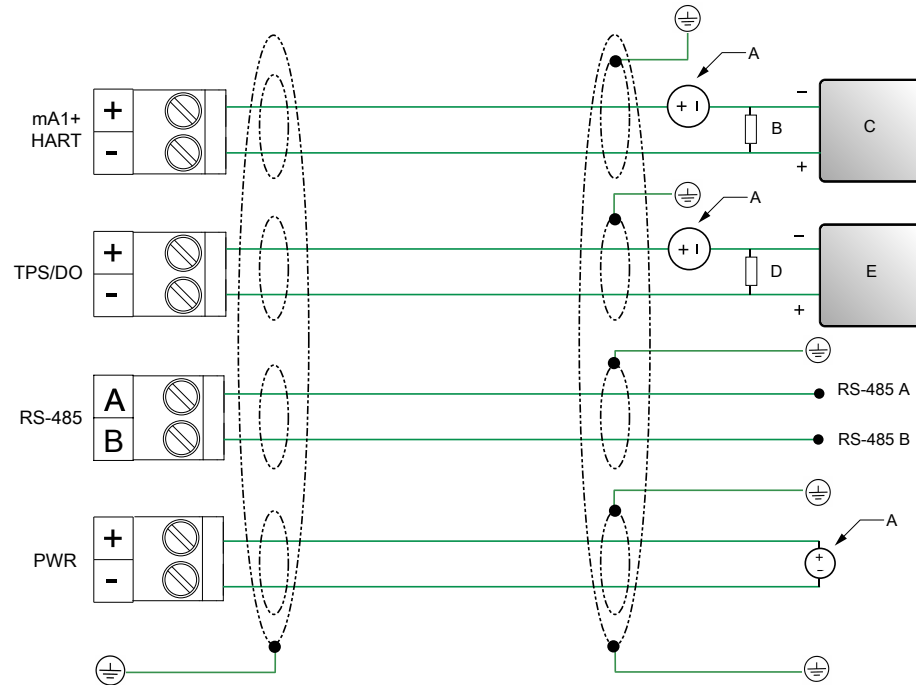

- A. 24 VDC
- B. R_{load} (250 Ω resistance)
- C. HART-compatible host or controller; and/or signal device
- D. R_{load} (500 Ω resistance recommended)
- E. Signal converter/flow computer or Discrete Input device

Note

- For operating the milliamp output with a 24V supply, a maximum total loop resistance of 657 Ω is allowed.
- When operating the TPS or Discrete Output with a 24 VDC power supply, a maximum total loop resistance of 1300 Ω is allowed.

CAUTION

- To meet the EC Directive for Electromagnetic Compatibility (EMC), use a suitable instrumentation cable to connect the meter. The instrumentation cable should have individual screens, foil or braid over each twisted pair, and an overall screen to cover all cores. Where permissible, connect the overall screen to earth at both ends (360° bonded at both ends). Connect the inner individual screens at only the controller end.
- Use metal cable glands where the cables enter the meter amplifier box. Fit unused cable ports with metal blanking plugs.

4.3 Processor wiring for remote-mount 2700 fieldbus

4.3.1 RS-485 entity parameters for remote-mount 2700 fieldbus

⚠ DANGER

- Hazardous voltage can cause severe injury or death. To reduce the risk of hazardous voltage, shut off power before wiring the meter.
- Improper wiring in a hazardous environment can cause an explosion. Install the meter only in an area that complies with the hazardous classification tag on the meter.

Table 4-2: RS-485 output and cable entity parameters

Cable parameters for intrinsically safe circuit (linear)	
Voltage (U_i)	17.22 VDC
Current (I_i)	484 mA
Maximum capacitance (C_i)	1 nF
Maximum inductance (L_i)	Negligible
Cable parameters for Ex ib IIB, Ex ib IIC	
Voltage (U_o)	9.51 VDC
Current (instantaneous) (I_o)	480 mA
Current (steady state) (I)	106 mA
Power (P_o)	786 mW
Internal resistance (R_i)	19.8 Ω
Cable parameters for Group IIC	
Maximum external capacitance (C_o)	85 nF
Maximum external inductance (L_o)	25 μ H
Maximum external inductance/resistance ratio (L_o/R_o)	31.1 μ H/ Ω
Cable parameters for Group IIB	
Maximum external capacitance (C_o)	660 nF
Maximum external inductance (L_o)	260 μ H
Maximum external inductance/resistance ratio (L_o/R_o)	124.4 μ H/ Ω

4.3.2 Connect 4-wire cable

4-wire cable types and usage

Micro Motion offers two types of 4-wire cable: shielded and armored. Both types contain shield drain wires.

The cable supplied by Micro Motion consists of one pair of red and black 18 AWG (0.823 mm²) wires for the VDC connection, and one pair of white and green 22 AWG (0.326 mm²) wires for the RS-485 connection.

User-supplied cable must meet the following requirements:

- Twisted pair construction.
- Applicable hazardous area requirements, if the core processor is installed in a hazardous area.
- Wire gauge appropriate for the cable length between the core processor and the transmitter.
- Wire gauge of 22 AWG (0.326 mm²) or larger, with a maximum cable length of 1,000 ft (305 m).

Prepare a cable with a metal conduit

Prerequisites

Note

If you are installing unshielded cable in continuous metallic conduit with 360° termination shielding, you only need to prepare the cable – you do not need to perform the shielding procedure.

Procedure

1. Remove the integral processor cover using a flat-blade screw driver.
2. Run the conduit to the sensor.
3. Pull the cable through the conduit.
4. Cut the drain wires and let them float at both ends of the conduit.

Prepare a cable with user-supplied cable glands

Prerequisites

Important

For user-supplied cable glands, the gland must be capable of terminating the drain wires.

Procedure

1. Remove the core processor cover using a flat-blade screw driver.
2. Pass the wires through the gland.
3. Terminate the shield and drain wires inside the gland.
4. Assemble the gland according to vendor instructions.

Prepare a cable with Micro Motion-supplied cable glands

Procedure

1. Remove the core processor cover using a flat-blade screw driver.
2. Pass the wires through the gland nut and clamping insert.

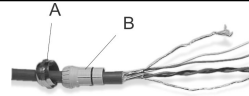

- A. Gland nut
B. Clamping insert

3. Strip the cable jacket.

Option	Description
NPT gland type	Strip 4.5 in (114 mm)
M20 gland type	Strip 4.25 in (108 mm)

4. Remove the clear wrap and filler material.
5. Strip most of the shielding.

Option	Description
NPT gland type	Strip all but 0.75 in (19 mm)
M20 gland type	Strip all but 0.5 in (13 mm)

6. Wrap the drain wires twice around the shield and cut off the excess drain wires.



- A. Drain wires wrapped around shield

7. For foil (shielded cable) only:

Note

For braided (armored cable) skip this step and continue to the next step.

Option	Description
NPT gland type	<ol style="list-style-type: none"> a. Slide the shielded heat shrink over the drain wires. Ensure that the wires are completely covered. b. Apply heat 250 °F (121.1 °C) to shrink the tubing. Do not burn the cable. c. Position the clamping insert so the interior end is flush with the braid of the heat shrink.

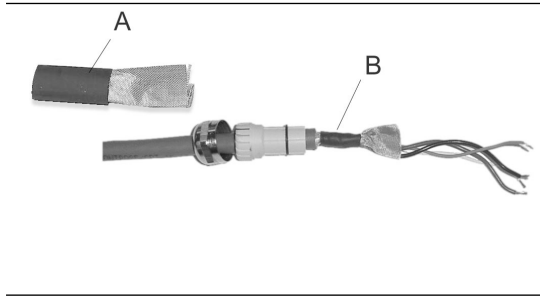
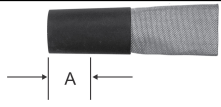
Option	Description
	<div style="text-align: center;">  <p>A. Shielded heat shrink B. After heat is applied</p> </div>
M20 gland type	<p>Trim 0.3 in (8 mm).</p> <div style="text-align: center;">  <p>A. Trim</p> </div>

- Assemble the gland by folding the shield or braid back over the clamping insert and 0.125 in (3 mm) past the O-ring.

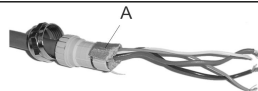

A. Shield folded back

- Install the gland body into the conduit opening on the core processor housing.
- Insert the wires through the gland body and tighten the gland nut onto the gland body.

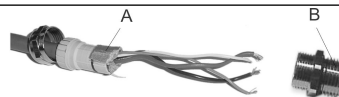

A. Shield folded back
B. Gland body

4.3.3 Processor wiring for the remote-mount 2700 fieldbus option

The following figure illustrates how to connect the individual wires of a 4-wire cable to the processor terminals. For detailed information on mounting and wiring to the remote-mount 2700 fieldbus transmitter, see the transmitter installation manual.

Figure 4-2: Processor (Modbus/RS-485) connections to the remote-mount 2700 fieldbus transmitter

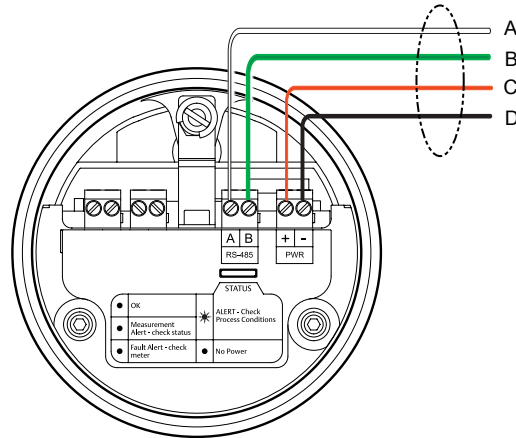

- A. White wire to RS-485/A terminal
- B. Green wire to RS-485/B terminal
- C. Red wire to Power supply (+) terminal
- D. Black wire to Power supply (-) terminal

Important

- To meet the EC Directive for EMC (Electromagnetic Compatibility), it is recommended that the meter be connected using a suitable instrumentation cable. The instrumentation cable should have individual screens, foil or braid over each twisted pair and an overall screen to cover all cores. Where permissible, the overall screen should be connected to earth at both ends (360° bonded at both ends). The inner individual screens should be connected at only one end, the controller end.
- Metal cable glands should be used where the cables enter the meter amplifier box. Unused cable ports should be fitted with metal blanking plugs.

 **CAUTION**

- To meet the EC Directive for Electromagnetic Compatibility (EMC), use a suitable instrumentation cable to connect the meter. The instrumentation cable should have individual screens, foil or braid over each twisted pair, and an overall screen to cover all cores. Where permissible, connect the overall screen to earth at both ends (360° bonded at both ends). Connect the inner individual screens at only the controller end.
- Use metal cable glands where the cables enter the meter amplifier box. Fit unused cable ports with metal blanking plugs.

4.5 Wiring to signal converters and/or flow computers

For meters with a Time Period Signal (TPS) output, you can wire the meter to an signal converter or flow computer directly. The following information provides wiring diagrams for making those connections in safe and hazardous environments.

When wiring the meter to an active HART host or signal converter/flow computer, you are not required to provide external power to the output connections. These active devices provide the 24 VDC necessary for these connections.

4.5.1 Wire to a signal converter in an explosion-proof or non-hazardous area

Use this procedure to wire to a signal converter/flow computer in an explosion-proof/flameproof or non-hazardous area.

Figure 4-4: Wiring to a signal converter/flow computer in an explosion-proof/flameproof or non-hazardous area

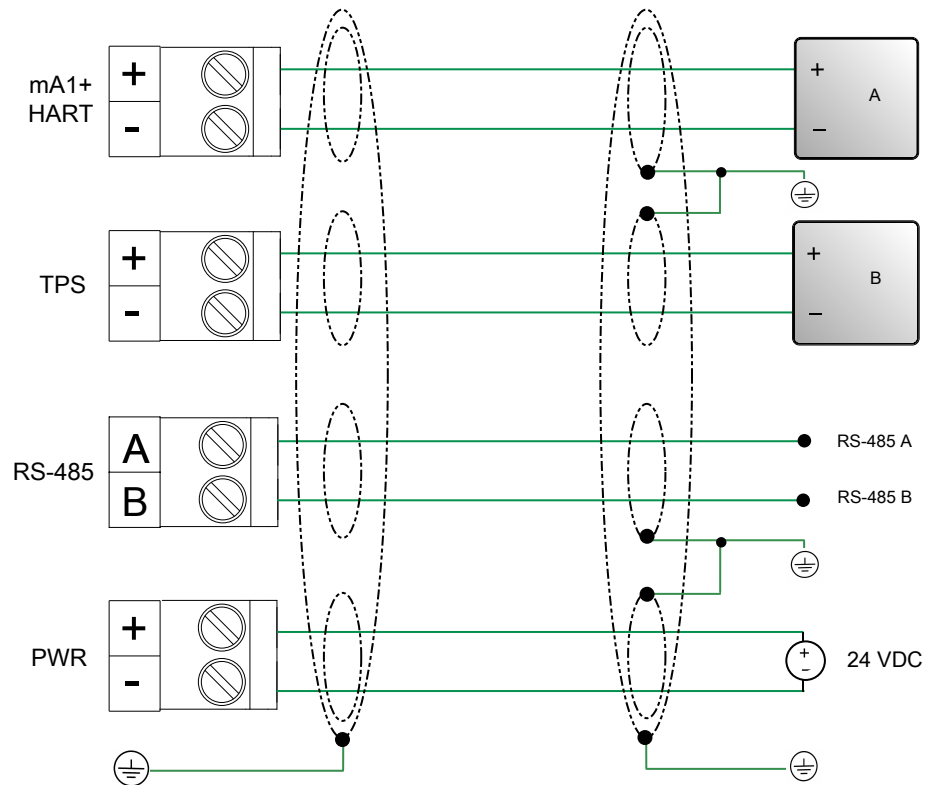

- A. Active HART host
- B. Active signal converter/flow computer

CAUTION

- To meet the EC Directive for Electromagnetic Compatibility (EMC), use a suitable instrumentation cable to connect the meter. The instrumentation cable should have individual screens, foil or braid over each twisted pair, and an overall screen to cover all cores. Where permissible, connect the overall screen to earth at both ends (360° bonded at both ends). Connect the inner individual screens at only the controller end.
- Use metal cable glands where the cables enter the meter amplifier box. Fit unused cable ports with metal blanking plugs.

5 Grounding

The meter must be grounded according to the standards that are applicable at the site. The customer is responsible for knowing and complying with all applicable standards.

Prerequisites

Use the following guides for grounding practices:

- In Europe, IEC 60079-14 is applicable to most installations, in particular Sections 16.2.2.3 and 16.2.2.4.
- In the U.S.A. and Canada, ISA 12.06.01 Part 1 provides examples with associated applications and requirements.

If no external standards are applicable, follow these guidelines to ground the sensor:

- Use copper wire, 14 AWG (2.08 mm²) or larger wire size.
- Keep all ground leads as short as possible, less than 1 Ω impedance.
- Connect ground leads directly to earth, or follow plant standards.



CAUTION

Ground the flowmeter to earth, or follow ground network requirements for the facility. Improper grounding can cause measurement error.

Procedure

- Check the joints in the pipeline.
 - If the joints in the pipeline are ground-bonded, the sensor is automatically grounded and no further action is necessary (unless required by local code).
 - If the joints in the pipeline are not grounded, connect a ground wire to the grounding screw located on the sensor electronics.

Tip

The sensor electronics may be a transmitter, core processor, or junction box. The grounding screw may be internal or external.



MMI-20020989
Rev. AE
2019

Micro Motion Inc. USA

Worldwide Headquarters
7070 Winchester Circle
Boulder, Colorado USA 80301
T +1 303-527-5200
T +1 800-522-6277
F +1 303-530-8459
www.emerson.com

Micro Motion Europe

Emerson Automation Solutions
Neonstraat 1
6718 WX Ede
The Netherlands
T +31 (0) 70 413 6666
F +31 (0) 318 495 556
www.micromotion.nl

Micro Motion Asia

Emerson Automation Solutions
1 Pandan Crescent
Singapore 128461
Republic of Singapore
T +65 6363-7766
F +65 6770-8003

Micro Motion United Kingdom

Emerson Automation Solutions
Emerson Process Management Limited
Horsfield Way
Bredbury Industrial Estate
Stockport SK6 2SU U.K.
T +44 0870 240 1978
F +44 0800 966 181

©2019 Micro Motion, Inc. All rights reserved.

The Emerson logo is a trademark and service mark of Emerson Electric Co. Micro Motion, ELITE, ProLink, MVD and MVD Direct Connect marks are marks of one of the Emerson Automation Solutions family of companies. All other marks are property of their respective owners.

MICRO MOTION™

