

Micro Motion® Fork Density Meters (FDM)

Configuration and Use Manual

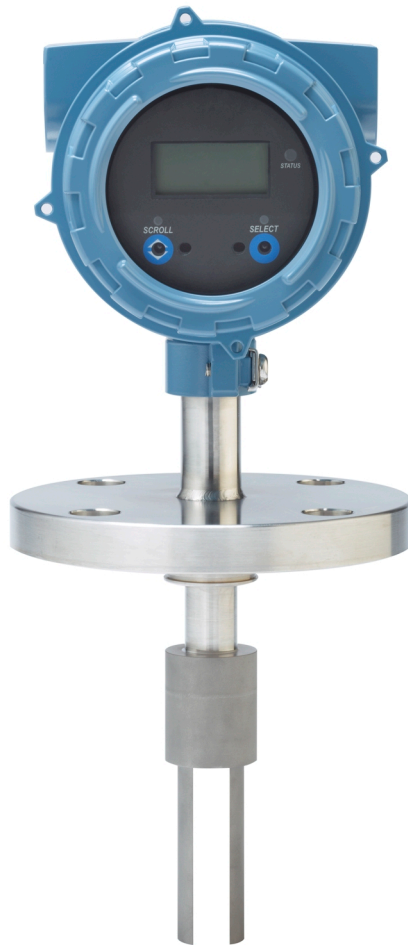

Safety messages

Safety messages are provided throughout this manual to protect personnel and equipment. Read each safety message carefully before proceeding to the next step.

Emerson Flow customer service

Email:

- Worldwide: flow.support@emerson.com
- Asia-Pacific: APflow.support@emerson.com

Telephone:

North and South America		Europe and Middle East		Asia Pacific	
United States	800-522-6277	U.K.	0870 240 1978	Australia	800 158 727
Canada	+1 303-527-5200	The Netherlands	+31 (0) 704 136 666	New Zealand	099 128 804
Mexico	+41 (0) 41 7686 111	France	0800 917 901	India	800 440 1468
Argentina	+54 11 4837 7000	Germany	0800 182 5347	Pakistan	888 550 2682
Brazil	+55 15 3413 8000	Italy	8008 77334	China	+86 21 2892 9000
Venezuela	+58 26 1731 3446	Central & Eastern	+41 (0) 41 7686 111	Japan	+81 3 5769 6803
		Russia/CIS	+7 495 981 9811	South Korea	+82 2 3438 4600
		Egypt	0800 000 0015	Singapore	+65 6 777 8211
		Oman	800 70101	Thailand	001 800 441 6426
		Qatar	431 0044	Malaysia	800 814 008
		Kuwait	663 299 01		
		South Africa	800 991 390		
		Saudi Arabia	800 844 9564		
		UAE	800 0444 0684		

Contents

Part I Getting Started

Chapter 1	Before you begin	3
1.1	About this manual	3
1.2	Model codes and device types	3
1.3	Communications tools and protocols	4
1.4	Additional documentation and resources	5
Chapter 2	Quick start	7
2.1	Power up the transmitter	7
2.2	Check meter status	7
2.3	Make a startup connection to the transmitter	8

Part II Configuration and commissioning

Chapter 3	Introduction to configuration and commissioning	13
3.1	Default values	13
3.1.1	FDM default values	13
3.2	Enable access to the off-line menu of the display	14
3.3	Disable HART security	15
3.4	Set the HART lock	17
3.5	Restore the factory configuration	17
Chapter 4	Configure process measurement	19
4.1	Verify the calibration factors	19
4.1.1	Calibration factors	20
4.2	Configure line density measurement	20
4.2.1	Configure Density Measurement Unit	20
4.2.2	Configure Density Damping	22
4.2.3	Configure Density Cutoff	23
4.2.4	Configure two-phase flow parameters	24
4.3	Configure temperature measurement	25
4.3.1	Configure Temperature Measurement Unit	25
4.3.2	Configure Temperature Damping	26
4.3.3	Configure Temperature Input	27
4.4	Configure the pressure input	30
4.4.1	Configure the pressure input using ProLink III	30
4.4.2	Configure the pressure input using the Field Communicator	32
4.4.3	Options for Pressure Measurement Unit	33
4.5	Set up the API referral application	34
4.5.1	Set up the API referral application using ProLink III	34
4.5.2	Set up the API referral application using the Field Communicator	40
4.6	Set up concentration measurement	47
4.6.1	Preparing to set up concentration measurement	47
4.6.2	Set up concentration measurement using ProLink III	48

4.6.3	Set up concentration measurement using the Field Communicator	55
4.6.4	Using equations to calculate specific gravity, °Baumé, °Brix, °Plato, and °Twaddell	60
4.6.5	Matrix switching	61
4.6.6	Measuring Net Mass Flow Rate and Net Volume Flow Rate	63
4.7	Set up flow rate measurement	63
4.7.1	Set up flow rate measurement using ProLink III	63
4.7.2	Set up flow rate measurement using the Field Communicator	65
Chapter 5	Configure device options and preferences	67
5.1	Configure the transmitter display	67
5.1.1	Configure the language used for the display	67
5.1.2	Configure the process variables and diagnostic variables shown on the display	68
5.1.3	Configure the number of decimal places (precision) shown on the display	68
5.1.4	Configure the refresh rate of data shown on the display	69
5.1.5	Enable or disable automatic scrolling through the display variables	69
5.2	Enable or disable the Acknowledge All Alerts display command	70
5.3	Configure security for the display menus	71
5.4	Configure alert handling	72
5.4.1	Configure Fault Timeout	72
5.4.2	Configure Alert Severity	73
5.5	Configure informational parameters	75
Chapter 6	Integrate the meter with the control system	77
6.1	Configure Channel B	77
6.2	Configure the mA output	78
6.2.1	Configure mA Output Process Variable	78
6.2.2	Configure Lower Range Value (LRV) and Upper Range Value (URV)	80
6.2.3	Configure Added Damping	81
6.2.4	Configure mA Output Fault Action and mA Output Fault Level	82
6.3	Configure the discrete output	84
6.3.1	Configure Discrete Output Source	84
6.3.2	Configure Discrete Output Polarity	85
6.3.3	Configure Discrete Output Fault Action	86
6.4	Configure an enhanced event	87
6.5	Configure HART/Bell 202 communications	88
6.5.1	Configure basic HART parameters	88
6.5.2	Configure HART variables (PV, SV, TV, QV)	89
6.5.3	Configure burst communications	91
6.6	Configure Modbus communications	95
6.7	Configure Digital Communications Fault Action	97
6.7.1	Options for Digital Communications Fault Action	97
Chapter 7	Complete the configuration	99
7.1	Test or tune the system using sensor simulation	99
7.2	Back up transmitter configuration	99
7.3	Enable HART security	100
Part III	Operations, maintenance, and troubleshooting	
Chapter 8	Transmitter operation	105
8.1	Record the process variables	105
8.2	View process variables and diagnostic variables	105

8.2.1	View process variables using the display	105
8.2.2	View process variables and other data using ProLink III	106
8.2.3	View process variables using the Field Communicator	106
8.3	View and acknowledge status alerts	107
8.3.1	View and acknowledge alerts using the display	107
8.3.2	View and acknowledge alerts using ProLink III	109
8.3.3	View alerts using the Field Communicator	110
8.3.4	Alert data in transmitter memory	110
Chapter 9	Measurement support	113
9.1	Perform the inline calibration check procedure	113
9.1.1	Perform the inline calibration check using ProLink III	114
9.1.2	Perform the inline calibration check using the Field Communicator	115
9.2	Perform the Known Density Verification procedure	115
9.2.1	Perform the Known Density Verification procedure using the display	116
9.2.2	Perform the Known Density Verification procedure using ProLink III	117
9.2.3	Perform the Known Density Verification procedure using the Field Communicator	117
9.3	Adjust density measurement with Density Offset or Density Meter Factor	118
9.4	Perform density offset calibration	119
9.4.1	Perform density offset calibration using the display	120
9.4.2	Perform density offset calibration using ProLink III	121
9.4.3	Perform density offset calibration using the Field Communicator	121
9.5	Perform temperature calibration	122
9.5.1	Perform temperature calibration using the display	122
9.5.2	Perform temperature calibration using ProLink III	123
9.5.3	Perform temperature calibration using the Field Communicator	123
9.6	Adjust concentration measurement with Trim Offset	124
9.7	Adjust concentration measurement with Trim Slope and Trim Offset	125
9.8	Set up user-defined calculations	127
9.8.1	Equations used in user-defined calculations	129
9.8.2	Measurement units used in user-defined calculations	129
Chapter 10	Troubleshooting	131
10.1	Quick guide to troubleshooting	131
10.2	Check power supply wiring	132
10.3	Check grounding	133
10.4	Perform loop tests	133
10.4.1	Perform loop tests using the display	134
10.4.2	Perform loop tests using ProLink III	135
10.4.3	Perform loop tests using the Field Communicator	136
10.5	Status LED states	137
10.6	Status alerts, causes, and recommendations	138
10.7	Density measurement problems	143
10.8	Temperature measurement problems	144
10.9	API referral problems	145
10.10	Concentration measurement problems	145
10.11	Milliamp output problems	146
10.12	Discrete output problems	148
10.13	Time Period Signal (TPS) output problems	148
10.14	Using sensor simulation for troubleshooting	149
10.15	Trim mA outputs	149

10.15.1	Trim mA outputs using ProLink III	149
10.15.2	Trim mA outputs using the Field Communicator	150
10.16	Check HART communications	151
10.17	Check Lower Range Value and Upper Range Value	152
10.18	Check mA Output Fault Action	153
10.19	Check for radio frequency interference (RFI)	153
10.20	Check the cutoffs	153
10.21	Check for two-phase flow (slug flow)	154
10.22	Check the drive gain	154
10.22.1	Collect drive gain data	155
10.23	Check for internal electrical problems	155
10.24	Locate a device using the HART 7 Squawk feature	156

Appendices and reference

Appendix A	Calibration certificate	157
A.1	Sample calibration certificate	157
Appendix B	Using the transmitter display	159
B.1	Components of the transmitter interface	159
B.2	Use the optical switches	159
B.3	Access and use the display menu system	160
B.3.1	Enter a floating-point value using the display	161
B.4	Display codes for process variables	164
B.5	Codes and abbreviations used in display menus	164
Appendix C	Using ProLink III with the transmitter	177
C.1	Basic information about ProLink III	177
C.2	Connect with ProLink III	178
C.2.1	Connection types supported by ProLink III	178
C.2.2	Connect with ProLink III over Modbus/RS-485	179
C.2.3	Connect with ProLink III over HART/Bell 202	182
Appendix D	Using the Field Communicator with the transmitter	191
D.1	Basic information about the Field Communicator	191
D.2	Connect with the Field Communicator	192
Appendix E	Concentration measurement matrices, derived variables, and process variables	195
E.1	Standard matrices for the concentration measurement application	195
E.2	Concentration measurement matrices available by order	196
E.3	Derived variables and calculated process variables	198

Part I

Getting Started

Chapters covered in this part:

- *Before you begin*
- *Quick start*

1 Before you begin

Topics covered in this chapter:

- [About this manual](#)
- [Model codes and device types](#)
- [Communications tools and protocols](#)
- [Additional documentation and resources](#)

1.1 About this manual

This manual provides information to help you configure, commission, use, maintain, and troubleshoot the Micro Motion Fork Density Meter (FDM).

The following versions of the FDM are documented in this manual:

- Fork Density Meter with Analog Outputs
- Fork Density Meter with Analog Output and Discrete Output
- Fork Density Meter with Time Period Signal Output

For the Fork Density Meter with FOUNDATION™ Fieldbus, see *Micro Motion® Fork Density Meters with FOUNDATION™ Fieldbus: Configuration and Use Manual*.

Important

This manual assumes that the following conditions apply:

- The meter has been installed correctly and completely, according to the instructions in the installation manual.
 - The installation complies with all applicable safety requirements.
 - The user is trained in all government and corporate safety standards.
-

1.2 Model codes and device types

Your device can be identified by the model code on the device tag.

Table 1-1: Model codes and device types

Model code	Device nickname	I/O	Electronics mounting
FDM****C	FDM mA	<ul style="list-style-type: none"> • Two mA outputs • RS-485 terminals 	Integral
FDM****D	FDM DO	<ul style="list-style-type: none"> • One mA output • One discrete output • RS-485 terminals 	Integral

Table 1-1: Model codes and device types (continued)

Model code	Device nickname	I/O	Electronics mounting
FDM****B	FDM TPS	<ul style="list-style-type: none"> One mA output One Time Period Signal output 	Integral
FDM****A	FDM FF	<ul style="list-style-type: none"> FOUNDATION™ field-bus 	4-wire remote transmitter

Restriction

The FDM and FDM FF support a complete set of application and configuration options. The FDM DO and FDM TPS support a subset of configuration options. Refer to the product data sheet for details.

1.3 Communications tools and protocols

You can use several different communications tools and protocols to interface with the device. You may use different tools in different locations or for different tasks.

Table 1-2: Communications tools, protocols, and related information

Communications tool	Supported protocols	Scope	In this manual	For more information
Display	Not applicable	Basic configuration and commissioning	Complete user information. See Appendix B .	Not applicable
ProLink III	<ul style="list-style-type: none"> Modbus/RS-485 HART/Bell 202 Service port 	Complete configuration and commissioning	Basic user information. See Appendix C .	User manual <ul style="list-style-type: none"> Installed with software On Micro Motion user documentation CD On Micro Motion web site (www.micromotion.com)
Field Communicator	<ul style="list-style-type: none"> HART/Bell 202 	Complete configuration and commissioning	Basic user information. See Appendix D .	User manual on Micro Motion web site (www.micromotion.com)

Tip

You may be able to use other communications tools from Emerson Process Management, such as AMS Suite: Intelligent Device Manager, or the Smart Wireless THUM™ Adapter. Use of AMS or the Smart Wireless THUM Adapter is not discussed in this manual. For more information on the Smart Wireless THUM Adapter, refer to the documentation available at www.micromotion.com.

1.4 Additional documentation and resources

Micro Motion provides additional documentation to support the installation and operation of the device.

Table 1-3: Additional documentation and resources

Topic	Document
Device installation	<i>Micro Motion Fork Density Meters (FDM): Installation Manual</i>
Product data sheet	<i>Micro Motion Fork Density Meters: Product Data Sheet</i>

All documentation resources are available on the Micro Motion web site at www.micromotion.com or on the Micro Motion user documentation DVD.

2 Quick start

Topics covered in this chapter:

- *Power up the transmitter*
- *Check meter status*
- *Make a startup connection to the transmitter*

2.1 Power up the transmitter

The transmitter must be powered up for all configuration and commissioning tasks, or for process measurement.

1. Ensure that all transmitter and sensor covers and seals are closed.

WARNING!

To prevent ignition of flammable or combustible atmospheres, ensure that all covers and seals are tightly closed. For hazardous area installations, applying power while housing covers are removed or loose can cause an explosion.

2. Turn on the electrical power at the power supply.

The transmitter will automatically perform diagnostic routines. During this period, Alert 009 is active. The diagnostic routines should complete in approximately 30 seconds.

Postrequisites

Although the sensor is ready to receive process fluid shortly after power-up, the electronics can take up to 10 minutes to reach thermal equilibrium. Therefore, if this is the initial startup, or if power has been off long enough to allow components to reach ambient temperature, allow the electronics to warm up for approximately 10 minutes before relying on process measurements. During this warm-up period, you may observe minor measurement instability or inaccuracy.

2.2 Check meter status

Check the meter for any error conditions that require user action or that affect measurement accuracy.

1. Wait approximately 10 seconds for the power-up sequence to complete.

Immediately after power-up, the transmitter runs through diagnostic routines and checks for error conditions. During the power-up sequence, Alert A009 is active. This alert should clear automatically when the power-up sequence is complete.

2. Check the status LED on the transmitter.

Table 2-1: Transmitter status reported by status LED

LED state	Description	Recommendation
Green	No alerts are active.	Continue with configuration or process measurement.
Yellow	One or more low-severity alerts are active.	A low-severity alert condition does not affect measurement accuracy or output behavior. You can continue with configuration or process measurement. If you choose, you can identify and resolve the alert condition.
Flashing yellow	Calibration in progress, or Known Density Verification in progress.	The measurement can fluctuate during the calibration process or change as a result of the calibration process. The alert will clear when the calibration is complete. Check the calibration results before continuing.
Red	One or more high-severity alerts are active.	A high-severity alert condition affects measurement accuracy and output behavior. Resolve the alert condition before continuing.

- [View and acknowledge status alerts](#) (Section 8.3)
- [Status alerts, causes, and recommendations](#) (Section 10.6)

2.3 Make a startup connection to the transmitter

For all configuration tools except the display, you must have an active connection to the transmitter to configure the transmitter.

Identify the connection type to use, and follow the instructions for that connection type in the appropriate appendix. Use the default communications parameters shown in the appendix.

Communications tool	Connection type to use	Instructions
ProLink III	Modbus/RS-485 HART/Bell 202	Appendix C
Field Communicator	HART/Bell 202	Appendix D

Postrequisites

(Optional) Change the communications parameters to site-specific values.

- To change the communications parameters using ProLink III, choose Device Tools > Configuration > Communications.
- To change the communications parameters using the Field Communicator, choose Configure > Manual Setup > HART > Communications.

Important

If you are changing communications parameters for the connection type that you are using, you will lose the connection when you write the parameters to the transmitter. Reconnect using the new parameters.

Part II

Configuration and commissioning

Chapters covered in this part:

- *Introduction to configuration and commissioning*
- *Configure process measurement*
- *Configure device options and preferences*
- *Integrate the meter with the control system*
- *Complete the configuration*

3 Introduction to configuration and commissioning

Topics covered in this chapter:

- *Default values*
- *Enable access to the off-line menu of the display*
- *Disable HART security*
- *Set the HART lock*
- *Restore the factory configuration*

3.1 Default values

Default values for your meter are configured at the factory.

Important

Default values are based on your purchase order options. Therefore, the default values described in the following tables may not be the factory default values configured for your system. For absolute accuracy, refer to the configuration sheet that was shipped with your meter.

3.1.1 FDM default values

Table 3-1: FDM default mA scaling values

Variable	Default 4 mA	Default 20 mA
Density	0.500 g/cc	1.500 g/cc
Temperature	-50.000°C -58.000°F	200.000°C 392.000°F
Drive gain	0.000 %	100.000 %
External temperature	-50.000°C -58.000°F	200.000°C 392.000°F
External pressure	0.000 PSIG	1450.377 PSIG
Sensor time period	400 us	2900 us
Special equation output	0	100
API Referral option enabled		
API density	0.500 g/cc	1.500 g/cc
Concentration Measurement option enabled		
CM density @ ref	0.500 g/cc	1.500 g/cc
CM specific gravity	0.500	1.500

Table 3-1: FDM default mA scaling values (continued)

Variable	Default 4 mA	Default 20 mA
CM concentration	0.000 %	100.000 %
External volume flow rate input enabled		
Mass flow rate (calculated)	-0.2 kg/s	0.2 kg/s
Volume flow rate (external)	-0.2 l/s	0.2 l/s
Net mass flow	-0.2 kg/s	0.2 kg/s
Net volume flow	-0.2 l/s	0.2 l/s
Mass flow (mag input)	-0.2 kg/s	0.2 kg/s

Table 3-2: FDM default variables

Default variable	Output option A	Output options B and C
Primary Variable (PV), mA1	Sample Temperature	Density
Secondary Variable (SV), mA2	Sensor Time Period	Temperature
Tertiary Variable (TV)	Density	Sensor Time Period
Quaternary Variable (QV)	Drive Gain	Drive Gain

3.2 Enable access to the off-line menu of the display

Display	<i>Not available</i>
ProLink III	Device Tools > Configuration > Transmitter Display > Display Security
Field Communicator	Configure > Manual Setup > Display > Display Menus > Offline Menu

Overview

By default, access to the off-line menu of the display is enabled. If it is disabled, you must enable it if you want to use the display to configure the transmitter.

Restriction

You cannot use the display to enable access to the off-line menu. You must make a connection from another tool.

3.3 Disable HART security

If you plan to use HART protocol to configure the device, HART security must be disabled. HART security is disabled by default, so you may not need to do this.

Prerequisites

- Strap wrench
- 3 mm hex key

Procedure

1. Power down the meter.
2. Using the strap wrench, loosen the grub screws and remove the transmitter end-cap.

Figure 3-1: Transmitter with end-cap removed

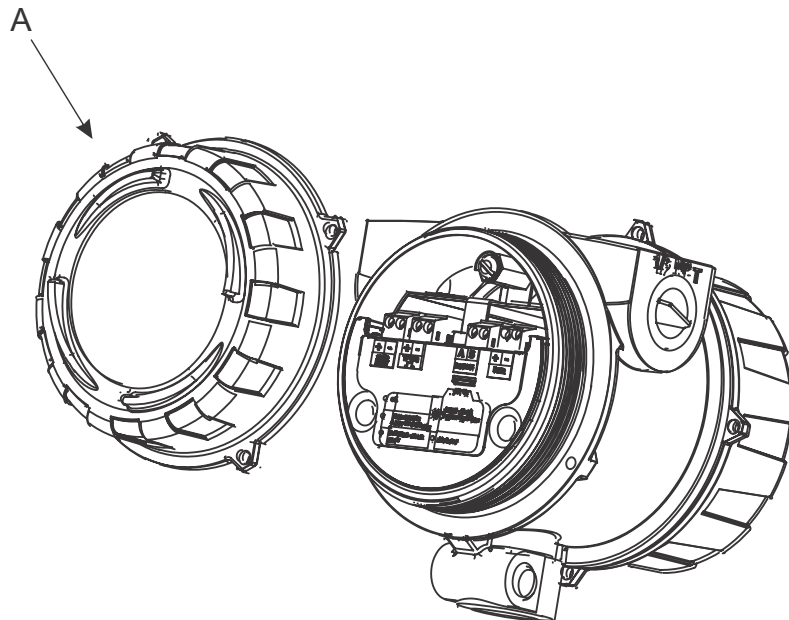

A. Transmitter end-cap

3. Using the hex key, remove the safety spacer.

Figure 3-2: Transmitter with end-cap and safety spacer removed

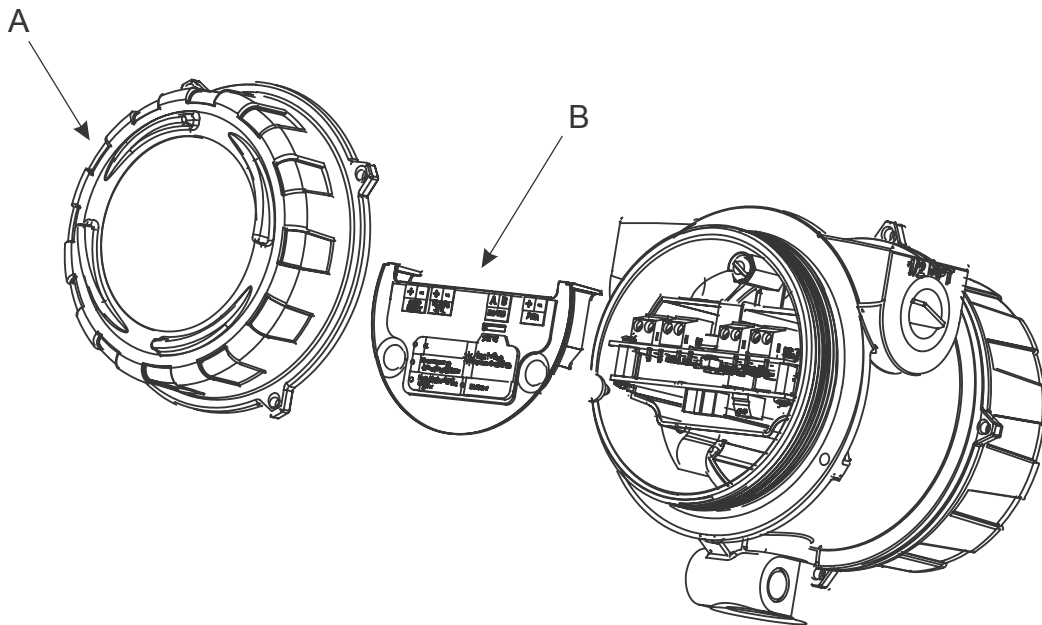

- A. Transmitter end-cap
- B. Safety spacer

4. Move the HART security switch to the OFF position (up).
The HART security switch is the switch on the left.

Figure 3-3: HART security switch

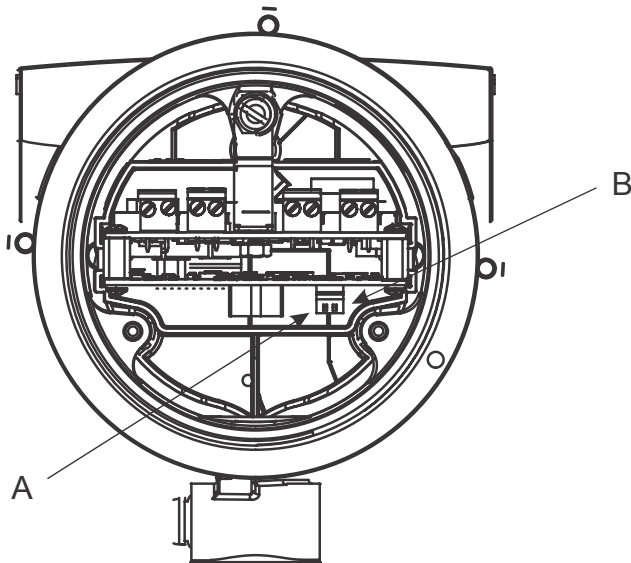

- A. HART security switch
- B. Unused

5. Replace the safety spacer and end-cap.
6. Power up the meter.

3.4 Set the HART lock

If you plan to use a HART connection to configure the device, you can lock out all other HART masters. If you do this, other HART masters will be able to read data from the device but will not be able to write data to the device.

Restrictions

- This feature is available only when you are using the Field Communicator or AMS.
 - This feature is available only with a HART 7 host.
-

Procedure

1. Choose Configure > Manual Setup > Security > Lock/Unlock Device.
2. If you are locking the meter, set Lock Option as desired.

Option	Description
Permanent	Only the current HART master can make changes to the device. The device will remain locked until manually unlocked by a HART master. The HART master can also change Lock Option to Temporary.
Temporary	Only the current HART master can make changes to the device. The device will remain locked until manually unlocked by a HART master, or a power-cycle or device reset is performed. The HART master can also change Lock Option to Permanent.
Lock All	No HART masters are allowed to make changes to the configuration. Before changing Lock Option to Permanent or Temporary, the device must be unlocked. Any HART master can be used to unlock the device.

Postrequisites

To avoid future confusion or difficulties, ensure that the device is unlocked after you have completed your tasks.

3.5 Restore the factory configuration

Display	<i>Not available</i>
ProLink III	Device Tools > Configuration Transfer > Restore Factory Configuration
Field Communicator	Service Tools > Maintenance > Reset/Restore > Restore Factory Configuration

Overview

Restoring the factory configuration returns the transmitter to a known operational configuration. This may be useful if you experience problems during configuration.

Tip

Restoring the factory configuration is not a common action. You may want to contact Micro Motion to see if there is a preferred method to resolve any issues.

4 Configure process measurement

Topics covered in this chapter:

- [Verify the calibration factors](#)
- [Configure line density measurement](#)
- [Configure temperature measurement](#)
- [Configure the pressure input](#)
- [Set up the API referral application](#)
- [Set up concentration measurement](#)
- [Set up flow rate measurement](#)

4.1 Verify the calibration factors

Display	<i>Not available</i>
ProLink III	Device Tools > Calibration Data
Field Communicator	Configure > Manual Setup > Calibration Factors

Overview

The calibration factors are used to adjust measurement for the unique traits of the sensor. Your device was calibrated at the factory. However, you should verify that the calibration factors that are configured in your device match the factory values.

Prerequisites

You will need the factory values for the calibration factors. These are provided in two locations:

- The calibration certificate shipped with your meter
- The label inside the transmitter's end-cap

Important

If the transmitter is not the original component, do not use the values from the transmitter label.

Procedure

1. View the calibration factors that are stored in the device.
2. Compare them to the factory values.
 - If the values match, no action is required.
 - If the values do not match, contact Micro Motion customer service.

Related information

[Sample calibration certificate](#)

4.1.1 Calibration factors

The original calibration factors are obtained from factory calibration, and are unique to each device. They are used to adjust measurements for the specific physical properties of the device.

The calibration certificate contains two sets of factors:

Density calibration coefficients	Define the relationship between density and the response of your sensor
Temperature compensation coefficients	Adjust density measurement for the effect of temperature on sensor response

The calibration certificate also provides the results of the Known Density Verification procedure that was performed at the factory.

For each calibration performed at the factory, the calibration certificate contains the data used to calculate the calibration coefficients.

Related information

[Sample calibration certificate](#)

4.2 Configure line density measurement

The density measurement parameters control how density is measured and reported.

- [Configure Density Measurement Unit](#) (Section 4.2.1)
- [Configure Density Damping](#) (Section 4.2.2)
- [Configure Density Cutoff](#) (Section 4.2.3)
- [Configure two-phase flow parameters](#) (Section 4.2.4)

4.2.1 Configure Density Measurement Unit

Display	OFF-LINE MAINT > OFF-LINE CONFIG > UNITS > DENS
ProLink III	Device Tools > Configuration > Process Measurement > Line Density > Density Unit
Field Communicator	Configure > Manual Setup > Measurements > Density > Density Unit

Overview

Density Measurement Unit controls the measurement units that will be used in density calculations and reporting.

Restriction

If the API referral application is enabled, you cannot change the density measurement unit here. The density measurement unit is controlled by the API table selection.

Procedure

Set Density Measurement Unit to the option you want to use.

The default setting for Density Measurement Unit is g/cm³ (grams per cubic centimeter).

Related information

[Set up the API referral application](#)

Options for Density Measurement Unit

The transmitter provides a standard set of measurement units for Density Measurement Unit. Different communications tools may use different labels.

Table 4-1: Options for Density Measurement Unit

Unit description	Label		
	Display (standard)	ProLink III	Field Communicator
Specific gravity	SGU	SGU	SGU
Grams per cubic centimeter	G/CM3	g/cm3	g/Cucm
Grams per liter	G/L	g/l	g/L
Grams per milliliter	G/mL	g/ml	g/mL
Kilograms per liter	KG/L	kg/l	kg/L
Kilograms per cubic meter	KG/M3	kg/m3	kg/Cum
Pounds per U.S. gallon	LB/GAL	lbs/Usgal	lb/gal
Pounds per cubic foot	LB/CUF	lbs/ft3	lb/Cuft
Pounds per cubic inch	LB/CUI	lbs/in3	lb/CuIn
Short ton per cubic yard	ST/CUY	sT/yd3	STon/Cuyd
Degrees API	D API	degAPI	degAPI
Special unit	SPECL	special	Spcl

Define a special measurement unit for density

Display	<i>Not available</i>
ProLink III	Device Tools > Configuration > Process Measurement > Line Density > Special Units
Field Communicator	Configure > Manual Setup > Measurements > Special Units

Overview

A special measurement unit is a user-defined unit of measure that allows you to report process data in a unit that is not available in the transmitter. A special measurement unit is calculated from an existing measurement unit using a conversion factor.

Procedure

1. Specify Density Special Unit Base.
Density Special Unit Base is the existing density unit that the special unit will be based on.
2. Calculate Density Special Unit Conversion Factor as follows:
 - a. $x \text{ base units} = y \text{ special units}$
 - b. $\text{Density Special Unit Conversion Factor} = x \div y$
3. Enter Density Special Unit Conversion Factor.
The original density value is divided by this conversion factor.
4. Set User-Defined Label to the name you want to use for the density unit.

The special measurement unit is stored in the transmitter. You can configure the transmitter to use the special measurement unit at any time.

Example: Defining a special measurement unit for density

You want to measure density in ounces per cubic inch.

1. Set Density Special Unit Base to g/cm³.
2. Calculate Density Special Unit Conversion Factor:
 - a. $1 \text{ g/cm}^3 = 0.578 \text{ oz/in}^3$
 - b. $1 \div 0.578 = 1.73$
3. Set Density Special Unit Conversion Factor to 1.73.
4. Set User-Defined Label to oz/in³.

4.2.2 Configure Density Damping

Display	<i>Not available</i>
ProLink III	Device Tools > Configuration > Process Measurement > Line Density > Density Damping
Field Communicator	Configure > Manual Setup > Measurements > Density > Density Damping

Overview

Density Damping controls the amount of damping that will be applied to the line density value.

Damping is used to smooth out small, rapid fluctuations in process measurement. Damping Value specifies the time period (in seconds) over which the transmitter will spread changes in the process variable. At the end of the interval, the internal value will reflect 63% of the change in the actual measured value.

Tip

Density damping affects all process variables that are calculated from line density.

Procedure

Set Density Damping to the value you want to use.

The default value is 1.6 seconds. The range is 0 to 60 seconds.

Interaction between Density Damping and Added Damping

When the mA output is configured to report density, both Density Damping and Added Damping are applied to the reported density value.

Density Damping controls the rate of change in the value of the process variable in transmitter memory. Added Damping controls the rate of change reported via the mA output.

If mA Output Process Variable is set to Density, and both Density Damping and Added Damping are set to non-zero values, density damping is applied first, and the added damping calculation is applied to the result of the first calculation. This value is reported over the mA output.

Related information

[Interaction between mA Output Damping and process variable damping](#)

4.2.3 Configure Density Cutoff

Display	<i>Not available</i>
ProLink III	Device Tools > Configuration > Process Measurement > Line Density > Density Cutoff Low
Field Communicator	Configure > Manual Setup > Measurements > Density > Density Cutoff

Overview

Density Cutoff Low specifies the lowest density value that will be reported as measured. All density values below this cutoff will be reported as 0.

Procedure

Set Density Cutoff Low to the value you want to use.

The default value is 0.2 g/cm³. The range is 0.0 g/cm³ to 0.5 g/cm³.

4.2.4 Configure two-phase flow parameters

Display	<i>Not available</i>
ProLink III	Device Tools > Configuration > Process Measurement > Line Density
Field Communicator	Configure > Manual Setup > Measurements > Density

Overview

The two-phase flow parameters control how the transmitter detects and reports two-phase flow (gas in a liquid process or liquid in a gas process).

Note

Two-phase flow is sometimes referred to as *slug flow*.

Procedure

1. Set Two-Phase Flow Low Limit to the lowest density value that is considered normal in your process.

Values below this will cause the transmitter to post Alert A105 (Two-Phase Flow).

Tip

Gas entrainment can cause your process density to drop temporarily. To reduce the occurrence of two-phase flow alerts that are not significant to your process, set Two-Phase Flow Low Limit slightly below your expected lowest process density.

You must enter Two-Phase Flow Low Limit in g/cm^3 , even if you configured another unit for density measurement.

2. Set Two-Phase Flow High Limit to the highest density value that is considered normal in your process.

Values above this will cause the transmitter to post Alert A105 (Two-Phase Flow).

Tip

To reduce the occurrence of two-phase flow alerts that are not significant to your process, set Two-Phase Flow High Limit slightly above your expected highest process density.

You must enter Two-Phase Flow High Limit in g/cm^3 , even if you configured another unit for density measurement.

3. Set Two-Phase Flow Timeout to the number of seconds that the transmitter will wait for a two-phase flow condition to clear before posting the alert.

The default value for Two-Phase Flow Timeout is 0.0 seconds, meaning that the alert will be posted immediately. The range is 0.0 to 60.0 seconds.

Detecting and reporting two-phase flow

Two-phase flow (gas in a liquid process or liquid in a gas process) can cause a variety of process control issues. By configuring the two-phase flow parameters appropriately for your application, you can detect process conditions that require correction.

Tip

To decrease the occurrence of two-phase flow alerts, lower Two-Phase Flow Low Limit or raise Two-Phase Flow High Limit.

A two-phase flow condition occurs whenever the measured density goes below Two-Phase Flow Low Limit or above Two-Phase Flow High Limit. If this occurs:

- A two-phase flow alert is posted to the active alert log.
- Line density is held at its last *pre-alert* value for the number of seconds configured in Two-Phase Flow Timeout.

If the two-phase flow condition clears before Two-Phase Flow Timeout expires:

- Line density reverts to actual process density.
- The two-phase flow alert is deactivated, but remains in the active alert log until it is acknowledged.

If the two-phase flow condition does not clear before Two-Phase Flow Timeout expires, line density reverts to actual process density, but the two-phase flow alert remains active.

If Two-Phase Flow Timeout is set to 0.0 seconds, two-phase flow will cause a two-phase flow alert but will have no effect on how the meter measures or reports line density.

4.3 Configure temperature measurement

The temperature measurement parameters control how temperature data from the sensor is reported.

- [Configure Temperature Measurement Unit](#) (Section 4.3.1)
- [Configure Temperature Damping](#) (Section 4.3.2)
- [Configure Temperature Input](#) (Section 4.3.3)

4.3.1 Configure Temperature Measurement Unit

Display	OFF-LINE MAINT > OFF-LINE CONFIG > UNITS > TEMP
ProLink III	Device Tools > Configuration > Process Measurement > Line Temperature > Temperature Unit
Field Communicator	Configure > Manual Setup > Measurements > Temperature > Temperature Unit

Overview

Temperature Measurement Unit specifies the unit that will be used for temperature measurement.

Restriction

If the API referral application is enabled, the API table selection automatically sets the temperature measurement unit. Configure the API referral application first, then change the temperature measurement unit if desired.

Procedure

Set Temperature Measurement Unit to the option you want to use.

The default setting is Degrees Celsius.

Related information

[Set up the API referral application](#)

Options for Temperature Measurement Unit

The transmitter provides a standard set of units for Temperature Measurement Unit. Different communications tools may use different labels for the units.

Table 4-2: Options for Temperature Measurement Unit

Unit description	Label		
	Display	ProLink III	Field Communicator
Degrees Celsius	°C	°C	degC
Degrees Fahrenheit	°F	°F	degF
Degrees Rankine	°R	°R	degR
Kelvin	°K	°K	Kelvin

4.3.2 Configure Temperature Damping

Display	<i>Not available</i>
ProLink III	Device Tools > Configuration > Process Measurement > Line Temperature > Temperature Damping
Field Communicator	Configure > Manual Setup > Measurements > Temperature > Temp Damping

Overview

Temperature Damping controls the amount of damping that will be applied to the line temperature value, when the on-board temperature data is used (RTD).

Damping is used to smooth out small, rapid fluctuations in process measurement. Damping Value specifies the time period (in seconds) over which the transmitter will spread changes in the process variable. At the end of the interval, the internal value will reflect 63% of the change in the actual measured value.

Tip

Temperature Damping affects all process variables, compensations, and corrections that use temperature data from the sensor.

Procedure

Enter the value you want to use for Temperature Damping.

- Default: 4.8 seconds
-

Tips

- A high damping value makes the process variable appear smoother because the reported value changes slowly.
 - A low damping value makes the process variable appear more erratic because the reported value changes more quickly.
 - Whenever the damping value is non-zero, the reported measurement will lag the actual measurement because the reported value is being averaged over time.
 - In general, lower damping values are preferable because there is less chance of data loss, and less lag time between the actual measurement and the reported value.
-

The value you enter is automatically rounded down to the nearest valid value.

4.3.3 Configure Temperature Input

Temperature data from the on-board temperature sensor (RTD) is always available. Optionally, you can set up an external temperature device and use external temperature data.

Tip

Use an external device only if it is more accurate than the internal RTD.

Important

Line temperature data is used in several different measurements and calculations. It is possible to use the internal RTD temperature in some areas and an external temperature in others. The transmitter stores the internal RTD temperature and the external temperature separately. However, the transmitter stores only one alternate temperature value, which may be either an external temperature or the configured fixed value. Accordingly, if you set up polling for temperature in one area, and digital communications in another, and configure a fixed temperature value in a third, the fixed value will be overwritten by polling and digital communications, and polling and digital communications will overwrite each other.

- [Configure Temperature Input using ProLink III](#)
- [Configure Temperature Input using the Field Communicator](#)

Configure Temperature Input using ProLink III

ProLink III	Device Tools > Configuration > Process Measurement > Line Temperature > Line Temperature Source
-------------	---

Procedure

Choose the method to be used to supply temperature data, and perform the required setup.

Option	Description	Setup						
Internal RTD temperature data	Temperature data from the on-board temperature sensor (RTD) is used.	<ol style="list-style-type: none"> Set Line Temperature Source to Internal RTD. Click Apply. 						
Polling	The meter polls an external device for temperature data. This data will be available in addition to the internal RTD temperature data.	<ol style="list-style-type: none"> Set Line Temperature Source to Poll for External Value. Set Polling Slot to an available slot. Set Polling Control to Poll as Primary or Poll as Secondary. 						
		<table border="1"> <thead> <tr> <th>Option</th> <th>Description</th> </tr> </thead> <tbody> <tr> <td>Poll as Primary</td> <td>No other HART masters will be on the network. The Field Communicator is not a HART master.</td> </tr> <tr> <td>Poll as Secondary</td> <td>Other HART masters will be on the network. The Field Communicator is not a HART master.</td> </tr> </tbody> </table>	Option	Description	Poll as Primary	No other HART masters will be on the network. The Field Communicator is not a HART master.	Poll as Secondary	Other HART masters will be on the network. The Field Communicator is not a HART master.
		Option	Description					
		Poll as Primary	No other HART masters will be on the network. The Field Communicator is not a HART master.					
Poll as Secondary	Other HART masters will be on the network. The Field Communicator is not a HART master.							
<ol style="list-style-type: none"> Set External Device Tag to the HART tag of the temperature device. Click Apply. 								
Digital communications	A host writes temperature data to the meter at appropriate intervals. This data will be available in addition to the internal RTD temperature data.	<ol style="list-style-type: none"> Set Line Temperature Source to Fixed Value or Digital Communications. Click Apply. Perform the necessary host programming and communications setup to write temperature data to the meter at appropriate intervals. 						

Postrequisites

If you are using external temperature data, verify the external temperature value displayed in the Inputs group on the ProLink III main window.

Need help? If the value is not correct:

- For polling:
 - Verify the wiring between the meter and the external device.
 - Verify the HART tag of the external device.
- For digital communications:
 - Verify that the host has access to the required data.
 - Verify that the host is writing to the correct register in memory, using the correct data type.

Configure Temperature Input using the Field Communicator

Choose the method to be used to supply temperature data, and perform the required setup.

Method	Description	Setup						
Internal RTD temperature data	Temperature data from the on-board temperature sensor (RTD) is used.	a. Choose Configure > Manual Setup > Measurements > External Inputs > Temperature. b. Set External Temperature to Disable.						
Polling	The meter polls an external device for temperature data. This data will be available in addition to the internal RTD temperature data.	a. Choose Configure > Manual Setup > Measurements > External Inputs > Temperature. b. Set External Temperature to Enable. c. Choose Configure > Manual Setup > Inputs/Outputs > External Device Polling. d. Choose an unused polling slot. e. Set Poll Control to Poll as Primary or Poll as Secondary.						
		<table border="1"> <thead> <tr> <th>Option</th> <th>Description</th> </tr> </thead> <tbody> <tr> <td>Poll as Primary</td> <td>No other HART masters will be on the network. The Field Communicator is not a HART master.</td> </tr> <tr> <td>Poll as Secondary</td> <td>Other HART masters will be on the network. The Field Communicator is not a HART master.</td> </tr> </tbody> </table>	Option	Description	Poll as Primary	No other HART masters will be on the network. The Field Communicator is not a HART master.	Poll as Secondary	Other HART masters will be on the network. The Field Communicator is not a HART master.
Option	Description							
Poll as Primary	No other HART masters will be on the network. The Field Communicator is not a HART master.							
Poll as Secondary	Other HART masters will be on the network. The Field Communicator is not a HART master.							
		f. Set External Device Tag to the HART tag of the external temperature device. g. Set Polled Variable to Temperature.						
Digital communications	A host writes temperature data to the meter at appropriate intervals. This data will be available in addition to the internal RTD temperature data.	a. Choose Configure > Manual Setup > Measurements > External Inputs > Temperature. b. Set External Temperature to Enable. c. Perform the necessary host programming and communications setup to write temperature data to the meter at appropriate intervals.						

Postrequisites

Choose Service Tools > Variables > External Variables and verify the value for External Temperature.

Need help? If the value is not correct:

- Ensure that the external device and the meter are using the same measurement unit.
- For polling:
 - Verify the wiring between the meter and the external device.
 - Verify the HART tag of the external device.
- For digital communications:
 - Verify that the host has access to the required data.
 - Verify that the host is writing to the correct register in memory, using the correct data type.
- If necessary, apply an offset.

4.4 Configure the pressure input

Pressure data is required to calculate base density from line density.

- The meter does not measure pressure, so you must provide an external pressure input.
- You must use absolute pressure.
- Pressure data is required for several different measurements.
- There are several different methods to obtain pressure data.

Tip

A fixed pressure value is not recommended as it can produce inaccurate process data.

- [Configure the pressure input using ProLink III](#) (Section 4.4.1)
- [Configure the pressure input using the Field Communicator](#) (Section 4.4.2)

4.4.1 Configure the pressure input using ProLink III

1. Choose Device Tools > Configuration > Process Measurement > Line Pressure.
2. Set Pressure Type to match the pressure measurement from the external pressure device.

Option	Description
Absolute	The external pressure device reports absolute pressure.
Gauge	The external pressure device reports gauge pressure.

Restriction

If Line Pressure Source is set to Fixed, you cannot configure Pressure Type. You must enter the pressure value in the required form. To set Pressure Type, you may need to change the setting of Line Pressure Source.

The meter requires gauge pressure. If you select Absolute, the device will convert the input pressure value to the equivalent gauge pressure.

3. Set Pressure Unit to the unit used by the external pressure device.

Restriction

If the API referral application is enabled, the API table selection automatically sets the pressure measurement unit. Configure the API referral application first, then change the pressure measurement unit if necessary.

4. Choose the method used to supply pressure data and perform the required setup.

Option	Description	Setup						
Polling	The meter polls an external device for pressure data.	<ol style="list-style-type: none"> a. Set Pressure Source to Poll for External Value. b. Set Polling Slot to an available slot. c. Set Polling Control to Poll as Primary or Poll as Secondary. 						
		<table border="1"> <thead> <tr> <th>Option</th> <th>Description</th> </tr> </thead> <tbody> <tr> <td>Poll as Primary</td> <td>No other HART masters will be on the network. The Field Communicator is not a HART master.</td> </tr> <tr> <td>Poll as Secondary</td> <td>Other HART masters will be on the network. The Field Communicator is not a HART master.</td> </tr> </tbody> </table>	Option	Description	Poll as Primary	No other HART masters will be on the network. The Field Communicator is not a HART master.	Poll as Secondary	Other HART masters will be on the network. The Field Communicator is not a HART master.
		Option	Description					
		Poll as Primary	No other HART masters will be on the network. The Field Communicator is not a HART master.					
Poll as Secondary	Other HART masters will be on the network. The Field Communicator is not a HART master.							
<ol style="list-style-type: none"> d. Set External Device Tag to the HART tag of the temperature device. 								
Digital communications	A host writes pressure data to the meter at appropriate intervals.	<ol style="list-style-type: none"> a. Set Pressure Source to Fixed Value or Digital Communications. b. Perform the necessary host programming and communications setup to write pressure data to the meter at appropriate intervals. 						

Postrequisites

The current pressure value is displayed in the External Pressure field. Verify that the value is correct.

Need help? If the value is not correct:

- Ensure that the external device and the meter are using the same measurement unit.
- For polling:
 - Verify the wiring between the meter and the external device.

- Verify the HART tag of the external device.
- For digital communications:
 - Verify that the host has access to the required data.
 - Verify that the host is writing to the correct register in memory, using the correct data type.
- If necessary, apply an offset.

Note

Do not use the offset in conjunction with the fixed pressure value. Enter the adjusted value.

Related information

[Set up the API referral application](#)

4.4.2 Configure the pressure input using the Field Communicator

1. Choose Configure > Manual Setup > Measurements > External Inputs > Pressure.
2. Set Pressure Input to Enable.
3. Set Pressure Type to match the pressure measurement from the external pressure device.

Option	Description
Absolute	The external pressure device reports absolute pressure.
Gauge	The external pressure device reports gauge pressure.

Restriction

If Line Pressure Source is set to Fixed, you cannot configure Pressure Type. You must enter the pressure value in the required form. To set Pressure Type, you may need to change the setting of Line Pressure Source.

The meter requires gauge pressure. If you select Absolute, the device will convert the input pressure value to the equivalent gauge pressure.

4. Set Pressure Unit to the unit used by the external pressure device.

Restriction

If the API referral application is enabled, the API table selection automatically sets the pressure measurement unit. Configure the API referral application first, then change the pressure measurement unit if necessary.

5. Set up the pressure input.
 - a. Choose Configure > Manual Setup > Inputs/Outputs > External Device Polling.
 - b. Choose an unused polling slot.

- c. Set Polling Control to Poll as Primary or Poll as Secondary.

Option	Description
Poll as Primary	No other HART masters will be on the network. The Field Communicator is not a HART master.
Poll as Secondary	Other HART masters will be on the network. The Field Communicator is not a HART master.

- d. Set External Device Tag to the HART tag of the external pressure device.
e. Set Polled Variable to Pressure.

Postrequisites

Choose Service Tools > Variables > External Variables and verify the value for External Pressure.

Need help? If the value is not correct:

- Ensure that the external device and the meter are using the same measurement unit.
- For polling:
 - Verify the wiring between the meter and the external device.
 - Verify the HART tag of the external device.
- For digital communications:
 - Verify that the host has access to the required data.
 - Verify that the host is writing to the correct register in memory, using the correct data type.
- If necessary, apply an offset.

Related information

[Set up the API referral application](#)

4.4.3 Options for Pressure Measurement Unit

The transmitter provides a standard set of measurement units for Pressure Measurement Unit. Different communications tools may use different labels for the units. In most applications, Pressure Measurement Unit should be set to match the pressure measurement unit used by the remote device.

Table 4-3: Options for Pressure Measurement Unit

Unit description	Label		
	Display	ProLink III	Field Communicator
Feet water @ 68 °F	FTH2O	Ft Water @ 68°F	ftH2O
Inches water @ 4 °C	INW4C	In Water @ 4°C	inH2O @4DegC
Inches water @ 60 °F	INW60	In Water @ 60°F	inH2O @60DegF

Table 4-3: Options for Pressure Measurement Unit (continued)

Unit description	Label		
	Display	ProLink III	Field Communicator
Inches water @ 68 °F	INH2O	In Water @ 68°F	inH2O
Millimeters water @ 4 °C	mmW4C	mm Water @ 4°C	mmH2O @4DegC
Millimeters water @ 68 °F	mmH2O	mm Water @ 68°F	mmH2O
Millimeters mercury @ 0 °C	mmHG	mm Mercury @ 0°C	mmHg
Inches mercury @ 0 °C	INHG	In Mercury @ 0°C	inHG
Pounds per square inch	PSI	PSI	psi
Bar	BAR	bar	bar
Millibar	mBAR	millibar	mbar
Grams per square centimeter	G/SCM	g/cm2	g/Sqcm
Kilograms per square centimeter	KG/SCM	kg/cm2	kg/Sqcm
Pascals	PA	pascals	Pa
Kilopascals	KPA	Kilopascals	kPa
Megapascals	MPA	Megapascals	MPa
Torr @ 0 °C	TORR	Torr @ 0°C	torr
Atmospheres	ATM	atms	atms

4.5 Set up the API referral application

The API referral application corrects line density to reference temperature and reference pressure according to American Petroleum Institute (API) standards. The resulting process variable is *referred density*.

- [Set up the API referral application using ProLink III](#) (Section 4.5.1)
- [Set up the API referral application using the Field Communicator](#) (Section 4.5.2)

4.5.1 Set up the API referral application using ProLink III

This section guides you through the tasks required to set up and implement the API referral application.

1. [Enable the API referral application using ProLink III](#)
2. [Configure API referral using ProLink III](#)
3. [Set up temperature and pressure data for API referral using ProLink III](#)

Enable the API referral application using ProLink III

The API referral application must be enabled before you can perform any setup. If the API referral application was enabled at the factory, you do not need to enable it now.

1. Choose Device Tools > Configuration > Transmitter Options.
2. If the concentration measurement application is enabled, disable it and click Apply.

The concentration measurement application and the API referral application cannot be enabled simultaneously.
3. Enable API Referral and click Apply.

Configure API referral using ProLink III

The API referral parameters specify the API table, measurement units, and reference values to be used in referred density calculations.

Prerequisites

You will need API documentation for the API table that you select.

Depending on your API table, you may need to know the thermal expansion coefficient (TEC) for your process fluid.

You must know the reference temperature and reference pressure that you want to use.

Procedure

1. Choose Device Tools > Configuration > Process Measurement > API Referral.
2. Specify the API table to use.

Each API table is associated with a specific set of equations.

- a. Set Process Fluid to the API table group that your process fluid belongs to.

API table group	Process fluids
A tables	Generalized crude and JP4
B tables	Generalized products: Gasoline, jet fuel, aviation fuel, kerosene, heating oils, fuel oils, diesel, gas oil
C tables	Liquids with a constant base density or known thermal expansion coefficient (TEC). You will be required to enter the TEC for your process fluid.
D tables	Lubricating oils
E tables	NGL (Natural Gas Liquids) and LPG (Liquid Petroleum Gas)

Restriction

The API referral application is not appropriate for the following process fluids: propane and propane mixes, butane and butane mixes, butadiene and butadiene mixes, isopentane, LNG, ethylene, propylene, cyclohexane, aromatics, asphalts, and road tars.

- b. Set Referred Density Measurement Unit to the measurement units that you want to use for referred density.
- c. Click Apply.

These parameters uniquely identify the API table. The selected API table is displayed, and the meter automatically changes the density unit, temperature unit, pressure unit, reference temperature, and reference pressure to match the API table.

Restriction

Not all combinations are supported by the API referral application. See the list of API tables in this manual.

3. Refer to the API documentation and confirm your table selection.
 - a. Verify that your process fluid falls within range for line density, line temperature, and line pressure.

If your process fluid goes outside any of these limits, the meter will post a status alert and will report line density instead of referred density until the process fluid goes back within range.
 - b. Verify that the referred density range of the selected table is adequate for your application.
4. If you chose a C table, enter Thermal Expansion Coefficient (TEC) for your process fluid.
5. Set Reference Temperature to the temperature to which density will be corrected in referred density calculations. If you choose Other, select the temperature measurement unit and enter the reference temperature.
6. Set Reference Pressure to the pressure to which density will be corrected in referred density calculations.

API tables supported by the API referral application

The API tables listed here are supported by the API referral application.

Table 4-4: API tables, process fluids, measurement units, and default reference values

Process fluid	API table	Referred density (API)	Default reference temperature	Default reference pressure
Generalized crude and JP4	5A	Unit: °API Range: 0 to 100 °API	60 °F	0 psi (g)
	23A	Unit: SGU Range: 0.6110 to 1.0760 SGU	60 °F	0 psi (g)
	53A	Unit: kg/m ³ Range: 610 to 1075 kg/m ³	15 °C	0 kPa (g)
Generalized products (gasoline, jet fuel, aviation fuel, kerosene, heating oils, fuel oils, diesel, gas oil)	5B	Unit: °API Range: 0 to 85 °API	60 °F	0 psi (g)
	23B	Unit: SGU Range: 0.6535 to 1.0760 SGU	60 °F	0 psi (g)

Table 4-4: API tables, process fluids, measurement units, and default reference values (continued)

Process fluid	API table	Referred density (API)	Default reference temperature	Default reference pressure
	53B	Unit: kg/m ³ Range: 653 to 1075 kg/m ³	15 °C	0 kPa (g)
Liquids with a constant density base or known thermal expansion coefficient	6C	Unit: °API	60 °F	0 psi (g)
	24C	Unit: SGU	60 °F	0 psi (g)
	54C	Unit: kg/m ³	15 °C	0 kPa (g)
Lubricating oils	5D	Unit: °API Range: -10 to +40 °API	60 °F	0 psi (g)
	23D	Unit: SGU Range: 0.8520 to 1.1640 SGU	60 °F	0 psi (g)
	53D	Unit: kg/m ³ Range: 825 to 1164 kg/m ³	15 °C	0 kPa (g)
NGL (natural gas liquids)	23E	Unit: SGU	60 °F	0 psi (g)
LPG (liquid petroleum gas)	24E	Unit: SGU	60 °F	0 psi (g)

Restriction

These tables are not appropriate for the following process fluids: propane and propane mixes, butane and butane mixes, butadiene and butadiene mixes, isopentane, LNG, ethylene, propylene, cyclohexane, aromatics, asphalts, and road tars.

Set up temperature and pressure data for API referral using ProLink III

The API referral application uses temperature and, optionally, pressure data in its calculations. You must decide how to provide this data, then perform the required configuration and setup.

Tip

Fixed values for temperature or pressure are not recommended. Using a fixed temperature or pressure value may produce inaccurate process data.

Important

Line temperature data is used in several different measurements and calculations. It is possible to use the internal RTD temperature in some areas and an external temperature in others. The transmitter stores the internal RTD temperature and the external temperature separately. However, the transmitter stores only one alternate temperature value, which may be either an external temperature or the configured fixed value. Accordingly, if you set up polling for temperature in one area, and digital communications in another, and configure a fixed temperature value in a third, the fixed value will be overwritten by polling and digital communications, and polling and digital communications will overwrite each other.

Important

Line pressure data is used in several different measurements and calculations. The transmitter stores only one pressure value, which may be either the external pressure or the configured fixed value. Accordingly, if you choose a fixed pressure for some uses, and an external pressure for others, the external pressure will overwrite the fixed value.

Prerequisites

- If you plan to poll an external device, the primary mA output (Channel A) must be wired to support HART communications.
- The pressure measurement must be gauge pressure, not atmospheric pressure. If your pressure input is absolute, you can set the pressure type to absolute and it will be converted to gauge for the API calculations.
- The pressure device must use the pressure unit that is configured in the transmitter.
- If you are using an external temperature device, it must use the temperature unit that is configured in the transmitter.

Procedure

1. Choose Device Tools > Configuration > Process Measurement > API Referral.
2. Choose the method to be used to supply temperature data, and perform the required setup.

Option	Description	Setup						
Internal RTD temperature data	Temperature data from the on-board temperature sensor (RTD) is used.	<ol style="list-style-type: none"> a. Set Line Temperature Source to Internal RTD. b. Click Apply. 						
Polling	The meter polls an external device for temperature data. This data will be available in addition to the internal RTD temperature data.	<ol style="list-style-type: none"> a. Set Line Temperature Source to Poll for External Value. b. Set Polling Slot to an available slot. c. Set Polling Control to Poll as Primary or Poll as Secondary. 						
		<table border="1"> <thead> <tr> <th>Option</th> <th>Description</th> </tr> </thead> <tbody> <tr> <td>Poll as Primary</td> <td>No other HART masters will be on the network. The Field Communicator is not a HART master.</td> </tr> <tr> <td>Poll as Secondary</td> <td>Other HART masters will be on the network. The Field Communicator is not a HART master.</td> </tr> </tbody> </table>	Option	Description	Poll as Primary	No other HART masters will be on the network. The Field Communicator is not a HART master.	Poll as Secondary	Other HART masters will be on the network. The Field Communicator is not a HART master.
		Option	Description					
		Poll as Primary	No other HART masters will be on the network. The Field Communicator is not a HART master.					
Poll as Secondary	Other HART masters will be on the network. The Field Communicator is not a HART master.							
<ol style="list-style-type: none"> d. Set External Device Tag to the HART tag of the temperature device. e. Click Apply. 								

Option	Description	Setup
Digital communications	A host writes temperature data to the meter at appropriate intervals. This data will be available in addition to the internal RTD temperature data.	<ol style="list-style-type: none"> Set Line Temperature Source to Fixed Value or Digital Communications. Click Apply. Perform the necessary host programming and communications setup to write temperature data to the meter at appropriate intervals.

3. Choose the method used to supply pressure data and perform the required setup.

Option	Description	Setup						
Polling	The meter polls an external device for pressure data.	<ol style="list-style-type: none"> Set Pressure Source to Poll for External Value. Set Polling Slot to an available slot. Set Polling Control to Poll as Primary or Poll as Secondary. 						
		<table border="1"> <thead> <tr> <th>Option</th> <th>Description</th> </tr> </thead> <tbody> <tr> <td>Poll as Primary</td> <td>No other HART masters will be on the network. The Field Communicator is not a HART master.</td> </tr> <tr> <td>Poll as Secondary</td> <td>Other HART masters will be on the network. The Field Communicator is not a HART master.</td> </tr> </tbody> </table>	Option	Description	Poll as Primary	No other HART masters will be on the network. The Field Communicator is not a HART master.	Poll as Secondary	Other HART masters will be on the network. The Field Communicator is not a HART master.
		Option	Description					
		Poll as Primary	No other HART masters will be on the network. The Field Communicator is not a HART master.					
Poll as Secondary	Other HART masters will be on the network. The Field Communicator is not a HART master.							
<ol style="list-style-type: none"> Set External Device Tag to the HART tag of the temperature device. 								
Digital communications	A host writes pressure data to the meter at appropriate intervals.	<ol style="list-style-type: none"> Set Pressure Source to Fixed Value or Digital Communications. Perform the necessary host programming and communications setup to write pressure data to the meter at appropriate intervals. 						

Postrequisites

If you are using external temperature data, verify the external temperature value displayed in the Inputs group on the ProLink III main window.

The current pressure value is displayed in the External Pressure field. Verify that the value is correct.

Need help? If the value is not correct:

- Ensure that the external device and the meter are using the same measurement unit.
- For polling:
 - Verify the wiring between the meter and the external device.
 - Verify the HART tag of the external device.
- For digital communications:
 - Verify that the host has access to the required data.

- Verify that the host is writing to the correct register in memory, using the correct data type.
- If necessary, apply an offset.

4.5.2 Set up the API referral application using the Field Communicator

This section guides you through the tasks required to set up and implement the API referral application.

1. [Enable the API referral application using the Field Communicator](#)
2. [Configure API referral using the Field Communicator](#)
3. [Set up temperature and pressure data for API referral using the Field Communicator](#)

Enable the API referral application using the Field Communicator

The API referral application must be enabled before you can perform any setup. If the API referral application was enabled at the factory, you do not need to enable it now.

1. Choose Overview > Device Information > Applications > Enable/Disable Applications.
2. If the concentration measurement application is enabled, disable it.

The concentration measurement application and the API referral application cannot be enabled simultaneously.

3. Enable the API referral application.

Configure API referral using the Field Communicator

The API referral parameters specify the API table, measurement units, and reference values to be used in referred density calculations.

Prerequisites

You will need API documentation for the API table that you select.

Depending on your API table, you may need to know the thermal expansion coefficient (TEC) for your process fluid.

You must know the reference temperature and reference pressure that you want to use.

Procedure

1. Choose Configure > Manual Setup > Measurements > API Referral.
2. Choose API Referral Setup.
3. Specify the API table that you want to use for measurement.

Each API table is associated with a specific set of equations.

- a. Set API Table Number to the number that matches the API table units that you want to use for referred density.

Your choice also determines the measurement units to be used for temperature and pressure, and the default values for reference temperature and reference pressure.

API Table Number	Measurement unit for referred density	Temperature measurement unit	Pressure measurement unit	Default reference temperature	Default reference pressure
5	°API	°F	psi (g)	60 °F	0 psi (g)
6 ⁽¹⁾	°API	°F	psi (g)	60 °F	0 psi (g)
23	SGU	°F	psi (g)	60 °F	0 psi (g)
24 ⁽¹⁾	SGU	°F	psi (g)	60 °F	0 psi (g)
53	kg/m ³	°C	kPa (g)	15 °C	0 kPa (g)
54 ⁽¹⁾	kg/m ³	°C	kPa (g)	15 °C	0 kPa (g)

(1) Used only with API Table Letter = C.

- b. Set API Table Letter to the letter of the API table group that is appropriate for your process fluid.

API Table Letter	Process fluids
A	Generalized crude and JP4
B	Generalized products: Gasoline, jet fuel, aviation fuel, kerosene, heating oils, fuel oils, diesel, gas oil
C ⁽¹⁾	Liquids with a constant base density or known thermal expansion coefficient (TEC). You will be required to enter the TEC for your process fluid.
D	Lubricating oils
E	NGL (Natural Gas Liquids) and LPG (Liquid Petroleum Gas)

(1) Used only with API Table Number = 6, 24, or 54.

Restriction

The API referral application is not appropriate for the following process fluids: propane and propane mixes, butane and butane mixes, butadiene and butadiene mixes, isopentane, LNG, ethylene, propylene, cyclohexane, aromatics, asphalts, and road tars.

API Table Number and API Table Letter uniquely identify the API table. The selected API table is displayed, and the meter automatically changes the density unit, temperature unit, pressure unit, reference temperature, and reference pressure to match the API table.

Restriction

Not all combinations are supported by the API referral application. See the list of API tables in this manual.

4. If you chose a C table, enter Thermal Expansion Coefficient (TEC) for your process fluid.
5. Refer to the API documentation and confirm your table selection.
 - a. Verify that your process fluid falls within range for line density, line temperature, and line pressure.

If your process fluid goes outside any of these limits, the meter will post a status alert and will report line density instead of referred density until the process fluid goes back within range.
 - b. Verify that the referred density range of the selected table is adequate for your application.
6. If required, set Ref Temperature to the temperature to which density will be corrected in referred density calculations.

The default reference temperature is determined by the selected API table.

- a. Choose Service Tools > Maintenance > Modbus Data > Write Modbus Data.
 - b. Write the desired reference temperature to Registers 319–320, in the measurement unit required by the selected API table. Use 32-bit IEEE floating-point format.
7. If required, set Ref Pressure (Gauge) to the pressure to which density will be corrected in referred density calculations.

The default reference pressure is determined by the selected API table. API referral requires gauge pressure.

- a. Choose Service Tools > Maintenance > Modbus Data > Write Modbus Data.
- b. Write the desired reference pressure to Registers 4601–4602, in the measurement unit required by the selected API table. Use 32-bit IEEE floating-point format.

API tables supported by the API referral application

The API tables listed here are supported by the API referral application.

Table 4-5: API tables, process fluids, measurement units, and default reference values

Process fluid	API table	Referred density (API)	Default reference temperature	Default reference pressure
Generalized crude and JP4	5A	Unit: °API Range: 0 to 100 °API	60 °F	0 psi (g)
	23A	Unit: SGU Range: 0.6110 to 1.0760 SGU	60 °F	0 psi (g)
	53A	Unit: kg/m ³ Range: 610 to 1075 kg/m ³	15 °C	0 kPa (g)

Table 4-5: API tables, process fluids, measurement units, and default reference values (continued)

Process fluid	API table	Referred density (API)	Default reference temperature	Default reference pressure
Generalized products (gasoline, jet fuel, aviation fuel, kerosene, heating oils, fuel oils, diesel, gas oil)	5B	Unit: °API Range: 0 to 85 °API	60 °F	0 psi (g)
	23B	Unit: SGU Range: 0.6535 to 1.0760 SGU	60 °F	0 psi (g)
	53B	Unit: kg/m ³ Range: 653 to 1075 kg/m ³	15 °C	0 kPa (g)
Liquids with a constant density base or known thermal expansion coefficient	6C	Unit: °API	60 °F	0 psi (g)
	24C	Unit: SGU	60 °F	0 psi (g)
	54C	Unit: kg/m ³	15 °C	0 kPa (g)
Lubricating oils	5D	Unit: °API Range: -10 to +40 °API	60 °F	0 psi (g)
	23D	Unit: SGU Range: 0.8520 to 1.1640 SGU	60 °F	0 psi (g)
	53D	Unit: kg/m ³ Range: 825 to 1164 kg/m ³	15 °C	0 kPa (g)
NGL (natural gas liquids)	23E	Unit: SGU	60 °F	0 psi (g)
LPG (liquid petroleum gas)	24E	Unit: SGU	60 °F	0 psi (g)

Restriction

These tables are not appropriate for the following process fluids: propane and propane mixes, butane and butane mixes, butadiene and butadiene mixes, isopentane, LNG, ethylene, propylene, cyclohexane, aromatics, asphalts, and road tars.

Set up temperature and pressure data for API referral using the Field Communicator

The API referral application uses temperature and, optionally, pressure data in its calculations. You must decide how to provide this data, then perform the required configuration and setup.

Tip

Fixed values for temperature or pressure are not recommended. Using a fixed temperature or pressure value may produce inaccurate process data.

Important

Line temperature data is used in several different measurements and calculations. It is possible to use the internal RTD temperature in some areas and an external temperature in others. The transmitter stores the internal RTD temperature and the external temperature separately. However, the transmitter stores only one alternate temperature value, which may be either an external temperature or the configured fixed value. Accordingly, if you set up polling for temperature in one area, and digital communications in another, and configure a fixed temperature value in a third, the fixed value will be overwritten by polling and digital communications, and polling and digital communications will overwrite each other.

Important

Line pressure data is used in several different measurements and calculations. The transmitter stores only one pressure value, which may be either the external pressure or the configured fixed value. Accordingly, if you choose a fixed pressure for some uses, and an external pressure for others, the external pressure will overwrite the fixed value.

Prerequisites

If you plan to poll an external device, the primary mA output (Channel A) must be wired to support HART communications.

The pressure measurement must be gauge pressure, not atmospheric pressure. If your pressure input is absolute, you can set the pressure type to absolute and it will be converted to gauge for the API calculations.

The pressure device must use the pressure unit that is configured in the transmitter.

If you are using an external temperature device, it must use the temperature unit that is configured in the transmitter.

Procedure

1. Choose the method to be used to supply temperature data, and perform the required setup.

Method	Description	Setup
Internal temperature	Temperature data from the on-board temperature sensor (RTD) will be used for all measurements and calculations. No external temperature data will be available.	<ol style="list-style-type: none"> a. Choose Configure > Manual Setup > Measurements > External Inputs > Temperature. b. Set External Temperature to Disable.

Method	Description	Setup						
Polling	The meter polls an external device for temperature data. This data will be available in addition to the internal temperature data.	<ul style="list-style-type: none"> a. Choose Configure > Manual Setup > Measurements > External Inputs > Temperature. b. Set External Temperature to Enable. c. Choose Configure > Manual Setup > Inputs/Outputs > External Device Polling. d. Choose an unused polling slot. e. Set Poll Control to Poll as Primary or Poll as Secondary. 						
		<table border="1"> <thead> <tr> <th>Option</th> <th>Description</th> </tr> </thead> <tbody> <tr> <td>Poll as Primary</td> <td>No other HART masters will be on the network. The Field Communicator is not a HART master.</td> </tr> <tr> <td>Poll as Secondary</td> <td>Other HART masters will be on the network. The Field Communicator is not a HART master.</td> </tr> </tbody> </table>	Option	Description	Poll as Primary	No other HART masters will be on the network. The Field Communicator is not a HART master.	Poll as Secondary	Other HART masters will be on the network. The Field Communicator is not a HART master.
		Option	Description					
Poll as Primary	No other HART masters will be on the network. The Field Communicator is not a HART master.							
Poll as Secondary	Other HART masters will be on the network. The Field Communicator is not a HART master.							
<ul style="list-style-type: none"> f. Set External Device Tag to the HART tag of the external temperature device. g. Set Polled Variable to Temperature. 								
Digital communications	A host writes temperature data to the meter at appropriate intervals. This data will be available in addition to the internal temperature data.	<ul style="list-style-type: none"> a. Choose Configure > Manual Setup > Measurements > External Inputs > Temperature. b. Set External Temperature to Enable. c. Perform the necessary host programming and communications setup to write temperature data to the transmitter at appropriate intervals. 						

2. Choose the method to be used to supply pressure data, and perform the required setup.

Method	Description	Setup						
Polling	The meter polls an external device for pressure data.	a. Choose Configure > Manual Setup > Measurements > External Inputs > Pressure. b. Set Pressure Input to Enable. c. Choose Configure > Manual Setup > Inputs/Outputs > External Device Polling. d. Choose an unused polling slot. e. Set Poll Control to Poll as Primary or Poll as Secondary.						
		<table border="1"> <thead> <tr> <th>Option</th> <th>Description</th> </tr> </thead> <tbody> <tr> <td>Poll as Primary</td> <td>No other HART masters will be on the network. The Field Communicator is not a HART master.</td> </tr> <tr> <td>Poll as Secondary</td> <td>Other HART masters will be on the network. The Field Communicator is not a HART master.</td> </tr> </tbody> </table>	Option	Description	Poll as Primary	No other HART masters will be on the network. The Field Communicator is not a HART master.	Poll as Secondary	Other HART masters will be on the network. The Field Communicator is not a HART master.
		Option	Description					
		Poll as Primary	No other HART masters will be on the network. The Field Communicator is not a HART master.					
Poll as Secondary	Other HART masters will be on the network. The Field Communicator is not a HART master.							
f. Set External Device Tag to the HART tag of the external pressure device. g. Set Polled Variable to Pressure.								
Digital communications	A host writes pressure data to the meter at appropriate intervals.	a. Choose Configure > Manual Setup > Measurements > External Inputs > Pressure. b. Set Pressure Input to Enable. c. Perform the necessary host programming and communications setup to write pressure data to the transmitter at appropriate intervals.						

Postrequisites

Choose Service Tools > Variables > External Variables and verify the values for External Temperature and External Pressure.

Need help? If the value is not correct:

- Ensure that the external device and the meter are using the same measurement unit.
- For polling:
 - Verify the wiring between the meter and the external device.
 - Verify the HART tag of the external device.
- For digital communications:
 - Verify that the host has access to the required data.
 - Verify that the host is writing to the correct register in memory, using the correct data type.
- If necessary, apply an offset.

4.6 Set up concentration measurement

The concentration measurement application calculates concentration from line density and line temperature.

Related information

[Preparing to set up concentration measurement](#)

[Set up concentration measurement using ProLink III](#)

[Set up concentration measurement using the Field Communicator](#)

4.6.1 Preparing to set up concentration measurement

The procedure for setting up concentration measurement application depends on how your device was ordered and how you want to use the application. Review this information before you begin.

Requirements for concentration measurement

To use the concentration measurement application, the following conditions must be met:

- The concentration measurement application must be enabled.
- One or more concentration matrices must be stored in your transmitter.

Tip

In most cases, the concentration matrix that you ordered was loaded at the factory. If you need to add concentration matrices and you are using ProLink III, you can load concentration matrices from a file or you can build a custom matrix. If you are using the Field Communicator, you can build a custom matrix but you cannot load a matrix from a file. This manual does not discuss building a custom matrix. For information on building a custom matrix, see *Micro Motion Enhanced Density Application: Theory, Configuration, and Use*.

- If your concentration matrices use Specific Gravity as the derived variable, the reference temperature values must be set.
- Temperature Source must be configured and set up.
- One matrix must be selected as the active matrix (the matrix used for measurement).

Optional tasks in setting up concentration measurement

The following tasks are optional:

- Modifying names and labels
- Configuring operational parameters
 - Extrapolation alerts
 - Calculation method (matrix or equation)
 - Matrix switching

4.6.2 Set up concentration measurement using ProLink III

This section guides you through the tasks required to set up, configure, and implement concentration measurement.

Restriction

This section does not cover building a concentration matrix. See *Micro Motion Enhanced Density Application: Theory, Configuration, and Use* for detailed information on building a matrix.

1. [Enable the concentration measurement application using ProLink III](#)
2. [Load a concentration matrix using ProLink III](#)
3. [Set reference temperature values for specific gravity using ProLink III](#)
4. [Set up temperature data for concentration measurement using ProLink III](#)
5. [Modify matrix names and labels using ProLink III](#)
6. [Modify operational parameters for concentration measurement using ProLink III](#)
7. [Select the active concentration matrix using ProLink III](#)

Enable the concentration measurement application using ProLink III

The concentration measurement application must be enabled before you can perform any setup. If the concentration measurement application was enabled at the factory, you do not need to enable it now.

1. Choose Device Tools > Configuration > Transmitter Options.
2. If the API referral application is enabled, disable it and click Apply.

The concentration measurement application and the API referral application cannot be enabled simultaneously.

3. Set Concentration Measurement to Enabled and click Apply.

Load a concentration matrix using ProLink III

At least one concentration matrix must be loaded onto your transmitter. You can load up to six.

Tip

In many cases, concentration matrices were ordered with the device and loaded at the factory. You may not need to load any matrices.

Prerequisites

[Standard matrices for the concentration measurement application](#)
[Concentration measurement matrices available by order](#)

The concentration measurement application must be enabled on your device.

For each concentration matrix that you want to load, you need a file containing the matrix data. The ProLink III installation includes a set of standard concentration matrices. Other matrices are available from Micro Motion.

Tips

- If you have a custom matrix on another device, you can save it to a file, then load it to the current device.
 - If you have a matrix file in ProLink II format, you can load it using ProLink III.
-

You must know the following information for your matrix:

- The derived variable that the matrix is designed to calculate
 - The density unit that the matrix was built with
 - The temperature unit that the matrix was built with
-

Important

- All concentration matrices on your transmitter must use the same derived variable.
 - If you change the setting of Derived Variable, all existing concentration matrices will be deleted from transmitter memory. Set Derived Variable before loading concentration matrices.
 - If you want the meter to calculate Net Mass Flow Rate, the derived variable must be set to Mass Concentration (Density). If your matrix is not set up for Mass Concentration (Density), contact Micro Motion for assistance or for a custom matrix.
 - If you want the meter to calculate Net Volume Flow Rate, the derived variable must be set to Volume Concentration (Density). If your matrix is not set up for Volume Concentration (Density), contact Micro Motion for assistance or for a custom matrix.
-

If you plan to use matrix switching, you must identify the two matrices to be used for switching and load them into Slot 1 and Slot 2.

Procedure

1. Choose Device Tools > Configuration > Process Measurement > Line Density and set Density Unit to the density unit used by your matrix.
-

Important

When you load a matrix, if the density unit is not correct, concentration data will be incorrect. The density units must match at the time of loading. You can change the density unit after the matrix is loaded.

2. Choose Device Tools > Configuration > Process Measurement > Line Temperature and set Temperature Unit to the temperature unit used by your matrix.
-

Important

When you load a matrix, if the temperature unit is not correct, concentration data will be incorrect. The temperature units must match at the time of loading. You can change the temperature unit after the matrix is loaded.

3. Choose Device Tools > Configuration > Process Measurement > Concentration Measurement.

The Concentration Measurement window is displayed. It is organized into steps that allow you to perform several different setup and configuration tasks. For this task, you will not use all the steps.

4. In Step 1, ensure that the setting of Derived Variable matches the derived variable used by your matrix. If it does not, change it as required and click Apply.

Important

If you change the setting of Derived Variable, all existing concentration matrices will be deleted from transmitter memory. Verify the setting of Derived Variable before continuing.

5. Load one or more matrices.
 - a. In Step 2, set Matrix Being Configured to the location (slot) to which the matrix will be loaded.
 - b. Click Load Matrix from a File, navigate to the matrix file on your computer, and load it.
 - c. Repeat until all required matrices are loaded.
6. (Optional) Set the density and temperature units to the units you want to use for measurement.

Related information

[Matrix switching](#)

[Derived variables and calculated process variables](#)

[Configure Temperature Measurement Unit](#)

[Configure Density Measurement Unit](#)

[Measuring Net Mass Flow Rate and Net Volume Flow Rate](#)

Set reference temperature values for specific gravity using ProLink III

When Derived Variable is set to Specific Gravity, you must set the reference temperature to be used for density measurement and the reference temperature of water, and then verify the density of water at the configured reference temperature. The two reference temperature values affect specific gravity measurement.

Additionally, the two reference temperature values affect any concentration process variable that is calculated by equation, rather than by matrix, because the equations are based on specific gravity.

Typically, the two reference temperature values are the same, but this is not required.

Restriction

If Derived Variable is not set to Specific Gravity, do not change any of these values. These are set by the active concentration matrix.

Procedure

1. Choose Device Tools > Configuration > Process Measurement > Concentration Measurement.

The Concentration Measurement window is displayed. It is organized into steps that allow you to perform several different setup and configuration tasks. For this task, you will not use all the steps.

2. Scroll to Step 2, set Matrix Being Configured to the matrix you want to modify, and click Change Matrix.
3. Scroll to Step 3, then perform the following actions:
 - a. Set Reference Temperature for Referred Density to the temperature to which line density will be corrected for use in the specific gravity calculation.
 - b. Set Reference Temperature for Water to the water temperature that will be used in the specific gravity calculation.
 - c. Set Water Density at Reference Temperature to the density of water at the specified reference temperature.

The transmitter automatically calculates the density of water at the specified temperature. The new value will be displayed the next time that transmitter memory is read. You can enter a different value if you want to.
4. Click the Apply button at the bottom of Step 3.

Related information

[Using equations to calculate specific gravity, °Baumé, °Brix, °Plato, and °Twaddell](#)

Set up temperature data for concentration measurement using ProLink III

The concentration measurement application uses line temperature data in its calculations. You must decide how to provide this data, then perform the required configuration and setup. Temperature data from the on-board temperature sensor (RTD) is always available. You can set up an external temperature device and use external temperature data if you want to.

The temperature setup that you establish here will be used for all concentration measurement matrices on this meter.

Important

Line temperature data is used in several different measurements and calculations. It is possible to use the internal RTD temperature in some areas and an external temperature in others. The transmitter stores the internal RTD temperature and the external temperature separately. However, the transmitter stores only one alternate temperature value, which may be either an external temperature or the configured fixed value. Accordingly, if you set up polling for temperature in one area, and digital communications in another, and configure a fixed temperature value in a third, the fixed value will be overwritten by polling and digital communications, and polling and digital communications will overwrite each other.

Prerequisites

If you plan to poll an external device, the primary mA output (Channel A) must be wired to support HART communications.

Procedure

1. Choose Device Tools > Configuration > Process Measurement > Concentration Measurement.

The Concentration Measurement window is displayed. It is organized into steps that allow you to perform several different setup and configuration tasks. For this task, you will not use all the steps.

2. Scroll to Step 4.
3. Choose the method to be used to supply temperature data, and perform the required setup.

Option	Description	Setup						
Internal RTD temperature data	Temperature data from the on-board temperature sensor (RTD) is used.	<ol style="list-style-type: none"> a. Set Line Temperature Source to Internal RTD. b. Click Apply. 						
Polling	The meter polls an external device for temperature data. This data will be available in addition to the internal RTD temperature data.	<ol style="list-style-type: none"> a. Set Line Temperature Source to Poll for External Value. b. Set Polling Slot to an available slot. c. Set Polling Control to Poll as Primary or Poll as Secondary. 						
		<table border="1"> <thead> <tr> <th>Option</th> <th>Description</th> </tr> </thead> <tbody> <tr> <td>Poll as Primary</td> <td>No other HART masters will be on the network. The Field Communicator is not a HART master.</td> </tr> <tr> <td>Poll as Secondary</td> <td>Other HART masters will be on the network. The Field Communicator is not a HART master.</td> </tr> </tbody> </table>	Option	Description	Poll as Primary	No other HART masters will be on the network. The Field Communicator is not a HART master.	Poll as Secondary	Other HART masters will be on the network. The Field Communicator is not a HART master.
		Option	Description					
Poll as Primary	No other HART masters will be on the network. The Field Communicator is not a HART master.							
Poll as Secondary	Other HART masters will be on the network. The Field Communicator is not a HART master.							
<ol style="list-style-type: none"> d. Set External Device Tag to the HART tag of the temperature device. e. Click Apply. 								
Digital communications	A host writes temperature data to the meter at appropriate intervals. This data will be available in addition to the internal RTD temperature data.	<ol style="list-style-type: none"> a. Set Line Temperature Source to Fixed Value or Digital Communications. b. Click Apply. c. Perform the necessary host programming and communications setup to write temperature data to the meter at appropriate intervals. 						

Postrequisites

If you are using external temperature data, verify the external temperature value displayed in the Inputs group on the ProLink III main window.

Need help? If the value is not correct:

- Ensure that the external device and the meter are using the same measurement unit.
- For polling:
 - Verify the wiring between the meter and the external device.
 - Verify the HART tag of the external device.
- For digital communications:

- Verify that the host has access to the required data.
- Verify that the host is writing to the correct register in memory, using the correct data type.
- If necessary, apply an offset.

Modify matrix names and labels using ProLink III

For convenience, you can change the name of a concentration matrix and the label used for its measurement unit. This does not affect measurement.

1. Choose Device Tools > Configuration > Process Measurement > Concentration Measurement.
The Concentration Measurement window is displayed. It is organized into steps that allow you to perform several different setup and configuration tasks. For this task, you will not use all the steps.
2. Scroll to Step 2, set Matrix Being Configured to the matrix you want to modify, and click Change Matrix.
3. Scroll to Step 3, then perform the following actions:
 - a. Set Concentration Units Label to the label that will be used for the concentration unit.
 - b. If you set Concentration Units Label to Special, enter the custom label in User-Defined Label.
 - c. In Matrix Name, enter the name to be used for the matrix.
4. Click the Apply button at the bottom of Step 3.

Modify operational parameters for concentration measurement using ProLink III

You can enable and disable extrapolation alerts, set extrapolation alert limits, and control matrix switching. These parameters control the behavior of the concentration measurement application but do not affect measurement directly. Additionally, for certain types of concentration measurement, you can select the calculation method to be used.

1. Choose Device Tools > Configuration > Process Measurement > Concentration Measurement.
The Concentration Measurement window is displayed. It is organized into steps that allow you to perform several different setup and configuration tasks. For this task, you will not use all the steps.
2. Scroll to Step 2, set Matrix Being Configured to the matrix you want to modify, and click Change Matrix.
3. Scroll to Step 4.
4. Set up extrapolation alerts.

Each concentration matrix is built for a specific density range and a specific temperature range. If line density or line temperature goes outside the range, the transmitter will extrapolate concentration values. However, extrapolation may

affect accuracy. Extrapolation alerts are used to notify the operator that extrapolation is occurring, and can also be used to initiate matrix switching. Each concentration matrix has its own extrapolation alert settings.

- a. Set Extrapolation Alert Limit to the point, in percent, at which an extrapolation alert will be posted.
- b. Enable or disable the high and low limit alerts for temperature and density, as desired, and click Apply.

Important

If you plan to use matrix switching, you must enable the appropriate extrapolation alerts.

Example: If Extrapolation Alert Limit is set to 5%, High Extrapolation Limit (Temperature) is enabled, and the matrix is built for a temperature range of 40 °F to 80 °F, an extrapolation alert will be posted if line temperature goes above 82 °F.

5. If applicable, use the Equation Selection parameter to specify the type of calculation to be used, and click Apply.

This option is available only when Derived Variable is set to Specific Gravity.

Option	Description
Specific Gravity	Referred density is calculated from the matrix. The result is used in the specific gravity equation. The output is specific gravity.
Baume	Specific gravity is calculated as described above, and the result is used in the °Baumé equation. The output is specific gravity and °Baumé (light or heavy).
Brix	Specific gravity is calculated as described above and the result is used in the °Brix equation. The output is specific gravity and °Brix.
Plato	Specific gravity is calculated as described above, and the result is used in the °Plato equation. The output is specific gravity and °Plato.
Twaddell	Specific gravity is calculated as described above, and the result is used in the °Twaddell equation. The output is specific gravity and °Twaddell.

6. Enable or disable Matrix Switching as desired, and click Apply.

When matrix switching is enabled and an extrapolation alert occurs, the transmitter automatically switches from the matrix in Slot 1 to the matrix in Slot 2, or vice versa. This occurs only if no extrapolation alert would be generated by the other matrix. Matrix switching is not applicable to any other slots.

Related information

[Using equations to calculate specific gravity, °Baumé, °Brix, °Plato, and °Twaddell](#)
[Matrix switching](#)

Select the active concentration matrix using ProLink III

You must select the concentration matrix to be used for measurement. Although the transmitter can store up to six concentration matrices, only one matrix can be used for measurement at any one time.

1. Choose Device Tools > Configuration > Process Measurement > Concentration Measurement.

The Concentration Measurement window is displayed. It is organized into steps that allow you to perform several different setup and configuration tasks. For this task, you will not use all the steps.

2. Scroll to Step 2, set Active Matrix to the matrix you want to use and click Change Matrix.

Note

To support matrix switching, you must select the matrix in Slot 1 or the matrix in Slot 2.

Related information

[Matrix switching](#)

4.6.3 Set up concentration measurement using the Field Communicator

This section guides you through most of the tasks related to setting up and implementing the concentration measurement application.

Restrictions

- This section does not cover building a concentration matrix. See *Micro Motion Enhanced Density Application: Theory, Configuration, and Use* for detailed information on building a matrix.
 - You cannot load a concentration matrix using the Field Communicator. If you need to load a matrix, you must use ProLink III.
-

1. [Enable the concentration measurement application using the Field Communicator](#)
2. [Set reference temperature values for specific gravity using the Field Communicator](#)
3. [Provide temperature data for concentration measurement using the Field Communicator](#)
4. [Modify matrix names and labels using the Field Communicator](#)
5. [Modify concentration measurement operational parameters using the Field Communicator](#)
6. [Select the active concentration matrix using the Field Communicator](#)

Enable the concentration measurement application using the Field Communicator

The concentration measurement application must be enabled before you can perform any setup. If the concentration measurement application was enabled at the factory, you do not need to enable it now.

1. Choose Overview > Device Information > Applications > Enable/Disable Applications.

2. If the API referral application is enabled, disable it.
The concentration measurement application and the API referral application cannot be enabled simultaneously.
3. Enable the concentration measurement application.

Set reference temperature values for specific gravity using the Field Communicator

When Derived Variable is set to Specific Gravity, you must set the reference temperature to be used for density measurement and the reference temperature of water, and then verify the density of water at the configured reference temperature. The two reference temperature values affect specific gravity measurement.

Additionally, the two reference temperature values affect any concentration process variable that is calculated by equation, rather than by matrix, because the equations are based on specific gravity.

Typically, the two reference temperature values are the same, but this is not required.

Restriction

If Derived Variable is not set to Specific Gravity, do not change any of these values. These are set by the active concentration matrix. To check the setting of Derived Variable, choose Configure > Manual Setup > Measurements > Conc Measure (CM) > CM Configuration.

Important

Do not change the setting of Derived Variable. If you change the setting of Derived Variable, all existing concentration matrices will be deleted from transmitter memory.

Procedure

1. Choose Configure > Manual Setup > Measurements > Conc Measure (CM) > Configure Matrix.
2. Set Matrix Being Configured to the matrix you want to modify.
3. Choose Reference Conditions, then perform the following actions:
 - a. Set Reference Temp to the temperature to which line density will be corrected for use in the specific gravity calculation.
 - b. Set Water Ref Temp to the water temperature that will be used in the specific gravity calculation.
 - c. Set Water Ref Density to the density of water at the specified reference temperature.

The transmitter automatically calculates the density of water at the specified temperature. The new value will be displayed the next time that transmitter memory is read. You can enter a different value if you want to.

Related information

[Using equations to calculate specific gravity, °Baumé, °Brix, °Plato, and °Twaddell](#)

Provide temperature data for concentration measurement using the Field Communicator

The concentration measurement application uses line temperature data in its calculations. You must decide how to provide this data, then perform the required configuration and setup. Temperature data from the on-board temperature sensor (RTD) is always available. You can set up an external temperature device and use external temperature data if you want to.

The temperature setup that you establish here will be used for all concentration measurement matrices on this meter.

Important

Line temperature data is used in several different measurements and calculations. It is possible to use the internal RTD temperature in some areas and an external temperature in others. The transmitter stores the internal RTD temperature and the external temperature separately. However, the transmitter stores only one alternate temperature value, which may be either an external temperature or the configured fixed value. Accordingly, if you set up polling for temperature in one area, and digital communications in another, and configure a fixed temperature value in a third, the fixed value will be overwritten by polling and digital communications, and polling and digital communications will overwrite each other.

Prerequisites

If you plan to poll an external device, the primary mA output (Channel A) must be wired to support HART communications.

Procedure

Choose the method to be used to supply temperature data, and perform the required setup.

Method	Description	Setup
Internal RTD temperature data	Temperature data from the on-board temperature sensor (RTD) is used.	<ol style="list-style-type: none"> a. Choose Configure > Manual Setup > Measurements > External Inputs > Temperature. b. Set External Temperature to Disable.

Method	Description	Setup						
Polling	The meter polls an external device for temperature data. This data will be available in addition to the internal RTD temperature data.	<ol style="list-style-type: none"> Choose Configure > Manual Setup > Measurements > External Inputs > Temperature. Set External Temperature to Enable. Choose Configure > Manual Setup > Inputs/Outputs > External Device Polling. Choose an unused polling slot. Set Poll Control to Poll as Primary or Poll as Secondary. 						
		<table border="1"> <thead> <tr> <th>Option</th> <th>Description</th> </tr> </thead> <tbody> <tr> <td>Poll as Primary</td> <td>No other HART masters will be on the network. The Field Communicator is not a HART master.</td> </tr> <tr> <td>Poll as Secondary</td> <td>Other HART masters will be on the network. The Field Communicator is not a HART master.</td> </tr> </tbody> </table>	Option	Description	Poll as Primary	No other HART masters will be on the network. The Field Communicator is not a HART master.	Poll as Secondary	Other HART masters will be on the network. The Field Communicator is not a HART master.
		Option	Description					
		Poll as Primary	No other HART masters will be on the network. The Field Communicator is not a HART master.					
Poll as Secondary	Other HART masters will be on the network. The Field Communicator is not a HART master.							
<ol style="list-style-type: none"> Set External Device Tag to the HART tag of the external temperature device. Set Polled Variable to Temperature. 								
Digital communications	A host writes temperature data to the meter at appropriate intervals. This data will be available in addition to the internal RTD temperature data.	<ol style="list-style-type: none"> Choose Configure > Manual Setup > Measurements > External Inputs > Temperature. Set External Temperature to Enable. Perform the necessary host programming and communications setup to write temperature data to the meter at appropriate intervals. 						

Postrequisites

Choose Service Tools > Variables > External Variables and verify the value for External Temperature.

Need help? If the value is not correct:

- Ensure that the external device and the meter are using the same measurement unit.
- For polling:
 - Verify the wiring between the meter and the external device.
 - Verify the HART tag of the external device.
- For digital communications:
 - Verify that the host has access to the required data.
 - Verify that the host is writing to the correct register in memory, using the correct data type.
- If necessary, apply an offset.

Modify matrix names and labels using the Field Communicator

For convenience, you can change the name of a concentration matrix and the label used for its measurement unit. This does not affect measurement.

1. Choose Configure > Manual Setup > Measurements > Conc Measure (CM) > Configure Matrix.
2. Set Matrix Being Configured to the matrix you want to modify.
3. Set Matrix Name to the name to be used for the matrix.
4. Set Concentration Units to the label that will be used for the concentration unit.
5. If you set Concentration Units to Special, choose Concentration Label and enter the custom label.

Modify concentration measurement operational parameters using the Field Communicator

You can enable and disable extrapolation alerts, set extrapolation alert limits, and control matrix switching. These parameters control the behavior of the concentration measurement application but do not affect measurement directly. Additionally, for certain types of concentration measurement, you can select the calculation type to be used.

1. Choose Configure > Manual Setup > Measurements > Conc Measure (CM) > Configure Matrix.
2. Set Matrix Being Configured to the matrix you want to modify.
3. If applicable, set Equation Type to the type of calculation to be used.

Option	Description
Specific Gravity	Referred density is calculated from the matrix. The result is used in the specific gravity equation. The output is specific gravity.
Baume	Specific gravity is calculated as described above, and the result is used in the °Baumé equation. The output is specific gravity and °Baumé (light or heavy).
Brix	Specific gravity is calculated as described above and the result is used in the °Brix equation. The output is specific gravity and °Brix.
Plato	Specific gravity is calculated as described above, and the result is used in the °Plato equation. The output is specific gravity and °Plato.
Twaddell	Specific gravity is calculated as described above, and the result is used in the °Twaddell equation. The output is specific gravity and °Twaddell.

This option is available only when Derived Variable is set to Specific Gravity.

4. Set up extrapolation alerts.

Each concentration matrix is built for a specific density range and a specific temperature range. If line density or line temperature goes outside the range, the transmitter will extrapolate concentration values. However, extrapolation may affect accuracy. Extrapolation alerts are used to notify the operator that extrapolation is occurring, and can also be used to initiate matrix switching. Each concentration matrix has its own extrapolation alert settings.

- a. Set Extrapolation Alert Limit to the point, in percent, at which an extrapolation alert will be posted.
- b. Choose Online > Configure > Alert Setup > Concentration Measurement Alerts.
- c. Enable or disable the high and low alerts for temperature and density, as desired.

Important

If you are using matrix switching, you must enable the appropriate extrapolation alerts.

Example: If Extrapolation Alert Limit is set to 5%, High Extrapolation Limit (Temperature) is enabled, and the matrix is built for a temperature range of 40 °F to 80 °F, an extrapolation alert will be posted if line temperature goes above 82 °F.

5. Choose Configure > Manual Setup > Measurements > Conc Measure (CM) > CM Configuration, then enable or disable Matrix Switching as desired.

When matrix switching is enabled and an extrapolation alert occurs, the transmitter automatically switches from the matrix in Slot 1 to the matrix in Slot 2, or vice versa. This occurs only if no extrapolation alert would be generated by the other matrix. Matrix switching is not applicable to any other slots.

Related information

[Using equations to calculate specific gravity, °Baumé, °Brix, °Plato, and °Twaddell Matrix switching](#)

Select the active concentration matrix using the Field Communicator

You must select the concentration matrix to be used for measurement. Although the transmitter can store up to six concentration matrices, only one matrix can be used for measurement at any one time.

Set Active Matrix to the matrix you want to use.

Related information

[Matrix switching](#)

4.6.4 Using equations to calculate specific gravity, °Baumé, °Brix, °Plato, and °Twaddell

Whenever the derived variable is set to Specific Gravity, you have the option of using equations to calculate °Baumé, °Brix, °Plato, and °Twaddell, instead of matrix referral. Whenever the equation method is used, the active matrix is used to measure referred density. This value is used to calculate specific gravity. The result of the specific gravity calculation is then used in the equations used to calculate °Baumé, °Brix, °Plato, or °Twaddell.

Specific gravity is always calculated using the two reference temperatures that are specified during concentration measurement configuration.

If you are measuring in °Baumé, the meter will automatically select the appropriate equation according to the specific gravity of the process fluid, and will switch equations when specific gravity crosses 1.0.

Table 4-6: Equations used for specific gravity, °Baumé, °Brix, °Plato, and °Twaddell

Equation	Current value of specific gravity	Equation
Specific Gravity	N/A	$SG = \frac{\rho_{RefTemp}}{\rho_{WaterRefTemp}}$
°Baumé	1.0 or greater (°Baumé heavy)	$^{\circ}Baum\acute{e} = 145 - \frac{145}{SG}$
	Less than 1.0 (°Baumé light)	$^{\circ}Baum\acute{e} = \frac{140}{SG} - 130$
°Brix	N/A	$^{\circ}Brix = 318.906 - \left(\frac{384.341}{SG}\right) + \left(\frac{66.1086}{SG^2}\right)$
°Plato	N/A	$^{\circ}Plato = (668.72 \times SG) - 463.37 - (205.347 \times SG^2)$
°Twaddell	N/A	$^{\circ}Twaddell = 200 \times (SG - 1)$

- SG Specific gravity of process fluid
- $\rho_{RefTemp}$ Density of process fluid at Reference Temperature for Referred Density, as measured using the active concentration matrix
- $\rho_{WaterRefTemp}$ Density of water at Reference Temperature for Water

Related information

- [Set reference temperature values for specific gravity using ProLink III](#)
- [Set reference temperature values for specific gravity using the Field Communicator](#)

4.6.5 Matrix switching

Matrix switching can be used to measure different process fluids without resetting the active matrix manually. Matrix switching can also be used to increase measurement accuracy.

When matrix switching is enabled, the meter automatically switches between the matrices in Slot 1 and Slot 2 whenever an extrapolation alert is present for the active matrix but would not be generated by the other matrix. For example:

- The matrix in Slot 2 is active, the high-density extrapolation alert is enabled, and matrix switching is enabled. Line density goes above the range of the matrix plus the extrapolation limit. The meter posts an alert, then checks the range of the matrix in Slot 1. No extrapolation alert would be posted, so the meter automatically switches to the matrix in Slot 1.

- The matrix in Slot 2 is active, the high-density extrapolation alert is enabled, and matrix switching is enabled. Line density goes above the range of the matrix plus the extrapolation limit. The meter posts an alert, then checks the range of the matrix in Slot 1. The current line density would also generate an extrapolation alert for this matrix, so the meter does not switch.

You can control the conditions that trigger matrix switching by enabling or disabling specific extrapolation alerts. For example, if the low-density and high-density extrapolation alerts are enabled, but the low-temperature and high-temperature extrapolation alerts are disabled, matrix switching will be triggered only by changes in line density. Changes in line temperature will not trigger matrix switching.

Depending on your application, you may need to set up your matrices and extrapolation limits so that there is no overlap in density and/or temperature, or so that there is slight overlap.

On the display, the matrix number for the active matrix will alternately flash with the concentration and referred density units.

Example: Using matrix switching to measure different process fluids

The line may contain either of two process fluids, depending on the current product. The matrix in Slot 1 is appropriate for the first process fluid. The matrix in Slot 2 is appropriate for the second process fluid. Whenever the line is switched, an extrapolation alert is posted for the current matrix, and the meter automatically switches to use the other matrix.

To ensure that the correct matrix is used, there can be no overlap between the ranges of the two matrices. In other words:

- If you are using density to trigger matrix switching, there can be no density values that are within the ranges of both matrices, after the extrapolation limits are applied.
- If you are using temperature to trigger matrix switching, there can be no temperature values that are within the ranges of both matrices, after the extrapolation limits are applied.
- If you are using both density and temperature to trigger matrix switching, there can be no density or temperature values that are within the ranges of both matrices, after the extrapolation limits are applied.

Example: Using matrix switching to increase measurement accuracy

For some process fluids, measurement accuracy is increased when the matrix has a narrower temperature or density range. By using two matrices with adjacent or slightly overlapping ranges, increased accuracy is available over a wider range of process variation.

To ensure continuous process measurement, there should be no gap between the ranges, after the extrapolation limits are applied.

4.6.6 Measuring Net Mass Flow Rate and Net Volume Flow Rate

Net Mass Flow Rate is calculated by multiplying concentration by the mass flow rate. Net Volume Flow Rate is calculated by multiplying concentration by the volume flow rate.

To measure Net Mass Flow Rate, the following are required:

- A mass flow rate process variable, either measured or calculated, depending on what is available on your meter
- Concentration measurement configured and active, with Mass Concentration (Density) set as the derived variable

To measure Net Volume Flow Rate, the following are required:

- A volume flow rate process variable, either measured or calculated, depending on what is available on your meter
- Concentration measurement configured and active, with Volume Concentration (Density) set as the derived variable

4.7 Set up flow rate measurement

The meter does not measure flow rate directly. However, you can provide volume flow rate data to the meter and use this data to calculate mass flow rate.

4.7.1 Set up flow rate measurement using ProLink III

Prerequisites

- To calculate mass flow rate, you must be able to supply volume flow rate data to the meter.
- If you plan to poll an external device, the primary mA output must be wired to support HART communications.

Procedure

1. Choose Device Tools > Configuration > I/O > Inputs > External Inputs.
2. Set Mass Flow (Calculated) to Enabled and click Apply.
3. Set Mass Flow Rate (Calculated) Unit to the unit in which the mass flow rate will be reported.
4. Set Line Volume Flow Rate Unit to the units used by the external volume measurement device
5. Set Line Volume Flow Source to the method to be used to retrieve volume flow data and perform the required setup.

Option	Description	Setup
Polling	The meter polls an external device for volume flow data and calculates the equivalent mass flow rate.	<ol style="list-style-type: none"> Set Line Volume Flow Source to Poll for External Value. Set Polling Slot to an available slot. Set Polling Control to Poll as Primary or Poll as Secondary. Set External Device Tag to the HART tag of the volume flow measurement device.
Digital communications	A host writes volume flow data to the meter at appropriate intervals, and the meter calculates the equivalent mass flow rate.	<ol style="list-style-type: none"> Set Line Volume Flow Source to Fixed Value or Digital Communications. Perform the necessary host programming and communications setup to write volume flow data to the meter at appropriate intervals.

Tip

A fixed value is not recommended. A fixed value may produce inaccurate process data.

The following process variables are now available:

- Line Volume Flow Rate
- Mass Flow Rate (Calculated)

If the concentration measurement application is enabled and configuration requirements are met, one of the following process variables is also available:

- Net Volume Flow Rate
- Net Mass Flow Rate

Postrequisites

To verify the volume flow rate, view the value displayed on the ProLink III main window, in the Inputs group.

To verify the calculated mass flow rate, set up one of the ProLink III gauges to display it.

Need help? If the value is not correct:

- Ensure that the external device and the meter are using the same measurement unit.
- For polling:
 - Verify the wiring between the meter and the external device.
 - Verify the HART tag of the external device.
- For digital communications:
 - Verify that the host has access to the required data.
 - Verify that the host is writing to the correct register in memory, using the correct data type.
- If necessary, apply an offset.

Related information

[Measuring Net Mass Flow Rate and Net Volume Flow Rate](#)

4.7.2 Set up flow rate measurement using the Field Communicator

Prerequisites

- To calculate mass flow rate, you must be able to supply volume flow rate data to the meter.
- If you plan to poll an external device, the primary mA output must be wired to support HART communications.

Procedure

1. Choose Configure > Manual Setup > Measurements > Mass (Calculated) and set Mass Flow Rate Unit to the unit in which the mass flow rate will be reported.
2. Choose Configure > Manual Setup > Measurements > Volume and set Volume Flow Rate Unit to the unit used by the external volume measurement device.
3. Choose Configure > Manual Setup > Measurements > External Inputs > Volume and set Volume Flow Source to Enabled.
4. Choose the method to be used to supply volume flow rate data, and perform the required setup.

Method	Description	Setup				
Polling	The meter polls an external device for volume flow rate data.	a. Choose Configure > Manual Setup > Inputs/Outputs > External Device Polling.				
		b. Choose an unused polling slot.				
		c. Set Poll Control to Poll as Primary or Poll as Secondary.				
		<table border="1"> <thead> <tr> <th>Option</th> <th>Description</th> </tr> </thead> <tbody> <tr> <td>Poll as Primary</td> <td>No other HART masters will be on the network. The Field Communicator is not a HART master.</td> </tr> <tr> <td>Poll as Secondary</td> <td>Other HART masters will be on the network. The Field Communicator is not a HART master.</td> </tr> </tbody> </table>	Option	Description	Poll as Primary	No other HART masters will be on the network. The Field Communicator is not a HART master.
Option	Description					
Poll as Primary	No other HART masters will be on the network. The Field Communicator is not a HART master.					
Poll as Secondary	Other HART masters will be on the network. The Field Communicator is not a HART master.					
d. Set External Device Tag to the HART tag of the external pressure device.						
e. Set Polled Variable to Volume from Mag/Vortex Meter.						
Digital communications	A host writes volume flow rate data to the meter at appropriate intervals.	a. Perform the necessary host programming and communications setup to write volume flow rate data to the transmitter at appropriate intervals.				

Tip

A fixed value is not recommended. A fixed value may produce inaccurate process data.

The following process variables are now available:

- Line Volume Flow Rate
- Mass Flow Rate (Calculated)

If the concentration measurement application is enabled and configuration requirements are met, one of the following process variables is also available:

- Net Volume Flow Rate
- Net Mass Flow Rate

Postrequisites

Choose Service Tools > Variables > External Variables and verify the values for External Volume Flow Rate and Mass Flow Rate (Calculated).

Need help? If the value is not correct:

- Ensure that the external device and the meter are using the same measurement unit.
- For polling:
 - Verify the wiring between the meter and the external device.
 - Verify the HART tag of the external device.
- For digital communications:
 - Verify that the host has access to the required data.
 - Verify that the host is writing to the correct register in memory, using the correct data type.
- If necessary, apply an offset.

Related information

[*Measuring Net Mass Flow Rate and Net Volume Flow Rate*](#)

5 Configure device options and preferences

Topics covered in this chapter:

- [Configure the transmitter display](#)
- [Enable or disable the Acknowledge All Alerts display command](#)
- [Configure security for the display menus](#)
- [Configure alert handling](#)
- [Configure informational parameters](#)

5.1 Configure the transmitter display

You can control the process variables shown on the display and a variety of display behaviors.

- [Configure the language used for the display](#) (Section 5.1.1)
- [Configure the process variables and diagnostic variables shown on the display](#) (Section 5.1.2)
- [Configure the number of decimal places \(precision\) shown on the display](#) (Section 5.1.3)
- [Configure the refresh rate of data shown on the display](#) (Section 5.1.4)
- [Enable or disable automatic scrolling through the display variables](#) (Section 5.1.5)

5.1.1 Configure the language used for the display

Display	OFF-LINE MAINT > OFF-LINE CONFIG > DISPLAY > LANG
ProLink III	Device Tools > Configuration > Transmitter Display > General
Field Communicator	Configure > Manual Setup > Display > Language

Overview

Display Language controls the language used for process data and menus on the display.

Procedure

Select the language you want to use.

The languages available depend on your transmitter model and version.

5.1.2 Configure the process variables and diagnostic variables shown on the display

Display	<i>Not available</i>
ProLink III	Device Tools > Configuration > Transmitter Display > Display Variables
Field Communicator	Configure > Manual Setup > Display > Display Variables

Overview

You can control the process variables and diagnostic variables shown on the display, and the order in which they appear. The display can scroll through up to 15 variables in any order you choose. In addition, you can repeat variables or leave slots unassigned.

Restriction

You cannot set Display Variable 1 to None or to a diagnostic variable. Display Variable 1 must be set to a process variable.

Procedure

For each display variable you want to change, assign the process variable you want to use.

5.1.3 Configure the number of decimal places (precision) shown on the display

Display	<i>Not available</i>
ProLink III	Device Tools > Configuration > Transmitter Display > Display Variables
Field Communicator	Configure > Manual Setup > Display > Decimal Places

Overview

You can specify the number of decimal places (precision) that are shown on the display for each process variable or diagnostic variable. You can set the precision independently for each variable.

The display precision does not affect the actual value of the variable or the value used in calculations.

Procedure

1. Select a variable.
2. Set Number of Decimal Places to the number of decimal places you want shown when the process variable or diagnostic variable appears on the display.

For temperature and density process variables, the default value is 2 decimal places. For all other variables, the default value is 4 decimal places. The range is 0 to 5.

Tip

The lower the precision, the greater the change must be for it to be reflected on the display. Do not set the precision too low or too high to be useful.

5.1.4 Configure the refresh rate of data shown on the display

Display	OFF-LINE MAINT > OFF-LINE CONFIG > DISPLAY > RATE
ProLink III	Device Tools > Configuration > Transmitter Display > Display Variables
Field Communicator	Configure > Manual Setup > Display > Display Behavior > Refresh Rate

Overview

You can set Refresh Rate to control how frequently data is refreshed on the display.

Procedure

Set Refresh Rate to the desired value.

The default value is 1000 milliseconds. The range is 100 milliseconds to 10,000 milliseconds (10 seconds).

5.1.5 Enable or disable automatic scrolling through the display variables

Display	OFF-LINE MAINT > OFF-LINE CONFIG > DISPLAY > AUTO SCROLL
ProLink III	Device Tools > Configuration > Transmitter Display > General
Field Communicator	Configure > Manual Setup > Display > Display Behavior > Auto Scroll

Overview

You can configure the display to automatically scroll through the configured display variables or to show a single display variable until the operator activates Scroll. When you set automatic scrolling, you can also configure the length of time each display variable is displayed.

Procedure

1. Enable or disable Auto Scroll as desired.

Option	Description
Enabled	The display automatically scrolls through each display variable as specified by Scroll Rate. The operator can move to the next display variable at any time using Scroll.

Option	Description
Disabled (de-fault)	The display shows Display Variable 1 and does not scroll automatically. The operator can move to the next display variable at any time using Scroll.

2. If you enabled Auto Scroll, set Scroll Rate as desired.

The default value is 10 seconds.

Tip

Scroll Rate may not be available until you apply Auto Scroll.

5.2 Enable or disable the Acknowledge All Alerts display command

Display	OFF-LINE MAINT > OFF-LINE CONFIG > DISPLAY > ACK
ProLink III	Device Tools > Configuration > Transmitter Display > Ack All
Field Communicator	Configure > Manual Setup > Display > Display Menus > Acknowledge All

Overview

You can configure whether or not the operator can use a single command to acknowledge all alerts from the display.

Procedure

1. Ensure that the alert menu is accessible from the display.

To acknowledge alerts from the display, operators must have access to the alert menu.

2. Enable or disable Acknowledge All Alerts as desired.

Option	Description
Enabled (default)	Operators can use a single display command to acknowledge all alerts at once.
Disabled	Operators cannot acknowledge all alerts at once. Each alert must be acknowledged separately.

5.3 Configure security for the display menus

Display	OFF-LINE MAINT > OFF-LINE CONFIG > DISPLAY
ProLink III	Device Tools > Configuration > Transmitter Display > Display Security
Field Communicator	Configure > Manual Setup > Display > Display Menus

Overview

You can control operator access to different sections of the display off-line menu. You can also configure a passcode to control access.

Procedure

1. To control operator access to the maintenance section of the off-line menu, enable or disable Off-Line Menu.

Option	Description
Enabled (default)	Operator can access the maintenance section of the off-line menu. This access is required for configuration and calibration, including Known Density Verification.
Disabled	Operator cannot access the maintenance section of the off-line menu.

2. To control operator access to the alert menu, enable or disable Alert Menu.

Option	Description
Enabled (default)	Operator can access the alert menu. This access is required to view and acknowledge alerts, but is not required for Known Density Verification, configuration, or calibration.
Disabled	Operator cannot access the alert menu.

Note

The transmitter status LED changes color to indicate that there are active alerts, but does not show specific alerts.

3. To require a passcode for access to the off-line menu, enable or disable Off-Line Password.

Option	Description
Enabled	Operator is prompted for the off-line passcode at entry to the off-line menu.
Disabled (default)	No passcode is required for entry to the off-line menu.

4. Set Off-Line Password to the desired value.

The default value is 1234. The range is 0000 to 9999.

Tip

Record your passcode for future reference.

5.4 Configure alert handling

The alert handling parameters control the transmitter's response to process and device conditions.

- [Configure Fault Timeout](#) (Section 5.4.1)
- [Configure Alert Severity](#) (Section 5.4.2)

5.4.1 Configure Fault Timeout

Display	<i>Not available</i>
ProLink III	Device Tools > Configuration > Fault Processing
Field Communicator	Configure > Alert Setup > Alert Severity > Fault Timeout

Overview

Fault Timeout controls the delay before fault actions are performed.

Restriction

Fault Timeout is applied only to the following alerts (listed by Status Alert Code): A003, A004, A008, A016, A033. For all other alerts, fault actions are performed as soon as the alert is detected.

Procedure

Set Fault Timeout as desired.

The default value is 0 seconds. The range is 0 to 60 seconds.

If you set Fault Timeout to 0, fault actions are performed as soon as the alert condition is detected.

The fault timeout period begins when the transmitter detects an alert condition. During the fault timeout period, the transmitter continues to report its last valid measurements.

If the fault timeout period expires while the alert is still active, the fault actions are performed. If the alert condition clears before the fault timeout expires, no fault actions are performed.

5.4.2 Configure Alert Severity

Display	<i>Not available</i>
ProLink III	Device Tools > Configuration > Alert Severity
Field Communicator	Configure > Alert Setup > Alert Severity > Change Alert Severity

Overview

Use Alert Severity to control the fault actions that the transmitter performs when it detects an alert condition.

Restrictions

- For some alerts, Alert Severity is not configurable.
- For some alerts, Alert Severity can be set only to two of the three options.

Tip

Micro Motion recommends using the default settings for Alert Severity unless you have a specific requirement to change them.

Procedure

1. Select a status alert.
2. For the selected status alert, set Alert Severity as desired.

Option	Description
Fault	<p>Actions when fault is detected:</p> <ul style="list-style-type: none"> • The alert is posted to the Alert List. • Outputs go to the configured fault action (after Fault Timeout has expired, if applicable). • Digital communications go to the configured fault action (after Fault Timeout has expired, if applicable). • The status LED (if available) changes to red or yellow (depending on alert severity). <p>Actions when alert clears:</p> <ul style="list-style-type: none"> • Outputs return to normal behavior. • Digital communications return to normal behavior. • The status LED returns to green.
Informational	<p>Actions when fault is detected:</p> <ul style="list-style-type: none"> • The alert is posted to the Alert List. • The status LED (if available) changes to red or yellow (depending on alert severity). <p>Actions when alert clears:</p> <ul style="list-style-type: none"> • The status LED returns to green.
Ignore	No action

Status alerts and options for Status Alert Severity

Table 5-1: Status alerts and Status Alert Severity

Alert number	Alert title	Default severity	User can reset severity
A001	EEPROM Error	Fault	No
A002	RAM Error	Fault	No
A003	No Sensor Response	Fault	Yes
A004	Temperature Overrange	Fault	No
A006	Characterization Required	Fault	Yes
A008	Density Overrange	Fault	Yes
A009	Transmitter Initializing/Warming Up or Significant Process Instability	Ignore	Yes
A010	Calibration Failure	Fault	No
A014	Transmitter Failure	Fault	No
A016	Sensor Temperature (RTD) Failure	Fault	Yes
A020	Calibration Factors Missing	Fault	Yes
A021	Transmitter/Sensor/Software Mismatch	Fault	No
A029	Internal Electronics Failure	Fault	No
A030	Incorrect Board Type	Fault	No
A033	Insufficient Pickoff Signal	Fault	Yes
A037	Sensor Check Failed	Fault	Yes
A038	Time Period Signal Out of Range	Fault	No
A100	mA Output 1 Saturated	Informational	To Informational or Ignore only
A101	mA Output 1 Fixed	Informational	To Informational or Ignore only
A102	Drive Overrange	Informational	Yes
A104	Calibration in Progress	Informational	To Informational or Ignore only
A105	Two-Phase Flow	Informational	Yes
A106	Burst Mode Enabled	Informational	To Informational or Ignore only
A107	Power Reset Occurred	Informational	Yes
A113	mA Output 2 Saturated	Informational	To Informational or Ignore only
A114	mA Output 2 Fixed	Informational	To Informational or Ignore only

Table 5-1: Status alerts and Status Alert Severity (continued)

Alert number	Alert title	Default severity	User can reset severity
A115	No External Input or Polled Data	Informational	To Informational or Ignore only
A116	Temperature Overrange (API Referral)	Informational	Yes
A117	Density Overrange (API Referral)	Informational	Yes
A118	Discrete Output 1 Fixed	Informational	To Informational or Ignore only
A120	Curve Fit Failure (Concentration)	Informational	No
A121	Extrapolation Alert (Concentration)	Informational	Yes
A122	Pressure Overrange (API Referral)	Informational	Yes
A132	Sensor Simulation Active	Informational	Yes
A133	EEPROM Error (Display)	Informational	Yes
A136	Incorrect Display Type	Informational	Yes

5.5 Configure informational parameters

Display	<i>Not available</i>
ProLink III	Device Tools > Configuration > Meter Information
Field Communicator	Configure > Manual Setup > Info Parameters

Overview

The informational parameters can be used to identify or describe your meter. They are not used in process measurement and they are not required.

Procedure

Enter data as desired.

Parameter	Description
Meter Serial Number	The serial number of the device. Enter the value from the device tag.
Message	A message to be stored in device memory. The message can contain up to 32 characters.
Descriptor	A description of this device. The description can contain up to 16 characters.
Date	A static date (not updated by the meter). Enter the date in the form mm/dd/yyyy.
Flange Type	The sensor flange type for this device. Obtain the value from the documents shipped with the device or from a code in the model number.

Tips

- The Field Communicator does not support all informational parameters. If you need to configure all of the informational parameters, use ProLink III.
 - The Field Communicator allows you to configure HART Tag and HART Long Tag from this location. These parameters are replicated from Configure > Manual Setup > HART > Communications. These parameters are used in HART communications.
-

6 Integrate the meter with the control system

Topics covered in this chapter:

- [Configure Channel B](#)
- [Configure the mA output](#)
- [Configure the discrete output](#)
- [Configure an enhanced event](#)
- [Configure HART/Bell 202 communications](#)
- [Configure Modbus communications](#)
- [Configure Digital Communications Fault Action](#)

6.1 Configure Channel B

Display	OFF-LINE MAINT > OFF-LINE CONFIG > IO > CONFIG CH B
ProLink III	Device Tools > Configuration > I/O > Channels
Field Communicator	Configure > Manual Setup > Inputs/Outputs > Channels > Channel B

Overview

Depending on your device, you can configure Channel B to operate as either an mA output or a discrete output.

Restriction

You cannot configure Channel B on the FDM TPS device. On this device, Channel B always operates as a TPS output.

Prerequisites

The configuration of Channel B must match the wiring. See the installation manual for your device.

To avoid causing process errors:

- Configure Channel B before configuring the mA output or discrete output.
- Before changing the channel configuration, ensure that all control loops affected by the channel are under manual control.

Procedure

Set Channel B as desired.

Option	Description
mA output	Channel B will operate as the secondary mA output.
Discrete output	Channel B will operate as a discrete output.

6.2 Configure the mA output

The mA output is used to report the configured process variable. The mA output parameters control how the process variable is reported.

The FDM mA device has two mA outputs: Channel A and Channel B. Both outputs are fully configurable.

The FDM DO device has one mA output: Channel A. The output is fully configurable.

The FDM TPS device has one mA output: Channel A. The output is fully configurable.

Important

Whenever you change an mA output parameter, verify all other mA output parameters before returning the meter to service. In some situations, the transmitter automatically loads a set of stored values, and these values may not be appropriate for your application.

- [Configure mA Output Process Variable](#) (Section 6.2.1)
- [Configure Lower Range Value \(LRV\) and Upper Range Value \(URV\)](#) (Section 6.2.2)
- [Configure Added Damping](#) (Section 6.2.3)
- [Configure mA Output Fault Action and mA Output Fault Level](#) (Section 6.2.4)

6.2.1 Configure mA Output Process Variable

Display	OFF-LINE MAINT > OFF-LINE CONFIG > IO > CONFIG MAO 1 > AO 1 SRC
	OFF-LINE MAINT > OFF-LINE CONFIG > IO > CH B > MAO 2 > CONFIG MAO 2 > AO 2 SRC
ProLink III	Device Tools > Configuration > I/O > Outputs > mA Output > mA Output 1 > Source
	Device Tools > Configuration > I/O > Outputs > mA Output > mA Output 2 > Source
Field Communicator	Configure > Manual Setup > Inputs/Outputs > mA Output 1 > Primary Variable
	Configure > Manual Setup > Inputs/Outputs > mA Output 2 > Secondary Variable

Overview

Use mA Output Process Variable to select the variable that is reported over the mA output.

Prerequisites

If you are using the HART variables, be aware that changing the configuration of mA Output Process Variable will change the configuration of the HART Primary Variable (PV) and/or the HART Secondary Variable (SV).

Procedure

Set mA Output Process Variable as desired.

Default settings are shown in the following table.

Table 6-1: Default settings for mA Output Process Variable

Device	Channel	mA output	Default process variable assignment
FDM mA	Channel A	Primary mA output	Density
	Channel B	Secondary mA output	Temperature
FDM DO	Channel A	Primary mA output	Density
FDM TPS	Channel A	Primary mA output	Temperature

Postrequisites

If you changed the setting of mA Output Process Variable, verify the settings of Lower Range Value (LRV) and Upper Range Value (URV).

Options for mA Output Process Variable

The transmitter provides a basic set of options for mA Output Process Variable, plus several application-specific options. Different communications tools may use different labels for the options.

Table 6-2: Options for mA Output Process Variable

Process variable	Label		
	Display	ProLink III	Field Communicator
Standard			
Line Density	DENS	Line Density	Density
Line Temperature	TEMP	Line Temperature	Temperature
Line Temperature (External)	EXT T	Line Temperature (External or Fixed)	External Temperature
Line Pressure (External)	EXT P	Line Pressure (External or Fixed)	External Pressure
Drive Gain	DGAIN	Drive Gain	Drive Gain
Sensor Time Period	TP B	Sensor Time Period	Sensor Time Period
User-Defined Calculation Output	UCALC	User-Defined Calculation Output	User-Defined Calculation Output
Volume Flow Rate (External)	MAG V	Volume Flow Rate (External)	Volume from Mag/Vortex Meter
Mass Flow Rate (Calculated)	MAG M	Mass Flow Rate (Calculated)	Calculated Mass Flow from Mag Meter Input

Table 6-2: Options for mA Output Process Variable (continued)

Process variable	Label		
	Display	ProLink III	Field Communicator
API referral			
Referred Density (API)	RDENS	Referred Density (API)	Density at Reference (API)
Concentration measurement			
Specific Gravity	SG	Specific Gravity	Specific Gravity (CM)
Concentration	CONC	Concentration	Concentration (CM)
Referred Density (Concentration)	RDENS	Referred Density (Concentration)	Density at Reference (CM)
Net Mass Flow Rate	NET M	Net Mass Flow Rate	Net Mass Flow Rate (CM)
Net Volume Flow Rate	NET V	Net Volume Flow Rate	Net Volume Flow Rate (CM)

6.2.2 Configure Lower Range Value (LRV) and Upper Range Value (URV)

Display	OFF-LINE MAINT > OFF-LINE CONFIG > IO > CONFIG MAO 1 > 4 mA OFF-LINE MAINT > OFF-LINE CONFIG > IO > CONFIG MAO 1 > 20 mA
	OFF-LINE MAINT > OFF-LINE CONFIG > IO > CH B > MAO 2 > CONFIG MAO 2 > 4 mA OFF-LINE MAINT > OFF-LINE CONFIG > IO > CH B > MAO 2 > CONFIG MAO 2 > 20 mA
ProLink III	Device Tools > Configuration > I/O > Outputs > mA Output > mA Output 1 > Lower Range Value Device Tools > Configuration > I/O > Outputs > mA Output > mA Output 1 > Upper Range Value
	Device Tools > Configuration > I/O > Outputs > mA Output > mA Output 2 > Lower Range Value Device Tools > Configuration > I/O > Outputs > mA Output > mA Output 2 > Upper Range Value
Field Communicator	Configure > Manual Setup > Inputs/Outputs > mA Output 1 > mA Output Settings > PV LRV Configure > Manual Setup > Inputs/Outputs > mA Output 1 > mA Output Settings > PV URV
	Configure > Manual Setup > Inputs/Outputs > mA Output 2 > mA Output Settings > SV LRV Configure > Manual Setup > Inputs/Outputs > mA Output 2 > mA Output Settings > SV URV

Overview

The Lower Range Value (LRV) and Upper Range Value (URV) are used to scale the mA output, that is, to define the relationship between mA Output Process Variable and the mA output level.

Prerequisites

Ensure that mA Output Process Variable is set to the desired process variable. Each process variable has its own set of LRV and URV values. When you change the values of LRV and URV, you are configuring values for the currently assigned mA output process variable.

Ensure that the measurement unit for the configured process variable has been set as desired.

Procedure

Set LRV and URV as desired.

- LRV is the value of mA Output Process Variable represented by an output of 4 mA. The default value for LRV depends on the setting of mA Output Process Variable. Enter LRV in the measurement units that are configured for mA Output Process Variable.
- URV is the value of mA Output Process Variable represented by an output of 20 mA. The default value for URV depends on the setting of mA Output Process Variable. Enter URV in the measurement units that are configured for mA Output Process Variable.

Tip

For best performance:

- Set $LRV \geq LSL$ (lower sensor limit).
- Set $URV \leq USL$ (upper sensor limit).
- Set these values so that the difference between URV and LRV is \geq Min Span (minimum span).

Defining URV and LRV within the recommended values for Min Span, LSL, and USL ensures that the resolution of the mA output signal is within the range of the bit precision of the D/A converter.

Note

You can set URV below LRV. For example, you can set URV to 50 and LRV to 100.

The mA output uses a range of 4–20 mA to represent mA Output Process Variable. Between LRV and URV, the mA output is linear with the process variable. If the process variable drops below LRV or rises above URV, the transmitter posts an output saturation alert.

6.2.3 Configure Added Damping

Display	<i>Not available</i>
ProLink III	Device Tools > Configuration > I/O > Outputs > mA Output > mA Output 1 > Added Damping
	Device Tools > Configuration > I/O > Outputs > mA Output > mA Output 2 > Added Damping
Field Communicator	Configure > Manual Setup > Inputs/Outputs > mA Output 1 > mA Output Settings > PV Added Damping
	Configure > Manual Setup > Inputs/Outputs > mA Output 2 > mA Output Settings > SV Added Damping

Overview

Added Damping controls the amount of damping that will be applied to the mA output.

Damping is used to smooth out small, rapid fluctuations in process measurement. Damping Value specifies the time period (in seconds) over which the transmitter will spread changes in the process variable. At the end of the interval, the internal value will reflect 63% of the change in the actual measured value.

Added Damping affects the reporting of mA Output Process Variable through the mA output only. It does not affect the reporting of that process variable via any other method (e.g., a frequency output or digital communications), or the value of the process variable used in calculations.

Note

Added Damping is not applied if the mA output is fixed (for example, during loop testing) or if the mA output is reporting a fault. Added Damping is applied while sensor simulation is active.

Procedure

Set Added Damping to the desired value.

The default value is 0.0 seconds. The range is 0.0 to 440 seconds.

When you specify a value for Added Damping, the transmitter automatically rounds the value down to the nearest valid value.

Interaction between mA Output Damping and process variable damping

When mA Output Process Variable is set to density or temperature, Added Damping interacts with Density Damping or Temperature Damping.

Example: Damping interaction

Configuration:

- mA Output Process Variable = Density
- Density Damping = 1 second
- Added Damping = 2 seconds

Result: A change in density will be reflected in the mA output over a time period that is greater than 3 seconds. The exact time period is calculated by the transmitter according to internal algorithms which are not configurable.

Related information

[Interaction between Density Damping and Added Damping](#)

6.2.4 Configure mA Output Fault Action and mA Output Fault Level

Display	<i>Not available</i>
ProLink III	Device Tools > Configuration > I/O > Outputs > mA Output > mA Output 1 > Fault Action
	Device Tools > Configuration > I/O > Outputs > mA Output > mA Output 2 > Fault Action
Field Communicator	Configure > Manual Setup > Inputs/Outputs > mA Output 1 > mA01 Fault Settings > MA01 Fault Action
	Configure > Manual Setup > Inputs/Outputs > mA Output 2 > MA02 Fault Settings > MA02 Fault Action

Overview

mA Output Fault Action controls the behavior of the mA output if the transmitter encounters an internal fault condition.

Note

For some faults only: If Fault Timeout is set to a non-zero value, the transmitter will not implement the fault action until the timeout has elapsed.

Procedure

1. Set mA Output Fault Action to the desired value.

The default setting is Downscale.

Restriction

If Digital Communications Fault Action is set to NAN (not a number), you cannot set mA Output Fault Action to None. If you try to do this, the device will not accept the configuration.

2. If you set mA Output Fault Action to Upscale or Downscale, set mA Output Fault Level as desired.

Postrequisites

⚠ CAUTION!

If you set mA Output Fault Action to None, be sure to set Digital Communications Fault Action to None. If you do not, the output will not report actual process data, and this may result in measurement errors or unintended consequences for your process.

Options for mA Output Fault Action and mA Output Fault Level

Table 6-3: Options for mA Output Fault Action and mA Output Fault Level

Option	mA output behavior	mA Output Fault Level
Upscale	Goes to the configured fault level	Default: 21.5 mA Range: 21.0 to 21.5 mA
Downscale (default)	Goes to the configured fault level	Default: 3.2 mA Range: 3.2 to 3.6 mA
Internal Zero	Goes to the mA output level associated with a process variable value of 0 (zero), as determined by Lower Range Value and Upper Range Value settings	Not applicable
None	Tracks data for the assigned process variable; no fault action	Not applicable

6.3 Configure the discrete output

The discrete output is used to report specific meter or process conditions. The discrete output parameters control which condition is reported and how it is reported. Depending on your purchase option, your transmitter may have one discrete output or no discrete outputs.

Important

Whenever you change a discrete output parameter, verify all other discrete output parameters before returning the meter to service. In some situations, the transmitter automatically loads a set of stored values, and these values may not be appropriate for your application.

- [Configure Discrete Output Source](#) (Section 6.3.1)
- [Configure Discrete Output Polarity](#) (Section 6.3.2)
- [Configure Discrete Output Fault Action](#) (Section 6.3.3)

6.3.1 Configure Discrete Output Source

Display	OFF-LINE MAINT > OFF-LINE CONFIG > IO > CH B > DO > CONFIG DO > DO SRC
ProLink III	Device Tools > Configuration > I/O > Outputs > Discrete Output
Field Communicator	Configure > Manual Setup > Inputs/Outputs > Discrete Output > DO Source

Overview

Discrete Output Source controls which device condition or process condition is reported via the discrete output.

Procedure

Set Discrete Output Source to the desired option.

The default setting for Discrete Output Source is Fault.

Options for Discrete Output Source

Table 6-4: Options for Discrete Output Source

Option	Label		State	Discrete output voltage
	ProLink III	Field Communicator		
Enhanced Event 1–5	Enhanced Event 1	Enhanced Event 1	ON	Site-specific 0 V
	Enhanced Event 2	Enhanced Event 2	OFF	
	Enhanced Event 3	Enhanced Event 3		
	Enhanced Event 4	Enhanced Event 4		
	Enhanced Event 5	Enhanced Event 5		
Calibration in Progress	Calibration in Progress	Calibration in Progress	ON	Site-specific

Table 6-4: Options for Discrete Output Source (continued)

Option	Label		State	Discrete output voltage
	ProLink III	Field Communicator		
			OFF	0 V
Fault (default)	Fault Indicator	Fault	ON	Site-specific
			OFF	0 V

Important

This table assumes that Discrete Output Polarity is set to Active High. If Discrete Output Polarity is set to Active Low, reverse the voltage values.

6.3.2 Configure Discrete Output Polarity

Display	OFF-LINE MAINT > OFF-LINE CONFIG > IO > CH B > DO > CONFIG DO > DO POLAR
ProLink III	Device Tools > Configuration > I/O > Outputs > Discrete Output
Field Communicator	Configure > Manual Setup > Inputs/Outputs > Discrete Output > DO Polarity

Overview

Discrete outputs have two states: ON (active) and OFF (inactive). Two different voltage levels are used to represent these states. Discrete Output Polarity controls which voltage level represents which state.

Procedure

Set Discrete Output Polarity as desired.

The default setting is Active High.

Options for Discrete Output Polarity

Table 6-5: Options for Discrete Output Polarity



Polarity	Description
Active High 	<ul style="list-style-type: none"> When asserted (condition tied to DO is true), the circuit draws as much current as it can, up to a maximum of 10 mA. When not asserted (condition tied to DO is false), the circuit draws less than 1 mA.

Table 6-5: Options for Discrete Output Polarity (continued)

Polarity	Description
Active Low 	<ul style="list-style-type: none"> When asserted (condition tied to DO is true), the circuit draws less than 1 mA. When not asserted (condition tied to DO is false), the circuit draws as much current as it can, up to a maximum of 10 mA.

6.3.3 Configure Discrete Output Fault Action

Display	<i>Not available</i>
ProLink III	Device Tools > Configuration > Fault Processing
Field Communicator	Configure > Manual Setup > Inputs/Outputs > Discrete Output > DO Fault Action

Overview

Discrete Output Fault Action controls the behavior of the discrete output if the transmitter encounters an internal fault condition.

Note

For some faults only: If Fault Timeout is set to a non-zero value, the transmitter will not implement the fault action until the timeout has elapsed.

CAUTION!

Do not use Discrete Output Fault Action **as a fault indicator. If you do, you may not be able to distinguish a fault condition from a normal operating condition. If you want to use the discrete output as a fault indicator, set** Discrete Output Source **to** Fault **and set** Discrete Output Fault Action **to** None.

Procedure

Set Discrete Output Fault Action as desired.

The default setting is None.

Options for Discrete Output Fault Action

Table 6-6: Options for Discrete Output Fault Action

Label	Discrete output behavior	
	Polarity=Active High	Polarity=Active Low
Upscale	<ul style="list-style-type: none"> Fault: discrete output is ON (site-specific voltage) No fault: discrete output is controlled by its assignment 	<ul style="list-style-type: none"> Fault: discrete output is OFF (0 V) No fault: discrete output is controlled by its assignment
Downscale	<ul style="list-style-type: none"> Fault: discrete output is OFF (0 V) No fault: discrete output is controlled by its assignment 	<ul style="list-style-type: none"> Fault: discrete output is ON (site-specific voltage) No fault: discrete output is controlled by its assignment
None (default)	Discrete output is controlled by its assignment	

Fault indication with the discrete output

To indicate faults via the discrete output, set Discrete Output Source to Fault. Then, if a fault occurs, the discrete output is always ON and the setting of Discrete Output Fault Action is ignored.

6.4 Configure an enhanced event

Display	<i>Not available</i>
ProLink III	Device Tools > Configuration > Events > Enhanced Events
Field Communicator	Configure > Alert Setup > Enhanced Events

Overview

An enhanced event is used to provide notification of process changes. An enhanced event occurs (is ON) if the real-time value of a user-specified process variable moves above (HI) or below (LO) a user-defined setpoint, or in range (IN) or out of range (OUT) with respect to two user-defined setpoints. You can define up to five enhanced events.

Procedure

1. Select the event that you want to configure.
2. Specify Event Type.

Options	Description
HI	$x > A$ The event occurs when the value of the assigned process variable (x) is greater than the setpoint (Setpoint A), endpoint not included.
LO	$x < A$ The event occurs when the value of the assigned process variable (x) is less than the setpoint (Setpoint A), endpoint not included.
IN	$A \leq x \leq B$ The event occurs when the value of the assigned process variable (x) is <i>in range</i> , that is, between Setpoint A and Setpoint B, endpoints included.
OUT	$x \leq A$ or $x \geq B$ The event occurs when the value of the assigned process variable (x) is <i>out of range</i> , that is, less than Setpoint A or greater than Setpoint B, endpoints included.

3. Assign a process variable to the event.
4. Set values for the required setpoints.
 - For HI and LO events, set Setpoint A.
 - For IN and OUT events, set Setpoint A and Setpoint B.
5. (Optional) Configure a discrete output to switch states in response to the event status.

Related information

[Configure Discrete Output Source](#)

6.5 Configure HART/Bell 202 communications

HART/Bell 202 communications parameters support HART communications with the transmitter's primary mA terminals over a HART/Bell 202 network.

- [Configure basic HART parameters](#) (Section 6.5.1)
- [Configure HART variables \(PV, SV, TV, QV\)](#) (Section 6.5.2)
- [Configure burst communications](#) (Section 6.5.3)

6.5.1 Configure basic HART parameters

Display	OFF-LINE MAINT > OFF-LINE CONFIG > HART
ProLink III	Device Tools > Configuration > Meter Information Device Tools > Configuration > Communications > Communications (HART)
Field Communicator	Configure > Manual Setup > HART > Communications

Overview

Basic HART parameters include the HART address, HART tags, and the operation of the primary mA output.

Restrictions

- Your device supports HART 7. If you are using HART 5, HART Long Tag is not available.
- HART Tag, HART Long Tag, and mA Output Action are not configurable from the display.

Procedure

1. Set HART Address to a unique value on your network.

Valid address values are between 0 and 15. The default address (0) is typically used unless you are in a multidrop environment.

Tip

Devices using HART protocol to communicate with the transmitter may use either HART Address or HART Tag (Software Tag) to identify the transmitter. Configure either or both, as required by your other HART devices.

2. Set HART Long Tag to a unique value on your network.
3. Ensure that mA Output Action is configured appropriately.

Options	Description
Enabled (Live)	The primary mA output reports process data as configured. This is the appropriate setting for most applications.
Disabled (Fixed)	The primary mA output is fixed at 4 mA and does not report process data.

Important

If you use ProLink II or ProLink III to set HART Address to 0, the program automatically enables mA Output Action. If you use ProLink II or ProLink III to set HART Address to any other value, the program automatically disables mA Output Action. This is designed to make it easier to configure the transmitter for legacy behavior. Always verify mA Output Action after setting HART Address.

6.5.2 Configure HART variables (PV, SV, TV, QV)

Display	<i>Not available</i>
ProLink III	Device Tools > Configuration > Communications > Communications (HART)
Field Communicator	Configure > Manual Setup > Inputs/Outputs > Variable Mapping

Overview

The HART variables are a set of four variables predefined for HART use. The HART variables include the Primary Variable (PV), Secondary Variable (SV), Tertiary Variable (TV), and Quaternary Variable (QV). You can assign specific process variables to the HART variables, and then use standard HART methods to read or broadcast the assigned process data.

Tip

The Tertiary Variable and Quaternary Variable are also called the Third Variable (TV) and Fourth Variable (FV).

Restriction

On some devices, the PV is fixed to a specific process variable and cannot be changed.

Related information

[Set up the API referral application](#)

Options for HART variables

Table 6-7: Options for HART variables

Process variable	Primary Variable (PV)	Secondary Variable (SV)	Third Variable (TV)	Fourth Variable (QV)
Standard				
Line Density	✓	✓	✓	✓
Line Temperature	✓	✓	✓	✓
Line Temperature (External)	✓	✓	✓	✓
Line Pressure (External)	✓	✓	✓	✓
Drive Gain	✓	✓	✓	✓
Sensor Time Period	✓	✓	✓	✓
Volume Flow Rate (External)	✓	✓	✓	✓
Mass Flow Rate (Calculated)	✓	✓	✓	✓
User-Defined Calculation Output	✓	✓	✓	✓
Board Temperature			✓	✓
Input Voltage			✓	✓
API referral				
Referred Density (API)	✓	✓	✓	✓
Concentration measurement				
Specific Gravity	✓	✓	✓	✓
Concentration	✓	✓	✓	✓
Referred Density (Concentration)	✓	✓	✓	✓

Table 6-7: Options for HART variables (continued)

Process variable	Primary Variable (PV)	Secondary Variable (SV)	Third Variable (TV)	Fourth Variable (QV)
Net Mass Flow	✓	✓	✓	✓
Net Volume Flow	✓	✓	✓	✓

Interaction of HART variables and transmitter outputs

The HART variables are automatically reported through specific transmitter outputs. They may also be reported through HART burst mode, if enabled on your transmitter.

Restriction

On some devices, the PV and the primary mA output are fixed to a specific process variable and cannot be changed.

Table 6-8: HART variables and transmitter outputs

HART variable	Reported via	Comments
Primary Variable (PV)	Primary mA output	If one assignment is changed, the other is changed automatically, and vice versa.
Secondary Variable (SV)	Secondary mA output, if present on your transmitter	If you have a secondary mA output: If one assignment is changed, the other is changed automatically. If you do not have a secondary mA output: The SV must be configured directly, and the value of the SV is available only via digital communications.
Tertiary Variable (TV)	Not associated with an output	The TV must be configured directly, and the value of the TV is available only via digital communications.
Quaternary Variable (QV)	Not associated with an output	The QV must be configured directly, and the value of the QV is available only via digital communications.

6.5.3 Configure burst communications

Burst mode is a mode of communication during which the transmitter regularly broadcasts HART digital information to the network via the primary mA output.

Restriction

Burst communications, including trigger mode and event notification, are not available on HART/RS-485. These features are supported only on HART/Bell 202.

- [Configure HART burst messages](#)
- [Configure HART trigger mode](#)
- [Configure HART event notification](#)

Configure HART burst messages

Display	<i>Not available</i>
ProLink III	Device Tools > Configuration > Communications > Communications (HART)
Field Communicator	Configure > Manual Setup > HART > Burst Mode

Overview

Burst messages contain information on process variables or transmitter status. You can configure up to three burst messages. Each message can contain different information. Burst messages also provide the mechanism for trigger mode and event notification.

Restriction

If you are using a HART 5 host, only one burst message is supported.

Procedure

1. Navigate to the burst message you want to configure.
2. Enable the burst message.
3. Set Burst Option to the desired content.

Table 6-9: Options for burst message contents

HART command	Label		Description
	ProLink III	Field Communicator	
1	Source (Primary Variable)	Primary Variable	The transmitter sends the primary variable (PV) in the configured measurement units in each burst message (e.g., 14.0 g/sec, 13.5 g/sec, 12.0 g/sec).
2	Primary Variable (Percent Range/Current)	Pct Range/Current	The transmitter sends the PV's actual mA level and the PV's percent of range in each burst message (e.g., 11.0 mA 25%).
3	Process Variables/Current	Process Vars/Current	The transmitter sends the PV's actual milliamp reading and the PV, SV, TV, and QV values in measurement units in each burst message (e.g., 11.8 mA, 50 g/sec, 23 °C, 50 g/sec, 0.0023 g/cm ³).
9	Read Device Variables with Status	Device Variables with Status	The transmitter sends up to eight user-specified process variables in each burst message.
33	Transmitter Variables	Field Device Vars	The transmitter sends four user-specified process variables in each burst message.
48	Read Additional Transmitter Status	Read Additional Device Status	The transmitter sends expanded device status information in each burst message.

4. Depending on your choice, select the four or eight user-specified variables for the burst message, or set the HART variables as desired.

Important

If you change the HART Primary Variable (PV) or Secondary Variable (SV), the process variables assigned to the primary mA output and the secondary mA output (if applicable) are automatically changed to match. The PV cannot be changed on devices with fixed mA output assignments.

Configure HART trigger mode

Display	<i>Not available</i>
ProLink III	Device Tools > Configuration > Communications > Communications (HART)
Field Communicator	Configure > Manual Setup > HART > Burst Mode > Burst Message x > Configure Update Rate

Overview

Trigger mode uses the burst message mechanism to indicate that a process variable has changed. When trigger mode is implemented, the bursting interval (HART update rate) changes if Primary Variable or Burst Variable 0 moves above or below the user-specified trigger level. You can set up a different trigger on each burst message.

Restriction

This feature is available only with a HART 7 host.

Prerequisites

Before you can configure trigger mode, the corresponding HART burst message must be enabled.

Procedure

1. Select the burst message for which you will set up trigger mode.
2. Set Trigger Mode to the type of trigger you want to use.

Option	Description
Continuous	The burst message is sent at Default Update Rate. The burst interval is not affected by changes in process variables.
Falling	<ul style="list-style-type: none"> • When the specified process variable is above Trigger Level, the burst message is sent at Default Update Rate. • When the specified process variable is below Trigger Level, the burst message is sent at Update Rate.
Rising	<ul style="list-style-type: none"> • When the specified process variable is below Trigger Level, the burst message is sent at Default Update Rate. • When the specified process variable is above Trigger Level, the burst message is sent at Update Rate.

Option	Description
Windowed	<p>This option is used to communicate that the process variable is changing rapidly. Trigger Level defines a deadband around the most recently broadcast value.</p> <ul style="list-style-type: none"> • If the process variable stays within this deadband, the burst message is sent at Default Update Rate. • If the process variable moves outside this deadband in either direction, the burst message is sent at Update Rate.
On Change	<ul style="list-style-type: none"> • If any value in the burst message changes, the burst message is sent at Update Rate. • If no values change, the burst message is sent at Default Update Rate.

3. Ensure that Primary Variable or Burst Variable 0 is set to the variable that will activate the trigger. If it is not, reconfigure the burst message contents.
4. Set Trigger Level to the value of the process variable at which the trigger will be activated.
5. Set Default Update Rate to the burst interval to be used when the trigger is not active.
6. Set Update Rate to the burst interval to be used when the trigger is active.

Configure HART event notification

Display	<i>Not available</i>
ProLink III	Device Tools > Configuration > Communications > Communications (HART) > Event Notification
Field Communicator	Configure > Manual Setup > HART > Event Notification

Overview

Event notification uses the burst message mechanism to indicate that an alert has occurred. When event notification is enabled and one or more of the selected alerts occurs, each active burst message will broadcast HART Command 119 until the condition is acknowledged by a HART master.

Tip

Event notification affects only HART burst messages. Whether an alert is selected for event notification or not, alert severity, alert status (active or inactive), fault timeout, and alert acknowledgment operate as normal.

Restriction

This feature is available only with a HART 7 host.

Prerequisites

If you are using the Field Communicator, you must enable a burst message before you can configure event notification.

Procedure

1. Enable event notification.
2. Select all desired alerts.

If one or more of the selected alerts occurs, each active burst message will broadcast HART Command 119 until the alert is acknowledged by a HART master.

3. Set Trigger Interval as desired.

Trigger Interval controls the delay before HART Command 119 is broadcast.

- Default: 0 seconds
- Range: 0.5 to 3600 seconds

Trigger Interval begins when the transmitter detects the alert condition. When Trigger Interval expires:

- If the alert is still active, HART Command 119 is broadcast.
- If the alert is not active, no message is broadcast.

Tip

If you set Trigger Interval to 0, HART Command 119 is broadcast as soon as the alert is detected.

4. Set Retry Rate as desired.

Retry Rate controls the rate at which HART Command 119 is broadcast when event notification is active.

- Default: 0.5 seconds

5. Set Maximum Update Time as desired.

Maximum Update Time controls the rate at which HART Command 119 is broadcast when event notification is not active.

- Default: 60 seconds

6.6 Configure Modbus communications

Display	OFF-LINE MAINT > OFF-LINE CONFIG > CONFIG MBUS
ProLink III	Device Tools > Configuration > Communications > Communications (Modbus)
Field Communicator	<i>Not available</i>

Overview

Modbus communications parameters control Modbus communications with the transmitter.

Modbus support is implemented on the RS-485 physical layer via the RS-485 terminals.

Important

Your device automatically accepts all connection requests within the following ranges:

- Protocol: Modbus RTU (8-bit) or Modbus ASCII (7-bit) unless Modbus ASCII Support is disabled
- Parity: odd or even
- Stop bits: 1 or 2
- Baud: 1200, 2400, 4800, 9600, 19200, 38400

You do not need to configure these communications parameters on the device.

Procedure

1. Enable or disable Modbus ASCII Support as desired.

The setting of this parameter controls the range of valid Modbus addresses for your device.

Modbus ASCII support	Available Modbus addresses
Disabled	1–127, excluding 111 (111 is reserved to the service port)
Enabled	1–15, 32–47, 64–79, and 96–110

2. Set Modbus Address to a unique value on the network.
3. Set Floating-Point Byte Order to match the byte order used by your Modbus host.

Code	Byte order
0	1–2 3–4
1	3–4 1–2
2	2–1 4–3
3	4–3 2–1

See the following table for the bit structure of bytes 1, 2, 3, and 4.

Table 6-10: Bit structure of floating-point bytes

Byte	Bits	Definition
1	SEEEEEEE	S=Sign E=Exponent
2	EMMMMMMM	E=Exponent M=Mantissa
3–4	MMMMMMMM	M=Mantissa

4. (Optional) Set Additional Communications Response Delay in *delay units*.

A delay unit is 2/3 of the time required to transmit one character, as calculated for the port currently in use and the character transmission parameters.

Additional Communications Response Delay is used to synchronize Modbus communications with hosts that operate at a slower speed than the device. The value specified here will be added to each response the device sends to the host.

- Default: 0
- Range: 0 to 255

Tip

Do not set Additional Communications Response Delay unless required by your Modbus host.

6.7 Configure Digital Communications Fault Action

Display	<i>Not available</i>
ProLink III	Device Tools > Configuration > Fault Processing
Field Communicator	Configure > Alert Setup > I/O Fault Actions > Digital Communication Fault Action

Overview

Digital Communications Fault Action specifies the values that will be reported via digital communications if the device encounters an internal fault condition.

Procedure

Set Digital Communications Fault Action as desired.

The default setting is None.

Restrictions

- If mA Output Fault Action is set to None, Digital Communications Fault Action should also be set to None. If you do not, the output will not report actual process data, and this may result in measurement errors or unintended consequences for your process.
 - If you set Digital Communications Fault Action to NAN, you cannot set mA Output Fault Action to None. If you try to do this, the transmitter will not accept the configuration.
-

6.7.1 Options for Digital Communications Fault Action

Table 6-11: Options for Digital Communications Fault Action

Label		Description
ProLink III	Field Communicator	
Upscale	Upscale	<ul style="list-style-type: none"> • Process variable values indicate that the value is greater than the upper sensor limit.
Downscale	Downscale	<ul style="list-style-type: none"> • Process variable values indicate that the value is lower than the lower sensor limit.

Table 6-11: Options for Digital Communications Fault Action (continued)

Label		Description
ProLink III	Field Communicator	
Zero	IntZero-All 0	<ul style="list-style-type: none"> Density is reported as 0. Temperature is reported as 0 °C, or the equivalent if other units are used (e.g., 32 °F). Drive gain is reported as measured.
Not a Number	Not-a-Number	<ul style="list-style-type: none"> Process variables are reported as IEEE NAN. Drive gain is reported as measured. Modbus scaled integers are reported as Max Int.
None	None (default)	<ul style="list-style-type: none"> All process variables are reported as measured.

7 Complete the configuration

Topics covered in this chapter:

- [Test or tune the system using sensor simulation](#)
- [Back up transmitter configuration](#)
- [Enable HART security](#)

7.1 Test or tune the system using sensor simulation

Display	<i>Not available</i>
ProLink III	Device Tools > Diagnostics > Testing > Sensor Simulation
Field Communicator	Service Tools > Simulate > Simulate Sensor

Overview

Use sensor simulation to test the system's response to a variety of process conditions, including boundary conditions, problem conditions, or alert conditions, or to tune the loop.

Procedure

1. Enable sensor simulation.
2. Set the process variables to the desired test values.
3. Observe the system response to the simulated values and make any appropriate changes to the transmitter configuration or to the system.
4. Modify the simulated values and repeat.
5. When you have finished testing or tuning, disable sensor simulation.

7.2 Back up transmitter configuration

ProLink III provides a configuration upload/download function which allows you to save configuration sets to your PC. This allows you to back up and restore your transmitter configuration. This is also a convenient way to replicate a configuration across multiple devices.

Restriction

This function is not available with any other communications tools.

Procedure

1. Choose Device Tools > Configuration Transfer > Save or Load Configuration Data.
2. In the Configuration groupbox, select the configuration data you want to save.
3. Click Save, then specify a file name and location on your computer.
4. Click Start Save.

The backup file is saved to the specified name and location. It is saved as a text file and can be read using any text editor.

7.3 Enable HART security

When HART security is enabled, HART protocol cannot be used to write any data to the device. This prevents changes to configuration via HART. It does not prevent changes to configuration using any other protocol or method.

Tip

Do not enable HART security unless it is specifically required for your meter. Most installations do not enable HART security.

Prerequisites

- Strap wrench
- 3 mm hex key

Procedure

1. Power down the meter.
2. Using the strap wrench, loosen the grub screws and remove the transmitter end-cap.

Figure 7-1: Transmitter with end-cap removed

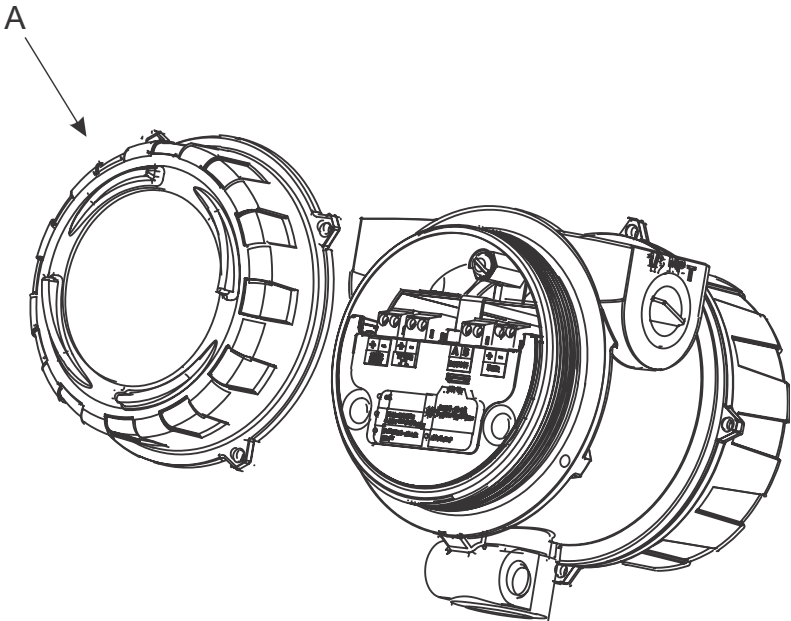

A. Transmitter end-cap

- 3. Using the hex key, remove the safety spacer.

Figure 7-2: Transmitter with end-cap and safety spacer removed

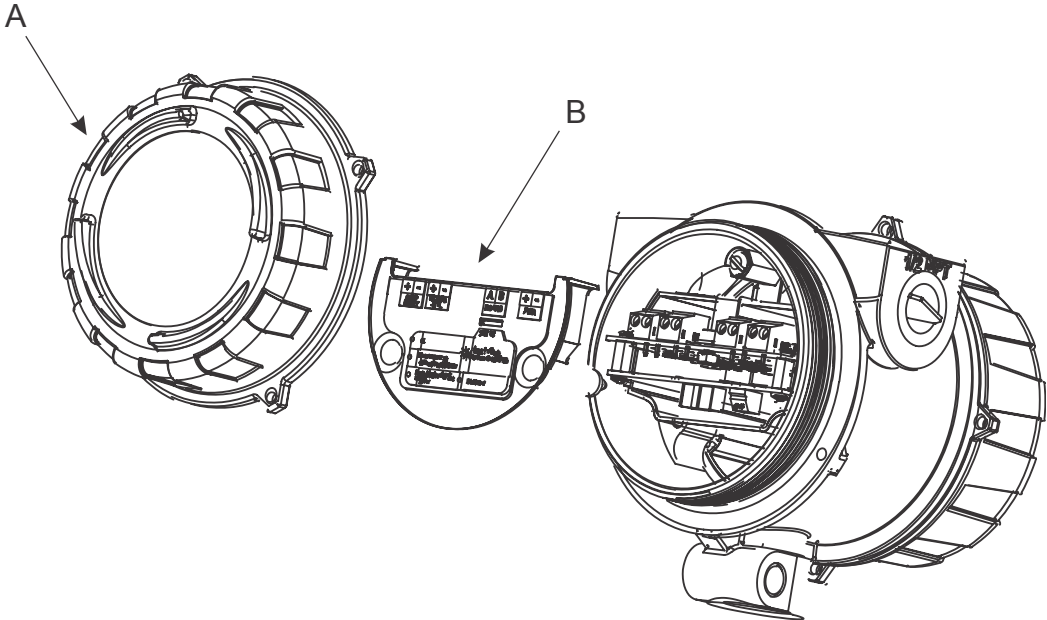

A. Transmitter end-cap
B. Safety spacer

- 4. Move the HART security switch to the ON position (down).

The HART security switch is the switch on the left.

Figure 7-3: HART security switch

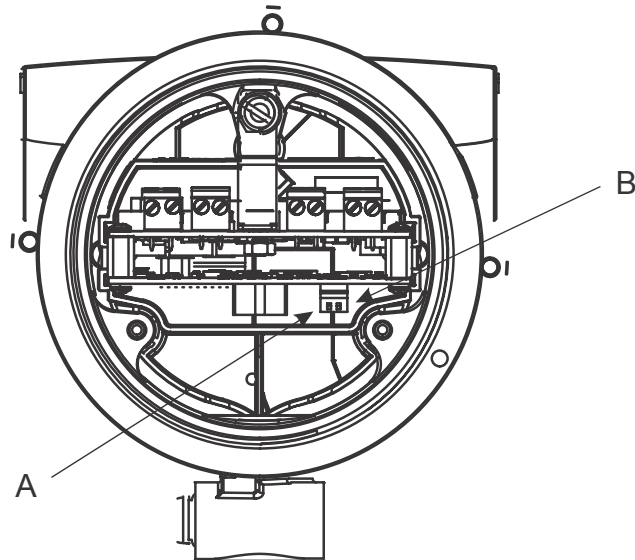

- A. HART security switch
- B. Unused

-
5. Replace the safety spacer and end-cap.
 6. Power up the meter.

Part III

Operations, maintenance, and troubleshooting

Chapters covered in this part:

- *Transmitter operation*
- *Measurement support*
- *Troubleshooting*

8 Transmitter operation

Topics covered in this chapter:

- [Record the process variables](#)
- [View process variables and diagnostic variables](#)
- [View and acknowledge status alerts](#)

8.1 Record the process variables

Micro Motion suggests that you make a record of specific process variable measurements, including the acceptable range of measurements, under normal operating conditions. This data will help you recognize when the process or diagnostic variables are unusually high or low, and may help you diagnose and troubleshoot application issues.

Procedure

Record the following process and diagnostic variables, under normal operating conditions.

Variable	Measurement		
	Typical average	Typical high	Typical low
Line Density			
Line Temperature			
Sensor Time Period			
Drive Gain			

8.2 View process variables and diagnostic variables

Process variables provide information about the state of the process fluid. Diagnostic variables provide data about meter operation. This information can be used to understand and troubleshoot your process.

- [View process variables using the display](#) (Section 8.2.1)
- [View process variables and other data using ProLink III](#) (Section 8.2.2)
- [View process variables using the Field Communicator](#) (Section 8.2.3)

8.2.1 View process variables using the display

View the desired process variable(s).

The display shows the configured display variables. For each display variable, the display reports the abbreviated name of the process variable (for example, DENS for density), the current value of that process variable, and the associated unit of measure (for example, G/CM3).

If Auto Scroll is enabled, the display cycles through the display variables, showing each display variable for a user-specified number of seconds. Whether or not Auto Scroll is enabled, you can activate Select to move to the next display variable.

Figure 8-1: Transmitter display features

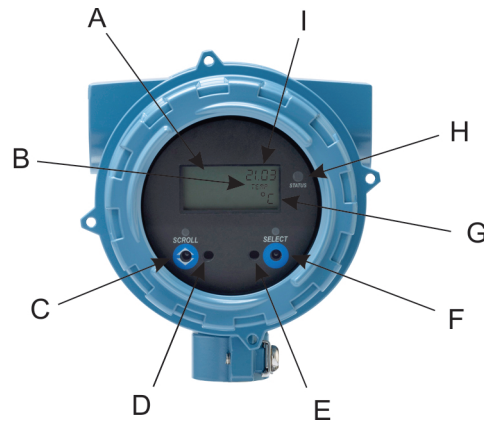

- A. Display (LCD panel)
- B. Process variable
- C. Scroll optical switch
- D. Optical switch indicator: turns red when Scroll is activated
- E. Optical switch indicator: turns red when Select is activated
- F. Select optical switch
- G. Unit of measure for process variable
- H. Status LED
- I. Current value of process variable

8.2.2 View process variables and other data using ProLink III

Monitor process variables, diagnostic variables, and other data to maintain process quality.

ProLink III automatically displays process variables, diagnostic variables, and other data on the main screen.

Tip

ProLink III allows you to choose the process variables that appear on the main screen. You can also choose whether to view data in Analog Gauge view or digital view, and you can customize the gauge settings. For more information, see the ProLink III user manual.

8.2.3 View process variables using the Field Communicator

Monitor process variables to maintain process quality.

- To view current values of basic process variables, choose Overview.
- To view a more complete set of process variables, plus the current state of the outputs, choose Service Tools > Variables.

8.3 View and acknowledge status alerts

The transmitter posts status alerts whenever a process variable exceeds its defined limits or the transmitter detects a fault condition. You can view active alerts, and you can acknowledge alerts. Acknowledging alerts is not required.

- [View and acknowledge alerts using the display](#) (Section 8.3.1)
- [View and acknowledge alerts using ProLink III](#) (Section 8.3.2)
- [View alerts using the Field Communicator](#) (Section 8.3.3)

8.3.1 View and acknowledge alerts using the display

You can view a list containing all alerts that are active, or inactive but unacknowledged.

Note

Only Fault and Informational alerts are listed. The transmitter automatically filters out alerts with Status Alert Severity set to Ignore.

Prerequisites

Operator access to the alert menu must be enabled (default setting). If operator access to the alert menu is disabled, you must use another method to view or acknowledge status alerts.

Procedure

See [Figure 8-2](#).

Figure 8-2: Using the display to view and acknowledge the status alerts

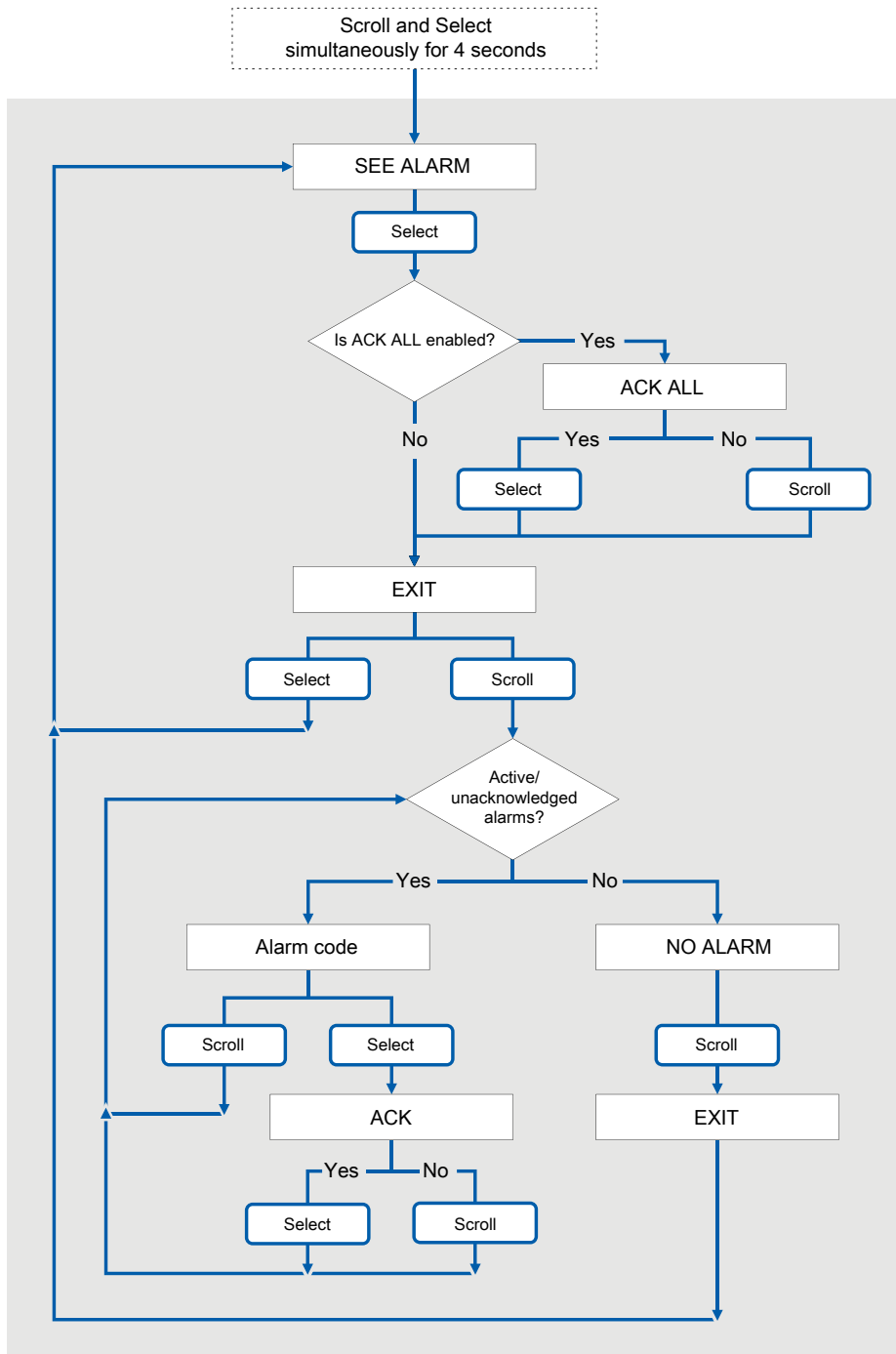

Postrequisites

- To clear A010, A011, A012, A013 alerts, you must correct the problem, acknowledge the alert, then repeat the calibration.
- To clear A001, A002, A029, A031 alerts, you must correct the problem, acknowledge the alert, then power-cycle the transmitter.
- For all other alerts:
 - If the alert is inactive when it is acknowledged, it will be removed from the list.
 - If the alert is active when it is acknowledged, it will be removed from the list when the alert condition clears.

Related information

[Alert data in transmitter memory](#)

8.3.2 View and acknowledge alerts using ProLink III

You can view a list containing all alerts that are active, or inactive but unacknowledged. From this list, you can acknowledge individual alerts or choose to acknowledge all alerts at once.

1. View alerts on the ProLink III main screen under Alerts. If the alerts are not displayed, choose Device Tools > Alerts.

All active or unacknowledged alerts are listed, and displayed according to the following categories:

Category	Description
Failed: Fix Now	A meter failure has occurred and must be addressed immediately.
Maintenance: Fix Soon	A condition has occurred that can be fixed at a later time.
Advisory: Informational	A condition has occurred, but requires no maintenance from you.

Notes

- All fault alerts are displayed in the Failed: Fix Now category.
 - All information alerts are displayed in either the Maintenance: Fix Soon category or the Advisory: Informational category. The category assignment is hard-coded.
 - The transmitter automatically filters out alerts with Alert Severity set to Ignore.
2. To acknowledge a single alert, check the Ack checkbox for that alert. To acknowledge all alerts at once, click Ack All.

Postrequisites

- To clear A010, A011, A012, A013 alerts, you must correct the problem, acknowledge the alert, then repeat the calibration.
- To clear A001, A002, A029, A031 alerts, you must correct the problem, acknowledge the alert, then power-cycle the transmitter.

- For all other alerts:
 - If the alert is inactive when it is acknowledged, it will be removed from the list.
 - If the alert is active when it is acknowledged, it will be removed from the list when the alert condition clears.

Related information

Alert data in transmitter memory

8.3.3 View alerts using the Field Communicator

You can view a list containing all alerts that are active, or inactive but unacknowledged.

- To view active or unacknowledged alerts, choose Service Tools > Alerts.
- All active alerts and unacknowledged alerts are listed.

Note

Only Fault and Informational alerts are listed. The transmitter automatically filters out alerts with Status Alert Severity set to Ignore.

- To refresh the list, choose Service Tools > Alerts > Refresh Alerts.

Related information

Alert data in transmitter memory

8.3.4 Alert data in transmitter memory

The transmitter maintains three sets of data for every alert that is posted.

For each alert occurrence, the following three sets of data are maintained in transmitter memory:

- Alert List
- Alert Statistics
- Recent Alerts

Table 8-1: Alert data in transmitter memory

Alert data structure	Transmitter action if condition occurs	
	Contents	Clearing
Alert List	As determined by the alert status bits, a list of: <ul style="list-style-type: none"> • All currently active alerts • All previously active alerts that have not been acknowledged 	Cleared and regenerated with every transmitter power cycle

Table 8-1: Alert data in transmitter memory (continued)

Alert data structure	Transmitter action if condition occurs	
	Contents	Clearing
Alert Statistics	One record for each alert (by alert number) that has occurred since the last master reset. Each record contains: <ul style="list-style-type: none"> • A count of the number of occurrences • Timestamps for the most recent posting and clearing 	Not cleared; maintained across transmitter power cycles
Recent Alerts	50 most recent alert postings or alert clearings	Not cleared; maintained across transmitter power cycles

9 Measurement support

Topics covered in this chapter:

- *Perform the inline calibration check procedure*
- *Perform the Known Density Verification procedure*
- *Adjust density measurement with Density Offset or Density Meter Factor*
- *Perform density offset calibration*
- *Perform temperature calibration*
- *Adjust concentration measurement with Trim Offset*
- *Adjust concentration measurement with Trim Slope and Trim Offset*
- *Set up user-defined calculations*

9.1 Perform the inline calibration check procedure

Use the inline calibration check to compare the meter's calculated density value of a known fluid at process conditions to a lab measurement of the same fluid at reference conditions.

If the meter passes the check, the meter is performing as expected. If the meter fails the check, either a density offset may be required, or there has been a change to the meter that is affecting performance.

If at anytime during this procedure the density measurement fluctuates, remove the meter from the control loop.

Tip

Use the inline calibration check as an initial diagnostic to validate meter performance. If there is a change to the meter that affects performance (such as corrosion, erosion or coating), the inline calibration check will fail. If the check fails, either an offset can be applied, or a more extensive evaluation is recommended.

Restriction

To use the inline calibration check, the fluid measured by the sensor must be either water or a known user fluid with a respective concentration measurement matrix or API table.

Prerequisites

- The fluid being tested must be either water or a known fluid.
- If using water, you need to know the water density, temperature, and pressure that were measured in the laboratory.
- If using a fluid other than water, your meter must have concentration measurement or API referral enabled.
- If using a fluid other than water with API referral:

- Know the density at reference conditions that was measured in the laboratory.
- Make sure the correct API table is selected.
- If using a fluid other than water with concentration measurement:
 - Know the density at reference conditions that was measured in the laboratory.
 - Make sure the associated concentration measurement curve is loaded.
 - Make sure that the Active Matrix is set to the matrix for the fluid you want to measure.

 **CAUTION!**

Measured density values will fluctuate while the inline calibration check procedure is running.

Related information

Perform the inline calibration check using ProLink III

Perform the inline calibration check using the Field Communicator

9.1.1 Perform the inline calibration check using ProLink III

1. Read [Section 9.1](#) if you have not done so already.
2. Choose Device Tools > Diagnostics > Inline Calibration Check.
3. Select Water or User for Fluid, and click Apply.

To test a fluid other than water, select User.

4. Enter the appropriate laboratory reference values.
 - For Water: Enter the laboratory reference values for Water Density, Reference Temperature, and Reference Pressure.
 - For User with API referral: Enter the value for Laboratory Density at Reference Conditions.

The values for Reference Temperature and Reference Pressure should already be populated from the API table.

- For User with concentration measurement: Enter the value for Laboratory Density at Reference Conditions.

The values for Active Matrix and Reference Temperature should already be populated.

5. Click Check Calibration.
6. Check the results at the bottom of the screen.
 - If the calibration check passed, no action is required.
 - If the calibration check failed, run the Density Offset Calibration wizard to apply the calculated offset at reference conditions.

Tip

If the inline calibration check failed, continue to monitor the density performance on regular intervals. If the inline calibration check continues to fail, further diagnosis is required. Remove the meter from the line and run the Known Density Verification procedure.

Related information

Perform the Known Density Verification procedure using ProLink III

Perform the Known Density Verification procedure using the Field Communicator

9.1.2 Perform the inline calibration check using the Field Communicator

1. Read [Section 9.1](#) if you have not done so already.
2. Navigate to the inline calibration check: Service Tools > Maintenance > Verification > Inline Calibration Check.
3. Enter the laboratory reference value.
4. Press OK.

Wait a few seconds while the calibration is performed.

5. Choose Results and check the values.
 - If the calibration check passed, no action is required.
 - If the calibration check failed, run the density offset calibration to apply the calculated offset at reference conditions.

Tip

If the inline calibration check failed, continue to monitor the density performance on regular intervals. If the inline calibration check continues to fail, further diagnosis is required. Remove the meter from the line and run the Known Density Verification procedure.

9.2 Perform the Known Density Verification procedure

The Known Density Verification procedure is used to verify that the meter's current operation matches the factory baseline. If the meter passes the test, the meter does not have any physical problems such as denting, bending, twisting, erosion, or corrosion.

Prerequisites

Check calibration integrity inline first by running water or a known fluid through the system using the factory measurements. Verify that the reported density is correct. If it is not correct, continue with a KDV check and the following prerequisites.

1. Power down the meter, remove the meter from the process, and place it in a protected stable environment.

2. Minimize variation in ambient temperature.
3. Eliminate or minimize vibration.
4. Ensure that the meter is clean. Check for deposition on the tines.
5. Power up the meter.
 - [Perform the Known Density Verification procedure using the display](#) (Section 9.2.1)
 - [Perform the Known Density Verification procedure using ProLink III](#) (Section 9.2.2)
 - [Perform the Known Density Verification procedure using the Field Communicator](#) (Section 9.2.3)

9.2.1 Perform the Known Density Verification procedure using the display

Procedure

1. Read [Section 9.2](#) if you have not done so already.
2. Enter the Off-Line Maintenance menu and scroll to RUN KDV.
3. Set Alt to the value that is closest to the altitude of your meter, measured from sea level.

- a. Activate SCROLL to move through the list of options.

The options are 0000, 1000 feet, 2000 feet, 3000 feet, 4000 feet, 5000 feet, 6000 feet, 500 meters, 1000 meters, and 2000 meters.

- b. When the correct value appears, activate SELECT and save the value to the meter.

4. When START KDV appears, activate SELECT.
5. Wait while the meter collects and analyzes process data.

This step should be complete in approximately 20 seconds.

6. Check the results in the Results data display.
 - If all process variables passed the tests, no action is required. Click Close to exit the wizard.
 - If one or more process variables failed the test:
 - For problems with Line Temperature, verify that the ambient temperature of the meter is stable, and that the meter temperature has stabilized in the test location. Then retry the Known Density Verification procedure.
 - For problems with Verification Time Period Signal or Drive Gain, ensure that the meter is clean and dry. Then retry the Known Density Verification procedure.
 - If the Known Density Verification procedure continues to fail, contact Micro Motion customer service.

9.2.2 Perform the Known Density Verification procedure using ProLink III

1. Read [Section 9.2](#) if you have not done so already.
2. Choose Device Tools > Diagnostics > Known Density Verification.
3. (Optional) Enter identification data.
4. Set Altitude to the value that is closest to the altitude of your meter, measured from sea level.

Valid values are 0000 to 6000 feet, and 0000 to 2000 meters.

5. Click Start, then wait while the meter collects and analyzes process data.
This step should be complete in approximately 20 seconds.
6. Check the results in the Results data display.
 - If all process variables passed the tests, no action is required. Click Close to exit the wizard.
 - If one or more process variables failed the test:
 - For problems with Line Temperature, verify that the ambient temperature of the meter is stable, and that the meter temperature has stabilized in the test location. Then retry the Known Density Verification procedure.
 - For problems with Verification Time Period Signal or Drive Gain, ensure that the meter is clean and dry. Then retry the Known Density Verification procedure.
 - If the Known Density Verification procedure continues to fail, contact Micro Motion customer service.

9.2.3 Perform the Known Density Verification procedure using the Field Communicator

1. Read [Section 9.2](#) if you have not done so already.
2. Choose Service Tools > Maintenance > Verification > Known Density Verification.
3. Set Altitude to the value that is closest to the altitude of your meter, measured from sea level.

Valid values are 0000 to 6000 feet, and 0000 to 2000 meters.

4. Click Next to start the procedure.
5. Wait while the meter collects and analyzes process data.
This step should be complete in approximately 20 seconds.
6. Check the results in the Results data display.
 - If all process variables passed the tests, no action is required. Click Close to exit the wizard.
 - If one or more process variables failed the test:

- For problems with Line Temperature, verify that the ambient temperature of the meter is stable, and that the meter temperature has stabilized in the test location. Then retry the Known Density Verification procedure.
- For problems with Verification Time Period Signal or Drive Gain, ensure that the meter is clean and dry. Then retry the Known Density Verification procedure.
- If the Known Density Verification procedure continues to fail, contact Micro Motion customer service.

9.3 Adjust density measurement with Density Offset or Density Meter Factor

You can adjust the reported density measurement by modifying the value for Density Offset or Density Meter Factor. The measured density value is always multiplied by the density meter factor. The density offset is always added to the result.

The default value for Density Meter Factor is 1.0. The default value for Density Offset is 0. Accordingly, the default values have no effect on the reported density value.

Important

Density Offset and Density Meter Factor improve measurement accuracy only when the line temperature and line pressure of the sample are close to the line temperature and line pressure of the process.

Tip

If the density offset calibration procedure is available, use it to calculate a density offset value that is corrected to reference temperature and reference pressure. Density offset calibration is the preferred method to adjust density measurement.

Restriction

You cannot enter a density offset from the display. If you want to change the density offset manually, you must use ProLink III or the Field Communicator.

Prerequisites

You will need an external density measurement method that is highly accurate.

Ensure that your process is stable during the sampling procedure. Minimize variation in density, temperature, flow rate, and fluid composition. Minimize aeration.

Procedure

1. Take a density reading from the device.
 - a. Ensure that line temperature and line pressure are at typical operating levels.
 - b. Record the line temperature and line pressure.
 - c. Record the measured density.

2. Immediately after the previous step, take a sample from a location as close to the device as possible.
3. Using the external measurement method, measure the density of the sample at line temperature and line pressure.
4. Use the following equation to calculate an appropriate value for Density Offset or Density Meter Factor.

$$\rho_{\text{Lab}} = (\rho_{\text{Line}} \times \text{DensityMeterFactor}) + \text{DensityOffset}$$

Tip

In most cases, you will calculate and set only one parameter. Follow the guidelines established for your site.

5. If you are using the offset to adjust density measurement, set Density Offset to the calculated value.
 - Using the display: Not available
 - Using ProLink III: Device Tools > Configuration > Process Measurement > Line Density > Density Offset
 - Using the Field Communicator: Configure > Manual Setup > Measurements > Density > Density Offset

The default value for Density Offset is 0. The range is unlimited.

6. If you are using the meter factor to adjust density measurement, set Density Meter Factor to the calculated value.
 - Using the display: OFF-LINE MAINT > OFF-LINE CAL > DENS MTR F
 - Using ProLink III: Device Tools > Configuration > Process Measurement > Line Density > Density Meter Factor
 - Using the Field Communicator: Configure > Manual Setup > Measurements > Density > Meter Factor

The default value for Density Meter Factor is 1.0. The recommended range is 0.8 to 1.2. If your calculated meter factor is outside this range, contact Micro Motion customer service.

9.4 Perform density offset calibration

Density offset calibration is used to verify or adjust the value of Density Offset. Density Offset is always added to the measured density value after the density meter factor is applied, and before other processing is performed.

The default value of Density Offset is 0.

Restriction

Density offset calibration is available only when API referral or concentration measurement is enabled on your meter. If neither of these is enabled, Density Offset must be entered manually.

Tip

Density offset calibration is the preferred method for calculating a density offset, because the procedure automatically corrects the data to reference temperature and reference pressure. If this procedure is available on your device, use it and do not set Density Offset manually.

Prerequisites

- Ensure that your process is stable during the calibration procedure. Minimize variation in density, temperature, flow rate, and fluid composition. Minimize aeration.
- If concentration measurement is enabled on your meter, ensure that Active Matrix is set to the matrix that you want to calibrate.
- Following the procedures defined in ASTM 1298 or API 555, obtain a laboratory reference value for the density of your process fluid at reference temperature and reference pressure.
- [Perform density offset calibration using the display](#) (Section 9.4.1)
- [Perform density offset calibration using ProLink III](#) (Section 9.4.2)
- [Perform density offset calibration using the Field Communicator](#) (Section 9.4.3)

9.4.1 Perform density offset calibration using the display

1. Read [Section 9.4](#) if you have not done so already.
2. Navigate to the Density Offset Calibration wizard: OFF-LINE MAINT > OFF-LINE CAL > DENS CAL OFFSET and activate Select.

If concentration measurement is enabled, the active matrix is displayed. Activate Scroll to continue. The current reference temperature is displayed.

3. Activate Scroll to move to the next step.
4. Enter the laboratory reference density and save it to the transmitter.
5. Activate Select to apply the offset, and wait for a few seconds while the calibration process is performed.

If the calibration succeeded, the calculated density offset is displayed.

If the calibration failed, Density Offset is reset to the original value.

- Verify your laboratory reference value.
 - Ensure that your process was stable during the entire procedure.
 - Repeat the calibration.
6. Activate Scroll to view the referred density value.
 - For concentration measurement, Referred Density (Concentration) is displayed.
 - For API referral, Referred Density (API) is displayed.
 7. To exit the calibration, activate Scroll, then activate Select.

9.4.2 Perform density offset calibration using ProLink III

1. Read [Section 9.4](#) if you have not done so already.
2. Navigate to the Density Offset Calibration wizard: Device Tools > Calibration > Density Offset > Density Offset Calibration.
3. Enter the laboratory reference value for density.
4. Click Apply Offset and wait for a few seconds while the calibration process is performed.
5. For API referral: Check the values displayed in the Density Offset and Referred Density (API) fields.

If the calibration succeeded:

- Density Offset displays the updated value for this parameter.
- Referred Density (API) shows this process variable with the new density offset applied. This value should match the laboratory reference value.

If the calibration failed, Density Offset is reset to the original value.

- Verify your laboratory reference value.
- Ensure that your process was stable during the entire procedure.
- Repeat the calibration.

6. For concentration measurement: Check the values displayed in the Density Offset and Referred Density (Concentration) fields.

If the calibration succeeded:

- Density Offset displays the updated value for this parameter.
- Referred Density (Concentration) shows this process variable with the new density offset applied. This value should match the laboratory reference value.

If the calibration failed, Density Offset is reset to the original value.

- Verify your laboratory reference value.
- Ensure that your process was stable during the entire procedure.
- Ensure that the active concentration matrix is valid.
- Repeat the calibration.

9.4.3 Perform density offset calibration using the Field Communicator

1. Read [Section 9.4](#) if you have not done so already.
2. Navigate to the Density Offset Calibration method: Service Tools > Maintenance > Calibration > Density Offset Calibration.
3. Enter the laboratory reference value.
4. Press OK and wait for a few seconds while the calibration process is performed.

9.5 Perform temperature calibration

Temperature calibration establishes the relationship between the temperature of the calibration fluids and the signal produced by the sensor.

Prerequisites

The temperature calibration is a two-part procedure: temperature offset calibration and temperature slope calibration. The two parts must be performed without interruption, in the order shown. Ensure that you are prepared to complete the process without interruption. You will need a low-temperature calibration fluid and a high-temperature calibration fluid. You will not see the effect of the calibration until both the temperature offset calibration and the temperature slope calibration are complete.

Important

Consult Micro Motion before performing a temperature calibration. Under normal circumstances, the temperature circuit is stable and should not need an adjustment.

- [Perform temperature calibration using the display](#) (Section 9.5.1)
- [Perform temperature calibration using ProLink III](#) (Section 9.5.2)
- [Perform temperature calibration using the Field Communicator](#) (Section 9.5.3)

9.5.1 Perform temperature calibration using the display

1. Read [Section 9.5](#) if you have not done so already.
2. Immerse the tines in a low-temperature fluid.
 - In a pipeline, bypass, or flow-through chamber installation, close an upstream valve and empty the segment. Then close a downstream valve, open the upstream valve, and fill the segment with the low-temperature fluid.
 - In a tank installation, empty the tank, then fill it with the low-temperature fluid.
3. Wait until the temperature of the tines matches the temperature of the fluid.
4. Navigate to the calibration menu and enter it.
 - a. Activate Scroll and Select simultaneously.
 - b. Scroll to OFF-LINE MAINT and activate Select.
 - c. Scroll to OFF-LINE CAL and activate Select.
 - d. Scroll to CAL TEMP and activate Select.
5. Enter the temperature of the low-temperature fluid.
 - a. When CAL OFFSET TEMP is flashing, activate Select.
 - b. Enter the temperature value and save it.
6. Immerse the tines in a high-temperature fluid.
7. Wait until the temperature of the tines matches the temperature of the fluid.
8. Enter the temperature of the high-temperature fluid.

- a. When CAL SLOPE TEMP is flashing, activate Select.
- b. Enter the temperature value and save it.
9. Activate Scroll to view the new offset and slope values.
10. Activate Select to exit.

9.5.2 Perform temperature calibration using ProLink III

1. Read [Section 9.5](#) if you have not done so already.
2. Immerse the tines in a low-temperature fluid.
 - In a pipeline, bypass, or flow-through chamber installation, close an upstream valve and empty the segment. Then close a downstream valve, open the upstream valve, and fill the segment with the low-temperature fluid.
 - In a tank installation, empty the tank, then fill it with the low-temperature fluid.
3. Wait until the temperature of the tines matches the temperature of the fluid.
4. Choose Device Tools > Calibration > Temperature > Temperature Offset.
5. Enter the temperature of the low-temperature fluid.
6. Click Start Calibration.
7. Immerse the tines in a high-temperature fluid.
8. Wait until the temperature of the tines matches the temperature of the fluid.
9. Choose Device Tools > Calibration > Temperature > Temperature Slope.
10. Enter the temperature of the high-temperature fluid.
11. Click Start Calibration.
12. To view the new offset and slope values, choose Device Tools > Configuration > Process Measurement > Line Temperature.

9.5.3 Perform temperature calibration using the Field Communicator

1. Read [Section 9.5](#) if you have not done so already.
2. Immerse the tines in a low-temperature fluid.
 - In a pipeline, bypass, or flow-through chamber installation, close an upstream valve and empty the segment. Then close a downstream valve, open the upstream valve, and fill the segment with the low-temperature fluid.
 - In a tank installation, empty the tank, then fill it with the low-temperature fluid.
3. Wait until the temperature of the tines matches the temperature of the fluid.
4. Choose Service Tools > Maintenance > Calibration > Temperature Calibration > Temperature Calibration Offset.
5. Enter the temperature of the low-temperature fluid.
6. Wait for the calibration to complete.
7. Immerse the tines in a high-temperature fluid.

8. Wait until the temperature of the tines matches the temperature of the fluid.
9. Choose Service Tools > Maintenance > Calibration > Temperature Calibration > Temperature Calibration Slope.
10. Enter the temperature of the high-temperature fluid.
11. Wait for the calibration to complete.

9.6 Adjust concentration measurement with Trim Offset

Trim Offset adjusts the meter's concentration measurement to match a reference value.

Tip

You can adjust concentration measurement by applying the trim offset only, or by applying both the trim offset and the trim slope. For most applications, the trim offset is sufficient.

Prerequisites

Ensure that the active matrix is the one that you want to trim. You can set the offset separately for each matrix on your transmitter.

You must be able to take a sample of your process fluid and obtain a laboratory concentration value at line density and line temperature.

Procedure

1. Take a concentration reading from the meter, and record line density and line temperature.
2. Take a sample of the process fluid and obtain a laboratory value for concentration at line density and line temperature, in the units used by the meter.
3. Subtract the meter value from the laboratory value.
4. Enter the result as the trim offset.
 - Using the display: Not available
 - Using ProLink III: Choose Device Tools > Configuration > Process Measurement > Concentration Measurement, set Matrix Being Configured to your matrix, and enter Trim Offset.
 - Using the Field Communicator: Configure > Manual Setup > Measurements > Conc Measure (CM) > Trim CM Process Variables > Concentration Offset
5. Take another concentration reading from the meter, and compare it to the laboratory value.
 - If the two values are acceptably close, the trim is complete.
 - If the two values are not acceptably close, repeat this procedure.

Example: Calculating the trim offset

Laboratory value	64.21 °Brix
Meter value	64.93 °Brix

$$64.21 - 64.93 = -0.72$$

Concentration offset: -0.72

Related information

[Adjust concentration measurement with Trim Slope and Trim Offset](#)

9.7 Adjust concentration measurement with Trim Slope and Trim Offset

Trim Slope and Trim Offset adjust the meter's concentration measurement to match a reference value.

Tip

You can adjust concentration measurement by applying the trim offset only, or by applying both the trim offset and the trim slope. For most applications, the trim offset is sufficient.

Prerequisites

- Ensure that the active matrix is the one that you want to trim. You can set the offset and slope separately for each matrix on your transmitter.
- You must be able to take measurements of your process fluid at two different concentrations.
- You must be able to take a sample of your process fluid at each of these concentrations.
- For each sample, you must be able to obtain a laboratory concentration value at line density and line temperature.

Procedure

1. Collect data for Comparison 1.
 - a. Take a concentration reading from the meter and record line density and line temperature.
 - b. Take a sample of the process fluid at the current concentration.
 - c. Obtain a laboratory value for concentration at line density and line temperature, in the units used by the meter.
2. Collect data for Comparison 2.
 - a. Change the concentration of your process fluid.

- b. Take a concentration reading from the meter and record line density and line temperature.
 - c. Take a sample of the process fluid at the current concentration.
 - d. Obtain a laboratory value for concentration at line density and line temperature, in the units used by the meter.
3. Populate the following equation with values from each comparison.

$$\text{Concentration}_{\text{Lab}} = (A \times \text{Concentration}_{\text{Meter}}) + B$$

4. Solve for A (slope).
5. Solve for B (offset), using the calculated slope and one set of values.
6. Enter the results as the trim slope and the trim offset.
 - Using the display: Not available
 - Using ProLink III: Choose Device Tools > Configuration > Process Measurement > Concentration Measurement, set Matrix Being Configured to your matrix, and enter Trim Slope and Trim Offset.
 - Using the Field Communicator: Configure > Manual Setup > Measurements > Conc Measure (CM) > Trim CM Process Variables
7. Take another concentration reading from the meter, and compare it to the laboratory value.
 - If the two values are acceptably close, the trim is complete.
 - If the two values are not acceptably close, repeat this procedure.

Example: Calculating the trim slope and the trim offset

Comparison 1	Laboratory value	50.00%
	Meter value	49.98%
Comparison 2	Laboratory value	16.00%
	Meter value	15.99%

Populate the equations:

$$50 = (A \times 49.98) + B$$

$$16 = (A \times 15.99) + B$$

Solve for A:

$$50.00 - 16.00 = 34.00$$

$$49.98 - 15.99 = 33.99$$

$$34 = A \times 33.99$$

$$A = 1.00029$$

Solve for B:

$$50.00 = (1.00029 \times 49.98) + B$$

$$50.00 = 49.99449 + B$$

$$B = 0.00551$$

Concentration slope (A): 1.00029

Concentration offset (B): 0.00551

Related information

[Adjust concentration measurement with Trim Offset](#)

9.8 Set up user-defined calculations

Display	Not available
ProLink III	Device Tools > Configuration > User-Defined Calculations
Field Communicator	Configure > Manual Setup > Measurements > User-Defined Calculations

Overview

User-defined calculations are used to enhance measurement or to adapt the meter to special process conditions.

A user-defined calculation allows you to create a new process variable by inserting constants and existing process variables into an equation. The output of the equation is the new process variable. Depending on your meter, either two or three equations are available.

Procedure

1. Select the user-defined calculation that you want to use.
2. If you selected User-Defined Calculation 1:
 - a. Enter the values to be used for the constants: A, B, X, Y.
 - b. Enter the values to be used for *a*, *b*, *c*, *d*, *e*, and *f*.

For these terms:

- You can specify a constant value.
- You can specify a process variable. If you choose this, the current value of the process variable is used in the calculation.

Important

User-defined calculations are performed using the meter's internal measurement units. Therefore:

- If a constant represents a process variable, you must enter its value in the internal measurement units.

- If a constant will be used to modify a process variable, you must use the internal measurement units to derive the constant.
-

3. If you selected User-Defined Calculation 2:

- a. Enter the values to be used for the constants: A, B, C.
- b. Enter the value to be used for t .

For this term:

- You can specify a constant value.
 - You can specify a process variable. If you choose this, the current value of the process variable is used in the calculation.
-

Important

User-defined calculations are performed using the meter's internal measurement units. Therefore:

- If a constant represents a process variable, you must enter its value in the internal measurement units.
 - If a constant will be used to modify a process variable, you must use the internal measurement units to derive the constant.
-

4. If you selected User-Defined Calculation 3:

- a. Enter the values to be used for the constants: A, B, C, E, F.
 - b. Enter the value to be used for ρ_W (the density of water at reference temperature and reference pressure)
-

Restriction

User-Defined Calculation 3 is available only if the concentration measurement application is enabled and a matrix is active.

Important

User-defined calculations are performed using the meter's internal measurement units. Therefore:

- If a constant represents a process variable, you must enter its value in the internal measurement units.
 - If a constant will be used to modify a process variable, you must use the internal measurement units to derive the constant.
-

5. Enter a label to be used for the output of the user-defined calculation (the new process variable).
6. (Optional) Set up a reporting method for the new process variable.

The new process variable can be configured as a display variable or a HART variable, or assigned to an mA output. It can also be read using digital communications.

Important

The output of the user-defined calculation is based on internal measurement units for process variables. You may need to convert this value to the configured units before using it in your application or process.

- [Equations used in user-defined calculations](#) (Section 9.8.1)
- [Measurement units used in user-defined calculations](#) (Section 9.8.2)

9.8.1 Equations used in user-defined calculations

Each user-defined calculation has an equation and a set of user-programmable constants and/or user-specified process variables.

Equation 9-1: User-defined calculation 1 (square root)

$$y = A + B \times \left(\frac{a \times (b + (X \times c))}{d \times (e + (Y \times \sqrt{f}))} \right)$$

A, B, X, Y	User-programmable constants
a, b, c, d, e, f	User-programmable constants or user-specified process variables
y	Result of calculation

Equation 9-2: User-defined calculation 2 (exponential)

$$y = e^{(A + (B \times t) + (C \times t^2))}$$

e	Natural logarithm
A, B, C	User-programmable constants
t	User-programmable constant or user-specified process variable
y	Result of calculation

Equation 9-3: User-defined calculation 3 (quartic)

$$y = A + B \times \left(\frac{\rho_B}{\rho_W} \right) + C \times \left(\frac{\rho_B}{\rho_W} \right)^2 + E \times \left(\frac{\rho_B}{\rho_W} \right)^3 + F \times \left(\frac{\rho_B}{\rho_W} \right)^4$$

A, B, C, E, F	User-programmable constants
ρ_W	Density of water at reference temperature and reference pressure, user-programmable
ρ_B	Referred density from the concentration measurement application
y	Result of calculation

9.8.2 Measurement units used in user-defined calculations

The meter's internal measurement units are used for all process variables referenced by a user-defined calculation. All constants must be entered in the internal measurement units or derived using the internal measurement units.

Table 9-1: Process variables and internal measurement units

Process variable	Internal measurement unit
Density	g/cm ³
Referred Density	g/cm ³
Mass Flow (external or calculated)	kg/sec
Volume Flow (external or calculated)	l/sec
Line Temperature	°C
External Temperature	°C
Board Temperature	°C
Drive Gain	%
Concentration	%
Line Pressure	Bar g
Sensor Time Period	Microseconds
Specific Gravity (concentration measurement)	Unitless

10 Troubleshooting

Topics covered in this chapter:

- *Quick guide to troubleshooting*
- *Check power supply wiring*
- *Check grounding*
- *Perform loop tests*
- *Status LED states*
- *Status alerts, causes, and recommendations*
- *Density measurement problems*
- *Temperature measurement problems*
- *API referral problems*
- *Concentration measurement problems*
- *Milliamp output problems*
- *Discrete output problems*
- *Time Period Signal (TPS) output problems*
- *Using sensor simulation for troubleshooting*
- *Trim mA outputs*
- *Check HART communications*
- *Check Lower Range Value and Upper Range Value*
- *Check mA Output Fault Action*
- *Check for radio frequency interference (RFI)*
- *Check the cutoffs*
- *Check for two-phase flow (slug flow)*
- *Check the drive gain*
- *Check for internal electrical problems*
- *Locate a device using the HART 7 Squawk feature*

10.1 Quick guide to troubleshooting

The meter may report or exhibit issues that are caused by installation problems, wiring problems, configuration problems, process problems, problems with external devices, or mechanical issues with the sensor itself.

To identify and resolve problems as effectively as possible, work through the following list of suggestions:

- If this is a first installation:
 - Verify the power wiring and power supply.

- Verify the output wiring. The outputs must be powered externally.
- Verify the grounding.
- Verify cable shielding.
- Perform loop tests for each output.
- Check the sensor installation and orientation. Ensure that it is appropriate for your application.
- Ensure that the installation meets temperature and/or pressure requirements.
- Check for active status alerts and follow the recommendations.
- If the device appears to be functioning correctly, but the process data is not acceptable, review the symptoms and suggestions in the following sections:
 - Density measurement problems (see [Section 10.7](#))
 - Temperature measurement problems (see [Section 10.8](#))
 - API referral problems (see [Section 10.9](#))
 - Concentration measurement problems (see [Section 10.10](#))
- If the device appears to be functioning correctly, but the control loop is not performing as expected:
 - Verify the output wiring.
 - Ensure that all external devices are operational, are receiving data, and are configured appropriately.
 - Use sensor simulation to test boundary conditions and system response.

10.2 Check power supply wiring

If the power supply wiring is damaged or improperly connected, the transmitter may not receive enough power to operate properly.

Prerequisites

You will need the installation manual for your transmitter.

Procedure

1. Use a voltmeter to test the voltage at the transmitter's power supply terminals.
 - If the voltage is within the specified range, you do not have a power supply problem.
 - If the voltage is low, ensure that the power supply is adequate at the source, the power cable is sized correctly, there is no damage to the power cable, and an appropriate fuse is installed.
 - If there is no power, continue with this procedure.
2. Before inspecting the power supply wiring, disconnect the power source.

⚠ CAUTION!

If the transmitter is in a hazardous area, wait five minutes after disconnecting the power.

3. Ensure that the terminals, wires, and wiring compartment are clean and dry.
4. Ensure that the power supply wires are connected to the correct terminals.
5. Ensure that the power supply wires are making good contact, and are not clamped to the wire insulation.
6. Reapply power to the transmitter.

⚠ CAUTION!

If the transmitter is in a hazardous area, do not reapply power to the transmitter with the housing cover removed. Reapplying power to the transmitter while the housing cover is removed could cause an explosion.

7. Test the voltage at the terminals.
If there is no power, contact Micro Motion customer service.

10.3 Check grounding

The sensor and the transmitter must be grounded.

Prerequisites

You will need:

- Installation manual for your sensor
- Installation manual for your transmitter (remote-mount installations only)

Procedure

Refer to the sensor and transmitter installation manuals for grounding requirements and instructions.

10.4 Perform loop tests

A loop test is a way to verify that the transmitter and the remote device are communicating properly. A loop test also helps you know whether you need to trim mA outputs.

- [Perform loop tests using the display](#) (Section 10.4.1)
- [Perform loop tests using ProLink III](#) (Section 10.4.2)
- [Perform loop tests using the Field Communicator](#) (Section 10.4.3)

10.4.1 Perform loop tests using the display

Prerequisites

Before performing a loop test, configure the channels for the transmitter inputs and outputs that will be used in your application.

Follow appropriate procedures to ensure that loop testing will not interfere with existing measurement and control loops.

Procedure

1. Test the mA outputs.
 - a. Choose OFFLINE MAINT > SIM > AO1 SIM or OFFLINE MAINT > SIM > AO2 SIM, and select a low value, e.g., 4 mA.

Dots traverse the display while the output is fixed.
 - b. Read the mA current at the receiving device and compare it to the transmitter output.

The readings do not need to match exactly. If the values are slightly different, you can correct the discrepancy by trimming the output.
 - c. At the transmitter, activate Select.
 - d. Scroll to and select a high value, e.g., 20 mA.

Dots traverse the display while the output is fixed.
 - e. Read the mA current at the receiving device and compare it to the transmitter output.

The readings do not need to match exactly. If the values are slightly different, you can correct the discrepancy by trimming the output.
 - f. At the transmitter, activate Select.
2. Test the discrete outputs.
 - a. Choose OFFLINE MAINT > SIM > DO SIM, and select SET ON.

Dots traverse the display while the output is fixed.
 - b. Verify the signal at the receiving device.
 - c. At the transmitter, activate Select.
 - d. Scroll to and select SET OFF.
 - e. Verify the signal at the receiving device.
 - f. At the transmitter, activate Select.
3. Test the TPS output.

- a. Attach a frequency counter, oscilloscope, digital multimeter (DMM), or digital voltmeter (DVM) to the TPS output loop.
- b. Compare the reading to the Sensor Time Period process variable at your meter.

Postrequisites

- If the mA output readings are within 200 microamps of each other, you can correct this discrepancy by trimming the output.
- If the discrepancy between the mA output readings is greater than 200 microamps, or if at any step the reading was faulty, verify the wiring between the transmitter and the remote device, and try again.
- If the discrete output readings are reversed, check the setting of Discrete Output Polarity.
- If the TPS output readings do not match, contact Micro Motion customer service.

10.4.2 Perform loop tests using ProLink III

Prerequisites

Before performing a loop test, configure the channels for the transmitter inputs and outputs that will be used in your application.

Follow appropriate procedures to ensure that loop testing will not interfere with existing measurement and control loops.

Procedure

1. Test the mA outputs.
 - a. Choose Device Tools > Diagnostics > Testing > mA Output 1 Test or Device Tools > Diagnostics > Testing > mA Output 2 Test.
 - b. Enter 4 in Fix to:.
 - c. Click Fix mA.
 - d. Read the mA current at the receiving device and compare it to the transmitter output.

The readings do not need to match exactly. If the values are slightly different, you can correct the discrepancy by trimming the output.
 - e. Click UnFix mA.
 - f. Enter 20 in Fix to:.
 - g. Click Fix mA.
 - h. Read the mA current at the receiving device and compare it to the transmitter output.

The readings do not need to match exactly. If the values are slightly different, you can correct the discrepancy by trimming the output.
 - i. Click UnFix mA.

2. Test the discrete outputs.
 - a. Choose Device Tools > Diagnostics > Testing > Discrete Output Test.
 - b. Set Fix To: to ON.
 - c. Verify the signal at the receiving device.
 - d. Set Fix To: to OFF.
 - e. Verify the signal at the receiving device.
 - f. Click UnFix.
3. Test the TPS output.
 - a. Attach a frequency counter, oscilloscope, digital multimeter (DMM), or digital voltmeter (DVM) to the TPS output loop.
 - b. Compare the reading to the Sensor Time Period process variable at your meter.

Postrequisites

- If the mA output readings are within 200 microamps of each other, you can correct this discrepancy by trimming the output.
- If the discrepancy between the mA output readings is greater than 200 microamps, or if at any step the reading was faulty, verify the wiring between the transmitter and the remote device, and try again.
- If the discrete output readings are reversed, check the setting of Discrete Output Polarity.
- If the TPS output readings do not match, contact Micro Motion customer service.

10.4.3 Perform loop tests using the Field Communicator

Prerequisites

Before performing a loop test, configure the channels for the transmitter inputs and outputs that will be used in your application.

Follow appropriate procedures to ensure that loop testing will not interfere with existing measurement and control loops.

Procedure

1. Test the mA outputs.
 - a. Choose Service Tools > Simulate > Simulate Outputs > mA Output 1 Loop Test or Service Tools > Maintenance > Simulate Outputs > mA Output 2 Loop Test, and select 4 mA.
 - b. Read the mA current at the receiving device and compare it to the transmitter output.

The readings do not need to match exactly. If the values are slightly different, you can correct the discrepancy by trimming the output.

- c. Press OK.
- d. Select 20 mA.

- e. Read the mA current at the receiving device and compare it to the transmitter output.
The readings do not need to match exactly. If the values are slightly different, you can correct the discrepancy by trimming the output.
 - f. Press OK.
 - g. Choose End.
2. Test the discrete outputs.
 - a. Press Service Tools > Simulate > Simulate Outputs > Discrete Output Loop Test.
 - b. Choose Off.
 - c. Verify the signal at the receiving device.
 - d. Press OK.
 - e. Choose On.
 - f. Verify the signal at the receiving device.
 - g. Press OK.
 - h. Choose End.
 3. Test the TPS output.
 - a. Attach a frequency counter, oscilloscope, digital multimeter (DMM), or digital voltmeter (DVM) to the TPS output loop.
 - b. Compare the reading to the Sensor Time Period process variable at your meter.

Postrequisites

- If the mA output readings are within 200 microamps of each other, you can correct this discrepancy by trimming the output.
- If the discrepancy between the mA output readings is greater than 200 microamps, or if at any step the reading was faulty, verify the wiring between the transmitter and the remote device, and try again.
- If the discrete output readings are reversed, check the setting of Discrete Output Polarity.
- If the TPS output readings do not match, contact Micro Motion customer service.

10.5 Status LED states

The status LED on the transmitter indicates whether or not alerts are active. If alerts are active, view the alert list to identify the alerts, then take appropriate action to correct the alert condition.

Your meter has one or two status LEDs:

- A status LED on the display (only if your meter has a display)
- A status LED on the board, beneath the meter housing cover

⚠ CAUTION!

If your meter is in a hazardous area, do not remove the meter housing cover. Use a different method to determine meter status.

The status LEDs use colors and flashing to indicate device status.

Table 10-1: Transmitter status reported by status LED

LED state	Description	Recommendation
Green	No alerts are active.	Continue with configuration or process measurement.
Yellow	One or more low-severity alerts are active.	A low-severity alert condition does not affect measurement accuracy or output behavior. You can continue with configuration or process measurement. If you choose, you can identify and resolve the alert condition.
Flashing yellow	Calibration in progress, or Known Density Verification in progress.	The low-severity alert condition does not affect measurement accuracy or output behavior. You can continue with configuration or process measurement. If you chose, you can identify and resolve the alert condition.
Red	One or more high-severity alerts are active.	A high-severity alert condition affects measurement accuracy and output behavior. Resolve the alert condition before continuing.

Related information

[View and acknowledge status alerts](#)

10.6 Status alerts, causes, and recommendations

Table 10-2: Status alerts, causes, and recommendations

Alert number	Alert title	Possible causes	Recommended actions
A001	EEPROM Error	The transmitter has detected a problem communicating with the sensor.	<ul style="list-style-type: none"> • Cycle power to the meter. • Contact Micro Motion.
A002	RAM Error	The transmitter has detected a problem communicating with the sensor.	<ul style="list-style-type: none"> • Cycle power to the meter. • Contact Micro Motion.
A003	No Sensor Response	The transmitter is not receiving one or more basic electrical signals from the sensor.	<ul style="list-style-type: none"> • Check the drive gain. See Section 10.22.

Table 10-2: Status alerts, causes, and recommendations (continued)

Alert number	Alert title	Possible causes	Recommended actions
A004	Temperature Overrange	The RTD resistance is out of range for the sensor.	<ul style="list-style-type: none"> • Check your process conditions against the values reported by the device. • Verify temperature characterization or calibration parameters. • Contact Micro Motion.
A006	Characterization Required	Calibration factors have not been entered, or the sensor type is incorrect, or the calibration factors are incorrect for the sensor type.	<ul style="list-style-type: none"> • Verify all of the characterization or calibration parameters. See the sensor tag or the calibration sheet for your meter. • Contact Micro Motion.
A008	Density Overrange	<p>Applies only to the active calibration.</p> <p>The line density is greater than 3 g/cm³ (3000 kg/m³).</p>	<ul style="list-style-type: none"> • If other alerts are present, resolve those alert conditions first. If the current alert persists, continue with the recommended actions. • Check for two-phase flow. See Section 10.21. • Check for foreign material in the process gas or fluid, coating, or other process problems. • Verify all of the characterization or calibration parameters. See the sensor tag or the calibration sheet for your meter. • Check the drive gain. See Section 10.22. • Perform Known Density Verification. • Check the tines for corrosion, erosion, or deposition. • Contact Micro Motion.
A009	Transmitter Initializing/Warming Up or Significant Process Instability	<p>Transmitter is in power-up mode.</p> <p>If this occurs after device startup, measurement stability has dropped below acceptable limits and the device is repeating its startup sequence.</p>	<ul style="list-style-type: none"> • Allow the meter to complete its power-up sequence. The alert should clear automatically. • If other alerts are present, resolve those alert conditions first. If the current alert persists, continue with the recommended actions. • Verify that the transmitter is receiving sufficient power. <ul style="list-style-type: none"> - If it is not, correct the problem and cycle power to the meter. - If it is, this suggests that the transmitter has an internal power issue. Replace the transmitter. • Ensure that the process fluid is stable. Check for two-phase flow, high process noise, or a fast transition between two fluids of different densities.
A010	Calibration Failure	<p>Many possible causes.</p> <p>This alert will not clear until you correct the problem, acknowledge the alert, and repeat the calibration.</p>	<ul style="list-style-type: none"> • Ensure that your calibration procedure meets the documented requirements, cycle power to the meter, then retry the procedure.

Table 10-2: Status alerts, causes, and recommendations (continued)

Alert number	Alert title	Possible causes	Recommended actions
A014	Transmitter Failure	Many possible causes.	<ul style="list-style-type: none"> • Ensure that all wiring compartment covers are installed correctly. • Ensure that all transmitter wiring meets specifications and that all cable shields are properly terminated. • Check the grounding of all components. See Section 10.3. • Evaluate the environment for sources of high electromagnetic interference (EMI) and relocate the transmitter or wiring as necessary. • Contact Micro Motion.
A016	Sensor Temperature (RTD) Failure	The value computed for the resistance of the line RTD is outside limits.	<ul style="list-style-type: none"> • Check your process against the values reported by the device. • Contact Micro Motion.
A020	Calibration Factors Missing	Some calibration factors have not been entered or are incorrect.	<ul style="list-style-type: none"> • Verify all of the characterization or calibration parameters. See the sensor tag or the calibration sheet for your meter. • Contact Micro Motion.
A021	Transmitter/Sensor/Software Mismatch	The configured board type does not match the physical board.	<ul style="list-style-type: none"> • Verify all of the characterization or calibration parameters. See the sensor tag or the calibration sheet for your meter. • Ensure that the correct board is installed.
A029	Internal Electronics Failure	This can indicate a loss of communication between the transmitter and the display module.	<ul style="list-style-type: none"> • Cycle power to the meter. • Replace the display module. • Contact Micro Motion.
A030	Incorrect Board Type	The loaded software is not compatible with the programmed board type.	<ul style="list-style-type: none"> • Contact Micro Motion.
A033	Insufficient Pickoff Signal	The signal from the sensor pickoff(s) is insufficient. This suggests that the sensor tubes or vibrating elements are not vibrating. This alert often occurs in conjunction with Alert 102.	<ul style="list-style-type: none"> • Check for foreign material in the process gas or fluid, coating, or other process problems. • Check for fluid separation by monitoring the density value and comparing the results against expected density values. • Ensure that the sensor orientation is appropriate for your application. Settling from a two-phase or three-phase fluid can cause this alert.
A037	Sensor Check Failed	Known Density Verification failed.	<ul style="list-style-type: none"> • Check the subtest results and perform the recommended actions. • Retry the test. • Contact Micro Motion.
A038	Time Period Signal Out of Range	The time period signal is outside the limits for the sensor type.	<ul style="list-style-type: none"> • Check your process conditions against the values reported by the device.

Table 10-2: Status alerts, causes, and recommendations (continued)

Alert number	Alert title	Possible causes	Recommended actions
A100	mA Output 1 Saturated	The calculated mA output value is outside the configured range.	<ul style="list-style-type: none"> Check the settings of Upper Range Value and Lower Range Value. See Section 10.17. Check process conditions. Actual conditions may be outside the normal conditions for which the output is configured. Check for foreign material in the process gas or fluid, coating, or other process problems. Verify that the measurement units are configured correctly for your application.
A101	mA Output 1 Fixed	The HART address is set to a non-zero value, or the mA output is configured to send a constant value.	<ul style="list-style-type: none"> Check whether the output is in loop test mode. If it is, unfix the output. Exit mA output trim, if applicable. Check the HART address. If the HART address is non-zero, you may need to change the setting of mA Output Action (Loop Current Mode). Check whether the output has been set to a constant value via digital communication.
A102	Drive Over-range	The drive power (current/voltage) is at its maximum.	<ul style="list-style-type: none"> Check the drive gain. See Section 10.22. Check for foreign material in the process gas or fluid, coating, or other process problems. Check for fluid separation by monitoring the density value and comparing the results against expected density values. Ensure that the sensor orientation is appropriate for your application. Settling from a two-phase or three-phase fluid can cause this alert.
A104	Calibration in Progress	A calibration procedure is in process.	<ul style="list-style-type: none"> Allow the procedure to complete.
A105	Two-Phase Flow	The line density is outside the user-defined two-phase flow limits.	<ul style="list-style-type: none"> Check for two-phase flow. See Section 10.21.
A106	Burst Mode Enabled	HART burst mode is enabled.	<ul style="list-style-type: none"> No action required. If desired, you can set Alert Severity Level to Ignore.
A107	Power Reset Occurred	The transmitter has been restarted.	<ul style="list-style-type: none"> No action required. If desired, you can set Alert Severity Level to Ignore.
A113	mA Output 2 Saturated	The calculated mA output value is outside the configured range.	<ul style="list-style-type: none"> Check the settings of Upper Range Value and Lower Range Value. See Section 10.17. Check process conditions. Actual conditions may be outside the normal conditions for which the output is configured. Check for foreign material in the process gas or fluid, coating, or other process problems. Verify that the measurement units are configured correctly for your application.

Table 10-2: Status alerts, causes, and recommendations (continued)

Alert number	Alert title	Possible causes	Recommended actions
A114	mA Output 2 Fixed	The mA output is configured to send a constant value.	<ul style="list-style-type: none"> • Check whether the output is in loop test mode. If it is, unfix the output. • Exit mA output trim, if applicable. • Check whether the output has been set to a constant value via digital communication.
A115	No External Input or Polled Data	The connection to an external measurement device has failed. No external data is available.	<ul style="list-style-type: none"> • Verify that the external device is operating correctly. • Verify the wiring between the transmitter and the external device. • Verify the HART polling configuration.
A116	Temperature Overrange (API Referral)	The measured temperature is outside the range of the API table.	<ul style="list-style-type: none"> • Check your process conditions against the values reported by the device. • Verify the configuration of the API referral application and related parameters. See Section 10.9.
A117	Density Overrange (API Referral)	The measured density is outside the range of the API table.	<ul style="list-style-type: none"> • Check your process conditions against the values reported by the device. • Verify the configuration of the API referral application and related parameters. See Section 10.9.
A118	Discrete Output 1 Fixed	The discrete output has been configured to send a constant value.	<ul style="list-style-type: none"> • Check whether the output is in loop test mode. If it is, unfix the output.
A120	Curve Fit Failure (Concentration)	The transmitter was unable to calculate a valid concentration matrix from the current data.	<ul style="list-style-type: none"> • Verify the configuration of the concentration measurement application.
A121	Extrapolation Alert (Concentration)	The line density or line temperature is outside the range of the concentration matrix plus the configured extrapolation limit.	<ul style="list-style-type: none"> • Check your process conditions against the values reported by the device. • Verify the configuration of the concentration measurement application.
A122	Pressure Overrange (API Referral)	The line pressure is outside the range of the API table.	<ul style="list-style-type: none"> • Check your process conditions against the values reported by the device. • Verify the configuration of the API referral application and related parameters. See Section 10.9.
A132	Sensor Simulation Active	Sensor simulation is enabled.	<ul style="list-style-type: none"> • Disable sensor simulation.
A133	EEPROM Error (Display)	There is a memory error in the display module.	<ul style="list-style-type: none"> • Cycle power to the meter. • Replace the display module. • Contact Micro Motion.
A136	Incorrect Display Type	An incorrect display module has been installed on the device. This may cause a safety violation in hazardous areas.	<ul style="list-style-type: none"> • Replace the installed display module with an appropriate display module.

10.7 Density measurement problems

Table 10-3: Density measurement problems and recommended actions

Problem	Possible causes	Recommended actions
Erratic density reading	<ul style="list-style-type: none"> • Normal process noise • Two-phase flow • Flow rate too high • Deposition on the tines • Contaminants or suspended solids in the process fluid • Vibration in the pipeline • Erosion or corrosion 	<ul style="list-style-type: none"> • Check your process conditions. • Increase the density damping value. • Reduce the flow rate. • Check for two-phase flow. See Section 10.21. • Ensure that line pressure or sample pressure meets installation requirements. • Increase back pressure to minimize bubble formation. • Clean the tines. • Minimize vibration in the pipeline. • Install a flow control method (bypass, flow chamber, expander, etc.). • Perform Known Density Verification. • Replace the FDM with the CDM. The FDM has an upper limit on suspended solids.
Inaccurate density reading	<ul style="list-style-type: none"> • Inaccurate temperature measurement • Incorrect calibration factors • Deposition on the tines • Contaminants or suspended solids in the process fluid • Boundary effect (incorrect installation) 	<ul style="list-style-type: none"> • Verify the temperature reading from the RTD (on-board temperature sensor). • Verify the temperature reading from the external temperature device, if applicable. • Verify or adjust the density offset and/or the density meter factor. • Clean the tines. • Increase the flow rate. • Install a thermal insulation jacket. • Verify the calibration factors. • Perform Known Density Verification. • Change the location of the fork.
Density reading too high	<ul style="list-style-type: none"> • Deposition on the tines • Inaccurate temperature measurement • Incorrect calibration factors 	<ul style="list-style-type: none"> • Clean the tines. • Verify the temperature reading from the RTD (on-board temperature sensor). • Verify the temperature reading from the external temperature device, if applicable.
Density reading too low	<ul style="list-style-type: none"> • Leaks in the pipework or fittings • Incorrect calibration factors • Inaccurate temperature measurement • Two-phase flow 	<ul style="list-style-type: none"> • Check for leakage. • Verify the calibration factors. • Verify the temperature reading from the RTD (on-board temperature sensor). • Verify the temperature reading from the external temperature device, if applicable. • Check for two-phase flow. See Section 10.21.

Table 10-3: Density measurement problems and recommended actions (continued)

Problem	Possible causes	Recommended actions
Cyclic inaccuracy in density reading	<ul style="list-style-type: none"> • Stirrer rotation rate too high • Tank flow rate too high • Fork in poor location • Stirrer creating bubbles • Solids in tank 	<ul style="list-style-type: none"> • Reduce the stirrer rotation rate. • Reduce the tank flow rate. • Move the fork to a location with a lower flow profile. • Install a sample bypass. • Replace the device with a CDM.
Density reading from device does not match laboratory value	<ul style="list-style-type: none"> • Incorrect calibration factors • Laboratory conditions do not match sample conditions 	<ul style="list-style-type: none"> • Verify the calibration factors. • Verify or adjust the density offset and/or the density meter factor. • Ensure that the two fluids are being compared at the same temperature.

10.8 Temperature measurement problems

Table 10-4: Temperature measurement problems and recommended actions

Problem	Possible causes	Recommended actions
Temperature reading significantly different from process temperature	<ul style="list-style-type: none"> • RTD failure • Incorrect compensation factors • Line temperature in bypass does not match temperature in main line 	<ul style="list-style-type: none"> • Verify that the temperature compensation factors match the value on the sensor tag or calibration sheet. • If Alert A004, A016, or A017 is active, perform the actions recommended for that alert.
Temperature reading slightly different from process temperature	<ul style="list-style-type: none"> • Sensor temperature not yet equalized • Sensor leaking heat 	<ul style="list-style-type: none"> • If the error is within the temperature specification for the sensor, there is no problem. If the temperature measurement is outside the specification, contact Micro Motion. • The temperature of the fluid may be changing rapidly. Allow sufficient time for the sensor to equalize with the process fluid. • Install thermal insulation, up to but not over, the transmitter housing. • The electrical connection between the RTD and the sensor may be damaged. This may require replacing the sensor.

Table 10-4: Temperature measurement problems and recommended actions (continued)

Problem	Possible causes	Recommended actions
Inaccurate temperature data from external device	<ul style="list-style-type: none"> • Wiring problem • Problem with input configuration • Problem with external device 	<ul style="list-style-type: none"> • Verify the wiring between the transmitter and the external device. • Verify that the external device is operating correctly. • Verify the configuration of the temperature input. • Ensure that both devices are using the same measurement unit.

10.9 API referral problems

Table 10-5: API referral problems and recommended actions

Problem	Possible causes	Recommended actions
No referred density reading	<ul style="list-style-type: none"> • Line pressure, line temperature, or line density is outside the range of the configured API table 	<ul style="list-style-type: none"> • Check process conditions. • Ensure that the API referral application is configured correctly for your process fluid. See Section 4.5.
Inaccurate referred density reading	<ul style="list-style-type: none"> • Inaccurate density measurement • Inaccurate temperature measurement • Incorrect reference conditions • Incorrect API table selection 	<ul style="list-style-type: none"> • Verify the line density value. If it is not accurate, resolve your density measurement problems. • Verify the line temperature value. If it is not accurate, resolve your temperature measurement problems. • Ensure that the application is configured to use the appropriate temperature source. • Ensure that reference temperature and reference pressure, if applicable, are configured correctly. • Ensure that the selected API table is appropriate for the process fluid.

10.10 Concentration measurement problems

Table 10-6: Concentration measurement problems and recommended actions

Problem	Possible causes	Recommended actions
Significantly incorrect concentration measurement after loading matrix	<ul style="list-style-type: none"> • The wrong temperature or density unit was configured when the matrix was loaded 	<ul style="list-style-type: none"> • Set the temperature and density units to the units used when the matrix was built, then reload the matrix. For custom matrices, contact Micro Motion.

Table 10-6: Concentration measurement problems and recommended actions (continued)

Problem	Possible causes	Recommended actions
Inaccurate concentration measurement reading	<ul style="list-style-type: none"> • Inaccurate density measurement • Inaccurate temperature measurement • Incorrect reference conditions • Incorrect matrix data • Inappropriate trim values 	<ul style="list-style-type: none"> • Verify the line density value. If it is not accurate, resolve your density measurement problems. • Verify the line temperature value. If it is not accurate, resolve your temperature measurement problems. • Ensure that the application is configured to use the appropriate temperature source. • Ensure that reference temperature is configured correctly. • Ensure that the appropriate matrix is active. • Ensure that the matrix is configured correctly. • Ensure that the matrix curve fit is good. • Adjust the extrapolation limits for the active matrix. • Adjust the concentration value by applying an offset. See Section 9.6.

Related information

Standard matrices for the concentration measurement application
Concentration measurement matrices available by order
Load a concentration matrix using ProLink III

10.11 Milliamp output problems

Table 10-7: Milliamp output problems and recommended actions

Problem	Possible causes	Recommended actions
No mA output	<ul style="list-style-type: none"> • Output not powered • Wiring problem • Circuit failure 	<ul style="list-style-type: none"> • Verify that the output loop is powered externally. • Check the power supply and power supply wiring. See Section 10.2. • Verify the output wiring. • Check the Fault Action settings. See Section 10.18. • Contact Micro Motion.

Table 10-7: Milliamp output problems and recommended actions (continued)

Problem	Possible causes	Recommended actions
Loop test failed	<ul style="list-style-type: none"> • Output not powered • Power supply problem • Wiring problem • Circuit failure 	<ul style="list-style-type: none"> • Verify that the output loop is powered externally. • Check the power supply and power supply wiring. See Section 10.2. • Verify the output wiring. • Check the Fault Action settings. See Section 10.18. • Contact Micro Motion.
mA output below 4 mA	<ul style="list-style-type: none"> • Open in wiring • Bad output circuit • Process condition below LRV • LRV and URV are not set correctly • Fault condition if Fault Action is set to Internal Zero or Downscale • Bad mA receiving device 	<ul style="list-style-type: none"> • Check your process conditions against the values reported by the device. • Verify the receiving device, and the wiring between the transmitter and the receiving device. • Check the settings of Upper Range Value and Lower Range Value. See Section 10.17. • Check the Fault Action settings. See Section 10.18.
Constant mA output	<ul style="list-style-type: none"> • Incorrect process variable assigned to the output • Fault condition exists • Non-zero HART address (mA Output 1) • Output is configured for loop test mode 	<ul style="list-style-type: none"> • Verify the output variable assignments. • View and resolve any existing alert conditions. • Check the HART address. If the HART address is non-zero, you may need to change the setting of mA Output Action (Loop Current Mode). • Check to see if a loop test is in process (the output is fixed). • Check HART burst mode configuration.
mA output below 3.6 mA or above 21.0 ma	<ul style="list-style-type: none"> • Incorrect process variable or units assigned to output • Fault condition if Fault Action is set to Upscale or Downscale • LRV and URV are not set correctly 	<ul style="list-style-type: none"> • Verify the output variable assignments. • Verify the measurement units configured for the output. • Check the Fault Action settings. See Section 10.18. • Check the settings of Upper Range Value and Lower Range Value. See Section 10.17. • Check the mA output trim. See Section 10.15.
Consistently incorrect mA measurement	<ul style="list-style-type: none"> • Loop problem • Output not trimmed correctly • Incorrect measurement unit configured for process variable • Incorrect process variable configured • LRV and URV are not set correctly 	<ul style="list-style-type: none"> • Check the mA output trim. See Section 10.15. • Verify that the measurement units are configured correctly for your application. • Verify the process variable assigned to the mA output. • Check the settings of Upper Range Value and Lower Range Value. See Section 10.17.

Table 10-7: Milliamp output problems and recommended actions (continued)

Problem	Possible causes	Recommended actions
mA output correct at lower current, but incorrect at higher current	<ul style="list-style-type: none"> mA loop resistance may be set too high 	<ul style="list-style-type: none"> Verify that the mA output load resistance is below the maximum supported load (see the installation manual for your transmitter).

10.12 Discrete output problems

Table 10-8: Discrete output problems and recommended actions

Problem	Possible causes	Recommended actions
No discrete output	<ul style="list-style-type: none"> Output not powered Wiring problem Circuit failure 	<ul style="list-style-type: none"> Verify that the output loop is powered externally. Check the power supply and power supply wiring. See Section 10.2. Verify the output wiring. Contact Micro Motion.
Loop test failed	<ul style="list-style-type: none"> Output not powered Power supply problem Wiring problem Circuit failure 	<ul style="list-style-type: none"> Verify that the output loop is powered externally. Check the power supply and power supply wiring. See Section 10.2. Verify the output wiring. Contact Micro Motion.
Discrete output readings reversed	<ul style="list-style-type: none"> Wiring problem Configuration does not match wiring 	<ul style="list-style-type: none"> Verify the output wiring. Ensure that Discrete Output Polarity is set correctly.

10.13 Time Period Signal (TPS) output problems

Table 10-9: TPS output problems and recommended actions

Problem	Possible causes	Recommended actions
No TPS output	<ul style="list-style-type: none"> The TPS output is not supported on this device TPS wiring is connected to the wrong terminals Output not powered External short or low input impedance 	<ul style="list-style-type: none"> Verify that the output loop is powered externally. Check the power supply and power supply wiring. See Section 10.2. Verify the output wiring. Contact Micro Motion.

Table 10-9: TPS output problems and recommended actions (continued)

Problem	Possible causes	Recommended actions
Loop test failed	<ul style="list-style-type: none"> • Power supply problem • Wiring problem • Circuit failure 	<ul style="list-style-type: none"> • Verify that the output loop is powered externally. • Check the power supply and power supply wiring. See Section 10.2. • Verify the output wiring. • Contact Micro Motion.

10.14 Using sensor simulation for troubleshooting

When sensor simulation is enabled, the transmitter reports user-specified values for basic process variables. This allows you to reproduce various process conditions or to test the system.

You can use sensor simulation to help distinguish between legitimate process noise and externally caused variation. For example, consider a receiving device that reports an unexpectedly erratic density value. If sensor simulation is enabled and the observed density value does not match the simulated value, the source of the problem is probably somewhere between the transmitter and the receiving device.

Important

When sensor simulation is active, the simulated value is used in all transmitter outputs and calculations. Disable all automatic functions related to the transmitter outputs and place the loop in manual operation. Do not enable simulation mode unless your application can tolerate these effects, and be sure to disable simulation mode when you have finished testing.

Related information

[Test or tune the system using sensor simulation](#)

10.15 Trim mA outputs

Trimming an mA output calibrates the transmitter's mA output to the receiving device. If the current trim values are inaccurate, the transmitter will under-compensate or over-compensate the output.

- [Trim mA outputs using ProLink III](#) (Section 10.15.1)
- [Trim mA outputs using the Field Communicator](#) (Section 10.15.2)

10.15.1 Trim mA outputs using ProLink III

Trimming the mA output establishes a common measurement range between the transmitter and the device that receives the mA output.

Important

You must trim the output at both ends (4 mA and 20 mA) to ensure that it is compensated accurately across the entire output range.

Prerequisites

Ensure that the mA output is wired to the receiving device that will be used in production.

Procedure

1. Choose Device Tools > Calibration > MA Output Trim > mA Output 1 Trim or Device Tools > Calibration > MA Output Trim > mA Output 2 Trim.
2. Follow the instructions in the guided method.

Important

If you are using a HART/Bell 202 connection, the HART signal over the primary mA output affects the mA reading. Disconnect the wiring between ProLink III and the transmitter terminals when reading the primary mA output at the receiving device. Reconnect to continue the trim.

3. Check the trim results. If any trim result is less than -200 microamps or greater than +200 microamps, contact Micro Motion customer service.

10.15.2 Trim mA outputs using the Field Communicator

Trimming the mA output establishes a common measurement range between the transmitter and the device that receives the mA output.

Important

You must trim the output at both ends (4 mA and 20 mA) to ensure that it is compensated accurately across the entire output range.

Prerequisites

Ensure that the mA output is wired to the receiving device that will be used in production.

Procedure

1. Choose Service Tools > Maintenance > Routine Maintenance > Trim mA Output 1 or Service Tools > Maintenance > Routine Maintenance > Trim mA Output 2.
2. Follow the instructions in the guided method.

Important

The HART signal over the primary mA output affects the mA reading. Disconnect the wiring between the Field Communicator and the transmitter terminals when reading the primary mA output at the receiving device. Reconnect to continue the trim.

3. Check the trim results. If any trim result is less than -200 microamps or greater than +200 microamps, contact Micro Motion customer service.

10.16 Check HART communications

If you cannot establish or maintain HART communications, or if the primary mA output is producing a fixed value, you may have a wiring problem or a HART configuration problem.

Prerequisites

You may need one or more of the following:

- The installation manual for your meter
- A Field Communicator
- A voltmeter
- Optional: The *HART Application Guide*, available at www.hartcomm.org

Procedure

1. Verify the HART address.

Tip

The default HART address is 0. This is the recommended value unless the device is in a multidrop network.

2. If the primary mA output is producing a fixed value of 4 mA, ensure that mA Output Action (Loop Current Mode) is enabled.

For all HART addresses except 0, mA Output Action must be enabled to allow the primary mA output to report process data.
3. Refer to the wiring diagrams in the installation manual and verify that the primary mA output is correctly wired for HART support.
4. Ensure that the output is powered.
5. Check for electrical problems at the transmitter terminals.
 - a. Disconnect the primary mA output wires from the transmitter's MAO1 terminals.
 - b. Wire and power the MAO1 terminals as shown in the following figure.

Figure 10-1: Wiring and power to test terminals

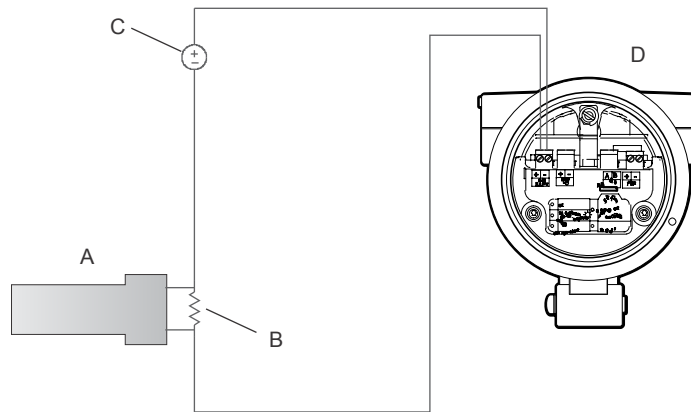

- A. Voltmeter
- B. 250–600 Ω resistance
- C. External power supply
- D. Transmitter with end-cap removed

- c. Using a voltmeter, check the voltage drop across the resistor.

For a 250 Ω resistor, 4–20 mA = 1–5 VDC. If the voltage drop is less than 1 VDC, add resistance to achieve a voltage drop within the required range.

- d. Connect a Field Communicator directly across the resistor and attempt to communicate (poll).

If this test fails, the transmitter may need service. Contact Micro Motion.

Related information

- [Configure basic HART parameters](#)
- [Using the Field Communicator with the transmitter](#)

10.17 Check Lower Range Value and Upper Range Value

If the process variable assigned to the mA output falls below the configured Lower Range Value (LRV) or rises above the configured Upper Range Value (URV), the meter will post a saturation alert (A100 or A113), then perform the configured fault action.

1. Record your current process conditions.
2. Check the configuration of the LRV and URV.

Related information

- [Configure Lower Range Value \(LRV\) and Upper Range Value \(URV\)](#)

10.18 Check mA Output Fault Action

mA Output Fault Action controls the behavior of the mA output if the transmitter encounters an internal fault condition. If the mA output is reporting a constant value below 4 mA or above 20 mA, the transmitter may be in a fault condition.

1. Check the status alerts for active fault conditions.
2. If there are active fault conditions, the transmitter is performing correctly. If you want to change its behavior, consider the following options:
 - Change the setting of mA Output Fault Action.
 - For the relevant status alerts, change the setting of Alert Severity to Ignore.

Restriction

For some status alerts, Alert Severity is not configurable.

3. If there are no active fault conditions, continue troubleshooting.

Related information

[Configure mA Output Fault Action and mA Output Fault Level](#)

10.19 Check for radio frequency interference (RFI)

The meter's TPS output or discrete output can be affected by radio frequency interference (RFI). Possible sources of RFI include a source of radio emissions, or a large transformer, pump, or motor that can generate a strong electromagnetic field. Several methods to reduce RFI are available. Use one or more of the following suggestions, as appropriate to your installation.

Procedure

- Use shielded cable between the output and the receiving device.
 - Terminate the shielding at the receiving device. If this is impossible, terminate the shielding at the cable gland or conduit fitting.
 - Do not terminate the shielding inside the wiring compartment.
 - 360-degree termination of shielding is unnecessary.
- Eliminate the RFI source.
- Move the meter.

10.20 Check the cutoffs

If the density cutoff is configured incorrectly for your process, any density process variables and any calculations that rely on density may be based on programmed cutoff values rather than current density data.

Procedure

Verify the configuration of all cutoffs.

Related information

[Configure Density Cutoff](#)

10.21 Check for two-phase flow (slug flow)

Two-phase flow can cause rapid changes in the drive gain. This can cause a variety of measurement issues.

1. Check for two-phase flow alerts (e.g., A105).
If the transmitter is not generating two-phase flow alerts, two-phase flow is not the source of your problem.
2. Check the process for cavitation, flashing, or leaks.
3. Monitor the density of your process fluid output under normal process conditions.
4. Check the settings of Two-Phase Flow Low Limit, Two-Phase Flow High Limit, and Two-Phase Flow Timeout.

Tip

You can reduce the occurrence of two-phase flow alerts by setting Two-Phase Flow Low Limit to a lower value, Two-Phase Flow High Limit to a higher value, or Two-Phase Flow Timeout to a higher value.

Related information

[Configure two-phase flow parameters](#)

10.22 Check the drive gain

Use the following table to check drive gain values. If you see a value that is too high or too low, there could be a problem with the process or with the device. Consider other diagnostics along with drive gain values to determine whether or not you have a problem.

Table 10-10: Abnormal drive gain, possible causes, and recommended actions

Drive gain value	Possible causes	Recommended actions
0%	<ul style="list-style-type: none"> • The transmitter is not connected to the sensor. • The connection between the transmitter and the sensor is damaged. 	<ul style="list-style-type: none"> • For integral installations, inspect the connection between the transmitter and the sensor and check for visible problems. • Contact Micro Motion customer service.

Table 10-10: Abnormal drive gain, possible causes, and recommended actions
(continued)

Drive gain value	Possible causes	Recommended actions
8%	Normal operation	No action required.
100%	The transmitter is unable to drive the sensor. Possible reasons: <ul style="list-style-type: none"> • Process viscosity is too high. • Vibration is too high. • Flow rate is too high. • The installation is incorrect. 	<ul style="list-style-type: none"> • Ensure that line viscosity is within sensor limits. • Ensure that vibration is within sensor limits. • Ensure that the flow rate is within sensor limits. • Review your installation to ensure that you are complying with all requirements and that you have implemented best practices where possible. • Contact Micro Motion customer service.

10.22.1 Collect drive gain data

Drive gain data can be used to diagnose a variety of process and equipment conditions. Collect drive gain data from a period of normal operation, and use this data as a baseline for troubleshooting.

1. Navigate to the drive gain data.
2. Observe and record drive gain data over an appropriate period of time, under a variety of process conditions.

10.23 Check for internal electrical problems

Shorts between sensor terminals or between the sensor terminals and the sensor case can cause the sensor to stop working.

Table 10-11: Possible causes and recommended actions for electrical shorts

Possible cause	Recommended action
Shorts to the housing created by trapped or damaged wires	Contact Micro Motion.
Loose wires or connectors	Contact Micro Motion.
Liquid or moisture inside the housing	Contact Micro Motion.

10.24 Locate a device using the HART 7 Squawk feature

The Squawk feature causes the device to show a specific pattern on its display. You can use this to locate or identify a device.

Restriction

The Squawk feature is available only with HART 7 connections. It is not available with ProLink III.

Procedure

1. Choose Service Tools > Maintenance.
2. Click Locate Device, then click Next.

An 0-0-0-0 pattern is shown on the display.

To return to the normal display, activate either Scroll or Select, or wait 60 seconds.

Appendix A

Calibration certificate

A.1 **Sample calibration certificate**

Your meter was shipped with a calibration certificate. The calibration certificate describes the calibrations and configurations that were performed or applied at the factory.

Figure A-1: Sample calibration certificate

	CALIBRATION CERTIFICATE
---	--------------------------------

FDM FORK DENSITY METER
FDM11A722AAC3V98EZZZ

SERIAL NO : 14110400
CAL DATE : 08-May-2013
PRESSURE TEST : 149 Bar

DENSITY CALIBRATION COEFFICIENTS @ 20°C (Free Stream) :

K0 = -2.408358E+03
K1 = -2.215938E-02
K2 = 1.771718E-03

DENSITY, $D = K0 + K1*TP + K2*TP^2$

CALIBRATION RANGE = 600-1250 kg/m³

TEMPERATURE COMPENSATION DATA :

K18 = -4.523227E-04
K19 = -1.046071E+00

$Dt = D(1 + K18(t-20)) + K19(t-20)$

SAMPLE

DENSITY CALIBRATION DATA :

DENSITY (kg/m ³)	TIME PERIOD, TP (μs)
1.2 (AIR)	1172.110
804.7	1352.786
998.4	1392.724

KNOWN DENSITY VERIFICATION DATA

VERIFICATION TIME PERIOD @ 20°C = 1171.854 μs

DENSITY CALIBRATION OVERCHECK

CALC DENSITY (kg/m ³)	ERROR (kg/m ³)
997.3	-1.0

where
D = Density (uncompensated)
Dt = Density (temperature compensated)
TP = Time period (μs)
t = Temperature (°C)

Reference FC V3.0.0.0

FINAL TEST & INSPECTION PASSED

Date 09-May-2013

All equipment used for this calibration is calibrated at routine intervals against standards that are traceable to National Standards of Measurement.

Appendix B

Using the transmitter display

Topics covered in this appendix:

- *Components of the transmitter interface*
- *Use the optical switches*
- *Access and use the display menu system*
- *Display codes for process variables*
- *Codes and abbreviations used in display menus*

B.1 Components of the transmitter interface

The transmitter interface includes the status LED, the display (LCD panel), and two optical switches.

B.2 Use the optical switches

Use the optical switches on the transmitter interface to control the transmitter display. The transmitter has two optical switches: Scroll and Select.

To activate an optical switch, block the light by holding your thumb or finger in front of the opening.

Tip

You can activate the optical switch through the lens. Do not remove the transmitter housing cover.

The optical switch indicator lights up when the transmitter senses that an optical switch has been activated.

Table B-1: Optical switch indicator and optical switch states

Optical switch indicator	State of optical switches
Solid red	One optical switch is activated.
Flashing red	Both optical switches are activated.

B.3 Access and use the display menu system

The display menu system is used to perform various configuration, administrative, and maintenance tasks.

Tip

The display menu system does not provide complete configuration, administrative, or maintenance functions. For complete transmitter management, you must use another communications tool.

Prerequisites

To access the display menu system, operator access to either the Off-Line menu or the Alert menu must be enabled. To access the complete menu system, operator access must be enabled for both the Off-Line menu and the Alert menu.

Procedure

1. At the transmitter display, activate the Scroll and Select optical switches simultaneously until the display changes.

You will enter the Off-Line menu at any of several locations, depending on several factors.

- If an alert is active and access to the Alert menu is enabled, you will see SEE ALARM.
- If no alert is active, you will see OFF-LINE MAINT.

2. If CODE? appears on the display when you make a choice, enter the value that is configured for Off-Line Password.
 - a. With the cursor flashing on the first digit, activate Scroll until the correct digit is displayed, then activate Select.
 - b. Repeat this process for the second, third, and fourth digits.

Tip

If you do not know the correct value for Off-Line Password, wait 30 seconds. The password screen will time out automatically and you will be returned to the previous screen.

3. Use the Scroll and Select optical switches to navigate to your destination in the display menu system.
 - Use Scroll to move through a list of options.
 - Use Select to choose the current option.
4. If Scroll flashes on the display, activate the Scroll optical switch, then the Select optical switch, and then the Scroll optical switch again.

The display will prompt you through this sequence. The Scroll-Select-Scroll sequence is designed to guard against accidental activation of the off-line menu. It is not designed as a security measure.
5. To exit a display menu and return to a higher-level menu:

- Activate Scroll until the EXIT option is displayed, then activate Select.
 - If the EXIT option is not available, activate Scroll and Select simultaneously and hold until the screen returns to the previous display.
6. To exit the display menu system, you can use either of the following methods:
- Exit each menu separately, working your way back to the top of the menu system.
 - Wait until the display times out and returns to displaying process variable data.

B.3.1 Enter a floating-point value using the display

Certain configuration values (for example, Lower Range Value and Upper Range Value) are entered as floating-point values. The display supports both decimal notation and exponential notation for floating-point values.

The display allows you to enter a maximum of 8 characters, including the sign. The decimal point is not counted as a character. Exponential notation is used to enter values that require more than 8 characters.

Enter a floating-point value using decimal notation

Decimal notation allows you to enter values between -9999999 and 99999999. You can use the decimal point to enter values with a precision of 0 through 4 (4 characters to the right of the decimal point).

Decimal values entered via the display must meet the following requirements:

- They can contain a maximum of 8 digits, or 7 digits plus a minus sign (-) to indicate a negative number.
- They can contain a decimal point. The decimal point does not count as a digit. The decimal point must be positioned so that the precision of the value does not exceed 4.

When you first enter the configuration screen, the current configuration value is displayed in decimal notation, and the active character is flashing. If the value is positive, no sign is displayed. If the value is negative, a minus sign is displayed.

Procedure

- To change the value:
 1. Activate Select until the digit you want to change is active (flashing).
Select moves the cursor one position to the left. From the leftmost position, Select moves the cursor to the rightmost digit.
 2. Activate Scroll to change the value of the active digit.
 3. Repeat until all digits are set as desired.
- To change the sign of the value:
 - If the current value is negative, activate Select until the minus sign is flashing, then activate Scroll until the space is blank.

- If the current value is positive and there is a blank space at the left of the value, activate Select until the cursor is flashing under the blank space, then activate Scroll until the minus sign appears.
- If the current value is positive and there is no blank space at the left of the value, activate Select until the cursor is flashing under the leftmost digit, then activate Scroll until the minus sign appears.
- To move the decimal point:
 1. Activate Select until the decimal point is flashing.
 2. Activate Scroll.

The decimal point is removed from its current position.

3. Activate Select and watch the position of the decimal point.

As the cursor moves to the left, the decimal point will flash between each pair of digits, up to a maximum precision of four (four digits to the right of the decimal point).

Tip

If the position is not valid, the decimal point is not displayed. Continue to activate Select until the decimal point appears at the right of the displayed value.

4. When the decimal point is in the desired position, activate Scroll.

The decimal point is inserted at its current position.

- To save the displayed value to transmitter memory, activate Scroll and Select simultaneously and hold until the display changes.
 - If the displayed value is the same as the value in transmitter memory, you will be returned to the previous screen.
 - If the displayed value is not the same as the value in transmitter memory, SAVE/YES? flashes on the display. Activate Select.
- To exit the menu without saving the displayed value to transmitter memory, activate Scroll and Select simultaneously and hold until the display changes.
 - If the displayed value is the same as the value in transmitter memory, you will be returned to the previous screen.
 - If the displayed value is not the same as the value in transmitter memory, SAVE/YES? flashes on the display. Activate Scroll.

Enter a floating-point value using exponential notation

Exponential notation is used to enter values that are larger than 99999999 or smaller than -99999999.

Exponential values entered via the display must be in the following form: SX.XXXEYY. In this string:

- S = Sign. A minus sign (-) indicates a negative number. A blank indicates a positive number.
- X.XXX = The 4-digit mantissa.
- E = The exponent indicator.
- YY = The 2-digit exponent.

Procedure

1. Switch from decimal notation to exponential notation.
 - a. Activate Select as required until the rightmost digit is flashing.
 - b. Activate Scroll until E is displayed.
 - c. Activate Select.

Tip

If you have modified the value in decimal notation without saving the changes to transmitter memory, the changes will be lost when you switch to exponential notation. Save the decimal value before switching to exponential notation.

2. Enter the exponent.

The first character may be a minus sign or any digit between 0 and 3. The second character may be any digit between 0 and 9.

 - a. Activate Select to move the cursor to the rightmost character on the display.
 - b. Activate Scroll until the desired character is displayed.
 - c. Activate Select to move the cursor one position to the left.
 - d. Activate Scroll until the desired character is displayed.
3. Enter the mantissa.

The mantissa must be a 4-digit value with a precision of 3 (that is, all values between 0.000 and 9.999).

 - a. Activate Select to move the cursor to the rightmost digit in the mantissa.
 - b. Activate Scroll until the desired character is displayed.
 - c. Activate Select to move the cursor one digit to the left.
 - d. Activate Scroll until the desired character is displayed.
 - e. Activate Select to move the cursor one digit to the left.
 - f. Activate Scroll until the desired character is displayed.
 - g. Activate Select to move the cursor one digit to the left.
 - h. Activate Scroll until the desired character is displayed.
4. Enter the sign.
 - a. Activate Select to move the cursor one digit to the left.
 - b. Activate Scroll until the desired character is displayed.

For positive numbers, select a blank space.

5. To save the displayed value to transmitter memory, activate Scroll and Select simultaneously and hold until the display changes.
 - If the displayed value is the same as the value in transmitter memory, you will be returned to the previous screen.
 - If the displayed value is not the same as the value in transmitter memory, SAVE/YES? flashes on the display. Activate Select.
6. Switch back from exponential notation to decimal notation.
 - a. Activate Select until the E is flashing.
 - b. Activate Select until d is displayed.
 - c. Activate Select.

B.4 Display codes for process variables

Table B-2: Display codes for process variables

Code	Definition
Standard	
DENS	Line Density
TEMP	Line Temperature
EXT T	Line Temperature (External)
EXT P	Line Pressure (External)
DGAIN	Drive Gain
TP B	Sensor Time Period
UCALC	User-Defined Calculation Output
MAG V	Volume Flow Rate (External)
MAG M	Mass Flow Rate (Calculated)
API referral	
RDENS	Referred Density (API)
Concentration measurement	
SG	Specific Gravity
CONC	Concentration
NET M	Net Mass Flow Rate
NET V	Net Volume Flow Rate

B.5 Codes and abbreviations used in display menus

Table B-3: Display codes for measurement units

Code	Measurement unit
%	Percent
%PLATO	°Plato
%SOL-V	% solution by volume
%SOL-W	% solution by weight
°C	°Celsius
°F	°Fahrenheit
°K	°Kelvin
°R	°Rankine
ATM	Atmospheres
B BBL	Beer barrels
BALL	°Balling
BAR	Bars
BAUMH	°Baumé heavy
BAUML	°Baumé light
BBBL/D	Beer barrels per day
BBBL/H	Beer barrels per hour
BBBL/M	Beer barrels per minute
BBBL/S	Beer barrels per second
BBL	Barrels
BBL/D	Barrels per day
BBL/H	Barrels per hour
BBL/MN	Barrels per minute
BBL/S	Barrels per second
BTU/D	British Thermal Units per day
BTU/H	British Thermal Units per hour
BTU/lb	British Thermal Units per pound
BTU/MN	British Thermal Units per minute
BTU/scf	British Thermal Units per standard cubic foot
CM	Centimeters
CMHG0	Centimeters of mercury at 4 °C
CMW60	Centimeters of water at 60 °F
cP	Centipoise
cSt	Centistoke
CUF/LB	Cubic feet per pound
CUF/MN	Cubic feet per minute
CUFT	Cubic feet

Table B-3: Display codes for measurement units (continued)

Code	Measurement unit
CUFT/D	Cubic feet per day
CUFT/H	Cubic feet per hour
CUFT/S	Cubic feet per second
CUIN	Cubic inches
CUYD	Cubic yards
D API	°API
DAY	Days
DBRIX	°Brix
DTWAD	°Twaddle
FT	Feet
FT/S	Feet per second
FTH2O	Feet H2O @ 68 °F
FTW4C	Feet of water at 4 °C
FTW60	Feet of water at 60 °F
G	Grams
G/CM3	Grams per cubic centimeter
G/H	Grams per hour
G/L	Grams per liter
G/MIN	Grams per minute
G/mL	Grams per milliliter
G/MOL	Grams per mole
G/S	Grams per second
G/SCM	Grams per square centimeter
HL	Hectoliters
HOUR	Hours
HPA	Hectopascals
HZ	Hertz
IN	Inches
INH2O	Inches of water at 68 °F
INHG	Inches of mercury at 0 °C
INW4C	Inches of water at 4 °C
INW60	Inches of water at 60 °F
KG	Kilograms
KG/D	Kilograms per day
KG/H	Kilograms per hour
KG/L	Kilograms per liter

Table B-3: Display codes for measurement units (continued)

Code	Measurement unit
KG/M2	Kilograms per square meter
KG/M3	Kilograms per cubic meter
KG/MIN	Kilograms per minute
KG/S	Kilograms per second
KG/SCM	Kilograms per square centimeter
KPA	Kilopascals
L	Liters
L/H	Liters per hour
L/MIN	Liters per minute
L/S	Liters per second
LB	Pounds
LB/CUF	Pounds per cubic foot
LB/CUI	Pounds per cubic inch
LB/D	Pounds per day
LB/GAL	Pounds per gallon
LB/H	Pounds per hour
LB/MIN	Pounds per minute
LB/S	Pounds per second
LT/D	Long tons per day
LT/H	Long tons per hour
M/H	Meters per hour
M/S	Meters per second
M3	Cubic meters
M3/D	Cubic meters per day
M3/H	Cubic meters per hour
M3/MIN	Cubic meters per minute
M3/S	Cubic meters per second
mA	Milliamperes
mBAR	Millibars
METER	Meters
MHG0C	Meters of mercury at 0 °C
MILG/D	Million gallons per day
MILL/D	Million liters per day
MIN	Minutes
MJ/DAY	Megajoules per day
MJ/H	Megajoules per hour

Table B-3: Display codes for measurement units (continued)

Code	Measurement unit
MJ/kg	Megajoules per kilogram
MJ/m ³	Megajoules per cubic meter
MJ/MIN	Megajoules per minute
mm	Millimeters
mmH ₂ O	Millimeters of water at 68 °F
mmHG	Millimeters of mercury at 0 °C
mmW ₄ C	Millimeters of water at 4 °C
MPA	Megapascals
mV	Millivolts
MW ₄ C	Meters of water at 4 °C
NL	Normal liters
NL/D	Normal liters per day
NL/H	Normal liters per hour
NL/MIN	Normal liters per minute
NL/S	Normal liters per second
NM ³	Normal cubic meters
NM ³ /D	Normal cubic meters per day
NM ³ /H	Normal cubic meters per hour
NM ³ /M	Normal cubic meters per minute
NM ³ /S	Normal cubic meters per second
OHM	Ohms
OUNCE	Ounce
PA	Pascals
PF	Picofarads
PPM	Parts per million
PRF/M	Proof per mass
PRF/V	Proof per volume
PSF	Pounds per square foot
PSI	Pounds per square inch gauge
PSI A	Pounds per square inch absolute
SCF	Standard cubic feet
SCFD	Standard cubic feet per day
SCFH	Standard cubic feet per hour
SCFM	Standard cubic feet per minute
SCFS	Standard cubic feet per second
SEC	Seconds

Table B-3: Display codes for measurement units (continued)

Code	Measurement unit
SGU	Specific gravity units
SL	Standard liter
SL/D	Standard liters per day
SL/H	Standard liters per hour
SL/MIN	Standard liters per minute
SL/S	Standard liters per second
SM3	Standard cubic meter
SM3/D	Standard cubic meters per day
SM3/H	Standard cubic meters per hour
SM3/M	Standard cubic meters per minute
SM3/S	Standard cubic meters per second
SPECL	Special
ST/CUY	Short tons per cubic yard
ST/D	Short tons per day
ST/H	Short tons per hour
ST/MIN	Short tons per minute
T	Metric tons
T/D	Metric tons per day
T/H	Metric tons per hour
T/MIN	Metric tons per minute
TONUK	Long tons (2240 pounds)
TONUS	Short tons (2000 pounds)
TORR	Torr at 0 °C
UKGAL	Imperial gallons
UKGPD	Imperial gallons per day
UKGPH	imperial gallons per hour
UKGPM	Imperial gallons per minute
UKGPS	Imperial gallons per second
UMHO	Microsiemens
uSEC	Microseconds
USGAL	Gallons
USGPD	Gallons per day
USGPH	Gallons per hour
USGPM	Gallons per minute
USGPS	Gallons per second

Table B-3: Display codes for measurement units (continued)

Code	Measurement unit
V	Volts

Table B-4: Display codes for menus, controls, and data

Code	Definition
12 mA	12 mA value
20 mA	20 mA value
20 mA	20 mA
4 mA	4 mA value
4 mA	4 mA
ABORT	Abort
ACCPT	Accept
ACK	Acknowledge
ACK ALL?	Acknowledge all
ACTIV	Active
ADDR	Address
ALARM	Alert
ALL	All
ALT	Altitude
ANTHR	Another
AO 1	mA Output 1
AO 1 SRC	mA Output 1 Source
AO 2	mA Output 2
AO 2 SRC	mA Output 2 Source
API	API (American Petroleum Institute)
APPLY	Apply
ASCII	ASCII
AUTO	Auto
AUTOSCRL	Auto Scroll
AVG	Average
BASE	Base
BDENS	Base Density
BRD T	Board temperature
CAL	Calibrate or Calibration
CAL	Calibration result
CALC	Calculate

Table B-4: Display codes for menus, controls, and data (continued)

Code	Definition
CCAI	Calculated Carbon Aromaticity Index
CH B	Channel B
CHANGE	Change
CHMBR	Chamber
CII	Calculated Ignition Index
CO	Carbon monoxide
CO2	Carbon dioxide
CODE?	Passcode
CONC	Concentration
CONCENTR	Concentration
CONFG	Configure or Configuration
CONFIG	Configure or Configuration
COR M	Mass flow rate from Coriolis input
COR V	Volume flow rate calculated from Coriolis input
CUR Z	Current zero value
CURVE	Matrix
CUSTD	Custody transfer (Weights & Measures)
CUSTODY XFER	Custody transfer (Weights & Measures)
CV	Calorific value
DENS	Density
DEV	Maximum deviation
DGAIN	Drive gain
DISBL	Disabled
DISPLAY	Display
DO	Discrete Output
DO SRC	Discrete Output Source
DRIVE	Drive gain
DRIVE%	Drive gain
DSPLY	Display
DYNV	Dynamic viscosity
ENABL	Enabled
ENGL	English
ENRGY	Energy
ENTER	Enter
ETO	Engineer To Order
EVNT1	Enhanced event 1

Table B-4: Display codes for menus, controls, and data (continued)

Code	Definition
EVNT2	Enhanced event 2
EVNT3	Enhanced event 3
EVNT4	Enhanced event 4
EVNT5	Enhanced event 5
EXIT	Exit
EXT P	External or fixed pressure
EXT T	External or fixed temperature
FAC Z	Factory zero value
FACT	Factor
FACTORY	Factory
FAIL	Fail
FAULT	Fault
FCTOR	Factor
FILL	Fill
FIX	Fix
FREN	French
GAS	Gas
GER	German
GOOD	Good
H2	Hydrogen
HART	HART
HIDE	Hide
HIGH	High
IO	Input/Output
K VAL	K value
K0	K0 calibration factor
K1	K1 calibration factor
K2	K2 calibration factor
KDV	Known Density Verification
KINV	Kinematic viscosity
LANG	Language
LANGUAGE	Language
LOADING	Loading
LOW	Low
MAG M	Mass flow rate calculated from external volume input
MAG V	Volume flow rate from external input

Table B-4: Display codes for menus, controls, and data (continued)

Code	Definition
MAINT	Maintenance
MAO 1	mA Output 1
MAO 2	mA Output 2
MASS	Mass
MBUS	Modbus
MDIUM	Medium
MEASR	Measurement
MMI	Micro Motion
mS	Millisecond
MTR F	Meter factor
MW	Molecular weight
N2	Nitrogen
NET M	Net mass flow rate
NET V	Net volume flow rate
NO	No
nSEC	Nanoseconds
NUMBR	Number
OFF	Off
OFF-LINE	Offline
OFFLN	Offline
OFFSET	Offset
OFFST	Offset
ON	On
O-O-O-O	HART Squawk display
OOR	Out of range
PASS	Password or passcode
PASSW	Password or passcode
POLAR	Polarity
POLARITY	Polarity
POOR	Poor
PTS	Time period signal
Q FCTOR	Quality Factor
RANG	Range
RATE	Scroll Rate or Display Rate
RD	Relative density
RDENS	Referred density

Table B-4: Display codes for menus, controls, and data (continued)

Code	Definition
REF	Reference or Referred
RESTORE	Restore
RESULT	Result
RTEMP	Reference temperature
RUN	Run
RVISC	Referred viscosity
SAVE	Save
SCALE	Scale
SCL F	Dynamic viscosity scale factor
SCREEN	Screen
SCRLL	Scroll
SCROLL	Scroll
SECURE	Secure mode enabled
SEE	See
SELECT	Select
SET	Set, Set simulated value, Set configuration value
SETPOINT	Setpoint
SG	Specific gravity
SGU	Specific gravity
SHOW	Show
SIM	Simulate, Simulated
SLOPE	Slope
SPAN	Spanish
SRC	Source
SRVIS	Secondary referred viscosity
STAB	Stability
START	Start
STORE	Store
SW	Software
SWREV	Software revision
TCASE	Case temperature
TDIFF	Tube-Case Temperature Difference
TEMP	Temperature
TP	Time Period
TP A	Sensor Time Period (Upper)
TP B	Sensor Time Period

Table B-4: Display codes for menus, controls, and data (continued)

Code	Definition
TPS	Time Period Signal
TYPE	Type
UCALC	User-defined calculation
ULTRA	Ultra-low
UNITS	Units
VEL	Velocity
VELSW	Flow switch or velocity switch
VERSION_STRING	Revision or Version
VISC	Viscosity
VOL	Volume
VOLTS	Volts
WOBBE	Wobbe index
XMTR	Transmitter
YES	Yes
YES?	Confirm
Z	Compressibility
ZERO	Zero

Appendix C

Using ProLink III with the transmitter

Topics covered in this appendix:

- [Basic information about ProLink III](#)
- [Connect with ProLink III](#)

C.1 Basic information about ProLink III

ProLink III is a configuration and service tool available from Micro Motion. It runs on a Windows platform and provides complete access to transmitter functions and data.

Version requirements

The following version of ProLink III is required: v3.2 or later.

ProLink III requirements

To install ProLink III, you must have:

- The ProLink III installation media
- The ProLink III installation kit for your connection type:
 - Converter: RS-232 to RS-485, or RS-232 to Bell 202
 - Cables and connectors: Serial port or USB port

To obtain ProLink III and the appropriate installation kit, contact Micro Motion.

ProLink III documentation

Most of the instructions in this manual assume that you are already familiar with ProLink III or that you have a general familiarity with Windows programs. If you need more information than this manual provides, see the ProLink III manual (*ProLink® III Configuration and Service Tool for Micro Motion® Transmitters: User Manual*).

In most ProLink III installations, the manual is installed with the ProLink III program. Additionally, the ProLink III manual is available on the Micro Motion documentation CD or the Micro Motion web site (www.micromotion.com).

ProLink III features and functions

ProLink III offers complete transmitter configuration and operation functions. ProLink III also offers a number of additional features and functions, including:

- The ability to save the transmitter configuration set to a file on the PC, and reload it or propagate it to other transmitters
- The ability to log specific types of data to a file on the PC
- The ability to view performance trends for various types of data on the PC

- The ability to connect to and view information for more than one device
- A guided connection wizard

These features are documented in the ProLink III manual. They are not documented in the current manual.

ProLink III messages

As you use ProLink III with a Micro Motion transmitter, you will see a number of messages and notes. This manual does not document all of these messages and notes.

Important

The user is responsible for responding to messages and notes and complying with all safety messages.

C.2 Connect with ProLink III

A connection from ProLink III to your transmitter allows you to read process data, configure the transmitter, and perform maintenance and troubleshooting tasks.

- [Connection types supported by ProLink III](#) (Section C.2.1)
- [Connect with ProLink III over Modbus/RS-485](#) (Section C.2.2)
- [Connect with ProLink III over HART/Bell 202](#) (Section C.2.3)

C.2.1 Connection types supported by ProLink III

Different connection types are available for connecting from ProLink III to the transmitter. Choose the connection type appropriate to your network and the tasks you intend to perform.

The transmitter supports the following ProLink III connection types:

- Service port connections
- HART/Bell 202 connections
- Modbus/RS-485 8-bit connections (Modbus RTU)
- Modbus/RS-485 7-bit connections (Modbus ASCII)

When selecting a connection type, consider the following:

- Service port connections are specialized Modbus/RS-485 connections that use standard connection parameters and a standard address that are already defined in ProLink III. Service port connections are typically used by field service personnel for specific maintenance and diagnostic functions. Use a service port connection only when another connection type does not provide the functionality you need.
- Some connection types require opening the wiring compartment or the power supply compartment. These connection types should be used only for temporary connections, and may require extra safety precautions.

- Modbus connections, including service port connections, are typically faster than HART connections.
- When you are using a HART connection, ProLink III will not allow you to open more than one window at a time. This is done to manage network traffic and optimize speed.
- You cannot make concurrent Modbus connections if the connections use the same terminals. You can make concurrent Modbus connections if the connections use different terminals.

C.2.2 Connect with ProLink III over Modbus/RS-485

You can connect directly to the RS-485 terminals on the transmitter or to any point on the network.

CAUTION!

If the transmitter is in a hazardous area, do not remove the transmitter end-cap while the transmitter is powered up. Removing the end cap while the transmitter is powered up could cause an explosion. To connect to the transmitter in a hazardous environment, use a connection method that does not require removing the transmitter end-cap.

Prerequisites

- ProLink III v3.2 or later installed and licensed on your PC
- An available serial port or USB port
- The installation kit appropriate to your connection type (RS-485 or Bell 202, serial port or USB)
- Adapters as required (for example, 9-pin to 25-pin)

Procedure

1. Attach the signal converter to the serial port or USB port on your PC.
2. To connect directly to the transmitter terminals:
 - a. Remove the transmitter end-cap to access the wiring compartment.
 - b. Connect the leads from the signal converter to the RS-485 terminals.

Tip

Usually, but not always, you should connect the black lead to the A terminal and the red lead to the B terminal.

Figure C-1: Connection to RS-485 terminals

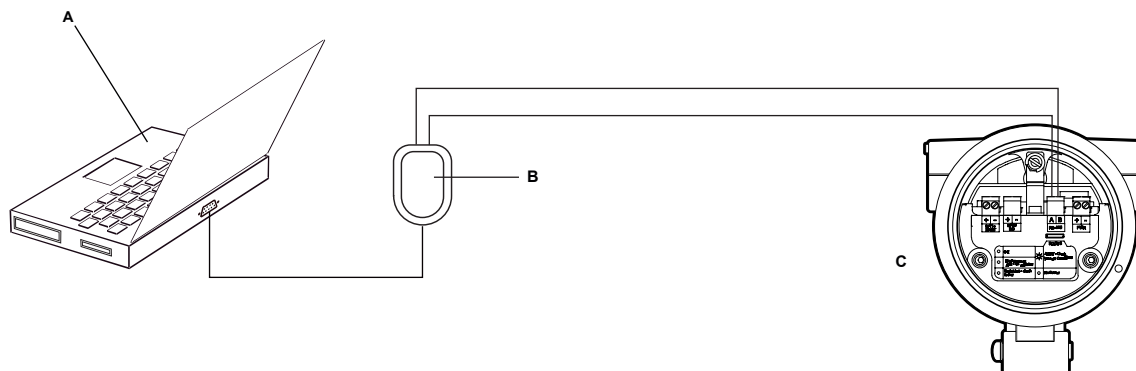

- A. PC
- B. RS-232 to RS-485 converter
- C. Transmitter with end-cap removed

Note

This figure shows a serial port connection. USB connections are also supported.

3. To connect over the RS-485 network:
 - a. Attach the leads from the signal converter to any point on the network.
 - b. Add resistance as necessary.
 - c. Ensure that the PLC or DCS is not trying to communicate to this meter at this time.

Restriction

The meter does not support concurrent connections from ProLink III and a PLC or DCS. If another host is already communicating with the meter, ProLink III will not be able to connect, but its connection attempts will corrupt messages from the other host. To make a ProLink III connection, disconnect the cable from the host.

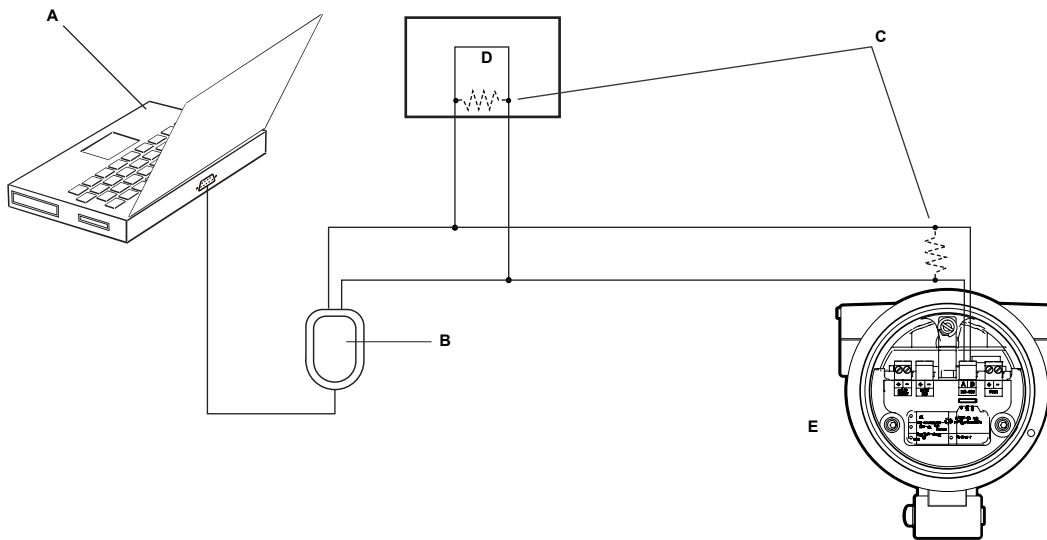
Figure C-2: Connection over network

- A. PC
- B. RS-232 to RS-485 converter
- C. 120- Ω , 1/2-watt resistors at both ends of the segment, if necessary
- D. DCS or PLC
- E. Transmitter with end-cap removed

Note

This figure shows a serial port connection. USB connections are also supported.

4. Start ProLink III.
5. Choose Connect to Physical Device.
6. Set the parameters that are required for your connection type.

Table C-1: RS-485 connection parameters

Connection type	Parameter	Value	Optional or required?	Auto-detection
Service port	Protocol	Service Port	Required	No
	PC Port	The PC port that you are using for this connection.	Required	No
Modbus/RS-485	Protocol	Modbus RTU or Modbus ASCII	Required	Yes. The device accepts connection requests that use either protocol, and responds using the same protocol.
	PC Port	The PC port that you are using for this connection.	Required	No
	Address	The Modbus address configured for this transmitter. The default is 1.	Required	No

Table C-1: RS-485 connection parameters (continued)

Connection type	Parameter	Value	Optional or required?	Auto-detection
	Baud Rate	1200 to 38400	Optional	Yes. The device accepts connection requests that use any valid setting, and responds using the same setting.
	Parity	None, Odd, Even	Optional	Yes. The device accepts connection requests that use any valid setting, and responds using the same setting.
	Stop Bits	1 or 2	Optional	Yes. The device accepts connection requests that use any valid setting, and responds using the same setting.

- Click Connect.

Need help?

If an error message appears:

- Switch the leads and try again.
- Verify the Modbus address of the transmitter.
- Ensure that you have specified the correct port on your PC.
- Check the wiring between the PC and the transmitter.
- For long-distance communication, or if noise from an external source interferes with the signal, install 120- Ω ½-W terminating resistors in parallel with the output at both ends of the communication segment.
- Ensure that there is no concurrent Modbus communication to the transmitter.

C.2.3 Connect with ProLink III over HART/Bell 202

You can connect directly to the primary mA terminals on the transmitter, to any point in a local HART loop, or to any point in a HART multidrop network.

CAUTION!

If the transmitter is in a hazardous area, do not remove the transmitter end-cap while the transmitter is powered up. Removing the end cap while the transmitter is powered up could cause an explosion. To connect to the transmitter in a hazardous environment, use a connection method that does not require removing the transmitter end-cap.

⚠ CAUTION!

If you connect directly to the mA terminals, the transmitter's mA output may be affected. If you are using the mA output for process control, set devices for manual control before connecting directly to the mA terminals.

Prerequisites

- ProLink III v3.2 or later installed and licensed on your PC
- An available serial port or USB port
- The installation kit appropriate to your connection type (RS-485 or Bell 202, serial port or USB)
- Adapters as required (for example, 9-pin to 25-pin)

Procedure

1. Attach the signal converter to the serial port or USB port on your PC.
2. To connect directly to the transmitter terminals:
 - a. Remove the transmitter end-cap to access the wiring compartment.
 - b. Connect the leads from the signal converter to terminals 1 and 2.

Note

HART connections are not polarity-sensitive. It does not matter which lead you attach to which terminal.

- c. Add resistance as necessary to achieve at least one volt across the connection points.

Important

HART/Bell 202 connections require a voltage drop of 1 VDC. To achieve this, add resistance of 250–600 Ω to the connection.

Figure C-3: Connection to mA output terminals

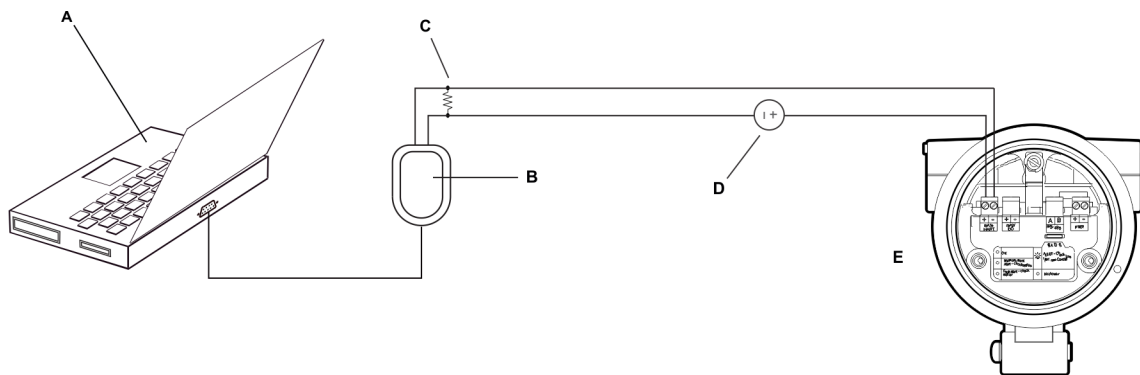

- A. PC
- B. RS-232 to Bell 202 converter
- C. 250–600 Ω resistance
- D. External power supply
- E. Transmitter with end-cap removed

Note

This figure shows a serial port connection. USB connections are also supported.

The signal converter must be connected across a resistance of 250–600 Ω . The mA output requires an external power supply with a minimum of 250 Ω and 17.5 V. See the following figure to help determine the appropriate combination of voltage and resistance. Note that many PLCs have a built-in 250- Ω resistor. If the PLC is powering the circuit, be sure to take this into consideration.

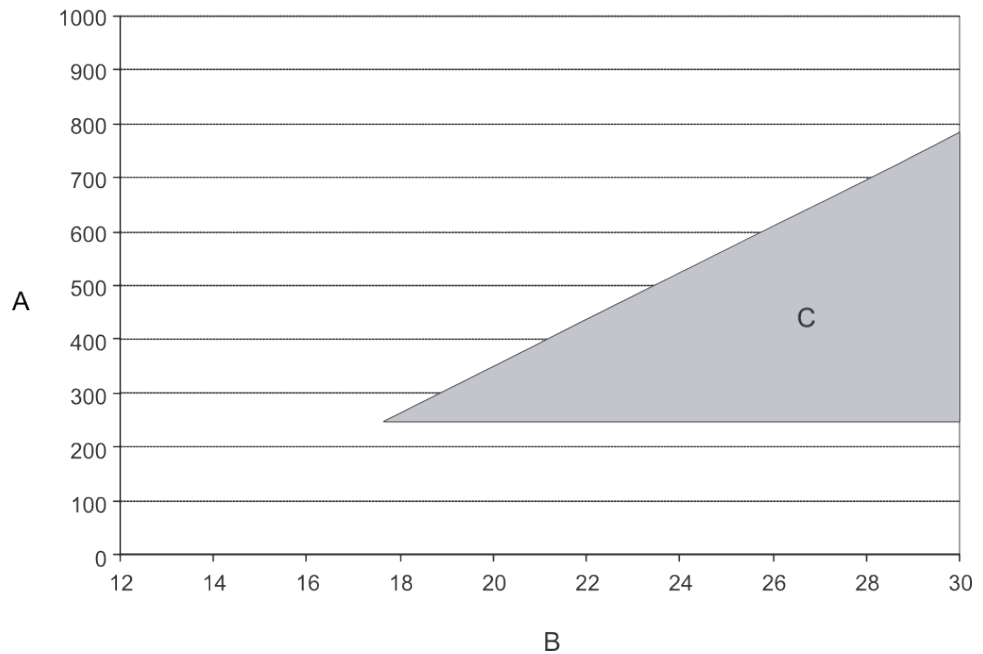
Figure C-4: Supply voltage and resistance requirements

- A. External resistance (ohms)
 B. Supply voltage VDC (volts)
 C. Operating range

Note

$$R_{\max} = \frac{(V_{\text{supply}} - 12)}{0.023}$$

3. To connect to a point in the local HART loop:
 - a. Attach the leads from the signal converter to any point in the loop, ensuring that the leads are across the resistor.
 - b. Add resistance as necessary to achieve at least one volt across the connection points.

Important

HART/Bell 202 connections require a voltage drop of 1 VDC. To achieve this, add resistance of 250–600 Ω to the connection.

Figure C-5: Connection over local loop

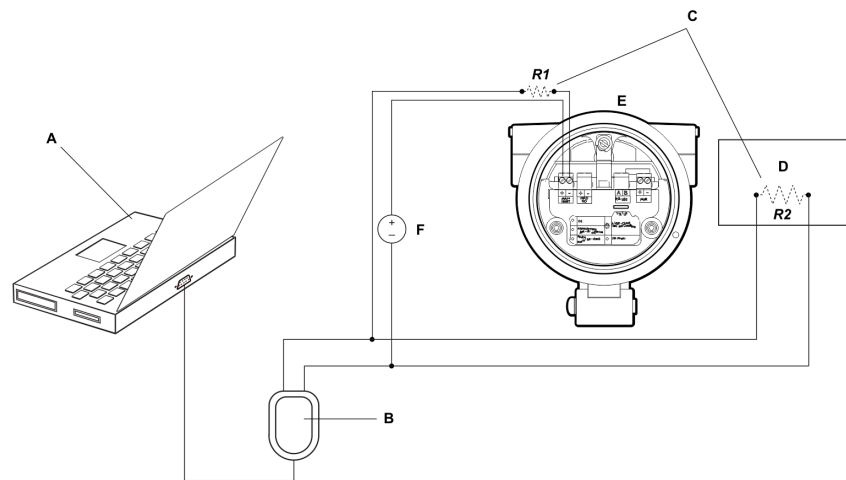

- A. PC
- B. RS-232 to Bell 202 converter
- C. Any combination of resistors $R1$ and $R2$ as necessary to meet HART communication resistance requirements
- D. DCS or PLC
- E. Transmitter with end-cap removed
- F. External power supply

Note

This figure shows a serial port connection. USB connections are also supported.

The signal converter must be connected across a resistance of 250–600 Ω . The mA output requires an external power supply with a minimum of 250 Ω and 17.5 V. See the following figure to help determine the appropriate combination of voltage and resistance. Note that many PLCs have a built-in 250- Ω resistor. If the PLC is powering the circuit, be sure to take this into consideration.

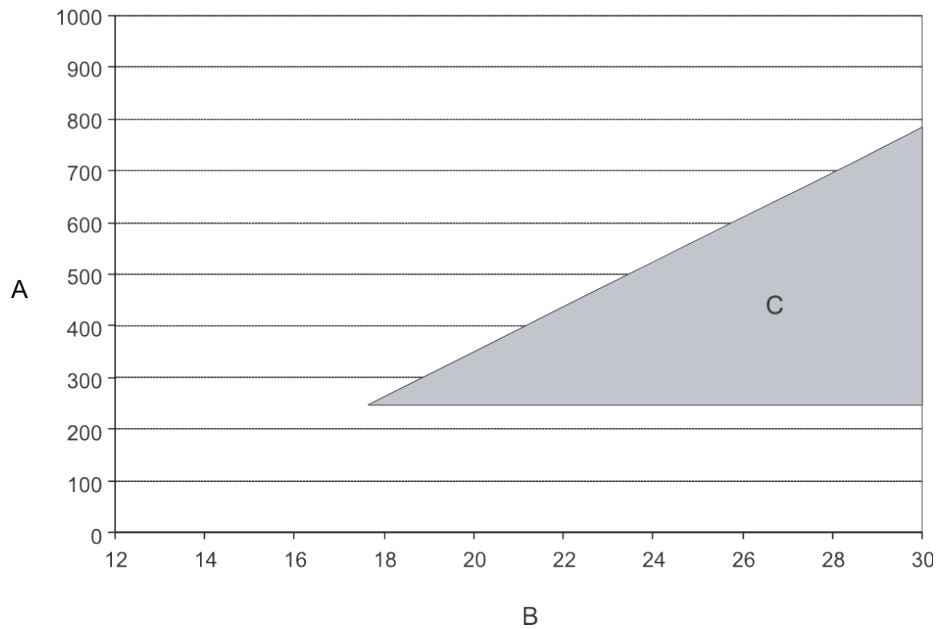
Figure C-6: Supply voltage and resistance requirements

- A. External resistance (ohms)
 B. Supply voltage VDC (volts)
 C. Operating range

Note

$$R_{\max} = \frac{(V_{\text{supply}} - 12)}{0.023}$$

4. To connect over a HART multidrop network:
 - a. Attach the leads from the signal converter to any point in the loop.
 - b. Add resistance as necessary to achieve at least one volt across the connection points.

Important

HART/Bell 202 connections require a voltage drop of 1 VDC. To achieve this, add resistance of 250–600 Ω to the connection.

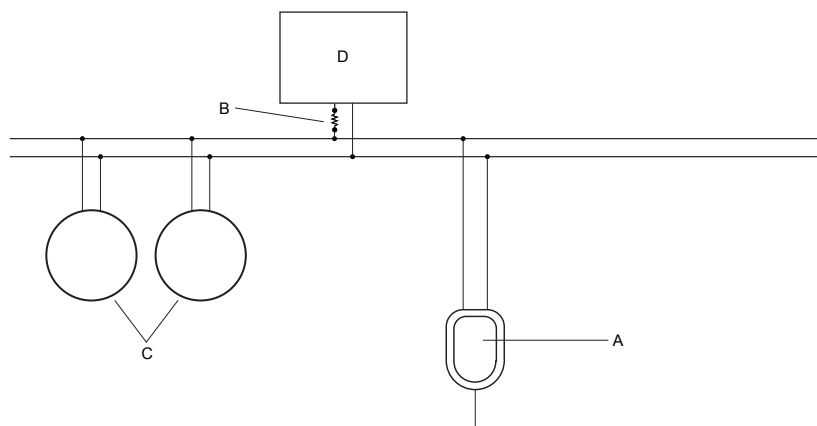
Figure C-7: Connection over multidrop network

- A. RS-232 to Bell 202 converter
 B. 250–600 Ω resistance
 C. Devices on the network
 D. Master device

5. Start ProLink III.
6. Choose Connect to Physical Device.
7. Set Protocol to HART Bell 202.

Tip

HART/Bell 202 connections use standard connection parameters. You do not need to configure them here.

8. If you are using a USB signal converter, enable Toggle RTS.
9. Set Address/Tag to the HART polling address configured in the transmitter.

Tips

- If this is the first time you are connecting to the transmitter, use the default address: 0.
- If you are not in a HART multidrop environment, the HART polling address is typically left at the default value.
- If you are unsure of the transmitter's address, click Poll. The program will search the network and return a list of the transmitters that it detects.

10. Set the PC Port value to the PC COM port that you are using for this connection.
11. Set Master as appropriate.

Option	Description
Secondary	Use this setting if a primary HART host such as a DCS is on the network.
Primary	Use this setting if no other primary host is on the network. The Field Communicator is a secondary host.

12. Click Connect.

Need help? If an error message appears:

- Verify the HART address of the transmitter, or poll HART addresses 1–15.
- Ensure that there is at least 1 VDC across the connection terminals. Add resistance as necessary to achieve at least 1 volt.
- Ensure that you have specified the correct port on your PC.
- Check the wiring between the PC and the transmitter.
- Ensure that the mA output is powered.
- Increase or decrease resistance.
- Disable burst mode.
- Ensure that the resistor is installed correctly. If the mA output is internally powered (active), the resistor must be installed in parallel. If the mA output is externally powered (passive), the resistor must be installed in series.
- Ensure that there is no conflict with another HART master. If any other host (DCS or PLC) is connected to the mA output, temporarily disconnect the DCS or PLC wiring.

Appendix D

Using the Field Communicator with the transmitter

Topics covered in this appendix:

- *Basic information about the Field Communicator*
- *Connect with the Field Communicator*

D.1 Basic information about the Field Communicator

The Field Communicator is a handheld configuration and management tool that can be used with a variety of devices, including Micro Motion transmitters. It provides complete access to transmitter functions and data.

Field Communicator documentation

Most of the instructions in this manual assume that you are already familiar with the Field Communicator and can perform the following tasks:

- Turn on the Field Communicator
- Navigate the Field Communicator menus
- Establish communication with HART-compatible devices
- Send configuration data to the device
- Use the alpha keys to enter information

If you are unable to perform these tasks, consult the Field Communicator manual before attempting to use the Field Communicator. The Field Communicator manual is available on the Micro Motion documentation CD or the Micro Motion web site (www.micromotion.com).

Device descriptions (DDs)

In order for the Field Communicator to work with your device, the appropriate device description (DD) must be installed. This meter requires the following HART device description: Density Gas Viscosity Meter Dev v2 DD v1 or later.

To view the device descriptions that are installed on your Field Communicator:

1. At the HART application menu, press Utility > Available Device Descriptions.
2. Scroll the list of manufacturers and select Micro Motion, then scroll the list of installed device descriptions.

If Micro Motion is not listed, or you do not see the required device description, use the Field Communicator Easy Upgrade Utility to install the device description, or contact Micro Motion.

Field Communicator menus and messages

Many of the menus in this manual start with the On-Line menu. Ensure that you are able to navigate to the On-Line menu.

As you use the Field Communicator with a Micro Motion transmitter, you will see a number of messages and notes. This manual does not document all of these messages and notes.

Important

The user is responsible for responding to messages and notes and complying with all safety messages.

D.2 Connect with the Field Communicator

A connection from the Field Communicator to your transmitter allows you to read process data, configure the transmitter, and perform maintenance and troubleshooting tasks.

You can connect the Field Communicator to the primary mA terminals on the transmitter, to any point in a local HART loop, or to any point in a HART multidrop network.

CAUTION!

If the transmitter is in a hazardous area, do not connect the Field Communicator to the mA terminals on the transmitter. This connection requires opening the wiring compartment, and opening the wiring compartment in a hazardous area can cause an explosion.

Important

If the HART security switch is set to ON, HART protocol cannot be used to perform any action that requires writing to the transmitter. For example, you cannot change the configuration, reset totalizers, or perform calibration using the Field Communicator or ProLink II with a HART connection. When the HART security switch is set to OFF, no functions are disabled.

Prerequisites

The following HART device description (DD) must be installed on the Field Communicator: Density Gas Viscosity Meter Dev v2 DD v1 or later.

Procedure

1. To connect to the transmitter terminals:
 - a. Remove the transmitter end-cap.
 - b. Attach the leads from the Field Communicator to terminals 1 and 2 on the transmitter and add resistance as required.

The Field Communicator must be connected across a resistance of 250–600 Ω .

Tip

HART connections are not polarity-sensitive. It does not matter which lead you attach to which terminal.

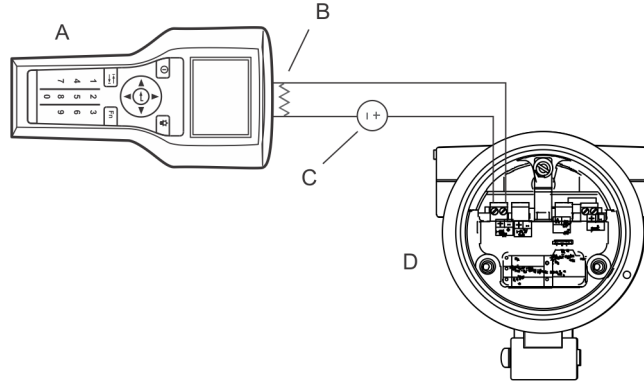
Figure D-1: Field Communicator connection to transmitter terminals

- A. Field Communicator
- B. 250–600 Ω resistance
- C. External power supply
- D. Transmitter with end-cap removed

2. To connect to a point in the local HART loop, attach the leads from the Field Communicator to any point in the loop and add resistance as necessary.

The Field Communicator must be connected across a resistance of 250–600 Ω .

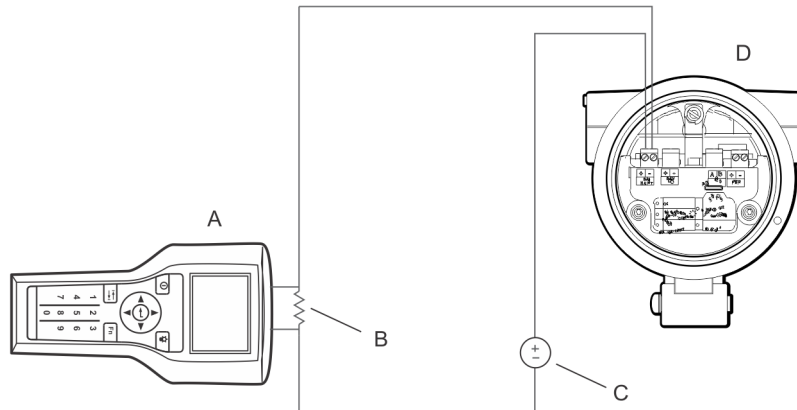
Figure D-2: Field Communicator connection to local HART loop

- A. Field Communicator
- B. 250–600 Ω resistance
- C. External power supply
- D. Transmitter with end-cap removed

3. To connect to a point in the HART multidrop network, attach the leads from the Field Communicator to any point on the network.

Figure D-3: Field Communicator connection to multidrop network

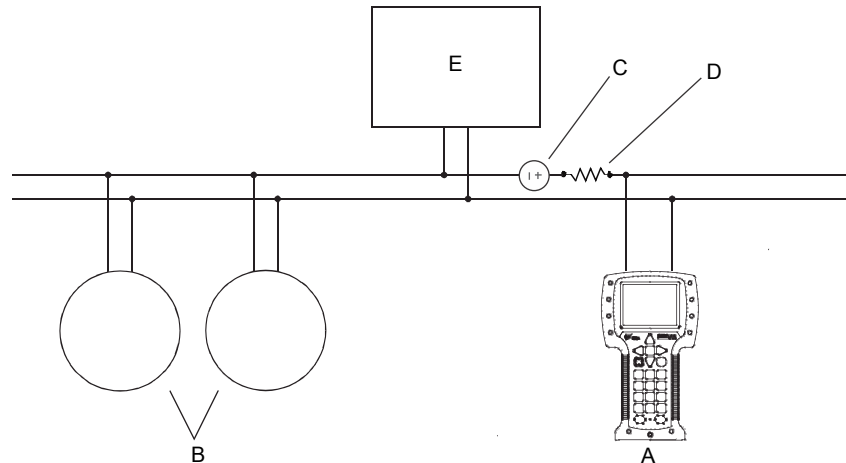

- A. Field Communicator
- B. Devices on the network
- C. External power supply (may be provided by the PLC)
- D. 250–600 Ω resistance (may be provided by the PLC)
- E. Master device

4. Turn on the Field Communicator and wait until the main menu is displayed.
5. If you are connecting across a multidrop network:
 - Set the Field Communicator to poll. The device returns all valid addresses.
 - Enter the HART address of the transmitter. The default HART address is 0. However, in a multidrop network, the HART address has probably been set to a different, unique value.

Postrequisites

To navigate to the Online menu, choose HART Application > Online. Most configuration, maintenance, and troubleshooting tasks are performed from the Online menu.

Tip

You may see messages related to the DD or active alerts. Press the appropriate buttons to ignore the message and continue.

Need help?

The Field Communicator requires a minimum of 1 VDC across the connection leads to communicate. If necessary, increase the resistance at the connection point until 1 VDC is achieved.

Appendix E

Concentration measurement matrices, derived variables, and process variables

Topics covered in this appendix:

- [Standard matrices for the concentration measurement application](#)
- [Concentration measurement matrices available by order](#)
- [Derived variables and calculated process variables](#)

E.1 Standard matrices for the concentration measurement application

The standard concentration matrices available from Micro Motion are applicable for a variety of process fluids. These matrices are included in the ProLink III installation.

Tip

If the standard matrices are not appropriate for your application, you can build a custom matrix or purchase a custom matrix from Micro Motion.

Table E-1: Standard concentration matrices and associated measurement units

Matrix name	Description	Density unit	Temperature unit	Derived variable
Deg Balling	Matrix represents percent extract, by mass, in solution, based on °Balling. For example, if a wort is 10 °Balling and the extract in solution is 100% sucrose, the extract is 10% of the total mass.	g/cm ³	°F	Mass Concentration (Density)
Deg Brix	Matrix represents a hydrometer scale for sucrose solutions that indicates the percent by mass of sucrose in solution at a given temperature. For example, 40 kg of sucrose mixed with 60 kg of water results in a 40 °Brix solution.	g/cm ³	°C	Mass Concentration (Density)
Deg Plato	Matrix represents percent extract, by mass, in solution, based on °Plato. For example, if a wort is 10 °Plato and the extract in solution is 100% sucrose, the extract is 10% of the total mass.	g/cm ³	°F	Mass Concentration (Density)

Table E-1: Standard concentration matrices and associated measurement units (continued)

Matrix name	Description	Density unit	Temperature unit	Derived variable
HFCS 42	Matrix represents a hydrometer scale for HFCS 42 (high-fructose corn syrup) solutions that indicates the percent by mass of HFCS in solution.	g/cm ³	°C	Mass Concentration (Density)
HFCS 55	Matrix represents a hydrometer scale for HFCS 55 (high-fructose corn syrup) solutions that indicates the percent by mass of HFCS in solution.	g/cm ³	°C	Mass Concentration (Density)
HFCS 90	Matrix represents a hydrometer scale for HFCS 90 (high-fructose corn syrup) solutions that indicates the percent by mass of HFCS in solution.	g/cm ³	°C	Mass Concentration (Density)

E.2 Concentration measurement matrices available by order

Depending on your product, you may be able to order one or more of the matrices listed here. You can have it loaded at the factory or you can load it from a file.

Table E-2: Concentration matrices, names, ranges, units, and derived variable

Process fluid	Matrix file name	Default matrix name	Concentration range	Temperature range	Density unit	Temperature unit	Derived variable
Alcohol (by volume)	Alcohol 0–20%Vol 0–40C.xml	Alcohol	0–20% (by volume)	0–40 °C	g/cm ³	°C	Concentration (Density)
	Alcohol 50–100%Vol 40–70C.xml	Alcohol	50–100% (by volume)	40–70 °C	g/cm ³	°C	Concentration (Density)
	Alcohol 80–100%Vol 50–90C.xml	Alcohol	80–100% (by volume)	50–90 °C	g/cm ³	°C	Concentration (Density)
Alcohol (proof)	Alcohol 100–200 Proof 50–70C.xml	Alcohol	100–200 (proof)	50–70 °C	g/cm ³	°C	Concentration (Density)
	Alcohol 160–200 Proof 50–90C.xml	Alcohol	160–200 (proof)	50–90 °C	g/cm ³	°C	Concentration (Density)
Sucrose solution (Brix)	Sucrose 0–40 Brix 0–100C.xml	Sucrose	0–40%	0–100 °C	g/cm ³	°C	Concentration (Density)

Table E-2: Concentration matrices, names, ranges, units, and derived variable (continued)

Process fluid	Matrix file name	Default matrix name	Concentration range	Temperature range	Density unit	Temperature unit	Derived variable
	Sucrose 30–80 Brix 0–100C.xml	Sucrose	30–80%	0–100 °C	g/cm ³	°C	Concentration (Density)
Sucrose solution (Balling)	Sucrose 0–20 Balling 0–100C.xml	Sucrose	0–20 °Balling	0–100 °C	g/cm ³	°C	Concentration (Density)
Sodium hydroxide (NaOH)	NaOH 0–20% 0–50C.xml	NaOH	0–20%	0– 50 °C	g/cm ³	°C	Concentration (Density)
	NaOH 0–50% 0–80C.xml	NaOH	0–50%	0–80 °C	g/cm ³	°C	Concentration (Density)
	NaOH 0–74% 80–100C.xml	NaOH	0–74%	80–100 °C	g/cm ³	°C	Concentration (Density)
Sulfuric acid (H ₂ SO ₄)	H2SO4 75–94% 24–38C.xml	H2SO4	75–94%	24–38 °C	g/cm ³	°C	Concentration (Density)
	H2SO4 0–10% 0–38C.xml	H2SO4	0–10%	0–38 °C	g/cm ³	°C	Concentration (Density)
	H2SO4 0–20% 0–24c.xml	H2SO4	0–20%	0–24 °C	g/cm ³	°C	Concentration (Density)
	H2SO4 0–93% 0–38C.xml	H2SO4	0–93%	0–38 °C	g/cm ³	°C	Concentration (Density)
	H2SO4 0–25% 0–50C.xml	H2SO4	0–25%	0–50 °C	g/cm ³	°C	Concentration (Density)
Nitric acid (HNO ₃)	HNO3 0–40% 10–50C.xml	HNO3	0–40%	10–50 °C	g/cm ³	°C	Concentration (Density)
	HNO3 0–70% 0–50C.xml	HNO3	0–70%	0–50 °C	g/cm ³	°C	Concentration (Density)
	HNO3 0–100% 5–30C.xml	HNO3	0–100%	5–30 °C	g/cm ³	°C	Concentration (Density)
Potassium hydroxide (KOH)	KOH 0–40% 0–90C.xml	KOH	0–40%	0–90 °C	g/cm ³	°C	Concentration (Density)
High-fructose corn syrup	HFCS 42 0–50% 0–100C.xml	HFCS 42	0–50%	0–100 °C	g/cm ³	°C	Concentration (Density)
	HFCS 55 0–50% 0–100c.xml	HFCS 55	0–50%	0–100 °C	g/cm ³	°C	Concentration (Density)
	HFCS 90 0–50% 0–100c.xml	HFCS 90	0–50%	0–100 °C	g/cm ³	°C	Concentration (Density)
Wort	Plato 0–30 Plato 0–100C.xml	Plato	0–30 °Plato	0–100 °C	g/cm ³	°C	Concentration (Density)
Hydrochloric acid (HCl)	HCl 0–5% 0–90C.xml	HCl	0–5%	0–90 °C	g/cm ³	°C	Concentration (Density)

Table E-2: Concentration matrices, names, ranges, units, and derived variable (continued)

Process fluid	Matrix file name	Default matrix name	Concentration range	Temperature range	Density unit	Temperature unit	Derived variable
	HCl 0–32% 0–49C.xml	HCl	0–32%	0–49 °C	g/cm ³	°C	Concentration (Density)
Methanol	Methanol 35–60% 0–40C.xml	Methanol	35–60%	0–40 °C	g/cm ³	°C	Concentration (Density)
Ethylene glycol	Ethylene Glycol 10–50% –20 –40C.xml	Eth. Glycol	10–50%	–20 – +40 °C	g/cm ³	°C	Concentration (Density)

E.3 Derived variables and calculated process variables

The concentration measurement application calculates a different set of process variables from each derived variable. The process variables are then available for viewing or reporting.

Table E-3: Derived variables and calculated process variables

Derived Variable	Description	Calculated process variables					
		Density at reference temperature	Standard volume flow rate	Specific gravity	Concentration	Net mass flow rate	Net volume flow rate
Density at Reference	Mass/unit volume, corrected to a given reference temperature	✓	✓				
Specific Gravity	The ratio of the density of a process fluid at a given temperature to the density of water at a given temperature. The two given temperature conditions do not need to be the same.	✓	✓	✓			
Mass Concentration (Density)	The percent mass of solute or of material in suspension in the total solution, derived from reference density	✓	✓		✓	✓	

Table E-3: Derived variables and calculated process variables (continued)

Derived Variable	Description	Calculated process variables					
		Density at reference temperature	Standard volume flow rate	Specific gravity	Concentration	Net mass flow rate	Net volume flow rate
Mass Concentration (Specific Gravity)	The percent mass of solute or of material in suspension in the total solution, derived from specific gravity	✓	✓	✓	✓	✓	
Volume Concentration (Density)	The percent volume of solute or of material in suspension in the total solution, derived from reference density	✓	✓		✓		✓
Volume Concentration (Specific Gravity)	The percent volume of solute or of material in suspension in the total solution, derived from specific gravity	✓	✓	✓	✓		✓
Concentration (Density)	The mass, volume, weight, or number of moles of solute or of material in suspension in proportion to the total solution, derived from reference density	✓	✓		✓		
Concentration (Specific Gravity)	The mass, volume, weight, or number of moles of solute or of material in suspension in proportion to the total solution, derived from specific gravity	✓	✓	✓	✓		



MMI-20020959

Rev AC

2016

Micro Motion Inc. USA

Worldwide Headquarters
7070 Winchester Circle
Boulder, Colorado 80301
T +1 303-527-5200
T +1 800-522-6277
F +1 303-530-8459

www.micromotion.com

Micro Motion Europe

Emerson Process Management
Neonstraat 1
6718 WX Ede
The Netherlands
T +31 (0) 70 413 6666
F +31 (0) 318 495 556

www.micromotion.nl

Micro Motion Asia

Emerson Process Management
1 Pandan Crescent
Singapore 128461
Republic of Singapore
T +65 6777-8211
F +65 6770-8003

Micro Motion United Kingdom

Emerson Process Management Limited
Horsfield Way
Bredbury Industrial Estate
Stockport SK6 2SU U.K.
T +44 0870 240 1978
F +44 0800 966 181

Micro Motion Japan

Emerson Process Management
1-2-5, Higashi Shinagawa
Shinagawa-ku
Tokyo 140-0002 Japan
T +81 3 5769-6803
F +81 3 5769-6844

©2016 Micro Motion, Inc. All rights reserved.

The Emerson logo is a trademark and service mark of Emerson Electric Co. Micro Motion, ELITE, ProLink, MVD and MVD Direct Connect marks are marks of one of the Emerson Process Management family of companies. All other marks are property of their respective owners.

MICRO MOTION™

