

# XMO2pro

## Oxygen Analyzer

### User's Manual





# **XMO2pro**

*Oxygen Analyzer*

## **User's Manual**

BH079C11 Rev. A  
March 2025

[panametrics.com](https://panametrics.com)

Copyright 2025 Baker Hughes company.

This material contains one or more registered trademarks of Baker Hughes Company and its subsidiaries in one or more countries. All third-party product and company names are trademarks of their respective holders.

[no content intended for this page]

## Services



Panametrics provides customers with an experienced staff of customer support personnel ready to respond to technical inquiries, as well as other remote and on-site support needs. To complement our broad portfolio of industry-leading solutions, we offer several types of flexible and scalable support services including: Training, Product Repairs, Service Agreements and more.

Please visit <https://www.bakerhughes.com/panametrics/panametrics-services> for more details.

## Typographical Conventions

**Note:** These paragraphs provide information that provides a deeper understanding of the situation, but is not essential to the proper completion of the instructions.

**IMPORTANT:** These paragraphs provide information that emphasizes instructions that are essential to proper setup of the equipment. Failure to follow these instructions carefully may cause unreliable performance.



**CAUTION!** This symbol indicates a risk of potential minor personal injury and/or severe damage to the equipment, unless these instructions are followed carefully.



**WARNING!** This symbol indicates a risk of potential serious personal injury, unless these instructions are followed carefully.

## Safety Issues



**WARNING!** It is the responsibility of the user to make sure all local, county, state and national codes, regulations, rules and laws related to safety and safe operating conditions are met for each installation.



**Attention European Customers!** To meet CE Mark requirements for all units intended for use in the EU, all electrical cables must be installed as described in this manual.

## Auxiliary Equipment

### Local Safety Standards

The user shall ensure that they operate all auxiliary equipment in accordance with all local codes, standards, regulations, and laws applicable to safety.

### Working Area



**WARNING!** Auxiliary equipment may have both manual and automatic modes of operation. As equipment can move suddenly and without warning, do not enter the work cell of this equipment during automatic operation, and do not enter the work envelope of this equipment during manual operation. If you do, serious injury can result.



**WARNING!** Make sure that power to the auxiliary equipment is turned OFF and locked out before you perform maintenance procedures on this equipment.

## Qualification of Personnel

Make sure that all personnel have manufacturer-approved training applicable to the auxiliary equipment.

## Personal Safety Equipment

Make sure that operators and maintenance personnel have all safety equipment applicable to the auxiliary equipment. Examples include safety glasses, protective headgear, safety shoes, etc.

## Unauthorized Operation

Make sure that unauthorized personnel cannot gain access to the operation of the equipment.

## Environmental Compliance

### Waste Electrical and Electronic Equipment (WEEE) Directive

Panametrics is an active participant in Europe's *Waste Electrical and Electronic Equipment (WEEE)* take-back initiative, directive 2012/19/EU.

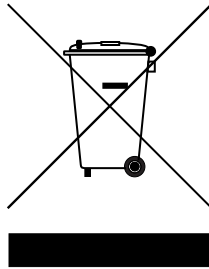

The equipment that you bought has required the extraction and use of natural resources for its production. It may contain hazardous substances that could impact health and the environment.

In order to avoid the dissemination of those substances in our environment and to diminish the pressure on the natural resources, we encourage you to use the appropriate take-back systems. Those systems will reuse or recycle most of the materials of your end-of-life equipment in an environmentally-sound way.

The crossed-out wheeled bin symbol invites you to use those systems.

If you need more information on the collection, reuse and recycling systems, please contact your local or regional waste administration.

Please visit [www.bakerhughes.com/health-safety-and-environment-hse](http://www.bakerhughes.com/health-safety-and-environment-hse) for take-back instructions and more information about this initiative.

**Chapter 1. Features and Capabilities**

1.1 Introduction .....1

1.2 Basic Features .....1

1.3 Product Overview ..... 2

1.4 Theory of Operation ..... 2

1.5 System Description ..... 3

    1.5.1 The XMO2pro Transmitter ..... 3

    1.5.2 The Sample System ..... 5

1.6 Applications ..... 5

**Chapter 2. Installation**

2.1 Introduction ..... 7

2.2 Installing the XMO2pro Transmitter ..... 7

2.3 Installing the Sample System ..... 7

    2.3.1 A Basic System ..... 7

    2.3.2 Mounting the Sample System ..... 8

2.4 Wiring the Transmitter ..... 9

    2.4.1 Grounding the Apparatus ..... 9

    2.4.2 Electromagnetic Compatibility (EMC) Performance Requirements ..... 10

    2.4.3 Cable Specifications ..... 10

        2.4.3.1 Accessing Terminal Blocks TB1, TB2, TB3, TB4, and TB10 ..... 10

    2.4.4 Wiring the Power and Signal Connections ..... 11

    2.4.5 Wiring the Alarm Relays ..... 12

2.5 Specific Conditions of Use ..... 13

**Chapter 3. Startup and Operation**

3.1 Introduction ..... 15

3.2 Powering the Analyzer ..... 15

3.3 Establishing a Sample Gas Flow ..... 15

3.4 Analog Output Calibration Options ..... 16

3.5 Factory Calibration Procedures ..... 17

3.6 Required Calibration Materials ..... 17

**Chapter 4. Programming with HMI**

4.1 The XMO2pro Keypad ..... 19

4.2 Dashboard ..... 21

4.3 About Menu ..... 21

4.4 Login Menu ..... 22

    4.4.1 Login as User ..... 23

    4.4.2 Login as Admin ..... 23

    4.4.3 Login as SIL User (SIL ONLY)\* ..... 23

    4.4.4 Change Password ..... 24

4.5 Error Handling/Alarms ..... 24

    4.5.1 Analog Alarms ..... 26

    4.5.2 Digital Alarms ..... 26

    4.5.3 Trip Points ..... 27

4.6 Display Config ..... 27

    4.6.1 Contrast Settings ..... 27

    4.6.2 Invert Display ..... 28

    4.6.3 Units ..... 28

4.7 Modbus Parameters ..... 28

    4.7.1 Mode ..... 28

    4.7.2 Port ..... 29

    4.7.3 Slave ID ..... 29

    4.7.4 Baud Rate ..... 29

    4.7.5 Parity ..... 29

    4.7.6 Number of Bits ..... 30

4.8 Factory Reset ..... 30

4.9	Faults and Alarms .....	30
4.10	Proof Tests (SIL Only) .....	31
4.10.1	Test Solenoids .....	32
4.10.2	Test Relays .....	32
4.10.3	Test NAMUR .....	32
4.10.4	Test Alarms .....	33
4.10.5	Test 4-20 mA Out1 .....	33
4.10.6	Test 4-20 mA Out2 .....	33

**Chapter 5. Programming with Modbus**

5.1	About Menu .....	35
5.2	Login .....	35
5.2.1	Login as User .....	35
5.2.2	Login as Admin .....	35
5.2.3	Login as SIL User (SIL ONLY) .....	36
5.3	Change Password .....	36
5.4	Error Handler/Alarms .....	36

**Chapter 6. Calibration with HMI**

6.1	Test and Trim .....	37
6.1.1	Channel Select .....	37
6.1.2	Trim .....	37
6.1.3	Test .....	38
6.1.4	Discard Trim and Save Trim .....	38
6.2	Field Cal .....	38
6.2.1	Configure Cal .....	39
6.2.1.1	Field Cal Type .....	39
6.2.1.2	Field Cal Percent .....	39
6.2.1.3	Before Delay Time .....	40
6.2.1.4	After Delay Time .....	40
6.2.1.5	Max Total Drift .....	40
6.2.2	Perform Cal .....	40
6.2.3	Calibration Drifts .....	41
6.2.4	Clear Calibration .....	41
6.2.5	Hold Last Value .....	42
6.2.6	Save Calibration .....	42

**Chapter 7. Calibration with Modbus**

7.1	Test and Trim .....	43
7.2	Field Calibration .....	44

**Chapter 8. Specifications**

8.1	Functional .....	45
8.2	Performance .....	46
8.3	Physical .....	47

**Appendix A. Modbus Map**

**Appendix B. SIL Modbus Map**

**Appendix C. Error Codes**

**Appendix D. Menu Maps**

D.1	Dashboard & Main Menu .....	59
D.2	Measure Menu .....	59
D.3	Outputs Menu .....	60
D.4	Alarms Menu .....	61
D.5	Diagnose Menu .....	63
D.6	Config Menu .....	65
D.7	Cal Menu .....	67

---

D.8	About Menu .....	70
D.9	Login Menu .....	70

**Appendix E. CE Mark Compliance**

**Appendix F. Abbreviations**

**Appendix G. Typical Application Examples**

G.1	Blanketing Gases in Hydrocarbon Liquid Storage Tanks .....	75
	G.1.1 The Problem .....	75
	G.1.2 Equipment Used .....	75
	G.1.3 Basic Operating Procedure .....	76
	G.1.4 Previous Systems .....	76
G.2	Reactor Feed Gases in Formaldehyde Production .....	76
	G.2.1 The Problem .....	76
	G.2.2 Equipment Used .....	77
	G.2.3 Basic Operating Procedure .....	78
	G.2.4 Previous Systems .....	78

**Appendix H. Calibration Sheet**

[no content intended for this page]

# Chapter 1. Features and Capabilities

## 1.1 Introduction

This chapter introduces you to the features and capabilities of the Panametrics XMO2pro Thermoparamagnetic Oxygen Transmitter. The following specific topics are discussed:

- Description and basic features of the XMO2pro
- Product overview
- Theory of operation
- System description
- Overview of typical XMO2pro applications

**Note:** The XMO2pro technical specifications and ordering information can be found in Chapter 8, "Specifications"

## 1.2 Basic Features

The XMO2pro analyzer measures the oxygen concentration in the range of 0-100% in various gas mixtures and provides a digital output and also two 4-20 mA analog output signals proportional to the oxygen concentration. The microprocessor-based XMO2pro provides automatic oxygen signal compensation for background gas composition and/or pressure variations. In addition, the XMO2pro is equipped with real-time error detection, field calibration via the integrated HMI (keypad), and optional fast-response software.

The XMO2pro Transmitter offers several unique design features:

- Ultra-stable thermistors and a temperature-controlled and ambient-temperature-resistant measuring cell ensures excellent zero and span stability as well as high tolerance to fluctuations in the ambient temperature, up to 40°C. For special applications, a high temperature unit is available for operation at higher ambient temperatures, up to 55°C.
- The design of the measuring cell is resistant to visible (medium-sized) contamination and relatively tolerant of sample gas flow rate variations. As it has no moving parts, the XMO2pro performs reliably under the shock and vibration found in many industrial applications.
- The XMO2pro's unique "bridge-within-a-bridge" measurement circuit and microprocessor-based operation automatically compensate the oxygen signal for variations in the magnetic and thermal properties of the background gas that would otherwise cause measurement errors.
- At high oxygen concentrations, changes in atmospheric pressure have significant effects on the measured oxygen level. However, the XMO2pro provides automatic microprocessor-based atmospheric pressure compensation of the oxygen signal for these applications.
- The modular design of the XMO2pro allows the user to easily replace the measuring cell and the entire electronics with a precalibrated measuring cell in just a few minutes. After the short field calibration, the XMO2pro is ready for use again without having to remove the apparatus from the sample system.
- An integrated display with user accessible magnetic switch buttons.
- An additional 4-20 mA analog output is available, allowing the user to output a second, tighter range within the existing calibration range.

The XMO2pro transmitter, which is available in weatherproof and explosion-proof packaging, is designed to be installed as close as possible to the process sample point. It can be located up to 450 ft (150 m) from the control system, display, or recorder using standard Panametrics cables.

- An RS485/RS232 serial communications interface and a multilevel, menu-driven user program provide a convenient means for calibrating and programming the XMO2pro.
- Internal software algorithms along with user-programmed calibration data provide compensation of the oxygen signal for background gas composition, atmospheric pressure, or both.
- Panametrics proprietary fast-response software provides enhanced response times to track rapidly changing processes.
- Sophisticated error-checking software with user-programmable defaults and error limits detects abnormal measurement conditions.

- Adjustment of the 4-20 mA analog output zero and span values can be made via the magnetic buttons on the HMI (stylus required).
- A drift calibration routine provides automatic drift compensation for minor changes in the sensor calibration setting.
- Programmable recalibration is accomplished in the field on the apparatus itself, with no potentiometers to adjust.

### 1.3 Product Overview

As shown in *Figure 1* below, the XMO2pro is equipped with several external features designed to facilitate its operation, maintenance and usability.

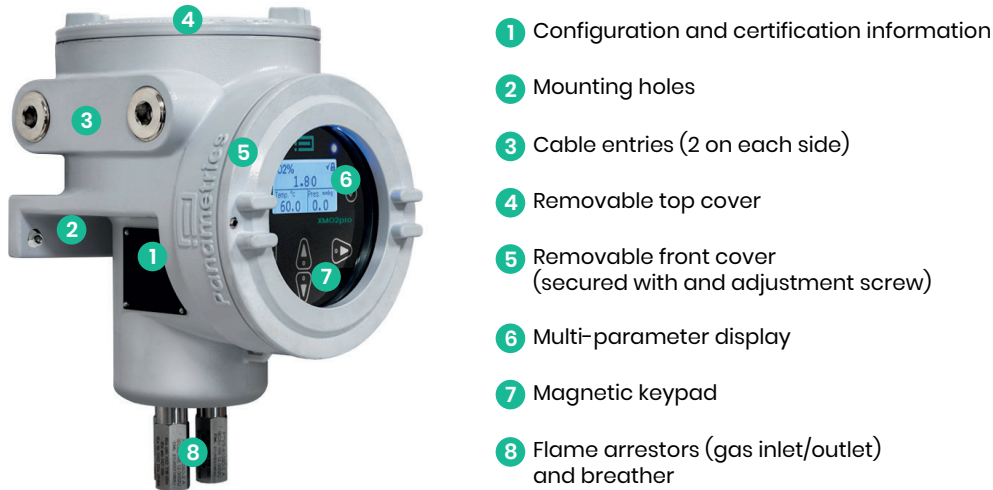

**Figure 1: External components of the XMO2pro**

### 1.4 Theory of Operation

The XMO2pro measures the concentration of oxygen in a gas mixture by utilizing the unique paramagnetic properties of oxygen.

As its magnetic susceptibility is approximately 100 times greater than that of most other common gases, oxygen can be easily differentiated from these gases based on its behavior in a magnetic field. Also, oxygen's magnetic susceptibility varies inversely with temperature. Therefore, by carefully combining a magnetic field gradient and a temperature gradient within the XMO2pro measuring cell, an oxygen-containing gas mixture can be made to flow along these gradients. This induced gas flow is known as a magnetic wind. The intensity of this magnetic wind depends on the concentration of oxygen in the gas mixture.

*Figure 2* below shows a flow schematic for the XMO2pro measuring cell. Permanent magnets within the cell create a magnetic field, while the cell temperature is controlled at an elevated temperature to maintain a stable, controlled, measurement environment. In addition, the cell contains two pairs of thermally-matched and highly stable, glass-coated thermistors. One thermistor of each pair located inside the magnetic field with the other thermistor of the pair located outside the field. The heated thermistors give rise to a temperature gradient within the magnetic field, part of the principle of operation of the apparatus.

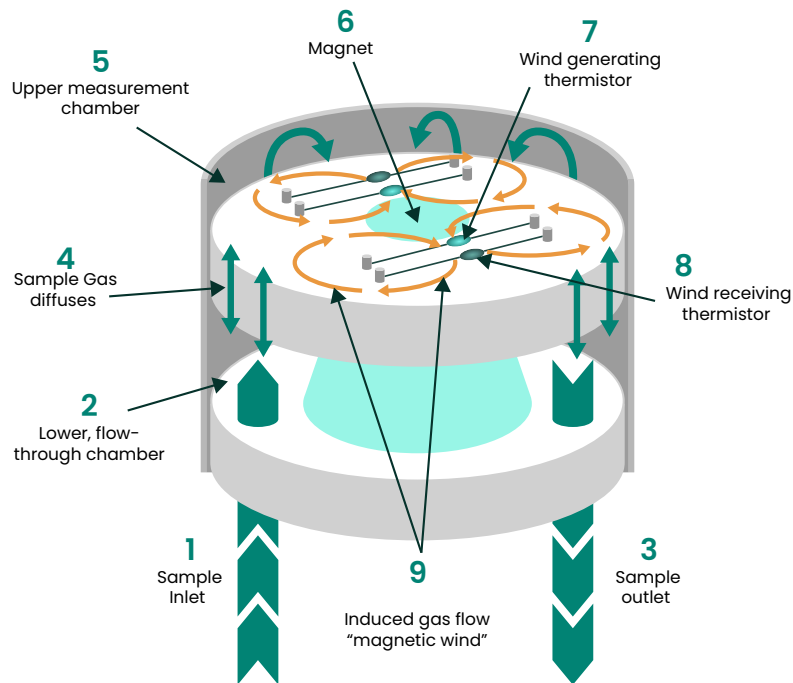

**Figure 2: Flow diagram of the XMO2pro measuring cell**

Sample gas continually flows through the lower flow-through chamber (1)(2)(3). This chamber acts as a pass-through and protects the sensor from contamination. A portion of the sample gas diffuses (4) into the upper chamber (5). The oxygen molecules are drawn into the center by the magnet (6) and leave across the heated matched thermistor pairs (7)(8) creating a “magnetic wind” (9). These thermistor pairs form part of a Wheatstone bridge, which generates a signal proportional to the oxygen concentration in the sample gas.

## 1.5 System Description

As an extractive industrial process oxygen analyzer, the XMO2pro requires the use of a sample conditioning system. This mandatory sample conditioning system may vary in design (required components) depending on process conditions. Panametrics offers complete solutions based on standard packages, but also designs and manufactures customized sample conditioning systems. Please contact Panametrics to find out what is required for a specific application.

The sample system is mandatory and can either be provided by Panametrics or constructed according to Panametrics’ recommendations.

### 1.5.1 The XMO2pro Transmitter

The XMO2pro transmitter is a self-contained apparatus, consisting of the oxygen sensor and associated electronics. It draws approximately 1.6-2.0A during warm-up, dropping to 300-500mA in normal operation. It provides a two self-powered 4-20mA analog outputs and a digital output signal that is proportional to the oxygen concentration of the sample gas and has fully programmable zero and span points. Also provided is an RS232/RS485 digital output for oxygen concentration, background gas, and atmospheric pressure signals. Programming, and calibration of the unit may also be performed via this interface. We recommend a power source capable of supplying up to 2.5A at 24+/-4 VDC.

The XMO2pro is designed to be installed in a sample system as close as possible to the process sample point. Thus, it is available in two environmental packages:

- Weatherproof
- Explosion-proof (with the addition of flame arrestors for the inlet and outlet)

The standard XMO2pro is configured for operation in an area with an ambient temperature up to 40°C. A high temperature XMO2pro is available for operation at higher ambient temperatures, up to 55°C (see “Ambient Operating Temperature Range” in *Chapter 8*).

Depending on the requirements of the installation site, the XMO2pro is available with an aluminum or stainless steel enclosure (see *Figure 3*).

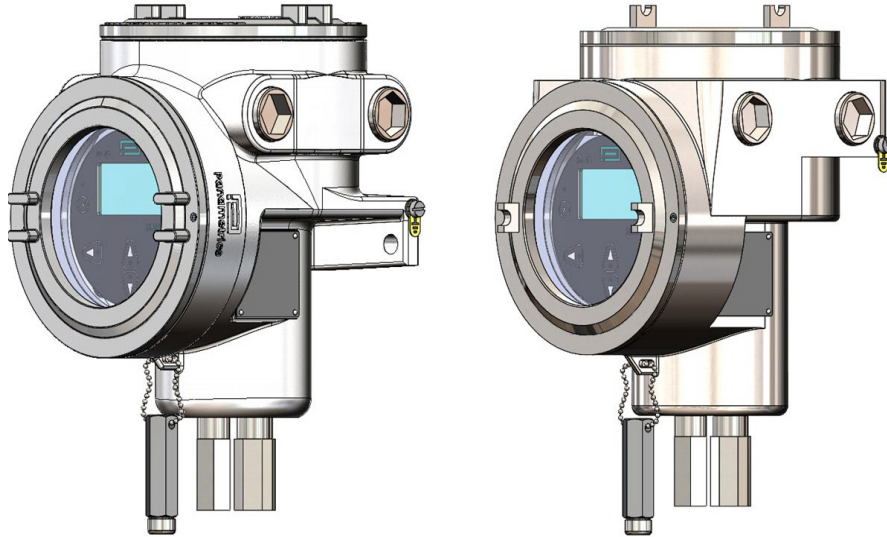
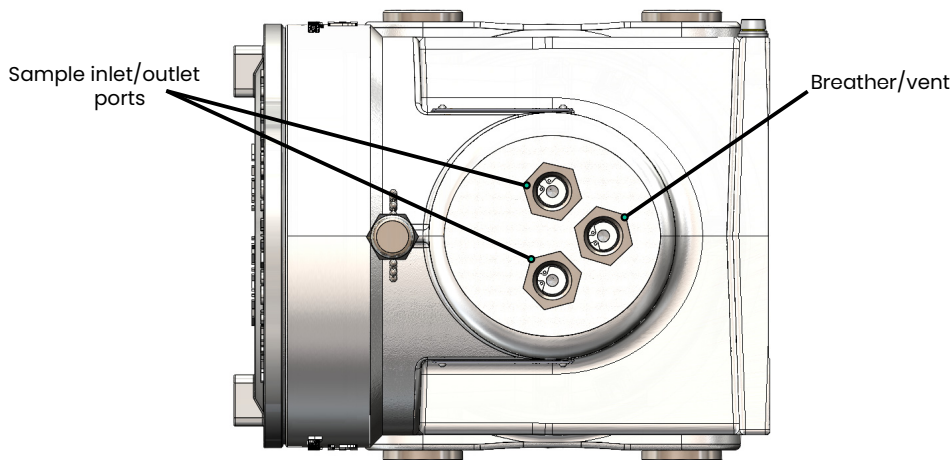

**Figure 3: Aluminum (left) and Stainless Steel (right) XMO2pro**

As shown in *Figure 4*, the XMO2pro has three ports: two interchangeable sample inlet and outlet ports and (for hazardous area units) a breather / vent fitting. The breather serves as a vent to avoid any potential accumulation of flammable gases inside the apparatus, allowing any such gases to diffuse safely out of the apparatus to the ambient before they can accumulate to a significant level (IEC 60079-1 requirement). It is permissible for the vented gas to disperse locally or to be piped to a dedicated vent in accordance with any site venting requirements.



**WARNING!** There shall be no restriction on the vent or any attached piping.



**Figure 4: XMO2pro Ports**

**IMPORTANT:** The XMO2pro transmitter can be configured for the following standard oxygen ranges:

0 to 1%	0 to 25%
0 to 2%	0 to 50%*
0 to 5%	0 to 100%*
0 to 10%	80 to 100%*
0 to 21%	90 to 100%*

\*Pressure compensation is required

The standard XMO2pro is configured for operation in an area with an ambient temperature up to 40°C. A high temperature XMO2pro is available for operation at higher ambient temperatures, up to 55°C, for special applications.

**Note:** *The higher operating temperature cell should only be selected only when necessary, as this results in reduced sensitivity.*

### 1.5.2 The Sample System

A sample system is mandatory for use with the XMO2pro transmitter. The specific design of the sample system depends on the conditions of the sample gas and the requirements of the application. At a minimum, the sample system shall include a sample gas flowmeter and a gas flow regulator valve/upstream flow limiting device.

In general, the sampling system must provide the XMO2pro transmitter with a clean (i.e. dust and moisture-free), representative sample of the sample gas at a temperature, pressure and flow rate that are within the limits listed in the technical specifications section of this manual (see *Chapter 8, "Specifications"*).

Panametrics offers sample systems for a wide variety of applications. A typical sample system for use with the XMO2pro transmitter is shown in *Chapter 2, "Installation"*. For assistance in designing your own sample system, please consult the factory.

Compliance to IEC 60079-1 requires:

- The maximum inlet pressure is 2 bar(g) / 0.2 MPa(g).
- The maximum inlet flow rate is 1.25 L/min (2.65 SCFH / 0.075m<sup>3</sup>/hr). An up-stream flow limiting device is required.

## 1.6 Applications

The stable and accurate thermoparamagnetic sensor, certified globally for use in hazardous area environments, make the XMO2pro the tool of choice for use in:

### Refinery & Petrochemical

- Blanketing gases in hydrocarbon storage
- Oxidation reactors
- Fertilizer processing urea production
- Terephthalic acid (PTA) production

### Metal Heat Treatment

- Monitoring of oxygen during various heat treatment processes of metals
- Aluminized steel

### **Biogas & Landfill**

- O<sub>2</sub> during anaerobic digestion to produce biogas
- O<sub>2</sub> to ensure process safety
- O<sub>2</sub> as a contamination after biogas processing
- O<sub>2</sub> in aerobic digesters during wastewater treatment

### **Nitrogen Generators**

- O<sub>2</sub> monitoring in Nitrogen generation

### **Pharmaceutical**

- Safety measurement in centrifuge for solid-liquid separation

### **Transportation**

- Maritime inert gas generators

Two typical use cases are described in more detail in the *Appendix G on page 75*.

## Chapter 2. Installation

### 2.1 Introduction

This chapter describes the installation of the XMO2pro transmitter and its sample conditioning system. It also contains information on connecting optional system components. Installing the XMO2pro sampling system consists of two basic steps:

1. Installing the XMO2pro transmitter in the sample system (if you purchased your sample system from Panametrics, this step has already been done for you).
2. Mounting, plumbing, and wiring the sample system.

### 2.2 Installing the XMO2pro Transmitter

**Note:** This section applies only if the XMO2pro transmitter has not already been installed in the sample system by Panametrics.

The sample system delivers a clean, representative gas sample to the XMO2pro at the proper temperature, pressure and flow rate. This usually means a clean, dry gas sample that is free of solid and liquid particulates and is delivered at atmospheric pressure, a temperature no greater than 40°C (104°F) or 55°C (131°F) for the optional cell, and a flow rate of approximately 500 cc/ min (1.0 SCFH). A typical sample system for the XMO2pro might include an inlet gas flow regulating needle valve, a sample gas flow meter, and a pressure gauge (see *Figure 5*).

**Note:** Because factory calibration of the XMO2pro is done at atmospheric pressure and at a flow rate of 1.0 SCFH, operation of the XMO2pro at other pressures and/or flow rates requires a field recalibration to ensure optimum accuracy.

To install the XMO2pro transmitter in the sample system, complete the following steps:

1. Select a location in the sample system that provides at least 230 mm (9 in) of clearance above the top cover of the XMO2pro for access to the interior of the transmitter.
2. Mount the XMO2pro transmitter in the sample system via its two mounting holes. Be sure that the transmitter is upright and is level to within  $\pm 15^\circ$ .
3. Use 1/4" stainless steel tubing to connect the sample system Inlet and outlet fittings to the corresponding XMO2pro ports.

### 2.3 Installing the Sample System

You can order a complete sample system from Panametrics that is mounted on a steel panel and includes the XMO2pro transmitter and all necessary components and plumbing. Panametrics also offers standard (off-the-shelf) sampling systems and designs customized sampling systems build to your exact specifications.

#### 2.3.1 A Basic System

*Figure 5* shows a basic sample system that has been designed for use with the XMO2pro transmitter.

The sample system shown in *Figure 5* on page 8 consists of a painted steel plate with the following components mounted on it:

- Needle valves (1) for sample, zero, and span gas flow regulation
- Ball valves (2) for flow selection
- The process tubing (3)
- XMO2pro analyzer (4)
- Sample gas outlet pressure gauge (5)
- Sample gas flowmeter (6)

As it is recommended to operate the XMO2pro at atmospheric pressure and also because the sample pressure cannot exceed 2 barg per the specific conditions of use (refer *Section 2.5, "Specific Conditions of Use"*), it is recommended to include a pressure regulator (7) to prevent over-pressurisation. Other components include a filter (8), coalescer, or a pump could be added if needed.

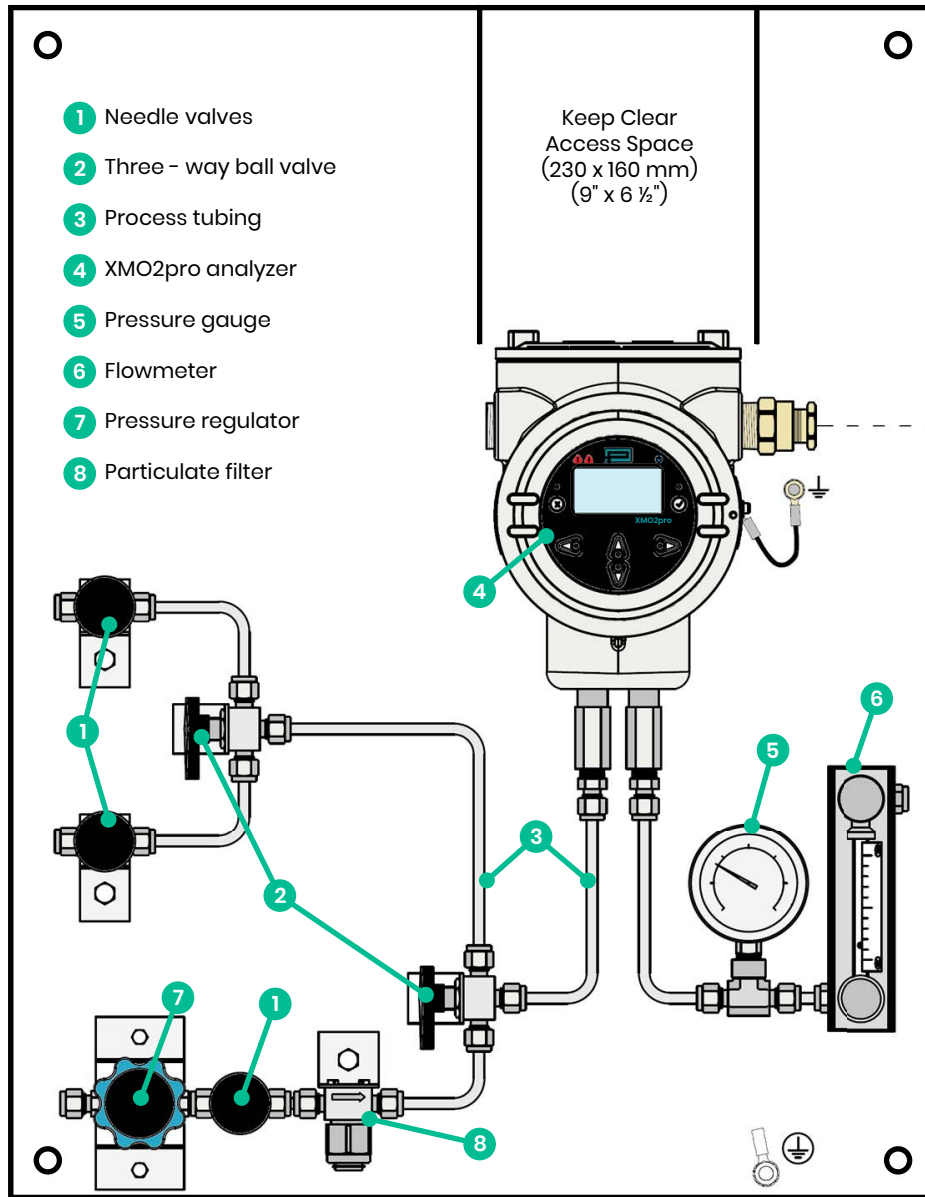

**Figure 5: Basic Sample System for XMO2pro**

### 2.3.2 Mounting the Sample System

To mount the sample system, complete the following steps:

1. Select a location that is as close as possible to the process sampling point. The ambient temperature at this location should be in the range of  $-20^{\circ}\text{C}$  to  $+40^{\circ}\text{C}$  ( $-4^{\circ}\text{F}$  to  $+104^{\circ}\text{F}$ ), for the standard cell.

**IMPORTANT:** For locations where the ambient temperature falls below  $-20^{\circ}\text{C}$  ( $-4^{\circ}\text{F}$ ), install the sample system in a heated enclosure.

2. Using the mounting holes provided, fasten the sample system to a convenient vertical surface. The system shall be installed in an orientation that keeps the XMO2pro transmitter upright and level to within  $\pm 15^{\circ}$ .
3. After the sample system has been mounted, use  $1/4"$  stainless steel tubing to connect all inlet and outlet lines to the  $1/4"$  tube fittings on the sample system. The sample line leading from the process to the sample system should be as short as possible in order to decrease system lag time and to prevent condensation in the line.

## 2.4 Wiring the Transmitter

**IMPORTANT:** Installation in hazardous locations shall be in accordance with these installation instructions and the National Electrical Code® ANSI/NFPA 70, the Canadian Electrical Code C22.1, or IEC/EN 60079-14, as applicable.

**IMPORTANT:** Ensure that the cable entry devices and plugs are IP66 and/or NEMA Type 4X rated as applicable.

### 2.4.1 Grounding the Apparatus



**WARNING!** The XMO2pro transmitter shall be properly grounded. Connect the external ground screw on the XMO2pro enclosure (see *Figure 6* below) to a suitable earth grounding point.

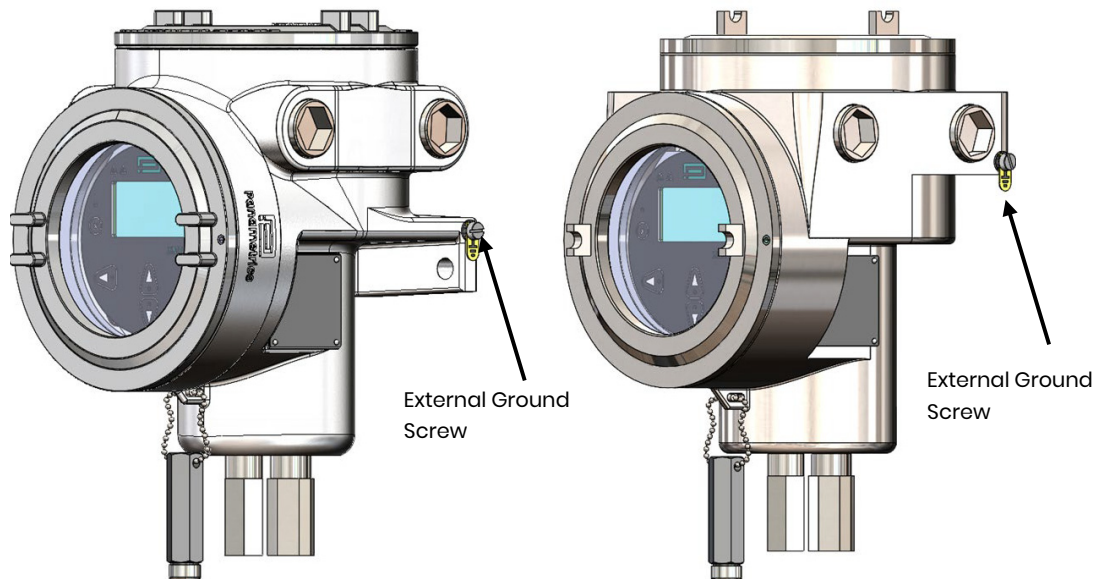

Figure 6: External ground screw locations for Aluminum and Stainless Steel versions of XMO2pro

### 2.4.2 Electromagnetic Compatibility (EMC) Performance Requirements



**WARNING!** To complete an EMC installation per IEC 61326-1 requirements, all electrical cables shall be installed as described in *Appendix E, "CE Mark Compliance" on page 71*.



**WARNING!** An EMC installation per IEC 61326-1 is required for apparatus installed in most countries around the world including, but not limited to, EU, EEA, EAC, Australia, New Zealand, Korea and India.



**WARNING!** Cable entries devices and/or plugs of an approved flameproof design are required. These must be installed according to the manufacturer's instructions the choice of cable entry device may limit the overall installation category achieved.

### 2.4.3 Cable Specifications

**PSU cable:** 2-core, shielded, twisted pair cable [TB1]{Port A}

**4-20mA Outputs cable:** 4-core, shielded, twisted pair cable [TB4]{Port B}

**Digital comms cable:** 3-core, shielded, RS-232/RS-485 cable [TB10]{Port C}

**Relay cables:** 12-core, shielded cable [TB2 & TB3] {Port D}

Refer to *Figure 7* for port location and *Table 1* for PSU cable length requirements:

**Table 1: Cable length requirements**

Maximum Cable Length		Wire Size	
ft	m	AWG	mm <sup>2</sup>
450	137	22	0.3
700	213	20	0.50
1050	320	18	0.8
1700	518	16	1.3
2800	853	14	2.00
4000	1219	12	3.3

#### 2.4.3.1 Accessing Terminal Blocks TB1, TB2, TB3, TB4, and TB10

The 24 VDC power input, 4-20 mA analog outputs, relay outputs and digital comms outputs wiring connections are made to terminal blocks TB1, TB2, TB3, TB4, and TB10 inside the XMO2pro (see *Figure 6*). To access this terminal block, loosen the locking screw and remove the cover. Then, refer to *Figure 7* for the location and pin designations of terminal blocks TB1, TB2, TB3, TB4, and TB10.



**CAUTION!** Do not make any connections to any unused pins on terminal blocks TB1, TB2, TB3, TB4, TB10, and TB11.

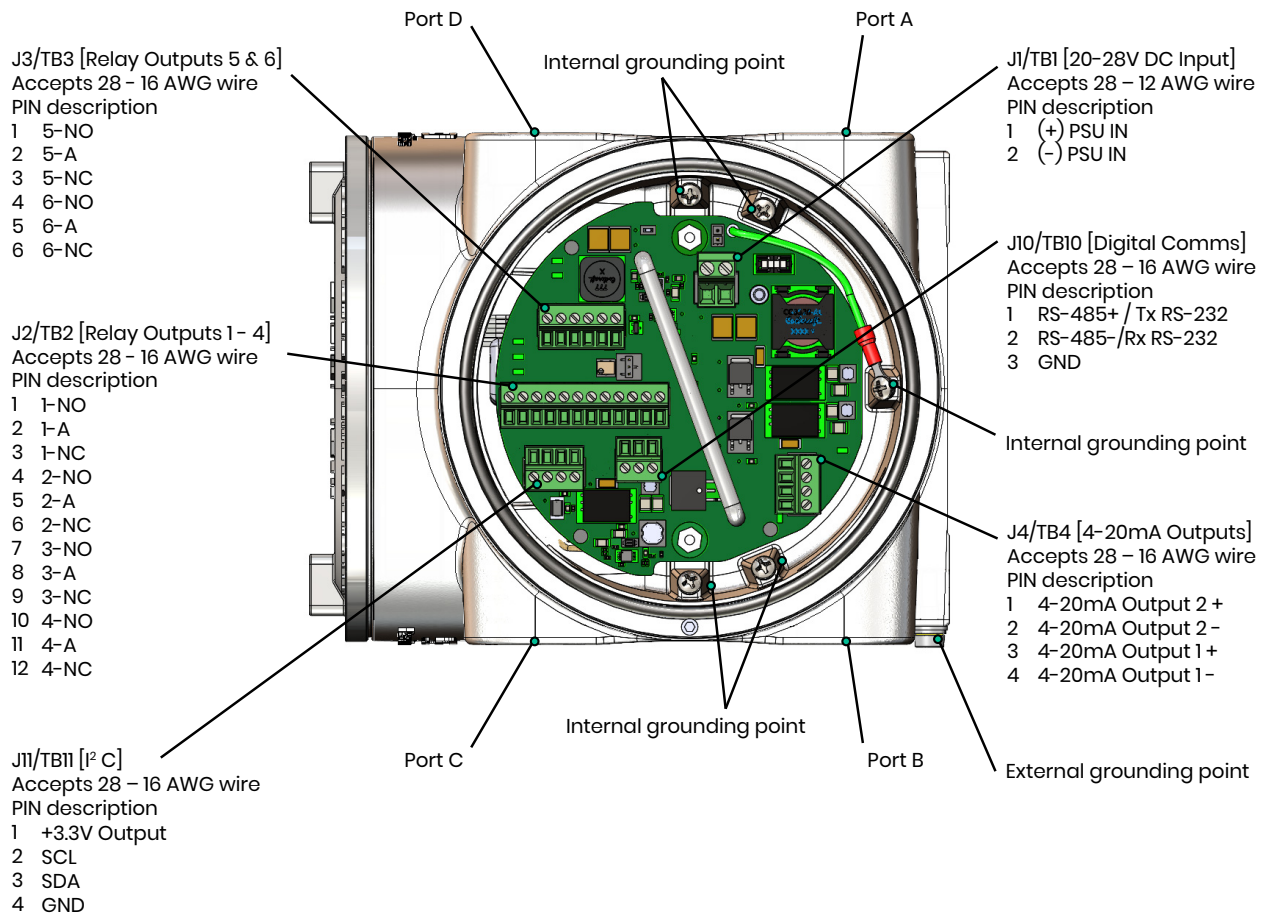

**Figure 7: Wiring Diagram**

### 2.4.4 Wiring the Power and Signal Connections

Complete the following steps to make the signal connections to the analyzer:

1. Install a cable clamp or gland in the 3/4" conduit hole.



**CAUTION!** All unused cable entries shall be sealed.



**CAUTION!** The 4-20mA outputs are internally-powered by the instrument. DO NOT apply any power supply source to any pin of J4/TB4

2. Route the associated cable through the cable clamp as described in Section 2.4.3, "Cable Specifications". Then, tighten the clamp to secure the cable.
3. Unplug the associated connector to this cable as outlined in Section 2.4.3, "Cable Specifications" by pulling them straight off the printed circuit board and loosen the screws on the side of the connectors.
4. Connect the appropriate leads per the wiring diagram in Figure 7.

Complete the following steps to safely finalize the wiring of the apparatus.



**CAUTION!** The positive supply shall only be connected via TB1-1. Connecting the +24 VDC supply to any other terminal will damage the XMO2pro. Such damage is not covered by our warranty.

1. Carefully plug the TB1, TB2, TB3, TB10 connectors back onto the printed circuit board, and reinstall the cover on the XMO2pro. Tighten the lid-securing setscrew.
2. Connect the other ends of the cables to the  $24 \pm 4$  VDC power supply, the 4-20 mA inputs of the display/control device, and the serial port of the computer or terminal (see the instruction manuals for those devices for details).

### 2.4.5 Wiring the Alarm Relays

Terminal block J2 contains connections for the alarm relays. To wire these alarms, complete the steps described below.

**Note:** A failsafe alarm is wired to the normally-closed (NC) contacts, while a non-failsafe alarm is wired to the normally-open (NO) contacts. Alarms LL, L and H are factory-configured as non-failsafe. Alarm HH is factory-configured as failsafe. Alternative configuration by the user is not possible.

1. **LL Alarm** (factory-configured as non-failsafe):
  - a. Connect pin #1 (NO) to the alarm device input.
  - b. Connect pin #2 (A) to the alarm device return.
2. **L Alarm** (factory-configured as non-failsafe):
  - a. Connect pin #4 (NO) to the alarm device input.
  - b. Connect pin #5 (A) to the alarm device return.
3. **H Alarm** (factory-configured as non-failsafe):
  - a. Connect pin #7 (NO) to the alarm device input.
  - b. Connect pin #8 (A) to the alarm device return.
4. **HH Alarm** (System Fault Alarm) (this alarm is factory-configured in failsafe mode)
  - a. Connect pin #11 (A) to the alarm device return.
  - b. Connect Pin #12 (NC) to the alarm device input.

## 2.5 Specific Conditions of Use

The XMO2pro has hazardous area certifications for multiple regions. Special conditions are required for safe operation. These are as follows:

- 1.** Do not open when an explosive environment is present.
- 2.** Do not block or restrict the enclosure vent (3rd flame arrestor).
- 3.** The maximum inlet pressure is 2 bar(g)/0.2 MPa(g).
- 4.** The maximum inlet flow rate is 2.67 L/min (5.65 SCFH). An up-stream flow limiting device is required.
- 5.** To avoid the risk of electrostatic-charging of the painted surface, the apparatus shall only be cleaned with a damp cloth. Guidance on protection against the risk of ignition due to electrostatic discharge can be found in documents such as IEC TS 60079-32-1, ANSI/UL 60079-32 & C22.2 No. 60079-32.
- 6.** The internal CR1632 battery should not need to be replaced during the lifetime of the XMO2pro. Should replacement be necessary, this shall only be performed by authorized service personnel. Only RENATA or Panasonic batteries are permitted for apparatus installed in hazardous areas.
- 7.** The apparatus cannot be repaired by the user. Specifically, the flameproof design was assessed with non-standard thread lengths and cemented joints; these cannot be repaired. Contact Panametrics service team for assistance.
- 8.** Connecting cables shall be mounted securely and protected from mechanical damage, pulling and twisting.
- 9.** Cable entry devices of a suitably certified flameproof design are required. These shall be installed according to the manufacturer's instructions.
- 10.** Unused entries shall be sealed using a suitably certified threaded plug.
- 11.** All threaded entries shall be wrench-tight, suggested minimum torque is 54 N.m / 40 lbf-ft.
- 12.** For Class I and Zone 1 installations under (US) NEC or (Canadian) CEC jurisdiction, seal all conduit entries within 18" of the apparatus.
- 13.** Modifications to the flameproof enclosure are not permitted.
- 14.** Only trained, competent personnel may install, operate, and maintain the apparatus.
- 15.** The product is an electrical apparatus and shall be installed in the hazardous area in accordance with the requirements of the issued certificate. The installation shall be carried out in accordance with all the appropriate international, national and local standard codes of practices and site regulations for flameproof apparatus and in accordance with the instructions contained in the manual. Access to the circuitry is not permitted during operation.

[no content intended for this page]

## Chapter 3. Startup and Operation

### 3.1 Introduction

This chapter provides instructions for starting up and operating the XMO2pro system. The following specific topics discussed:

- Powering up the XMO2pro
- Establishing Sample Flow
- Calibration of the analog output signal

If you have not already done so, read *Chapter 2, "Installation"* for details on mounting and wiring the XMO2pro transmitter, the sample system, and any other optional equipment.

### 3.2 Powering the Analyzer

The XMO2pro transmitter does not have a power switch. It begins its initialization process as soon as a connection to the 24 VDC power source is established. The output signals are inhibited until a stable internal operating temperature is established, typically under 30 minutes.

Because the standard XMO2pro measurement cell is controlled at an elevated temperature, allow at least 30 minutes for the unit to reach a stable operating temperature before relying on the measurement. During this time, you can establish a sample gas flow through the system, as described in the next section.



**CAUTION!** It is the responsibility of the user to ensure that all cable entry devices and covers are properly installed and securely-fitted prior to applying power to the XMO2pro. The lid-securing setscrew shall always be tightened when the lid is reinstalled.

### 3.3 Establishing a Sample Gas Flow

Usually, the XMO2pro transmitter is factory-calibrated at a sample gas flow rate of 500 cc/min (1.0 SCFH) and at atmospheric pressure. Unless otherwise specified on your XMO2pro calibration sheet (*see Appendix H, "Calibration Sheet"*), optional sample system tagging, or optional sample system instructions, your XMO2pro should be operated at atmospheric pressure and at the flow rate listed in *Table 2*.

**Note:** For optimum performance, operating the XMO2pro at conditions other than those used for the factory calibration requires that the unit be recalibrated at the actual field conditions.

To establish a flow of sample gas through the system, complete the following steps (*see Figure 5 on page 8* as an example):

1. Set the sample system ball valves to direct only the sample inlet stream to the inlet port of the XMO2pro transmitter.
2. Use the sample inlet needle valve to regulate the flow of sample gas until the flowmeter reads the same flow rate listed for your unit in *Table 2 on page 16*.
3. Read the resulting system pressure on the pressure gauge. Make sure that there are no unnecessary flow restrictions downstream of the sample system.

**IMPORTANT:** For atmospheric pressure-compensated units, the XMO2pro outlet port shall be vented directly to atmosphere with no downstream restrictions. All sample system components and other restrictions shall be upstream of the XMO2pro transmitter.

#### 4. Take a reading of the XMO2pro 4-20 mA analog output.

In some applications, pressure changes due to flow rate changes can cause noticeable errors in the oxygen measurement. In such cases, consider the following corrective measures:

- Reduce the flow rate to the minimum recommended value minimizes flow rate sensitivity. A bypass flow (speed loop) allows minimum flow through the XMO2pro yet maintains a fast transport of the sample gas to the XMO2pro.
- For the fastest transport, minimize the sample line length from the process.
- If you cannot shorten the sample line length, reduce the sample line pressure to less than 5 psig. Proceed to the next section to complete the initial XMO2pro startup.

**Table 2: Recommended sample gas flow rates**

XMO2pro Type	Flow Rate in cc/min (SCFH)
Weatherproof	500 ± 250 (1.0 ± 0.5)
Explosion-proof	500 ± 100 (1.0 ± 0.2)
Pressure-compensated	250 ± 50 (0.5 ± 0.5)

### 3.4 Analog Output Calibration Options

The XMO2pro 4-20 mA analog output has been calibrated at the factory for the oxygen range indicated on the XMO2 Calibration Sheet shipped with the unit (see *Appendix H, "Calibration Sheet"*). Upon initial startup, field verification and/or calibration of the 4-20 mA analog output is required. To perform this task, either of the following procedures may be used:

- Field Calibration through HMI
- Digital communication calibration

This section provides information on calibrating the XMO2pro in the field using either a one-gas (offset gas) method or a two-gas (zero gas and span gas) method. The following specific topics are discussed:

- Factory calibration procedures
- Updating the factory calibration
- Required calibration materials
- Getting the XMO2pro ready
- How to perform a one-gas (Offset Gas) or two-gas (Zero and Span Gas) calibration
- How to perform an IDM digital communication calibration

After the XMO2pro is in operation, field calibration is recommended at intervals of about 1-3 months, depending on the application.

### 3.5 Factory Calibration Procedures

Prior to shipment, your XMO2pro was calibrated at the factory for the %O<sub>2</sub> range specified at the time of purchase. The following standard %O<sub>2</sub> ranges are available:

- 0 to 1%
- 0 to 5%
- 0 to 21%
- 0 to 50%\*
- 80 to 100%\*
- 0 to 2%
- 0 to 10%
- 0 to 25%
- 0 to 100%\*
- 90 to 100%\*

\* Pressure compensation is required

In addition, your XMO2pro was calibrated at the factory for the compensation signal specified at the time of purchase. The following standard compensation signals are provided:

- Background Gas Compensation – the standard factory calibration uses N<sub>2</sub> and CO<sub>2</sub> as the background gases.
- Pressure Compensation – the standard factory calibration is for atmospheric pressure (700–800 mm of Hg).

**Note:** Compensation signals are available for special background gases and/or special pressure ranges. For availability, pricing, and delivery, please contact Panametrics.

### 3.6 Required Calibration Materials

To perform a field calibration the following materials are required:

- Offset gas – for a one gas %O<sub>2</sub> calibration.
- Zero gas – for a two gas %O<sub>2</sub> and/or 4–20mA output calibration.
- Span gas – for a two gas %O<sub>2</sub> and/or 4–20mA output calibration.

**Note:** Suggestions for suitable calibration gases are listed on the XMO2pro Calibration Data Sheet provided with the unit (See Appendix H, "Calibration Sheet" for example). The accuracy of the calibration will only be as good as the accuracy of the calibration gas(es) used.

- Panametrics XMO2pro Calibration Data Sheet.
- A sample system or individual components (e.g. flowmeter, needle valve, pressure gauge, etc.) for introducing the calibration gas(es) to the XMO2pro transmitter at the required pressure and flowrate. See Chapter 2, "Installation" for specific installation recommendations.
- A multi-meter or ammeter (for 4–20mA output calibration).



**WARNING! Avoid using explosive gas mixtures as your XMO2pro Calibration gases.**

[no content intended for this page]

## Chapter 4. Programming with HMI

The XMO2pro is factory-programmed and ready for immediate use. However, you can access its programming using the HMI or a Modbus client software through your PC.

### 4.1 The XMO2pro Keypad

Along with the 128 x 64, monochrome LCD, the XMO2pro analyzer includes a 6-key magnetic keypad (see *Figure 8*). The magnetic wand used to activate a magnetic key is found attached to the meter chassis below the front panel. An operator activates the key by pressing the magnetic wand up to the glass lid over the desired key. The LED will light indicating a successful key press.

**Note:** The pushbutton switch will also act as a key press but is done with the glass lid open. Do not use the pushbutton switch in a hazardous area where the lid needs to be installed.

Use the magnetic keypad to navigate through the user program. The menu map may be followed in sequence, or the four arrow keys may be used to scroll through the prompt screens.

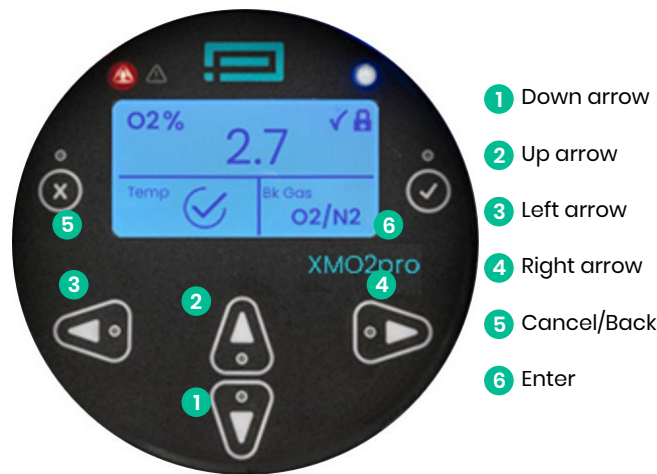

**Figure 8: Keypad layout**

**IMPORTANT:** The XMO2pro keypad enables programming of the instrument through the glass faceplate without removing the cover. Thus, all programming procedures may be performed while the unit is installed in a hazardous area.

Six keys on the keypad enable users to program the XMO2pro:

[✓] - Enter: confirms choice of a specific option and data entry within the option.

[✗] - Cancel/Back: allows users to cancel a selection and/or return to the previous option.

[▲] [▼] - up and down: enable users to navigate through the sub-menu after entering one of the main menu options (using the Enter key).

[◀] [▶] - left and right: enable users to scroll to a specific option, among choices in an option, or to a character in a text entry.

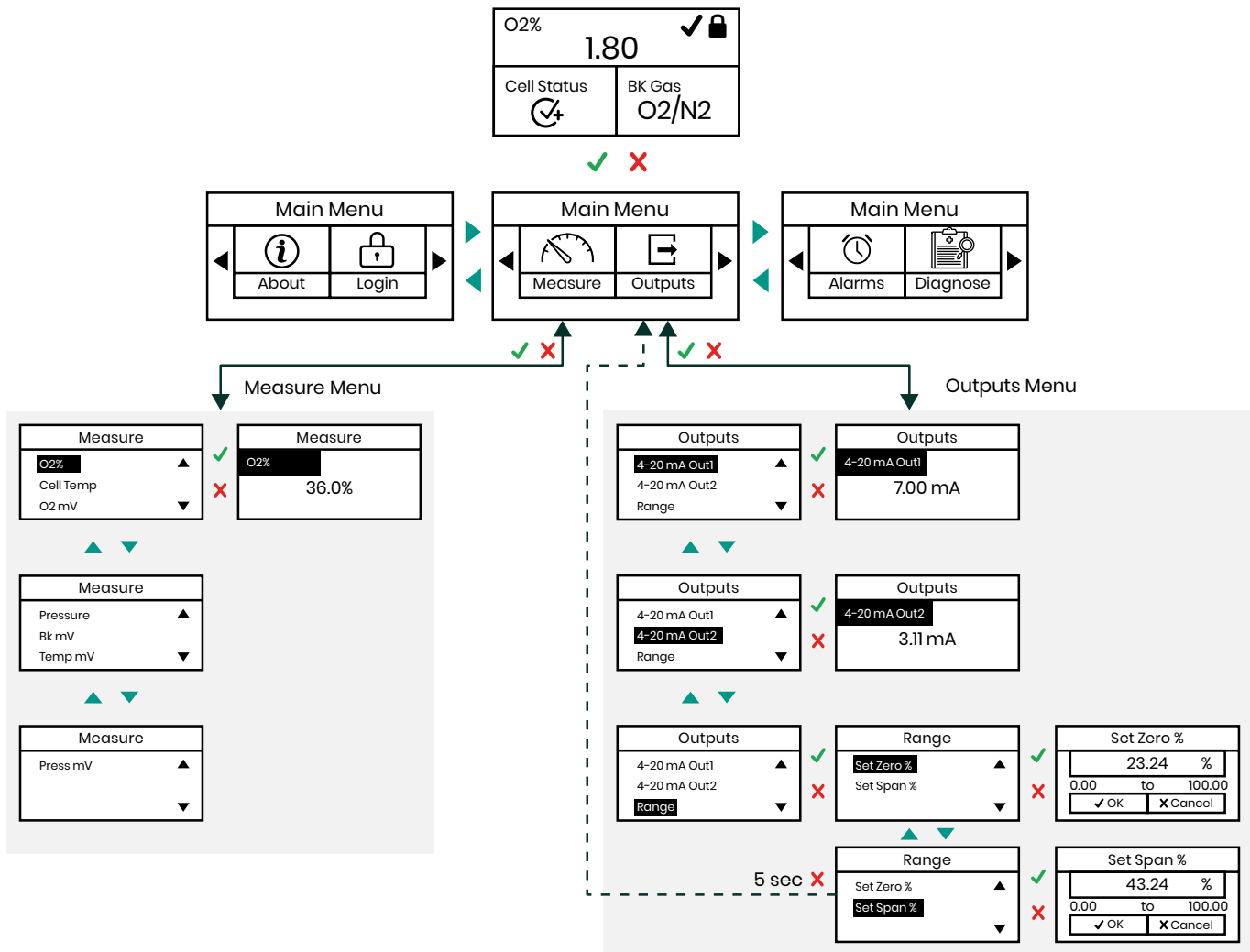

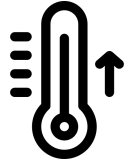
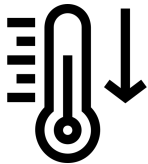

**Figure 9: Snapshot of the XMO2pro User Menu**

For a complete overview of the navigation options available for programming the XMO2pro, please refer to the full menu map located in *Appendix D, page 59*.

## 4.2 Dashboard

The XMO2pro dashboard screen provides real time monitoring of key parameters related to the gas analyzer performance. The following readings are displayed:

1. O<sub>2</sub> %: This shows the percentage of the signal gas in the gas mixture. It provides a direct measurement of the signal gas concentration
2. Cell Temp Status: Indicates the current status of the cell, which is critical for accurate measurements. The status may display as under temperature, over temperature and stable temperature using the following icons:

	Indicates the cell temperature is over the setpoint
	Indicates the cell temperature is under the setpoint
	Indicates the cell temperature is at the correct level

3. Background Gas Name: Displays the name of the background gas mixture.

## 4.3 About Menu

The “About” menu provides the user with the following information about the device:

1. Device Name
2. Serial Number
3. Part Number (configuration string)
4. Firmware Version
5. Safety Firmware Version
6. Boot Loader Version

About	
Device	▲
Part Nr	
Serial Nr	▼

About	
FW Version	▲
SFW Version	
BL Version	▼

## 4.4 Login Menu

The "Login" menu provides the operator with three functionalities:

1. Log on to the unit
2. Change the password for a User profile
3. Logout

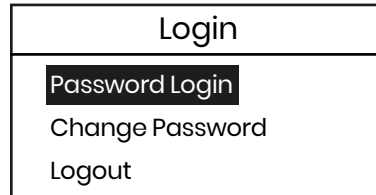

The unit comes configured with 3 different user access levels (see figure below). Each level defines the information the different users can access and edit, i. e., the different levels of read-only and read-write privileges. For instance, the User profile can only configure some device level parameters like the contrast but cannot configure a "Field Cal" whereas an Admin profile can configure a "Field Cal" but can also adjust the contrast level of the device. The following are the profile options available:

1. User
2. Admin
3. SIL User (only on SIL devices)

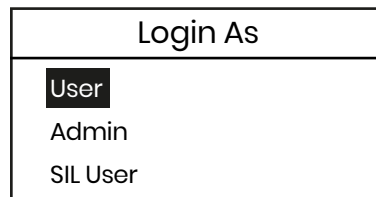

For every wrong password attempt a cooldown time is activated which starts at 3 seconds and doubles for every subsequent wrong password attempt. The cooldown time will reset after a successful password login.

Symbol	Key on Unit
U	Up Key
D	Down Key
L	Left Key
R	Right Key

**Note:** Logging in takes the meter offline and it enters configuration mode. When in configuration mode the meter will still send and receive digital signals and also output alarm relays but the primary 4-20mA output will read 3.8mA. You must log out to return to online mode and resume measurements.

### 4.4.1 Login as User

To log in as a user to the device, go to the logins menu and select "Login As". You will be provided with 3 options, select "User". Now the unit will prompt the password for that profile. Enter the password and press OK. If login is successful, you will be redirected to the dashboard screen and you will see an open padlock icon with the number 1 in it, indicating "USER" profile login. In the case the password is incorrect you will be prompted with a "Login Error" screen and will be redirected to the login screen.

**Note:** The default User profile password is "▲▲▲▲▲▲▲▲" (up key eight times). The customer can initially login in with this password and make use of the change password feature to set an alternate password. Customers are advised to change the default passwords upon initial commissioning. Refer to the local cyber security guidelines.

The diagram shows a rectangular box titled "User Login". Inside the box, there is a horizontal row of four navigation arrows: an upward-pointing triangle, a downward-pointing triangle, a rightward-pointing triangle, and a leftward-pointing triangle. Below this row is another horizontal row containing two buttons: the first button has a checkmark icon followed by the text "OK", and the second button has an 'X' icon followed by the text "Cancel".

### 4.4.2 Login as Admin

To log in as an admin to the device, go to the logins menu and select "Login As". You will be provided with 3 options, select "Admin". Now the unit will prompt the password for that profile. Enter the password and press OK. If login is successful, you will be redirected to the dashboard screen and you will see an open padlock icon with the number 2 in it, indicating "ADMIN" profile login.

**Note:** The default Admin profile password is "▲▼▲▼▲▼▲▼" (up and down keys four times). The user can initially login in with this password and make use of the change password feature to set an alternate password. Customers are advised to change the default passwords upon initial commissioning. Refer to the local cyber security guidelines.

The diagram shows a rectangular box titled "Admin Login". Inside the box, there is a horizontal row of four navigation arrows: an upward-pointing triangle, a downward-pointing triangle, a rightward-pointing triangle, and a leftward-pointing triangle. Below this row is another horizontal row containing two buttons: the first button has a checkmark icon followed by the text "OK", and the second button has an 'X' icon followed by the text "Cancel".

### 4.4.3 Login as SIL User (SIL ONLY)\*

The SIL User profile is a special access that enables proof tests on the unit. The SIL User login works differently than the other two profiles. To log in as SIL User refer to calibration sheet for password.

Enter the password and if password validation is successful, you will be redirected to the dashboard with an open padlock icon with the number 3 in it, indicating the "SIL USER" profile.

The diagram shows a rectangular box titled "SIL Login". Inside the box, there is a horizontal row of four navigation arrows: an upward-pointing triangle, a downward-pointing triangle, a rightward-pointing triangle, and a leftward-pointing triangle. Below this row is another horizontal row containing two buttons: the first button has a checkmark icon followed by the text "OK", and the second button has an 'X' icon followed by the text "Cancel".

\* Check the configuration string on the XMO2pro serial number label to confirm if the analyzer has the SIL option.

**Note:** The password for the SIL User profile can be found in the calibration datasheet.

#### 4.4.4 Change Password

The “Change Password” menu lets you change the password for the “USER” or “ADMIN” profile for the unit. To change the password for a specific profile you need to be logged in first. In case, you are not logged in and try to change the password you will be presented with a “LOGIN FIRST” error screen.

Once you are on the change password screen, you will be presented with two text boxes, where you enter the new password in the first text box and enter the new password again in the second text box to validate it. If both passwords match, then the password change is successful, and you will be redirected to the dashboard.

Change For	Change PWD: User
User ▲	▲▼▶◀
Admin ▼	▲▼▶◀
	✓ OK   ✗ Cancel

#### 4.5 Error Handling/Alarms

The “Alarms” menu allows you to configure the manner in which the XMO2pro responds to various error conditions. When you click on the Alarms menu option from the Main Menu a window like the figure below appears. Clicking on any option opens the window for that option.

Configure Alarms	
Analog Alarms ▲	
Digital Alarms	
Trip Points ▼	

There is an options/button in the above window for each of the following error conditions:

1. Watch Dog Error
2. Heater Error
3. ADC Error
4. DAC Error
5. MCU Error
6. Data Error
7. Brownout Error
8. Temperature Over
9. Temperature Under
10. Early Warning Under
11. Early Warning Over
12. Gas Over
13. Gas Under
14. Calibration Error
15. System Error

To configure the XMO2pro's response to any of the above error conditions, click on the corresponding button in the window above and proceed to the appropriate section for instructions.

**Table 3: Alarm relays and error conditions**

No.	Error	Default mA	Alarm Relays	Meaning														
1	Watchdog Err	21 mA	HH Alarm	Firmware is unresponsive														
2	Heat Err	21 mA	HH Alarm	Heater hardware fault detected														
3	ADC Err	21 mA	HH Alarm	Input hardware fault detected														
4	DAC Err	21 mA	HH Alarm	Output hardware fault detected														
5	MCU Err	21 mA	HH Alarm	Firmware has hard faulted														
6	Data Er	21 mA	HH Alarm	Unrecoverable data loss detected														
7	Brownout Err	3.6 mA	HH Alarm	Power supplied is not sufficient														
8	Temp Over	20.5 mA	H Alarm	Cell is too hot (normal during warmup)														
9	Temp Under	3.8 mA	H Alarm	Cell is warming up (normal during warmup)														
10	Early Over	20.5 mA	L Alarm	Gas% is below early low trip point														
11	Early Under	3.8 mA	L Alarm	Gas% is above early high trip point														
12	Gas Over	21 mA	Gas% is above alarm high trip point	13	Gas Under	3.6 mA	LL Alarm	Gas% is below alarm low trip point	14	Cal Err	21 mA	HH Alarm	Calibration corrections cannot be applied	15	Sys Error	21 mA	HH Alarm	System fault detected
13	Gas Under	3.6 mA	LL Alarm	Gas% is below alarm low trip point	14	Cal Err	21 mA	HH Alarm	Calibration corrections cannot be applied	15	Sys Error	21 mA	HH Alarm	System fault detected				
14	Cal Err	21 mA	HH Alarm	Calibration corrections cannot be applied	15	Sys Error	21 mA	HH Alarm	System fault detected									
15	Sys Error	21 mA	HH Alarm	System fault detected														

The early under, early over, gas under and gas over alarms are associated with trip points and will trigger when the gas% exceeds the specified trip point. See *Figure 10* to determine how Early low/high alarms and trip points function.

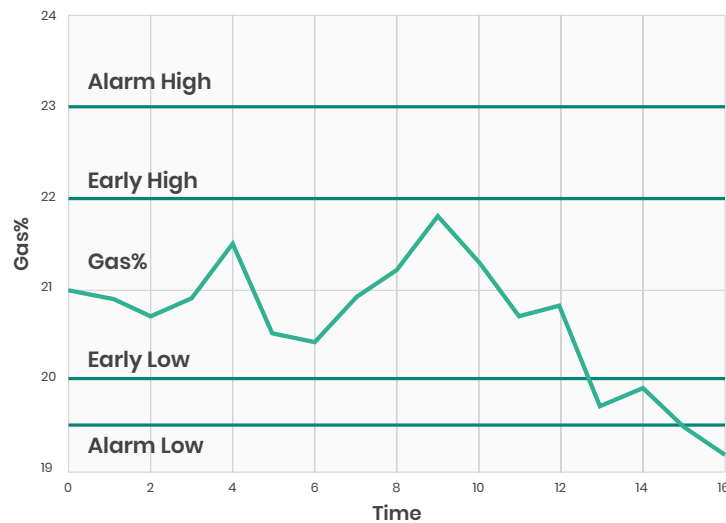

**Figure 10: Early low/high alarms and trip points function**

The “Analog Alarms” menu allows you to enable or disable error handling for the secondary 4-20 mA output for each specific error conditions for the XMO2pro. When you click on the alarms menu from the main menu a window as shown in the figure below opens. Clicking on any option opens the window for that option.

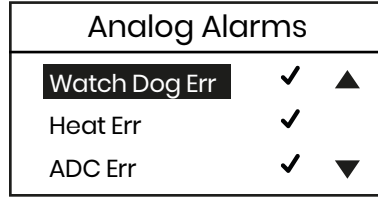

There is an options/button in the above window for each of the following error conditions listed in *Table 3*. To configure the XMO2pro’s response to any of the listed error conditions, click on the corresponding button in the window above and proceed to the appropriate section for instructions.

### 4.5.1 Analog Alarms

The “Analog Alarms” menu lets you enable or disable error handling for the secondary 4-20 mA output. The window is similar to the figure below. If you disable the alarm, it will not be signaled via the secondary 4-20 mA output.

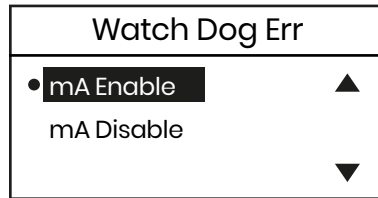

If you click on “mA Enable”, a window similar to the figure below opens.

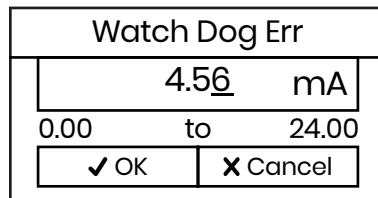

Enter the desired error mA output in the text box and click on enter to confirm the entry.

### 4.5.2 Digital Alarms

The “Digital Alarms” option lets you enable or disable error handling for alarm relays. The windows are similar to the figures below.

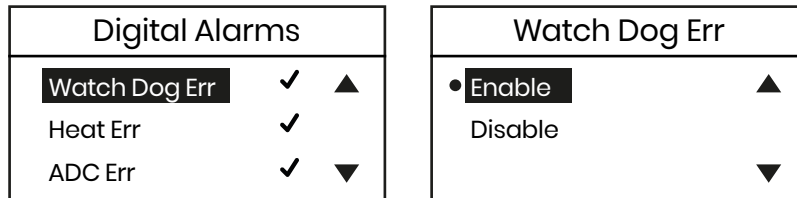

Once the error condition is selected, if you click on enable, the error condition will not be signaled via the alarm relays. You are then returned to the error handler window.

### 4.5.3 Trip Points

The "Trip Points" option lets you specify the gas% alarm trip points. The windows are similar to the figures below.

Alarms	
Alarm Low	▲
Alarm High	
Early Low	▼

Alarm High	
4.56	%
-20	to 120
✓ OK	✗ Cancel

If you click the trip points, the window displays a text box similar to that in the figure above. Enter the desired gas % beyond which the alarm should trip. Output in the text box and click on the next item/enter to confirm the entry. The gas % set is a threshold and if the unit exceeds that the alarm will be triggered. You are then returned to the error handler window.

## 4.6 Display Config

The "Display Config" menu gives the operator 4 options to customize the display. The menu can be found under the "Config" menu from the main menu.

1. Invert Display (invert the coloring scheme)
2. Contrast (adjust the contrast)
3. Language
4. Units (change unit system)

Display Config	
Invert Display	▲
Contrast	
Language	▼

### 4.6.1 Contrast Settings

To adjust the contrast settings of the LCD display, navigate to the "Config" menu and select "Display Config". Select "Contrast" and the below screen should appear:

Display Config	
Contrast	
<div style="display: flex; align-items: center;"> <div style="width: 100px; height: 20px; background: linear-gradient(to right, black 20%, white 20%);"></div> <span style="margin-left: 10px;">22</span> </div>	
<input type="button" value="✓ OK"/>	

Use the left/right arrow keys on the unit to decrement/increment the contrast of the LCD. When done press Enter.

## 4.6.2 Invert Display

The LCD has the capability to invert its colours from black to white and vice versa. To toggle between the 2 modes, select the "Invert Display" option from the "Display Config" menu and click OK.

Display Config	
Invert Display?	
✓ OK	✗ Cancel

## 4.6.3 Units

The feature enables customers to toggle between metric and imperial unit systems for parameter readings. For example: cell temperature in Celsius (metric) or Fahrenheit (imperial). By default, the unit system is metric, but the user has the flexibility to switch between the two-unit systems whenever desired.

Units	
• Metric	▲
Imperial	▼

## 4.7 Modbus Parameters

The "Modbus Parameters" provides the following configurable parameters to the operator:

1. Modbus Port
2. Modbus Slave ID
3. Baud Rate
4. Parity
5. # of bits
6. Stop Bits

Modbus Params	
Modbus Port	▲
Modbus Slave ID	▼
Baud Rate	▼

### 4.7.1 Mode

Enable or disable Modbus on the unit. When enabled Modbus parameters cannot be configured. To configure any of the following parameters, disable Modbus and change the desired parameter.

Modbus Mode	
Enable	▲
Disable	▼

### 4.7.2 Port

Modbus communications is available through 2 ports. You can select one of the following through the HMI:

1. RS232
2. RS485

Modbus Port	
• RS232	▲
RS485	▼

### 4.7.3 Slave ID

Modbus slave ID can be set using the Modbus parameters menu between 1 and 247.

Modbus Slave ID	
10	
0 to 247	
✓ OK	✗ Cancel

### 4.7.4 Baud Rate

The unit supports different baud rates for Modbus communications. You can select from the options below:

1. 9600
2. 14400
3. 19200
4. 68400
5. 57600
6. 115200

Modbus Params	
Baud Rate	
115200	

### 4.7.5 Parity

The unit supports three parity options for Modbus:

1. Odd
2. Even
3. None

Parity	
Odd	▲
Even	
• None	▼

### 4.7.6 Number of Bits

There are two options for stop bits:

1. 7 Bits
2. 8 Bits

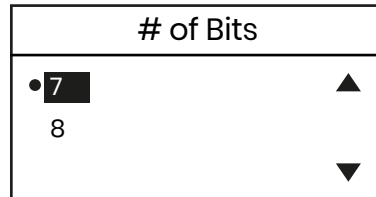

### 4.8 Factory Reset

The factory reset menu is available under the "Config" menu and gives the operator two options:

1. Restore Previous – Restores the previous settings for the device.
2. Restore Factory – Restore factory settings for the device.

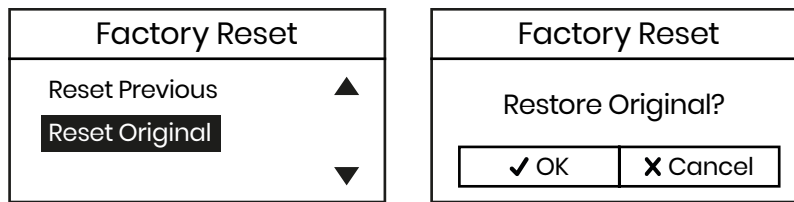

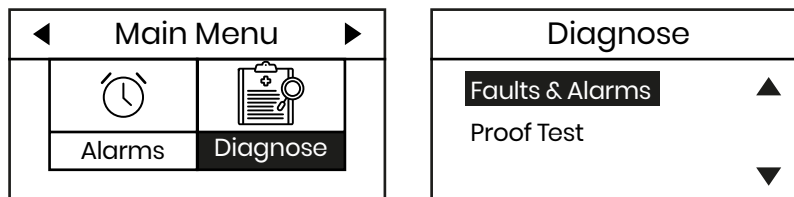

### 4.9 Faults and Alarms

The "Faults and Alarms" menu provides the operator with a summary of the alarms that are enabled, tripped, or disabled during device operation. The "Faults and Alarms" menu can be found under the "Diagnose" menu.



The following icons indicate the operation of alarms:

Icon	Operation
	Alarm Enabled
	Alarm Disabled
	Alarm Tripped

## 4.10 Proof Tests (SIL Only)

Proof tests allow you to stress test the device to maintain your SIL certification. The Proof tests menu can be found under the Diagnose Menu. The menu provides you with the following options:

1. Proof Test Mode
2. Test Solenoids
3. Test Relays
4. Test NAMUR
5. Test Alarms
6. Test CH1
7. Test CH2

To enable proof tests select "Proof Test Mode" and click enable.

Proof Tests	
Proof Test Mode	▲
Test Solenoids	
Test Relays	▼

Proof Tests	
• Enable	▲
Disable	▼

### 4.10.1 Test Solenoids

The menu provides you the option to test either both solenoids on the unit or test either one at a time. The menu provides four options to test solenoids:

1. SOL\_NONE
2. SOL 1
3. SOL 2
4. SOL BOTH

Proof Tests	
Proof Test Mode	▲
<b>Test Solenoids</b>	
Test Relays	▼

Test Solenoids	
<b>SOL NONE</b>	SOL 1
SOL 2	SOL BOTH

### 4.10.2 Test Relays

The menu provides you the option to test the relays on the unit. The menu provides four options to test the relays:

1. Relay LL (Low-Low)
2. Relay L (Low)
3. Relay H (High)
4. Relay HH (High-High)

Proof Tests	
Proof Test Mode	▲
Test Solenoids	
<b>Test Relays</b>	▼

Test Relays	
<b>Relay LL</b>	Relay L
Relay H	Relay HH

### 4.10.3 Test NAMUR

The menu provides you the option to test the NAMUR on the unit. The menu provides four options:

1. NAMUR LL (Low-Low)
2. NAMUR L (Low)
3. NUMAR H (High)
4. NAMUR HH (High-High)

Proof Test	
<b>Test NAMUR</b>	▲
Test Alarms	
Test 4-20 mA Outl	▼

Test Namur	
<b>NAMUR LL</b>	NAMUR L
NAMUR H	NAMUR HH

#### 4.10.4 Test Alarms

The menu provides you with an option to test all 15 alarms as mentioned in *Section 4.5*. Simply select the alarm you want to test and click enable.

Proof Test	
Test NAMUR ▲	
<b>Test Alarms</b>	
Test 4-20 mA Out1 ▼	

Test Alarms	
<b>Watch Dog Err</b> ▲	
Heat Err	
ADC Err ▼	

#### 4.10.5 Test 4-20 mA Out1

The option lets you test the 4-20 mA outputs for Channel 1. Enter the mA value you want to test for after selecting the "Test CH1" option from the "Proof Test" menu.

Proof Test	
<b>Test 4-20 mA Out1</b> ▲	
Test 4-20 mA Out2 ▼	

Test 4-20 mA Out1	
8.01 mA	
0.00 to 24.00	
✓ OK	✗ Cancel

#### 4.10.6 Test 4-20 mA Out2

The test is like the test for Channel 1 as mentioned in the section above.

Proof Test	
Test 4-20 mA Out1 ▲	
<b>Test 4-20 mA Out2</b> ▼	

Test 4-20 mA Out2	
03.60 mA	
0.00 to 24.00	
✓ OK	✗ Cancel

[no content intended for this page]

## Chapter 5. Programming with Modbus

The Modbus communications protocol allows you to read/write data and log/view real-time and diagnostic data in numeric formats.

**Note:** *Be sure you have properly installed Modbus Client Software on your PC before attempting to program the XMO2pro.*

### 5.1 About Menu

The About Menu provides the following information about the device:

1. Device Serial Number
2. Device Part Number
3. Device Firmware Version
4. Device Safety Firmware Version
5. Device Boot Loader Version

You can find the registers corresponding to these in the Modbus Map. These are read-only registers that can only be modified by Service(s).

### 5.2 Login

The XMO2pro comes configured with 3 profiles (below) and each profile has different levels of Read-Only and Read-Write privileges. For instance, the User profile can only configure some device level parameters like the contrast but cannot configure a “Field Cal” whereas an Admin profile can configure a “Field Cal” but can also adjust the contrast level of the device. The following are the profile options available:

Profile	USER_ID
User	1
Admin	2
SIL User	3

#### 5.2.1 Login as User

To log in as a user via Modbus write to the register USER\_ID and set ID as 1. Refer table above. Write the password to the register “PWD\_LOGIN”. If validation is successful, you will receive a status “OK” from the Modbus client.

**Note:** *The default User profile password is “7951”. The customer can initially login in with this password and make use of the change password feature to set an alternate password. Customers are advised to change the default passwords upon initial commissioning. Refer to the local cyber security guidelines.*

#### 5.2.2 Login as Admin

To log in as an admin over Modbus write to the register USER\_ID and set it to 2. Refer table above. Write the password to the register “PWD\_LOGIN”. If validation is successful, you will receive a status “OK” from the Modbus client.

**Note:** *The default Admin Profile password is “7852”. The customer can initially login in with this password and make use of the change password feature to set an alternate password. Customers are advised to change the default passwords upon initial commissioning. Refer to the local cyber security guidelines.*

### 5.2.3 Login as SIL User (SIL ONLY)

The SIL User profile is a special access that enables proof tests on the unit. The SIL User login works differently than the other two profiles. To log in as an SIL User do the following:

Once, you have the acquired password, write the password to register PWD\_LOGIN. If validation is successful, you will receive a status "OK" from the Modbus client. (Refer to *Appendix A, "Modbus Map"* on page 51 for register information).

**Note:** SIL profile login password for both HMI and Modbus will be available in the calibration certificate.

### 5.3 Change Password

To change the password of a certain User profile, ensure you are logged in using the respective profile. Post that, write the new desired password into the register PWD\_CHANGE. If the Modbus responds with an OK, the password has been changed successfully.

### 5.4 Error Handler/Alarms

The "Alarms" menu allows you to configure the way the XMO2pro responds to various error conditions. Refer to the Modbus Map below to access XMO2pro alarms.

To enable/disable an alarm you need to write to the ANALOG\_ALARMS\_EN register which is a bitmask to enable alarms. Once the alarm is enabled you can set the mA value of the alarm for it to trip.

There is a register in the map for each of the following error conditions:

Register	Alarm
ALARM_01_MA	Watch Dog Err
ALARM_02_MA	Heater Error
ALARM_03_MA	ADC Error
ALARM_04_MA	O2 DAC Error
ALARM_05_MA	MCU Error
ALARM_06_MA	Data Error
ALARM_07_MA	Brownout Error
ALARM_08_MA	Temperature Over
ALARM_09_MA	Temperature Under
ALARM_10_MA	Early Warning Under
ALARM_11_MA	Early Warning Over
ALARM_12_MA	Gas Over
ALARM_13_MA	Gas Under
ALARM_14_MA	Calibration Error
ALARM_15_MA	System Error

To program for all the XMO2pro error conditions listed above, write to the register corresponding to the alarm you want to program. Enter the mA output within the range provided in the Modbus Map that you wish to have generated in the event of an error.

## Chapter 6. Calibration with HMI

### 6.1 Test and Trim

The 4-20 mA output command enables you to recalibrate the output that the XMO2pro sends to an external device such as a recorder or digital multimeter. Selecting the Test and Trim menu will provide you with the following options:

The Trim function calibrates the 4-20 mA output signals by defining the zero and span points to preferred values. The Test function enables validation of the configuration by driving arbitrary values to the 4-20 output and applying the updated Trim configuration before saving it.

To execute a Trim, select the “Test and Trim” option under the “Cal” menu. It will show you the following options:

1. **Channel Select** – Determines which channel the Trim will be applied to.
2. **Trim** – Initiates the Trim function workflow.
3. **Test** – Assigns the value for testing the Trim setup.
4. **Discard Trim** – Discards the current Trim configuration.
5. **Save Trim** – Persists the current Trim configuration.

Test & Trim	
Channel Select	▲
Trim	
Test	▼

#### 6.1.1 Channel Select

Customer can switch between Channel 1 or Channel 2 to apply the Trim configuration.

Channel Select	
4-20 mA Out1	▲
● 4-20 mA Out2	
	▼

#### 6.1.2 Trim

Initiates the Trim workflow by requesting numerical inputs in the designated sequence for the following parameters:

1. **Set Zero mA** – Desired Zero Point.
2. **Set Measured Zero mA** – Measured Zero Point.
3. **Set Span mA** – Desired Span Point.
4. **Set Measured Span mA** – Measured Span Point.

After completing the workflow above, you will be redirected to the “Test” menu.

Set Zero mA	
21.40 mA	
0.00 to 24.00	
✓ OK	✗ Cancel

Measured Zero mA	
21.20 mA	
-48.00 to 48.00	
✓ OK	✗ Cancel

### 6.1.3 Test

Enabling test mode, activates the newly configured trim setting temporarily. It will prompt you to the enter a mA value which will be trimmed according to the new trim setting. You can verify the operation of the new trim value using a multimeter or recorder in Test Mode. If the signal is not satisfactory, you can delete the configuration using discard trim or save it, if it is satisfactory.

Test	
Set mA (Simulated)	▲
	▼

Simulated mA	
21.10	mA
0.00	to 24.00
✓ OK	✗ Cancel

### 6.1.4 Discard Trim and Save Trim

Discards/Saves the current Trim configuration.

Discard Trim?	
✓ OK	✗ Cancel

Save Trim?	
✓ OK	✗ Cancel

## 6.2 Field Cal

When you select the "Field Cal" option, a window similar to the one in the figure below opens:

Field Cal	
Configure Cal	▲
Perform Cal	
Calibration Drifts	▼

The "Field Cal" options offers the following 7 choices:

1. Configure Cal - Sets the calibration type and parameter.
2. Perform Cal - Calibrates the XMO2pro.
3. Calibration Drifts - Lists drift percentages for zero and span gases.
4. Hold Last Value - Holds the last value calibrated.
5. Abort Cal - Aborts the field calibration process.
6. Clear Cal - Clears the last calibration.
7. Save Cal - Saves current calibration to flash memory.

**Note:** Clicking on the Next Item/Enter button selects the option listed on the status line above the option buttons (Perform Cal in figure above). The option listed on the status line in any window is the option that was chosen the last time that menu was used.

Clicking on any of the “Field Cal” choices opens a new window that allows you to perform that function. Proceed to the appropriate section for a detailed description of each option.

### 6.2.1 Configure Cal

The “Configure Cal” option enables you to change the field calibration type and various calibration parameters. Clicking on the “Configure Cal” button opens a window like that shown in figure below:

Configure Cal	
Before Delay Time	▲
After Delay Time	▼
Max Total Drift	▼

Click on the desired option button and proceed to the appropriate section for a discussion of that option.

#### 6.2.1.1 Field Cal Type

A typical “Field Cal Type” window is shown in figure below:

Field Cal Type	
• 1 Point (Offset)	▲
2 Point (Zero/Span)	▼

**IMPORTANT:** The factory setting is the 2-point (Zero/Span) calibration type.

Click on the appropriate button to select the desired calibration type. Then, click on any button on the right to return to the “Configure Cal” window.

#### 6.2.1.2 Field Cal Percent

There are two field percent options available under the “Config Cal” menu:

1. Zero Field Cal
2. Span Field Cal

The above options are used to specify the oxygen percentages of the zero and span calibration gases that will be used (values should match the gas cylinder). The recommended gases are listed on the XMO2pro calibration datasheet. Click on the “Zero Field Cal” button to enter the percentage of oxygen in your zero gas. A window similar to the figure below opens.

Zero Field Cal %	
21.00	%
0.00	to 100.00
✓ OK	✗ Cancel

Type the zero-gas oxygen percentage in the text box, and click the Enter button to confirm the entry (click the Previous Item or Exit Page button to leave the window without changing the existing percentage)

**IMPORTANT:** The factory setting is for a 0.00% zero gas and a 20.93% span gas (air).

Repeat the above procedure to enter your span calibration gas oxygen percentage. Then, click on any button on the right to return to the “Configure Cal” window.

### 6.2.1.3 Before Delay Time

Clicking on the “Before Delay Time” button opens a window similar to the figure below. Entering a before delay time will set it for both zero and span calibration points.

Enter the desired zero/span point before delay time, in minutes and seconds, in the text box. Then, click on the Next Item/ Enter button to confirm the entry (click the Previous Item or Exit Page button to exit the window without changing the existing value).

Before Delay Time	
11:34	
MM:SS	
✓ OK	✗ Cancel

### 6.2.1.4 After Delay Time

Repeat the procedure in the above section to set the after-delay time for both the zero and span points.

After Delay Time	
11:34	
MM:SS	
✓ OK	✗ Cancel

### 6.2.1.5 Max Total Drift

“Max Total Drift” is the maximum total calibration drift allowable, expressed as a percentage of the full-scale reading. Selecting this option opens a window similar to the figure below:

Max Total Drift	
34.00	
-1000.00 to 1000.00	
✓ OK	✗ Cancel

Enter the desired percentage of the full-scale reading in the text box, and click the Next Item/Enter button to confirm the entry (click the Previous Item or Exit Page button to leave the window without changing the existing percentage).

## 6.2.2 Perform Cal

Clicking on the “Perform Cal” button opens a window similar to figure below:

Perform Cal	
Zero Field Cal	▲
Span Field Cal	▼

Click on the “Zero Field Cal” button to calibrate the zero point or on the “Span Field Cal” button to calibrate the span point. In either case, a window like the figure below opens.

Perform Cal: Zero Point	
Yes	▲
	▼

Click “Yes” to perform the calibration, or “Abort Field Cal” to stop the calibration and return to the previous menu. The result of a completed calibration is shown in figure below.

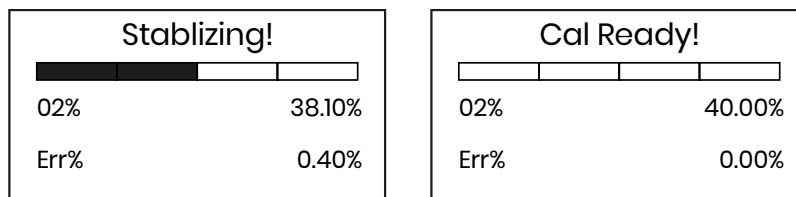

### 6.2.3 Calibration Drifts

The “Calibration Drifts” option enables you to view the current calibration drift at both the zero and span points since the last calibration was performed. Clicking on this button opens a window similar to the figure below.

Calibration Drifts		
	Zero	Span
Drift Prev.	21.22	3.00
Drift Fact.	54.78	67.00

Click on any button to return to the main “Field Cal” window.

### 6.2.4 Clear Calibration

The window for the “Clear Calibration” option is similar to figure below.

Field Cal	
Hold Last Value	▲
Abort Cal	
Clear Cal	▼

Click on the “Yes” button to clear the most recent calibration, or click on the “No”, “Previous Item” or “Exit Page” button to close the window without clearing the most recent calibration. If you click on the Yes button, a confirmation screen similar to the figure below opens.

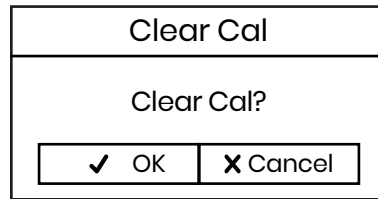

### 6.2.5 Hold Last Value

In addition to performing a field calibration or configuring the calibration parameters, you can program the XMO2pro to hold the last calibrated value. To perform this task, click on the “Hold Last Value” button. You will notice that the text on the button now reads “Disable Hold Last”. To cancel the Hold Last Value programming, just click on this new button. You can toggle between the two states for this parameter by clicking on this button (remember that the current state is the one NOT written on the button)

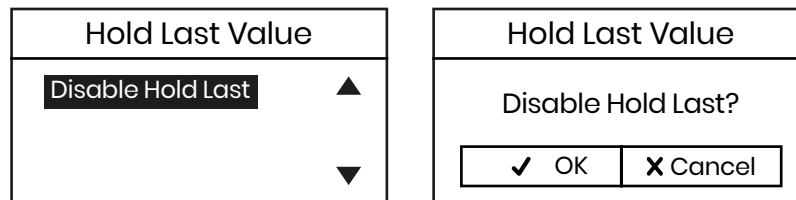

### 6.2.6 Save Calibration

The window for the “Save Calibration” option is similar to the figure below

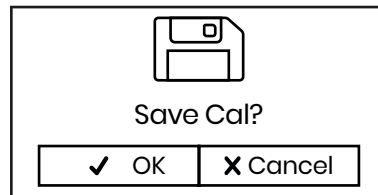

Clicking OK, will save the current calibration and persist to flash memory. If the save operation is successful, you will see a notification screen as the figure below.



Else, if the operation fails, you would see a screen as the figure below.

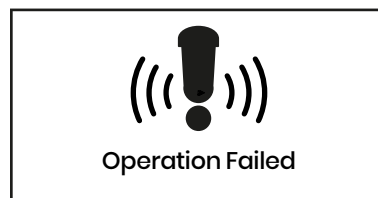

## Chapter 7. Calibration with Modbus

### 7.1 Test and Trim

The Trim procedure can be configured over Modbus as follows:

- 1.** TRIM\_CH – Channel Select (Ch 1 or Ch 2) to apply the Trim configuration.
- 2.** TRIM\_MA – Enter the desired mA value.
- 3.** TRIM\_MEASURED – Enter the measured mA value.
- 4.** TRIM\_SAVE –
  - a.** Write 0 to discard Trim.
  - b.** Write 1 to persist Trim.
  - c.** Write 4 to save the Trim point for 4 mA.
  - d.** Write 20 to save the Trim point for 20 mA.
  - e.** Write 12 to activate Verify Mode.

The workflow will be as follows:

- 1.** Select the desired Channel by writing to TRIM\_CH.
- 2.** Enter the desired 4 mA point in TRIM\_MA.
- 3.** Enter the measured mA for the 4-mA point in TRIM\_MEASURED
- 4.** Save the 4-mA point by writing 4 to TRIM\_SAVE.
- 5.** Enter the desired 20 mA point in TRIM\_MA.
- 6.** Enter the measured mA for the 20-mA point in TRIM\_MEASURED.
- 7.** Save the 20-mA point by writing 20 to TRIM\_SAVE.
- 8.** Enter verify mode by writing 12 to TRIM\_SAVE.
- 9.** Now, test the new Trim configuration by writing test values in TRIM\_MA and validate them.
- 10.** If you are satisfied with the Trim configuration enter 1 to TRIM\_SAVE.
- 11.** To discard it, write 0 to TRIM\_SAVE.

## 7.2 Field Calibration

The “Field Cal” for the unit can be done via Modbus as follows.

The “Configure Cal” option enables you to change the field calibration type and various calibration parameters. To configure a cal over Modbus, do the following:

1. CAL\_CONFIG – Select the cal type (1 Point or 2 Point).
2. CAL\_SOLENOIDS – Select the solenoid for the Cal.

**Note:** *Solenoids refers to solenoid valves which are either user supplied or supplied as part of a sample system. These solenoid valves can be activated manually through Modbus to energize / de-energize to supply zero and span gases to the apparatus during a field calibration. This option is not currently available through the display.*

3. CAL\_ZERO – Specify the oxygen percentages of the zero gas.
4. CAL\_SPAN – Specify the oxygen percentages of the span gas.
5. CAL\_SAVE –
  - a. Write 1 to record zero gas.
  - b. Write 2 to record span gas.
  - c. Write 3 to go into Verify Mode.
  - d. Write 4 to persist data to flash.
6. Once, you save the cal, the field calibration process will start and you should see the gas % reading stabilize in the GAS\_PC\_STABILITY register.

## Chapter 8. Specifications

### 8.1 Functional

<b>Analog Output</b>	Two 4 to 20 mA isolated, 550 $\Omega$ maximum load, field-programmable
<b>Digital I/O</b>	RS232/RS485, 3-conductor
<b>Recommended Power Source</b>	2.5 A at 24.0 VDC $\pm$ 4 VDC
<b>Power Requirement (Typical)</b>	1.6-2.0 A during warm-up, dropping to 300-400 mA in stable operation with no alarms tripped, subject to ambient conditions and process gases
<b>Storage Temperature</b>	-20°C to +65°C (-4°F to 149°F)
<b>Ambient Operating Temperature</b>	Standard: -20°C to +40°C (-4°F to +104°F) High: -5 to 55°C (23 to 131°F)
<b>Sample Gas Pressure Range</b>	Max 2 barg (29 psig)
<b>Sample Gas Flow Range</b>	Max 1.25 L/min (2.65 SCFH)
<b>Keypad</b>	Magnetic, through the glass, keypad
<b>Display</b>	Backlit liquid crystal display
<b>Relay outputs</b>	<ul style="list-style-type: none"><li>• Contact ratings: 2 A, 28 VDC</li><li>• SPDT, Non-latching, fail-safe</li></ul>

## 8.2 Performance

<b>Accuracy</b>	<p>±1% of span</p> <p>±2% of span for 0 to 1% range</p> <p>±0.2% O<sub>2</sub> range for 90 to 100% and 80 to 100%</p>
<b>Linearity</b>	±0.5% of span
<b>Repeatability</b>	±0.2% of span
<b>Measurement Resolution</b>	0.01 mA
<b>Stability Zero</b>	±1.0% of span per month (±2% of 0–1% O <sub>2</sub> range)
<b>Span</b>	±0.4% of span per month (±0.8% for 0–1% O <sub>2</sub> range)
<b>Response Time, 90% Step Change</b>	<p>Fast 15 seconds</p> <p>EN50104 45 seconds</p> <p>Standard 70 seconds</p>
<b>Measurement ranges (typical)</b>	<p>0–1%</p> <p>0–2%</p> <p>0–5%</p> <p>0–10%</p> <p>0–21%</p> <p>0–25%</p> <p>0–50%*</p> <p>0–100%*</p> <p>80–100%*</p> <p>90–100%*</p> <p>*Pressure compensation required</p> <p>Consult factory for other optional ranges</p>
<b>Atmospheric Pressure Effect</b>	<p>Standard: ±0.2% of span per mm of Hg</p> <p>Optional: Pressure compensation</p>
<b>Required Sample Gas Flow Rate</b>	<p>Range: 0.1 to 2.0 SCFH (50 to 1,000 cc/min)</p> <p>Nominal: 1.0 SCFH (500 cc/min) nominal</p>
<b>Sample Gas Flow Rate Effect</b>	<1% of span, with weatherproof apparatus with background gas compensation, and 0.1–2.0 SCFH (50–1,000 cc/min) flow rate
<b>Warmup Time</b>	30 minutes

## 8.3 Physical

<b>Sensor Wetted Materials</b>	Standard: 316 SS process-wetted fittings, glass, and Viton™ internal O-ring seals Optional: Hastelloy processed-wetted fittings or Chemraz™ internal O-ring seals
<b>Dimensions</b>	Weatherproof unit: (H x D x W) 228 x 178 x 142 mm (9 x 7 x 6 in.) Explosion-proof unit: (H x D x W) 252 x 178 x 142 mm (10 x 7 x 6 in.)
<b>Weight</b>	Aluminum version: 4.5 kg (9.9 lb) Stainless Steel version: 11.0 kg (24.2 lb)
<b>Connections</b>	Electrical: 4 x ¾ in. NPTF conduit entries Process: 2 x 1/4 in. NPTF inlet and outlet

## Environmental

### Ingress Protection / Weatherproof rating

- IP66
- NEMA Type 4X

### Hazardous Area classification

#### IECEX, ATEX

- Ex db IIC T6 Gb  
Ex tb IIIC T78°C Db  
-20°C to +55°C

#### NEC/CEC

- XP Class I Division 1 Groups ABCD T6  
-20°C to +55°C
- DIP Class II Division 1 Groups EFG, Class III T6  
-20°C to +55°C
- Class I Zone 1 AEx/Ex db IIC T6 Gb  
-20°C to +55°C
- Class I Zone 21 AEx/Ex tb IIIC T78°C Db  
-20°C to +55°C
- NI Division 2 Class I, II, III Division 2 Groups ABCDEFG T6  
-20°C to +55°C
- NI Division 2 Class I, II, III Division 2 Groups ABCDEFG T6  
-20°C to +55°C

#### Ordinary locations, NEC/CEC

- UL 61010-1  
-20°C to +55°C

#### European Union Compliance

- EMC Directive 2014/30/EU  
Group 1, Class A, Industrial Electromagnetic Environments  
(IEC EN 61326-1 / CISPR 11)
- ATEX 2014/34/EU  
II 2 G & II 2 D

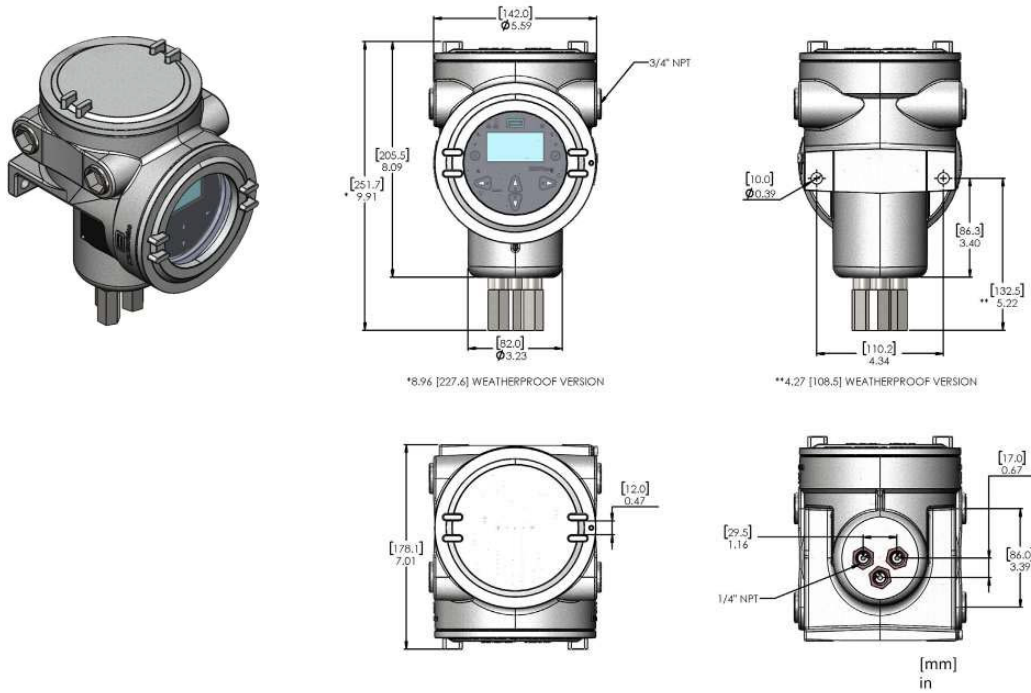

Figure 11: Aluminum Version Dimensions

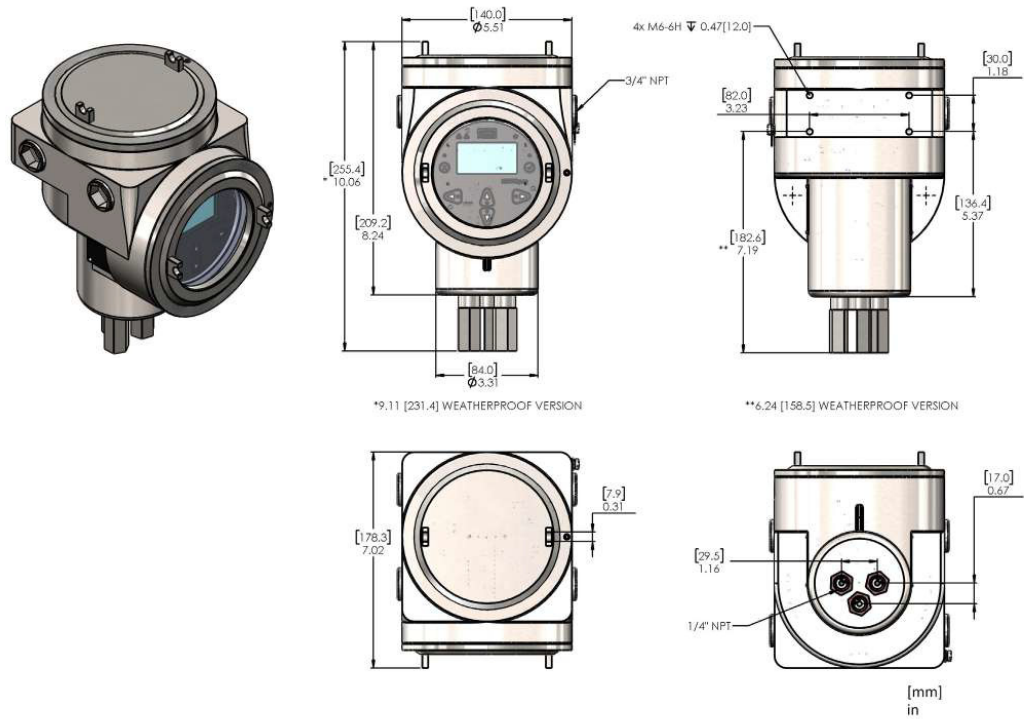

Figure 12: Stainless Steel Version Dimensions

[no content intended for this page]

## Appendix A. Modbus Map

ADDRESS	NAME	TYPE	ACCESS	COMMENT
40000(DEC) 9C40(HEX)	RUNNING_TIME	U32	RO (Admin) RO (User)	Seconds since power on / reset
40002(DEC) 9C42(HEX)	MODBUS_ID	U16	RW (Admin) RW (User)	Modbus device identifier
40003(DEC) 9C43(HEX)	STATUS	U16	RO (Admin) RO (User)	3 digit codes
40004(DEC) 9C44(HEX)	PRODUCT	U16	RO (Admin) RO (User)	Identifies the product model
40005(DEC) 9C45(HEX)	ALARM_STATES	U16	RO (Admin) RO (User)	Flags which indicate alarm is active
40006(DEC) 9C46(HEX)	UNITS	U16	RW (Admin) RW (User)	Unit systems
40007(DEC) 9C47(HEX)	CH1_GAS_PC	F32	RO (Admin) RO (User)	Primary gas %
40009(DEC) 9C49(HEX)	CH2_GAS_PC	F32	RO (Admin) RO (User)	User customized gas %
40011(DEC) 9C4B(HEX)	BK_GAS_PC	F32	RO (Admin) RO (User)	Background binary gas mixture %
40013(DEC) 9C4D(HEX)	GAS_PC_STABILITY	F32	RO (Admin) RO (User)	Stability of the gas % reading
40015(DEC) 9C4F(HEX)	CELL_TEMP_SETPOINT	F32	RO (Admin) RO (User)	Target cell temperature
40017(DEC) 9C51(HEX)	CELL_TEMP	F32	RO (Admin) RO (User)	Cell temp reading
40019(DEC) 9C53(HEX)	CELL_TEMP_STABILITY	F32	RO (Admin) RO (User)	Stability of the cell temperature
40021(DEC) 9C55(HEX)	AMBIENT_TEMP	F32	RO (Admin) RO (User)	Ambient temp reading
40023(DEC) 9C57(HEX)	AMBIENT_PRESS	F32	RO (Admin) RO (User)	Atmospheric pressure
40025(DEC) 9C59(HEX)	PROCESS_PRESS	F32	RO (Admin) RO (User)	Process pressure
40027(DEC) 9C5B(HEX)	CELL_O2MV	F32	RO (Admin) RO (User)	Bridge voltage
40029(DEC) 9C5D(HEX)	CELL_BKMV	F32	RO (Admin) RO (User)	Bridge voltage
40031(DEC) 9C5F(HEX)	CELL_PRMV	F32	RO (Admin) RO (User)	Pressure voltage
40033(DEC) 9C61(HEX)	CELL_PWRMV	F32	RO (Admin) RO (User)	Power supply
40035(DEC) 9C63(HEX)	CELL_TEMPMV	F32	RO (Admin) RO (User)	Cell temp sensor
40037(DEC) 9C65(HEX)	AMBIENT_TEMPMV	F32	RO (Admin) RO (User)	Ambient temp sensor
40039(DEC) 9C67(HEX)	POWER_VDC	F32	RW (Admin) RO (User)	20-28VDC Power supply (24VDC Nominal)
40041(DEC) 9C69(HEX)	DATE_YY	U16	RW (Admin) RO (User)	Year

ADDRESS	NAME	TYPE	ACCESS	COMMENT
40042(DEC) 9C6A(HEX)	DATE_MM	U16	RW (Admin) RO (User)	Month
40043(DEC) 9C6B(HEX)	DATE_DD	U16	RW (Admin) RO (User)	Day of month
40044(DEC) 9C6C(HEX)	DATE_WK	U16	RW (Admin) RO (User)	Weekday
40045(DEC) 9C6D(HEX)	TIME_HH	U16	RW (Admin) RO (User)	Hours
40046(DEC) 9C6E(HEX)	TIME_MM	U16	RW (Admin) RO (User)	Minutes
40047(DEC) 9C6F(HEX)	TIME_SS	U16	RW (Admin) RO (User)	Seconds
40048(DEC) 9C70(HEX)	CH1_RANGE_ZERO	F32	RO (Admin) RO (User)	Primary Channel gas % lower limit
40050(DEC) 9C72(HEX)	CH1_RANGE_SPAN	F32	RO (Admin) RO (User)	Primary Channel gas % upper limit
40052(DEC) 9C74(HEX)	CH2_RANGE_ZERO	F32	RW (Admin) RO (User)	Secondary Channel gas % lower limit
40054(DEC) 9C76(HEX)	CH2_RANGE_SPAN	F32	RW (Admin) RO (User)	Secondary Channel gas % upper limit
40056(DEC) 9C78(HEX)	TRIM_CH	U16	RW (Admin) RO (User)	Set channel for test and trim
40057(DEC) 9C79(HEX)	TRIM_MA	F32	RW (Admin) RO (User)	Set mA output to a known value
40059(DEC) 9C7B(HEX)	TRIM_MEASURED	F32	RW (Admin) RO (User)	Enter the value measured with a multi-meter
40061(DEC) 9C7D(HEX)	TRIM_SAVE	U16	RW (Admin) RO (User)	Discard/Record/Persist test trim readings
40062(DEC) 9C7E(HEX)	CAL_CONFIG	U16	RW (Admin) RO (User)	Select a calibration type
40063(DEC) 9C7F(HEX)	CAL_SOLENOIDS	U16	RW (Admin) RO (User)	Remote operation of the calibration relays
40064(DEC) 9C80(HEX)	CAL_ZERO	F32	RW (Admin) RO (User)	Enter % from zero calibration gas
40066(DEC) 9C82(HEX)	CAL_SPAN	F32	RW (Admin) RO (User)	Enter % from span calibration gas
40068(DEC) 9C84(HEX)	CAL_SAVE	U16	RW (Admin) RO (User)	Save Field Cal data
40069(DEC) 9C85(HEX)	DRIFT_INDEX	U16	RW (Admin) RO (User)	Index into drift history
40070(DEC) 9C86(HEX)	DRIFT_TIMESTAMP	U32	RO (Admin) RO (User)	Time at which drift data was captured
40072(DEC) 9C88(HEX)	DRIFT_ZERO	F32	RO (Admin) RO (User)	Total drift from factory at zero point
40074(DEC) 9C8A(HEX)	DRIFT_SPAN	F32	RO (Admin) RO (User)	Total drift from factory at span point
40089(DEC) 9C99(HEX)	GAS_CONFIG	U16	RO (User) RO (Admin)	Configure gas
40090(DEC) 9C99(HEX)	GAS_IDX_BK	U16	RO (User) RO (Admin)	Gas background mixture index

ADDRESS	NAME	TYPE	ACCESS	COMMENT
40092(DEC) 9C9C(HEX)	GAS_IDX_PT	U16	RO (User) RO (Admin)	Gas point on curve
40093(DEC) 9C9D(HEX)	GAS_O2_PC	F32	RO (User) RO (Admin)	Specifies the signal gas%
40097(DEC) 9CA1(HEX)	GAS_O2_MV	F32	RO (User) RO (Admin)	-
40099 (DEC) 9CA3 (HEX)	GAS_BK_MV	F32	RO (User) RO (Admin)	-
40103 (DEC) 9CA7 (HEX)	GAS_TEMP_MV	F32	RO (User) RO (Admin)	-
40105(DEC) 9CA9(HEX)	DIGITAL_ALARMS_EN	U16	RW (Admin) RO (User)	Bitmask to enable digital alarms
40106(DEC) 9CAA(HEX)	ANALOG_ALARMS_EN	U16	RW (Admin) RO (User)	Bitmask to enable analog alarms
40107(DEC) 9CAB(HEX)	ALARM_LOW_PC	F32	RW (Admin) RO (User)	Lower limit of the signal gas %
40109(DEC) 9CAD(HEX)	ALARM_HIGH_PC	F32	RW (Admin) RO (User)	Upper limit of the signal gas %
40111(DEC) 9CAF(HEX)	ALARM_01_MA	F32	RW (Admin) RO (User)	NAMUR mA level for alarm 01
40113(DEC) 9CB1(HEX)	ALARM_02_MA	F32	RW (Admin) RO (User)	NAMUR mA level for alarm 02
40115(DEC) 9CB3(HEX)	ALARM_03_MA	F32	RW (Admin) RO (User)	NAMUR mA level for alarm 03
40117(DEC) 9CB5(HEX)	ALARM_04_MA	F32	RW (Admin) RO (User)	NAMUR mA level for alarm 04
40119(DEC) 9CB7(HEX)	ALARM_05_MA	F32	RW (Admin) RO (User)	NAMUR mA level for alarm 05
40121(DEC) 9CB9(HEX)	ALARM_06_MA	F32	RW (Admin) RO (User)	NAMUR mA level for alarm 06
40123(DEC) 9CBB(HEX)	ALARM_07_MA	F32	RW (Admin) RO (User)	NAMUR mA level for alarm 07
40125(DEC) 9CBD(HEX)	ALARM_08_MA	F32	RW (Admin) RO (User)	NAMUR mA level for alarm 08
40127(DEC) 9CBF(HEX)	ALARM_09_MA	F32	RW (Admin) RO (User)	NAMUR mA level for alarm 09
40129(DEC) 9CC1(HEX)	ALARM_10_MA	F32	RW (Admin) RO (User)	NAMUR mA level for alarm 10
40131(DEC) 9CC3(HEX)	ALARM_11_MA	F32	RW (Admin) RO (User)	NAMUR mA level for alarm 11
40133(DEC) 9CC5(HEX)	ALARM_12_MA	F32	RW (Admin) RO (User)	NAMUR mA level for alarm 12
40135(DEC) 9CC7(HEX)	ALARM_13_MA	F32	RW (Admin) RO (User)	NAMUR mA level for alarm 13
40137(DEC) 9CC9(HEX)	ALARM_14_MA	F32	RW (Admin) RO (User)	NAMUR mA level for alarm 14
40139(DEC) 9CCB(HEX)	ALARM_15_MA	F32	RW (Admin) RO (User)	NAMUR mA level for alarm 15
40141(DEC) 9CCD(HEX)	ALARM_16_MA	F32	RW (Admin) RO (User)	NAMUR mA level for alarm 16

ADDRESS	NAME	TYPE	ACCESS	COMMENT
40143(DEC) 9CCF(HEX)	ALARM_SAVE	U16	RW (Admin) RO (User)	Save alarm config
40170(DEC) 9CEA(HEX)	GAS_NAME	S16	RO(User) RO(Admin)	Name of gas
40178(DEC) 9CF2(HEX)	SAVE_CONFIG	U16	RO(User) RO(Admin)	Saves all config changes
40179(DEC) 9CF3(HEX)	SERIAL_NO	S16	RO(User) RO(Admin)	Serial number
40197(DEC) 9CFB(HEX)	PART_NO	S16	RO(User) RO(Admin)	Part number
40195(DEC) 9D03(HEX)	FIRMWARE_VERSION	F32	RO(User) RO(Admin)	Application software version
40197(DEC) 9D05(HEX)	SAFETY_FW_VERSION	F32	RO(User) RO(Admin)	Safety critical software version
40199(DEC) 9D07(HEX)	BOOTLOADER_VERSION	F32	RO(User) RO(Admin)	Bootloader software version
40201(DEC) 9D09(HEX)	USER_ID	U16	RW (User) RW (Admin)	User profile
40202(DEC) 9D0A(HEX)	PWD_LOGIN	U64	WO (User) WO (Admin)	Password entry for login
40206(DEC) 9D0E(HEX)	PWD_CHANGE	U64	WO (User) WO (Admin)	Change password for logged-in profile
40210(DEC) 9D12(HEX)	PWD_RESET	U16	RO (User) RW (Admin)	Admin can reset any User profile password
40211(DEC) 9D13(HEX)	REBOOT	U16	RO (User) RW (Admin)	Reboot the system
40212(DEC) 9D14(HEX)	FACTORY_RESET	U16	RO (User) RW (Admin)	Restore factory or restore previous
40201(DEC) 9D09(HEX)	USER_ID	U16	RW (User) RW (Admin)	User profile
40202(DEC) 9D0A(HEX)	PWD_LOGIN	U64	WO (User) WO (Admin)	Password entry for login
40206(DEC) 9D0E(HEX)	PWD_CHANGE	U64	WO (User) WO (Admin)	Change password for logged-in profile
40210(DEC) 9D12(HEX)	PWD_RESET	U16	RO (User) RW (Admin)	Admin can reset any User profile password
40211(DEC) 9D13(HEX)	REBOOT	U16	RO (User) RW (Admin)	Reboot the system
40212(DEC) 9D14(HEX)	FACTORY_RESET	U16	RO (User) RW (Admin)	Restore Factory or Restore Previous
40153(DEC) 9CD9(HEX)	SOLENOIDS	U16	RW (Admin) RO (User)	Remote operation of the calibration relays

## Appendix B. SIL Modbus Map

ADDRESS	NAME	TYPE	ACCESS	COMMENT
40144(DEC) 9CD0(HEX)	PROOF_TEST	U16	RW (SIL) RO (Admin) RO (User)	Perform a proof test
40145(DEC) 9CD1(HEX)	TEST_SOLENOIDS	U16	RW (SIL) RO (Admin) RO (User)	Remote operation of the calibration relays
40146(DEC) 9CD2(HEX)	TEST_RELAYS	U16	RW (SIL) RO (Admin) RO (User)	Test alarm relays
40147(DEC) 9CD3(HEX)	TEST_NAMUR	U16	RW (SIL) RO (Admin) RO (User)	Test analog NAMUR levels
40148(DEC) 9CD4(HEX)	TEST_ALARMS	U16	RW (SIL) RO (Admin) RO (User)	Test a specified alarm
40149(DEC) 9CD5(HEX)	TEST_MV	U16	RW (SIL) RO (Admin) RO (User)	Simulates input mVs
40150(DEC) 9CD6(HEX)	TEST_CH1	F32	RW (SIL) RO (Admin) RO (User)	Test analog output 1
40152(DEC) 9CD8(HEX)	TEST_CH2	F32	RW (SIL) RO (Admin) RO (User)	Test analog output 2
40154(DEC) 9CDA(HEX)	TEST_O2MV	F32	RW (SIL) RO (Admin) RO (User)	Inject a simulated GasMV reading
40156(DEC) 9CDC(HEX)	TEST_BKMV	F32	RW (SIL) RO (Admin) RO (User)	Inject a simulated BKMV reading
40160(DEC) 9CE0(HEX)	TOLERANCE	F3	RW (SIL) RO (Admin) RO (User)	

[no content intended for this page]

## Appendix C. Error Codes

S.No	Code	Error/Warning
1	112	ERR: NMI Fault
2	211	ERR: MEM Fault
3	113	ERR: BUS Fault
4	122	ERR: USAGE FAULT
5	131	ERR: SVC Fault
6	212	ERR: DBGMON Fault
7	221	ERR: OS Fault
8	311	ERR: No Init
9	114	ERR: SIF Timeout
10	123	ERR: No Watchdog
11	132	ERR: SIF Lost
12	141	ERR: No Temp. Control
13	213	ERR: No Comp
14	222	ERR: No BK Comp
15	231	ERR: No PR Comp
16	312	ERR: No PRBK Comp
17	321	ERR: No Fast Response
18	411	ERR: No Drift Comp
19	115	ERR: No Trim CH1
20	124	ERR: No Trim CH2
21	133	ERR: No H2G
22	142	ERR: Brownout
23	232	ERR: UART Lost
24	241	ERR: RAM Lost
25	313	ERR: ROM Lost
26	322	ERR: MPU Lost
27	331	ERR: DAC Lost
28	412	ERR: ADC Lost
29	421	ERR: PWM Lost
30	511	ERR: Flash Lost
31	116	ERR: IOX Lost
32	125	ERR: LCD Lost
33	134	ERR: ECC Error
34	143	ERR: ADC CRC Error
35	332	ERR: Not Found
36	341	ERR: Invalid Argument
37	413	ERR: CRC Error
38	422	ERR: Access Denied
39	431	ERR: Type Mismatch
40	512	ERR: Under Range

S.No	Code	Error/Warning
41	521	ERR: Over Range
42	611	ERR: Out of Memory
43	117	ERR: Incomplete
44	126	ERR: No Connection
45	234	WRN: Not yet Saved
46	243	WRN: Warmup
47	333	WRN: Cal Reminder
48	414	ERR: Password Generation
49	343	WRN: Offline
50	146	WRN: No Clock
51	245	ERR: Busy
52	237	ERR: LCD Main Menu Cursor
53	246	ERR: LCD Cursor Generation
54	149	WRN: CRC Error
55	158	WRN: No Modbus
56	167	WRN: Modbus No Register
57	176	WRN: Modbus No Command
58	185	WRN: Modbus Idle
59	194	WRN: Modbus Type Error

# Appendix D. Menu Maps

## D.1 Dashboard & Main Menu

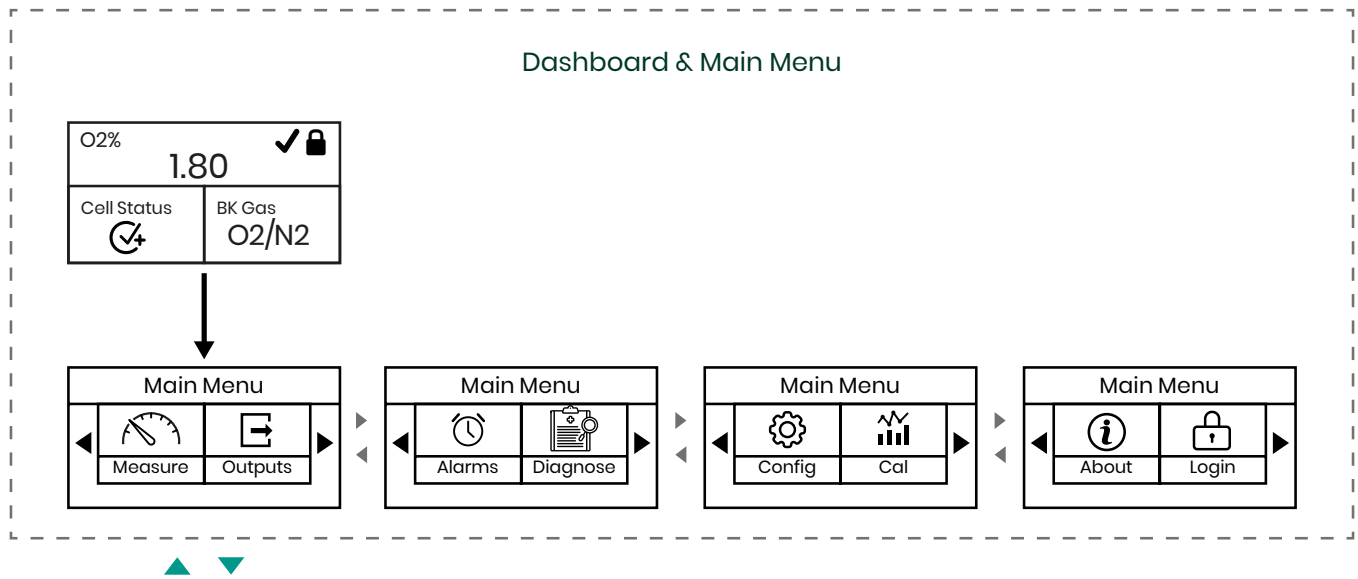

## D.2 Measure Menu

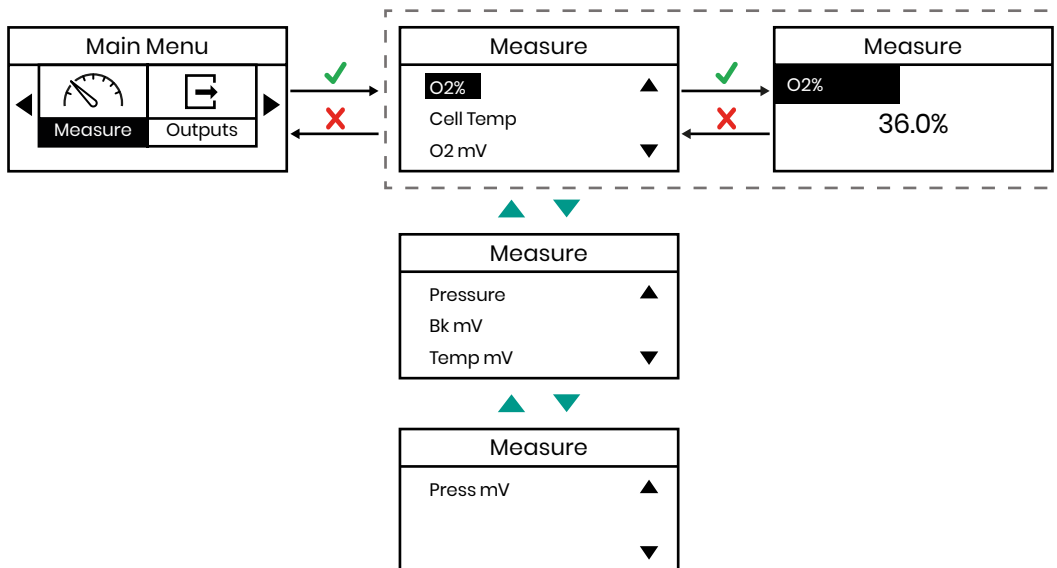

### D.3 Outputs Menu

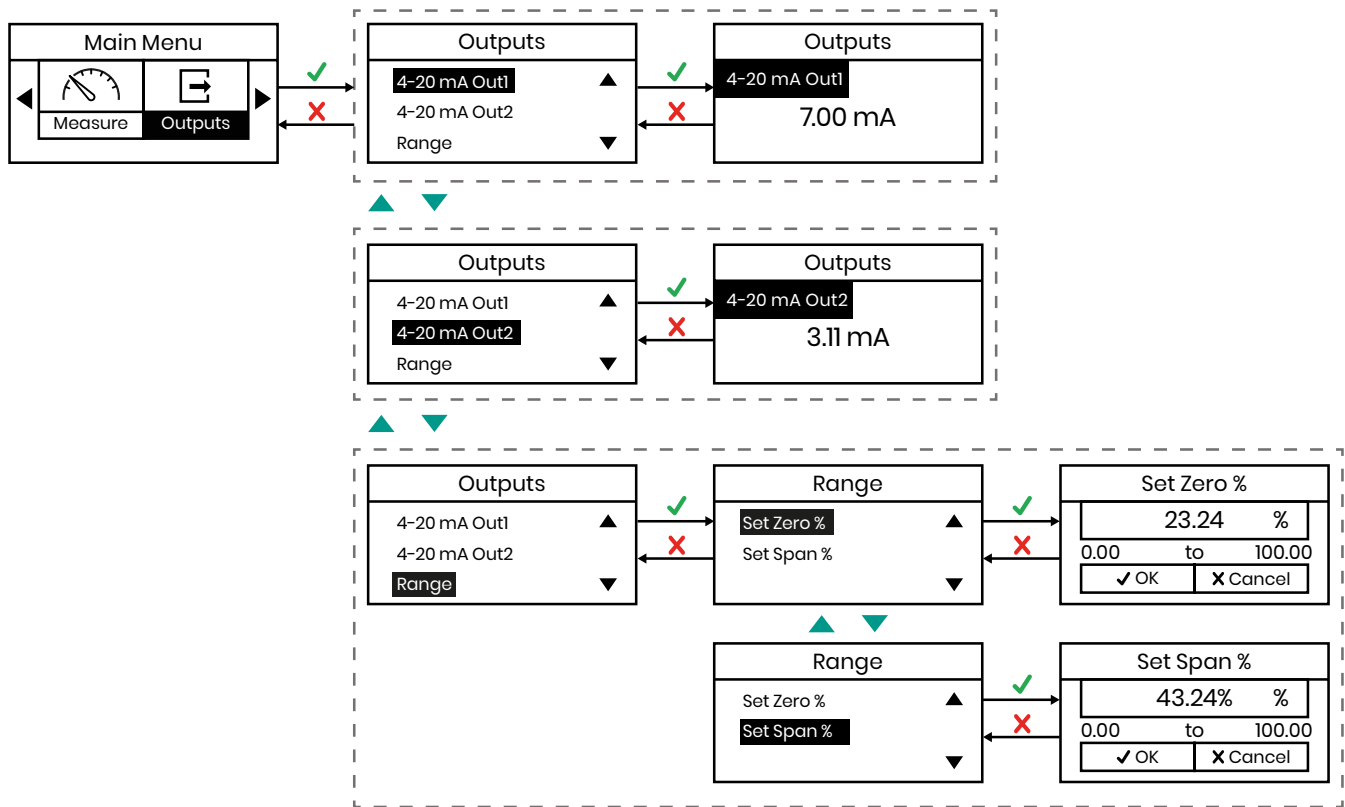

## D.4 Alarms Menu

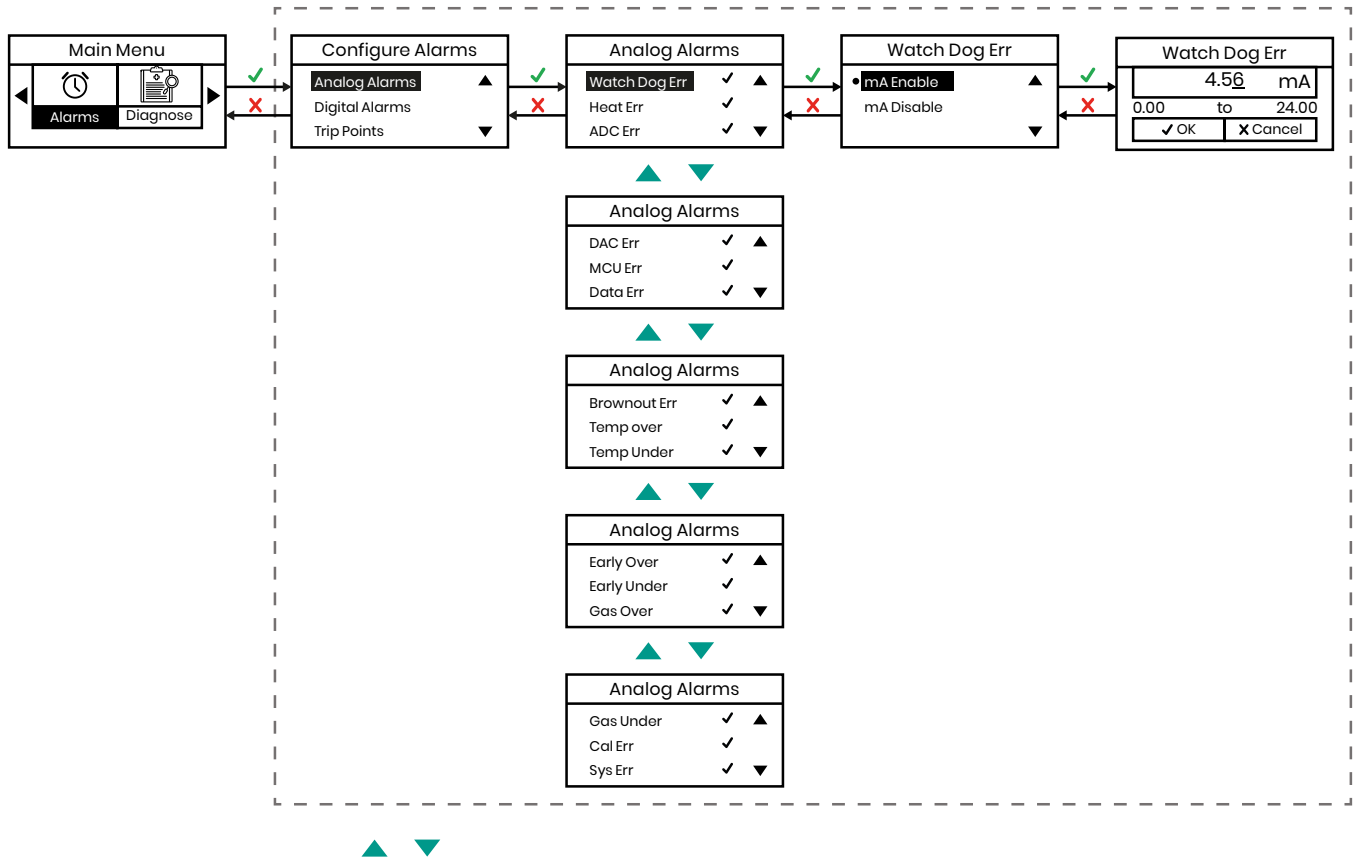

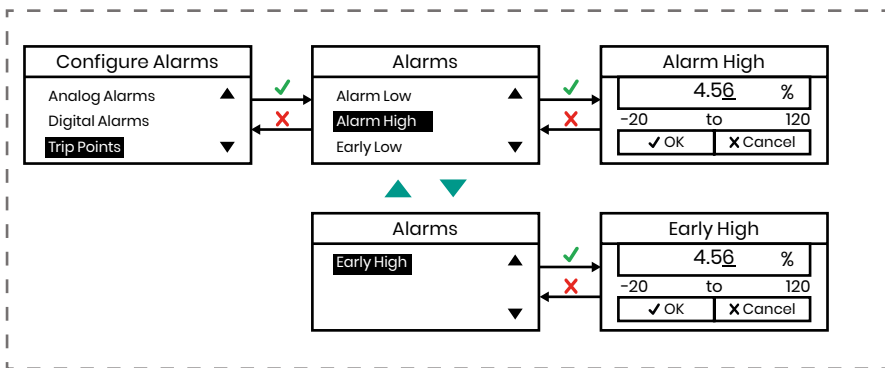
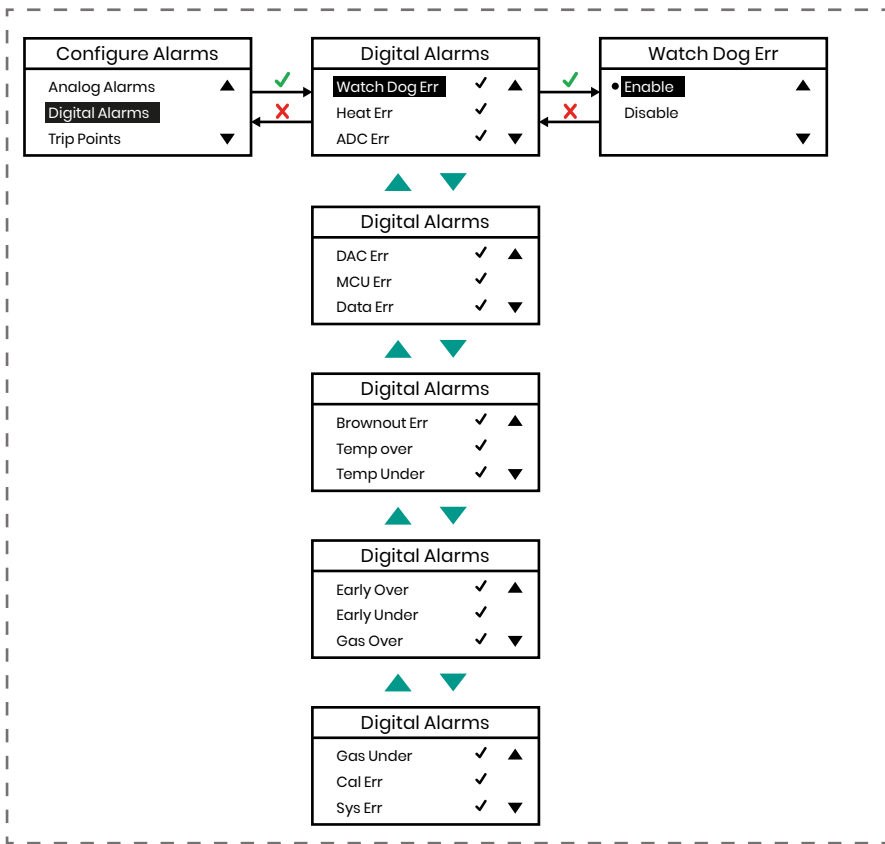

### D.5 Diagnose Menu

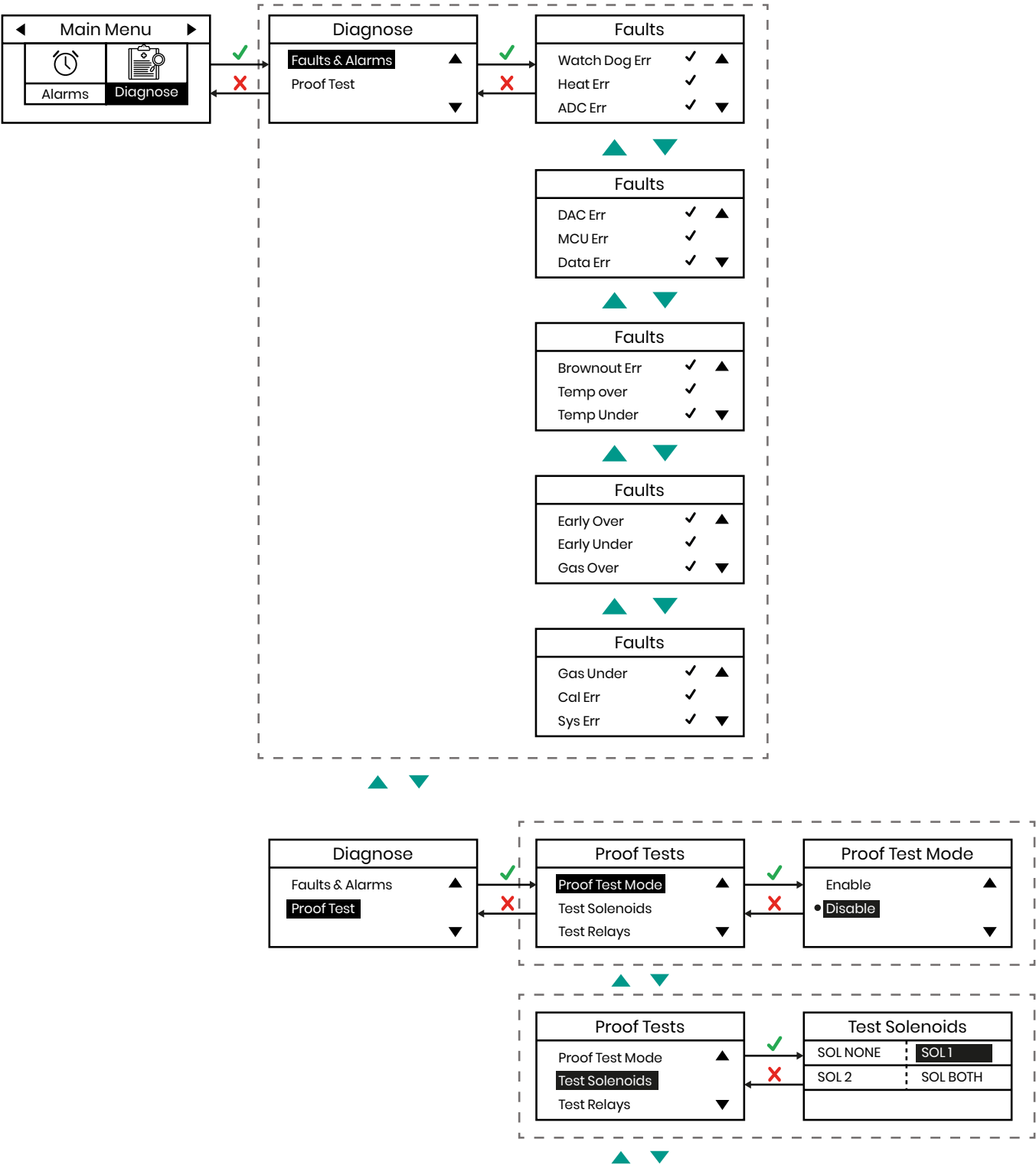

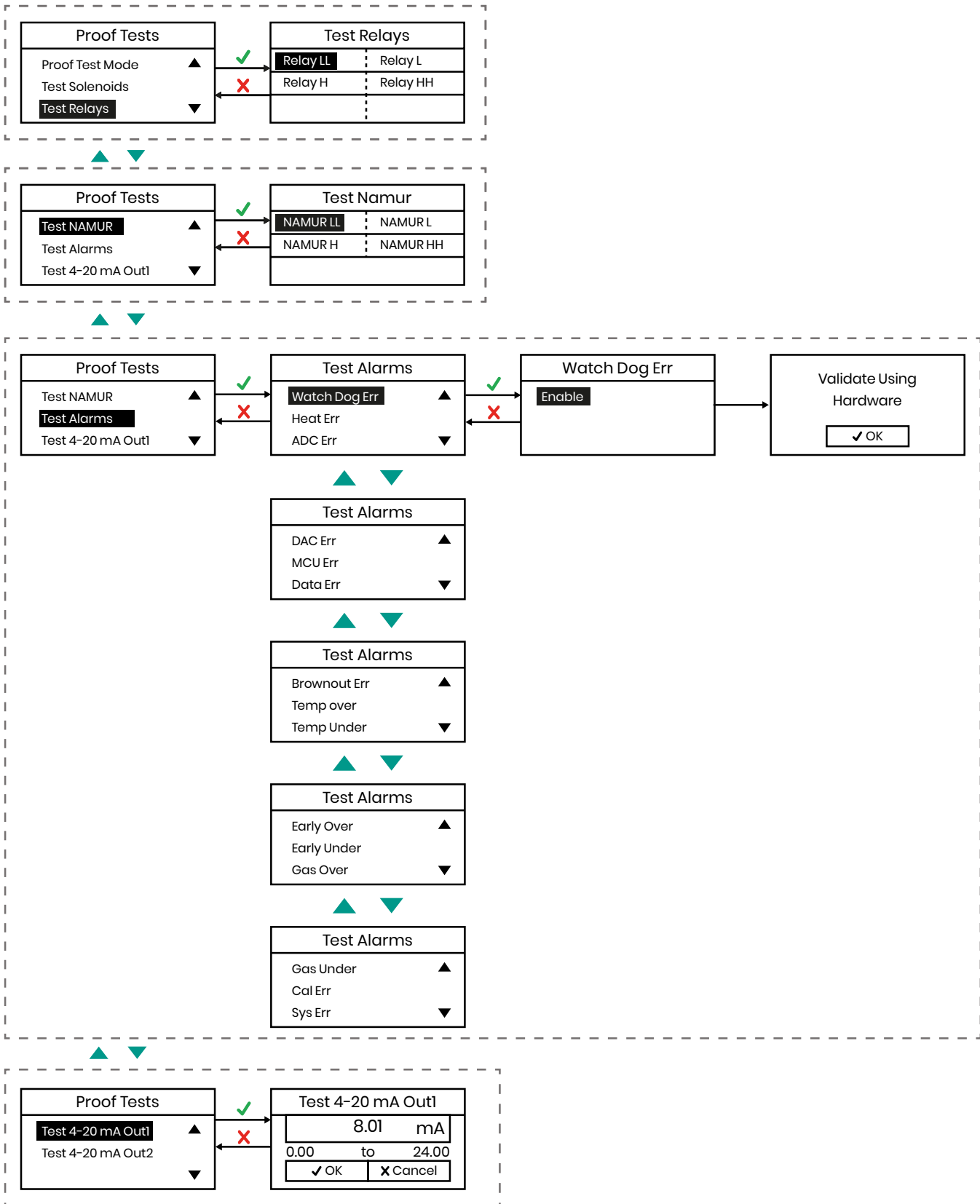

## D.6 Config Menu



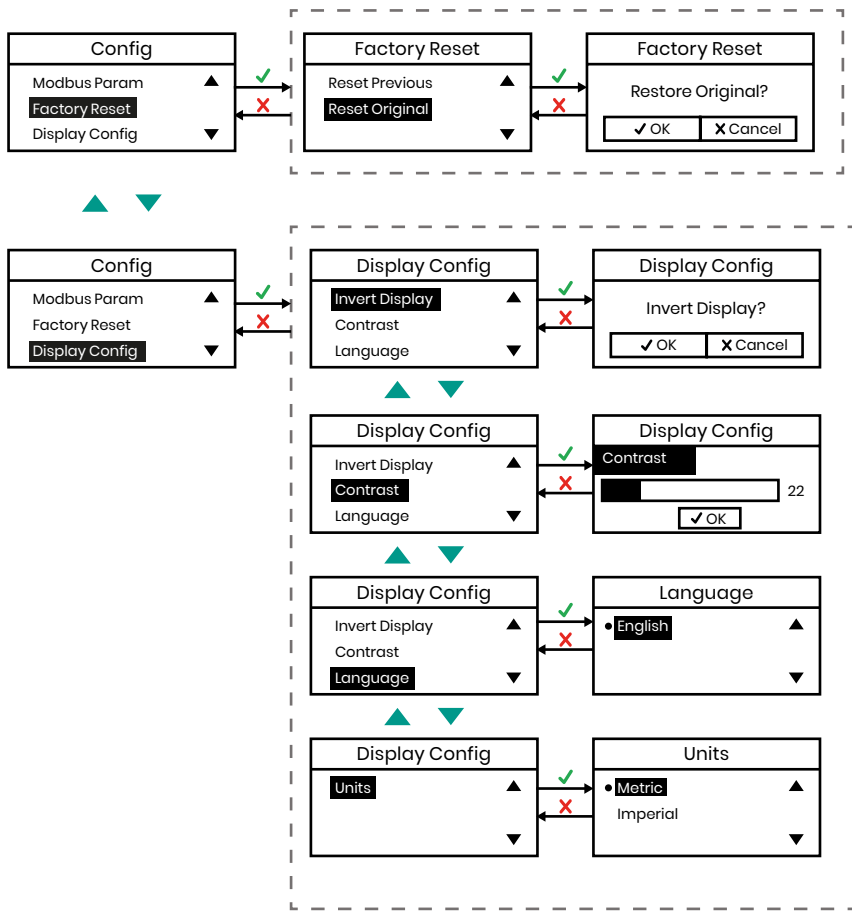

## D.7 Cal Menu

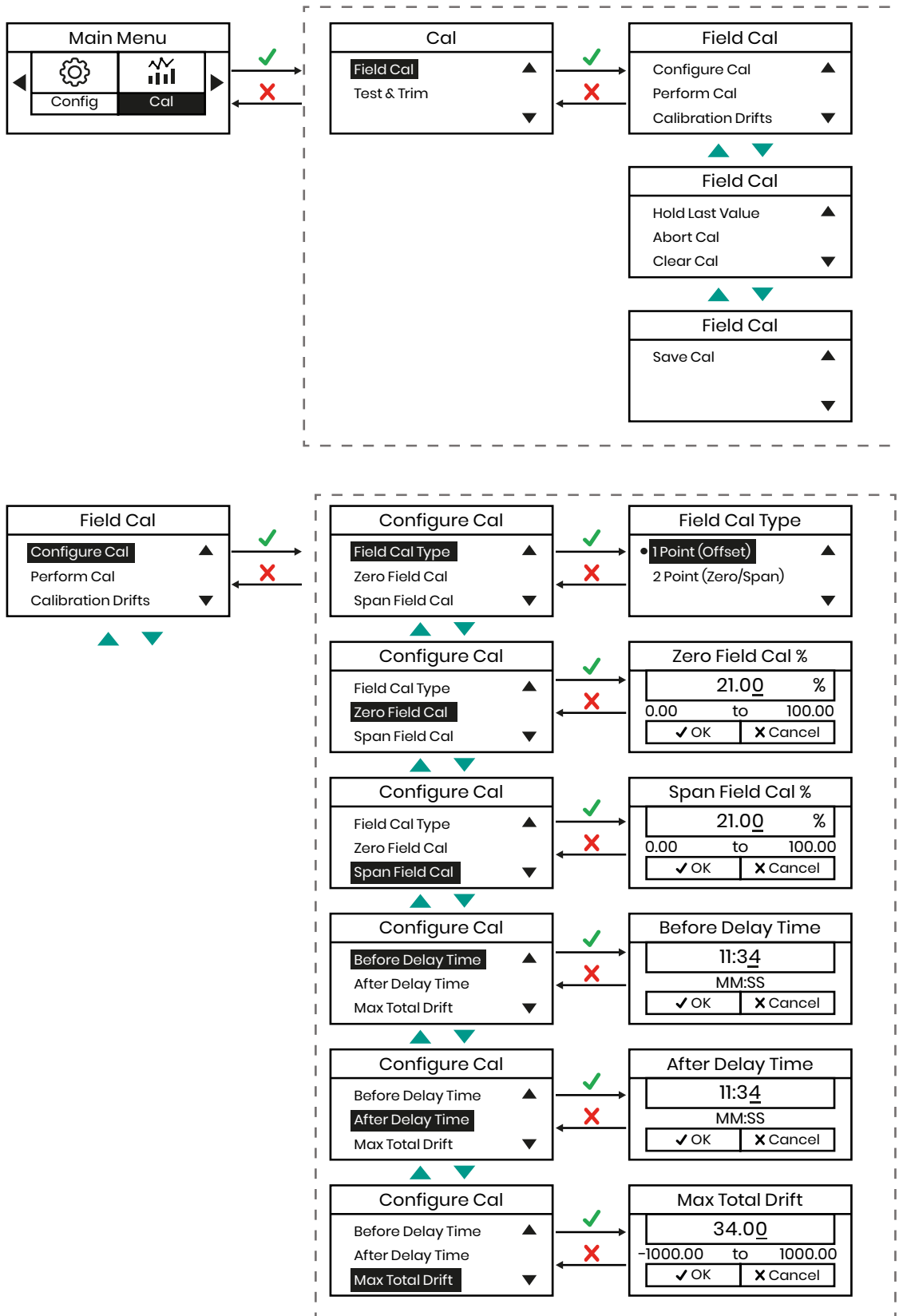

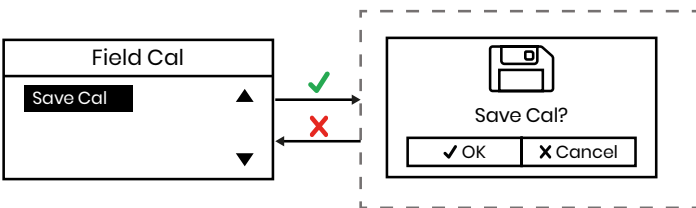
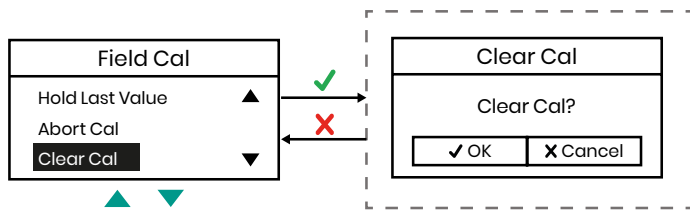
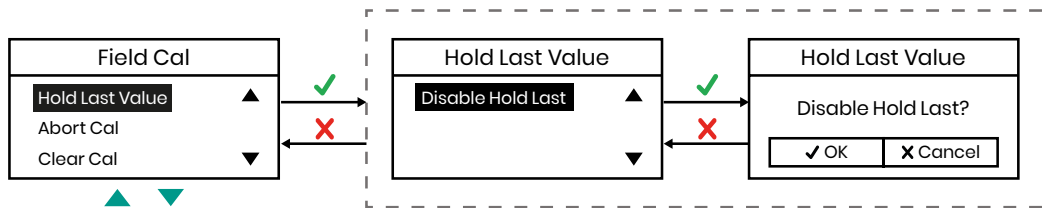
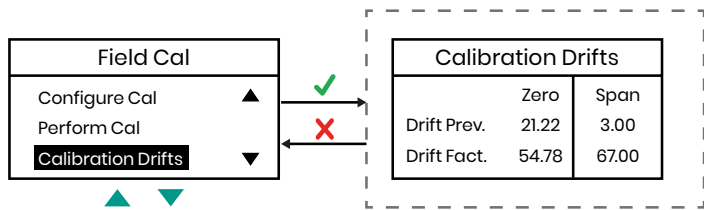
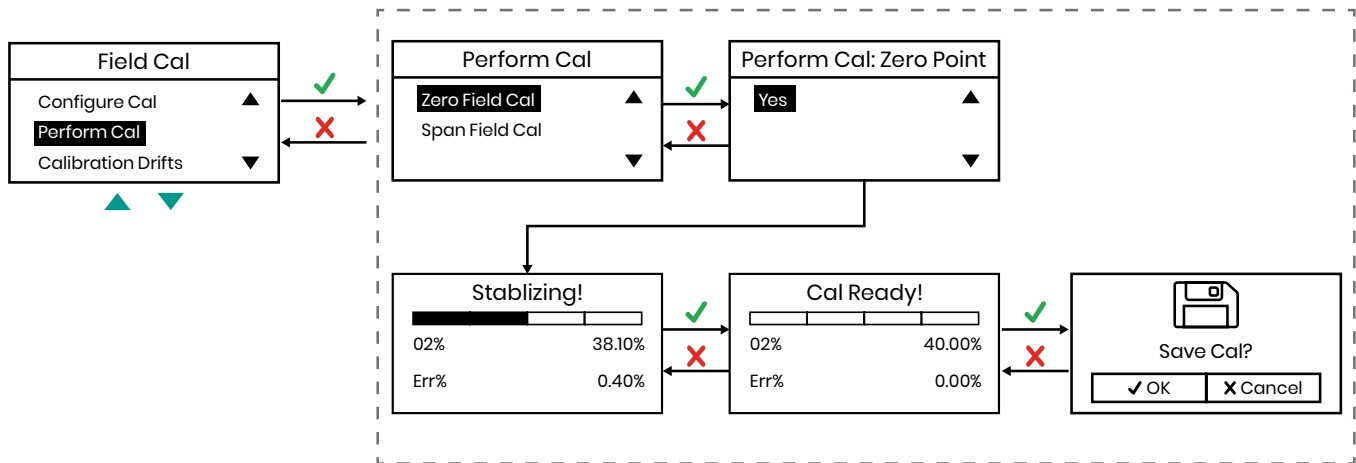

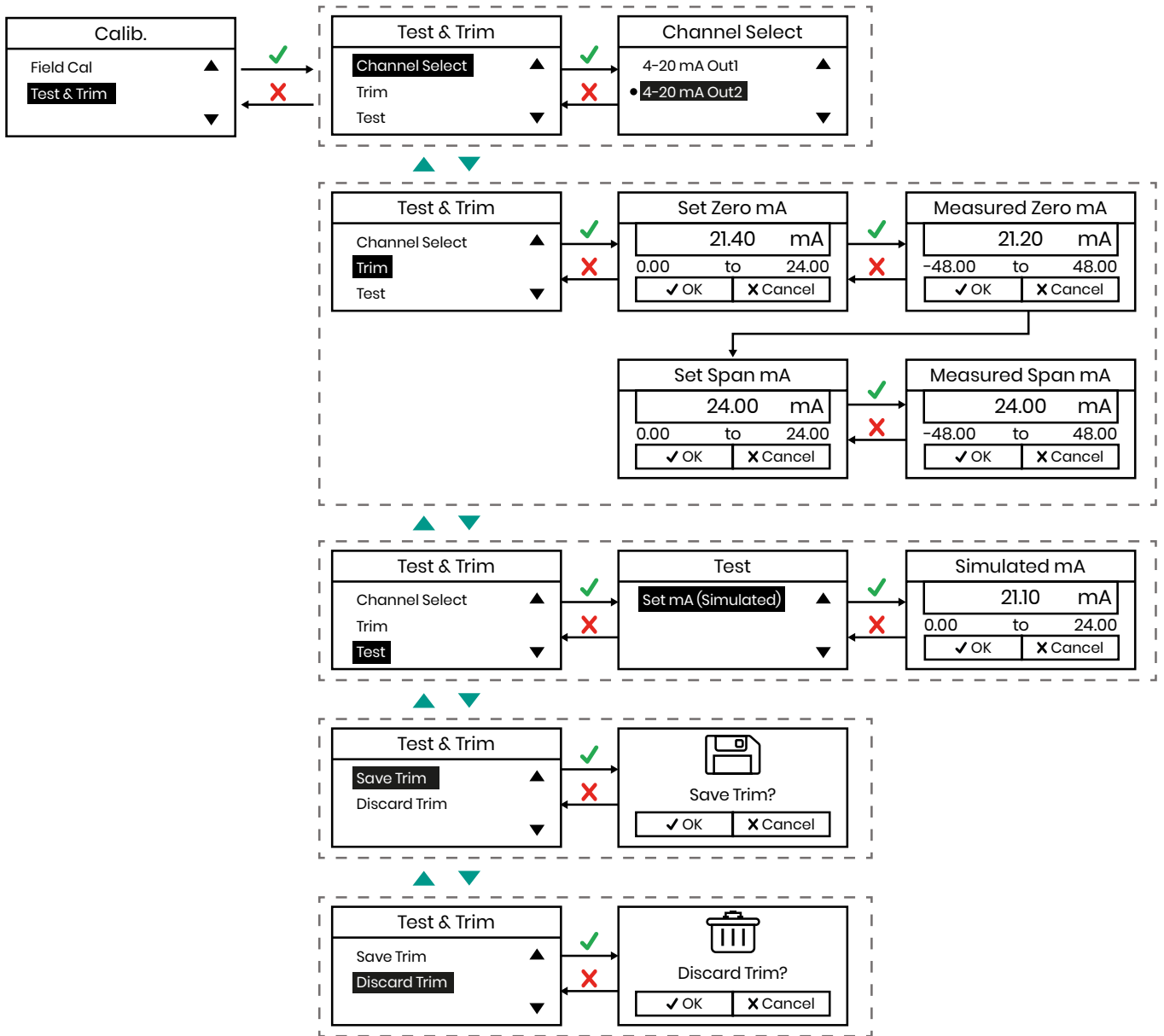

## D.8 About Menu

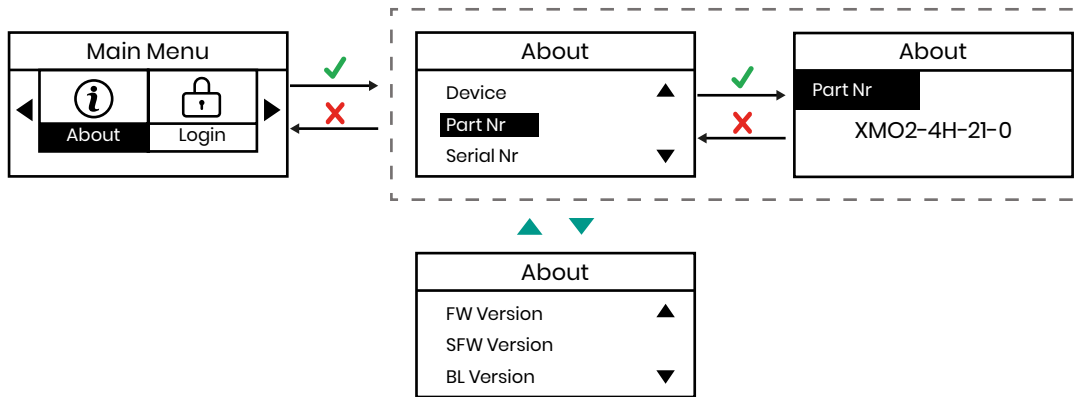

## D.9 Login Menu

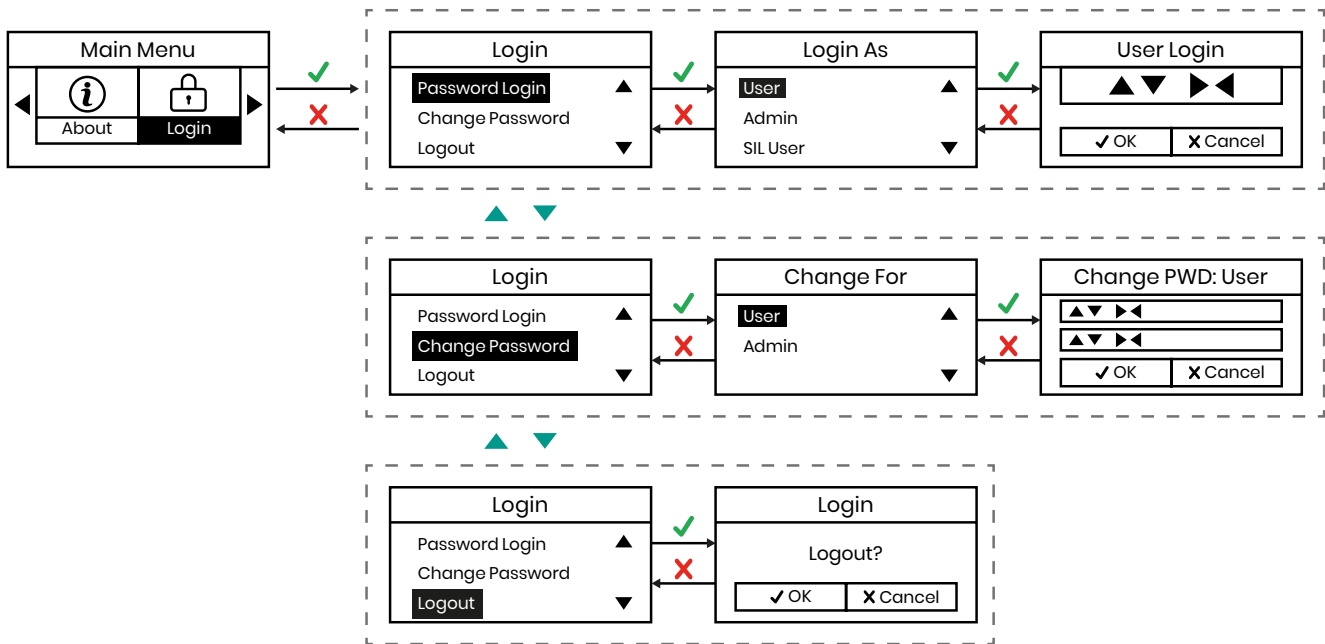

## Appendix E. CE Mark Compliance



**WARNING!** To meet CE Mark requirements, you must shield and ground all electrical cables as described in this section (see *Table 4* below).



**WARNING!** CE Mark compliance is required for all units installed in EU countries.



**WARNING!** Cable entries of an approved flameproof design are required. These must be installed according to the manufacturer's instructions the choice of cable entry device may limit the overall installation category achieved.



**WARNING!** It is the responsibility of the user to ensure that all cable entry devices and covers are properly installed and secure prior to applying power to the XMO2pro.

**Table 4: Wiring requirements for CE Mark compliance**

Connection	Termination Modification
Power, Analog Outputs and Relay Outputs	<ol style="list-style-type: none"> <li>1. When connecting the line power, analog outputs, and relay output cables, select the cable entry closest to the terminal blocks as shown in the wiring diagram in <i>Section 2.4.3</i></li> <li>2. Use shielded cable*.</li> <li>3. Terminate the shield to the cable gland.</li> </ol>
RS232/RS485 Output	<ol style="list-style-type: none"> <li>1. Use shielded cable* to interconnect the XMO2pro enclosure with any external I/O devices.</li> <li>2. Terminate the shield to the cable gland.</li> </ol>

\*Wires enclosed in a properly grounded metal conduit do not require additional shielding

[no content intended for this page]

## Appendix F. Abbreviations

Abbreviation	Meaning
HMI	Human Machine Interface
LCD	Liquid-Crystal Display
Cal	Calibration
SIL	Safety Integrity Level
PC	Personal Computer
ERR	Error
CH1	Channel 1
CH2	Channel 2
LED	Light Emitting Diode
4-20 mA Out 1	Analog Output 1
4-20 mA Out 2	Analog Output 2
Config	Configuration

[no content intended for this page]

## Appendix G. Typical Application Examples

### G.1 Blanketing Gases in Hydrocarbon Liquid Storage Tanks

The XMO2pro transmitter and its associated sample system is often used to measure the concentration of oxygen ( $O_2$ ) in the nitrogen ( $N_2$ ) or carbon dioxide ( $CO_2$ ) gases used to blanket hydrocarbon liquids during storage.

#### G.1.1 The Problem

Air can leak into the vapor space above hydrocarbon liquids stored in tanks or process vessels, forming a potentially explosive gas mixture. To solve this problem, inert gases such as  $N_2$  or  $CO_2$  are often used to purge the vapor space above the stored liquid and dispel any  $O_2$  that may have leaked into that space. In such a system, one must constantly monitor the level of  $O_2$  in the vapor space to make sure that an explosive gas mixture does not form.

#### G.1.2 Equipment Used

A typical instrumentation package for this application includes an XMO2pro transmitter configured for a range of 0-21%  $O_2$  in  $N_2$  or  $CO_2$  and operating conditions of ambient temperature and atmospheric pressure. The XMO2pro is mounted in a sample system similar to the one shown in *Figure 13* below (ref. dwg. #SS23D).

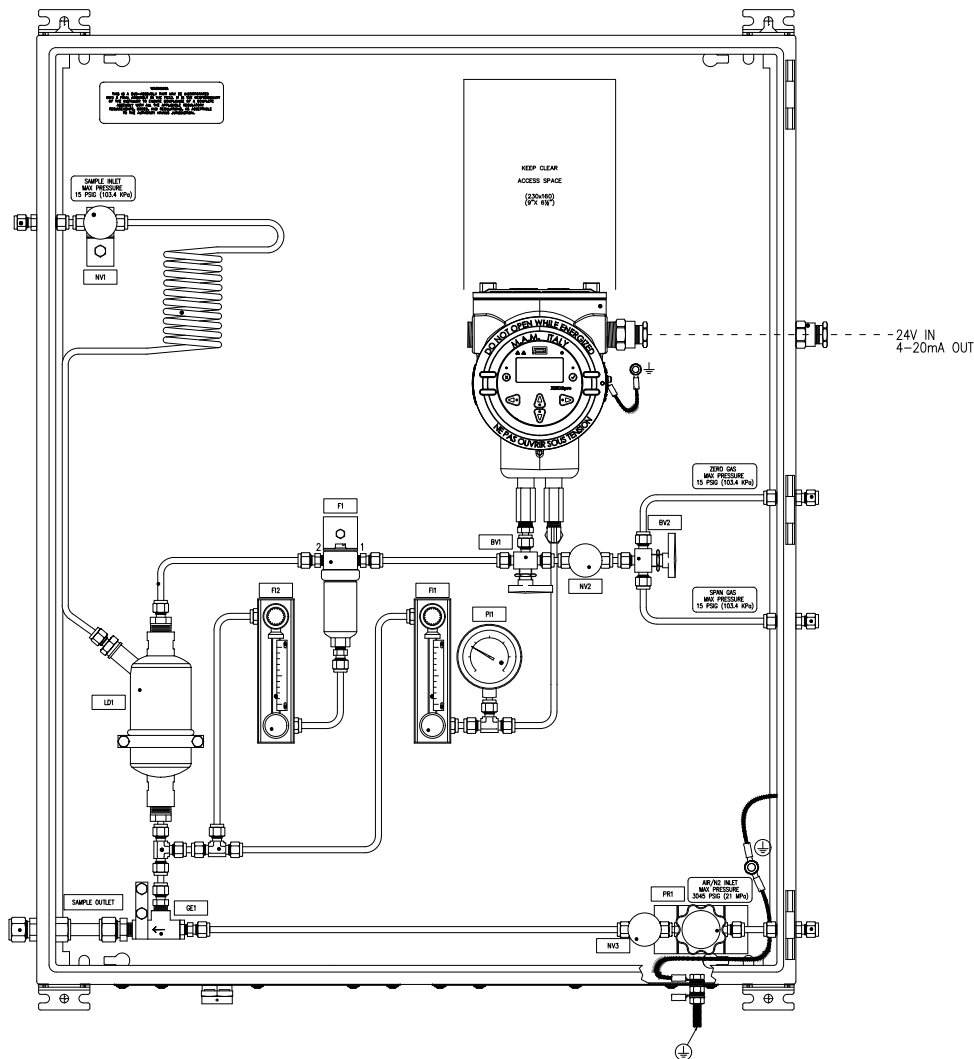

Figure 13: Blanketing gas sample system

A typical sample system in *Figure 13 on page 75* consists of:

- An eductor to draw the sample from and return it to the vapor space above the liquid in the storage tank.
- A liquid separator/dump to remove condensable liquids.
- A filter/coalescer for the removal of solid and liquid particulates.
- Flowmeters.
- Pressure gauges.

All components are mounted on a painted steel plate that may be housed in a heated enclosure.

### **G.1.3 Basic Operating Procedure**

The sample system should be located at or near the top of the storage tank so that condensate can drip back into the tank. The gas used to purge the tank provides the motive force in the eductor to pull a gas sample from the vapor space above the hydrocarbon liquid into the sample system. The sample gas, condensed liquids, and the inert gas are all returned to the tank, making this a closed-loop system. The XMO2pro is recalibrated periodically using the purge gas to zero the instrument and ambient air (20.93% O<sub>2</sub>) to span the instrument. The span gas can optionally be vented to atmosphere, so that air is not introduced into the storage tank.

For this application the required calibration gases are:

- Zero Gas: N<sub>2</sub> or CO<sub>2</sub> (at least 99.95% pure)
- Span Gas: air (20.93% O<sub>2</sub>)

### **G.1.4 Previous Systems**

Electrolytic cells were once commonly used for this application. However, such systems required extensive maintenance and frequent manual calibration. In addition, the cells were easily damaged by condensable liquids, requiring frequent cell replacement. As the XMO2pro provides continuous monitoring of the O<sub>2</sub> content with maintenance free operation, it is now the system of choice.

## G.2 Reactor Feed Gases in Formaldehyde Production

The XMO2pro transmitter and its associated sample system is often used to measure the concentration of oxygen ( $O_2$ ) in an air/ methanol ( $CH_3OH$ ) vapor mixture that is commonly used as a reactor feed gas in the production of formaldehyde.

### G.2.1 The Problem

In order to maximize the yield of the reaction, while maintaining the  $O_2$  concentration at a safe level, the air/ $CH_3OH$  vapor mixture must be continuously monitored and accurately controlled.

### G.2.2 Equipment Used

A typical instrumentation package for this application includes an XMO2pro transmitter configured for a range of 0–21%  $O_2$  in  $N_2$  or  $CO_2$  and operating conditions of a controlled temperature and atmospheric pressure. The XMO2pro is mounted in a sample system similar to the one shown in *Figure 14* below (ref. dwg. #SS35D).

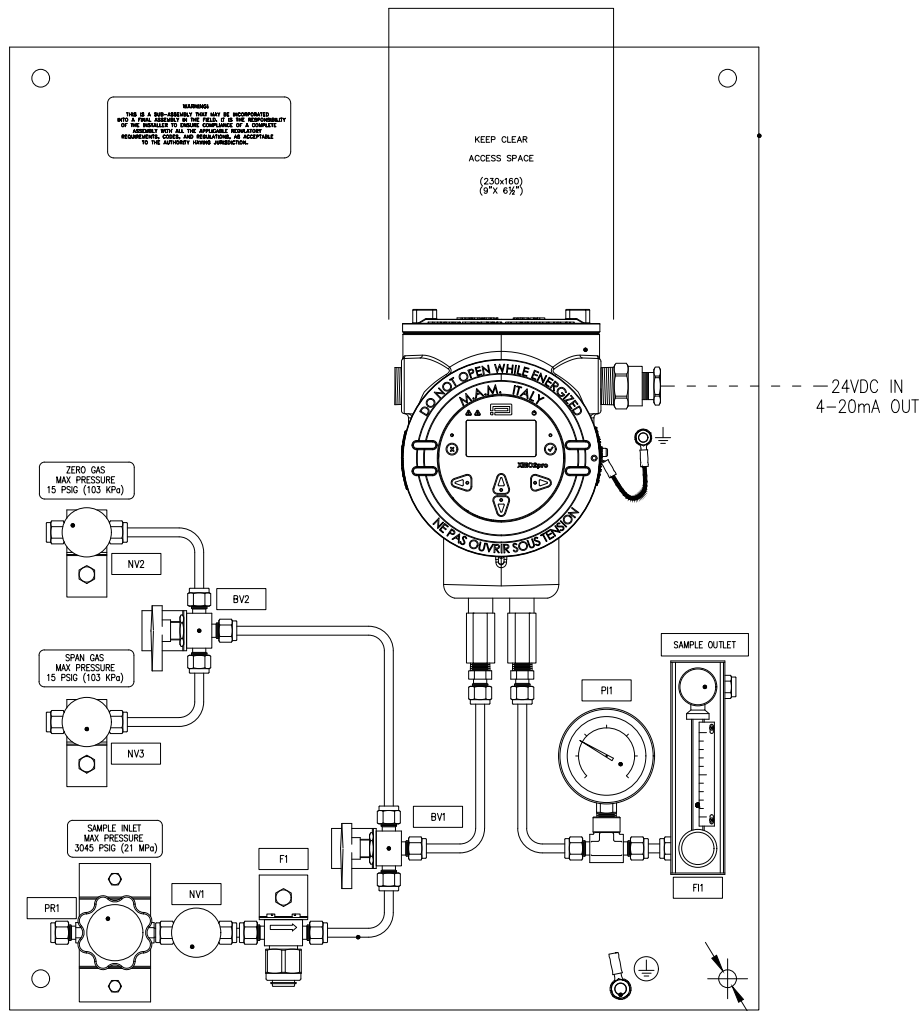

**Figure 14: Formaldehyde feed gas sample system**

The sample system in *Figure 14* consists of:

- Inlet, outlet, and calibration needle valves
- A filter/coalescer assembly
- Pressure gauges

- Flowmeters

All components are mounted on a painted steel plate in an enclosure that is heated to 75 ±10°F.

### **G.2.3 Basic Operating Procedure**

The sample system should be mounted as close as possible to the reactor inlet in order to minimize lag time. Air (20.93% O<sub>2</sub>) is used as the source of O<sub>2</sub>, and the air/CH<sub>3</sub> OH vapor mixture is sampled at the reactor inlet. The XMO2pro continuously verifies that the optimal amount of O<sub>2</sub> (typically 9.8%) is present for the reaction to proceed safely to a maximized yield. Too low an O<sub>2</sub> level will decrease the yield, while too high an O<sub>2</sub> level will create a safety hazard.

For this application the required calibration gases are:

- Zero Gas: N<sub>2</sub> (at least 99.95% pure - 0.0% O<sub>2</sub>)
- Span Gas: air (20.93% O<sub>2</sub>)

### **G.2.4 Previous Systems**

Dumbbell-type paramagnetic O<sub>2</sub> sensors were once commonly used for this application. However, such systems required extensive maintenance and frequent manual calibration. In addition, the sensors were easily damaged by condensable liquids, requiring frequent sensor replacement. As the XMO2pro provides continuous, accurate monitoring of the reactor feed gas O<sub>2</sub> content with maintenance-free operation and excellent calibration stability, it is now the system of choice.

# Appendix H. Calibration Sheet



## XMO2Pro CALIBRATION SHEET

Tag #	NA	
XMO2Pro Ser # :	25C00AA1	
XMO2Pro P/No. :	XMO2PRO-4-1-4-1-0-2-0-NON-SIL-S	
Software Revision:	VER 0.9.90	
Calibration Gases :	N2 / CO2	
Calibration Range:	0-2% O2	
Work Order Number:	1739433	
Temperature:	High Operating Temperature	
Calibration Date:	29/02/2025	
Technician:	B Slevin	

Default Passwords:	Decimal	HMI
User:	7951	▲▲▲▲▲▲▲▲
Admin:	7852	▲▼▲▼▲▼▲▼
SIL:	NA	NA

The default user profile password is "▲▲▲▲▲▲▲▲" (eight times up key)

XMO2 Enable Compensation	Background	XMO2 Oxygen Grid	XMO2 Recorder
Yes	N2/CO2	2 PTS, 2 CURVES	4-20mA 0-2% O2

Curve 1 - Nitrogen (N2)				
PT	%O2	O2 (mV)	Comp (mV)	O2 Output (mA)
1	0.00	-39.40	363.70	4.00
2	2.00	88.30	363.90	20.00

Curve 2 - Carbon Dioxide (CO2)				
PT	%O2	O2 (mV)	Comp (mV)	O2 Output (mA)
1	0.00	-9.40	333.80	4.00
2	2.00	206.40	335.50	20.00

### Field Calibration: Recommended values

**ZERO**:- Apply 100%N2

**SPAN**:- Apply 2% O2/N2

### BAKER HUGHES EMEA Unlimited Company , SHANNON

(EN) We hereby certify this Product has been manufactured and calibrated to product specification

(JP) この製品が製品仕様に合わせて製造され、校正されていることをここに証明します

(CN) 我们特此证明本产品已按照产品规格制造和校准

(DE) Wir bestätigen hiermit, dass dieses Produkt gemäß den Produktspezifikationen hergestellt und kalibriert wurde

(FR) Nous certifions par la présente que ce produit a été fabriqué et calibré selon les spécifications du produit

(ES) Por la presente certificamos que este Producto ha sido fabricado y calibrado según las especificaciones del producto.

(PT) Certificamos que este produto foi fabricado e calibrado de acordo com as especificações do produto

[no content intended for this page]

---

## Warranty

Each instrument manufactured by Panametrics is warranted to be free from defects in material and workmanship. Liability under this warranty is limited to restoring the instrument to normal operation or replacing the instrument, at the sole discretion of Panametrics. Fuses and batteries are specifically excluded from any liability. This warranty is effective from the date of shipment to the original purchaser. If Panametrics determines that the equipment was defective, the warranty period is:

- The earlier of one (1) year from first use or eighteen (18) months from shipment for electronic or mechanical failures.
- One year (1) from shipment for sensor shelf life (for products with replaceable sensors).

If Panametrics determines that the equipment was damaged by misuse, improper installation, the use of unauthorized replacement parts, or operating conditions outside the guidelines specified by Panametrics, the repairs are not covered under this warranty.

---

**The warranties set forth herein are exclusive and are in lieu of all other warranties whether statutory, express or implied (including warranties or merchantability and fitness for a particular purpose, and warranties arising from course of dealing or usage or trade).**

---

## Return Policy

If a Panametrics instrument malfunctions within the warranty period, the following procedure must be completed:

1. Notify Panametrics, giving full details of the problem, and provide the model number and serial number of the instrument. If the nature of the problem indicates the need for factory service, Panametrics will issue a Return Material Authorization (RMA), and shipping instructions for the return of the instrument to a service center will be provided.
2. If Panametrics instructs you to send your instrument to a service center, it must be shipped prepaid to the authorized repair station indicated in the shipping instructions.
3. Upon receipt, Panametrics will evaluate the instrument to determine the cause of the malfunction.

Then, one of the following courses of action will then be taken:

- If the damage is covered under the terms of the warranty, the instrument will be repaired at no cost to the owner and returned.
- If Panametrics determines that the damage is not covered under the terms of the warranty, or if the warranty has expired, an estimate for the cost of the repairs at standard rates will be provided. Upon receipt of the owner's approval to proceed, the instrument will be repaired and returned.

[no content intended for this page]





Scan here or use the link below for  
Customer Service, Technical Support,  
or Service Information:  
<https://panametrics.com/support>

Technical Support email:  
[panametricstechsupport@bakerhughes.com](mailto:panametricstechsupport@bakerhughes.com)

Copyright 2025 Baker Hughes company.

This material contains one or more registered  
trademarks of Baker Hughes Company and its  
subsidiaries in one or more countries. All third-party  
product and company names are trademarks of their  
respective holders.

BH079C11 EN A (03/2025)

**Baker Hughes** 