

# MSI-4260M

*Port-A-Weigh Crane Scale*

## Technical Manual



An ISO 9001 registered company  
© Rice Lake Weighing Systems. All rights reserved.

Rice Lake Weighing Systems® is a registered trademark of  
Rice Lake Weighing Systems.

All other brand or product names within this publication are trademarks or  
registered trademarks of their respective companies.

All information contained within this publication is, to the best of our knowledge, complete and  
accurate at the time of publication. Rice Lake Weighing Systems reserves the right to make  
changes to the technology, features, specifications and design of the equipment without notice.

The most current version of this publication, software, firmware and all other product  
updates can be found on our website:

[www.ricelake.com](http://www.ricelake.com)

# Contents

<b>1.0</b>	<b>Introduction</b>	<b>1</b>
1.1	Safety	1
<b>2.0</b>	<b>Installation</b>	<b>2</b>
2.1	Unpacking	2
2.2	Dimensions	2
2.3	Batteries	3
2.3.1	Battery Replacement	3
2.4	Communications Port	4
2.4.1	Communications Port Cables	4
2.5	Radio Compliance	5
2.5.1	FCC Statement	5
2.6	Antenna	6
2.7	Servicing	6
2.7.1	Remove Front Casting	6
2.7.2	Reinstall Front Casting	6
2.8	Options	6
<b>3.0</b>	<b>Operation</b>	<b>7</b>
3.1	Display	7
3.1.1	Keypad Functions	7
3.1.2	Annunciator Functions	7
3.2	Power	8
3.3	Zero	8
3.4	Tare	8
3.5	User	9
3.6	Menu Navigation	9
<b>4.0</b>	<b>Setup</b>	<b>10</b>
4.1	Setup Menu	10
4.2	Function User Keys	11
4.2.1	Set Function Key	11
4.2.2	Test	11
4.2.3	Total	12
4.2.4	View Total	12
4.2.5	Net/Gross	12
4.2.6	Peak Hold	12
4.2.7	Unit	12
4.2.8	Print	12
4.3	Auto-Off	12
4.4	Sleep	13
4.5	Display Backlight Brightness	13
4.6	Setpoints	14
4.7	Total	15
4.7.1	Manual Total	15
4.7.2	Auto Total	15
4.7.3	Set Total Mode	15
4.8	Filter	16



Technical training seminars are available through Rice Lake Weighing Systems. Course descriptions and dates can be viewed at [www.ricelake.com/training](http://www.ricelake.com/training) or obtained by calling 715-234-9171 and asking for the training department.

# Contents

4.9	Unit .....	16
4.10	Battery Life .....	16
<b>5.0</b>	<b>Calibration .....</b>	<b>17</b>
5.1	Calibration Switch Access .....	17
5.2	Calibration Menu .....	18
5.2.1	Standard Calibration .....	18
5.2.2	Auto Zero Maintenance .....	19
5.2.3	Zero Power Up .....	20
5.2.4	Filter .....	20
5.3	Initial Calibration .....	21
5.4	Guidelines for Capacity and Resolution .....	22
5.5	C-Cal Calibration .....	23
5.6	Calibration Setup Menu .....	24
5.6.1	Standard Menu .....	24
<b>6.0</b>	<b>Communications Setup .....</b>	<b>25</b>
6.1	Communications Menu .....	25
6.1.1	Printer and Serial Output Setup .....	26
6.1.2	RF Network Menu Setup .....	28
<b>7.0</b>	<b>Troubleshooting and Maintenance .....</b>	<b>30</b>
7.1	Troubleshooting Guide .....	30
7.2	Service Counters .....	31
7.2.1	Access the Service Counters .....	31
<b>8.0</b>	<b>Specifications .....</b>	<b>32</b>



Rice Lake continually offers web-based video training on a growing selection of product-related topics at no cost. Visit [www.ricelake.com/webinars](http://www.ricelake.com/webinars)

# 1.0 Introduction

The MSI-4260M Port-A-Weigh crane scale has an established reputation as the industry standard in medium to heavy-capacity overhead weighing and duty-cycle needs. With a proven mechanical design and advanced electronics, the MSI-4260M is versatile, reliable, accurate and user friendly.

The MSI-4260M is designed to meet or exceed requirements of applicable ASME, ANSI, OSHA safety standards. Multiple options and accessories, including the RF Rugged Remote Control and RF remote displays are available to further enhance the performance and application versatility of the MSI-4260M.



Manuals and additional resources are available from the Rice Lake Weighing Systems website at [www.ricelake.com](http://www.ricelake.com)

Warranty information can be found on the website at [www.ricelake.com/warranties](http://www.ricelake.com/warranties)

## 1.1 Safety

### Safety Signal Definitions:



**DANGER** Indicates an imminently hazardous situation that, if not avoided, will result in death or serious injury. Includes hazards that are exposed when guards are removed.



**WARNING** Indicates a potentially hazardous situation that, if not avoided, could result in serious injury or death. Includes hazards that are exposed when guards are removed.



**CAUTION** Indicates a potentially hazardous situation that, if not avoided, could result in minor or moderate injury.



**IMPORTANT** Indicates information about procedures that, if not observed, could result in damage to equipment or corruption to and loss of data.

### General Safety



**Do not operate or work on this equipment unless this manual has been read and all instructions are understood. Failure to follow the instructions or heed the warnings could result in injury or death. Contact any Rice Lake Weighing Systems dealer for replacement manuals.**



**Failure to heed could result in serious injury or death.**

**Do not allow minors (children) or inexperienced persons to operate this unit.**

**Do not stand near the load being lifted as it is a potential falling hazard. Keep a safe distance.**

**Do not use for purposes other than weight taking or dynamic load monitoring.**

**Do not use any load bearing component that is worn beyond 5% of the original dimension.**

**Do not use the scale if any of the components of the load train are cracked, deformed or show signs of fatigue.**

**Do not exceed the rated load limit of the scale, rigging elements or the lifting structure.**

**Do not allow multi-point contact with the hook, shackle or lifting eye of the scale.**

**Do not allow high torque on the scale unless it is specifically designed for high torque.**

**Do not make alterations or modifications to the scale or associated load bearing devices.**

**Do not use improperly rated or sized shackles. Use only Rice Lake Weighing Systems recommended shackles.**

**Do not remove or obscure warning labels.**

**For guidelines on the safe rigging and loading of overhead scales, read the Rice Lake Weighing Systems Crane Scale Safety and Periodic Maintenance Manual (available at [www.ricelake.com](http://www.ricelake.com)).**

**Keep hands, feet and loose clothing away from moving parts.**

**There are no user serviceable parts within the MSI-4260M. Any repairs are to be performed by qualified service personnel only.**

**The MSI-4260M Port-A-Weigh scale has a safe mechanical overload of 200% and an ultimate overload of 500%. Overloads greater than 50% could result in structural failure and dropped loads. Dropped loads could cause serious personal injury or death.**

## 2.0 Installation

This section provides an overview of MSI-4260M Port-A-Weigh crane scale installation instructions.

The MSI-4260M features a heavy duty, IP66 cast aluminum enclosure. The MSI-4260M installs easily by hanging it on a crane using properly sized shackles.



### WARNING

**Refer to the Crane Scale Safety and Periodic Maintenance Manual (PN 153105) for safe loading and rigging guidelines when installing the MSI-4260M.**

**Regular maintenance inspections of the lifting system should be performed to ensure safety. Pay attention for signs of stress on any element in the load train.**

Use the appropriate interface hardware for the capacity of the scale.

- If the interface hardware does not fit properly, Rice Lake Weighing Systems can supply the MSI-4260M with oversize lifting eyes or shackle interfaces
- If the crane hook is too large to fit in the lifting eye with single point interface then install the scale using adaptive rigging
- If multiple attachments are needed, use a shackle or ring to attach the multiple lines to keep a single point attachment to the scale

### IMPORTANT

**Using an oversize shackle or hook to interface with the MSI-4260M can cause off center loading and stress points that reduce the life of the lifting eye or hook.**

**Single point attachments are necessary to ensure the safety and accuracy of the scale system.**

## 2.1 Unpacking

Immediately after unpacking the MSI-4260M from the shipping container, visually inspect the product to ensure all components are included and undamaged. If parts were damaged in shipment, notify Rice Lake Weighing Systems and the shipper immediately. If the MSI-4260M must be returned, it must be properly packed with sufficient packing materials.

Whenever possible, use the original carton when shipping the unit back. It is good practice to retain the shipping container for future shipping or transporting of the unit.

## 2.2 Dimensions

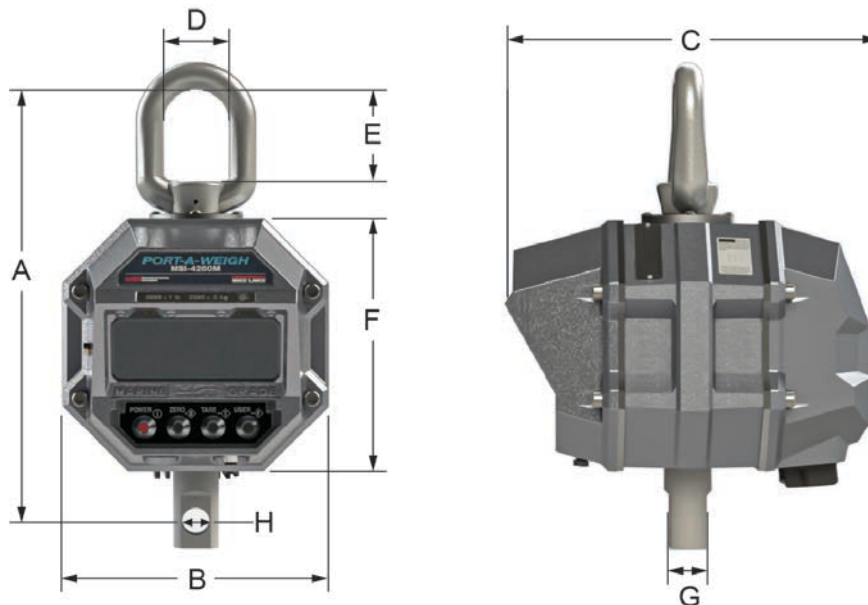

Figure 2-1. Product Diagram

A	B	C	D	E	F	G	H
16.28" (413.5 mm)	10.00" (254.0 mm)	13.52" (343.4 mm)	2.50" (63.5 mm)	3.50" (88.9 mm)	9.28" (235.7 mm)	1.35" (34.3 mm)	Ø 1.03" (26.1 mm)

Table 2-1. Product Dimensions (PN 194593)

## 2.3 Batteries



**Note** For optimal performance, replace all six batteries with new batteries from the same type and manufacturer.

The MSI-4260M is powered by six (6) D cell 1.5 V alkaline batteries. The operating battery life is up to 1000 hours depending on the following factors:

- The brightness of the LCD display backlight
- The amount of RF activity
- The age and condition of the batteries

In order to conserve battery life, the MSI-4260M includes the following features.

- **Automatic Power Off Mode** – Senses no activity after the set amount of minutes and turns the scale off
- **Automatic Sleep Mode** – Dims the display after a set amount of minutes of no scale activity

Do not store the MSI-4260M with the batteries inside. Remove the batteries if the unit will not be used for more than two weeks.



**Note** Replace batteries once the battery annunciator is flashing.

### 2.3.1 Battery Replacement

1. Turn the MSI-4260M off.
2. Unscrew battery caps.
3. Slide battery tubes from the MSI-4260M.
4. Remove batteries from tubes.
5. Install new batteries with plus side up.
6. Reinstall battery tubes.



Figure 2-2. Battery Replacement

#### IMPORTANT

Periodically, inspect o-rings and threads to maintain a tight seat of the battery tubes.



Batteries and battery tubes can be a dangerous falling hazard. When opening battery tubes, be sure to hold to prevent from falling.

## 2.4 Communications Port

The MSI-4260M has a single Communications Port allowing access to the embedded ScaleCore through the terminal access mode or Rice Lake software.

The terminal access mode is used for updating scale firmware while Rice Lake software can be used for calibration and configuration, backup and adjusting scale settings. This Communications Port is not intended for output use.

### 2.4.1 Communications Port Cables

The MSI-4260M comes standard with one communications port cable wired for RS-232 following the AT standard for 9-pin serial cables (DCE). An un-terminated cable is also available for wiring the serial cable for RS-232.

Table 2-2 shows the wiring color code.

Wire	Signal
Brown	TxD (transmitted data)
Black	RxD (received data)
Grey	CTS (clear to send)
White	RTS (request to send)
Blue	GND
Drain Wire	PG (protective ground)

Table 2-2. RS-232 Wiring Code

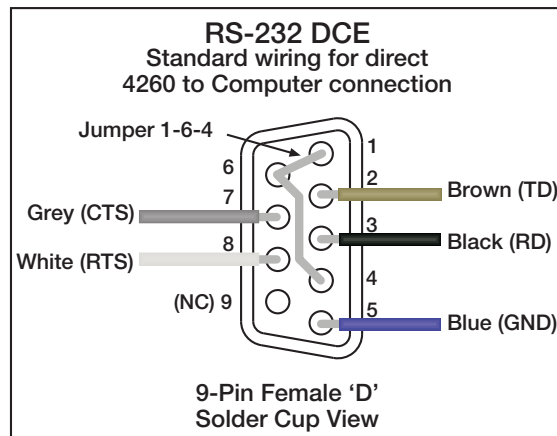

Figure 2-3. RS-232 DCE Port Cable Assignments

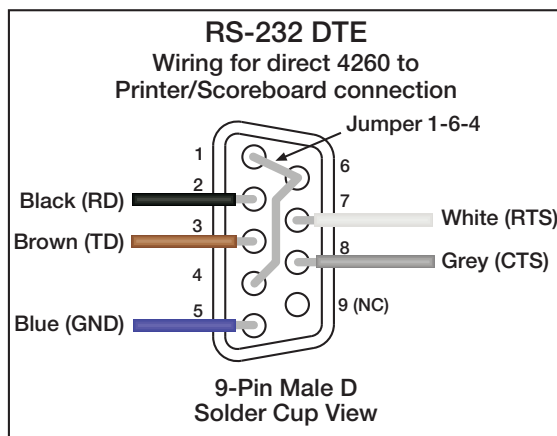

Figure 2-4. RS-232 DTE Port Cable Assignments

## 2.5 Radio Compliance

All radio options meet FCC and international radio compliance per the certification information listed in this section. These modules may have additional international certifications that are not listed in this section. Please contact Rice Lake Weighing Systems if you require operation in a jurisdiction that is not listed.

### 2.5.1 FCC Statement

The product complies with Part 15 of the FCC Rules. Operation is subject to the following conditions:

- This device may not cause harmful interference
- This device must accept any interference received, including interference that may cause undesired operation

#### 802.15.4 Contains FCC ID: MCQ-PS2CTH

#### 802.15.4 International Certifications

**Canada:** Radio Certificate Number: IC 1846A-PS2CTH

**Australia & New Zealand:** DIGI-090F15C247

The product is compliant with the following standards and/or other normative documents:

- Safety (article 3.1A) EN60950-1:2001
- EMC (article 3.1b) ETSI EN 301 489-1 v1.7.1 (2007-04) In accordance with the specific requirements of ETSI EN 301 489-17 v1.2.1 (2002-08)
- Spectrum (article 3.2) ETSI EN 300 328 v1.7.1 (2006-10)

#### Wi-Fi Contains FCC ID: T9J-RN171

#### Wi-Fi International Certifications

**Canada:** Radio Certificate Number: IC 6514A-RN171

**Korea:** Radio Certificate Number: KCC-CRI-029-RN-171

**Europe** – The product is compliant with the following standards and/or other normative documents:

- EN 300 328 : V1.8.1 (2012)

The product is compliant with the following standards and/or other normative documents:

- Safety (article 3.1A) EN 60950-1:2006+A11:2009+A1:2010+A12:2011
- EMC (article 3.1b) EN 301 489-1 : V1.9.2 (2011) In accordance with the specific requirements of ETSI EN 301 489-17: V2.2.1 (2012)

#### Bluetooth Contains FCC ID: T9J-R41-1

#### Bluetooth International Certifications

**Canada:** Radio Certificate Number: IC 6514A-RN411

**Europe** – The product is compliant with the following standards and/or other normative documents:

- EN 300 328-1
- EN 300 328-2 2.4GHz

#### FHSS (Frequency Hopper Spread Spectrum) Contains FCC ID: HSW-DNT24

#### FHSS International Certification

**Canada:** Radio Certificate Number: IC 4492A-DNT24

**ETSI Certified**

## 2.6 Antenna

The 2.4 GHz internal antenna is the standard type of antenna used for overhead scale applications and is only included in RF models. The internal antenna is resilient to the possible physical damage of outdoor application, but is directional, which requires more care in antenna placement for long range applications. Internal antennas are available by special order only. Please contact Rice Lake Weighing Systems for details.

Ensure a relatively clear transmission path exists between the devices to be connected. Make sure the antenna is not blocked by any metal. Transmission is good through most kinds of glass, so mounting next to a window works fine. Radio signals travel primarily by line of sight (LOS), obstructions between stations may degrade the system performance.



**Note** *The antenna is optional to a non-RF MSI-4260M unit. The antenna is standard to all RF MSI-4260M devices.*

## 2.7 Servicing

The Rice Lake dealer network provides both on-site and depot servicing of the MSI-4260M. Please contact a local dealer or Rice Lake Weighing Systems to obtain a return material authorization (RMA). Due to the weight and size of many products, it is not always necessary to return the entire unit. There are no user serviceable parts inside the MSI-4260M. Depot repair is performed with module and harness swaps. If the electronics are at fault, often the front casting is the only part needed to be returned.

### 2.7.1 Remove Front Casting

See the following procedure to remove the front casting:

1. Remove the cap screws (x4).
2. Unplug connectors.
3. Package the front casting well for safe shipping.

### 2.7.2 Reinstall Front Casting

See the following procedure to reinstall the front casting:

1. Clean the front casting and bulkhead o-ring grooves with isopropyl alcohol.
2. Reconnect the load cell cables and power cables then tighten the cables.
3. While securing the o-ring, ensure the o-ring is flush with the o-ring grooves.



**WARNING** *Replace damaged o-rings when necessary. Damaged o-rings may break the unit seal, causing water penetration.*

4. Insert the bolts (x4) into the front casting then torque the bolts to 20-25 ft-lbs.



**Note** *Apply anti-seize compound as necessary.*



Figure 2-5. Remove Front Casting

## 2.8 Options

See [Table 2-3](#) for available options:

Part No.	Option	Description
173014	RF Rugged Remote Control	100' (30 m) typical range Line-of-Sight; Uses 802.15.4, 2.4GHz; Handheld transceiver; Requires scale with 802.12.4 radio installed
139381	MSI-8000 RF Handheld Remote Display	300' (100 m) typical range Line-of-Sight; Uses 802.15.4, 2.4GHz; Requires scale with 802.12.4 radio installed
178004	4" LaserLight2	
178006	6" LaserLight2	
178281	8004HD Remote Display	
153591	MSI-8000HD RF Mountable Remote Display	
151095	MSI-8000 Audible Alarm	Is triggered by setpoint one
Consult	Bluetooth	Bluetooth communication for PC
Consult	802.11 Wi-Fi Connectivity	Wi-Fi Ethernet Network Communication

Table 2-3. Available Options

## 3.0 Operation

This section provides an overview of MSI-4260M Port-A-Weigh Crane Scale operation instructions.

### 3.1 Display

The keys and display of the MSI-4260M front panel are shown and described below:



Figure 3-1. Front Panel

#### 3.1.1 Keypad Functions

Key	Description
	POWER key – Turns the MSI-4260M On and Off
	ZERO key – Used to zero out residual weight on the scale
	TARE key – Removes the weight of containers, trucks or carriers and places the scale in the <b>Net Weight</b> mode
	USER key – Programmable to user selectable functions (Section 3.5 on page 9); This key is defaulted to the Test function

Table 3-1. Key Functions

#### 3.1.2 Annunciator Functions

Key	Description
	Battery Level – Displays representation of the battery level: 100%, 75%, 50%, 25% and 0%
	Center of Zero – Indicates that the scale is zeroed and the weight is within 1/4 d of zero
	Negative Sign – Allows scale to display five digits and a negative sign
	Stable – Indicates that the weight has settled within the motion window (usually $\pm 1$ d); When this symbol is off, the scale will not zero, tare or totalize
	Radio Frequency – Indicates an active radio communication link with a scale or indicator
	Setpoint LEDs – Eight user programmable setpoints for early overload warnings; <b>NOTE: Setpoints 1–3 are visible on the device. Setpoints 4–8 can only be used by connecting a compatible RF remote device.</b> Blue LED = Setpoint 1, Green LED = Setpoint 2, Red LED = Setpoint 3
	X1000 – Allows weight accumulation beyond the 5-digit display capacity
	Total – Indicates the total weight displays for 5-seconds or less
	Net – Indicates the scale is in Net mode; Tare weight has been subtracted from the gross weight
	Kilograms – Indicates weight display is in kilograms
	Pounds – Indicates weight display is in pounds
	Not applicable
	Main Display – Five-digit, 1.75" (44.5 mm) LCD display with programmable brightness control

Table 3-2. Annunciator Functions

## 3.2 Power

Press **POWER**  to turn the MSI-4260M on. The following displays in order:

- All LCD segments and LED annunciators turn on at full brightness as a display test
- Display brightness changes to the setting determined in the Display Menu
- The software version number displays
- The MSI-4260M is ready for use

## 3.3 Zero

**ZERO**  sets the zero reading of the scale. Press **ZERO**  to take out small deviations from zero when the scale is unloaded. See [Section 3.4](#) for zeroing (taring) a package or pallet weights.



*The scale digits display 0 (or 0.0 or 0.00, etc).*





*The backup memory in the MSI-4260M stores the zero reading and retains it even if the power fails.*

### Rules for Use

- Works in **GROSS** or **NET** mode
- Zeroing while in net mode zeros the gross weight causing the display to show a negative tare value
- The scale must be stable within the motion window; The scale will not zero if the stabilizer annunciator is off; The scale remembers that it has a zero request for 2-seconds; If a motion ceases within the motion window in that time, the scale zeros
- The scale accepts a zero setting over the full Range of the scale (NTEP and other Legal-for-Trade models may have a limited zero range); Zero settings above 4% of full scale subtracts from the overall capacity of the scale  
*Example: If 100 lb on a 1000 lb scale is zeroed, the overall capacity of the scale reduces to 900 lb, plus the allowed over-range amount.*

## 3.4 Tare

Tare is used to zero out a known weight such as a packing container or pallet and display the load in net weight.

- A tare value is entered by pressing **TARE** ; The tare function is defined as a Tare-In, Tare-Out operation
- The first press of **TARE**  stores the current weight as a tare value then the scale subtracts the tare value from the gross weight and changes the display to net mode; The next press of **TARE**  clears the tare value and revert the display to gross mode
- To view the gross weight without clearing the tare value, program the **USER**  to the Net/Gross function; The RF Rugged Remote Control or RF remote display can have a Net/Gross permanently available
- To tare and display the net weight, press **TARE** 



*The weight reading must be stable within the motion window for the tare function to work.*

*The scale digits display 0 (or 0.0 or 0.00, etc) and the weight mode changes to NET.*

*The backup memory in the MSI-4260M stores the tare reading and can restore it even if power fails.*

To clear the tare and revert to gross weight, press **TARE** . *Gr-055* displays.







- Only positive gross weight readings can be tared
- The  must be on indicating weight reading is stable
- Setting or changing the tare has no effect on the gross zero setting
- Taring reduces the apparent over range of the scale

*Example: Taring a 100 lb container on a 1000 lb scale, the scale overloads at a net weight of 900 lb (1000-100) plus any additional allowed overload (about 4% or 9 d).*

- The scale stores the tare value in non-volatile memory and is restored when power is cycled

### 3.5 User

The MSI-4260M has configurable user function key, **USER** , on the front panel that can be programmed to one of several functions. To set the user function key use the following steps:







1. Press and hold **USER**  and **POWER** . *Func 1* displays.
2. Press **TARE** . The currently set function displays.
3. Press **USER**  to scroll through the available functions.
4. Press **TARE**  when the desired function is displayed. *Func 2* displays.
5. Press **ZERO** . *SetorE* displays briefly and the display returns to **Weighing** mode.

#### Test Mode

For test mode information, see [Section 4.2.2 on page 11](#).

### 3.6 Menu Navigation

The following keys can be used when navigating through the MSI-4260M menus.

- Press **POWER**  to exit a menu without saving changes; *ErrCL* displays and unit returns to **Weighing** mode
- Press **ZERO**  to go back one level or to exit a menu and save changes, *SetorE* displays and unit returns to **Weighing** mode
- Press **USER**  to scroll through menu parameters and parameter settings
- Press **TARE**  to enter or select a menu parameter or parameter setting
- If a wrong value is entered, press **ZERO**  to step back one digit and press **TARE**  to change the digit





**If a function key does not work, the MSI-4260M is not set up to support the key.**

**For example, if **USER**  is set to Total, the Total mode must also be set up in the Setup menu.**

## 4.0 Setup

This section provides an overview of MSI-4260M Port-A-Weigh crane scale **Setup** menu and instructions.

### 4.1 Setup Menu

To enter into the MSI-4260M **Setup** menu, press **POWER**  and **USER**  simultaneously.

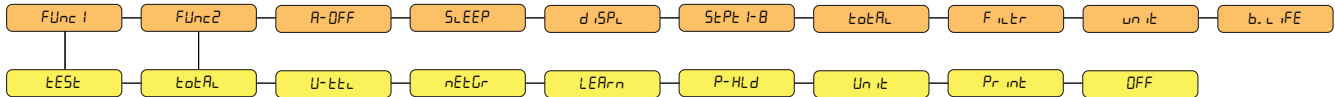

Figure 4-1. Setup Menu

Parameter	Setting	Description
FUnc 1 (Function 1) FUnc 2 (Function 2)	tEst	Test Display – See <a href="#">Section 4.2.2 on page 11</a>
	totAL	Total – See <a href="#">Section 4.2.3 on page 12</a>
	U-ttL	View Total – Function always available on the RF remote device ( <a href="#">Section 4.2.4 on page 12</a> )
	nEtGr	Function always available on the RF remote device ( <a href="#">Section 4.2.5 on page 12</a> )
	LEArn	Not applicable
	P-HLd	Peak Hold – See <a href="#">Section 4.2.6 on page 12</a> Function not available or non-functional in OIML R76 or NTEP HB44 modes
	Un it	Units – See <a href="#">Section 4.2.7 on page 12</a> Function not available or non-functional in OIML R76 and 1Unit modes
	Pr int	Print – See <a href="#">Section 4.2.8 on page 12</a>
R-OFF (Auto Off Time)	OFF	Prolongs battery life of scale by turning power off after the set time (in minutes) that the scale is not in use ( <a href="#">Section 4.3 on page 12</a> )
	15	
	30	
	45	
SLEEP (Sleep)	OFF	Time (in minutes) before unit enters sleep mode ( <a href="#">Section 4.4 on page 13</a> )
	5	
	15	
d.SPL (Display LCD Back-light Intensity)	Auto	Used to set the display back-light brightness ( <a href="#">Section 4.5 on page 13</a> )
	LO-1	
	LO-2	
	HI-1	
StPt 1-8 (Setpoints 1–8)	OFF	Used for warnings or process control ( <a href="#">Section 4.6 on page 14</a> )
	GrEARt	
	LESS	
totAL (Total Mode)	OFF	Accumulation of multiple weighments ( <a href="#">Section 4.7 on page 15</a> )
	tEtLn	
	R.LoAd	
	R.LASt	
Filter (Weight Filter)	LO	Allows the scale to adjust to situations where there may be movement ( <a href="#">Section 4.8 on page 16</a> )
	HI-1	
	OFF	
Un it (Weight Units)	Lb	Toggle units between pounds and kilograms Function not available or non-functional in OIML R76 and 1Unit modes ( <a href="#">Section 4.9 on page 16</a> )
	KG	
b.LiFE (Battery Life)	StAnd Long	Sets the options for standard or extended battery life ( <a href="#">Section 4.10 on page 16</a> )

Table 4-1. Setup Menu Parameters

## 4.2 Function User Keys

### 4.2.1 Set Function Key

The MSI-4260M has one user definable key on the front panel, that can be programmed to one of several functions. The additional function key is available on the optional RF Rugged Remote Control or RF remote display.

To set the function key use the following steps:

1. If the unit is turned off, press and hold **USER** then press **POWER**.  
If the unit is on, press **USER** and **POWER** simultaneously. *FUnc 1* displays.



**Note** *FUnc 1* is **USER** on the MSI-4260M or the F1 key on the connected RF remote device and *FUnc 2* would only be the F2 key on the connected RF remote device.

2. Press **TARE**. The current user key function displays.
3. Press **USER** to scroll through the available functions.
4. Press **TARE** when the desired function displays. *FUnc 2* displays.
5. Press **ZERO**. *StarE* displays, the unit exits setup and stores the settings.



**Note** Press **POWER** at any time to cancel the procedure.

### 4.2.2 Test

To perform a test, press **USER**, which is configured to **TEST**. The device LCD segments and LED annunciators flash momentarily as a display test. The display scrolls through the test parameters (Table 4-2). Other internal tests are also performed and if any test fails, an error code displays. See Section 7.1 on page 30 for information on error codes.

Parameter	Description
<i>SoFt</i>	Software – Displays the current weighing standard (Section 5.6.1 on page 24)
<i>StAnd</i>	Standby – Displays current weighing standard (Section 5.6.1 on page 24); Does not indicate Standby
<i>bAtt</i>	Battery – Displays battery information
<i>d. tESt</i>	Display Test – Tests the display of the unit, Every digit of the display flashes momentarily in order of 0–9 digits
<i>C-CAL</i>	C-Cal – Displays current calibration constant (C-CAL)

Table 4-2. Test Parameters

### Single Step Through Test Procedure

1. Press **USER** within 2-seconds of test start to enable a single step mode.
2. Press **USER** to scroll through the available test parameters.
3. Press **TARE** to start or display the individual tests.
4. Press **ZERO** to exist individual tests.
5. Press **ZERO** to exist from the test and return to **Weighing** mode.

### 4.2.3 Total

Set the total parameter to  $FUNc1$  (Function 1) for the MSI-4260M **USER** or  $FUNc2$  for the F2 key on a connected RF Rugged Remote Control or RF remote display.



**Note** The total mode must be programmed from the Setup menu before **USER** will function (Section 4.8 on page 16).

### 4.2.4 View Total

**USER** activates total weight display followed by the number of samples. Press **ZERO** to clear with total weight displayed.

### 4.2.5 Net/Gross

Switches the display between net and gross modes. Net weight is defined as gross weight minus a tare weight.

To switch between net mode and gross mode, press **USER** configured to NET/GROSS. This only works if a tare value has been established.

The operator can switch back to gross from net without clearing the tare value. Only clearing or setting a new tare changes the tare value held before switching into **Gross** mode.

**OIML Legal-for-Trade units only:** The **USER** or RF remote device **F-KEY** configured to Net/Gross is a temporary action only. The gross weight displays for 2-seconds then the display returns to the **Net** mode. The only way to return to permanent gross readings is to clear the tare (Section 3.4 on page 8).

### 4.2.6 Peak Hold

Peak hold only updates the display when a higher peak weight reading is established.

The peak hold function uses a high speed mode of the A/D converter allowing it to capture transient weights at a far higher rate than typical scales. Peak hold is cleared and re-enabled with the **USER** or RF remote device **F-KEY**.

Peak hold is not available on NTEP or OIML Legal-for-Trade certified scales.

### 4.2.7 Unit

Unit can be changed in two ways:

- Program a user function key to units
- Change the units with the **Setup** menu



**Note** Unit switching is not available on OIML certified Legal-for-Trade scales.

### 4.2.8 Print

If a print option is installed this menu choice appears. The setup of the print function is covered in the **Print RF** menu.

## 4.3 Auto-Off

The **A-OFF** feature prolongs the battery life by powering off the unit when not in use. When a button is pressed or the detected load is in motion exceeding 10 d, the time limit is reset. When disabled, the unit remains on and only turns off when **POWER** is pressed or the batteries run out. Use the following steps to set the Auto-Off function:

1. If the unit is turned off, press and hold **USER** then press **POWER**.  
If the unit is on, press **USER** and **POWER** simultaneously.  $FUNc1$  displays.
2. Press **USER** to scroll to **A-OFF**.
3. Press **TARE** the current **A-OFF** time displays.
4. Press **USER** to scroll through the available times.
5. Press **TARE** when the desired time displays. **SLEEP** displays.
6. Press **ZERO** to exit setup and store the settings.



**Note** Press **POWER** at any time to cancel the procedure.

## 4.4 Sleep

The **Sleep** parameter reduces power consumption by automatically turning off the display during periods of inactivity. While in the **Sleep** mode, the green acknowledge annunciator blinks at a 1-second rate to indicate the unit is in **Sleep** mode. To wake up the unit, either a button must be pushed (MSI-4260-M front panel or connected RF remote device) or the weight must change by 5 d or more.



**Note** *Sleep must be set to less time than the Auto-Off timer.*

1. If the unit is turned off, press and hold **USER** then press **POWER** .  
If the unit is on, press **USER** and **POWER** simultaneously. *Func 1* displays.
2. Press **USER** to scroll to the *SLEEP* function.
3. Press **TARE** . The current *SLEEP* time displays.
4. Press **USER** to scroll through the available times.
5. Press **TARE** when the desired time displays.
6. Press **ZERO** to exit **Setup** and store the settings.



**Note** *Press **POWER** at any time to cancel the procedure.*

## 4.5 Display Backlight Brightness

The **Display** menu is used to set the display backlight brightness. There are four fixed brightness settings and one automatic light sensing brightness setting.

Auto setting automatically detects the ambient light and adjusts the brightness of the LCD backlight accordingly. Bright ambient light causes the LCD back-light to turn off. The LCD back-light brightness adjusts based on ambient light.

There are four fixed brightness settings, **LO-1**, **LO-2**, **HI-1** and **HI-2**. Lower brightness settings increase battery life.

1. If the unit is turned off, press and hold **USER** then press **POWER** .  
If the unit is on, press **USER** and **POWER** simultaneously. *Func 1* displays.
2. Press **USER** to scroll to the *DISPL*.
3. Press **TARE** . The current setting displays.
4. Press **USER** to scroll through the available settings.



**Note** *The display backlight brightness changes when each setting displays.*

5. Press **TARE** when the desired setting displays. *SETE 1* displays.
6. Press **ZERO** to exit **Setup** and store the settings.



**Note** *Press **POWER** at any time to cancel the procedure.*

## 4.6 Setpoints

The MSI-4260M supports eight user programmable setpoints. Common uses of setpoints are for warnings or process control. Setpoints 1-3 are visible on the device and have LED outputs that can be setup in the **RF** menu (Section 6.0 on page 25). Setpoints 4-8 can only be used by connecting a compatible RF remote control or RF remote display.



Figure 4-2. Setpoint LEDs

The MSI-4260M has an audible output option that is triggered by Setpoint 1. Contact Rice Lake Weighing Systems for other setpoint output options. To set the setpoint:

Setpoint	Description
<b>Setpoint Mode</b>	
GRGRT	Great – Indicates the setpoint triggers when the weight exceeds a set value
LESS	Less – Indicates the setpoint triggers when the weight is less than a set value
<b>Setpoint Weight Type</b>	
NETGR	Net/Gross – Responds to net or gross weight
GROSS	Gross – Responds to gross weight regardless of the display
TOTAL	Total – Responds to the totaled weight
T-CNT	Total Count – Responds to the total count (number of samples)
LF-CNT	LF Count – Responds to the number of times the weight has exceeded 25% of capacity

Table 4-3. Available Setpoint Settings

- If the unit is turned off, press and hold **USER** then press **POWER**.  
If the unit is on, press **USER** and **POWER** simultaneously. *Func 1* displays.
- Press **USER** to scroll to the desired *Setpt 1 - 8*.
- Press **TARE**. The current *Setpt* mode displays.
- Press **USER** to scroll to the *Setpt* mode desired.
- Press **TARE**. The current *Setpt* weight type displays.
- Press **USER** to scroll to the desired weight type.
- Press **TARE**. The current *Setpt* weight value displays.
- Press **USER**. The first digit blinks.
- Press **USER** to scroll to the desired number.
- Press **TARE**. The second digit blinks.
- Repeat [Step 8](#) through [Step 10](#) until the desired value displays.



**Note** To enter a decimal point, press **POWER** while the digit is blinking. To correct a digit, press **ZERO**.

- Press **TARE**. The value stops blinking and the next **Setup** menu item displays.
- Repeat [Step 2](#) through [Step 12](#) to set all the setpoints to be used.
- Press **ZERO** to exit setup and store the settings.



**Note** Press **POWER** at any time to cancel the procedure.

## 4.7 Total



For the accumulation of multiple weighments, the **Total** function used the displayed load, so gross and net readings can be added into the same total.

There are four modes of totalizing: manual and three auto modes. **Manual** mode requires the **TOTAL** key be pressed with the weight on the scale. The weight is added to the previously accumulated value. This assures that a weight on the scale is only added to the total once.

Both the manual and three auto total modes require that the weight on the scale return below 0.5% (relative to full scale) of **Gross** or **Net Zero** before the next weighment can be added. Applied weight must be  $\geq 1\%$  of full scale above **Gross Zero** or **Net Zero** before it can be totaled.

### 4.7.1 Manual Total

**USER**  under the **Manual Total** mode, **TTOn** (Total On) functions in this manner:

- **Weight is greater than 1% of capacity and has not been totaled** – Pushing **USER**  adds the current weight to the total weight; The displayed weight blinks to indicate the weight was accepted; The **Total** annunciator; Lights and the Total weight displays for 5-seconds then the number of samples displays for 2-seconds
- **Current weight has been totaled** – Pushing **USER**  displays the total weight for 5-seconds (View Total) without changing the total value; The **Total** annunciator lights while the total weight displays; After 5-seconds of the total weight displaying, the number of samples displays for 2-seconds
- **Weight is less than 1% of capacity** – **USER**  functions as View Total only and functions as View Total until the 1% threshold is exceeded to allow the next addition to the total value



### 4.7.2 Auto Total

**USER**  under the **Auto Total** mode functions as Auto Total On / Auto Total Off.











Auto Mode has three variations which are programmed in the **Setup** menu:

- **R. Load (AutoLoad)** – Ensures any settled load above the **Rise above** threshold is automatically totaled; The scale must fall below the **Drop below** threshold before the next total is allowed
- **R. Last (AutoLast)** – Mode takes the last settled weight to auto total with; The total occurs only once the scale goes below the threshold; This allows the load to be adjusted without a total occurring; Once the load is removed, the scale uses the last settled reading for total
- **R. High (AutoHigh)** – Uses the highest settled reading; This is useful for loads that cannot be removed all at once



**Note** *Total Mode does not function while the scale is in motion, make sure   is on. If the system fails to achieve stable readings, increase the filter setting or increase the size of the scale division (d) in the Init Cal procedure.*

### 4.7.3 Set Total Mode

1. If the unit is turned off, press and hold **USER**  then press **POWER** .  
If the unit is on, press **USER**  and **POWER**  simultaneously. **Func 1** displays.
2. Press **USER**  to scroll to **TLRL**.
3. Press **TARE** . The currently saved total mode displays.
4. Press **USER**  to scroll through the choices.
5. With choice displayed, press **TARE**  to select. **FLTR** displays.
6. Press **ZERO**  to save and exit to Weighing mode or press **USER**  to continue to another **Setup** menu item.

## 4.8 Filter

Changing the filter settings allows the scale to adjust to situations where there is a lot a movement in the structure. If the reading is not stable, it can often be improved by increasing the filter setting. Settling time is longer as the filter setting is increased. However, the MSI-4260M employs algorithms that speed up large weight changes while still controlling vibration even with high filter settings.

Use the following steps to set up filtering:

1. If the unit is turned off, press and hold **USER** then press **POWER**.  
If the unit is on, press **USER** and **POWER** simultaneously. *Func 1* displays.
2. Press **USER** to scroll to *FILTR*.
3. Press **TARE**. The currently saved total mode displays.
4. Press **USER** to scroll through the choices.
5. With choice displayed, press **TARE** to select. *Unit* displays.
6. Press **ZERO** to save and exit to **Weighing** mode or press **USER** to continue to another **Setup** menu item.

## 4.9 Unit

1. If the unit is turned off, press and hold **USER** then press **POWER**.  
If the unit is on, press **USER** and **POWER** simultaneously. *Func 1* displays.
2. Press **USER** to scroll to *Unit*.
3. Press **TARE** to enter *Unit*.
4. Press **USER** to toggle between lb and kg.
5. With the desired choice displayed, press **TARE** to select.
6. Press **ZERO** to save and exit to weighing mode.

## 4.10 Battery Life

1. If the unit is turned off, press and hold **USER** then press **POWER**.  
If the unit is on, press **USER** and **POWER** simultaneously. *Func 1* displays.
2. Press **USER** to scroll to *b. LIFE*.
3. Press **TARE**. The currently saved total mode displays.
4. Press **USER** to toggle between the choices.
5. With choice displayed, press **TARE** to select. *Func 1* displays.
6. Press **ZERO** to save and exit to weighing mode or press **USER** to continue to another **Setup** menu item.

## 5.0 Calibration

This section provides an overview of MSI-4260M Port-A-Weigh Crane Scale calibration instructions.

The MSI-4260M is calibrated using the certified test weights. It is required that the weight used is at least 10% of full capacity in order to achieve rated accuracy. For example, use at least a 500 lb test weight to calibrate a 5000 lb capacity scale. Although a single span point is usually adequate for rated accuracy, the MSI-4260M supports Multi-Point calibration with up to four span points plus zero.

When adequate test weights are not available, the MSI-4260M can be re-calibrated using a calculated calibration constant which is referred to as C-Cal. To use C-Cal, a previously generated C-Cal number must be known.

There are three kinds of calibration:

- **Standard Calibration** – Used for maintenance and routine calibration
- **Initial Calibration** – Used to set up both the capacity and resolution (d) of the scale; It differs from Standard Calibration only in the initial steps; The initial calibration is performed after a calibration reset which completely erases the calibration and setup memory
- **C-Cal** – If the last calculated C-Cal values is known, the MSI-4260M can be calibrated without weights

### 5.1 Calibration Switch Access

Use the following steps to access the calibration switch on the MSI-4260M if calibrating the unit using either the standard calibration or the C-Cal calibration.

1. Remove the hex seal screw from the MSI-4260M.

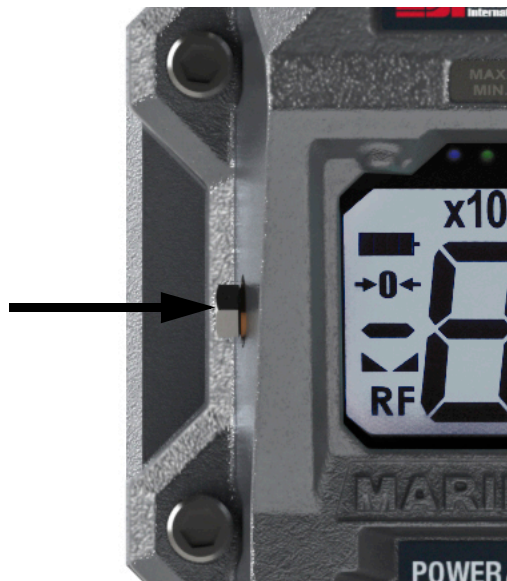

Figure 5-1. Calibration Switch Seal Screw

2. Using a small screwdriver, press the Cal switch located behind the hex seal screw (Figure 5-1).  $\bar{L}R\bar{L}$  displays.

## 5.2 Calibration Menu

See the following information for standard calibration procedure.

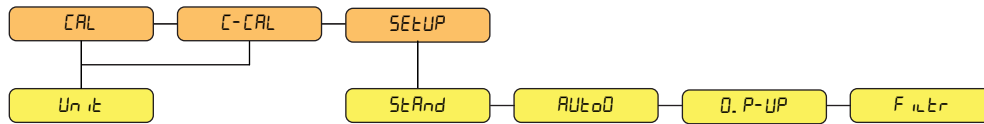

Figure 5-2. Calibration Menu

















Menu	Parameter	Description
CAL (Calibration)	Unit	Weight Units – Toggle units between pounds and kilograms
C-CAL (C-Cal)		
SETUP (Setup)	Stand	Software – Selections: IndUS, hb-44, r-7E, Unit (Section 5.6.1 on page 24)
	Auto	Auto Zero Maintenance – Allows the scale to adjust the zero reading to the center-of-zero, which is defined as the weight reading within 1/4 d of zero; Continuously adjusts zero to maintain the center-of-zero Selections: On, Off
	D. P-UP	Zero Power Up – Selections: On, Off
	Filter	Weigh Filter – Allows the scale to adjust to situations where there may be movement Selections: On, Off

Table 5-1. Calibration Menu Parameters

### 5.2.1 Standard Calibration

See the following information for standard calibration procedure.

Use the following steps to calibrate the MSI-4260M using the standard calibration procedure.

1. Remove the hex seal screw from the MSI-4260M using the steps from [Section 5.1 on page 17](#) and CAL displays.
2. Press **TARE** , Unit displays.
3. Select the weight unit ([Table 5-1](#)) then press **TARE** , CAP displays.
4. Press **TARE** , Unit displays.
5. Press **TARE** , when the scale becomes motionless, a blinking □ displays.
6. If the scale is in range PASS displays then Load displays.
7. Load the scale with a test weight (for a single span point calibration, a test weight of more than 20% of capacity or more is recommended).
8. Press **TARE** , The current capacity flashes on the display. If loading the scale with the capacity weight, skip to [Step 11](#).
9. Press **USER**  if using a calibration weight other than capacity. The displays far left digit blinks indicating a number should be entered.
10. Press **USER**  to scroll the numbers and **TARE**  to enter each digit.  
 Example: Enter 2500 lb on a 5000 lb capacity scale.  
 Press **USER**  two times for the leftmost blinking digit, press **TARE**  to save that digit selection.  
 Press **USER**  five times for the next blinking digit, press **TARE**  to save that digit selection.  
 Press **TARE**  to save that digit selection.  
 Press **TARE**  to save the next digit selection. 2500 displays.
11. Press **TARE**  to save the weight entry. If the cal value is within limits, PASS is briefly displayed then Load2.
12. Press **TARE**  if more cal points are desired or **ZERO**  if a single point cal is needed.

13. Load the scale the next test weight and press **TARE** if the weight value is acceptable.
14. Press **USER** to scroll through digit choices and press **TARE** to enter the calibration weight value.
15. Press **TARE** again to complete the calibration span point. If the cal value is within limits, *PASS* is briefly displayed then *L0Rd3* or *L0Rd4* displays.
16. Press **TARE** to enter an additional span point or **ZERO** if finished and the display shows *CRL d* to indicate that the calibration was successful.
17. Press **TARE** and the display flashes *C-CAL* followed by the *C-CAL* number.
18. Press **ZERO** to store the calibration and *SETUP* displays.
19. Press **ZERO** to exit the calibration menus and start up the standard weight display.
20. Replace the hex seal screw that was removed in [Section 5.1 on page 17](#).

### 5.2.2 Auto Zero Maintenance

The MSI-4260M employs an autozeroing maintenance mechanism to adjust the zero reading to the center-of-zero (COZ). COZ is defined as the weight reading is within 1/4 'd' of zero. AZM continuously adjusts zero to maintain COZ. It is recommended that AZM is on to maintain the highest accuracy. There are circumstances when it should be turned off. This occurs when minor variations of weight occur while picking up scale attachments and the variations fall within the AZM capture window. The AZM capture window (usually 1 'd') and capture time (usually 8-seconds) can be adjusted by Rice Lake Weighing Systems to meet custom requirements. The settings of AZM are dictated in Legal-for-Trade standards and cannot be adjusted.

Use the following steps to set up the auto zero maintenance.

1. Remove the hex seal screw from the MSI-4260M using the steps from [Section 5.1 on page 17](#) and *CRL* displays.
2. Press **USER** to scroll to *SETUP*.
3. Press **TARE** to enter the *CRL* setup menu. *SEtRnd* displays.
4. Press **USER** to scroll to the *AUte00* menu. *AUte00* displays.
5. Press **TARE** to enter the *AUte00* menu. The current setting (blinking) displays.
6. Press **USER** to toggle between *On* or *OFF*.
7. Press **TARE** to set the auto zero. *SEtRnd* displays.
8. Press **ZERO** twice to exit setup and store all changes. *St0rE* displays.

### 5.2.3 Zero Power Up

This feature will cause the unit to automatically zero after the unit is turned on. Default is *OFF*.

1. Remove the hex seal screw from the MSI-4260M using the steps from [Section 5.1 on page 17](#) and *CR* displays.
2. Press **USER** to scroll to *SETUP*.
3. Press **TARE** to enter the *CR* setup menu. *STAND* displays.
4. Press **USER** to scroll to *0. P-UP*.
5. Press **TARE**. The current setting is displayed.
6. Press **USER** to toggle between *On* or *OFF*.
7. When desired value is displayed, press **TARE**. *FILTER* displays.
8. Press **USER** twice to save settings. *STORE* displays briefly and exits setup.

### 5.2.4 Filter

Changing the filter settings allows the scale to adjust to situations where there is a lot a movement in the structure.

If the reading is not stable, it can often be improved by increasing the filter setting. Settling time will be longer as the filter setting is increased. The MSI-4260M employs algorithms that speed up large weight changes while still controlling vibration even with high filter settings. Selections are *OFF*, *L0* and *H1*.

1. Remove the hex seal screw from the MSI-4260M using the steps from [Section 5.1 on page 17](#) and *CR* displays.
2. Press **USER** to scroll to *SETUP*.
3. Press **TARE**. *STAND* displays.
4. Press **USER** to scroll to *FILTER*.
5. Press **TARE**. The current setting is displayed.
6. Press **USER** to scroll to desired setting.
7. When desired value is displayed, press **TARE**. *STAND* displays.
8. Press **USER** twice to save settings. *STORE* displays briefly and exits setup.

## 5.3 Initial Calibration

Use this procedure only if the capacity and count-by (d) needs to be modified. The initial steps of the initial calibration will erase user setup and previous calibrations.

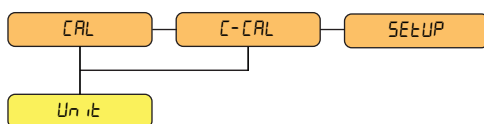















Figure 5-3. Initial Calibration Menu

Menu	Parameter	Description
CAL (Calibration)	Units	Weight Units – Toggle units between pounds and kilograms
C-CAL (C-Cal)		

Table 5-2. Initial Calibration Menu Parameters

Use the following steps to calibrate the MSI-4260M using the initial calibration procedure.

1. Turn the MSI-4260M off.
2. Remove the hex seal screw from the MSI-4260M using the steps from [Section 5.1 on page 17](#).
3. Press and hold the **CAL** switch and **POWER** switch on the unit simultaneously until the display reads *rESEt*.
4. Press and hold **TARE**  to reset the calibration constants. *SEtUP* displays.
5. Press **TARE**  to complete the reset and *CAL* displays.
6. Press **TARE**  to start the initial calibration then *Units* displays.
7. Press **TARE**  to select the calibration unit.
8. Press **USER**  to choose between lb and kg then press **TARE** .
9. Press **TARE**  to enter the capacity setting. A capacity of 5000 is the initial value and should not be set no higher than the load cell rated capacity.
10. Press **USER**  to change the capacity and the first digit on the display blinks.
11. Press **USER**  to scroll through the numbers then press **TARE**  when the desired number is shown.
12. Press **TARE**  to store the capacity value. *d* displays.
13. Press **TARE**  to begin the scale divisions.
  - Press **USER**  to scroll through the recommended scale divisions.
14. Press **TARE**  to select the desired scale division. *Units d* displays, indicating that the scale is ready for calibration.
15. Follow standard calibration procedure to calibrate the MSI-4260M (begin with [Step 2 on page 18](#)).

## 5.4 Guidelines for Capacity and Resolution

Crane scales are subject to forces that other scales are not subject. Many bridge cranes, hoist cranes and mobile cranes lack rigidity and tend to bounce or swing when loads are lifted. Rice Lake Weighing Systems recommends the resolution is within the 1:2000 to 1:3000 range. Stability improvements can be achieved by increasing the filtering. Do not program the resolution to a value that is greater than needed. If the MSI-4260M display is not stable, it is recommended that the resolution is reduced or the filtering increased.

Due to Legal-for-Trade requirements and general scale design criteria, the weight must be stable for certain features to work:

- ZERO – The weight must be stable to be zeroed
- TARE – The weight must be stable to be tared
- TOTAL – The weight must be stable to be added to the total registers

One way to improve the stability is to increase the filtering, at the risk of increasing settling time.

The other is to increase the *d* (reduce resolution). The third way is to increase the **Motion Window**. The MSI-4260M defaults to  $\pm 1$  d as a motion window. It can be changed at Rice Lake Weighing Systems to a higher value if desired. Often  $\pm 3$  d is chosen for bridge cranes as these tend to have a lot of bounce to them. This of course carries an accuracy penalty adding  $\pm 3$  d to the total accuracy of the scale if the zero or tare operation happens to capture the weight in a valley or peak.

Setting capacity is dictated primarily by the capability of the load cell. Rice Lake Weighing Systems supplies the MSI-4260M in many capacities.



**Note**

***Never set the capacity of the scale higher than the rating of the load cell. Capacity should always be set to the capacity listed on the front of the scale. Setting capacity below this may reduce scale accuracy and setting capacity above this value could expose the scale to loads beyond its design limits.***

Due to excellent linearity of the MSI S-Beam load cell, it is acceptable to set lower capacities to better match the crane the MSI-4260M is used on. For example, if the hoist is rated for 3000 lb, use an MSI-4260M and reset the capacity to 3000 lb so that the scale indicates overload at 3000 lb instead of 5000 lb. Derating as much as 50% of the capacity is usually acceptable, but the scale may be less stable if the 'd' is decreased.















Due to kg to lb conversions, the capacity of all MSI-4260M systems are rated approximately 20% higher than the rated capacity in pounds. This allows the kg capacity to be exactly one-half the number of the lb capacity.

## 5.5 C-Cal Calibration

When adequate test weights are not available, the MSI-4260M can be calibrated using a programmed constant calibration which is referred to as C-Cal. To use C-Cal, a C-Cal number must be known from a previous calibration. When a calibration is performed with test weights, a new C-Cal is generated. C-Cal can be used when the electronics are replaced to get an approximate calibration that may be suitable for non L-F-T applications.



C-Cal reduces slightly the absolute accuracy of the system if the electronics are replaced or a new load cell is installed and is intended for non-critical use only. Legal-for-Trade installations require that the MSI-4260M is calibrated using test weights. If a system was originally multi-point calibrated, the C-Cal calibration erases the additional span points, as C-Cal is only a two point calibration (zero and span at 10% of capacity).

Use the following steps to perform a C-Cal calibration.



1. Remove the hex seal screw from the MSI-4260M using the steps from [Section 5.1 on page 17](#).
2. Press **USER**   to scroll to the **C-Cal** menu selection and then **← CAL** displays.
3. Press **TARE**   to start C-Cal procedure. **UNLD** displays, indicating all weight should be removed from the hook.
4. Press **TARE**   to set the zero calibration point. A flashing **0** displays.
5. If the zero is in range, the scale briefly displays **PASS**. **← CAL** displays.
6. Press **TARE**   and the MSI-4260M is ready for numeric entry of the C-Cal value.
7. Press **USER**   to enter the C-Cal value. The far left digit flashes, indicating that number should be entered.
8. Press **USER**   to scroll the numbers and **TARE**   to enter each digit.



*Example: Enter 2500 lb on a 5000 lb capacity scale.*



*Press **USER**   two times for the leftmost blinking digit, press **TARE**   to save that digit selection.*





*Press **USER**   six times for the next blinking digit, press **TARE**   to save that digit selection.*

*Press **USER**   for the next blinking digit.*

*Press **TARE**   to save that digit selection.*

*Press **USER**   for the next blinking digit.*

*Press **TARE**   to save that digit selection. **2500** displays.*

9. Press **TARE**   to save the C-Cal value. The display reads **PASS** followed by **CAL' d**.
10. Press **ZERO**  to exit **C-Cal** menu and press **ZERO**  again to store the calibration and return to **Weighing** mode and the **STORE** briefly displays) or press **POWER**  to cancel the calibration and return to the **Weighing** mode (**FRNC** briefly displays).

## 5.6 Calibration Setup Menu

The **Calibration Setup** menu contains two additional items beyond Calibration:

- **Standard** menu
- **Auto Zero Maintenance** menu (**Auto0**)











In addition, more menus will appear that are transferred from the main **Setup** menu when Legal-for-Trade settings are used.

### 5.6.1 Standard Menu

Selection	Description
Industrial (Industrial)	This is the most common setting for the MSI-4260M; With the Industrial standard, you have full range zero, access to units switching, filters, and peak hold
HB-44 (Handbook 44)	Sets the scale to enable only approved features per the NTEP HB-44 rules and regulations; Access is denied to Peak Hold, and the zero range may be limited; The <b>Filter</b> menu is moved to the <b>Cal Setup</b> menu, so filters are only accessible through the Cal Seal
R-76 (R-76)	Sets the scale to enable only approved features per OIML R-76; Only kg weight units are available; The zero range is limited to 4% (-1–3% relative to Calibrate zero); Net/Gross function is temporary; When Net weight is established, pushing an F-key set for Net/Gross will cause a maximum 5 second display of the Gross weight; Tare must be cleared to display Gross weight constantly; Other metrological aspects are changed to meet R-76 requirements
One Unit (One Unit)	The one unit Standard is exactly the same as Industrial, except units switching is inhibited; This is useful for Metric only countries; Another use of the One Unit standard is to allow the scale to be calibrated in units other than lb or kg, since conversions are eliminated; Contact Rice Lake Weighing Systems for more information on the Standards settings

Table 5-3. Standard Menu Selections

Use the following steps to set up a Legal-for-Trade standard settings.

1. Remove the hex seal screw from the MSI-4260M using the steps from [Section 5.1 on page 17](#) and **LR** displays.
2. Press **USER**   twice to scroll so **SEtUP** displays.
3. Press **TARE**   to enter the **Calibration Setup** menu. **SEtUP** displays.
4. Press **TARE**   to enter the **Standard** menu. The current standard setting displays.
5. Press **USER**   to scroll to the desired standard.
6. Press **TARE**   to set the standard. **Auto0** displays.
7. Press **ZERO**  twice to exit setup and store all changes. **SEtUP** displays.

## 6.0 Communications Setup

This section provides an overview of MSI-4260M Port-A-Weigh Crane Scale communications setup instructions.

The MSI-4260M can communicate with peripheral devices using RS-232, 802.15.4, or 802.11/b,g WiFi.

Rice Lake Weighing Systems recommends the use of an RF receiver with RS-232 cable output for applications to gather weight data due to the potential hazard of a connected cable hanging from the scale. Due to the difficulty of dangling RS-232 cables from a hanging crane scale, the RF options are more commonly used for gathering weight data. The RS-232 port located on the right side of the MSI-4260M is useful for setup and calibration using a computer and ScaleCore Connect Software. (operation is detailed in the ScaleCore Connect manual).

For RF operation, the MSI-4260M uses an 802.15.4 transceivers to communicate between Model 8000 RF remote display or other RF devices. 802.15.4 operates in the 2.4GHz ISM band and does not require the end user to obtain a license. 802.15.4 can coexist with other 2.4GHz systems if caution is taken to isolate antennas at least 10' (3 M) from the Crane Scales and RF receives. MSI-8000 based RF systems are peer to peer. For multiple scale connections, the MSI-8000 or other RF receiver acts as the network coordinator. Also available is the 802.11 Wi-Fi option for communicating directly to a standard RF access point.

For all devices that must interconnect, the RF Channel and Network ID must match. The ScaleCore ID must be unique. The MSI-4260M or other RF equipment that is a weight data source should be set to a ScaleCore ID of 0. If other devices are added, they can be added in sequence.

### 6.1 Communications Menu

To access the **Communications** menu, press **TARE** and **USER** at the same time. *Print* displays.

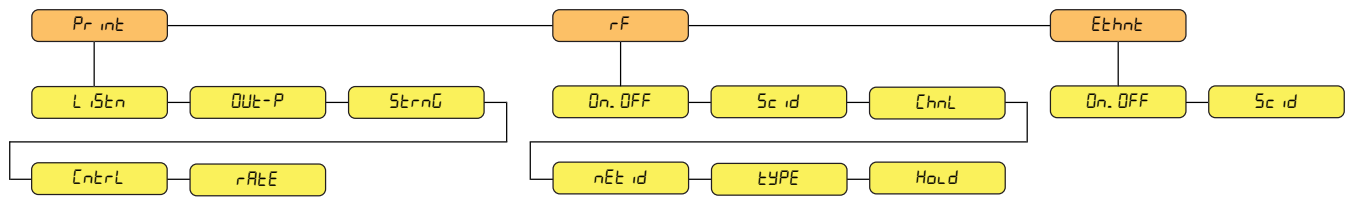

Figure 6-1. Communications Menu

Menu	Parameter	Description
<i>Print</i> (Print)	<i>L iStn</i> (Listen)	Select a value 0–9 to assign an value for the printer to listen for
	<i>OUt-P</i> (Output)	Select the output type: <i>Port0</i> , <i>rF</i> or <i>Port2</i>
	<i>StErnG</i> (String)	Select a value 0–9 to assign a string value.
	<i>Cntrl</i> (Control)	Select: <i>USER</i> , <i>LoAd</i> , <i>Cont</i> , <i>OFF</i>
	<i>rAtE</i> (Rate)	Select a value 0–9 to assign an print rate
<i>rF</i> (Remote Frequency)	<i>On. OFF</i> (On/Off)	Select On or Off to turn on or off the radio frequency; Effect continuous mode only
	<i>Sc id</i> (ScaleCore ID)	Displays the current scale ID; Select a value 0–254, (20-30), to assign an radio frequency ID to the scale
	<i>Chnl</i> (RF Channel)	Displays the current radio frequency channel; Select a value 12–23 to assign the radio frequency channel
	<i>nEt id</i> (Network ID)	Displays the current net ID; Select a value 0–999999 to assign a network ID
	<i>tYPE</i> (Type)	Select <i>2bEE</i> or <i>DEtEr</i>
<i>Ethnt</i> (Ethernet)	<i>On. OFF</i> (On/Off)	Select On or Off to turn on or off the Ethernet
	<i>Sc id</i> (Scale ID)	Displays the current scale ID; Select a value 0–9 to assign an Ethernet ID to the scale

Table 6-1. Communication Menu Parameters

### 6.1.1 Printer and Serial Output Setup

The RS-232 communications port is capable of outputting load data. All of the RF linked weight device weight modes are available in user formatted form.

The communications port settings reside only in the MSI-4260M and are independent of any print settings in connected RF Rugged Remote Control or RF remote display.

For printer and serial output setup, see the following information:

#### Printer Output (OUT-P)

Use the following steps to set up the printer output.

1. Press **TARE** and **USER** at the same time. *Print* displays.
2. Press **TARE**. *Unit* displays.
3. Press **TARE**. The current setting flashes.
4. Press **TARE**. *OUT-P* displays.
5. Press **TARE**. The current setting flashes.
6. Press **USER** to toggle between *Port0* and *RF*.
7. When the desired setting displays, press **TARE**. *Strn0* displays.
8. Press **TARE** to enter.
9. Enter the number using **USER** to scroll through numbers and **TARE** to set the string number desired.
10. When set, press **TARE** again. *cntrl* displays.
11. Press **TARE** to enter. Current setting flashes.
12. Press **USER** to scroll through the settings.
13. When desired setting displays, press **TARE**. *rRE* displays.

### Control Mode (Ctrl) (Cntrl)

The control mode program is what controls the MSI-4260M to print. To access the control mode parameter, see the following information:

1. To access the **Communications** menu, press **TARE** and **USER** at the same time. *Print* displays.
2. Press **TARE** to enter *Print*. *Load* displays.
3. Press **USER** to scroll to **Cntrl**.
4. Press **TARE** to edit the control mode parameter. The user can select three control modes (Table 6-2).

Mode	Description
USER (User)	Printing is controlled by the operator selecting <b>USER</b> ; Function 1 must be set to print mode (Section 4.2.1 on page 11)
LOAD (Load)	One print occurs when a stable load is read; The scale must then return to near zero before another print occurs <b>NOTE: Other configurations of load are available using the ScaleCore Connect software. Load configurations can be downloaded from <a href="http://www.ricelake.com">www.ricelake.com</a></b>
CONTINUOUS (Continuous)	The MSI-4260M continuously outputs the data at a rate specified in the rate parameter (up to 65,535-seconds); Setting the interval to 0 sets an interval as fast as the system can go
OFF (Off)	Printing is disabled; Power consumption is lower with the print off

Table 6-2. Control Modes

### Standard Print Strings

Commands that can be used to format gross, net and print formats are shown below.

Command	Description
<T>	Load data
<U>	Units
<M>	Load mode (lb/kg)
<CRLF>	Carriage return line feed
<SP>	Space

Table 6-3. Standard Print Strings Commands

String No.	When Used	Description
1	Current load	Fixed output length: 16; Leading zeros suppressed except for the least significant digit (LSD) <TTTTTT><SP><UU><SP><MMMMM><CRLF>
2	Net load	Fixed output length: 16; Leading zeros suppressed except for the LSD <TTTTTT><SP><UU><SP>NET<SP><SP><CRLF>
3	Gross load	Fixed output length: 16; Leading zeros suppressed except for the LSD <TTTTTT><SP><UU><SP>GROSS<CRLF>
4	Tare Weight	Fixed output length: 16; Leading zeros suppressed except for the LSD <TTTTTT><SP><UU><SP>TARE<CRLF>
5	Total Weight	Fixed output length: 16; Leading zeros suppressed except for the LSD <TTTTTT><SP><UU><SP>TTL<CRLF>
6	Number of Samples Totaled	Fixed output length: 16; Leading zeros suppressed except for the LSD <SP><SP><SP><SP><SP><SP><SSSSSS><SP><T-CNT><SP><CRLF>
7	Current Weight Mode	Net, Gross, Peak, and others; <SP><MMMM><CRLF>
8	Carriage Return/Line Feed	Used to add a space between print records; <CRLF>
9		

Table 6-4. Standard Print Strings

Combinations of the standard print strings can be entered in the string number entry screen.

*Example: To get a NET, GROSS, TARE printout with a space between records, enter 2349.*



**The ScaleCore Connect application can also be used for custom output strings, see the ScaleCore Connect Software Manual (PN 185725), for details. The ScaleCore Configuration Management Program (ScaleCore Connect) application can be downloaded from [www.ricelake.com](http://www.ricelake.com).**

The serial output is configured as 9600 baud, Xon/Xoff handshaking, no hardware handshaking, 1 stop bit, no parity. Other baud rates are possible by special order only.

### 6.1.2 RF Network Menu Setup

The red LED annunciator on the right represents standby mode is active when the scale is turned off. Standby is enabled if the radio is enabled and the scale is turned off. Radio remains powered when the scale is powered off, reducing battery life, but allows for the scale to be remotely turned on by the RF remote control.



Figure 6-2. Standby LED

Menu	Parameter	Description
rF (Remote Frequency)	On. OFF (On/Off)	Select On or Off to turn on or off the radio frequency; Effect continuous mode only
	Scale ID (ScaleCore ID)	Displays the current scale ID; Select a value 0–254, (20–30), to assign an radio frequency ID to the scale
	Channel (RF Channel)	Displays the current radio frequency channel; Select a value 12–23 to assign the radio frequency channel
	Net ID (Network ID)	Displays the current net ID; Select a value 0–999999 to assign a network ID
	TYPE (Type)	Select <i>2bEE</i> or <i>0tHEr</i>
	Hold (Hold)	Select <i>OFF</i> or <i>On</i> ; Allows for the scale to be turned on remotely when used with the RF remote device

Table 6-5. RF Network Parameters

- To access the **Communications** menu, press **TARE** and **USER** at the same time. *Prnt* displays.
- Press **USER** to scroll to *rF*.
- Press **TARE** to edit the *rF* parameters.

The MSI-4260M uses 802.15.4 transceivers to communicate with a compatible RF remote control or RF remote display.

The MSI-4260M uses three numbers to establish a network. Table 6-6 lists out the three elements used in setting up a network.

Element	Description	Recommended Number Range
ScaleCore ID	This number is used to identify each ScaleCore device in a Piconet; It has a range of 0–254 and must not be duplicated within the same RF Channel; For the MSI-8000 as network coordinator, Rice Lake Weighing Systems recommends a number for the MSI-4260M from 0-3 if multiple units will be connected to the MSI-8000; If a single MSI-4260M is used then any number up to 254 is acceptable	0–3
RF Channel	Establishes the base network that all interconnected devices must match; This number must be in the range of 12–23	12–23
Network ID	This is a 64 bit number that all interconnected devices must match; The MSI-4260M limits this number to a max of 5 digits for a range of 0–99999; Do not use a small number here to help avoid other 802.15.4 networks that default to a Network ID of 0	Maximum of six digits, a range of 0–99999

**For all devices that must interconnect, the RF channel and network ID must match. The ScaleCore ID must be unique. The crane scale that is the weight source should be set to a ScaleCore ID of 0. If other source devices are added, they can be added in sequence.**

Table 6-6. Network Setup Ranges

### 802.15.4 RF Network Setup

The MSI-4260M uses three numbers to connect to an 802.15.4 piconet:

For printer and serial output setup, see the following information:

To enter the menu:

1. Press **TARE** and **USER** at the same time. *Prnt* displays (Figure 6-1 on page 25).



**Note** *busy* may flash momentarily before entering the Communications menu.

2. Press **USER**. *RF* displays.
3. Press **TARE**. *On OFF* displays.
4. Press **USER** to scroll through parameters.
5. Press **TARE** to enter parameter. The current value flashes.
6. With parameter displayed, press **TARE** to select. The currently selected parameter flashes.
7. Press **USER** to scroll through settings.
8. Press **TARE**. *Sc id* displays.
9. Press **TARE**. The current ID flashes.
10. Enter the ID using **USER** to scroll through numbers and **TARE** to set number.
11. When ID is set, press **TARE** again. *Chnl* displays.
12. Press **TARE**. The current channel flashes.
13. Enter the channel using **USER** to scroll through numbers and **TARE** to set number.
14. When channel is set, press **TARE** again. *Net id* displays.
15. Enter the network ID using **USER** to scroll through numbers and **TARE** to set number.
16. When the ID is set, press **TARE** again. *On OFF* displays.
17. Press **ZERO** twice to save and exit to weighing mode.

## 7.0 Troubleshooting and Maintenance

### 7.1 Troubleshooting Guide

Problem	Possible Cause	Solution
Display is blank when the POWER button is depressed	Discharged batteries	Replace batteries
	Defective battery	Replace batteries
	Corroded battery or battery contacts	Clean the battery contacts
	Defective switch or circuit board	Requires authorized service
Display does not function properly, the front panel button does not function normally or the scale will not turn off	Improperly updated software	Reinstall the software
	Faulty circuit board	Requires authorized service
	Loose connectors	Requires authorized service
Scale does not respond to weight changes	Out of calibration	Calibrate the unit
	Faulty load cell	Replace the load cell
	Load cell connector	Check the connector and wires
The display over ranges below 100% capacity	Tared weight is added to load to determine overload point	Return to gross weight mode
	Zero requires adjustment	Rezero the scale
	Too much weight has been zeroed	Rezero the scale
The display drifts	AZM (Auto0) is turned off	Turn AZM on
	Rapid temperature change, moving scale outdoors from indoors	Wait until the scale temperature has stabilized
The displayed weight shows a large error	Scale not zeroed before load is lifted	Zero the scale with no load attached
	lb/kg units causing confusion	Select the proper units
	Requires recalibration	Recalibrate the unit
Display reading is not stable	Excessive vibration in crane system	Increase filtering or increase 'd' in Cal
	Excessive side loading	Improve load train symmetry
	Load cell faulty	Check the load cell connections
Display toggles between <i>Error</i> and <i>Load</i>	Weight exceeds capacity	Reduce weight immediately
	Faulty load cell or wiring	Check load cell and load cell wiring
Display toggles between <i>Error</i> and <i>UnLd</i>	Weight in below the zero range	If the scale is in compression, remove the source
	Calibration faulty	Recalibrate
	Faulty load cell or wiring	Check the load cell connections
Display toggles between <i>Error</i> and <i>RDLo</i>	A/D is saturated negative	Check the load cell and load cell wiring
Display toggles between <i>Error</i> and <i>bUtkn</i>	A key is stuck or is being held down	Check switches for damage
		Ensure that a remote is not transmitting continuously
RF remote device does not work	Units are not paired	Contact Rice Lake Weighing Systems
Unit turns on then immediately turns off	Batteries are low	Replace batteries
Weight will not zero	The system not stable	The stable annunciator must turn on for Zero to function; Increase the filtering for more stability
		Increase the filtering for more stability
The weight will not Zero, Tare or Total	The system is not stable	Legal-for-Trade units have limited zero range; Reduce the weight or use Tare instead
		Wait for Stable annunciator to turn on, or if in a mechanically noisy crane, increase the filtering or increase the size of the scale increment 'd'; It is also possible to increase the motion window; Contact Rice Lake Weighing Systems if you have a problem getting the MSI-4260M to zero, tare, or total due to stability issues
Setpoint lights blink	Setpoint is enabled and the trigger point has been reached	Disable set points if they are not needed
Manual total does not work	A function key is not set to "Total"	Set up Func1 or Func2 for "Total"
	The weight must be stable	Increase filtering for more stability
Auto Total does not work	The weight must be stable	Wait for stability annunciator to turn on, or increase filtering
	Weight thresholds not reached	Capacity must exceed 1% for autototal to work; Capacity must drop below 0.5% of capacity for additional weightments to register

Table 7-1. Troubleshooting Guide

## 7.2 Service Counters



**Only a Rice Lake Weighing Systems technician can reset the service counters, as these are an important safety warning feature. A thorough load train inspection is necessary to ensure product safety.**

The MSI-4260M maintains two service counters for safety.

- The first counter counts the number of times the scale has been overloaded
- The second counter counts lifts above 25% of capacity

These counters serve to warn the user to inspect the load train after a number of overloads, also when there is a chance of fatigue failure. The power up routine is interrupted when the lift counter exceeds 16383 lifts or the overload counter exceeds 1023 overloads. If the screen displays *LFCnE* when unit is powered on:

1. Press **TARE** to display the 25% lift counter.
2. Press **TARE** again to see the overload lift counter.
3. Press **ZERO** to acknowledge the warning and return to standard scale operation.



**Note** *The power up warning message will not appear for another 16383 lifts (or 1023 overloads).*

### 7.2.1 Access the Service Counters

Use the following steps to access the service counters.

4. Program a user function key to be *EEE* ([Section 4.2.2 on page 11](#))
5. Press **USER** .
6. Press **TARE** . The display flashes.
  - *LFCnE* (Lift Counter) followed by the number of times the weight has exceeded 25% of capacity
  - *OLCnE* (Overload Counter) followed by the number of times the weight has exceeded capacity
  - *C-CAL* (C-Calibration) followed by the C-Cal value

The display returns to the **Weighing** mode.

To stop the scrolling and step through them slowly proceed to [Step 7](#).

7. Press **USER** immediately after **TARE** is pressed.
8. Press **USER** to scroll through counters.
9. Press **TARE** to enter the counter, the value displays.
10. Press **ZERO** to return to **Weighing** mode.



**Only a Rice Lake Weighing Systems technician can reset the service counters, as these are important safety warning features. Depending on the circumstances, a thorough load train inspection might be necessary to ensure user safety.**

**Reference Rice Lake Weighing Systems Crane Scale Safety and Periodic Maintenance manual (Pub. 243-08-94D) for proper loading techniques to improve the safety and longevity of your MSI-4260M crane scale. This publication is available at [www.ricelake.com](http://www.ricelake.com) and is included in the CD shipped with your crane scale.**



**Note** *After the service counters are viewed, automatic warnings stop, but the counters continue to monitor lifts.*

## 8.0 Specifications

### Accuracy

± (0.1% +1 d) of applied load

### Resolution

Max NTEP Approved Class III: 2,500 Divisions  
 Max NTEP Approved Class III L: 5,000 Divisions  
 Max Non NTEP Approved: 10,000 Divisions

### Capacity

5,000 x 1 lb / 2,500 x 0.5 kg

### Enclosure

IP66 cast aluminum

### Lifting Eye and Lower Link

Top lifting eye with lower link interface that will fit a shackle

### Design Overload

200% Safe / 500% Ultimate

### Functions

Power Turns unit on or off  
 Zero Zeros applied load up to 100% of capacity (limited range in NTEP configurations)  
 Tare Tares applied load and displays weight in Net mode  
 User Programmable as test, total, unit, peak hold, net/gross, view total and print

### Display

Five-digit, 1.75" (44.5 mm) LCD with programmable brightness control

### Displayable Units

Pounds (lb) or kilograms (kg) selectable

### Annunciators

COZ, Battery Level, Net, Total, lb/kg, Stability, Scale Channels, RF and Setpoint LEDs

### Power

Battery operated, six (6) D cell 1.5 V alkaline batteries; NiMH rechargeable and/or Lithium

### Operating Time

Up to 1000 hours of battery life with typical use, less with RF option; also depends on display backlight brightness

### Operating Temperature

Legal-for-Trade	14°F– 140°F (-10°C–60°C)
Operating	-20°F–122°F (-28°C–50°C)

### Auto-Off Mode

Powers off after the scale is not used for the set time (in minutes); 15, 30, 45, 60 or OFF selectable

### Auto Sleep Mode

Powers down during non-use after the set time (in minutes) and powers up with weight change or any key press; 5, 15, 30 or OFF selectable

### Service Counters

Counts number of lifts over percentage of capacity and lifts over capacity

### Calibration

Digital (procedure initiated by calibration switch)

### Filtering

OFF, LO, HI-1 or HI-2 selectable

### Radio Link

DSSS (Direct Sequence Spread Spectrum)  
 IEEE 802.15.4  
 FHSS at 2.4 GHz

### Radio Effective Range

Typically 500' (150 m) indoor, 1000' (300 m) outdoor with standard antennas

### Totalization

Standard: Press button or Automatic;  
 TOTAL weight up to 99999 x 1000 kg/lb

### Setpoints

Eight user programmable setpoints. Setpoints 1–3 are visible on the device and LED outputs. Setpoints 4–8 can only be used by connecting a compatible RF Rugged Remote Control or RF remote display.

### Construction

All features are housed in heavy duty, cast aluminum housing consisting of three sections:

- The front section of the scale houses the display, controls and all electronics
- The center section contains the load cell, lifting eye, hook and quick access to the batteries
- The rear section of the scale features quick access to the batteries

### Warranty

One-year limited warranty

### Certifications and Approvals



NTEP  
 CoC Number 19-122  
 Accuracy Class: III L;  $n_{max}$ : 5000





© Rice Lake Weighing Systems Specifications subject to change without notice.  
Rice Lake Weighing Systems is an ISO 9001 registered company.

230 W. Coleman St. • Rice Lake, WI 54868 • USA

U.S. 800-472-6703 • Canada/Mexico 800-321-6703 • International 715-234-9171 • Europe +31 (0)26 472 1319